



Profile Performance Series™

# Reverse Osmosis Filtration System

### *Safety Information*

Proper Installation and Maintenance .....	2
Safety Precautions .....	2

### *Operating Instructions*

About the Reverse Osmosis System .....	4, 5
Faucet and Indicator Lights .....	5
Purging the System .....	5
Specification Guidelines .....	3

### *Care and Cleaning*

Battery Replacement .....	10
Check the System .....	8
Filter Replacement Procedures .....	6-8
Flow Control and Screen .....	9
RO Cartridge Replacement .....	9
Sanitizing the System .....	7, 10

### *Troubleshooting Tips*

Before You Call For Service .....	12, 13
Common Problems .....	14

### *Consumer Support*

Consumer Support ...	Back Cover
Warranty .....	15

### **Owner's Manual**

- PNRV18ZBB01
- PNRV18ZBL01
- PNRV18ZCC01
- PNRV18ZWH01
- PNRV18ZWW01



The GE RO PNRV18Z Model Series is Tested and Certified by NSF International against ANSI/NSF Standard 58 for TDS and Cyst reduction.

**Model number:** \_\_\_\_\_

**Serial number:** \_\_\_\_\_

You can find them on the side of the tank.



# IMPORTANT SAFETY INFORMATION. READ ALL INSTRUCTIONS BEFORE USING.

**⚠ WARNING!** For your safety, the information in this manual must be followed to minimize the risk of property damage or personal injury.



## SAFETY PRECAUTIONS

■ Check with your state and local public works department for plumbing and sanitation codes. You must follow these guidelines as you install the Reverse Osmosis system. **Using a qualified installer is recommended.**

■ If house water pressure is over the maximum (125 pounds per square inch), install a pressure reducing valve in the water supply line to the Reverse Osmosis system.

■ Be sure the water supply conforms with the *Specification guidelines*. If the water supply conditions are unknown, contact your municipal water company or your local health department for a list of contaminants in your area and a list of laboratories certified by your state to analyze drinking water.

**⚠ WARNING:** Before using the Reverse Osmosis system for the first time, the system must be purged. The Reverse Osmosis cartridge contains a food grade preservative that must be purged from the system. The preservative will give product water an unpleasant taste and odor.

■ This product reduces fluoride in drinking water. Please consult your dentist if you have questions.

**⚠ WARNING:** Do not use with water that is microbiologically unsafe or of unknown quality without adequate disinfection before or after the system. Systems certified for cyst reduction may be used on disinfected water that may contain filterable cysts. This system shall only be used for arsenic reduction on chlorinated water supplies containing detectable residual free chlorine at the system inlet. Water systems using an in-line chlorinator should provide a one minute chlorine contact time before the RO system. This Reverse Osmosis unit contains a replaceable membrane cartridge treatment component critical for effective reduction of Total Dissolved Solids. The water should be tested periodically to verify that the system is performing satisfactorily. This system is acceptable for treatment of influent concentrations of no more than 27 mg/L nitrate and 3 mg/L nitrite in combination measured as N and is certified for nitrate/nitrite reduction only for water supplies with a pressure of 280kPa (40 psig) or greater.



## PROPER INSTALLATION AND MAINTENANCE

This Reverse Osmosis system must be properly installed and located in accordance with the Installation Instructions before it is used. If you did not receive Installation Instructions, you can receive one by calling us toll-free at the GE Answer Center<sup>®</sup>, 800.626.2000.

■ Install or store where it will not be exposed to temperatures below freezing or exposed to any type of weather. Water freezing in the system will break it. Do not attempt to treat water over 100°F.

■ Do not install on **HOT WATER**. The temperature of the water supply to the Reverse Osmosis system must be between the minimum of 40°F and the maximum of 100°F. See the *Specification guidelines*.

■ **Do Not** open the water supply valve until the pipes have been flushed.

■ **Extended non-use of the Reverse Osmosis system**  
If the system is not used for one week or more, open the RO water faucet, allow the system to drain. Close the RO water faucet and allow the system to regenerate the water supply.

**⚠ WARNING:** Discard all unused parts and packaging material after installation. Small parts remaining after the installation could be a choke hazard.

■ Sanitize upon installation of the Reverse Osmosis system and after servicing inner parts, including replacement of prefilter, postfilter and Reverse Osmosis cartridge. It is important to have clean hands while handling inner parts of the system. See the *Sanitizing the Reverse Osmosis System* section.



READ AND FOLLOW THIS SAFETY INFORMATION CAREFULLY.  
**SAVE THESE INSTRUCTIONS**

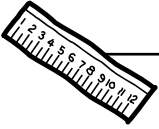

**Product – height 21" width 8" depth 10"**

The system makes a good supply of drinking water each day. How much it will make depends primarily on these things...

- 1 Feed water pressure—pounds per square inch (psi)**  
40–125
- 2 Feed water temperature limits—minimum/maximum degrees F.**  
40–100

**3 Water quality**

**Maximum Total Dissolved Solids (TDS)—parts per million (ppm)**  
2000

**Maximum water hardness @ 6.9 pH—grains per gallon (gpg)**  
10

*For water with hardness greater than 10 grains (at 6.9 pH) the use of a softener is recommended. Failure to install a water softener will reduce the life of the Reverse Osmosis membrane. See chart for additional information on the possible need for a water softener.*

**Maximum iron, manganese, hydrogen sulfide (ppm)**  
<0.1

**Chlorine in water supply**  
Allowable\*

**Feed water pH limits (pH)**  
4–10

**Percent rejection of TDS, minimum (new membrane)\*\***  
92

*\*Chlorine removed (maximum of 2.0 ppm) by the Reverse Osmosis prefilter...regular changing of the prefilter is required. Chlorine will destroy the Reverse Osmosis membrane.*

*\*\*Feed water at 50 psig and 77°F. with 750 ppm sodium chloride. Quality water production, amount of waste water and percent rejection all vary with changes in pressure, temperature and Total Dissolved Solids.*

*On average you should expect your Reverse Osmosis system to be able to deliver 18 gallons of product per day, as tested by Water Quality Association Standard S-300. Output according to ANSI/NSF Standard 58 is 10.9 gallons per day. Process water used per gallon of water produced is four gallons.*

**Water Softener Chart**

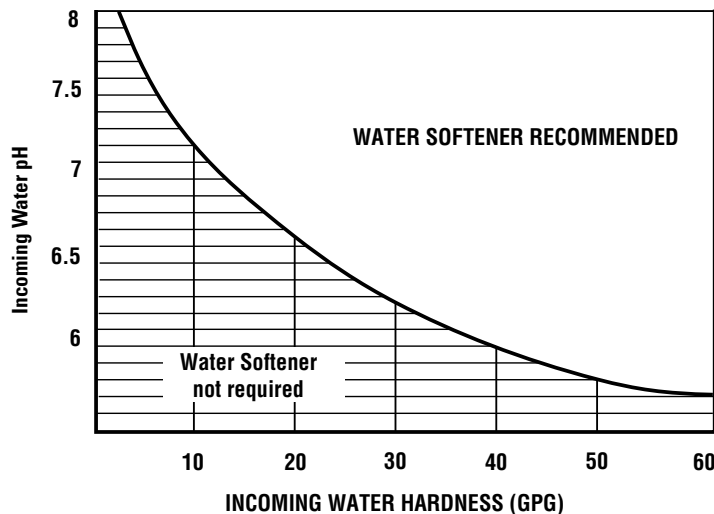

## About the reverse osmosis system.

### What the Reverse Osmosis System Does

Reverse Osmosis removes Total Dissolved Solids (TDS) and organic matter from water by diffusing it through a special membrane. The membrane separates minerals and impurities from the water and they are flushed to the drain. High quality product water goes directly to the drinking water faucet or to the storage tank. The system makes a good supply of drinking water each day (see *Specification guidelines*). How much it makes depends on the feed water supply pressure, temperature and quality.

The system includes an electronic faucet assembly with an integrated water testing feature. When water is taken from the faucet, a green indicator light means removal is within the specified limits and water quality is good.

Prefilters and postfilters are replaceable cartridges. The carbon prefilter removes chlorine while also filtering sediments. The postfilter removes any other undesirable tastes and odors before you use the water.

### How the Reverse Osmosis System Works

- 1 Prefilter**—Water from the cold supply pipe enters the Reverse Osmosis assembly and is directed to the prefilter cartridge.

**NOTE:** Before going to the prefilter, supply water first passes through the electronics box to measure TDS.

The prefilter is a replaceable sediment cartridge with activated carbon in its composition. The cartridge removes sand, silt, dirt, other sediments and up to 2.0 ppm of chlorine from the feed water. The prefilter reduces chlorine in the feed water because **CHLORINE DESTROYS THE REVERSE OSMOSIS MEMBRANE**. Filtered, clean, chlorine-reduced water flows from the prefilter to the Reverse Osmosis membrane cartridge.

- 2 Product Water Storage**—The storage area holds up to 1.9 gallons of product water. The flexible bladder keeps water pressurized for fast flow to the faucet when drinking water is needed.

- 3 Check Valve**—A check valve is built into the bottom end of the Reverse Osmosis housing. The check valve prevents a backward flow of product water from the storage area. A backward flow could cause rupture of the Reverse Osmosis membrane.

- 4 Automatic Shutoff Assembly**—To conserve water, the drinking water system has an automatic shutoff. When the storage tank has filled to capacity and the RO water faucet is closed, pressure closes the shutoff. Water flow to the Reverse Osmosis housing is shutoff until Reverse Osmosis water is used again, and pressure drops in the Reverse Osmosis system.

- 5 Reverse Osmosis Cartridge**—The cartridge, inside the Reverse Osmosis housing, includes a tightly wound, special membrane. Water is forced through the cartridge where the membrane removes the dissolved solids and organic matter. High quality product water exits the Reverse Osmosis housing and goes to the storage area. Reject water, with the dissolved solids and organic matter, leaves the housing and is discharged to the drain.

- 6 Postfilter**—After leaving the storage area, but before going to the faucet, product water goes to the postfilter. The postfilter is also the activated carbon type sediment filter. Any remaining tastes, odors, or sediments are removed from product water. Clean, high quality drinking water flows through the tubing and to the faucet.

- 7 Flow Control**—The flow control regulates flow of water through the Reverse Osmosis cartridge at the required rate to produce high quality water. The control is located in the drain tubing, at the Reverse Osmosis cap fitting. A small, cone-shaped screen fits over the front end of the flow control to help prevent plugging with drain water sediments.

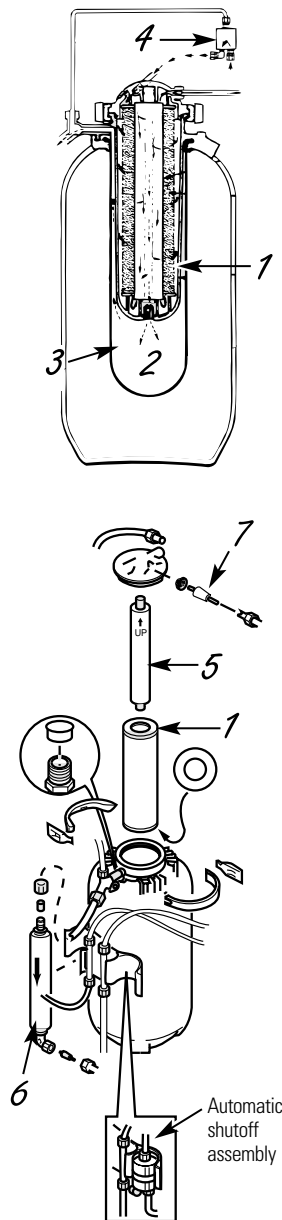

Further description of this illustration is in the Care and Cleaning section.

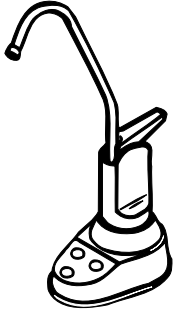

### The Faucet and Indicator Lights

**Faucet and Electronics**—The countertop faucet dispenses filtered drinking water when opened. It has a hand-operated, spring-loaded lever to prevent waste. You can keep the faucet open by pushing upward on the lever, until it locks against the faucet spout.

To comply with plumbing codes, an air gap is built into the faucet drain water connection.

The electronic faucet provides an integrated TDS monitor. As water is taken from the faucet, the indicator lights show how the Reverse Osmosis system is operating to provide high quality drinking water.

**Flashing Green Light**—The Reverse Osmosis system is providing high quality drinking water.

**NOTE:** If the Reverse Osmosis system is connected to the refrigerator, this light will also flash when the icemaker or water dispenser is in use. The green light may stop flashing when the supply of Reverse Osmosis water is nearly gone and flow from the RO faucet decreases. This is a normal condition.

**Flashing Amber "FILTER" Light**—The prefilter and postfilter cartridges need replacing. See the *Care and Cleaning* section.

**Flashing Amber "RO" Light**—The Reverse Osmosis cartridge is no longer removing at least 75% of the TDS from the supply water and needs replacing. See the *Care and Cleaning* section for Reverse Osmosis cartridge replacement. **NOTE:** Disregard initial or short periods (a few seconds) of the flashing "RO" light. Long periods of limited or non use can cause the TDS levels to temporarily change.

### If the Reverse Osmosis Filtration System Is Connected to Your Icemaker

Before you service the filter, change the filters, or purge the Filtration system, YOU MUST turn off the icemaker by raising the feeler arm. Four hours after servicing your unit, lower the feeler arm to resume icemaking.

### Purging the Reverse Osmosis System

Required upon initial installation or after the Reverse Osmosis cartridge is replaced.

**CAUTION:** The Reverse Osmosis cartridge contains a food grade preservative that should be purged from the system before first use or whenever the Reverse Osmosis cartridge is replaced. The preservative will give product water an unpleasant taste and odor.

- 1** Make sure all tubing connections are tightened.
- 2** Make sure the red tank shutoff valve is open. Turn on the water supply valve to the Reverse Osmosis system.
- 3** In about four hours, pressure will start to build in the Reverse Osmosis system. At that time, carefully check all fittings and tubing connections for any water leaks. Correct leaks if any are found.
- 4** Open the RO water faucet to drain the storage tank.
- 5** Close the RO water faucet after draining. Wait four hours until system has refilled. Then open the RO faucet to drain the storage tank.
- 6** Repeat the purging process for a total of four times.
- 7** The system is ready to make product water for your use.

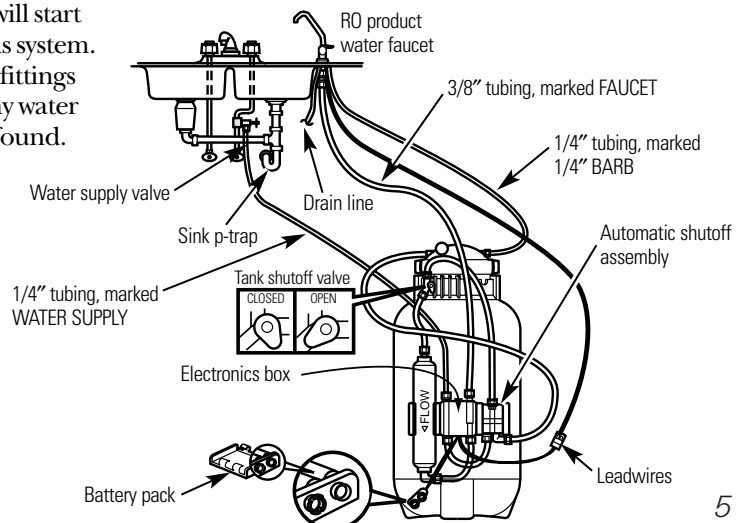

## Care and cleaning—Filter replacement procedures.

To obtain replacement filters, call GE Appliance Parts at 800-626-2002.

<b>Pre/Post Filter Cartridge Replacements FX18P</b>	<b>Activated Carbon</b>
<b>Reverse Osmosis Cartridge Replacement FX18M</b>	<b>Thin Film Polyamide</b>

You must replace the prefilter cartridge at least every six months to protect the Reverse Osmosis membrane from being destroyed by chlorine and/or from plugging with sediments in the water supply valve.

It is time to replace the Reverse Osmosis cartridge when the amber "RO" light, on the faucet base, flashes continually while Reverse Osmosis water is taken from the faucet.

To signal correct replacement interval for prefilter, postfilter and batteries, the amber "FILTER" indicator light, on the electronic faucet base, will begin to flash after six months, or 900 gallons of product water use, whichever occurs first.

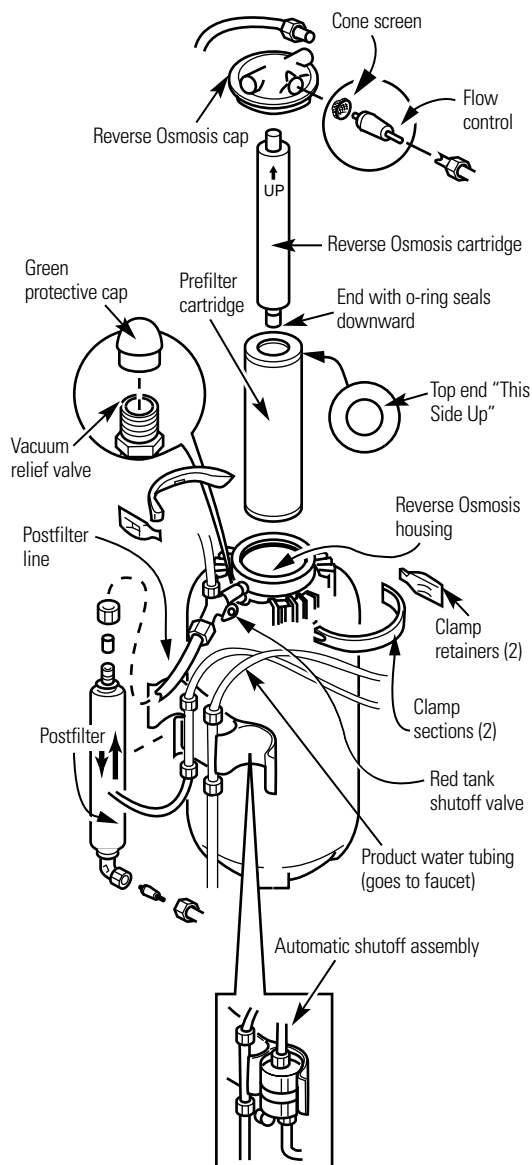

### Remove the Filters

**Be sure you have cleaned your hands with anti-bacterial soap before handling inner parts of the system.**

- Turn water supply valve to the Reverse Osmosis system off; turn clockwise. Turn RO faucet on and allow tank to completely drain (this will take a few minutes).

**NOTE:** If the Reverse Osmosis Filtration System is connected to your icemaker, YOU MUST turn off the icemaker by raising the feeler arm before servicing the filter, changing the filters or purging the filtration system. After completing work, allow four hours for unit to refill, then lower the feeler arm to resume icemaking.

- Pull the Reverse Osmosis system away from cabinet; leave tubing connected. Place a dry towel under the system.
- Remove the clamp retainers and sections from top of unit.
- Lift the Reverse Osmosis cap straight up (slight resistance is normal) from the Reverse Osmosis housing (no need to disconnect tubing) and move aside.

**NOTE:** If the cap o-ring remained in the Reverse Osmosis housing, replace it on the cap.

- Remove the Reverse Osmosis cartridge and the outer prefilter cartridge from the Reverse Osmosis housing and place the Reverse Osmosis cartridge in a clean plastic bag. Discard the prefilter cartridge. Dispose of water from the Reverse Osmosis housing.

- Turn off tank shutoff valve (red color).

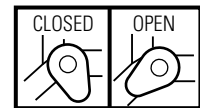

- Disconnect tubing at both ends of postfilter. Remove postfilter from holder and discard. Disconnect postfilter tube at tank shutoff valve. Retain postfilter tube.
- Hold a container under tank shutoff valve. Open shutoff valve and drain water from tank. (Expect up to 1/2 gallon.)
- Sanitize the system. Go to **Sanitizing the RO System** section and follow steps 1–8.

## Sanitize the System

**⚠ CAUTION:** Before sanitizing, be sure to remove all cartridges as described above. Chlorine will destroy the Reverse Osmosis cartridge.

- 1** Fill the Reverse Osmosis housing with fresh cold water, to about 1" from the top. Add one ounce (two tablespoons) of ordinary 5.25% household chlorine bleach (Hilex, Clorox, etc.) and mix into the water. Do not add chlorine first. Concentrated chlorine may damage plastics.
- 2** Replace the Reverse Osmosis cap with o-ring and install the clamp retainers.
- 3** Disconnect 3/8" product water tubing to faucet at electronics box. Connect the tubing to tank shutoff valve. See figure below.

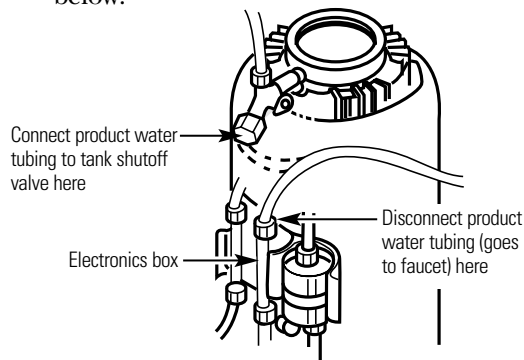

- 4** Open the water supply valve to the Reverse Osmosis system. Allow system to fill for one minute. Open the RO water faucet, locking the lever upward against the spout.
- 5** Allow water to flow through the Reverse Osmosis system until all bleach odor is gone (approximately 20 minutes).
- 6** Turn off the water supply valve to the Reverse Osmosis system. Close the RO water faucet **AFTER** water flow stops.
- 7** Disconnect 3/8" tubing from tank shutoff valve, and reconnect to electronics box. A small amount of water will drain when fitting is disconnected.
- 8** Remove the clamp retainers and sections from top of the unit. Lift the Reverse Osmosis cap straight up (slight resistance is normal) from the Reverse Osmosis housing (no need to disconnect tubing) and move aside. Dispose of water from the Reverse Osmosis housing.

**NOTE:** If the cap o-ring remained in the Reverse Osmosis housing, replace it on the cap.

## Replace the Filters

- 1** Place the prefilter cartridge in the Reverse Osmosis housing. Note "THIS SIDE UP" on one end. Then slide the Reverse Osmosis cartridge into the prefilter end with 2 o-rings first. Also note "UP" arrow printed side.

**NOTE:** Correct orientation is important. When assembled, the "THIS SIDE UP" should be visible on the end of the prefilter cartridge. The plastic end piece on the Reverse Osmosis cartridge should have no o-rings. See figure. Also, the top end of prefilter has a brine seal around the hole that seals to Reverse Osmosis cartridge. This seal must be pointed down, not visible, when the two parts are fully assembled.

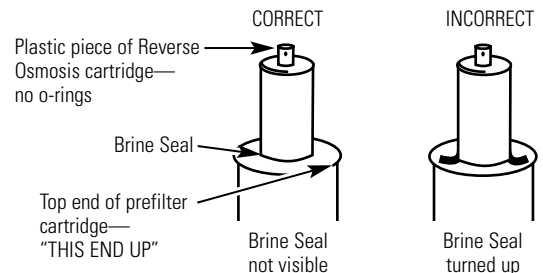

## Care and cleaning—Filter replacement procedures.

- 2 Lightly lubricate the cap o-ring with only clean silicone grease (included with replacement filters). Then, push the cap into position and install the clamp retainers and sections.
  - 3 Evacuate the residual water from tank. **This step is important to maintain optimal system performance.**
    - a. Assure tank shutoff valve is open.
    - b. Hold container under shutoff valve.
    - c. Locate vacuum relief valve under green cap.
    - d. Depress vacuum relief valve; water should drain from tank. Continue to depress valve until water flow approaches a drip. (Expect 1/2 to 1-1/2 gallons.)
    - e. Replace green protective cap on relief valve.
- ⚠ WARNING:** This valve stem is for vacuum relief only. Pressurizing the tank may cause it to rupture. Do not attempt to pressurize the tank.

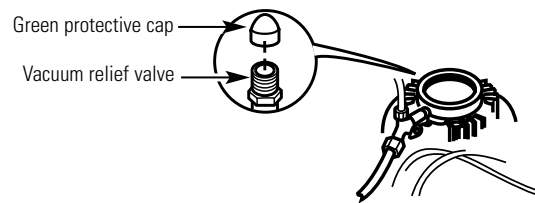

- 4 Assemble postfilter to unit. Remove protective caps from postfilter. Connect fittings of postfilter tube, removed at step 7 in the *Remove the Filters* section, to tank shutoff valve and top of postfilter. Connect fitting on tube from electronics box to bottom of postfilter. Snap postfilter into holder. The flow arrow printed on the side of the filter should be pointed down.
  - 5 Replace batteries in battery case with four new “AA” alkaline batteries. Note orientation “+” and “-” of batteries. Weak batteries will give no or a false indication. Replacing batteries also resets the six month clock and filter light will flash green.
- NOTE:** Lights may not operate properly until system has been allowed to refill tank. This takes approximately 4 hours.

### Check the System

- 1 Open the water supply valve and check for leaks.
 

**NOTE:** It will take approximately four hours to fully recharge your storage tank. You may notice ticking sounds at the faucet and the sound of water draining in your sink during this period. This is normal.
- 2 After the tank is full, before first use, open the RO faucet and completely drain tank to remove harmless carbon particles.
- 3 If your Reverse Osmosis is connected to your refrigerator icemaker, turn the icemaker on after the tank fills the second time. To turn the icemaker on, move the feeler arm to the down position.



## Reverse Osmosis Cartridge Replacement

**NOTE:** When replacing the Reverse Osmosis cartridge, also install a new flow control and screen.

It's time to replace the Reverse Osmosis cartridge when the amber "RO" light on the faucet base flashes continually while Reverse Osmosis water is taken from the faucet.

- 1 Follow steps 1 through 5 in the *Remove the Filters* section.
- 2 Place the prefilter cartridge back in the Reverse Osmosis housing. Note "THIS END UP" on one end. Then slide the new Reverse Osmosis cartridge into the prefilter end with 2 o-rings first. Also note "up" arrow on side. See *Replace the Filter* section, step 1 for diagram.

- 3 Remove and replace the flow control and screen. See the *Flow Control and Screen* section below.
- 4 Lightly lubricate the cap o-ring seal with only clean silicone grease. Then, push the cap into position and install the clamp sections and retainers.
- 5 Turn on the water supply valve and **PURGE THE REVERSE OSMOSIS CARTRIDGE.** See the *Purging the Reverse Osmosis System* section on page 5.

**CAUTION:** The Reverse Osmosis cartridge contains a food grade preservative that should be purged from the system before first use or whenever the Reverse Osmosis cartridge is replaced. The preservative will give product water an unpleasant taste and odor.

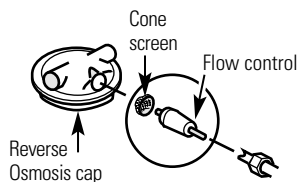

## Flow Control and Screen

The flow control regulates the flow of water through the Reverse Osmosis cartridge at the required rate so high quality product water is produced.

When servicing the Reverse Osmosis system, check the flow control and tubing to it, to make sure the tube and surrounding surfaces are clean and unrestricted. A small, cone-shaped screen is located in front of the flow control to help keep it clean. If the flow control or screen is plugged with foreign particles, the Reverse Osmosis cartridge cannot discharge minerals and impurities to the drain. If this happens, it will only take a short time for the cartridge to plug, making it useless.

- 1 Make sure the red tank shutoff valve is closed, water supply valve is closed (turn clockwise), and the RO water faucet is open to the system. Drain system until water stops flowing.
- 2 Locate the flow control and screen. Remove the straight tubing from the top of the Reverse Osmosis system.
- 3 Remove the flow control from the end of the tubing with a clean knife edge. Remove the screen; a toothpick may be needed for the interior portion of the cap.

- 4 If you are replacing the flow control and screen, discard them. If you are checking the flow control, screen and tubing for blockage, clean these parts of any debris. Do not blow through the flow control. It will contaminate the part.
- 5 Replace the screen by placing the cone end into the cap and carefully push it in.
- CAUTION:** Do not force in further after you feel resistance. Visually check to be sure it is properly positioned.
- 6 Install the flow control and tighten by hand, then another 1/4 turn with pliers. **DO NOT OVERTIGHTEN AND DISTORT OR CRUSH THE TUBING AND FLOW CONTROL.**

- 7 If you are replacing the Reverse Osmosis cartridge, return to the *Reverse Osmosis Cartridge Replacement* instructions. Otherwise, open red tank shutoff valve and water supply valve (turn counterclockwise). Close the RO water faucet.

## Care and cleaning of the reverse osmosis system.

---

### **Battery Replacement**

Always replace the four “AA” alkaline batteries in the control box when changing the prefilter and postfilter cartridges. Good batteries are needed to assure proper indicator light operation. Weak batteries may give a false indication. Changing the batteries also resets the six month or 900 gallon period.

---

### **Sanitizing the Reverse Osmosis System**

Sanitize upon installation of the Reverse Osmosis system and after servicing inner parts of the Reverse Osmosis system, including replacement of prefilter, postfilter and Reverse Osmosis cartridge. It is important to wash hands with anti-bacterial soap before handling inner parts of the system. See the *Sanitize the System* section for instructions.

**⚠ CAUTION:** *If installing unit in New Construction, ensure house plumbing is flushed thoroughly before opening the water supply valve. Also, before sanitizing, be sure to remove all cartridges as follows. Chlorine will destroy the Reverse Osmosis cartridge.*

**Safety Instructions**

**Operating Instructions**

**Care and Cleaning**

**Troubleshooting Tips**

**Consumer Support**

## Before you call for service...



*Troubleshooting Tips*  
Save time and money! Review the charts on the following pages first and you may not need to call for service.

<b>Problem</b>	<b>Possible Causes</b>	<b>What To Do</b>
<b>Sounds you might hear</b>	Running water from the unit to a drain.	<ul style="list-style-type: none"> <li>• This is normal.</li> </ul>
<b>Water has air bubbles and is cloudy</b>	Air in system after installation.	<ul style="list-style-type: none"> <li>• Will go away after it runs for a while.</li> </ul>
<b>Amber "FILTER" light on the faucet base is flashing</b>	Six months or 900 gallons of product water usage has occurred. This is the maximum life of the prefilter and postfilter.	<ul style="list-style-type: none"> <li>• Replace the prefilter, postfilter and batteries in the electronics box.</li> </ul>
<b>Amber "RO" light flashing. NOTE: Disregard initial or occasional short periods of this flashing light.</b>	Low usage of Reverse Osmosis product water.	<ul style="list-style-type: none"> <li>• Open the RO water faucet and allow system to drain. Close the RO water faucet and allow the system to regenerate the water supply.</li> </ul>
	The Reverse Osmosis membrane is no longer removing the required amount of Total Dissolved Solids.	<ul style="list-style-type: none"> <li>• Replace the Reverse Osmosis membrane cartridge, flow control and screen.</li> </ul>
	Water supply to the Reverse Osmosis system not within specifications.	<ul style="list-style-type: none"> <li>• Increase water pressure, precondition the water, etc., as needed to conform before doing maintenance on the Reverse Osmosis system.</li> </ul>
<b>Indicator lights on faucet base not working</b>	Incorrect brine seal after disassembly of inner parts.	<ul style="list-style-type: none"> <li>• See the <i>Replace the Filter</i> section, step 1 for correct brine seal.</li> </ul>
	Faucet base leadwire not connected to electronics box leadwire.	<ul style="list-style-type: none"> <li>• Connect.</li> </ul>
	Battery pack not connected to electronics box.	<ul style="list-style-type: none"> <li>• Connect.</li> </ul>
	Batteries installed incorrectly or expended.	<ul style="list-style-type: none"> <li>• Observe orientation markings on the holder and install correctly. Replace batteries if old.</li> </ul>
	Leadwires damaged.	<ul style="list-style-type: none"> <li>• Inspect and repair as needed.</li> </ul>

<b>Problem</b>	<b>Possible Causes</b>	<b>What To Do</b>
<b>Chlorine taste and/or odor in the Reverse Osmosis product water</b>	The ppm of chlorine in your water supply exceeds maximum limits and has destroyed the Reverse Osmosis membrane.	<ul style="list-style-type: none"> <li>• If the water supply contains more than 2.0 ppm of chlorine, additional filtering of the water supply to the Reverse Osmosis is needed. Correct this condition before doing maintenance on the Reverse Osmosis system.</li> </ul>
	The prefilter is no longer removing chlorine from the water supply.	<ul style="list-style-type: none"> <li>• Replace the Reverse Osmosis membrane cartridge, control, screen prefilter, postfilter and batteries in the electronics box.</li> </ul>
<b>Other taste and/or odor</b>	High quality product water may have a different taste than what you're used to.	<ul style="list-style-type: none"> <li>• This is normal.</li> </ul>
	Low water usage.	<ul style="list-style-type: none"> <li>• Completely drain system and allow to refill.</li> </ul>
	Contamination in product water storage.	<ul style="list-style-type: none"> <li>• Use sanitizing procedures.</li> </ul>
	Prefilter and postfilter need to be changed.	<ul style="list-style-type: none"> <li>• Replace the prefilter and postfilter.</li> </ul>
<b>Water leaking from faucet air gap hole</b>	Drain side of faucet air gap (3/8" tubing) plugged, restricted or incorrectly connected to the drain.	<ul style="list-style-type: none"> <li>• Inspect and eliminate restriction or plug. It is important that there are no dips, loops or low spots in the drain line from the faucet air gap to the drain pipe. Refer to Installation Instructions for proper drain connection. If drain line adapter was used as the drain point, periodic inspection/cleaning is recommended.</li> </ul>
<b>System makes product water slowly</b>	This is normal.	<ul style="list-style-type: none"> <li>• Water flow rate will be lower than your regular faucet.</li> </ul>
	Water supply to the Reverse Osmosis system not within specifications.	<ul style="list-style-type: none"> <li>• Increase water pressure, precondition the water, etc., as needed to conform before doing maintenance on the Reverse Osmosis system.</li> </ul>
	Prefilter cartridge plugged with sediments.	<ul style="list-style-type: none"> <li>• Replace the prefilter. If rate does not increase, replace the postfilter, Reverse Osmosis membrane cartridge, flow control, screen and batteries in the electronics box.</li> </ul>
	Reverse Osmosis membrane plugged with sediments.	
	Pressure in tank is low.	<ul style="list-style-type: none"> <li>– Turn off water supply valve.</li> <li>– Drain tank by opening RO faucet.</li> <li>– Disconnect post-filter cartridge connection at tank shut off valve.</li> <li>– Complete step 3 in the <i>Replace the Filters</i> section, page 8.</li> </ul>

# Common problems associated with filter or RO cartridge replacement.



## Troubleshooting Tips

Problem	Possible Causes	What To Do
<b>No Water</b>	Water supply valve not turned on.	• Turn water supply valve on. See diagram on page 5.
	Tank shutoff valve not turned on.	• Turn tank shutoff valve on. See diagram on page 6.
	After filter change, tank is empty.	• It takes 3–4 hours for RO system to provide enough water to fill the tank.
<b>Low flow from faucet</b>	Residual water not drained from tank.	• Turn on faucet and drain tank. Then complete procedure to evacuate residual water from tank. See step 3 under <i>Replace the Filters</i> .
<b>Leaks</b>	Leak at top cap.	• Remove RO cap and check black o-ring. <b>Pinched</b> —look for crimp on surface. Reassemble o-ring on cap first, then assemble cap to tank. Apply small amount of clean silicone grease. <b>Missing</b> —it probably fell into interior of tank. Remove prefilter and reverse osmosis cartridges and check for o-ring in housing. Reassemble o-ring to bottom of cap. Reassemble prefilter and reverse osmosis cartridges.
	Leak at fittings.	• Use pliers to tighten fittings until leak stops. Do not overtighten.
<b>FILTER light flashes yellow</b>	Batteries not changed.	• Replace batteries. See step 5 under <i>Replace the Filters</i> . When batteries are replaced the light will flash green and the 6 months timer will be reset.
<b>RO light flashes yellow</b>	Prefilter cartridge assembled upside down.	• Remove RO cap and look at end of prefilter cartridge. You should see “THIS SIDE UP” printed on end cap. If not, remove prefilter and reverse osmosis cartridges and reassemble. See step 1 under <i>Replace the Filters</i> .
	Incorrect orientation of brine seal between prefilter and reverse osmosis cartridges.	• Remove RO cap and look at point where prefilter rubber end cap seals to reverse osmosis cartridge. There is a lip seal at this point. It should NOT be visible. If you can see it pointing up along side the reverse osmosis cartridge, remove prefilter and reverse osmosis cartridges and reassemble. See step 1 under <i>Replace the Filters</i> .
<b>No lights</b>	Batteries assembled incorrectly.	• Remove batteries and reassemble according to diagram on battery case.
	Batteries are dead.	• Use 4 new AA batteries.

# GE Reverse Osmosis System Warranty.



All warranty service provided by our Factory Service Centers, or an authorized Customer Care<sup>®</sup> technician. To schedule service, on-line, 24 hours a day, contact us at [www.GEAppliances.com](http://www.GEAppliances.com), or call 800-GE-CARES.

Staple your receipt here.  
Proof of the original purchase date is needed to obtain service under the warranty.

## For The Period Of: **GE Will Replace:**

**One Year**  
From the date of the original purchase

**Any part** of the Reverse Osmosis Filtration System which fails due to a defect in materials or workmanship. During this **full one-year warranty**, GE will also provide, **free of charge**, all labor and in-home service to replace the defective part.

## What GE Will Not Cover:

- Service trips to your home to teach you how to use the product.
- Improper installation.
- Failure of the product if it is abused, misused, or used for other than the intended purpose or used commercially.
- Filters, membranes or batteries.
- Replacement of house fuses or resetting of circuit breakers.
- Damage to the product caused by accident, fire, floods or acts of God.
- Incidental or consequential damage caused by possible defects with this appliance.

*This warranty is extended to the original purchaser and any succeeding owner for products purchased for home use within the USA. In Alaska, the warranty excludes the cost of shipping or service calls to your home.*

*Some states do not allow the exclusion or limitation of incidental or consequential damages. This warranty gives you specific legal rights, and you may also have other rights which vary from state to state. To know what your legal rights are, consult your local or state consumer affairs office or your state's Attorney General.*

**Warrantor: General Electric Company. Louisville, KY 40225**

Safety Instructions

Operating Instructions

Care and Cleaning

Troubleshooting Tips

Consumer Support

## Consumer Support.

---



### *GE Appliances Website*

[www.GEAppliances.com](http://www.GEAppliances.com)

Have a question or need assistance with your appliance? Try the GE Appliances Website 24 hours a day, any day of the year! For greater convenience and faster service, you can now download Owner's Manuals, order parts, catalogs, or even schedule service on-line. You can also "Ask Our Team of Experts™" your questions, and so much more...



### *Schedule Service*

[www.GEAppliances.com](http://www.GEAppliances.com)

Expert GE repair service is only one step away from your door. Get on-line and schedule your service at your convenience 24 hours any day of the year! Or call 800-GE-CARES (800-432-2737) during normal business hours.



### *Real Life Design Studio*

[www.GEAppliances.com](http://www.GEAppliances.com)

GE supports the Universal Design concept—products, services and environments that can be used by people of all ages, sizes and capabilities. We recognize the need to design for a wide range of physical and mental abilities and impairments. For details of GE's Universal Design applications, including kitchen design ideas for people with disabilities, check out our Website today. For the hearing impaired, please call 800-TDD-GEAC (800-833-4322).



### *Extended Warranties*

[www.GEAppliances.com](http://www.GEAppliances.com)

Purchase a GE extended warranty and learn about special discounts that are available while your warranty is still in effect. You can purchase it on-line anytime, or call 800-626-2224 during normal business hours. GE Consumer Home Services will still be there after your warranty expires.

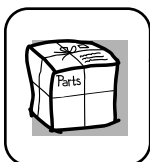

### *Parts and Accessories*

[www.GEAppliances.com](http://www.GEAppliances.com)

Individuals qualified to service their own appliances can have parts or accessories sent directly to their homes (VISA, MasterCard and Discover cards are accepted). Order on-line today, 24 hours every day or by phone at 800-626-2002 during normal business hours.

**Instructions contained in this manual cover procedures to be performed by any user. Other servicing generally should be referred to qualified service personnel. Caution must be exercised, since improper servicing may cause unsafe operation.**

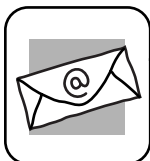

### *Contact Us*

[www.GEAppliances.com](http://www.GEAppliances.com)

If you are not satisfied with the service you receive from GE, contact us on our Website with all the details including your phone number, or write to: General Manager, Customer Relations  
GE Appliances, Appliance Park  
Louisville, KY 40225



### *Register Your Appliance*

[www.GEAppliances.com](http://www.GEAppliances.com)

**Register your new appliance on-line—at your convenience!** Timely product registration will allow for enhanced communication and prompt service under the terms of your warranty, should the need arise. You may also mail in the pre-printed registration card included in the packing material, or detach and use the form in this Owner's Manual.



## Free Manuals Download Website

<http://myh66.com>

<http://usermanuals.us>

<http://www.somanuals.com>

<http://www.4manuals.cc>

<http://www.manual-lib.com>

<http://www.404manual.com>

<http://www.luxmanual.com>

<http://aubethermostatmanual.com>

Golf course search by state

<http://golfingnear.com>

Email search by domain

<http://emailbydomain.com>

Auto manuals search

<http://auto.somanuals.com>

TV manuals search

<http://tv.somanuals.com>