

8000 Series

Operating Manual
Genelec 8040A and 8050A
Monitoring Systems

GENELEC®





Genelec 8040A and 8050A Monitoring Systems

System

The GENELEC 8040A and 8050A are two way active monitoring loudspeakers designed to produce high SPL output, low coloration and broad bandwidth in a small enclosure size. They are suitable for a wide variety of tasks, such as near field monitoring, mobile vans, broadcast and TV control rooms, surround sound systems and home studios. Designed as active loudspeakers, they contain drivers, power amplifiers, active crossover filters and protection circuitry. The Minimum Diffraction Enclosure™ (MDE™) and advanced Directivity Control Waveguide™ (DCW™) technologies provide excellent frequency balance even in difficult acoustic environments.

Drivers

The bass driver dimensions are 165 mm (6 1/2") and 205 mm (8") for 8040A and 8050A respectively. The long, flow optimized reflex tube has a large cross sectional area and terminates with a wide flare at the back of the enclosure. The high frequency driver is a 19 mm (3/4") metal dome on the 8040A and a 25 mm (1") metal dome on the 8050A. Both drivers are magnetically shielded.

Crossover

The active crossover network consists of two parallel bandpass filters. The crossover frequency is 3.0 kHz on the 8040A and 1.8 kHz on the 8050A. The active crossover controls ("treble tilt", "desktop low frequency", "bass tilt" and "bass roll-off") allow precise matching of the loudspeakers to any room environment.

Amplifiers

The amplifier unit is mounted in the rear of the loudspeaker enclosure. The unit incorporates special circuitry for driver thermal overload protection. Variable input sensitivity allows accurate level matching to console output section.

Connections

Each loudspeaker is supplied with a mains cable and an operating manual. Before connecting up, ensure that the mains switch is off (see figure 1). Audio input is via a 10 kOhm balanced XLR connector, but unbalanced leads may be used as long as pin 3 is grounded to pin 1 of the XLR (see figure 3). Once the connections have been made, the loudspeakers are ready to be switched on.

Mounting considerations

Align the loudspeakers correctly

Always place the loudspeakers so that their acoustic axes (see figure 2) are aimed towards the listening position. Vertical placement is preferable, as it minimises acoustical cancellation problems around the crossover frequency.

Maintain symmetry

Check that the loudspeakers are placed symmetrically and at an equal distance from the listening position. If possible, place the system so that the listening position is on the centerline of the room and the loudspeakers are placed at an equal distance from the centerline.

Minimise reflections

Acoustic reflections from objects close to the loudspeakers like desks, cabinets, computer monitors etc. can cause unwanted coloration and blurring of the sound image. These can be minimised by placing the loudspeaker clear of reflective surfaces. For instance, putting the loudspeakers on stands behind and above the mixing console usually gives a better result than placing them on the meter bridge.

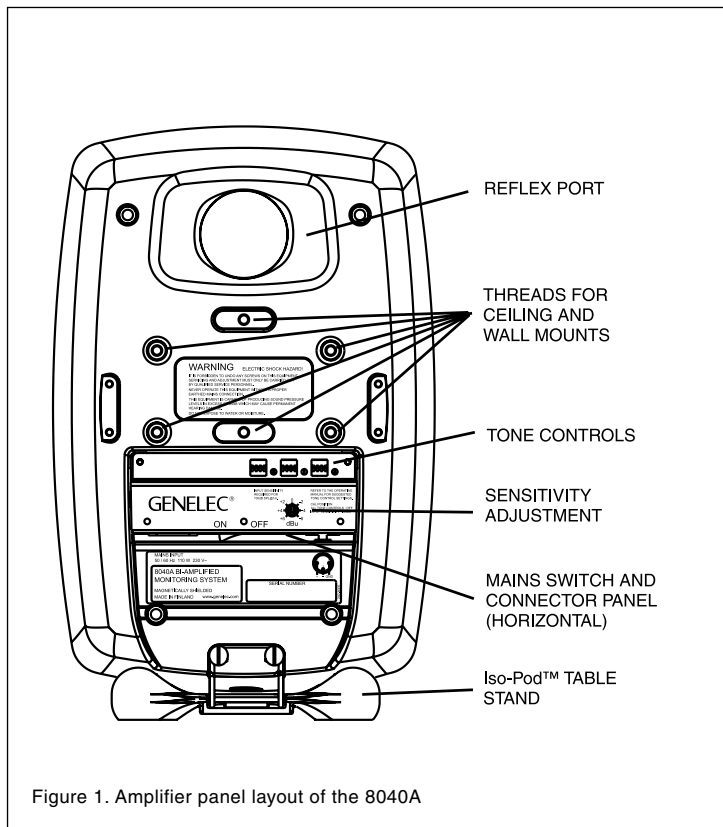

Figure 1. Amplifier panel layout of the 8040A

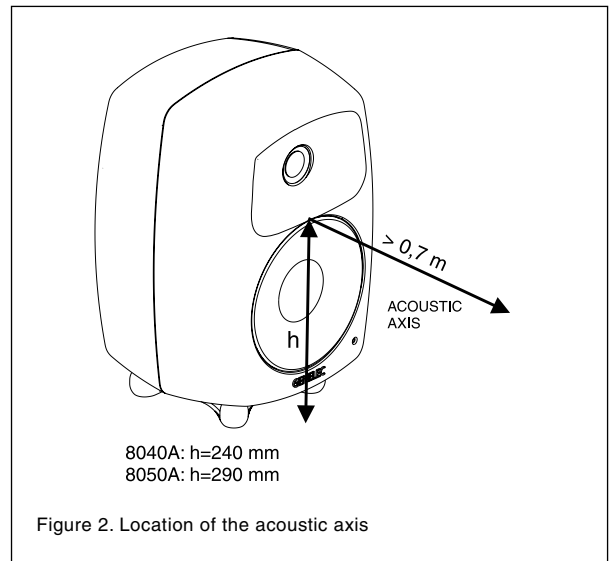

Figure 2. Location of the acoustic axis

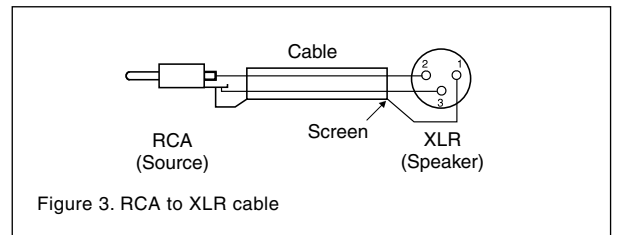

Figure 3. RCA to XLR cable

Minimum clearances

Sufficient cooling for the amplifier and functioning of the reflex port must be ensured if the loudspeaker is installed in a restricted space such as a cabinet, or integrated into a wall structure. The surroundings of the loudspeaker must always be open to the listening room with a minimum clearance of 5 centimeters (2") behind, above and on both sides of the loudspeaker. The space adjacent to the amplifier must either be ventilated or sufficiently large to dissipate heat so that the ambient temperature does not rise above 35 degrees Celsius (95°F).

Mounting options

The vibration insulating Isolation Positioner/Decoupler™ (Iso-Pod™) table stand allows tilting of the loudspeaker for correct alignment of the acoustic axis. The stand can be attached to three mounting points allowing vertical and symmetrical horizontal positioning (see figures 1 and 4).

Genelec 8040A and 8050A can be fitted to Omnimount® Series 30 (8040A) and 60 (8050A) and König & Meyer loudspeaker mounts on two sets of M6x10 mm threaded holes on the back of the enclosure. On the base of the enclosure is an M10x10 mm

threaded hole which can be used for securing the loudspeaker to its base. Do not use this thread for mounting the loudspeaker on a microphone stand which has a 3/8" UNC thread.

Setting the input sensitivity

The input sensitivity of the loudspeakers can be matched to the output of the mixing console, or other source, by adjusting the input sensitivity control on the rear panel (see figure 1). A screwdriver is needed for the adjustment. The manufacturer's default setting for this control is -6 dBu (fully clockwise) which gives an SPL of 100 dB @1m with -6 dBu input level.

Setting the tone controls

The frequency response of the system may also have to be adjusted to match the acoustic environment. The adjustment is carried out by setting the three tone control switch groups "treble tilt", "bass tilt" and "bass roll-off" on the rear panel of the amplifier. There is also a special "desktop low frequency" tone control which gives an attenuation of 4 dB at 160 Hz to compensate the effect of a mixing console, desk or other reflective surface between the listener

and the loudspeaker. The factory settings for these controls are all "OFF" to give a flat anechoic response.

Bass roll-off control

Bass roll-off (first switch group from the left) affects the low frequency roll-off of the loudspeaker and attenuates its energy output near the cut-off frequency. Attenuation levels of -2, -4 or -6 dB can be selected.

Desktop low frequency control

The desktop low frequency control (fourth switch of first switch group from the left) attenuates the bass frequencies around 160 Hz by 4 dB (see figures 8 and 10). This feature is designed to compensate for the boost often occurring at this frequency range when the loudspeaker is placed upon a meter bridge, table or similar reflective surface.

Bass tilt control

The bass tilt control switches (second switch group from the left) offer three attenuation levels for the bass response below 800 Hz, usually necessary when the loudspeakers are placed near room boundaries. The attenuation levels are -2 dB, -4 dB and -6 dB.

Speaker Mounting Position	Treble tilt	Bass tilt	Bass roll-off	Desktop LF
Flat anechoic response	None	None	None	None
Free standing in a damped room	None	-2 dB	None	None
Free standing in a reverberant room	None	-4 dB	None	None
Near field on a reflective surface	None	-2 dB	None	-4 dB
In a corner	None	-4 dB	-4 dB	None

Table 1. Suggested tone control settings in some typical situations

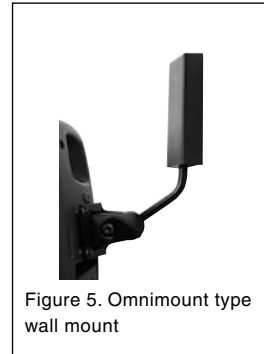

Figure 5. Omnimount type wall mount

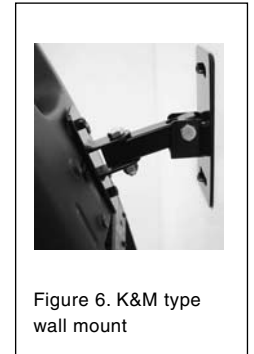

Figure 6. K&M type wall mount

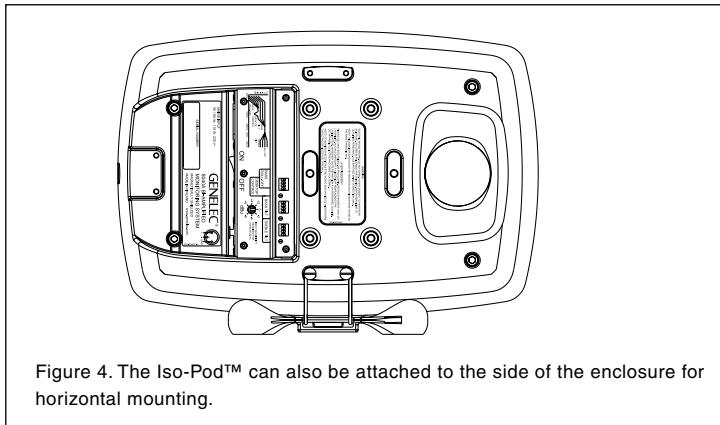

Figure 4. The Iso-Pod™ can also be attached to the side of the enclosure for horizontal mounting.



Figure 7. Carrying bag for a pair of 8040A loudspeakers.

Treble tilt control

Treble tilt (third switch group from the left) allows adjusting the treble response above 5 kHz by +2, -2, or -4 dB, which can be used for correcting an excessively bright or dull sounding system.

An acoustic measuring system such as MLSSA or WinMLS is recommended for analyzing the effects of the adjustments, however, careful listening with suitable test recordings can also lead to good results if a test system is not available. Table 1 shows some typical settings in various situations. Figures 8 and 10 show the effect of the controls on the anechoic response.

Always start adjustment by setting all switches to "OFF" position. Then set only one switch per group to the "ON" position to select the desired adjustment. If more than one switch is set to "ON" (within one switch group) the attenuation value is not accurate.

Measure or listen systematically through the different combinations of settings to find the best frequency balance.

Maintenance

No user serviceable parts are to be found within the loudspeaker cabinet or the ampli-

fier unit. Any maintenance or repair of the loudspeaker should only be undertaken by qualified service personnel.

Safety considerations

Although the 8040A and 8050A have been designed in accordance with international safety standards, to ensure safe operation and to maintain the loudspeaker under safe operating conditions, the following warnings and cautions must be observed:

1. Servicing and adjustment must only be performed by qualified service personnel. The loudspeaker must not be opened.
2. Do not use this product with an unearthed mains cable as this may lead to personal injury.
3. To prevent fire or electric shock, do not expose the unit to water or moisture. Do not place any objects filled with liquid, such as vases on the loudspeaker or near it.
4. Note that the amplifier is not completely disconnected from the AC mains service unless the mains power cord is removed from the amplifier or the mains outlet.

5. Free flow of air behind the loudspeaker is necessary to maintain sufficient cooling. Do not obstruct airflow around the loudspeakers.

WARNING!

Genelec 8040A and 8050A loudspeakers are capable of producing sound pressure levels in excess of 85 dB, which may cause permanent hearing damage.

8040A Accessories

	Order code
Floor stand black	8000-400
Wall mount black (Omnimount)	8040-404-B
Ceiling mount black (Omnimount)	8040-405-B
Wall mount black (K&M)	8000-401
Soft carrying bag for two monitors	8040-420

8050A Accessories

	Order code
Floor stand black	8000-400
Wall mount black (Omnimount)	8050-404-B
Ceiling mount black (Omnimount)	8050-405-B
Soft carrying bag for one monitor	8050-420

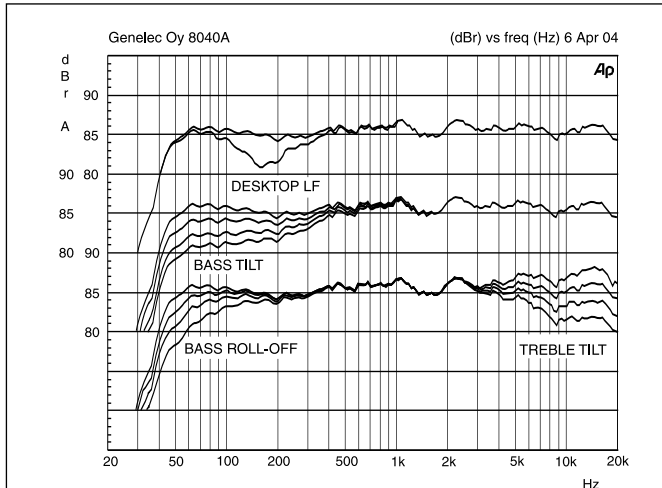

Figure 8. The curves above show the effect of the "bass tilt", "treble tilt", "desktop low frequency" and "bass roll-off" controls on the free field response of the 8040A.

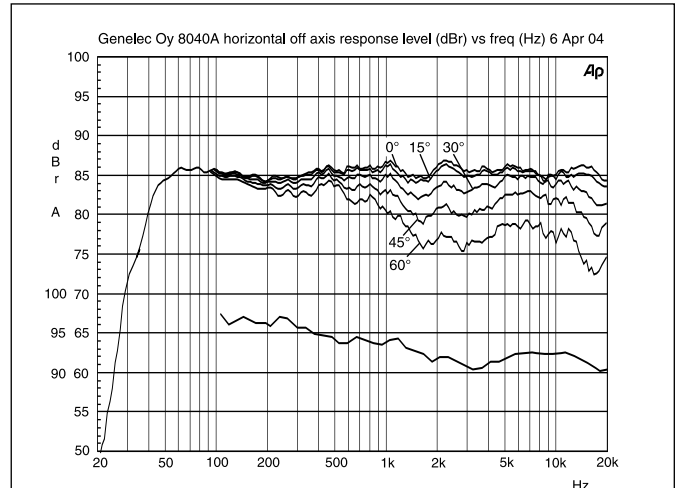

Figure 9. The upper curve group shows the horizontal directivity characteristics of the 8040A measured at 1 m. The lower curve shows the system's power response.

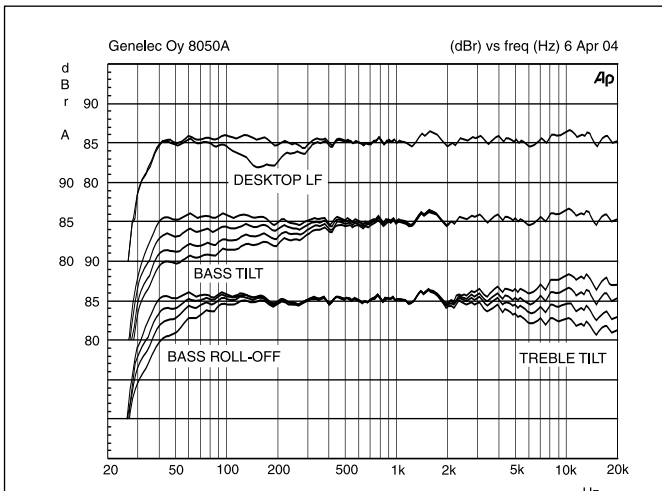

Figure 10. The curves above show the effect of the "bass tilt", "treble tilt", "desktop low frequency" and "bass roll-off" controls on the free field response of the 8050A

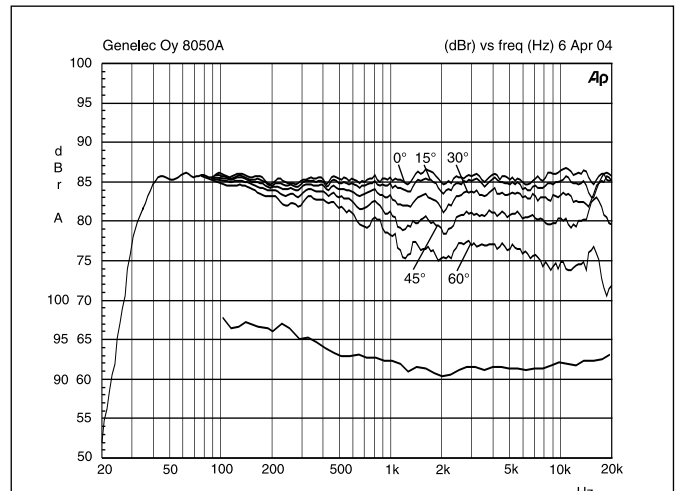

Figure 11. The upper curve group shows the horizontal directivity characteristics of the 8050A measured at 1 m. The lower curve shows the system's power response.

EC Declaration of Conformity

This is to certify that Genelec Monitoring Systems 8040A and 8050A conform to the following standards:

Safety:
EN 60065 / IEC 60065:1998 6th Edition

EMC:
EN 55013: (2001)
EN 55020: (1994), A11: (1996), A12: (1999), A13: (1999), A14: (1999)
EN 61000-3-2 (2000)
EN 61000-3-3 (1995)

The product herewith complies with the requirements of The Low Voltage Directive 73/23/EEC, EMC Directive 89/336/EEC and 93/68/EEC

Signed: *[Signature]*
Ilpo Martikainen
Position: Managing Director
Date: 20-April-2004

Guarantee

Genelec 8040A and 8050A are supplied with one year guarantee against manufacturing faults or defects that might alter the performance of the loudspeakers. Refer to supplier for full sales and guarantee terms.

8040A and 8050A Operating Manual

SYSTEM SPECIFICATIONS		
	8040A	8050A
Lower cut-off frequency, -3 dB	≤ 45 Hz	≤ 35 Hz
Upper cut-off frequency, -3 dB	≥ 21 kHz	≥ 21 kHz
Free field frequency response of system (± 2.0 dB)	48 Hz - 20 kHz	38 Hz - 20 kHz
Maximum short term sine wave acoustic output on axis in half space, averaged from 100 Hz to 3 kHz		
@ 1 m	≥ 105 dB SPL	≥ 110 dB SPL
@ 0.5 m	≥ 111 dB SPL	≥ 116 dB SPL
Maximum long term RMS acoustic output in same conditions with IEC weighted noise (limited by driver unit protection circuit) @ 1 m	≥ 99 dB SPL	≥ 101 dB SPL
Maximum peak acoustic output per pair above console top, @ 1 m from the engineer with music material	≥ 115 dB SPL	≥ 120 dB SPL
Self generated noise level in free field @ 1m on axis (A-weighted)	≤ 10 dB	≤ 10 dB
Harmonic distortion at 90 dB SPL @ 1m on axis		
Freq. 50 to 100 Hz	< 2 %	< 2 %
> 100 Hz	< 0.5 %	< 0.5 %
Drivers:		
Bass	165 mm (6 1/2")	205 mm (8")
Treble	19 mm (3/4")	25 mm (1")
Both drivers are magnetically shielded	metal dome	metal dome
Weight:	8.6 kg (18.9 lbs)	12.7 kg (28 lbs)
Dimensions:		
Height (without table support)	350 mm (13 13/16")	433 mm (17 1/16")
Height (including table support)	365 mm (14 3/8")	452 mm (17 13/16")
Width	237 mm (9 3/8")	286 mm (11 1/4")
Depth	223 mm (8 13/16")	278 mm (10 15/16")

CROSSOVER SECTION		
	8040A	8050A
Input connector XLR female	Pin 1 gnd, pin 2 +, pin 3 -	
Input impedance	10 kOhm balanced	
Input level for maximum short term output of 100 dB SPL @ 1m:	Adjustable from +6 to -6 dBu	
Crossover frequency, Bass/Treble	3.0 kHz	1.8 kHz
Treble tilt control operating range in 2 dB steps	From +2 to -4 dB & MUTE @ 15 kHz	From +2 to -4 dB & MUTE @ 15 kHz
Desktop low frequency control operating range	-4 dB @ 160 Hz	-4 dB @ 160 Hz
Bass roll-off control operating range in 2 dB steps	From 0 to -6 dB @ 45 Hz	From 0 to -6 dB @ 35 Hz
Bass tilt control operating range in 2 dB steps	From 0 to -6 dB @ 100 Hz & MUTE	From 0 to -6 dB @ 100 Hz & MUTE
	The 'CAL' position is with all tone controls set to 'off' and the input sensitivity control to maximum (fully clockwise)	

AMPLIFIER SECTION		
	8040A	8050A
Bass amplifier short term output power	90 W (8 Ohm load)	150 W (6 Ohm load)
Treble amplifier short term output power	90 W (8 Ohm load)	120 W (8 Ohm load)
Long term output power is limited by driver unit protection circuitry		
Amplifier system distortion at nominal output		
THD	≤ 0.05 %	≤ 0.05 %
SMPTE-IM	≤ 0.05 %	≤ 0.05 %
CCIF-IM	≤ 0.05 %	≤ 0.05 %
DIM 100	≤ 0.05 %	≤ 0.05 %
Signal to Noise ratio, referred to full output		
Bass	≥ 100 dB	≥ 100 dB
Treble	≥ 100 dB	≥ 100 dB
Mains voltage	100, 120, 220 or 230 V according to region	
Voltage operating range	±10 %	±10 %
Power consumption		
Idle	10 VA	10 VA
Full output	110 VA	170 VA

Genelec Document D0003R001a Copyright Genelec Oy 2.2005-. All data subject to change without prior notice

www.genelec.com

GENELEC®

International enquiries:
Genelec, Olvittie 5
FIN-74100, Iisalmi, Finland
Phone +358 17 83881
Fax +358 17 812 267
Email genelec@genelec.com

In the U.S. please contact:
Genelec, Inc., 7 Tech Circle
Natick, MA 01760, USA
Phone +1 508 652 0900
Fax +1 508 652 0909
Email genelec.usa@genelec.com

In China please contact:
Beijing Genelec Audio Co. Ltd.
Jianwai SOHO, Tower 12, Room 2306
39 East 3rd Ring Road
Chaoyang District, Beijing 100022, China
Phone +86 0 5869 7915
Fax +86 10 5869 7914

In Sweden please contact:
Genelec Sverige
Box 5521, S-141 05 Huddinge
Phone +46 8 449 5220
Fax +46 8 708 7071
Email info@genelec.com

Free Manuals Download Website

<http://myh66.com>

<http://usermanuals.us>

<http://www.somanuals.com>

<http://www.4manuals.cc>

<http://www.manual-lib.com>

<http://www.404manual.com>

<http://www.luxmanual.com>

<http://aubethermostatmanual.com>

Golf course search by state

<http://golfingnear.com>

Email search by domain

<http://emailbydomain.com>

Auto manuals search

<http://auto.somanuals.com>

TV manuals search

<http://tv.somanuals.com>