

GENELEC®

ACTIVE MONITORING

Genelec 1094A and 1092A Active Subwoofer Systems

Operating Manual



Genelec 1094A and 1092A Subwoofers

General Description

The Genelec 1094A and 1092A active subwoofers are powerful low frequency loudspeakers, incorporating all the amplifier and crossover electronics needed to combine them with other loudspeakers and amplifiers.

Drivers

The 1094A contains a single 385mm (15") long throw cone driver, housed in a 110 litre vented cabinet. A cavity over the driver boosts the drivers efficiency and acoustically attenuates possible distortion components. The 1092A utilises two 210mm (8") cone drivers, housed in a 55 litre vented cabinet, and employs driver front loading.

Crossovers

The 3+1 channel active crossover within the amplifier unit filters the low and high frequency components of the three front channels, dividing the input signals between the subwoofer and the main monitors. A separate subwoofer input connector allows for complete compatibility with digital 5.1 channel surround sound systems.

The crossover filter also provides calibrated 'Bass Roll-off' and 'Phase' controls, minimising the effects of the room on the performance of the subwoofer.

Amplifiers

The amplifier unit is mounted in the rear of the cabinet on quick release vibration isolators to ensure rattle free operation and long term reliability. The 1094A and 1092A amplifier output powers are 400W and 180W respectively. The amplifiers incorporate special driver protection circuitry for driver overload protection.

Installation

Each subwoofer is supplied with a mains cable and an operating manual. Once unpacked, place the subwoofer in a suitable position (for more details see the 'Positioning' section).

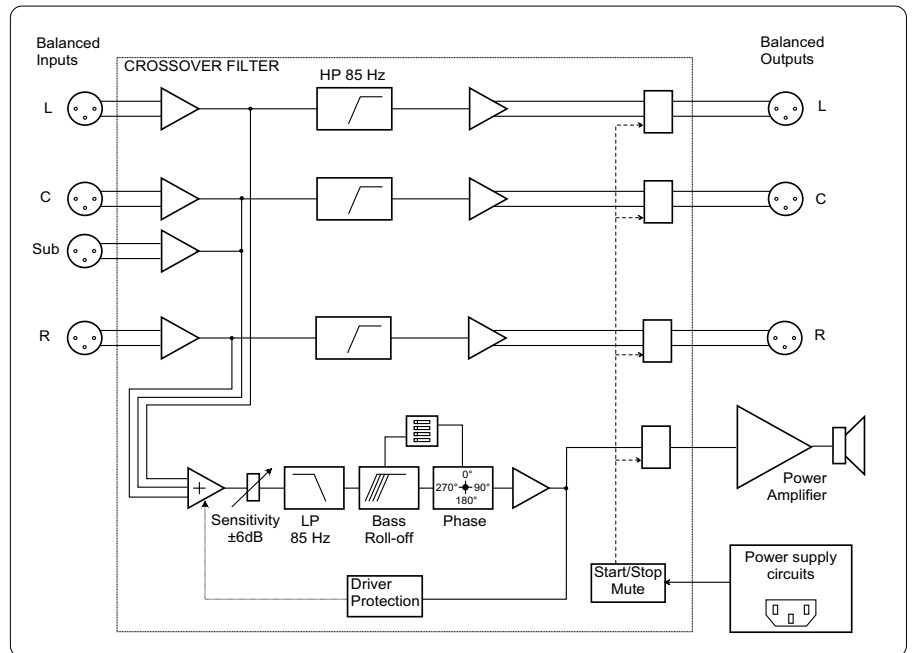

Figure 1. Functional blocks of Genelec 1094A and 1092A Subwoofers

Before connecting the audio signals, ensure that both the subwoofer and the main monitors are switched off. Check that the subwoofer voltage selector switch is set to the correct voltage and that the correct fuse for that voltage is fitted.

Audio connections to the subwoofer are made via balanced XLR connectors. Signals from the source are fed into the subwoofer input connectors and signals for the main monitors are taken from the subwoofer output connectors. Once all connections have been made, the subwoofer and main monitors are ready to be powered up.

Setting the Input Sensitivity

The subwoofer requires input sensitivity alignment to the mixing console or other source to obtain a correctly balanced system. The input

sensitivity control is located on the rear panel of the subwoofer. An input voltage of -6dBu with a -6dBu input sensitivity setting will produce 100dB SPL @ 1m. To obtain a 110dB SPL output an input voltage of +10dBu is required when the input sensitivity is set to 0dBu.

Setting the Bass Roll-Off Switches

The acoustic response of the subwoofer may have to be matched to the characteristics of room in which it will be used. To adjust the subwoofer to match these characteristics use the "Bass Roll-off" control switches located on the rear panel of the subwoofer. Table 1 provides some suggestions for the 'Bass Roll-off' switch settings. When both roll-off switches are 'off', a flat anechoic response results.

Room Type	Bass Roll-Off	
	Sw1 (-2dB)	Sw2 (-4dB)
Flat Anechoic Response	OFF	OFF
Positioned near a wall	ON	OFF
Positioned in a corner	ON	ON

Table 1. Suggested Bass Roll-Off switch settings.

Subwoofer Positioning

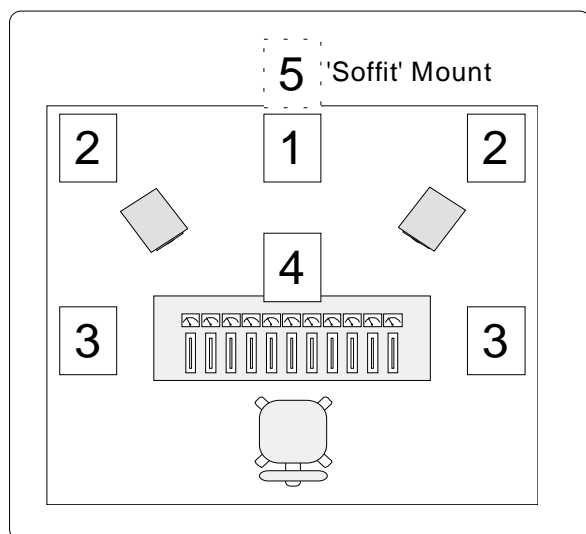

The figure to the left shows some example subwoofer positions within a room. Unless mentioned otherwise, the vents of the subwoofer should face towards the nearest wall.

- 1 Recommended position.
- 2 & 3 Recommended only when using two subwoofers.
- 4 This arrangement may cause a loss in low frequencies if the distance from the listening position to the front wall is between 1 and 3m.
- 5 The 'Soffit' or flush mount is also recommended. Here the vents must radiate into the room.

Figure 2. Subwoofer positioning

Positioning in the Room

The placement of the subwoofer in the room will affect the overall frequency response of the system as, with low frequencies, the effects of the room are more apparent.

The subwoofer radiation ports should be placed within 1m of a wall. The amplifier panel should not be positioned less than 10 cm from a surface, as this may cause heat dissipation problems from the amplifier back plate. The placement will affect the phase difference between the main monitors and the subwoofer, and also the bass roll-off rate. These effects can be compensated by the use of the controls in the amplifier unit; but consideration should be made when placing the subwoofer.

Choose a central and symmetrical position for the subwoofer as this will give an even phase match between all monitor channels. Positioning the subwoofer close to a corner should be avoided as it will boost the bass level at lower frequencies and may cause asymmetrical spatial imaging.

See the section titled 'Subwoofer Positioning' for examples of recommended positions within a room.

Safety Considerations

The 1094A/92A has been designed in accordance with international safety standards. However, to ensure safe operation and maintain the instrument under safe operating conditions the following warnings and cautions should be observed.

- Servicing and adjustment should only be performed by qualified service personnel.
- Opening the amplifier's rear panel is strictly prohibited except by such persons who are aware of the hazards involved.
- It is forbidden to use this product with an unearthed mains cable, which may lead to personal injury.

Warning!

This equipment is capable of delivering sound pressure levels in excess of 85dB, which may cause permanent hearing damage.

Overload Indicators

The 1094A contains a red 'Clip' LED. This indicator is located on the rear panel of the subwoofer. The clip LED will light if the amplifier is overloaded. If this occurs frequently, reduce the input level to the subwoofer until the clip LED stops blinking.

Setting the Phase Control

The effect of incorrect phase alignment between main monitors and subwoofer is a drop in the frequency response of the whole system at the crossover frequency. The graphs below (figure 3) show the effect of phase difference on the frequency response.

The phase difference between the main monitors and subwoofer at the listening position is dependent upon the position of the subwoofer in the listening room. For accurate system alignment in the room acoustic measuring equipment is required. If this equipment is not available to the user coarse phase matching can be applied.

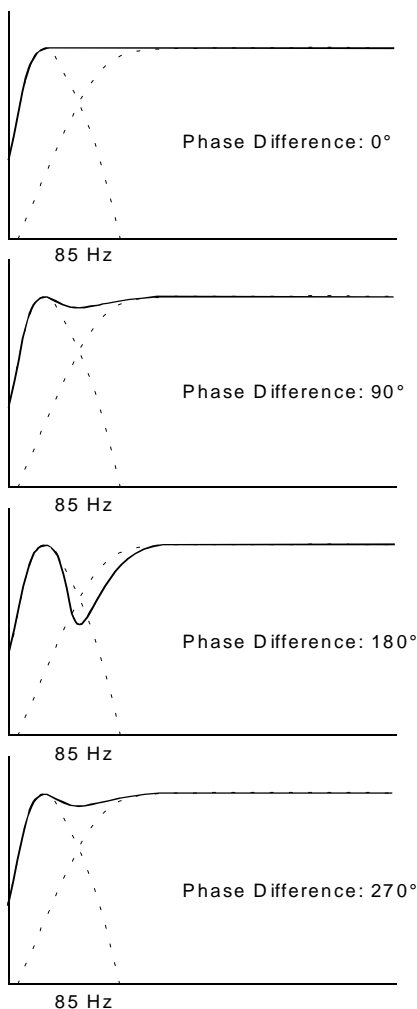

Figure 3. The effect of phase difference between the subwoofer and the main monitors

Coarse Phase Correction Method

The method to coarse align the phase of the system is as follows.

- Connect an audio frequency signal generator to one of the channels used in the system. If the signal generator has an unbalanced output use a cable with pin 3 grounded to pin 1 at the input as shown in figure 4 below.

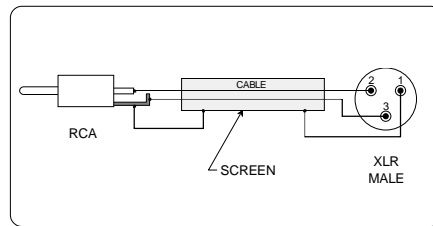

Figure 4. XLR to RCA connector for unbalanced operation.

- Set the frequency generator to 85Hz. If a signal generator is not available then it is possible to use an audio test recording with a test frequency in the range 70Hz to 100Hz.

- Toggle the -180° phase switch 'on' and 'off' and set it to the position which gives the lowest sound level at the listening position.



- Next toggle the -90° phase switch 'on' and 'off', and again set it to the position which gives the lowest sound level.



- Finally, set the -180° phase switch to the opposite setting.



Phase Correction Method with Test Equipment

If a frequency analyser and a pink noise generator are available then the following procedure can be used to match the phasing between the subwoofer and the main monitors.

Connect a high grade measuring microphone to the analyser and feed pink noise into the left main monitor. Position the microphone at the listening position and adjust the input sensitivity of the subwoofer until frequencies below and above 85 Hz are reproduced with equal level. Then adjust the phase control switches until a clear dip of at least -6dB can be seen at the crossover frequency (85 Hz).

If a dip appears at several switch positions select the one that gives the deepest reading. This should be the case where the phase difference between the subwoofer and the main monitors is at a maximum. To change the phase difference to a minimum the -180° switch should be moved to the opposite setting. The frequency analyser should now show the smoothest response around 85 Hz and the phase should now be set correctly. Repeat the above procedure with the right channel and possible centre channel main monitors.

Subwoofer Bypass Control

A bypass control feature is included into the subwoofer circuits so that the effect of the subwoofer on the whole monitor system can be determined. With the bypass switch on, the high pass filters for the main monitors are bypassed and the system behaves as if the subwoofer were not connected. The bypass remote controller is inserted into the $\frac{1}{4}$ inch jack socket located on the rear amplifier panel. See figure 5 for construction details.

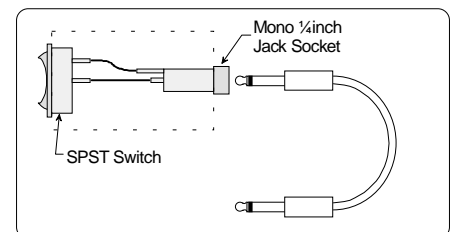
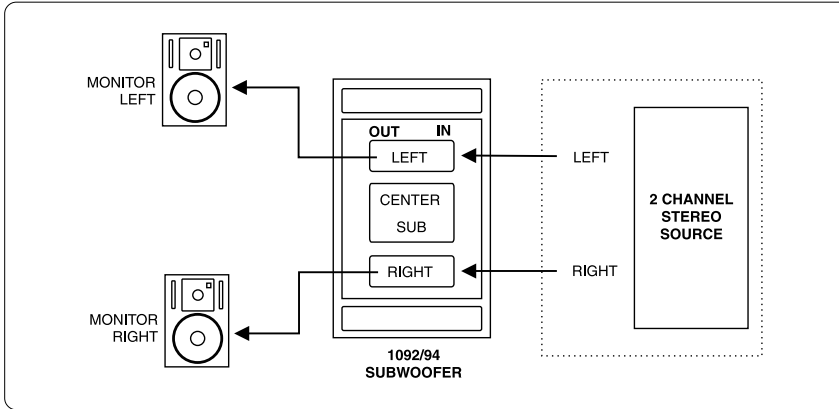

Figure 5. Bypass Remote Switch Construction.

System Connection

The following diagrams show the various ways the subwoofer can easily be included into an existing system. All connections to the subwoofer should be of the balanced XLR type to minimise the noise immunity of the speaker system. If an unbalanced source has

to be used then an RCA to XLR connection is required; the electrical connection diagram is shown in fig. 4.



Subwoofer in two channel Stereo mode.

Both left and right stereo channels are fed into the inputs of the subwoofer. Each subwoofer output is then connected to the corresponding main monitor.

Figure 6. One subwoofer in a two-channel system.

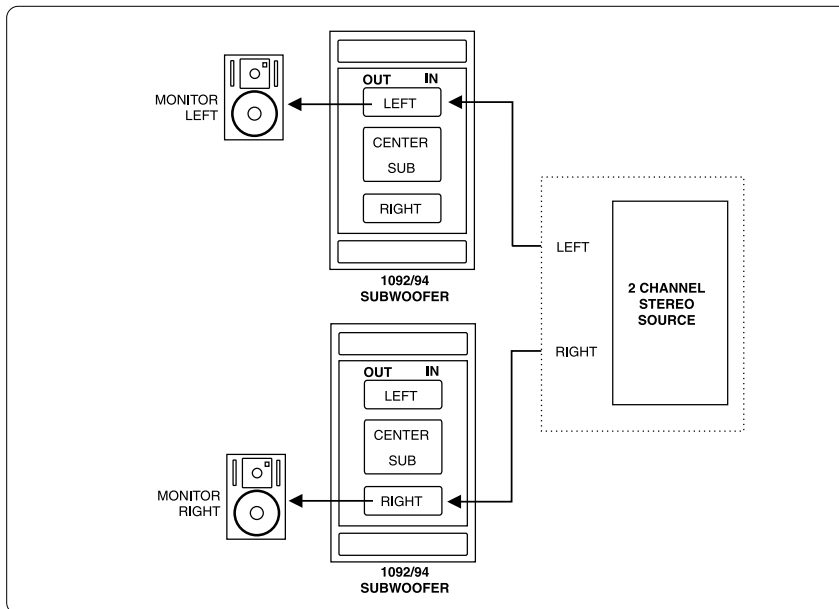

Two Subwoofers (stereo) in two channel Stereo mode.

To combine the two subwoofers into the system so that they produce stereo sub-bass signals, connect the system as shown to the left.

Figure 7. Two subwoofers (stereo) in a two-channel system.

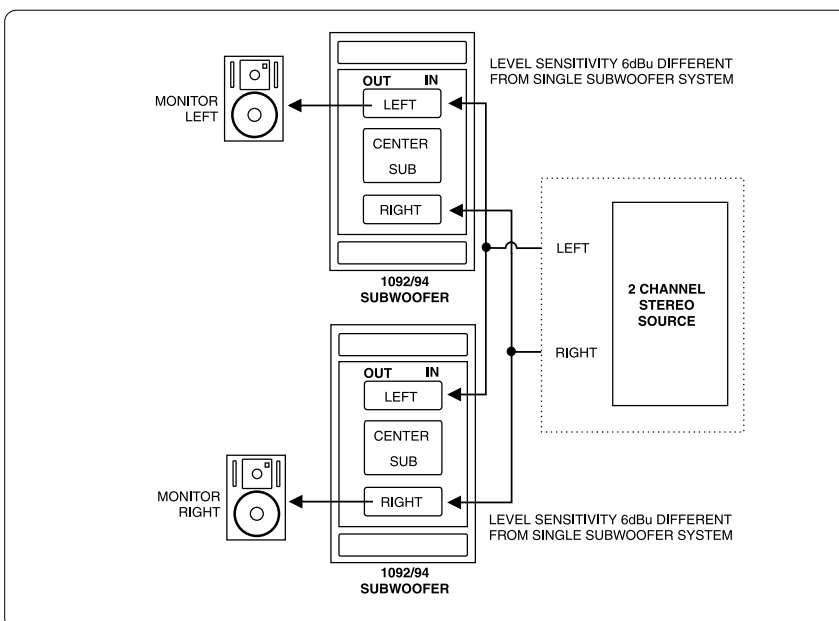

Two Subwoofers (mono) in two channel Stereo mode.

To combine the subwoofers into the system so that they produce mono sub-bass signals, connect the system as shown to the left.

Note that the level generated by the subwoofers will be 6dB greater than that generated by a single subwoofer, hence reduce the sensitivity control of each subwoofer by 6dBu, so that the level balance is maintained between the subwoofer and the main monitors.

Figure 8. Two subwoofers (mono) in a two-channel system

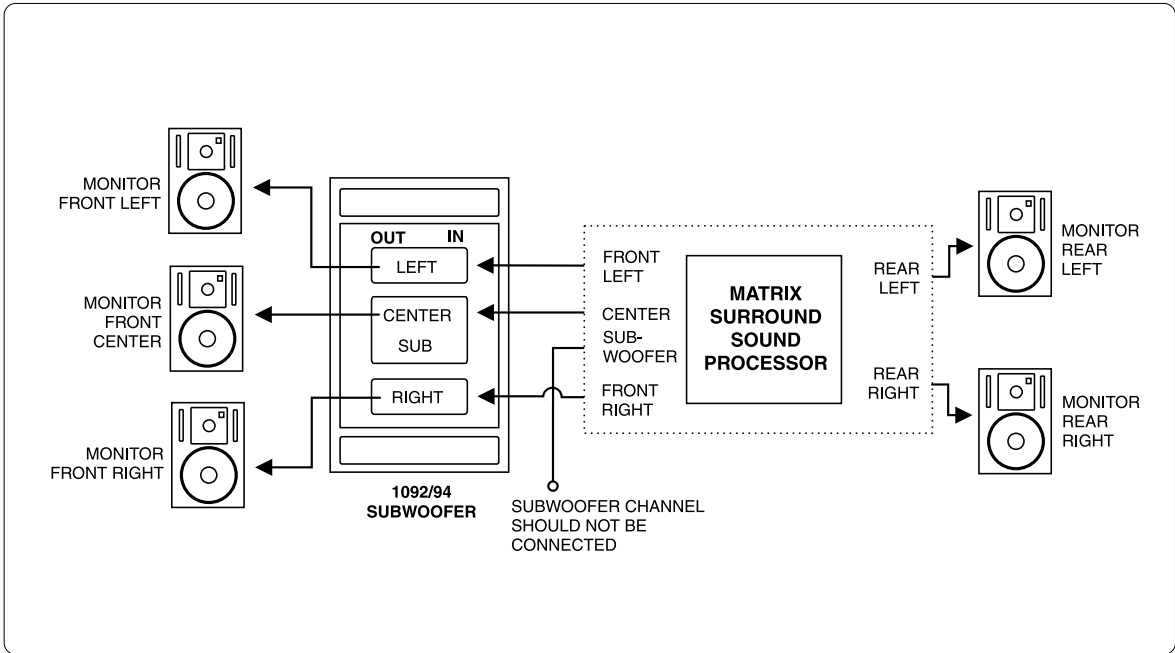

Figure 9. Subwoofer in an Analogue Matrix Surround Sound system

Subwoofer in Analogue Matrix Surround Sound systems.

When using a single subwoofer in an analogue matrix surround sound system, such as Dolby Surround or Dolby Pro-Logic, only the front three

channels should be connected to the subwoofer inputs (see figure 9 above). All front channels that are used should be connected via the subwoofer so that the output of the subwoofer is matched to the rest of the system. All other surround sound channels should be connected as normal.

If there is a subwoofer channel output on the decoder it should NOT be connected to the subwoofer speaker since the filtering within the decoder will effect the performance of the subwoofer.

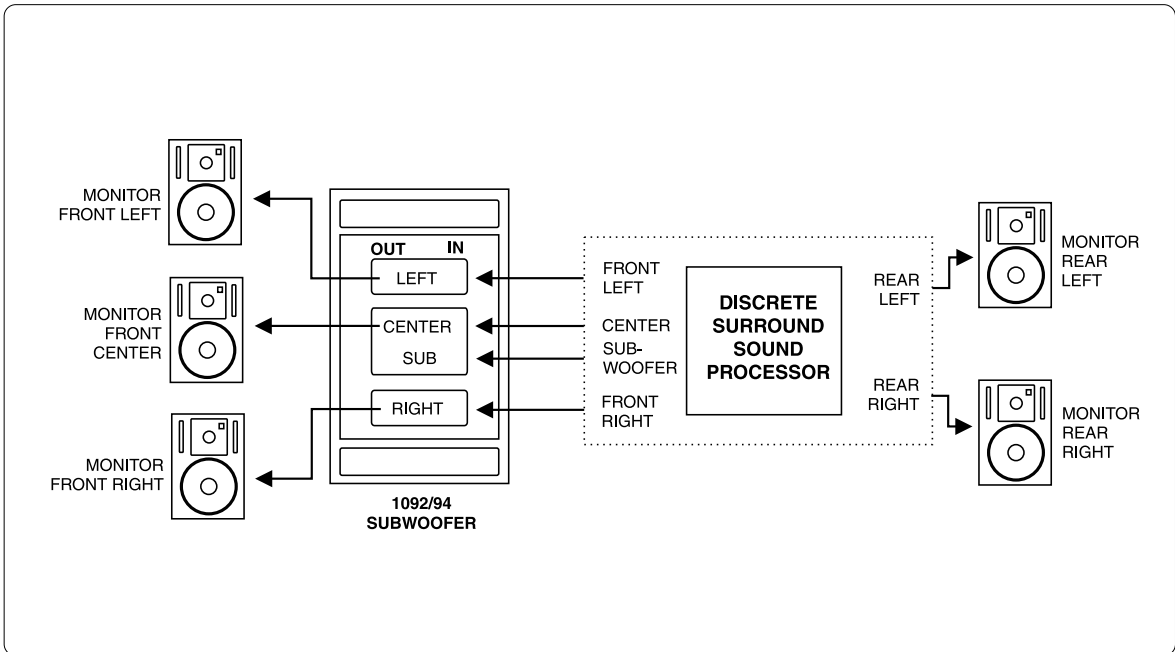

Figure 10. Subwoofer in a digital Discrete 5.1 Surround Sound system

Subwoofer in Digital Discrete 5.1 Surround Sound systems

Digital decoders, for example, Dolby Digital Surround (AC-3), DTS and DMAG2, have a discrete subwoofer channel output which should be

connected to the sub input on the 1092A or 1094A (see figure 10 above). This enables the subwoofer to correctly reproduce all the sub-bass information in the mix. Genelec Subwoofers can be used to good effect in "Discrete 5.1" system surround channels as they are wide band.

Digital decoders do not limit the bandwidth of the rear channels. If necessary, a second Genelec 1092A or 1094A subwoofer can be connected to the rear channels.

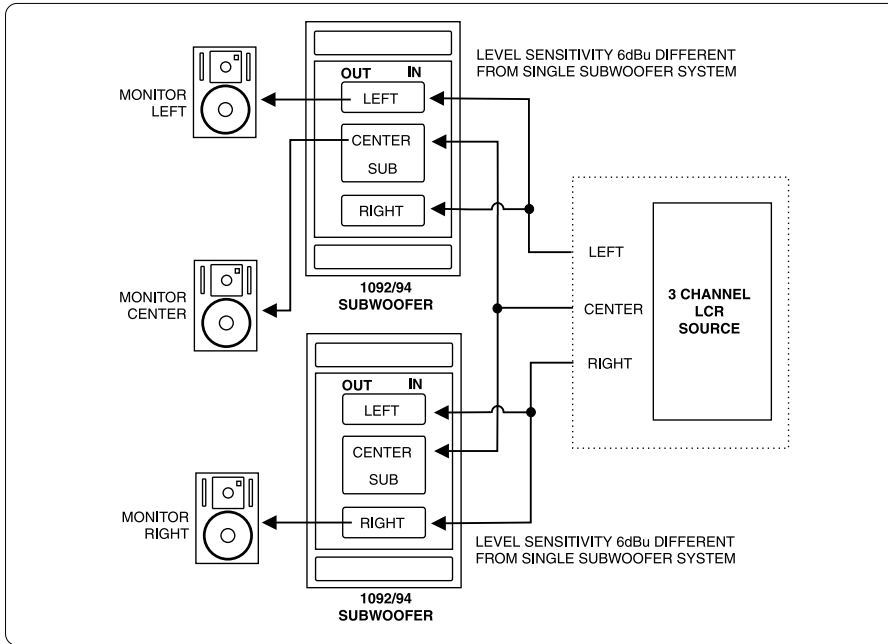

Figure 11. Two subwoofers (stereo) in a three-channel system

Two Subwoofers (stereo) in three channel LCR mode.

To combine the subwoofers into the system so that one subwoofer produces the left and centre bass signals, whilst the other produces the right and centre bass signals, connect the system as shown to the left.

Connection to the centre monitor can be made from either one of the subwoofer centre channels outputs. Note that as above the level sensitivity is 6dBu different from the single subwoofer system shown in figures 9 and 10.

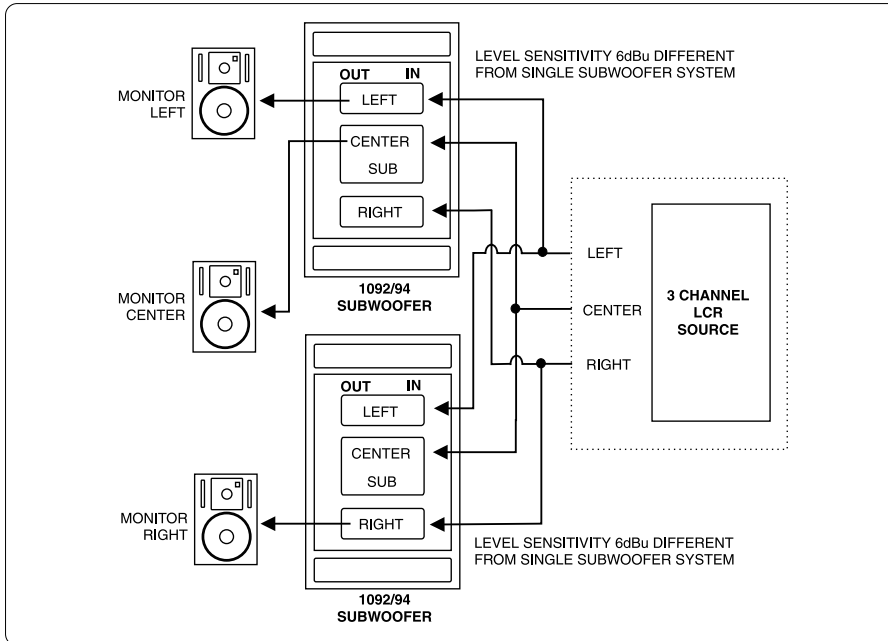

Figure 12. Two subwoofers (mono) in a three-channel system

Two Subwoofers (mono) in three channel LCR mode.

To combine the subwoofers into the system so that both subwoofers produce the bass signals for all three channels, connect the system as shown to the left.

Note that the level generated by the subwoofer will be 6dB greater than that generated by a single subwoofer. Hence the sensitivity control of both subwoofers should be turned down by 6dBu so that the level balance is maintained between the subwoofer and the main monitors.

Connection to the centre monitor can be made from either one of the subwoofer centre channel outputs.

Maintenance

No user serviceable parts are to be found within the amplifier unit. Any maintenance of the unit should only be undertaken by qualified service personnel. Ensure that if fuse replacement is required, only fuses of the appropriate voltage and current ratings are used. REMEMBER to disconnect the power supply by removing the mains cable before fuse replacement.

Guarantee

This product is supplied with a ONE year guarantee against manufacturing faults or defects that might alter the performance of the 1094A/1092A unit. Refer to supplier for full sales and guarantee terms. (Not applicable in the United States)

Accessories

Additional options available :

Bypass switch box	1092-400
1092 Magnetic shielding	1092-403
1094 Magnetic shielding	1094-403

GENELEC®

A C T I V E M O N I T O R I N G

SYSTEM

SPECIFICATIONS

	1094A	1092A
Free field frequency response of system (± 2.5 dB):	29 - 80 Hz	33 - 80 Hz
Maximum short term sine wave acoustic output in half space, averaged from 35 Hz to 85 Hz @ 1m:	≥ 120 dB SPL	≥ 115 dB SPL
Self generated noise level in free field @ 1m on axis (A-weighted)	≤ 10 dB	≤ 10 dB
Harmonic distortion at 100 dB SPL @ 1m on axis in half space (30...100 Hz):	< 3%	< 4%
Drivers:	385 mm (15")	2 x 210 mm (2 x 8")
Weight:	50 kg (110 lb)	30 kg (66 lb)
Dimensions:	Height	739 mm (29 ¹ / ₁₆ ")
	Width	468 mm (18 ⁷ / ₁₆ ")
	Depth	620 mm (24 ⁷ / ₁₆ ")

CROSSOVER SECTION

Both Models

Subsonic filter (18 dB/octave) below:	29 Hz	33 Hz
Crossover frequency, (sub/main monitors)		85 Hz
Crossover frequency, (sub input channel)		Full band/85 Hz
Crossover acoustical slope		
Lowpass:		28 dB/octave
Highpass:		12 dB/octave
Midband rejection, freq. ≥ 400 Hz:		≥ 50 dB
Bass roll-off control operating range in 2 dB steps:		from 0 to -6 dB @ 33 Hz
Phase matching control in 90° steps:		from 0° to -270° @ 85 Hz

AMPLIFIER SECTION

1094A 1092A

Short term amplifier output power:	400 W (8 Ohm)	180 W (4 Ohm)
(Long term output power is limited by driver unit protection circuitry.)		
Amplifier system distortion at nominal output:		
THD	$\leq 0.08\%$	$\leq 0.08\%$
SMPTE-IM	$\leq 0.08\%$	$\leq 0.08\%$
CCIF-IM	$\leq 0.08\%$	$\leq 0.08\%$
DIM 100	$\leq 0.08\%$	$\leq 0.08\%$
Signal to Noise ratio, referred to full output:	≥ 100 dB	≥ 100 dB
Mains voltage:	100/200 or 115/230V	
Voltage operating range:	$\pm 10\%$	
Power consumption (average):		
Idle	60 VA	50 VA
Full output	650 VA	300 VA

INPUT SECTION

Both Models

Input connectors: XLR female.	pin 1: gnd pin 2: + pin 3: -
Input impedance:	10 kOhm balanced
Input level for 100 dB SPL output @ 1m:	variable from +6 to -6 dBu

OUTPUT SECTION

Both Models

Output connectors: XLR male.	pin 1: gnd pin 2: + pin 3: -
Output impedance:	100 Ohm balanced, active floating
Gain:	0 dB

GENELEC®

Genelec Oy, Olvite 5
FIN - 74100 IISALMI, FINLAND
Phone: +358 - 17 - 813 311
Telefax: +358 - 17 - 812 267
Web: www.genelec.com
E-mail: genelec@genelec.com



Genelec Document DR920021
(1092-0106-3)
COPYRIGHT GENELEC OY 1998
All data subject to change without prior notice

Free Manuals Download Website

<http://myh66.com>

<http://usermanuals.us>

<http://www.somanuals.com>

<http://www.4manuals.cc>

<http://www.manual-lib.com>

<http://www.404manual.com>

<http://www.luxmanual.com>

<http://aubethermostatmanual.com>

Golf course search by state

<http://golfingnear.com>

Email search by domain

<http://emailbydomain.com>

Auto manuals search

<http://auto.somanuals.com>

TV manuals search

<http://tv.somanuals.com>