

GENERAC[®]

POWER SYSTEMS, INC.

Owner's Manual

GUARDIAN[™]
by **GENERAC** POWER SYSTEMS

Liquid-cooled, Prepackaged
Standby Generators

*** This Manual Should
Remain With The Unit ***

Models:

004373-1 (40 kW/Single-phase
w/ 200 Amp
Transfer Switch)

004626-0 (40 kW/Single-phase
w/ 200 Amp
Transfer Switch
California Emissions)

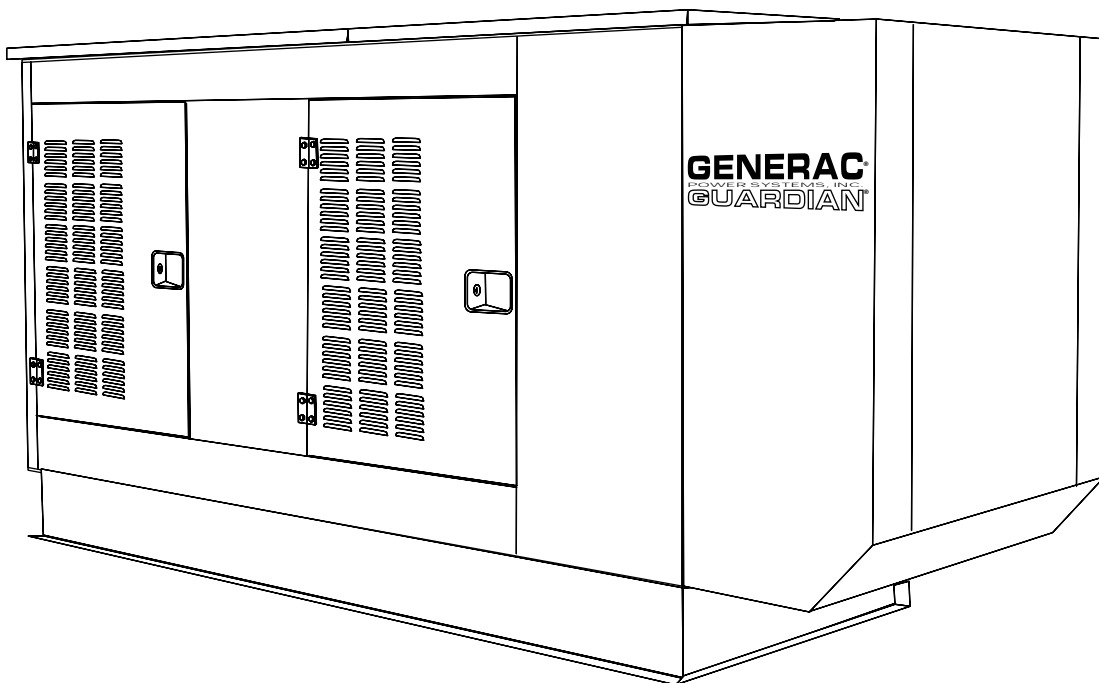

**ONLY QUALIFIED ELECTRICIANS OR CONTRACTORS
SHOULD ATTEMPT INSTALLATION!!**

INTRODUCTION

Thank you for purchasing the Guardian product line by Generac Power Systems. This model is a compact, high performance, liquid-cooled, engine-driven generator designed to automatically supply electrical power to operate critical loads during a utility power failure.

This unit is factory installed in an all-weather, metal enclosure that is intended exclusively for outdoor installation.

◆ READ THIS MANUAL THOROUGHLY

If you do not understand any portion of this manual, contact Generac or the nearest Generac/Guardian Authorized Dealer for starting, operating and servicing procedures.

Throughout this publication, and on tags and decals affixed to the generator, DANGER, WARNING, CAUTION and NOTE blocks are used to alert you to special instruction about a particular operation that may be hazardous if performed incorrectly or carelessly. Observe them carefully. Their definitions are as follows:

After this heading, read instructions that, if not strictly complied with, will result in personal injury or property damage.



After this heading, read instructions that, if not strictly complied with, may result in personal injury or property damage.



After this heading, read instructions that, if not strictly complied with, could result in damage to equipment and/or property.

NOTE:

After this heading, read explanatory statements that require special emphasis.

These safety warnings cannot eliminate the hazards that they indicate. Common sense and strict compliance with the special instructions while performing the service are essential to preventing accidents.

Four commonly used safety symbols accompany the DANGER, WARNING and CAUTION blocks. The type of information each indicates is as follows:

 This symbol points out important safety information that, if not followed, could endanger personal safety and/or property.

 This symbol points out potential explosion hazard.

 This symbol points out potential fire hazard.

 This symbol points out potential electrical shock hazard.

Generac® Power Systems, Inc.

The operator is responsible for proper and safe use of the equipment. Generac strongly recommends that the operator read this *Owner's Manual* and thoroughly understand all instructions before using this equipment. Generac also strongly recommends instructing other users to properly start and operate the unit. This prepares them if they need to operate the equipment in an emergency.

◆ CONTENTS

This manual contains pertinent owner's information, including warranty, electrical diagrams, exploded views and lists of repair parts, for Guardian models: 004373-1 & 004626-0.

◆ OPERATION AND MAINTENANCE

It is the operator's responsibility to perform all safety checks, to make sure that all maintenance for safe operation is performed promptly, and to have the equipment checked periodically by a Generac/Guardian Authorized Dealer. Normal maintenance service and replacement of maintenance parts are the responsibility of the owner/operator and, as such, are not considered defects in materials or workmanship within the terms of the warranty. Individual operating habits and usage contribute to the need for maintenance service.

Proper maintenance and care of the generator ensure a minimum number of problems and keep operating expenses at a minimum. See a Generac/Guardian Authorized Dealer for service aids and accessories.

◆ HOW TO OBTAIN SERVICE

When the generator requires servicing or repairs, simply contact a Generac/Guardian Authorized Dealer for assistance. Service technicians are factory-trained and are capable of handling all service needs.

When contacting a Generac/Guardian Authorized Dealer or the factory about parts and service, always supply the complete model number and serial number of the unit as given on its data decal, which is located on the generator.

Model No. _____ Serial No. _____

AUTHORIZED DEALER LOCATION

To locate the GENERAC/GUARDIAN AUTHORIZED
DEALER nearest you, please call this number:

1-800-747-1530

DEALER LOCATION INFORMATION
CAN BE OBTAINED AT THIS NUMBER.

IntroductionInside Front Cover
 Read This Manual ThoroughlyIFC
 ContentsIFC
 Operation and Maintenance.....IFC
 How to Obtain ServiceIFC
 Authorized Dealer Locator NumberIFC

Safety Rules2

Section 1 – General Information.....4

1.1 Unpacking/Inspection4
 1.1.1 Lifting the Generator4
 1.2 The Generator4
 1.3 Generator AC Connection Systems4
 1.4 Automatic System Operation.....4
 1.5 Main Circuit Breaker5
 1.6 Engine Protective Devices5
 1.6.1 Low Oil Pressure Switch5
 1.6.2 High Coolant Temperature Switch5
 1.6.3 Low Coolant Level Switch5
 1.6.4 Overspeed Shutdown5
 1.6.5 Overcrank Shutdown5
 1.6.6 DC Fuse.....5
 1.7 Specifications5
 1.7.1 Generator5
 1.7.1.1 Generator Load and Compatibility6
 1.7.2 Engine6
 1.8 Fuel Requirements and Recommendations6
 1.8.1 Conversion to LP Gas Vapor6
 1.9 Engine Oil Recommendations7
 1.10 Coolant7
 1.11 Emission Control System7

Section 2 – Installation8

2.1 Basic Standby Electric System8
 2.2 Emergency Circuit Isolation Method9
 2.3 Total Circuit Isolation Method.....9
 2.4 Grounding the Generator9
 2.5 Generator AC Neutral Connections9
 2.6 Transfer Switch Start Signal Connections....9
 2.6.1 “GTS” Type Switch9
 2.6.2 Pre-Packaged Type Switch.....9
 2.7 Battery Installation10
 2.7.1 Vented Batteries10
 2.8 Preparation Before Start-up10
 2.8.1 Prior to Initial Start-up11
 2.8.2 Transfer Switch11
 2.8.3 Fuel System11
 2.8.4 Generator Set Lubrication11
 2.8.5 Engine Coolant11
 2.8.6 Belt Tension11

2.8.7 Electrical System11
 2.8.8 Rodent Protection11

Section 3 – Operation12

3.1 Control Console Components12
 3.1.1 AC Voltmeter12
 3.1.2 AC Ammeter12
 3.1.3 AC Frequency Meter12
 3.1.4 DC Voltmeter.....12
 3.1.5 Hourmeter.....12
 3.1.6 Auto/Off/Manual Switch.....12
 3.1.7 Fault Indicator Lamp.....12
 3.1.8 15-amp Fuse12
 3.1.9 7.5 Amp Inline Fuse12
 3.1.10 Voltage-phase Selector Switch12
 3.1.11 Set Exercise Time Switch12
 3.2 Using the Auto/Off/Manual Switch12
 3.2.1 “Auto” Position.....12
 3.2.2 “Off” Position.....13
 3.2.3 “Manual” Position13
 3.3 Automatic Transfer Operation.....13
 3.4 Sequence of Automatic Operation13
 3.5 Engine Heater13
 3.6 Weekly Exercise Cycle14

Section 4 – Maintenance14

4.1 Checking the Engine Oil Level.....14
 4.2 Changing the Engine Oil and Filter15
 4.2.1 Engine Oil Recommendations15
 4.2.2 Oil and Filter Change Procedure15
 4.3 Changing the Engine Air Cleaner.....15
 4.4 Spark Plugs.....16
 4.5 Battery Maintenance16
 4.6 Cooling System17
 4.7 Overload Protection for Engine DC Electrical System.....17
 4.8 DC Fuse17
 4.9 Engine Coolant17
 4.10 Miscellaneous Maintenance17
 4.10.1 Cleaning the Generator17
 4.10.2 Rodent Protection18
 4.11 Out of Service Procedure18
 4.11.1 Removal From Service.....18
 4.11.2 Return to Service.....18
 4.12 Service Schedule19

Section 5 – Troubleshooting20

Section 6 – Electrical Data21-29

Section 7 – Exploded Views and Parts Lists30-54

Section 8 – Notes55

Section 9 – Installation Drawings.....56-57

Section 10 – WarrantyBack Cover



⚠ SAVE THESE INSTRUCTIONS - The manufacturer suggests that these rules for safe operation be copied and posted in potential hazard areas. Safety should be stressed to all operators and potential operators of this equipment. ⚠

⚠ SAVE THESE INSTRUCTIONS - This manual contains important instructions that should be followed during installation and maintenance of the generator and batteries. ⚠

⚠ WARNING: ⚠
The engine exhaust from this product contains chemicals known to the state of California to cause cancer, birth defects or other reproductive harm.
⚠ WARNING: ⚠
This product contains or emits chemicals known to the state of California to cause cancer, birth defects or other reproductive harm.

⚠ GENERAL HAZARDS ⚠

- For safety reasons, Generac recommends that the installation, initial start-up and maintenance of this equipment is carried out by a Generac/Guardian Authorized Dealer.
- Installation, operation, servicing and repair of this (and related) equipment must always comply with applicable codes, standards, laws and regulations. Adhere strictly to local, state and national electrical and building codes. Comply with regulations the Occupational Safety and Health Administration (OSHA) has established. Also, ensure that the generator is installed, operated and serviced in accordance with the manufacturer's instructions and recommendations. Following installation, do not do anything that might render the unit unsafe or in noncompliance with the aforementioned codes, standards, laws and regulations.
- The engine exhaust fumes contain carbon monoxide, which can be DEADLY. This dangerous gas, if breathed in sufficient concentrations, can cause unconsciousness or even death. For that reason, adequate ventilation must be provided. Exhaust gases must be piped safely away from any building or enclosure that houses the generator to an area where people, animals, etc., will not be harmed. This exhaust system must be installed properly, in strict compliance with applicable codes and standards.
- Keep hands, feet, clothing, etc., away from drive belts, fans, and other moving or hot parts. Never remove any drive belt or fan guard while the unit is operating.
- Adequate, unobstructed flow of cooling and ventilating air is critical in any room or building housing the generator to prevent buildup of explosive gases and to ensure correct generator operation. Do not alter the installation or permit even partial blockage of ventilation provisions, as this can seriously affect safe operation of the generator.
- Keep the area around the generator clean and uncluttered. Remove any materials that could become hazardous.
- When working on this equipment, remain alert at all times. Never work on the equipment when you are physically or mentally fatigued.

Study these SAFETY RULES carefully before installing, operating or servicing this equipment. Become familiar with this *Owner's Manual* and with the unit. The generator can operate safely, efficiently and reliably only if it is properly installed, operated and maintained. Many accidents are caused by failing to follow simple and fundamental rules or precautions.

Generac cannot possibly anticipate every possible circumstance that might involve a hazard. The warnings in this manual, and on tags and decals affixed to the unit are, therefore, not all-inclusive. If you use a procedure, work method or operating technique Generac does not specifically recommend, you must satisfy yourself that it is safe for you and others. You also must make sure the procedure, work method or operating technique that is chosen does not render the generator unsafe.

⚠ Despite the safe design of this generator, operating this equipment imprudently, neglecting its maintenance or being careless can cause possible injury or death. Permit only responsible and capable persons to operate or maintain this equipment.

⚠ Potentially lethal voltages are generated by these machines. Ensure all steps are taken to render the machine safe before attempting to work on the generator.

⚠ Parts of the generator are rotating and/or hot during operation. Exercise care near running generators.



- Inspect the generator regularly, and promptly repair or replace all worn, damaged or defective parts using only factory-approved parts.
- Before performing any maintenance on the generator, disconnect its battery cables to prevent accidental start-up. Disconnect the cable from the battery post indicated by a NEGATIVE, NEG or (-) first. Reconnect that cable last.
- Never use the generator or any of its parts as a step. Stepping on the unit can stress and break parts, and may result in dangerous operating conditions from leaking exhaust gases, fuel leakage, oil leakage, etc.
- Generators installed with an automatically transfer switch will crank and start automatically when normal (utility) source voltage is removed or is below an acceptable preset level. To prevent such automatic start-up and possible injury to personnel, disable the generator's automatic start circuit (battery cables, etc.) before working on or around the unit. Then, place a "Do Not Operate" tag on the generator control panel and on the transfer switch.
- In case of accident caused by electric shock, immediately shut down the source of electrical power. If this is not possible, attempt to free the victim from the live conductor. **AVOID DIRECT CONTACT WITH THE VICTIM.** Use a nonconducting implement, such as a rope or board, to free the victim from the live conductor. If the victim is unconscious, apply first aid and get immediate medical help.
- Never wear jewelry when working on this equipment. Jewelry can conduct electricity resulting in electric shock, or may get caught in moving components causing injury.

ELECTRICAL HAZARDS

- All generators covered by this manual produce dangerous electrical voltages and can cause fatal electrical shock. Utility power delivers extremely high and dangerous voltages to the transfer switch as does the standby generator when it is in operation. Avoid contact with bare wires, terminals, connections, etc., while the unit is running. Ensure all appropriate covers, guards and barriers are in place before operating the generator. If work must be done around an operating unit, stand on an insulated, dry surface to reduce shock hazard.
- Do not handle any kind of electrical device while standing in water, while barefoot, or while hands or feet are wet. **DANGEROUS ELECTRICAL SHOCK MAY RESULT.**
- If people must stand on metal or concrete while installing, operating, servicing, adjusting or repairing this equipment, place insulative mats over a dry wooden platform. Work on the equipment only while standing on such insulative mats.
- The National Electrical Code (NEC) requires the frame and external electrically conductive parts of the generator to be connected to an approved earth ground and/or grounding rods. This grounding will help prevent dangerous electrical shock that might be caused by a ground fault condition in the generator set or by static electricity. Never disconnect the ground wire.
- Wire gauge sizes of electrical wiring, cables and cord sets must be adequate to handle the maximum electrical current (ampacity) to which they will be subjected to.
- Before installing or servicing this (and related) equipment, make sure that all power voltage supplies are positively turned off at their source. Failure to do so will result in hazardous and possibly fatal electrical shock.
- Connecting this unit to an electrical system normally supplied by an electric utility shall be by means of a transfer switch so as to isolate the generator electric system from the utility electric system while in operation. Failure to isolate the two electric system power sources from each other by such means will result in damage to the generator and may also result in injury or death to utility power workers due to backfeed of electrical energy.

FIRE HAZARDS

- Keep a fire extinguisher near the generator at all times. DO NOT use any carbon tetra-chloride type extinguisher. Its fumes are toxic, and the liquid can deteriorate wiring insulation. Keep the extinguisher properly charged and be familiar with its use. If there are any questions pertaining to fire extinguishers, consult the local fire department.

EXPLOSION HAZARDS

- Properly ventilate any room or building housing the generator to prevent build-up of explosive gas.
- Do not smoke around the generator. Wipe up any fuel or oil spills immediately. Ensure that no combustible materials are left in the generator compartment, or on or near the generator, as FIRE or EXPLOSION may result. Keep the area surrounding the generator clean and free from debris.
- Generac generator sets may operate using one of several types of fuels. All fuel types are potentially FLAMMABLE and/or EXPLOSIVE and should be handled with care. Comply with all laws regulating the storage and handling of fuels. Inspect the unit's fuel system frequently and correct any leaks immediately. Fuel supply lines must be properly installed, purged and leak tested according to applicable fuel-gas codes before placing this equipment into service.
- Diesel fuels are highly FLAMMABLE. Gaseous fluids such as natural gas and liquid propane (LP) gas are extremely EXPLOSIVE. Natural gas is lighter than air, and LP gas is heavier than air; install leak detectors accordingly.

1.1 UNPACKING/INSPECTION

After unpacking, carefully inspect the contents for damage.

- This standby generator set has been factory installed in an all-weather, metal enclosure that is intended exclusively for outdoor installation.

⚠ WARNING ⚠

- ⚠ If this generator is used to power electrical load circuits normally powered by a utility power source, code requires to install a transfer switch. The transfer switch must effectively isolate the electrical system from the utility distribution system when the generator is operating (NEC 701). Failure to isolate an electrical system by such means will result in damage to the generator and also may result in injury or death to utility power workers due to backfeed of electrical energy.

If any loss or damage is noted at time of delivery, have the person(s) making the delivery note all damage on the freight bill or affix his or her signature under the consignor's memo of loss or damage.

If there is loss or damage after delivery, separate the damaged materials and contact the carrier for claim procedures.

“Concealed damage” is understood to mean damage to the contents of a package that is not in evidence at the time of delivery, but is discovered later.

◆ 1.1.1 LIFTING THE GENERATOR

⚠ WARNING ⚠

- ⚠ When lifting or hoisting equipment is used, be careful not to touch overhead power lines.
- ⚠ The generator's weight of more than 2,000 pounds requires proper tools and equipment, and qualified personnel to be used in all phases of handling and unpacking.

1.2 THE GENERATOR

This liquid-cooled, Guardian generator set is designed to supply electrical power to operate critical electrical loads during utility power failure. Use this generator as a source of electrical power for the operation of 120 and/or 240-volt, single-phase loads.

1.3 GENERATOR AC CONNECTION SYSTEMS

Figure 1.1 represents a single-phase, four-wire generator AC connection system. The stator assembly in this system consists of a pair of stationary windings with two leads brought out of each winding. Each single winding can supply a 120-volt, 60-Hertz AC output. When the two windings are connected in series, a 240-volt, 60-Hertz AC output results. Typically, the two “hot” leads in the circuit are Wires 11 and 44. The neutral leads are the junction of Wires 22 and 33.

Figure 1.1 – Single-phase Generator AC Connection System

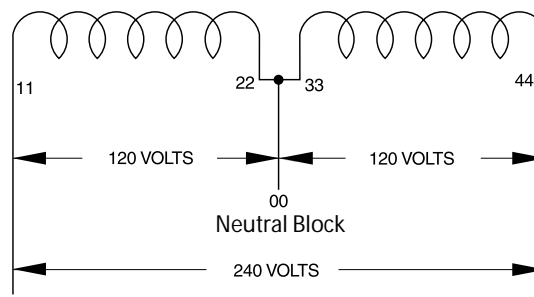

1.4 AUTOMATIC SYSTEM OPERATION

When this generator, along with its transfer switch, has been installed and interconnected, a circuit board in the generator panel continuously monitors utility power source voltage. Should that voltage drop below a preset value, and remain at such a low state for a preset amount of time, the generator cranks and starts. After the generator starts, the transfer switch transfers load circuits so the generator can power them.

When utility source voltage has been restored, the switch transfers back to the utility source voltage, and the generator then shuts down after a brief cool-down time.

1.5 MAIN CIRCUIT BREAKER

The generator's main circuit breaker is included with the unit as shipped from the factory. The breaker for each unit is described as follows:

Model Number	Circuit Breaker Rating
004373-1	200-amp breaker
004626-0	200-amp breaker

1.6 ENGINE PROTECTIVE DEVICES

The engine has several safety switches that cause it to automatically shut down under the following conditions: low oil pressure, high coolant temperature, low coolant level, engine overspeed and overcrank.

◆ 1.6.1 LOW OIL PRESSURE SWITCH

This switch is normally closed (N.C.) but is held open by engine oil pressure during engine running. Should operating oil pressure drop below approximately 10 psi (68 kPa), the switch contacts close, and the engine shuts down automatically (Figure 1.2).

Figure 1.2 – Engine Protective Devices

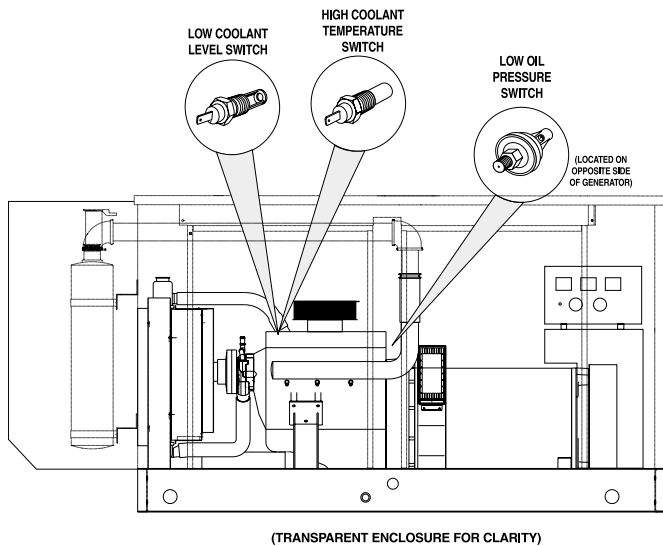

◆ 1.6.2 HIGH COOLANT TEMPERATURE SWITCH

This normally open (N.O.) thermostatic switch has a sensing tip that is immersed in captive coolant. Should the coolant temperature exceed approximately 121° C (250° F), the switch contacts close, which causes the engine to shut down automatically (Figure 1.2).

◆ 1.6.3 LOW COOLANT LEVEL SWITCH

Should the engine coolant level drop below the level of the high coolant temperature switch, it is possible for the engine to overheat without automatic shut down. To prevent such overheating without automatic shut down, the engine has a low coolant level sensor. If the engine coolant drops too low, the engine automatically shuts down (Figure 1.2).

◆ 1.6.4 OVERSPEED SHUTDOWN

The control module assembly (CMA) circuit board on liquid-cooled units receives AC frequency (rpm) signals directly from the stator AC power windings. Should AC frequency exceed approximately 72 Hertz, circuit board action will automatically shut down the engine.

◆ 1.6.5 OVERCRANK SHUTDOWN

After 90 seconds of crank-rest cycles (about seven seconds cranking/seven seconds at rest), this function ends cranking if the engine fails to start in that 90-second span.

◆ 1.6.6 DC FUSE

This fuse is located on the front panel of the control system. It protects the panel wiring and components from damaging overload. Always remove this fuse before commencing work on the generator. The unit will not start or crank if the fuse is blown. Replace the fuse with one of the same size, type, and rating. Generac uses an AGC fuse rated at 15 amps.

1.7 SPECIFICATIONS

◆ 1.7.1 GENERATOR

Models	004373-1 & 004626-0
Rated Maximum Continuous AC Power Output (kW)*	40
Rated Voltage (volts)	120/240
Rated Maximum Continuous Current at 240 Volts, Single-phase (amps)	167
Number of Rotor Poles	4
Driven Speed of Rotor (rpm)	1,800
Type of Stator	Four-wire
Rotor Excitation System	Direct Excited Brush-type System
Rotor and Stator Insulation	Class "H"

*Rated power of generator is subject to and limited by such factors as ambient temperature, altitude, engine condition and other factors. Engine power will decrease about 3.5 percent for each 1,000 feet above sea level; and also will decrease an additional 1 percent for each 6° C (10° F) above 15.5° C (60° F) ambient. Maximum output power of the generator is limited by maximum engine power.

◆ 1.7.1.1 Generator and Load Compatibility

The generator must be fully compatible with the rated voltage, number of phases and frequency of the connected electrical loads. The generator, connected electrical devices, or both, can be damaged if voltage, number of phases and frequency are not compatible.

Note:

This manual assumes that the standby generator has been properly selected, installed and interconnected by a competent, qualified electrician or installation contractor. Once the installation is complete, do nothing that may result in noncompatibility between the generator and connected electrical loads.

◆ 1.7.2 ENGINE

Make.....	General Motors
Displacement	4.3 liters (262 cu. in.)
Cylinder Arrangement	V-6
Valve Arrangement.....	Overhead Valves
Firing Order	1-6-5-4-3-2
Number of Main Bearings	4
Compression Ratio	9.4-to-1
No. of Teeth on Flywheel.....	168
Ignition System	Electronic
Ignition Timing at 1,800 rpm	40 degrees BTDC
Rated Horsepower at 1,800 rpm.....	67
Spark Plug Gap	0.045 inch (1.1 mm)
Recommended Spark Plugs	AC 41-932 or equivalent
Oil Pressure	30-50 psi
Crankcase Oil Capacity	4.5 U.S. quarts (4.25 L)
Recommended Engine Oil	SAE 15W-40
Type of Cooling System	Pressurized, closed recovery
Cooling Fan	Pusher Type
Cooling System Capacity	4.5 U.S. gallons (17 L)
Recommended Coolant	Use a 50-50 mixture of ethylene glycol and soft water.

Fuel Consumption

<u>Natural Gas</u>	
004373-1 & 004626-0	720 cfh
<u>LP Gas</u>	
004373-1 & 004626-0	288 cfh/7.9gph

1.8 FUEL REQUIREMENTS AND RECOMMENDATIONS

With LP gas, use only the vapor withdrawal system. This type of system uses the vapors formed above the liquid fuel in the storage tank.

Recommended fuels should have a Btu content of at least 1,000 Btus per cubic foot for natural gas; or at least 2,520 Btus per cubic foot for LP gas. Ask your fuel supplier for the Btu content of your fuel.

Fuel pressure for both natural gas and liquid propane setups should be 11 inches to 14 inches of water column (0.6 psi) at all load ranges.

—▲ **WARNING** ▲—

▲ Gaseous fuels such as natural gas and liquid propane (LP) gas are highly explosive. Even the slightest spark can ignite such fuels and cause an explosion. No leakage of fuel is permitted. Natural gas, which is lighter than air, tends to collect in high areas; LP gas is heavier than air and tends to settle in low areas – install leak detectors accordingly.

◆ 1.8.1 CONVERSION TO LP GAS VAPOR

The generator is shipped from the factory configured for using natural gas as fuel. To convert the fuel system to LP gas, proceed as follows (Figure 1.5).

1. Remove end cap from the pressure reducer valve.
2. Turn the tension screw counterclockwise until all tension is removed from the inner spring.
3. Install and tighten the end cap.
4. Invert the pressure reducer valve. In other words, turn it upside down (end cap facing downward).
5. Purge and leak test the entire fuel system according to gaseous fuel codes. NO LEAKS can appear at any point in the system.

Figure 1.5 – Conversion to LP Gas Vapor

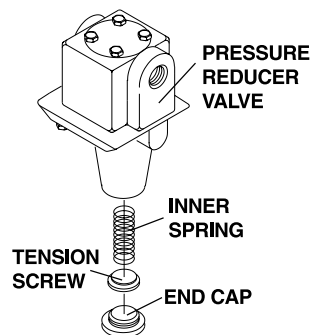

1.9 ENGINE OIL RECOMMENDATIONS

The unit has been filled with 15W-40 engine oil at the factory. Use a high-quality detergent oil classified "For Service CC, SD, SE or SF." Detergent oils keep the engine cleaner and reduce carbon deposits. Use oil having the following SAE viscosity rating, based on the ambient temperature range anticipated before the next oil change:

Temperature	Oil Grade(Recommended)
Above 80° F (27° C)	SAE 30W or 15W-40
32° to 80° F (-1° C to 27° C)	SAE 20W-20 or 15W-40
Below 32° F (0° C)	SAE 10W or 15W-40



▲ Any attempt to crank or start the engine before it has been properly serviced with the recommended oil may result in an engine failure.

1.10 COOLANT

Use a mixture of half low silicate, ethylene glycol base antifreeze and half soft water. Use only soft water and only low silicate antifreeze. If desired, add a high quality rust inhibitor to the recommended coolant mixture. When adding coolant, always add the recommended 50-50 mixture.

Do not remove the radiator pressure cap while the engine is hot or serious burns from boiling liquid or steam could result.

Ethylene glycol base antifreeze is poisonous. Do not use mouth to siphon coolant from the radiator, recovery bottle or any container. Wash hands thoroughly after handling. Never store used antifreeze in an open container because animals are attracted to the smell and taste of antifreeze even though it is poisonous to them.

Do not use any chromate base rust inhibitor with ethylene glycol base antifreeze, or chromium hydroxide ("green slime") will form and cause overheating. Engines that have been operated with a chromate base rust inhibitor must be chemically cleaned before adding ethylene glycol base antifreeze. Using any high silicate antifreeze boosters or additives also will cause overheating. Generac also recommends that any soluble oil inhibitor NOT be used for this equipment.

1.11 EMISSIONS CONTROL SYSTEM (Model 004626-0)

This model is equipped with an active exhaust emissions control system to comply with certain California air district regulations for natural gas emergency generating sets, including the South Coast Air Quality Management District. Do not tamper with or disable any part of this system, including the exhaust catalyst,

carburetor, oxygen sensor, air-fuel ratio controller, solenoid valve and gas regulator. These items are not subject to periodic maintenance or adjustment.

This model is of a size (greater than 50 brakehorsepower) that may require a review by air permitting authorities prior to installation and operation. Consult the local air management district for details and specific requirements.

Figure 1.3 - Emissions Control System

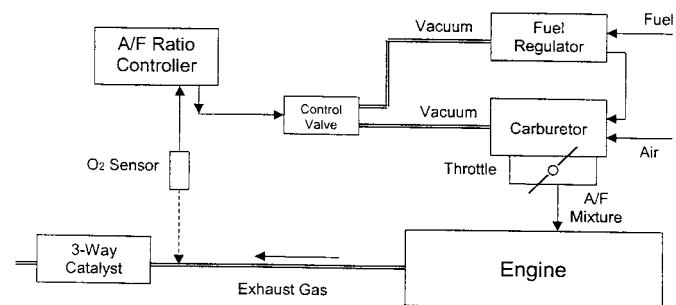



AIR FUEL RATIO CONTROLLER

The air fuel ratio controller is an advanced micro-processor designed to work with a three-way catalyst and a feedback (rich bias) carburetor to provide close-loop fuel management. Its digital adaptive control is able to compensate for variations in fuel mixtures and engine tunes. It is time based activated. (For example, it will activate after 45 seconds from receiving the power signal.) The part number for the air fuel ratio controller is 0D4221.

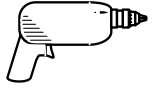
Principle of Operation: The oxygen sensor, installed on the exhaust pipe, between the engine and the catalytic muffler (closer to the engine), continuously monitors the exhaust gas composition. A feedback signal is sent from the oxygen sensor to the air fuel ratio controller, which controls the fuel system to maintain the optimal, stoichiometric air fuel ratio. The air fuel mixture to the engine is controlled by biasing the diaphragm in the fuel regulator using vacuum (from the carburetor). This vacuum signal is directed to the fuel regulator via the control valve. The air fuel ratio controller determines the amount of vacuum signal sent to the fuel regulator. The more vacuum sent to the regulator, the more restricted the fuel flow will be, therefore the leaner the air fuel mixture.



STANDBY GENERATOR INSTALLATION

 Connecting this generator to an electrical system normally supplied by an electric utility shall be by means of a transfer switch (such as the Generac “GTS” type transfer switch), so as to isolate the electric system from the utility distribution system when the generator is operating. Failure to isolate the electric system by these means will result in damage to the generator and may also result in injury or death to utility workers due to backfeed of electrical energy. 

—  CAUTION  —

 If an open bottom is used, the engine-generator is to be installed over non-combustible materials and should be located such that combustible materials are not capable of accumulating under the generator set.

Only qualified, competent installation contractors or electricians thoroughly familiar with applicable codes, standards and regulations should install this standby electric power system. The installation must comply strictly with all codes, standards and regulations pertaining to the installation.

—  CAUTION  —

After the system has been installed, you must not do anything that might render the installation in noncompliance with such codes, standards and regulations.

NOTE:

For more information about the installation of a standby system, you can order *Engine-Generator Standby Electric Power Systems Installer’s Guide and Reference Manual* (part #046622) from a Generac Authorized Service Dealer.

◆ NFPA STANDARDS

The following published standards booklets pertaining to standby electric systems are available from the National Fire Protection Association (NFPA), Batterymarch Park, Quincy, MA 02269:

- NFPA No. 37, STATIONARY COMBUSTION ENGINES AND GAS TURBINES.
- NFPA No. 76A, ESSENTIAL ELECTRICAL SYSTEMS FOR HEALTH CARE FACILITIES.
- NFPA No. 220, STANDARD TYPES OF BUILDING CONSTRUCTION
- NFPA No. 68, GUIDE FOR EXPLOSION VENTING
- NFPA No. 70, NATIONAL ELECTRICAL CODE.
- NFPA No. 30, FLAMMABLE AND COMBUSTIBLE LIQUIDS CODE.
- NFPA No. 10, INSTALLATION, MAINTENANCE AND USE OF PORTABLE FIRE EXTINGUISHERS.

◆ OTHER PUBLISHED STANDARDS

In addition to NFPA standards, the following information pertaining to the installation and use of standby electric systems is available:

- Article X, NATIONAL BUILDING CODE, available from the American Insurance Association, 85 John Street, New York, N.Y. 10038.
- AGRICULTURAL WIRING HANDBOOK, obtainable from the Food and Energy Council, 909 University Avenue, Columbia, MO, 65201.
- ASAE EP-364.2, INSTALLATION AND MAINTENANCE OF FARM STANDBY ELECTRIC POWER, available from the American Society of Agricultural Engineers, 2950 Niles Road, St. Joseph, MI 49085.
- A52.1, AMERICAN NATIONAL STANDARD FOR CHIMNEYS, FIREPLACES AND VENTING SYSTEMS, available from the American National Standard Institute, 1430 Broadway, New York, N.Y. 10018.
- NEC HANDBOOK available from the National Fire Protection Association, 1 Batterymarch Park, PO Box 9146, Quincy, MA 02269-9959.

2.1 BASIC STANDBY ELECTRIC SYSTEM

Figure 2.1 shows a schematic diagram of a basic standby electric system. Both the UTILITY power supply and the STANDBY (generator) output are connected to an approved transfer switch. The transfer switch is required by electrical code and serves the following functions:

- Permits the LOAD circuits to be connected to only one power supply at a time.
- Prevents electrical backfeed between STANDBY power and the UTILITY power circuits.

Notice that both the STANDBY and the UTILITY power supplies to the transfer switch are protected against overload by a main line circuit breaker.

NOTE:

Generac recommends the use of a Generac Power Systems “pre-packaged” type transfer switch (Part No. 0D4406) in conjunction with this generator.

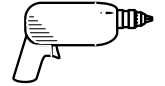
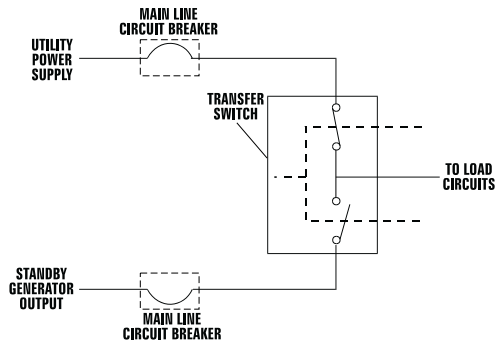

Figure 2.1 – Basic Standby Electric System



⚠ Do not connect the ground wire to any pipe that carries a flammable or explosive substance – FIRE or an EXPLOSION may result.

Proper grounding helps protect personnel against electrical shock in the event of a ground fault condition in the generator or in connected electrical devices. In addition, grounding helps dissipate static electricity that often builds up in ungrounded devices.

Figure 2.2 – Generator Grounding Lug (typical)

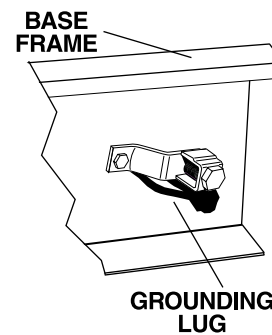

2.2 EMERGENCY CIRCUIT ISOLATION METHOD

This prevents overloading the generator by keeping electrical loads below the wattage/amperage capacity of the generator. If the generator is powering only critical loads, within its wattage/amperage capacity, during utility power outages, consider using the emergency circuit isolation method.

Critical electrical loads are grouped together and wired into a separate “Emergency Distribution Panel.” Load circuits powered by that panel are within the wattage/amperage capacity of the generator set. When this method is used, it is difficult to overload the generator. The transfer switch must meet the following requirements:

- It must have an ampere rating equal to or greater than the total amperage rating of the emergency distribution panel circuit.
- It must be installed between the building’s main distribution panel and the emergency distribution panel.

2.3 TOTAL CIRCUIT ISOLATION METHOD

When a generator capable of powering all electrical loads in the circuit is to be installed, use the “Total Circuit Isolation Method.” It is possible for the generator to be overloaded when this isolation method is employed. The following apply to the transfer switch in this type of system.

- Ampere rating of the transfer switch must be equal to or greater than the ampere rating of the normal incoming utility service.
- The transfer switch must be installed between the utility service entrance and the building distribution panel.

2.4 GROUNDING THE GENERATOR

The National Electrical Code requires the frame and external electrically conductive parts of this equipment to be properly connected to an approved earth ground and/or grounding rods. For that purpose, a GROUND LUG (Figure 2.2) is provided on the generator mounting base. Consult a qualified electrician for grounding requirements in your area. Grounding procedures must meet local regulations.

2.5 GENERATOR AC NEUTRAL CONNECTIONS

Generac uses an UNGROUNDED AC neutral. Grounding is recommended only at the main service entrance.

2.6 TRANSFER SWITCH START SIGNAL CONNECTIONS

■ 2.6.1 “GTS” Type Switch

Connect the two-wire start signal from the automatic transfer switch to the automatic start connection, which is located in the right hand corner inside the lower panel. Match wires 178 and 183 in the transfer switch to 178 and 183 on the terminal strip in the control panel. The conductors for the two-wire start circuit must be in their own conduit.

■ 2.6.2 Pre-Packaged Type Switch

Connect the six signal wires from the automatic transfer switch to the engine generator control, which is located on the upper right side and inside the lower control panel. Match wires 23, 194, N1, N2, T1 and T2 in the transfer switch to the corresponding wires on the terminal strip in the lower panel. The conductors for these wires must be in separate conduit from the main AC output wires.

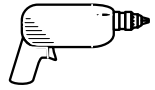

2.7 BATTERY INSTALLATION

⚠ Standby generators installed with automatic transfer switches will crank and start automatically when normal (utility) source voltage is removed or is below an acceptable preset level. To prevent such automatic start-up and possible injury to personnel, do not connect battery cables until the normal source voltage at the transfer switch is correct and the system is ready to be placed into operation.

⚠ Storage batteries give off explosive hydrogen gas. This gas can form an explosive mixture around the battery for several hours after charging. The slightest spark can ignite the gas and cause an explosion. Such an explosion can shatter the battery and cause blindness or other injury. Any area that houses a storage battery must be properly ventilated. Do not allow smoking, open flame, sparks or any spark producing tools or equipment near the battery.

⚠ Battery electrolyte fluid is an extremely caustic sulfuric acid solution that can cause severe burns. Do not permit fluid to contact eyes, skin, clothing, painted surfaces, etc. Wear protective goggles, protective clothing and gloves when handling a battery. If fluid is spilled, flush the affected area immediately with clear water.

— **⚠ WARNING** ⚠ —

⚠ Do not dispose of the battery in a fire. The battery is capable of exploding.

⚠ Do not open or mutilate the battery. Released electrolyte can be toxic and harmful to the skin and eyes.

⚠ The battery represents a risk of high short circuit current. When working on the battery, always remove watches, rings or other metal objects, and only use tools that have insulated handles.

2.7.1 VENTED BATTERIES

— **⚠ CAUTION** ⚠ —

⚠ The electrolyte is a dilute sulfuric acid that is harmful to the skin and eyes. It is electrically conductive and corrosive. The following procedures are to be observed:

- Wear full eye protection and protective clothing,
- Where electrolyte contacts the skin, wash it off immediately with water,

- Where electrolyte contacts the eyes, flush thoroughly and immediately with water and seek medical attention, and
- Spilled electrolyte is to be washed down with an acid-neutralizing agent. A common practice is to use a solution of one pound (500 grams) bicarbonate of soda to one gallon (4 liters) of water. The bicarbonate of soda solution is to be added until the evidence of reaction (foaming) has ceased. The resulting liquid is to be flushed with water and the area dried.

⚠ Lead acid batteries present a risk of fire because they generate hydrogen gas. The following procedures are to be followed:

- DO NOT SMOKE when near batteries,
- DO NOT cause flame or spark in battery area, and
- Discharge static electricity from body before touching batteries by first touching a grounded metal surface.

Servicing of batteries is to be performed or supervised by personnel knowledgeable of batteries and the required precautions. Keep unauthorized personnel away from batteries.

For recommended batteries, see “Battery Maintenance” page 16. All batteries must be at 100 percent state-of-charge before they are installed on the generator.

When using maintenance-free batteries, it is not necessary to check the specific gravity or electrolyte level. Have these procedures performed at the intervals specified in Section 4, “Maintenance.” A negative ground system is used. Battery connections are shown on the wiring diagrams. Make sure all batteries are correctly connected and terminals are tight. Observe battery polarity when connecting batteries to the generator set.

Note:

Damage will result if the battery connections are reversed.

2.8 PREPARATION BEFORE START-UP

The instructions in this section assume that the standby generator has been properly installed, serviced, tested, adjusted and otherwise prepared for use by a competent, qualified installation contractor. Be sure to read the “Safety Rules” on Pages 2 and 3, as well as all other safety information in this manual, before attempting to operate this (and related) equipment.

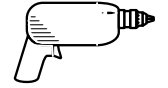

2.8.1 PRIOR TO INITIAL START-UP



⚠ Prior to initially starting the generator, it must be properly prepared for use. Any attempt to crank or start the engine before it has been properly serviced with the recommended types and quantities of engine fluids (oil, coolant, fuel, etc.) may result in an engine failure.

Before starting the generator for the first time, the installer must complete the following procedures. For follow-up maintenance information and/or service intervals, please refer to Section 4, "Maintenance."

2.8.2 Transfer Switch

If this generator is used to supply power to any electrical system normally powered by an electric utility, the National Electrical Code requires that a transfer switch be installed. The transfer switch prevents electrical backfeed between two different electrical systems. (For additional information, see the applicable transfer switch manual for this unit.) The transfer switch, as well as the generator and other standby components, must be properly located and mounted in strict compliance with applicable codes, standards and regulations.

2.8.3 Fuel System

Make sure the fuel supply system to the generator (a) delivers the correct fuel at the correct pressure and (b) is properly purged and leak tested according to code. No fuel leakage is permitted. See "Specifications" (Page 6) for more information.

2.8.4 Generator Set Lubrication

Check the engine crankcase oil level before operating and add oil to the proper level – the dipstick "FULL" mark. Never operate the engine with the oil level below the dipstick "ADD" mark. See "Specifications" (Page 5) and "Engine Oil Recommendations" (Page 7).

NOTE:

This engine is shipped from the manufacturer with SAE 15W-40 oil. This oil should be changed after 30 hours of operation.

2.8.5 Engine Coolant

Have the engine cooling system properly filled with the recommended coolant mixture. Check the system for leaks and other problems. See "Specifications" (Page 5) and "Coolant" (Page 7).

2.8.6 Belt Tension

Check the engine fan belt tension and condition prior to placing the unit into service and at recommended intervals. Belt tension is correct when a force of approximately 22 pounds (10 kg), applied midway between pulleys, deflects the belt about 3/8- to 5/8-inch (10 to 16 mm).

2.8.7 Electrical System

Make sure the generator is properly connected to an approved earth ground and/or ground rod.

Make sure the generator battery is fully charged, properly installed and interconnected, and ready for use.

Check to ensure that there are no loose electrical connections. Restrain any loose wires to keep them clear of any moving generator set components.

2.8.8 Rodent Protection

Make sure the four 3-inch diameter cap plugs (part # 0A8785) are properly installed in the tie-down holes in the side rails of the unit's base frame (Figure 2.3). The cap plugs are shipped in a plastic bag located in the lower connection box. These plugs are needed to prevent rodents from accessing the interior of the generator set. On acoustic units, cap plugs also are needed to stay within noise specification limits.

Figure 2.3 - Base Frame Cap Plugs

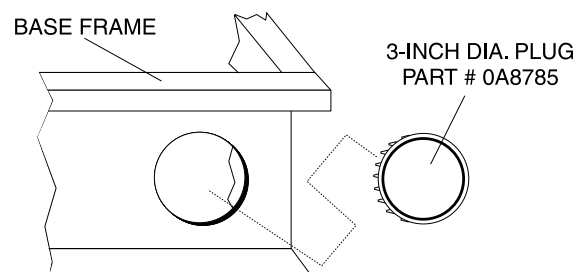

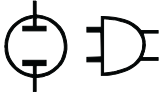

3.1 CONTROL CONSOLE COMPONENTS

The components of a liquid-cooled generator control console (Figure 3.1) are as follows:

Figure 3.1 – Control Console

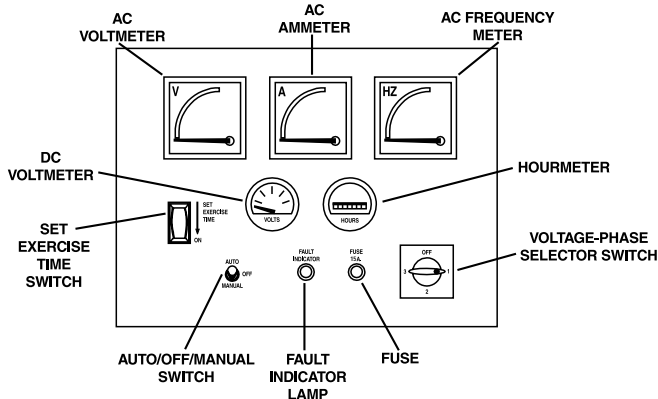

◆ 3.1.1 AC VOLTMETER

The voltmeter displays generator AC output voltage during operation. Voltage is regulated by a solid-state voltage regulator and is proportional to AC frequency. Refer to the unit's DATA PLATE for rated AC voltage.

◆ 3.1.2 AC AMMETER

This indicates current draw of connected electrical loads during operation. DO NOT EXCEED THE UNIT'S RATED MAXIMUM CONTINUOUS CURRENT. Refer to the unit DATA PLATE.

◆ 3.1.3 AC FREQUENCY METER

This indicates generator AC output frequency in Hertz (cycles per second). Frequency is proportional to engine speed. Units with a four-pole rotor, supply 60 Hertz at 1,800 rpm. The frequency reading with no electrical loads connected (no-load condition) should be between 60-62 Hertz.

◆ 3.1.4 DC VOLTMETER

The generator is equipped with a belt-driven DC alternator, which maintains battery state of charge when the engine operates. The control module assembly (CMA) also incorporates a trickle charge circuit that maintains battery state of charge during nonoperating periods. Battery voltage should read approximately 12.5 to 14.5 volts DC. A low battery voltage indicates the battery is discharging.

◆ 3.1.5 HOURMETER

This indicates the time the engine-generator has operated, in hours and tenths of hours. Use the hourmeter along with the periodic maintenance schedule for your generator set.

◆ 3.1.6 AUTO/OFF/MANUAL SWITCH

See Section 3.2.

◆ 3.1.7 FAULT INDICATOR LAMP

This lamp goes ON when one or more of the following engine faults occurs and when engine shuts down.

- Low oil pressure
- High coolant temperature
- Low coolant level
- Overcrank
- Overspeed

◆ 3.1.8 15-AMP FUSE

This fuse protects the control console's DC control circuit against electrical overload. If the fuse has melted open because of an overload, engine cranking and start-up cannot occur. Replace the fuse with an identical AGC 15-amp replacement fuse.

◆ 3.1.9 7.5 AMP INLINE FUSE (NOT SHOWN)

This inline fuse is connected in the 15A line that runs between the Auto/Off/Manual switch and position 10 of the 76009A PCB. This fuse protects the start, fuel, field boost, and transfer outputs from the PCB and will open if there is excessive current draw on any one of these outputs.

◆ 3.1.10 VOLTAGE-PHASE SELECTOR SWITCH

This switch permits selection between either line-to-line or line-to-neutral voltage and amperage readings on the console AC voltmeter and AC ammeter.

◆ 3.1.11 SET EXERCISE TIME SWITCH

This switch allows to program the generator to start and exercise automatically. (See Section 3.6, page 14)

3.2 USING THE AUTO/OFF/MANUAL SWITCH

◆ 3.2.1 "AUTO" POSITION

Selecting this switch position activates fully automatic system operation. It also allows the unit to start and exercise the engine every seven days with the setting of the exercise timer.



◆ 3.2.2 "OFF" POSITION

This switch position shuts down the engine. This position also prevents operation.

◆ 3.2.3 "MANUAL" POSITION

Set the switch to Manual to crank and start the engine. Transfer to standby power will not automatically occur unless there is a utility failure.

—▲ WARNING ▲—

▲ With the switch set to AUTO, the engine may crank and start at any time without warning. Such automatic starting normally occurs when utility power source voltage drops below a preset level or during the normal exercise cycle. To prevent possible injury that might be caused by such sudden starts, always set the switch to OFF and remove the fuse before working on or around the generator or transfer switch. Then, place a "Do Not Operate" tag on the generator panel and on the transfer switch.

3.3 AUTOMATIC TRANSFER OPERATION

To select automatic operation, do the following:

1. Make sure the transfer switch main contacts are set to their "Utility" position, i.e., loads connected to the utility power source.
2. Be sure that normal utility power source voltage is available to transfer switch terminal lugs N1 and N2.
3. Set the generator's Auto/Off/Manual switch to AUTO.
4. Set the generator's main circuit breaker to its ON (or closed) position.

With the preceding steps complete, the generator will start automatically when utility source voltage drops below a preset level. After the unit starts, loads are transferred to the standby power source. Refer to "Sequence of Automatic Operation."

3.4 SEQUENCE OF AUTOMATIC OPERATION

The generator's control panel houses a control logic circuit board. This board constantly monitors utility power source voltage. Should that voltage drop below a preset level, circuit board action will signal the engine to crank and start. After the engine starts, the circuit board signals the transfer switch to activate and connect load circuits to the standby power supply (load terminal lugs T1/T2 connect to terminal lugs E1/E2).

Upon restoration of utility source voltage above a preset level, generator circuit board action signals the transfer switch to transfer loads back to that power supply. After retransfer, the engine is signalled to shut down.

The actual sequence of operation is controlled by sensors and timers on a control logic circuit board, as follows:

A. Utility Voltage Dropout Sensor

- This sensor monitors utility source voltage.
- If utility source voltage drops below about 60 percent of the nominal supply voltage, the sensor energizes a 15-second timer.
- Once the timer has expired, the engine will crank and start.

B. Engine Warm-up Time Delay

- This mechanism lets the engine warm up for about 10 seconds before the load is transferred to a standby source.

C. Standby Voltage Sensor

- This sensor monitors generator AC output voltage. When the voltage has reached 50 percent of the nominal rated voltage, transfer to standby can occur.

D. Utility Voltage Pickup Sensor

- This sensor monitors utility power supply voltage. When that voltage is restored above 80 percent of the nominal source voltage, a retransfer time delay starts timing.

E. Retransfer Time Delay

- This timer runs for about 15 seconds.
- At end of a 15-second delay, circuit board action de-energizes transfer relay in the transfer switch.
- Retransfer to utility power source then occurs.

F. Engine Cool-down Timer

- When the load is transferred back to utility power source, the engine cool-down timer starts timing.
- The timer will run for about one minute, and the generator will then shut down.

3.5 ENGINE HEATER

This Generac standby generator comes equipped with a block heater (Figure 3.2, page 14) that is similar to the block heaters used in automotive applications.

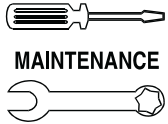
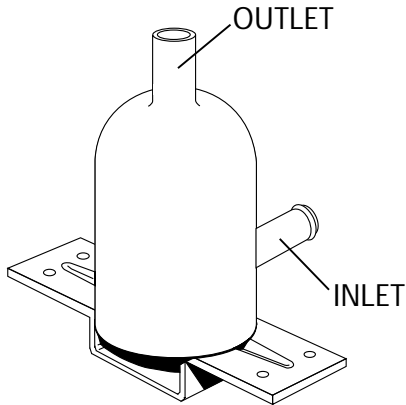

Figure 3.2 – Engine Block Heater



Refer to applicable wiring diagram(s) and electrical schematic(s) at the back of this manual for wiring connections.

3.6 WEEKLY EXERCISE CYCLE

The generator will start and exercise once every seven days. During this weekly exercise, the unit runs for approximately 20 minutes and shuts down. Transfer of loads to generator output does not occur during the exercise unless power is lost during the exercise period.

To select the day of the week and time of day for exercising, proceed as follows:

- Set the Auto/Off/Manual switch to OFF.
- Set generator's main circuit breaker to its OFF (or open) position.
- Locate the rocker switch on the control panel identified with the words "Set Exercise Time" (Figure 3.3).
- Push "Set Exercise Time" switch to the ON position for 20 to 30 seconds and then release. The switch will spring back into its original position when released.
- Wait 30 seconds before setting the Auto/Off/Manual switch to the AUTO position.

NOTE:

The unit will exercise 20 minutes before it is set.
Example: Set – Noon; Exercise – 11:40 a.m.



⚠ If you switch the Auto/Off/Manual switch is switched too soon, the engine may start. If engine does start, it will shut down automatically in about two (2) minutes.

- Set the generator's main circuit breaker to its ON (or closed) position.
- The generator is now programmed to start and exercise every seven days thereafter, on the day and at the time of day the switch was activated.
- Place a sign on the generator's control panel and on

the transfer switch that indicates the day and time the generator will be exercising.

NOTE:

If the battery terminals are disconnected or the control panel fuse is removed, the exercise timer needs to be reset for automatic exercise operation.

Figure 3.3 – "Set Exercise" Switch on Control Panel

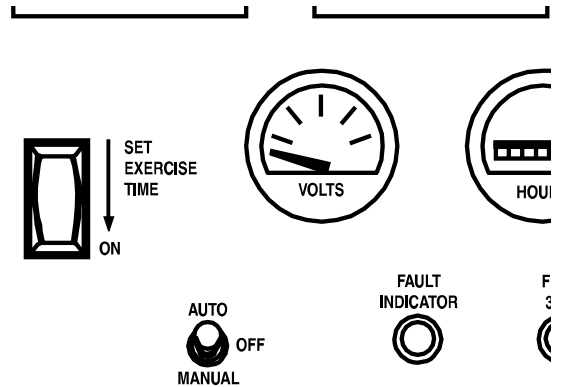

4.1 CHECKING THE ENGINE OIL LEVEL

For oil capacities, see "Specifications," Section 1.7.2, Page 6. For engine oil recommendations, see Section 4.2.1. To check the engine oil level, proceed as follows (Figure 4.1):

1. Remove the dipstick and wipe it dry with a clean cloth.
2. Install the dipstick cap; then, remove it again. The oil level should be at the dipstick "Full" mark. If necessary, add oil to the "Full" mark only. **DO NOT FILL ABOVE THE "FULL" MARK.**
3. Install the dipstick.



⚠ **Never operate the engine with the oil level below the "Add" mark on the dipstick. Doing this could damage the engine.**

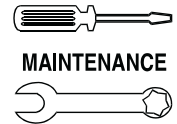

Figure 4.1 – Oil Dipstick and Fill

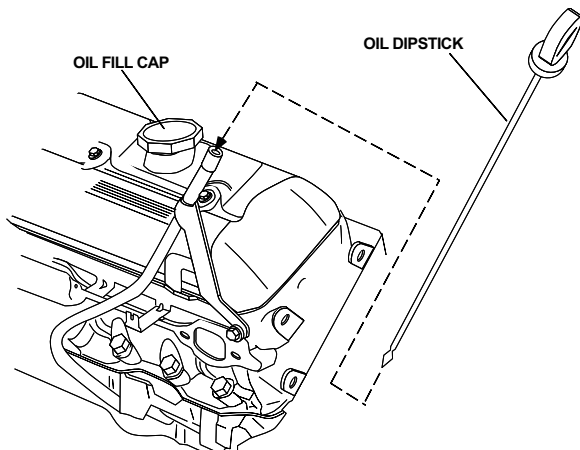
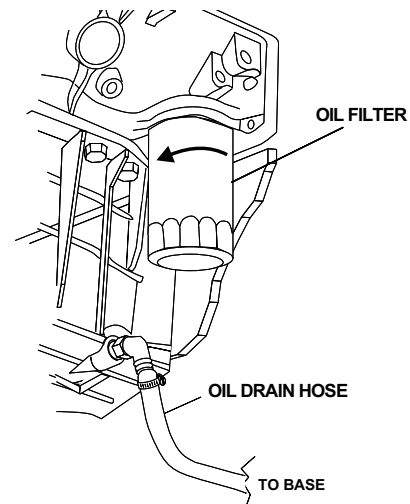

Figure 4.2 – Oil Filter



4.2 CHANGING THE ENGINE OIL AND FILTER

◆ 4.2.1 Engine Oil Recommendations

Use oil of API Service Class SG, SH or SJ. The recommended oil grade for the engine is SAE 15W-40.

NOTE:

The unit is supplied with “break-in” oil. See the “Service Schedule,” Section 4.12 (Page 19), for the first required oil change.

—▲ CAUTION ▲—

▲ Any attempt to crank or start the engine before it has been properly serviced with the recommended oil may result in an engine failure.

◆ 4.2.2 Oil and Filter Change Procedure

To change the oil and filter, proceed as follows:

Refer to the “Service Schedule,” (Section 4.12, Page 19) for engine oil and filter change frequencies.

Drain the oil while the engine is still warm from running. This means, warm up the engine, shut it down and drain it immediately as follows:

1. Remove the oil drain hose from its retaining clip, located on the generator base frame.
2. Loosen and remove the oil drain hose cap, located on the base frame end of the hose. Drain the oil completely into a suitable container.
3. When all of the oil has drained, install and tighten the oil drain hose cap.
4. Turn the oil filter (Generac part number 0A37970001, Figure 4.2) counterclockwise and remove it. Properly dispose of the old filter.

5. Apply a light coating of engine oil to the seal of new oil filter. Install the filter and tighten by hand only. **DO NOT OVERTIGHTEN.**
6. Remove the oil fill cap (Figure 4.1). Add the recommended oil (see Section 4.2.1). **DO NOT FILL ABOVE THE DIPSTICK “FULL” MARK.** Crankcase oil capacity is 4.5 U.S. quarts (4.25 L).

—▲ CAUTION ▲—

- ▲ After refilling the crankcase with oil, always check the oil level on the dipstick. Never operate the engine with the oil level below the “Add” mark on the dipstick. Doing this could damage the engine.
7. Start the engine and check for oil leaks.
 8. Check the oil level after checking for leaks to ensure that the oil is filled to the proper level.

4.3 CHANGING THE ENGINE AIR CLEANER

To replace the engine air cleaner, (Generac part number 0A4637, simply remove the air cleaner cover and replace the air filter making sure it is positioned properly before reattaching the cover. (See Figure 4.3, page 16)

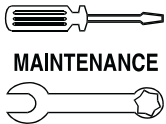
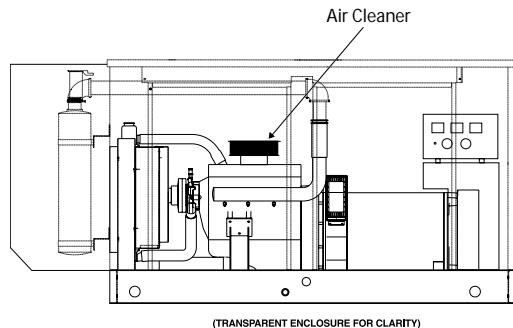

Figure 4.3 – Engine Air Cleaner



See the “Service Schedule,” Section 4.12, Page 19, for recommended air cleaner maintenance.

4.4 SPARK PLUGS

Reset the spark plug gap or replace the spark plugs as necessary. See Section 4.12, Page 19.

1. Clean the area around the base of the spark plugs to keep dirt and debris out of the engine. Clean the plugs by scraping using a wire brush. Do not “blast” the spark plugs to clean.
2. Remove the spark plugs and check the condition. Replace the spark plugs if worn or if reuse is questionable. See the “Service Schedule,” Section 4.12, Page 19, for recommended inspection.
3. Check the spark plug gap using a feeler gauge. Adjust the gap to 0.045 inch (1.1 mm) by carefully bending the ground electrode (Figure 4.4).

Figure 4.4 – Setting the Spark Plug Gap

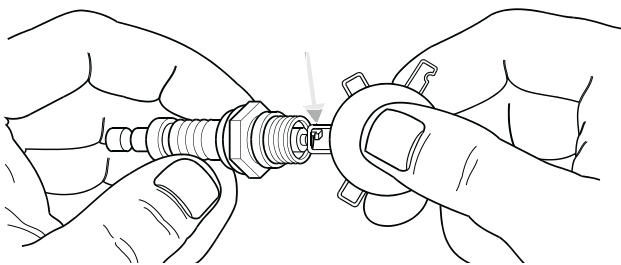

4.5 BATTERY MAINTENANCE

The battery should be inspected per the “Service Schedule,” Section 4.12, Page 19. The following procedure should be followed for inspection:

1. Inspect the battery posts and cables for tightness and corrosion. Tighten and clean as necessary.
2. Check the battery fluid level of unsealed batteries and, if necessary, fill with **DISTILLED WATER ONLY. DO NOT USE TAP WATER IN BATTERIES.**

3. Have the state of charge and condition checked. This should be done with an automotive-type battery hydrometer or load test.

⚠ Standby generators installed with automatic transfer switches will crank and start automatically when normal (utility) source voltage is removed or is below an acceptable preset level. To prevent such automatic start-up and possible injury to personnel, do not connect battery cables until the normal source voltage at the transfer switch is correct and the system is ready to be placed into operation.

⚠ Storage batteries give off explosive hydrogen gas. This gas can form an explosive mixture around the battery for several hours after charging. The slightest spark can ignite the gas and cause an explosion. Such an explosion can shatter the battery and cause blindness or other injury. Any area that houses a storage battery must be properly ventilated. Do not allow smoking, open flame, sparks or any spark producing tools or equipment near the battery.

⚠ Battery electrolyte fluid is an extremely caustic sulfuric acid solution that can cause severe burns. Do not permit fluid to contact eyes, skin, clothing, painted surfaces, etc. Wear protective goggles, protective clothing and gloves when handling a battery. If fluid is spilled, flush the affected area immediately with clear water.

⚠ WARNING ⚠

⚠ Do not dispose of the battery in a fire. The battery is capable of exploding.

⚠ Do not open or mutilate the battery. Released electrolyte can be toxic and harmful to the skin and eyes.

⚠ The battery represents a risk of high short circuit current. When working on the battery, always remove watches, rings or other metal objects, and only use tools that have insulated handles.

► Battery replacement

Generac uses a Group 27F vented type battery that has 600 CCA @ 0° F. Generac's part number is 058665.

Note:

The BCI number should be located directly on the battery.

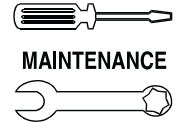

4.6 COOLING SYSTEM

Air intake and outlet openings in the generator compartment must be open and unobstructed for continued proper operation. This includes such obstructions as high grass, weeds, brush, leaves and snow.

Without sufficient cooling and ventilating air flow, the engine/generator quickly overheats, which causes it to shut down.

⚠ WARNING ⚠

⚠ The exhaust system of this product gets extremely hot and remains hot after shutdown. High grass, weeds, brush, leaves, etc. must remain clear of the exhaust. Such materials may ignite and burn from the heat of the exhaust system.

4.7 OVERLOAD PROTECTION FOR ENGINE DC ELECTRICAL SYSTEM

Engine cranking, start-up and running are controlled by a solid-state engine controller circuit board. Battery voltage is delivered to that circuit board via a 15-amp fuse. These overcurrent protection devices will open if the circuit is overloaded.

⚠ CAUTION ⚠

⚠ If a circuit breaker opens or a fuse element melts, you should find the cause of the overload before resetting the circuit breaker or replacing the fuse.

4.8 DC FUSE

The generator panel's 15-amp AGC fuse (Figure 4.4) protects the DC control circuit against overload. The fuse is wired in series with the battery output lead to the panel. If the fuse element has melted open, cranking or starting the engine cannot occur. Replace the fuse using only an identical 15-amp AGC replacement.

Figure 4.4 – Location of 15-amp Fuse

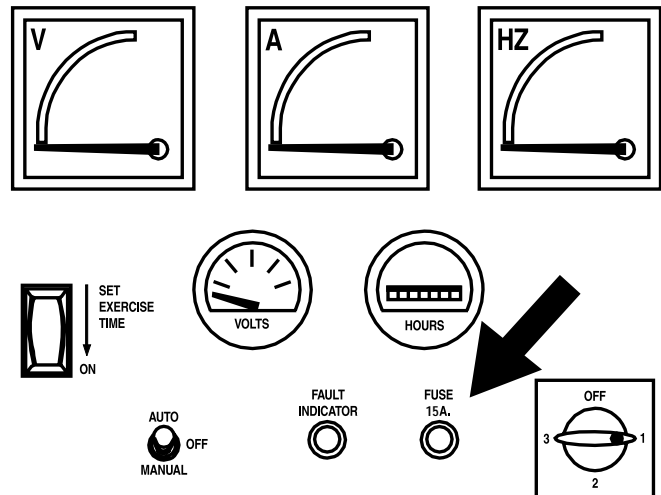

4.9 ENGINE COOLANT

Check the coolant level in the coolant recovery bottle.

- Add the recommended coolant mixture as necessary. See Section 1.10 on Page 7.
- Periodically remove the radiator pressure cap to make sure the coolant recovery system is functioning properly. Coolant should be at the bottom of the radiator filler neck. If the coolant level is low, inspect the gasket in the radiator pressure cap. Replace the cap, if necessary. To have the pressure cap tested, contact a Generac/Guardian Authorized Dealer. Inspect the cooling system and coolant recovery system for leaks.

4.10 MISCELLANEOUS MAINTENANCE

◆ 4.10.1 Cleaning the Generator

Keep the generator as clean and as dry as possible. Dirt and moisture that accumulate on internal generator windings have an adverse effect on insulation resistance.

Periodically, clean the generator's exterior surfaces. A soft brush may be used to loosen caked on dirt. Use a vacuum system or dry, low pressure air to remove any accumulations of dirt. The generator is housed inside an all-weather enclosure; clean the enclosure with a soft, damp cloth or sponge and water.

Once each year, have the generator cleaned and inspected by a Generac/Guardian Authorized Dealer. Service technicians will use dry, low pressure air to clean internal windings. Parts inside the control console should be cleaned and inspected at this time as well.

Finally, have the insulation resistance of stator and rotor windings checked. If insulation resistances are excessively low, the generator may require drying.

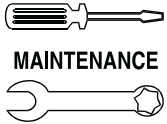

◆ 4.10.2 Rodent Protection

The intrusion of rodents into the generator set can cause a wide range of problems, from failure of the unit to start, to personal injury and, in extreme circumstances, short circuit or fire. Although the unit was designed to limit this problem, further precautions can be taken by the owner to help minimize both the chance of rodent entry and the extent of any damage. The following inspection should be performed.

1. The base frame of the unit contains an optional fuel inlet location and four lifting holes that are capped at the factory. These caps are sometimes removed for transportation during installation but always should be replaced afterwards. Check that they are secured in place. The same applies for any access ports in the roof of the enclosure. If any of these caps are missing, contact a Generac/Guardian Authorized Dealer.
2. Inside the generator set, the chance of rodent entry into the control panel is greatly reduced by the inclusion of adjustable wire connectors. Check that the wire connector screws are tight, thus closing off any gap between the access holes and the wires.

4.11 OUT OF SERVICE PROCEDURE

◆ 4.11.1 Removal From Service

If the generator cannot exercise every seven days, and it is to be out of service longer than 90 days, prepare the generator for storage as follows:

1. Start the engine and let it warm up.
2. Close the fuel shutoff valve in the fuel supply line and allow the unit to shut down.
3. Once the unit has shut down, it will signal a fault on the control panel.
4. Set the Auto/Off/Manual switch to OFF and turn off the utility power to the transfer switch.
5. While the engine is still warm from running, drain the oil completely. Refill the crankcase with SAE 15W-40 oil having API Service Class SG, SH or SJ.

6. Attach a tag to the engine indicating the viscosity and classification of the oil in the crankcase.
7. Remove the spark plug(s) and spray fogging agent into the spark plug(s) threaded openings. Reinstall and tighten the spark plug(s).
8. Remove the battery and store it in a cool, dry room on a wooden board. Never store the battery on any concrete or earthen floor.
9. Clean and wipe the entire generator.

◆ 4.11.2 Return To Service

To return the unit to service after storage, proceed as follows:

1. Verify that utility power is turned off to the transfer switch and that the Auto/Off/Manual switch is set to OFF.
2. Check the tag on the engine for oil viscosity and classification. Verify that the correct recommended oil is used in engine. See Section 4.2.1 (Page 14). If necessary, drain and refill with the proper oil.
3. Check the battery. Fill all cells to the proper level with distilled water. **DO NOT USE TAP WATER IN THE BATTERY.** Remove the battery before charging. Recharge the battery to 100 percent state of charge, or, if defective, replace the battery with a 12-volt DC Group 27F battery rated for 90 amp hours (part # 058665).
4. Clean and wipe the entire generator.
5. Reconnect the battery. Observe battery polarity. Damage may occur if the battery is connected incorrectly.
6. Open the fuel shutoff valve.
7. Start the unit by moving the Auto/Off/Manual switch to MANUAL. Allow the unit to warm up thoroughly.
8. Stop the unit and set the Auto/Off/Manual switch to AUTO.
9. Turn on the utility power to the transfer switch.
10. The generator is now ready for service.

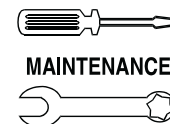

4.12 SERVICE SCHEDULE

ATTENTION: It is recommended that all service work be performed by your nearest Generac/Guardian Authorized Dealer.

SYSTEM/COMPONENT	PROCEDURE			FREQUENCY
	Inspect	Change	Clean	
X = Action R = Replace/Adjust as Needed * = Notify Dealer if Repair is Needed.				W = Weekly M = Monthly Y = Yearly H = Hours
FUEL				
Fuel lines and connections*	X			EVERY 3 M
LUBRICATION				
Oil level	X			M
Oil		X		FIRST 9 H, EVERY 150 H / 6 M
Oil filter		X		FIRST 9 H, EVERY 150 H / 6 M
Oil line leakage*	X			100 H
COOLING				
Engine cooling system*	X			M
Coolant		X		Y
Enclosure louvers	X		X	W
EXHAUST				
Exhaust system	X			EVERY 3 M
Retorque Exhaust Manifold*	X			FIRST 100 H AND EVERY 800 H
BATTERY				
Charge and condition	X	R	X	EVERY 3 M
FAN BELT				
Tension and condition*	X	R		EVERY 3 M
ENGINE				
Retorque cylinder head*	X			FIRST 100 H AND EVERY 800 H
Retorque intake manifold*	X			FIRST 100 H AND EVERY 800 H
Starter motor*	X	R		EVERY 500 H
DC alternator*	X	R		EVERY 500 H AND Y
Air cleaner*	X	R		EVERY 500 H
Compression*	X			EVERY 800 H
Valve clearance*	X	R		EVERY 800 H
Governor*	X	R		Y
Safety devices*	X	R		EVERY 6 M
Spark plugs	X	R		500 H AND Y
Ignition system*	X	R		EVERY 3 M
GENERAL				
Overall condition	X		X	M
Exercise system				W
COMPLETE TUNE-UP*	TO BE COMPLETED BY A GENERAC/ GUARDIAN AUTHORIZED DEALER			Y



5.1 TROUBLESHOOTING GUIDE

PROBLEM	CAUSE	CORRECTION
The engine will not crank.	<ol style="list-style-type: none"> 1. Fuse blown 2. Loose, corroded or defective battery cables 3. Defective starter contactor 4. Defective starter motor 5. Dead Battery 	<ol style="list-style-type: none"> 1. Replace fuse. 2. Tighten, clean or replace as necessary. 3. * 4. * 5. Charge or replace battery.
The engine cranks but will not start.	<ol style="list-style-type: none"> 1. Out of fuel 2. Defective fuel solenoid (FS) 3. Open #14 wire from engine control board 4. Defective spark plug(s) 5. Dirty/Blocked air filter 	<ol style="list-style-type: none"> 1. Replenish fuel. 2. * 3. * 4. Clean, re-gap or replace plug(s). 5. Clean or replace as required.
The engine starts hard and runs rough.	<ol style="list-style-type: none"> 1. Air cleaner plugged or damaged 2. Defective spark plug(s) 3. Dirty/Blocked air filter 	<ol style="list-style-type: none"> 1. Check, clean or replace air cleaner. 2. Clean, re-gap or replace plug(s). 3. Clean or replace as required.
The engine starts, but then shuts down.	<ol style="list-style-type: none"> 1. Engine oil level low 2. Defective low oil pressure switch 3. Defective high temperature switch 4. Defective control board 5. Low coolant level 	<ol style="list-style-type: none"> 1. Check oil and add oil as needed. 2. * 3. * 4. * 5. Check coolant level, repair leaks and refill.
The Auto/Off/Manual switch is set to OFF, but the engine continues to run.	<ol style="list-style-type: none"> 1. Defective switch 2. Defective control board 	<ol style="list-style-type: none"> 1. * 2. *
There is no AC output from the generator.	<ol style="list-style-type: none"> 1. Generator main line circuit breaker open 2. Generator internal failure 	<ol style="list-style-type: none"> 1. Reset circuit breaker to ON (or closed). 2. *
There is no transfer to standby after utility source failure.	<ol style="list-style-type: none"> 1. Generator main line circuit breaker open 2. Defective transfer switch coil 3. Defective transfer relay 4. Transfer relay circuit open 5. Defective control logic board 	<ol style="list-style-type: none"> 1. Reset circuit breaker to ON (or closed). 2. * 3. * 4. * 5. *

***Contact your nearest Generac/Guardian Authorized Dealer for assistance.**

Section 6 – Electrical Data

(Model No. 004373-1) Guardian Liquid-cooled 40 kW Generator Electrical Schematic (Control Panel) – Drawing No. 0D4993-A

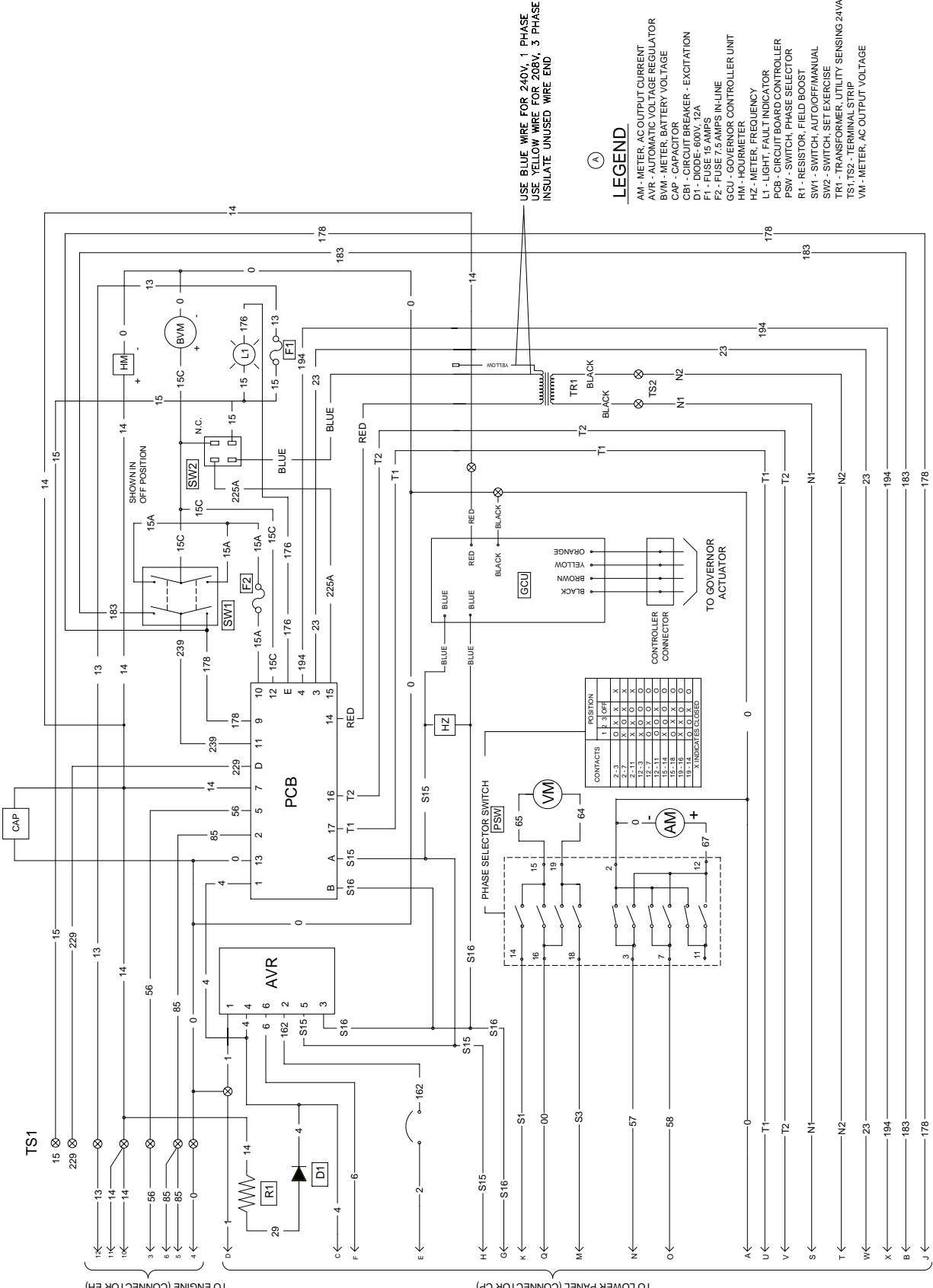
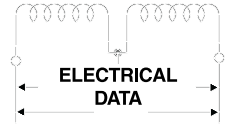

USE BLUE WIRE FOR 240V, 1 PHASE
USE YELLOW WIRE FOR 208V, 3 PHASE
INSULATE UNUSED WIRE END

(A) LEGEND

- AM - METER, AC OUTPUT CURRENT
- AVR - AUTOMATIC VOLTAGE REGULATOR
- BVM - METER, BATTERY VOLTAGE
- CAP - CAPACITOR
- D1 - DIODE, 100V, 1A
- DB1 - CIRCUIT BREAKER - EXCITATION
- DB2 - CIRCUIT BREAKER - 24V
- F1 - FUSE 15 AMPS
- F2 - FUSE 7.5 AMPS IN-LINE
- GCU - GOVERNOR CONTROLLER UNIT
- HM - HOURMETER
- HZ - METER, FREQUENCY
- L1 - LIGHT, FAULT INDICATOR
- PCB - CIRCUIT BOARD CONTROLLER
- PSW - SWITCH, PHASE SELECTOR
- R1 - RESISTOR, FIELD BOOST
- SW1 - SWITCH, AUTO/OFF/MANUAL
- SW2 - SWITCH, SET EXERCISE
- TR1 - TRANSFORMER, UTILITY SENSING 24VA
- TS1, TS2 - TERMINAL STRIP
- VM - METER, AC OUTPUT VOLTAGE

CONTACTS	POSITION		
	1	2	3
2-3	X	X	X
2-11	X	X	X
12-3	X	O	O
12-11	O	O	O
15-14	X	O	O
15-16	X	O	O
19-14	O	O	O
19-16	O	O	O

UNBROUGHT TO ATTENTION

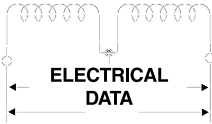

Section 6 – Electrical Data

(Model No. 004373-1) Guardian Liquid-cooled 40 kW Generator Wiring Diagram (Control Panel) – Drawing No. OD4992-A

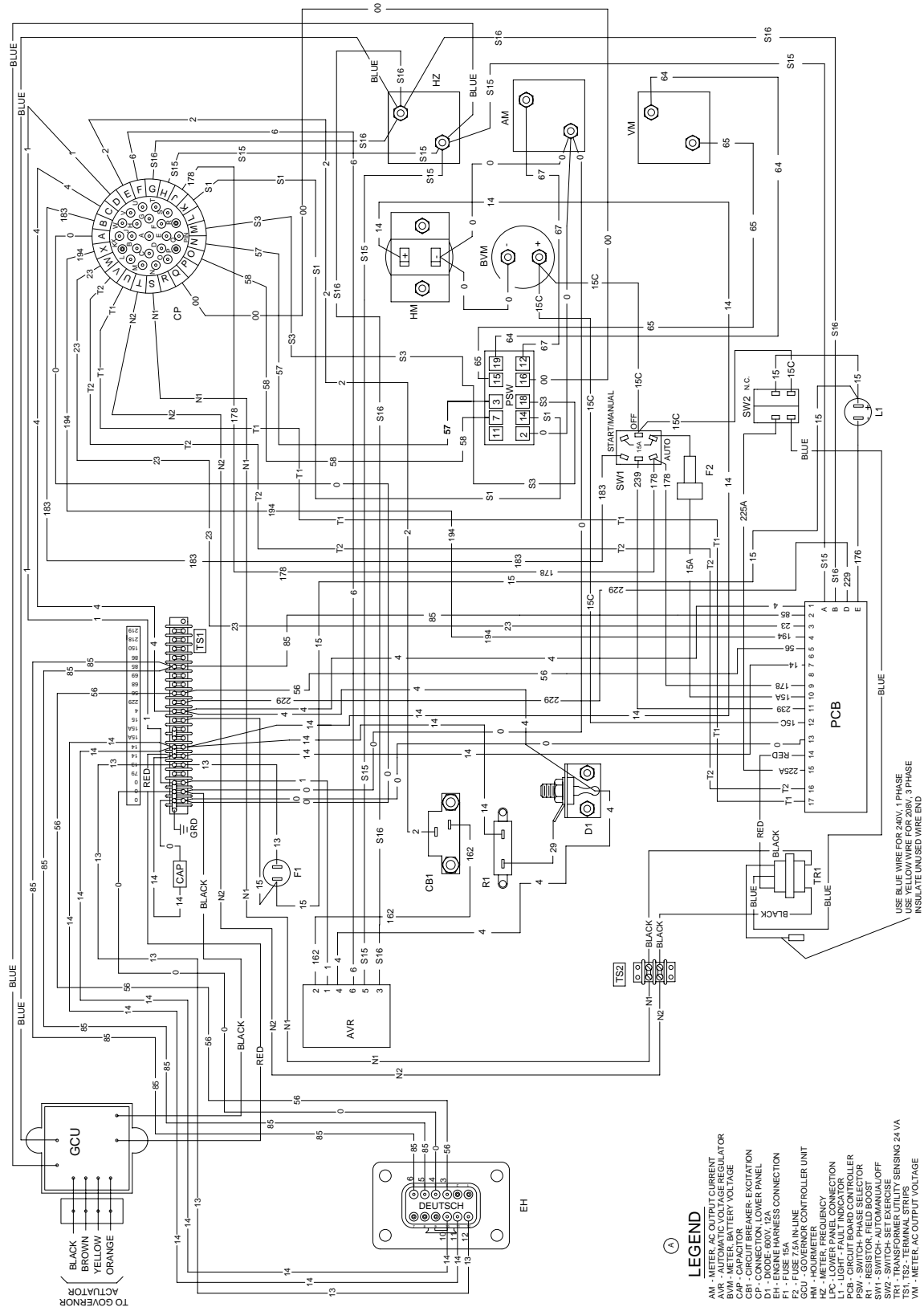

- LEGEND**
- AM - METER, AMPERES
 - AVR - AUTOMATIC VOLTAGE REGULATOR
 - BVA - METER, BATTERY VOLTAGE
 - CAP - CAPACITOR
 - DEL - DELTA CONNECTION
 - CP - CONNECTION, LOWER PANEL
 - D1 - DIODE, 600V, 12A
 - EH - ENGINE HARNESS CONNECTION
 - F - FUSE
 - F2 - FUSE, 7.5A IN-LINE
 - GCU - GOVERNOR CONTROL UNIT
 - HZ - METER, FREQUENCY
 - LPC - LOWER PANEL CONNECTION
 - LIGHT - LIGHT, FAULT INDICATOR
 - PCB - CONTROL BOARD
 - PSW - SWITCH, PHASE SELECTOR
 - R1 - RESISTOR, FIELD BOOST
 - SW - SWITCH, ON-OFF
 - SW2 - SWITCH, SET EXERCISE
 - TR1 - TRANSFORMER, UTILITY SENSING 24 VA
 - TS1, TS2 - TERMINAL STRIPS
 - VM - METER, AC OUTPUT VOLTAGE

Section 6 – Electrical Data

(Model No. 004626-0) Guardian Liquid-cooled 40 kW Generator Schematic (Control Panel) – Drawing No. 0D6975

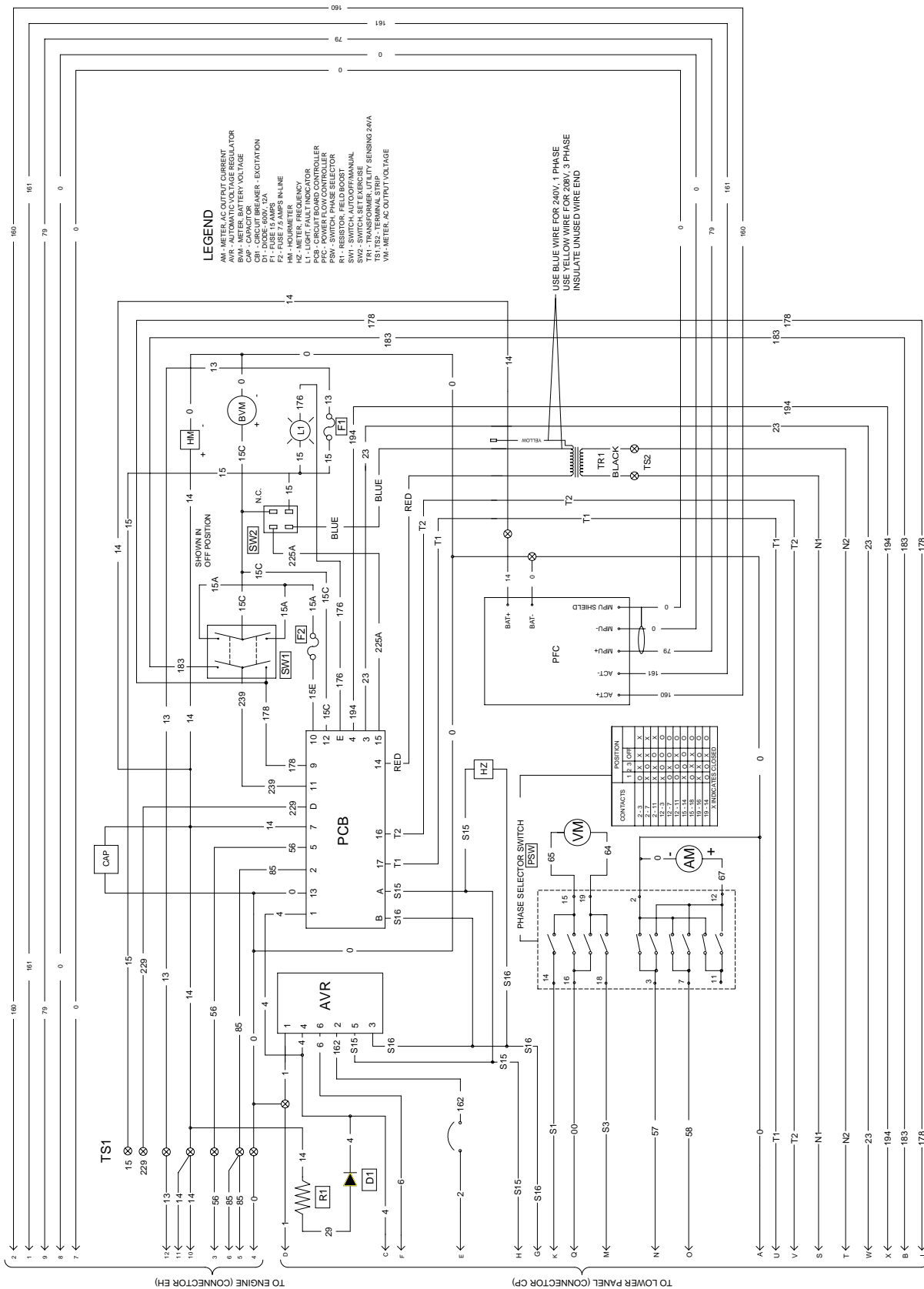
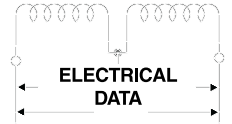

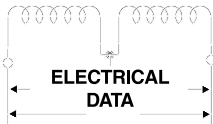

Section 6 – Electrical Data

**(Model No. 004626-0) Guardian Liquid-cooled 40 kW Generator
Wiring Diagram (Control Panel) – Drawing No. OD6974**

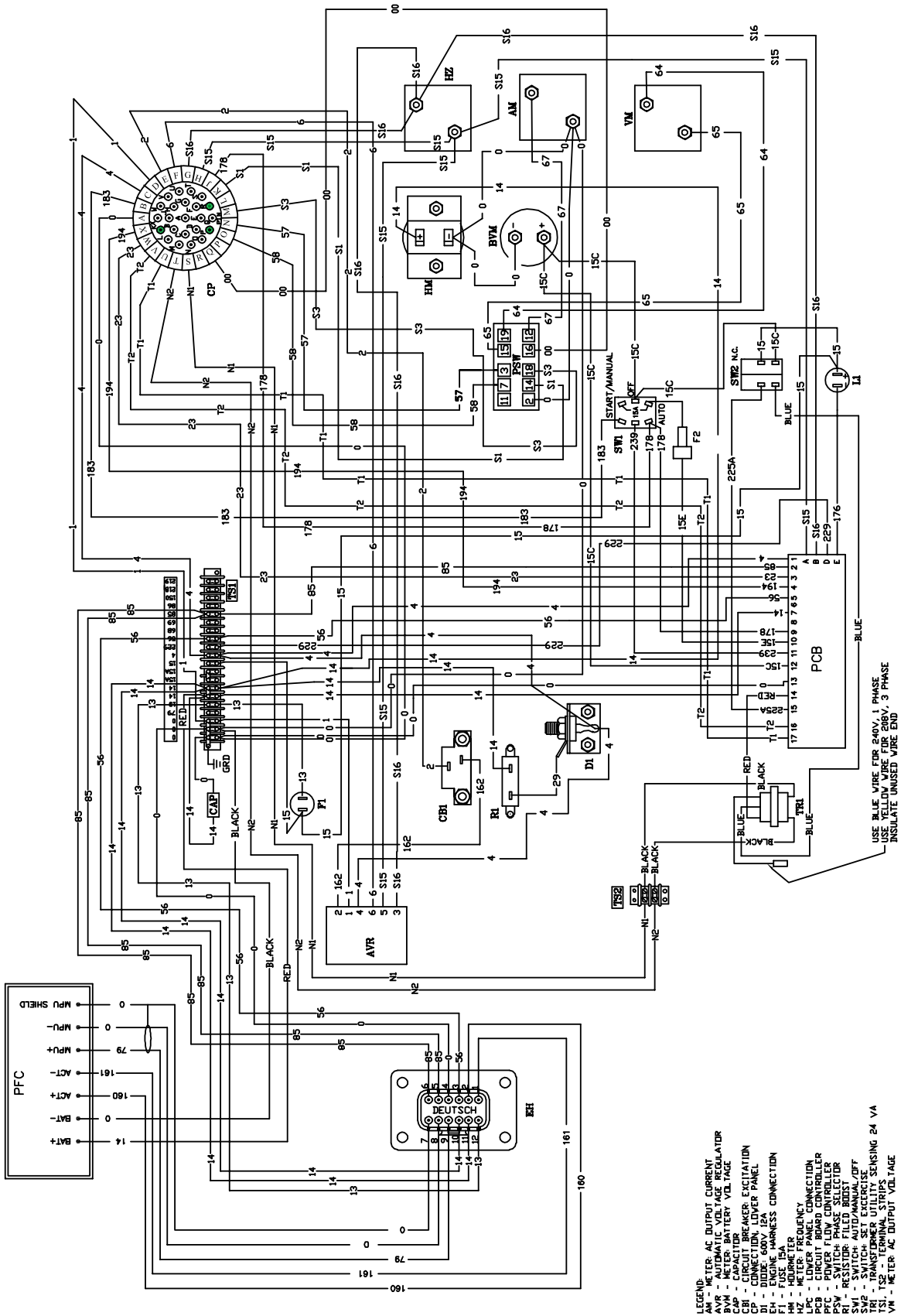

LEGEND:
 AM - METER, AC OUTPUT CURRENT
 AVR - AUTOMATIC VOLTAGE REGULATOR
 BVM - METER, BATTERY VOLTAGE
 CB - CIRCUIT BREAKER, EXCITATION
 CP - CONNECTION, LOWER PANEL
 DI - DIODE, 600V 12A
 F1 - FUSE, 15A
 F2 - FUSE, 15A
 FV - HOURMETER
 HM - METER, FREQUENCY
 NEZ - METER, CONNECTION
 PCB - POWER FLOW CONTROLLER
 PFC - POWER FACTOR CORRECTOR
 PSW - RESISTOR, FINE SELECTOR
 SW1 - SWITCH, AUTO/MANUAL/OFF
 SW2 - SWITCH, SET EXERCISE
 TS1 - TEST TERMINAL, STARTING
 TS2 - TEST TERMINAL, STOPPING
 VM - METER, AC OUTPUT VOLTAGE

USE BLUE WIRE FOR 240V, 1 PHASE
 INSULATE UNUSED WIRE END

Section 6 – Electrical Data

(Model Nos. 004373-1 & 004262-0) Guardian Liquid-cooled 40 kW Generator Electrical Schematic – Engine (4.3L) – Drawing No. 0A4592-B

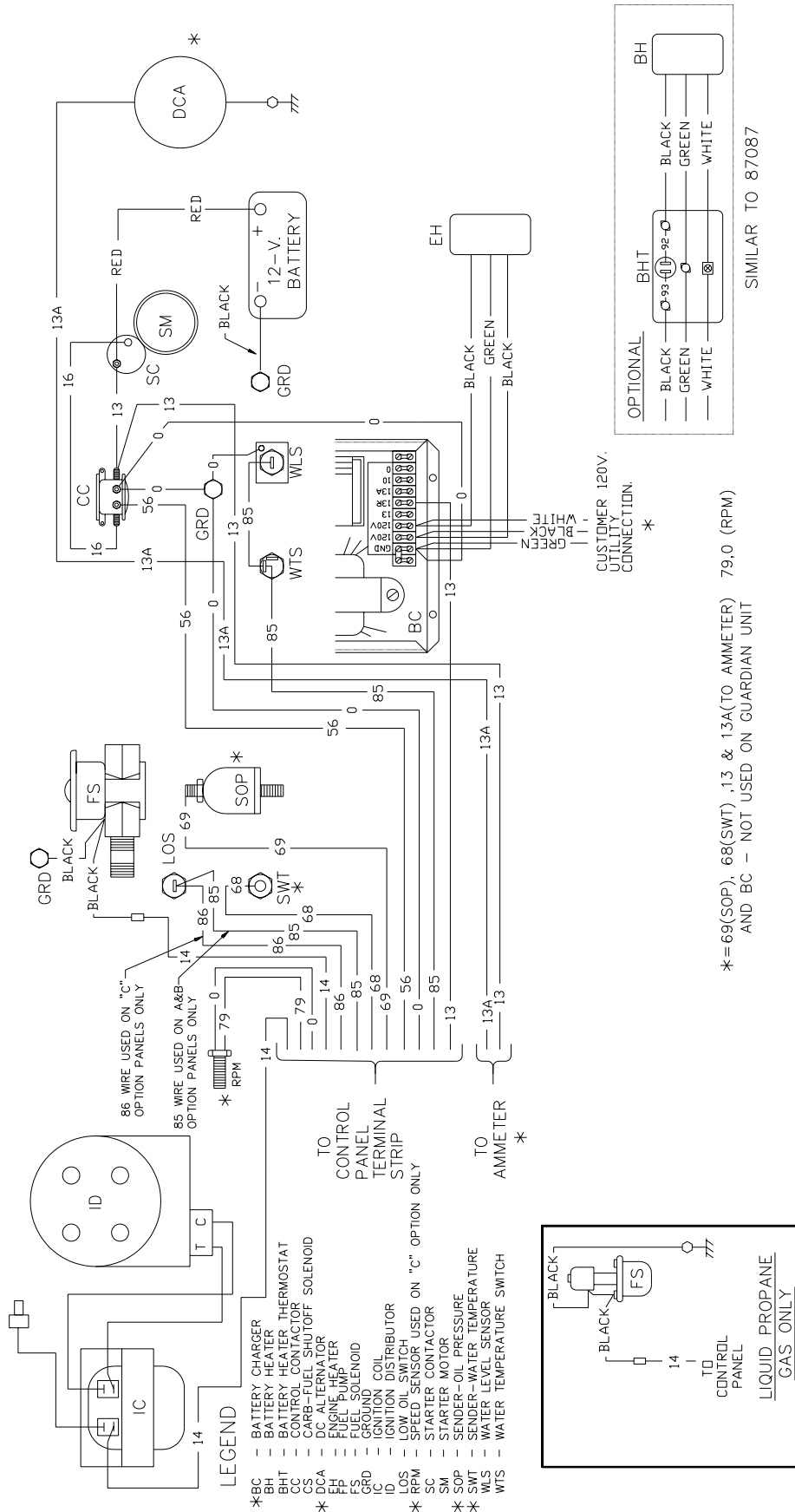
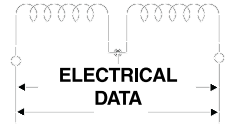

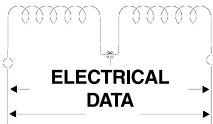

Section 6 – Electrical Data

(Model Nos. 004373-1 & 004262-0) Guardian Liquid-cooled 40 kW Generator Wiring Diagram – Engine (4.3L) – Drawing No. 0A4591-B

LEGEND

* BC - BATTERY CHARGER	EH - ENGINE HEATER	LDS - LOW OIL SWITCH
BH - BATTERY HEATER	FS - FUEL SHUTOFF SOLENOID	* RPM - SPEED SENSOR USED ON 'C' OPTION ONLY
BHT - BATT. HEAT. THERMOSTAT	FP - FUEL PUMP	SC - STARTER CONTACTOR
CC - CONTROL CONTACTOR	G - GROUND	SM - STARTER MOTOR
CS - CARB FUEL SHUTOFF SOLENOID	IC - IGNITION COIL	* SOP - SENDER-OIL PRESSURE
DCA - DC ALTERNATOR	ID - IGNITION DISTRIBUTOR	* SWT - SENDER-WATER TEMP.
		WLS - WATER LEVEL SENSOR
		WTS - WATER TEMPERATURE SWITCH

* 69(SOP), 68(SWT), 13 & 13A(TO AMMETER) 79.0 (RPM)
AND BC - NOT USED ON GUARDIAN UNIT

* 85 WIRE USED ON A&B OPTION PANELS ONLY
86 WIRE USED ON "C" OPTION PANELS ONLY

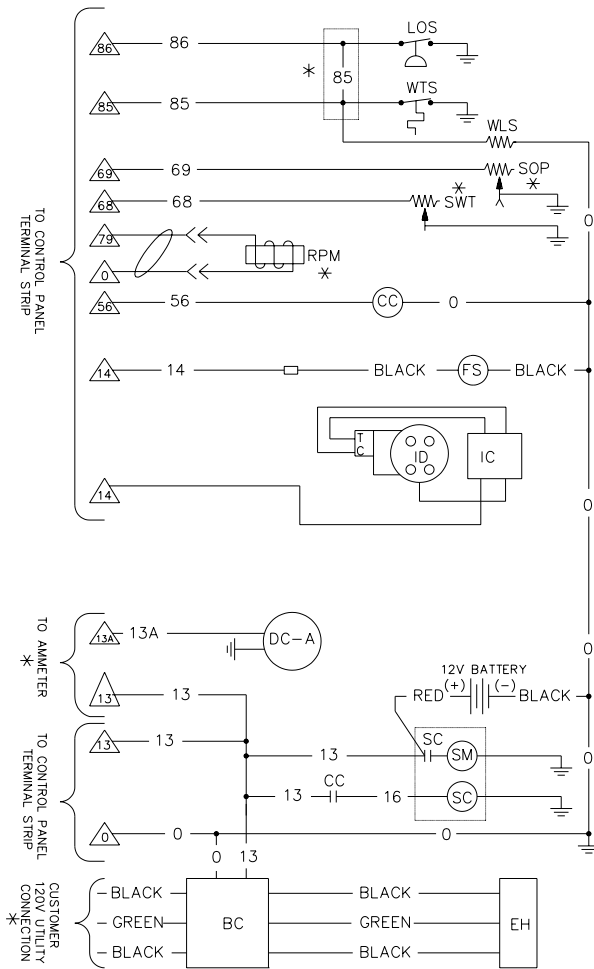

SIMILAR TO 87086

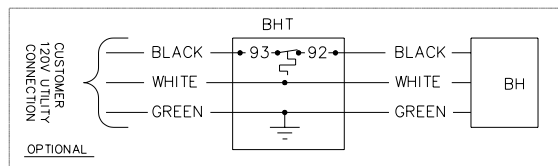

Section 6 – Electrical Data

(Model No. 004373-1) Guardian Liquid-cooled 40 kW Generator
Electrical Schematic – Stepper Motor – Drawing No. 0A5858

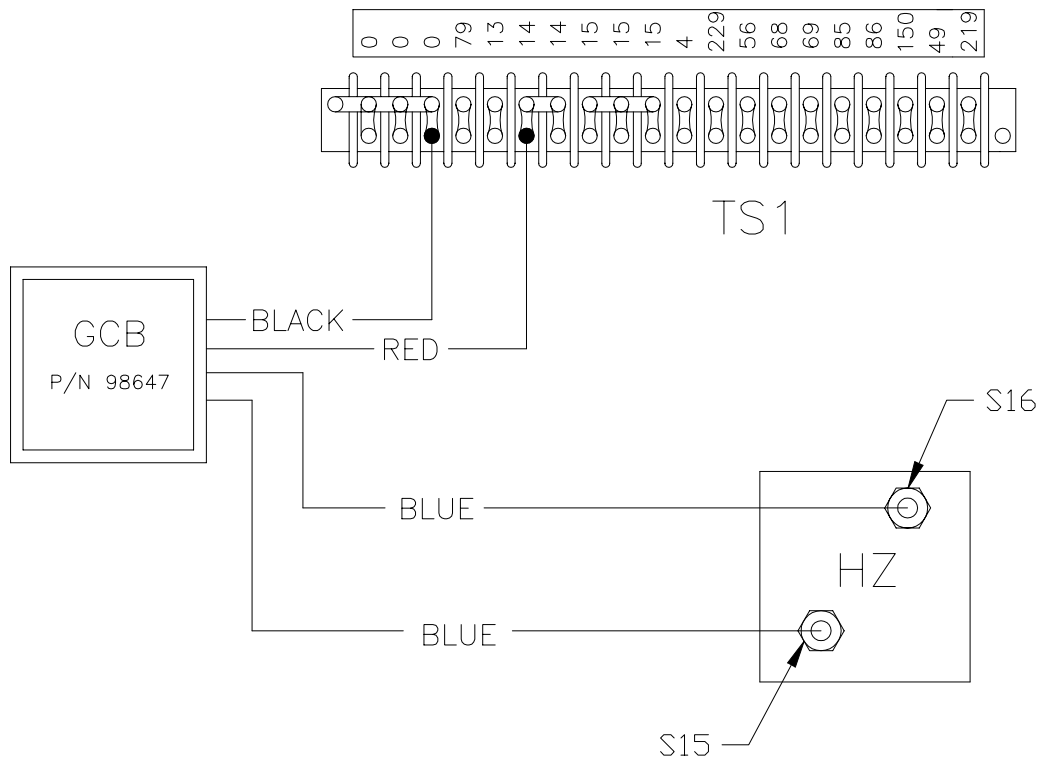
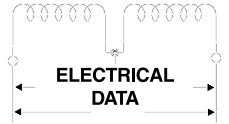

LEGEND

- GCB – GOVERNOR CONTROL BOARD
- HZ – FREQUENCY METER
- TB1 – TERMINAL BLOCKS

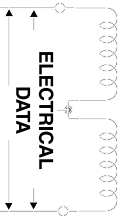

Section 6 — Electrical Data
 (Model Nos. 004373-1 & 004262-0) Guardian Liquid-cooled 40 kW Generators
 Wiring Diagram - Lower Panel - Drawing No. 0D5997

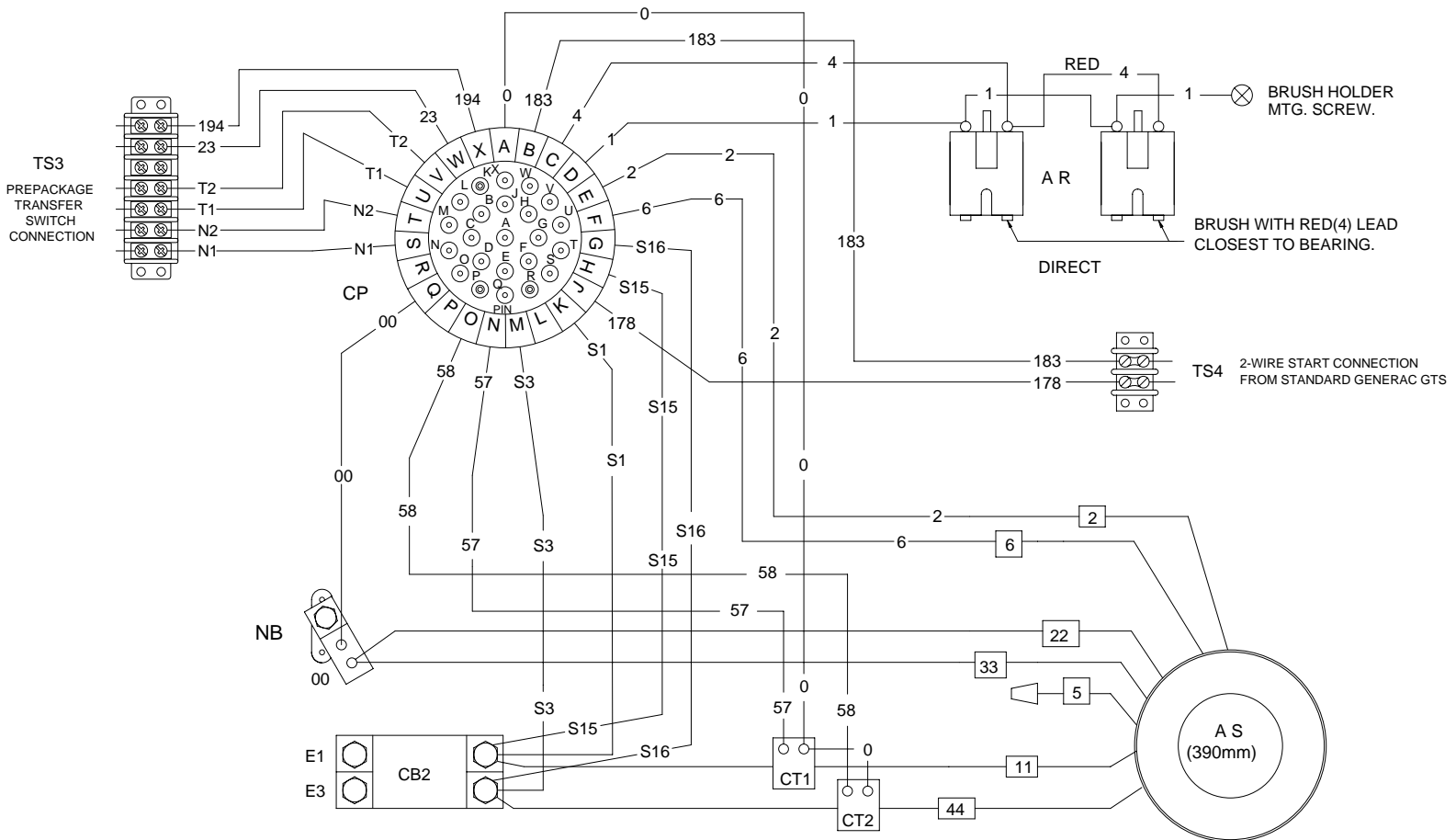

E1 TO E3 240V.
 E1 TO 00 120V.
 E3 TO 00 120V.

CUSTOMER CONNECTION
 120/240V. 1-PHASE

- LEGEND**
- AR = ALTERNATOR ROTOR
 - AS = ALTERNATOR STATOR
 - CB2 = CIRCUIT BREAKER - MAIN
 - CP = CONTROL PANEL CONNECTOR LOWER PANEL
 - CT1 & CT2 = CURRENT TRANSFORMER
 - DPE = EXCITATION WINDING
 - NB = NEUTRAL BLOCK
 - TP = THERMAL PROTECTOR
 - TS3 = TERMINAL STRIP, PRE-PACKAGED TRANSFER SWITCH CONNECTION
 - TS4 = TERMINAL STRIP, 2-WIRE START CONNECTION

Section 6 – Electrical Data

(Model Nos. 004373-1 & 004262-0) Guardian Liquid-cooled 40 kW Generators

Electrical Schematic - Lower Panel - Drawing No. 0D5997

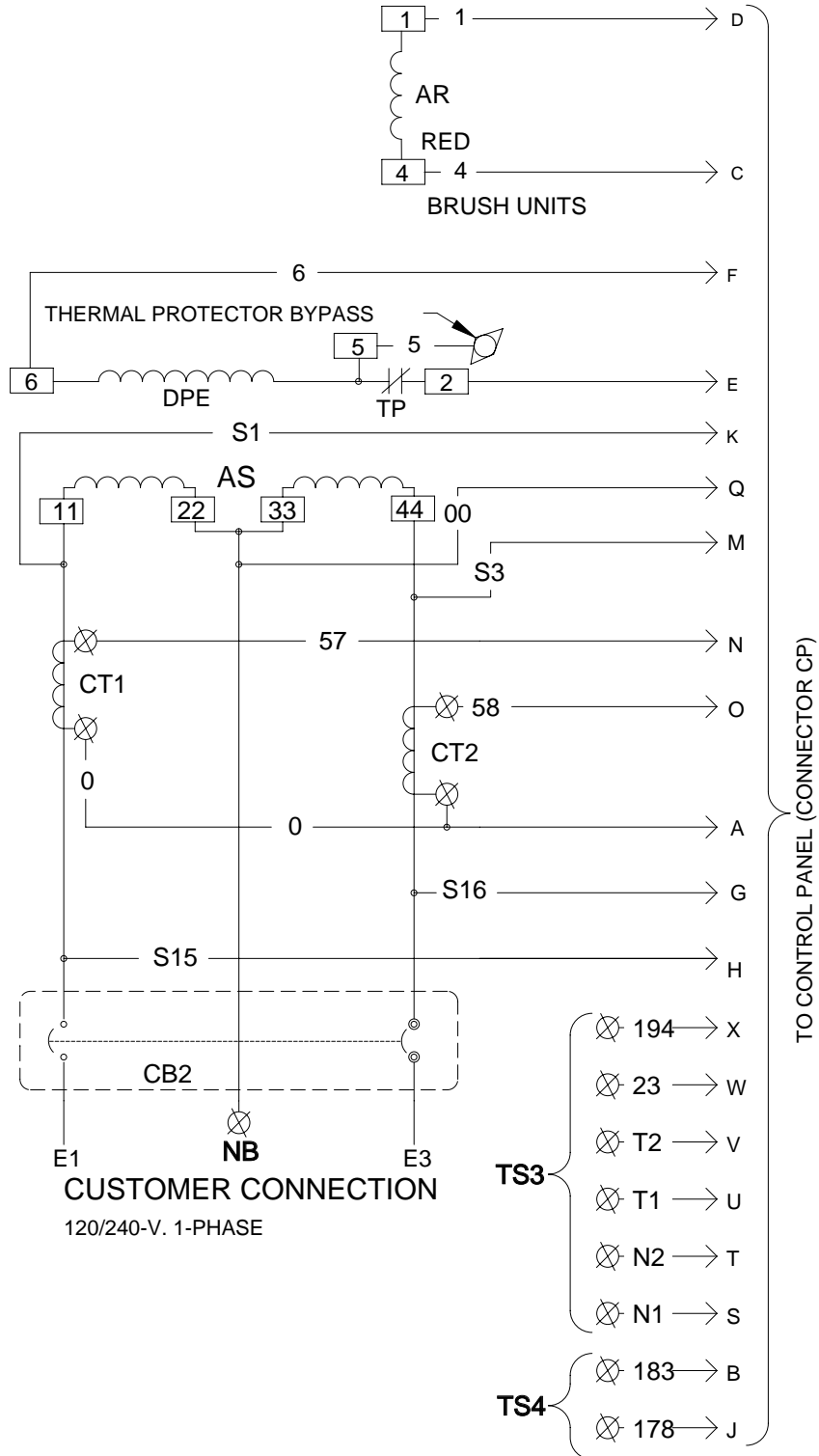
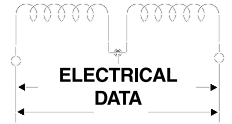



Section 7 — Exploded Views and Parts Lists

(Model No. 004373-1) Guardian Liquid-cooled 40 kW Generators

Control Panel - Drawing No. 0D4995-C

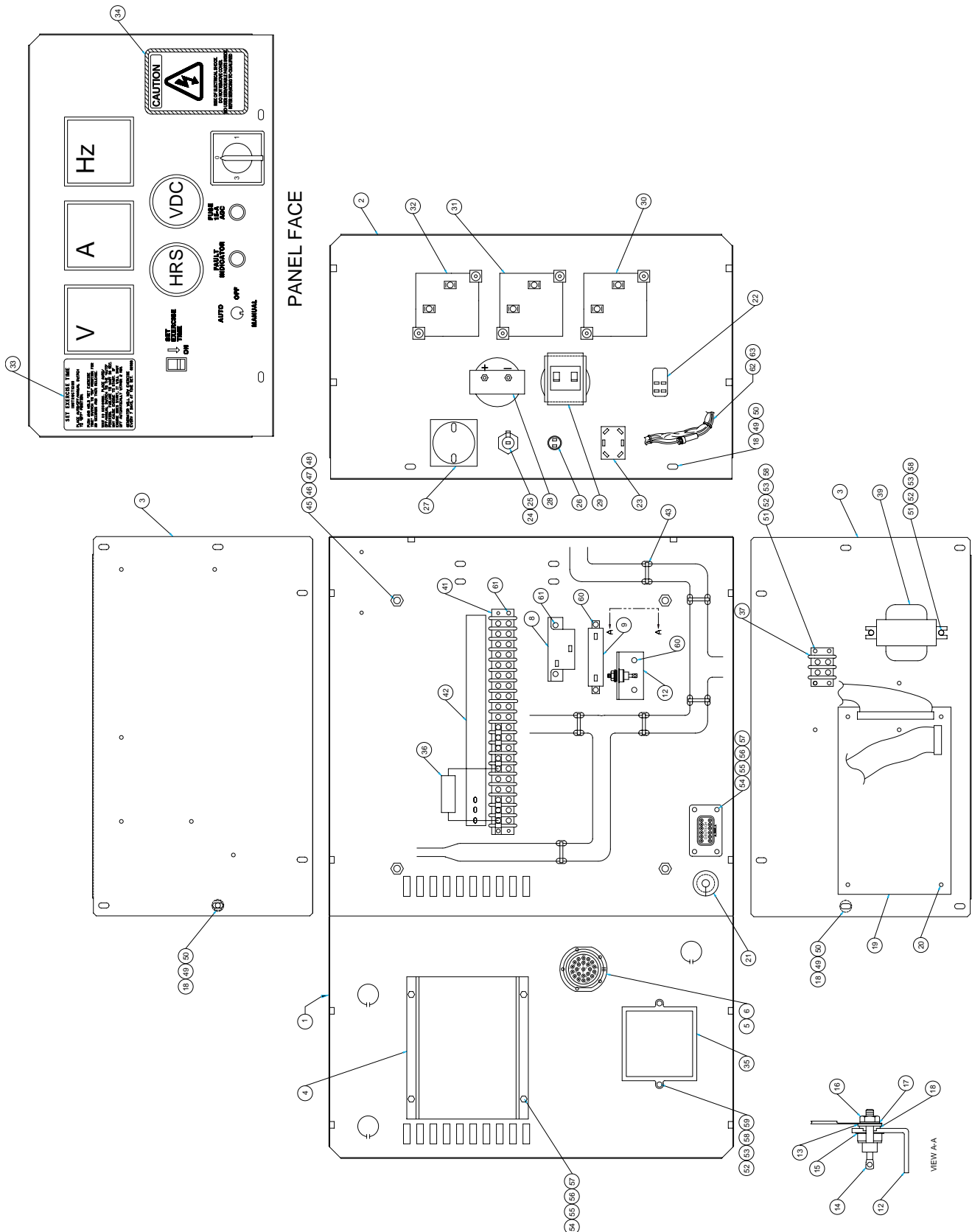

Section 7 — Exploded Views and Parts Lists
(Model No. 004373-1) Guardian Liquid-cooled 40 kW Generators
Control Panel - Drawing No. OD4995-C

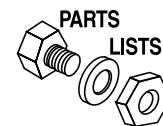

ITEM	PART NO.	QTY.	DESCRIPTION	ITEM	PART NO.	QTY.	DESCRIPTION
1	0D1523	1	PANEL BTM & BACK CONTROL PANEL	32	070042	1	FREQUENCY METER 240V 55-65HZ
2	0D1521A	1	CONTROL PANEL, FRONT W/ SILK SCREEN	33	081988	1	DECAL EXERCISE INFO
3	0D1522	2	PANEL,SIDE COVER CONTROL PANEL	34	0C1229	1	DECAL CUST CONN BOX
4	067680	1	ASSY VOLTAGE REGULATOR 60HZ	35	098647	1	ASSY L.C. ELECT GOV
5	0C8243	1	WASHER LOCK HDP DEUTSCH	36	0A3968	1	CAPACITOR FILTER ASY
6	0C8244	1	NUT, HDP DEUTSCH	37	048766	REF	BLOCK TERM 20A 2 X 6 X 1100V
8	048467	1	CIRCT BRK 7 X 1 ETA 46-500-P	39	083264	1	TFMR ASM,CMA 240/12V
9	057907	1	RES WW LUG 10R 10% 25W	41	057335	REF	BLOCK TERM 20A 20 X 6 X 1100V
10	064008	1	COVER CON PNL TOP (NOT SHOWN)	42	076061	1	DECAL, TERM. STRIP
12	055444	1	HEATSINK	43	029333	6	TIE WRAP 7.4" X .19" NATL UL
13	030468	1	WASHER STEP NYLON .20	45	040479	4	VIB MNT 1.0 X 1.0 X 1/4-20
14	049939	1	RECTIFIER MSC 12A 600V 1N1206R	46	022507	4	SCREW HHC 1/4-20 X 1/2 G5
15	070370	1	WASHER MICA .203	47	022127	4	NUT HEX 1/4-20 STEEL
16	022158	1	NUT HEX #10-32 STEEL	48	022097	4	WASHER LOCK M6-1/4
17	023762	1	WASHER SHAKEPROOF EXT #10 STL	49	033121	14	SCREW HHC #10-32 X 1/2
18	023897	15	WASHER FLAT #10 ZINC	50	022152	14	WASHER LOCK #10
19	076009A	1	PP LOGIC ASM 50/60HZ	51	036902	4	SCREW PPHM #6-32 X 1/2
20	040213	4	PCB SUPPORT SNAP-IN 1/4"	52	022155	6	WASHER LOCK #6
21	027744	1	GROMMET 3/4 X 5/32 X 5/16	53	022985	8	WASHER FLAT #6 ZINC
22	082573	1	SWITCH ROCKER DPST 125V SPD	54	036918	8	SCREW PPHM #8-32 X 1/2
23	076020	1	SWITCH TOG DPDT 15/10 SP	55	022264	8	WASHER LOCK #8-M4
24	032300	1	HOLDER FUSE	56	038150	8	WASHER FLAT #8 ZINC
25	022676	1	FUSE 15A X AGC15	57	022471	8	NUT HEX #8-32 STEEL
26	064009	1	LIGHT 12VDC .02A LED RED PILOT	58	022188	6	NUT HEX #6-32 STEEL
27	061945	1	SWITCH SELECTOR 6A AMP/V	59	036908	2	SCREW PPHM #6-32 X 1-1/4
28	076037	1	VOLTMETER DC 8-18V	60	0C2428	4	SCREW PHTT #6-32 X 1/2 ZYC
29	070081	1	HOURMETER	61	0C2323	4	SCREW PHTT #6-32 X 5/8 ZYC
30	070043	1	VOLTMETER AC 0-300	62*	0D5324	1	FUSE & HOLDER LITTEL 7.5A
31	070045	1	AMMETER AC 0-200	63*	0A9611	REF.	FUSE 7.5AXBK/AGC7.5NX

* PART OF CONTROL PANEL WIRE HARNESS

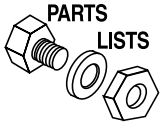

Section 7 — Exploded Views and Parts Lists

(Model No. 004626-0) Guardian Liquid-cooled 40 kW Generators

Control Panel - Drawing No. 0D6978-A

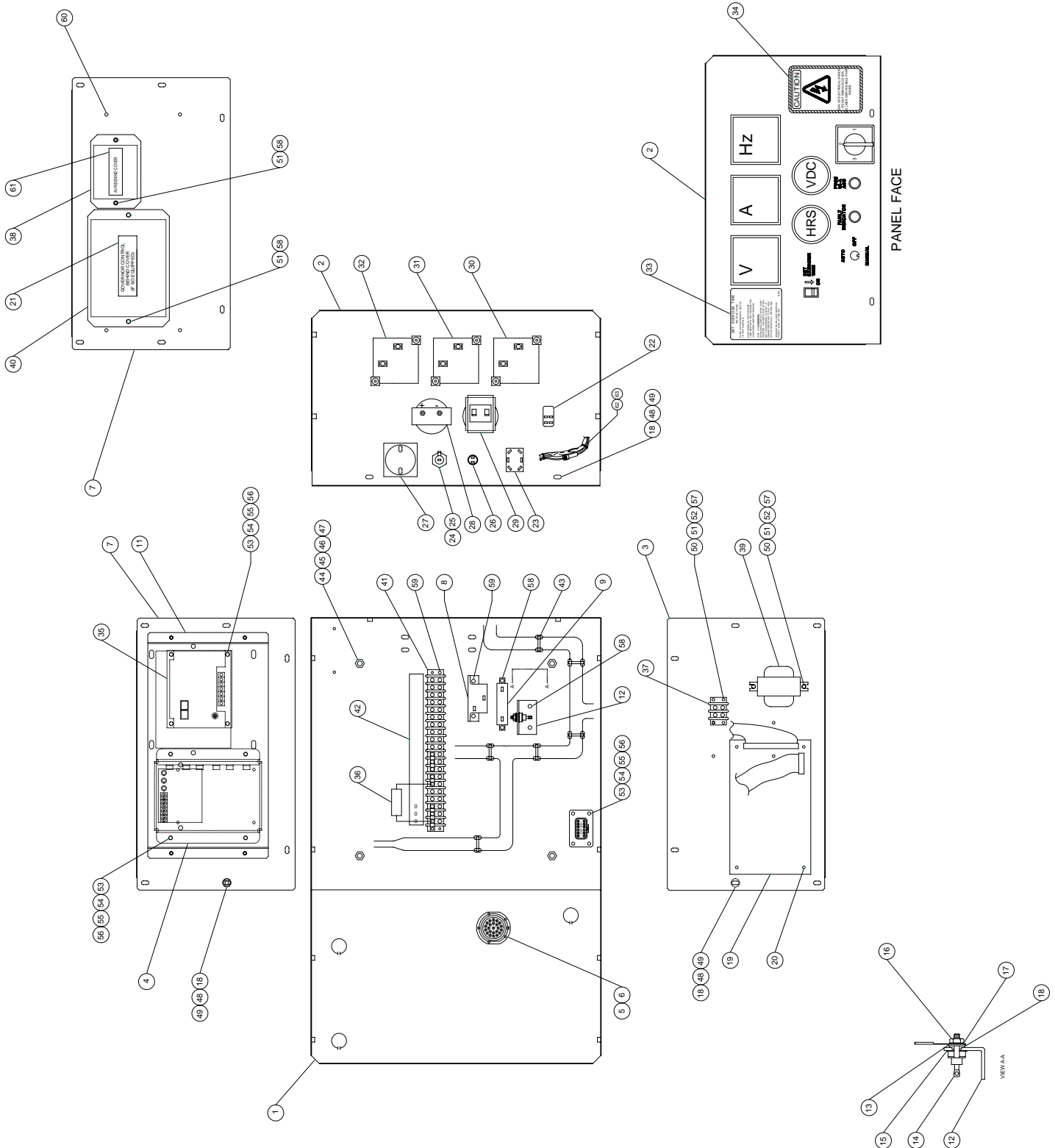

Section 7 — Exploded Views and Parts Lists
(Model No. 004626-0) Guardian Liquid-cooled 40 kW Generators
Control Panel - Drawing No. 0D6978-A

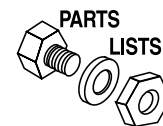

ITEM	PART NO.	QTY.	DESCRIPTION	ITEM	PART NO.	QTY.	DESCRIPTION
1	0D7397	1	PNL BTM & BACK CNTL PNL 04626	34	0C1229	1	DECAL CUST CONN BOX
2	0D1521A	1	CONTROL PANEL FRONT W/ SILK SCREEN	35	0D3440	1	CONTROLLER, B-C #DPG-2103
3	0D1522	1	PANEL SIDE COVER CONTROL PANEL	36	0A3968	1	CAPACITOR FILTER ASY
4	067680	1	ASSY VOLTAGE REGULATOR 60HZ	37	048766	REF	BLOCK TERM 20A 2 X 6 X 1100V
5	0C8243	1	WASHER LOCK HDP DEUTSCH	38	0A1441B	1	COVER PLATE AVR
6	0C8244	1	NUT, HDP DEUTSCH	39	083264	1	TFMR ASM,CMA 240/12V
7	0A6321	1	PANEL LEFT SIDE E	40	0A1441C	1	COVER PLATE EGOV
8	048467	1	CIRCT BRK 7 X 1 ETA 46-500-P	41	057335	REF	BLOCK TERM 20A 20 X 6 X 1100V
9	057907	1	RES WW LUG 10R 10% 25W	42	076061	1	DECAL TERM. STRIP
10	064008	1	COVER CON PNL TOP (NOT SHOWN)	43	029333	6	TIE WRAP 7.4" X .19" NATL UL
11	0A6323	1	CHASSIS AVR & E-GOV	44	040479	4	VIB MNT 1.0 X 1.0 X 1/4-20
12	055444	1	HEATSINK	45	022507	4	SCREW HHC 1/4-20 X 1/2 G5
13	030468	1	WASHER STEP NYLON .20	46	022127	4	NUT HEX 1/4-20 STEEL
14	049939	1	RECTIFIER MSC 12A 600V 1N1206R	47	022097	4	WASHER LOCK M6-1/4
15	070370	1	WASHER MICA .203	48	033121	14	SCREW HHC #10-32 X 1/2
16	022158	1	NUT HEX #10-32 STEEL	49	022152	14	WASHER LOCK #10
17	023762	1	WASHER SHAKEPROOF EXT #10 STL	50	036902	4	SCREW PPHM #6-32 X 1/2
18	023897	15	WASHER FLAT #10 ZINC	51	022155	6	WASHER LOCK #6
19	076009A	1	PP LOGIC ASM 50/60HZ	52	022985	8	WASHER FLAT #6 ZINC
20	040213	4	PCB SUPPORT SNAP-IN 1/4"	53	036918	8	SCREW PPHM #8-32 X 1/2
21	0A3394	1	DECAL, ELEC GOVERNOR	54	022264	8	WASHER LOCK #8-M4
22	082573	1	SWITCH ROCKER DPST 125V SPD	55	038150	8	WASHER FLAT #8 ZINC
23	076020	1	SWITCH TOG DPDT 15/10 SP	56	022471	8	NUT HEX #8-32 STEEL
24	032300	1	HOLDER FUSE	57	022188	6	NUT HEX #6-32 STEEL
25	022676	1	FUSE 15A X AGC15	58	0C2428	8	SCREW PHTT #6-32 X 1/2 ZYC
26	064009	1	LIGHT 12VDC .02A LED RED PILOT	59	0C2323	4	SCREW PHTT #6-32 X 5/8 ZYC
27	061945	1	SWITCH SELECTOR 6A AMP/V	60	0A2284	4	SCREW SWAGE 8-32 X 1/2 ZYC
28	076037	1	VOLTMETER DC 8-18V	61	0C1127	1	DECAL AVR COVER
29	070081	1	HOURMETER	62*	0D5324	4	FUSE & HOLDER LITTEL 7.5A
30	070043	1	VOLTMETER AC 0-300	63*	0A9611	1	FUSE 7.5AXBK/AGC7.5NX
31	070045	1	AMMETER AC 0-200				
32	070042	1	FREQUENCY METER 240V 55-65HZ				
33	081988	1	DECAL EXERCISE INFO				

* PART OF CONTROL PANEL WIRE HARNESS

Section 7 — Exploded Views and Parts Lists

**(Model No. 004373-1) Guardian Liquid-cooled 40 kW Generator
Electronic Governor – Drawing No. 0A2615-F**

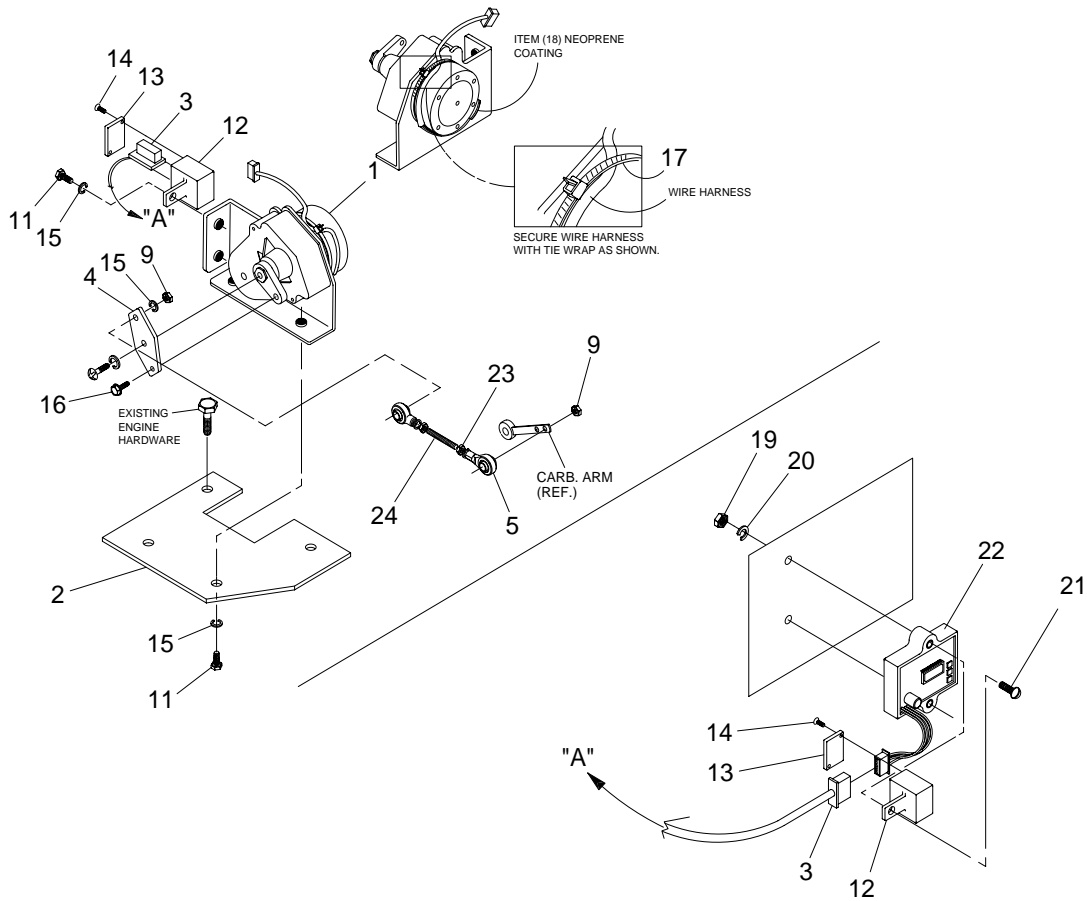

ITEM	PART NO.	QTY.	DESCRIPTION
1	098290	1	ASSEMBLY MOTOR STEPPER
2	0A3439	1	BRACKET GOVERNOR MOUNTING
3	098958A	1	CONNECTOR INTERFACE ASSEMBLY
4	021888	1	LEVER STEPPER MOTOR
5	082508	2	BALL JOINT PLA .25-.28
9	036409	2	NUT HEX 1/4-28 STEEL
11	043146	3	SCREW HHC M6-1.0 X 10 G8.8
12	098941A	2	HOUSING GOVERNOR CONNECT
13	098942A	2	COVER CONN HOUSING
14	098225	4	SCREW FHM #2 X 5/8 SELF TAP
15	022097	4	WASHER LOCK M6-1/4
16	064526	1	SCREW TAP HWH #6-25 X 3/8 ZINC
17	029333A	1	TIE WRAP 7.4" X .19" BLACK UL
18	074031	-	LIQUID NEOPRENE (NOT SHOWN)
19	051716	2	NUT HEX M5-0.8 G8 YEL CHR
20	049226	2	WASHER LOCK M5
21	076040	2	SCREW PPHM M5-0.8 X 16
22	098647	1	ASSEMBLY L.C. ELECTRONIC GOVERNOR
23	036409	2	NUT HEX 1/4-28 STEEL
24	0C2184	1	STUD THR 1/4-28 X 3-1/2 G2 ZINC

Section 7 — Exploded Views and Parts Lists

(Model Nos. 004373-1 & 004626-0) Guardian Liquid-cooled 40 kW Generator
Mounting Base – Drawing No. 0C4399-C

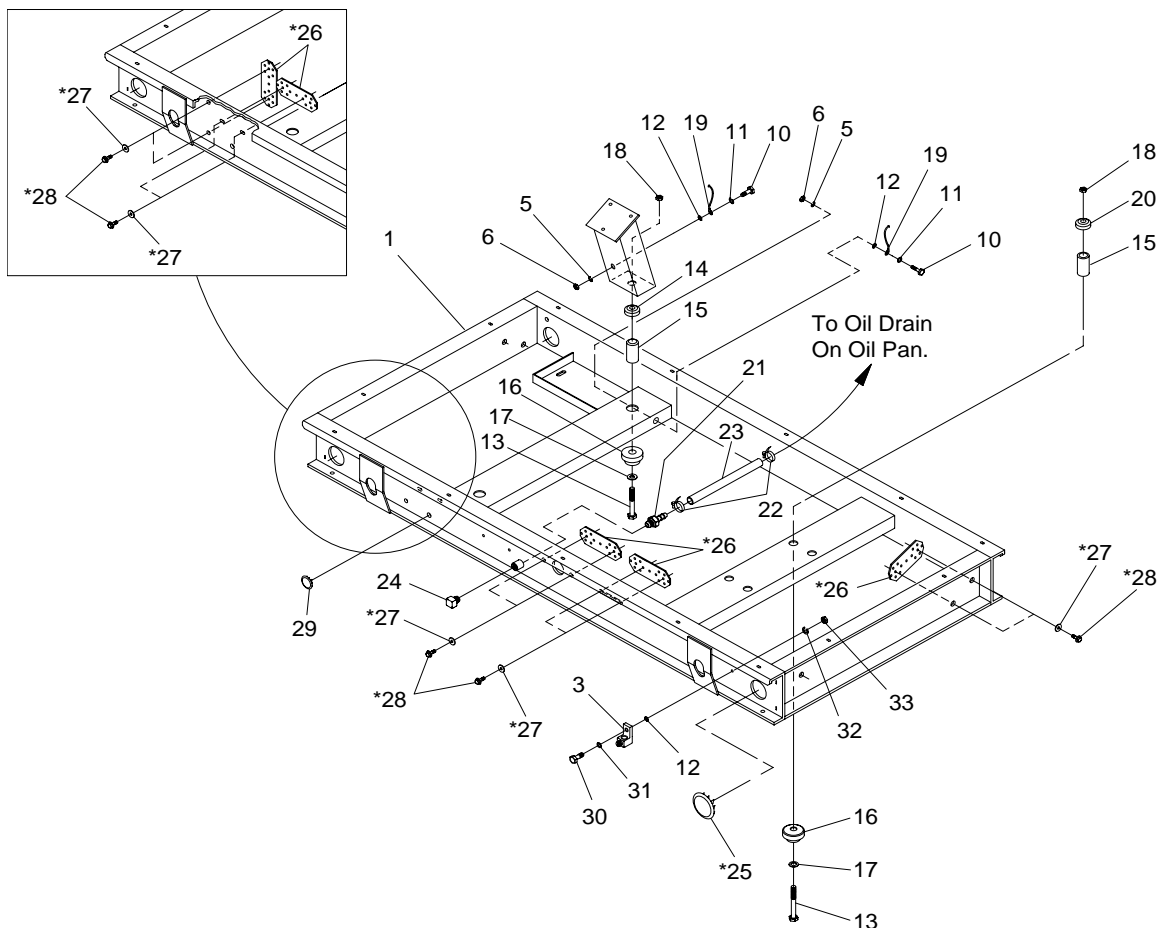
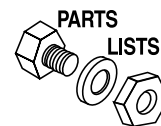

ITEM	PART NO.	QTY.	DESCRIPTION
1	0C3250	1	BASE, MOUNTING ASSEMBLY, 4.3L (DIRECT-COUPLED)
3	055414	1	LUG SLDLSS #2-#8 X 17/64 CU
5	022129	2	WASHER LOCK M8-5/16
6	045771	2	NUT HEX M8-1.25 G8 YEL CHR
10	043107	2	SCREW HHC M8-1.25 X 25 G8.8
11	022145	2	WASHER FLAT 5/16 ZINC
12	027482	3	WASHER SHAKEPROOF EXT 5/16 STL
13	055597	4	SCREW HHC M12-1.75 X 85 G8.8
14	052251	2	DAMPENER VIBRATION 40 BLUE
15	052257	4	SPACER .49 X .62 X 1.87 PWDR/ZINC
16	052252	4	DAMPENER VIBRATION
17	052259	4	WASHER FLAT M12
18	052860	4	NUT LOCKING M12-1.75
19	0536210098	1	ASSEMBLY GROUNDWIRE 10"/3/8
20	052251A	2	DAMPENER VIBRATION 50 WHITE
21	044118	1	BARBED STRAIGHT 1/2 NPT X 5/8
22	057823	2	CLAMP HOSE #10 .56 - 1.06
23	057448	11"	HOSE 5/8 ID TYPE 3 SINGLE
24	024310	1	PLUG STD PIPE 1/2 STEEL SQ HD

ITEM	PART NO.	QTY.	DESCRIPTION
* 25	0A8785	4	PLUG BUTTON 3" DIA.
* 26	0C4360	8	PLATE VARMINIT
* 27	071693	16	WASHER FLAT .281 ID X 1.0 OD
* 28	0C2454	16	SCREW TH-FRM M6-1 X 16 N WA Z/JS
* 29	0C4753	1	PLUG 3/4 BUTTON
30	022413	1	SCREW HHC 1/4-20 X 1 G5
31	022473	1	WASHER FLAT 1/4 ZINC
32	022097	1	WASHER LOCK M6-1/4
33	022127	1	NUT HEX 1/4-20 STEEL

NOTES: 1) * ITEMS 25, 26, 27, 28 & 29 ARE INCLUDED FOR UNITS WITH ENCLOSURES ONLY. NOT INCLUDED WITH OPEN SETS.
2) ITEM 25 (PLUG BUTTON 3" DIA.) IS USED AFTER SHIPPING. HOLES ARE TO REMAIN UNCOVERED FOR SHIPPING PURPOSES. PLUGS CAN BE FOUND IN THE MANUAL BAG LOCATED INSIDE THE LOWER CONNECTION BOX.

Section 7 – Exploded Views and Parts Lists

(Model Nos. 004373-1 & 004626-0) Guardian Liquid-cooled 40 kW Generator
 Engine Common Parts – Drawing No. 0A4304-J

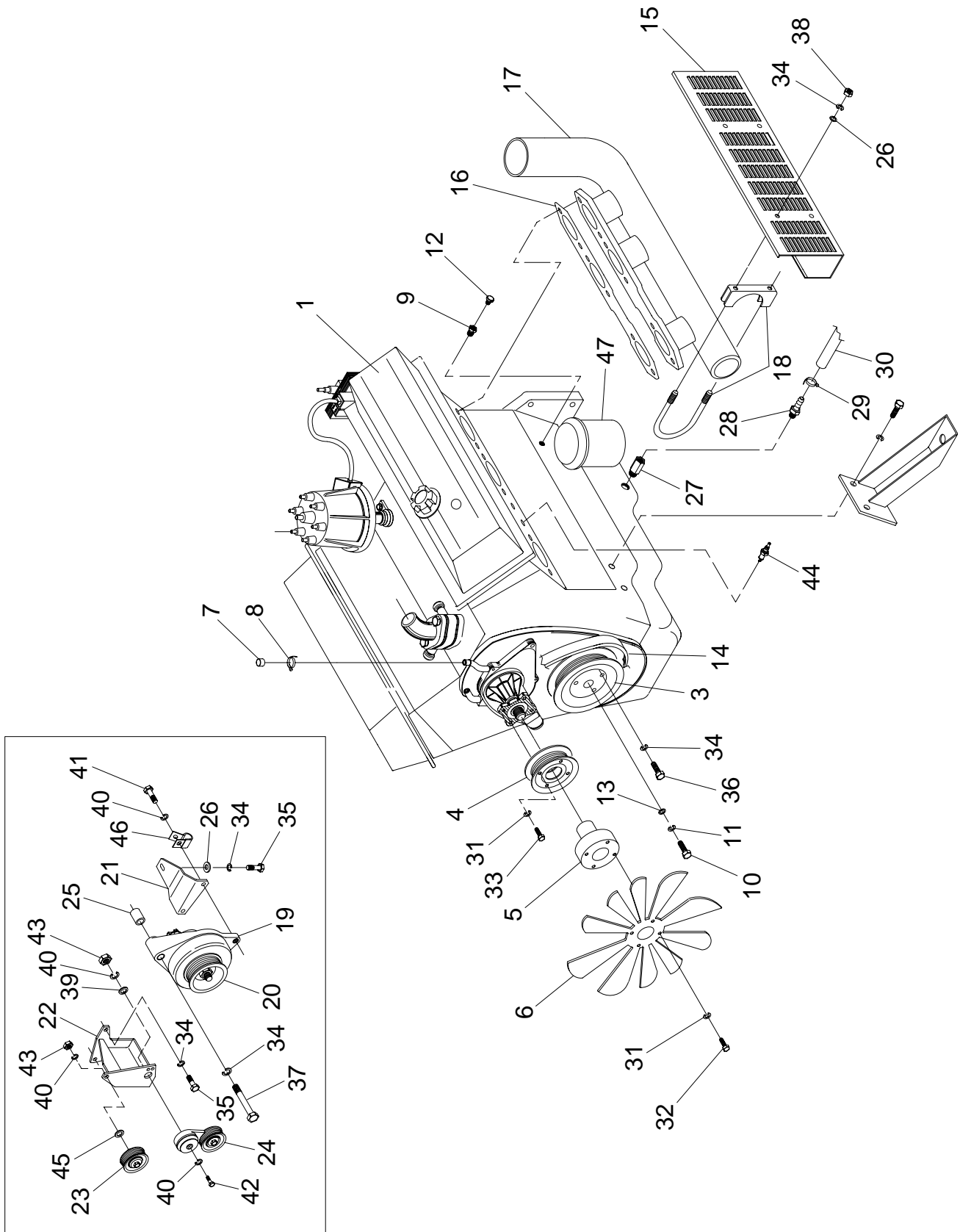

Section 7 — Exploded Views and Parts Lists

(Model Nos. 004373-1 & 004626-0) Guardian Liquid-cooled 40 kW Generator
Engine Common Parts – Drawing No. 0A4304-J

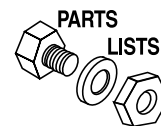

ITEM	PART NO.	QTY.	DESCRIPTION	ITEM	PART NO.	QTY.	DESCRIPTION
1	0A9046	1	ENGINE 4.3L GM	24	0C2885	1	PULLEY TENSIONER
3	0A4239	1	PULLEY CRANKSHAFT	25	0A4100G	1	SPACER DC ALTERNATOR 32MM
4	0A4240	1	PULLEY WATER PUMP	26	022131	8	WASHER FLAT 3/8-M10 ZINC
5	0A5640	1	SPACER FAN 50MM (35 KW UNITS ONLY)	27	077456	1	ADAPTOR M12-1.75 3/8 NPT
	0A5640A	1	SPACER FAN 62MM (45KW UNITS ONLY)	28	044117	1	BARBED STRAIGHT 3/8 NPT X 5/8
6	0A5639	1	FAN 17" REVRS ROT (35KW UNITS ONLY)	29	057823	1	CLAMP HOSE #10 .56 - 1.06
	0D3293A	1	FAN COOLING 22" DIA REVRS ROT (45KW UNITS ONLY)	30	057448	1	HOSE 5/8 ID TYPE 3 SINGLE (12")
7	077996	1	CAP HOSE	31	022129	8	WASHER LOCK M8-5/16
8	057823	1	CLAMP HOSE #10 .56 - 1.06	32	022142	4	SCREW HHC 5/16-18 X 3/4 G5 (45KW)
9	035579	1	BUSHING REDUCER 1/4 TO 1/8	33	048614	4	SCREW HHC 5/16-24 X 3/4 G5
10	037065	1	SCREW HHC 7/16-20 X 2-1/4 G5	34	022237	12	WASHER LOCK 3/8
11	022302	1	WASHER LOCK 7/16	35	029745	4	SCREW HHC 3/8-16 X 1 G5
12	0A8584	1	SWITCH OIL PRESSURE	36	042633	3	SCREW HHC 3/8-24 X 1 G5
13	052644	1	SPACER .5 X 1.5 X .25 STL/ZINC	37	033819	1	SCREW HHC 3/8-16 X 4 G5
14	0A4278A	1	BELT SERPENTINE 72.5"	38	022241	4	NUT HEX 3/8-16 STEEL
15	0A4930A	1	HEAT SHIELD LEFT	39	0A5768	1	WASHER FLAT HEAVY DUTY
16	0A4085	1	GASKET EXHAUST MANIFOLD	40	046526	5	WASHER LOCK M10
17	0A3927	1	MANIFOLD LEFT EXHAUST	41	049814	2	SCREW HHC M10-1.5 X 25 G8.8
18	0C7947	2	BOLT U 3/8-16 X 2.50	42	0C3756	1	BOLT TENSIONER PULLEY
19	0A1232	1	DC ALTERNATOR ASSEMBLY	43	045772	2	NUT HEX M10-1.5 G8 YEL CHR
20	0A7801B	1	PULLEY PLOY-V 82 OD.	44	0D2514	8	SPARK PLUG 5.7L GM
21	021928	1	BRACKET ALT. SUPPORT	45	052259	1	WASHER FLAT M12
22	0C6239	1	ASSEMBLY BRACKET MOUNTING WELD	46	055934D	1	CLAMP VINYL 1.06 X .406 Z
23	0A4241	1	PULLEY GROOVED IDLER	47	0A37970001	1	FILTER OIL



Section 7 – Exploded Views and Parts Lists

(Model Nos. 004373-1 & 004626-0) Guardian Liquid-cooled 40 kW Generators
Engine Parts – Drawing No. 0D6980

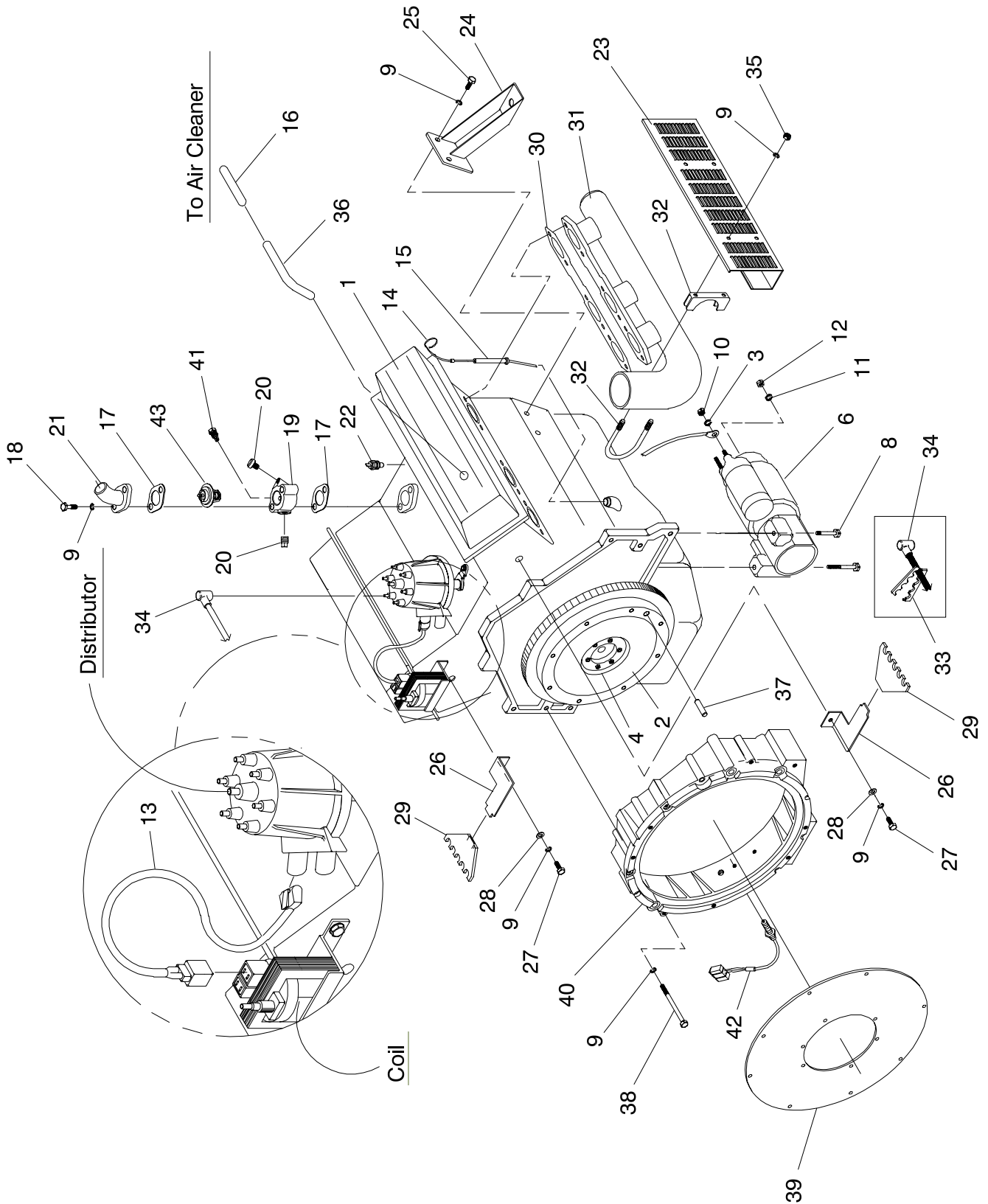

Section 7 — Exploded Views and Parts Lists

(Model Nos. 004373-1 & 004626-0) Guardian Liquid-cooled 40 kW Generators
Engine Parts – Drawing No. 0D6980

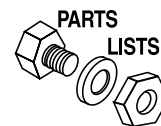

ITEM	PART NO.	QTY.	DESCRIPTION	ITEM	PART NO.	QTY.	DESCRIPTION
1	0A9046	1	ENGINE 4.3L GM	27	023152	2	SCREW HHC 3/8-16 X 3/4 G5
2	0A9118A	1	FLYWHL 4.3L GM SAE	28	022131	2	WASHER FLAT 3/8-M10 ZINC
3	070022	1	WASHER STAR M12 EXT	29	058030	2	RETAINER PLUG WIRES
4	0A6021	6	SCREW HHC 7/16-20 X 1 G8	30	0A4085	1	GASKET EXHAUST MANIFOLD
6	059056A	1	STARTER 5.7L/7.4L GM	31	0A3928	1	MANIFOLD RIGHT EXHAUST
8	0A9050	2	BOLT STARTER 4.3L	32	0C7947	2	BOLT U 3/8-16 X 2.50
9	022237	17	WASHER LOCK 3/8	33	057794	2	RETAINER SPARK PLUG WIRES
10	045772	1	NUT HEX M10-1.5 G8 YEL CHR	34	0A4277	1	WIRES SPARK PLUG 4.3L
11	049226	1	WASHER LOCK M5	35	022241	4	NUT HEX 3/8-16 STEEL
12	051716	1	NUT HEX M5-0.8 G8 YEL CHR	36	057795	1	CONNECTOR C/C VENT
13	0A4244	1	CONNECTOR COIL TO DISTRIBUTOR	37	048191	2	PIN DOWEL M10 X 24
14	0A4215	1	DIP STICK 4.3L GM	38	032303	6	SCREW HHC 3/8-16 X 3-1/2 G5
15	0A4231	1	TUBE DIP STICK 4.3L	39	0A3852	3	PLATE FLEX GM
16	059057	10"	HOSE 3/4 ID SAE-30R2	40	098239	1	CASTING ADAPTOR
17	0A2440	2	GASKET THERMOSTAT	41	057522	1	SENSOR COOLANT LEVEL
18	026568	2	SCREW HHC 3/8-16 X 2-3/4 G5	42	0D2244M	1	ASSY MAGPICKUP (3/8-24 MALE) (MODEL 004626 ONLY)
19	099729A	1	HOUSING THERM IMPREX	43	075885	1	THERMOSTAT 195 DEG
20	061012	1	PLUG STD PIPE 1/8 SOCKET HEAD				
21	069939	1	HOUSING THERMOSTAT/WATER INLET				
22	035606	1	SENSOR HI COOLANT SHUTDOWN				
23	0A4930B	1	HEAT SHIELD RIGHT	*	0D6979	1	40KW GUARDIAN WIRE HARNESS (NOT SHOWN FOR MOD. 004626-0)
24	0A4084	1	MOUNT ENGINE R & L	*	0A4308	1	HARNESS 4.3L STD WIRE (NOT SHOWN FOR MOD. 004373-1)
25	029745	3	SCREW HHC 3/8-16 X 1 G5				
26	044101	2	SPARK PLUG WIRE SUPPORT BRACKET				

NOTE:

TORQUE ITEM #6 TO 24 FT/LB AND USE
THREAD LOCKING COMPOUND (T-13717).

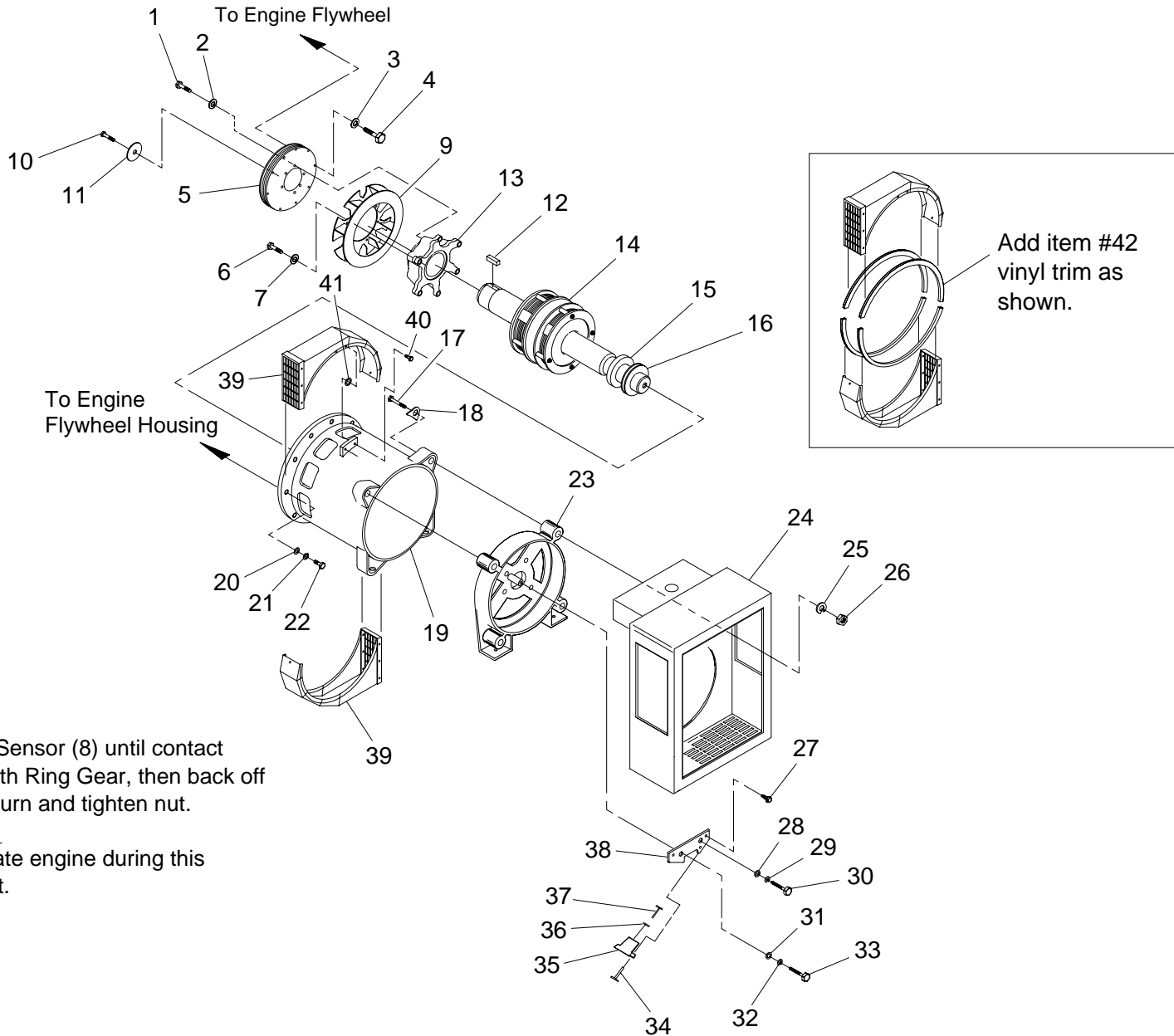

Note:

Thread in Sensor (8) until contact is made with Ring Gear, then back off 1/2 to 3/4 turn and tighten nut.

Caution:

Do not rotate engine during this adjustment.



Section 7 — Exploded Views and Parts Lists

(Model Nos. 004373-1 & 004626-0) Guardian Liquid-cooled 40 kW Generators
Generator – Drawing No. 0D5333-A

Section 7 — Exploded Views and Parts Lists

(Model Nos. 004373-0 & 004626-0) Guardian Liquid-cooled 40 kW Generators
Generator – Drawing No. 0D5333-A

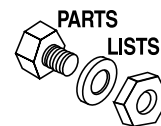

ITEM	PART NO.	QTY.	DESCRIPTION	ITEM	PART NO.	QTY.	DESCRIPTION
1	051768	6	SCREW HHC M12-1.75 X 25 G8.8	23	068113	1	CARRIER REAR BEARING 15"
2	051769	6	WASHER LOCK M12	24	068115	1	LOWER PANEL 15
3	022237	8	WASHER LOCK 3/8	25	043123	4	WASHER LOCK M14
4	043097	8	SCREW SHC 3/8-16 X 1 G8.8 NZ	26	051779	4	NUT HEX M14-2.0 G8 YEL CHR
5	0A3852	3	PLATE FLEX GM	27	046852	1	SCREW HHTT #10-32 X 1/4 BP
6	055173	6	SCREW HHC M8-1.25 X 20 G10.9	28	022250	1	WASHER FLAT 7/16
7	022129	6	WASHER LOCK M8-5/16	29	051769	1	WASHER LOCK M12
9	0A5526	1	FAN ASSEMBLY 390 SAE DD	30	057821	1	SCREW HHC M8-1.25 X 40 G8.8
10	0A2601	1	SCREW HHC M16-2.0 X 45 G8.8	31	022145	1	WASHER FLAT 5/16 ZINC
11	0A2602	1	WASHER FLAT .688 ID X 3.25 OD	32	022129	1	WASHER LOCK M8-5/16
12	0A1138	1	KEY SQ 3/8 X 2-1/2 STEEL	33	057821	4	SCREW HHC M8-1.25 X 40 G8.8
13	021941	1	COUPLER 390 SAE	34	024044A	2	ASSEMBLY BRUSH & SHUNT
14	020808A	1	ROTOR 390 40 1P DIRECT	35	023877D	4	BRUSH HOLDER-UNIV
15	052624	1	BEARING BALL 6212 SEALED	36	022155	4	WASHER LOCK #6
16	070892	1	SLIP RING -MACHINED-	37	025105	4	SCREW RHM 6-32 X 1/4 SIMS
17	065477	4	SCREW HHC M14-2.0 X 150 G8.8	38	071639	1	HOLDER BRUSH SUPPORT
18	0A1633	4	WASHER 390 SAE ALT	39	0A4089	1	ASSEMBLY SCROLL 390 SAE
19	020729A	1	STATOR 390 40AD2 SAE	40	0A2437	2	SCREW SWAGE 1/4-20 X 5/8 Z/YC
20	022131	12	WASHER FLAT 3/8-M10 ZINC	41	022473	2	WASHER FLAT 1/4 ZINC
21	046526	12	WASHER LOCK M10	42	056326	8.4'	TRIM VINYL BLACK 1/8 GP
22	057642	12	SCREW HHC M10-1.5 X 40 G8.8				

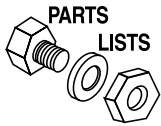

Section 7 – Exploded Views and Parts Lists

(Model Nos. 004373-1 & 004626-0) Guardian Liquid-cooled 40 kW Generators
Compartment – Drawing No. 0C4401-F

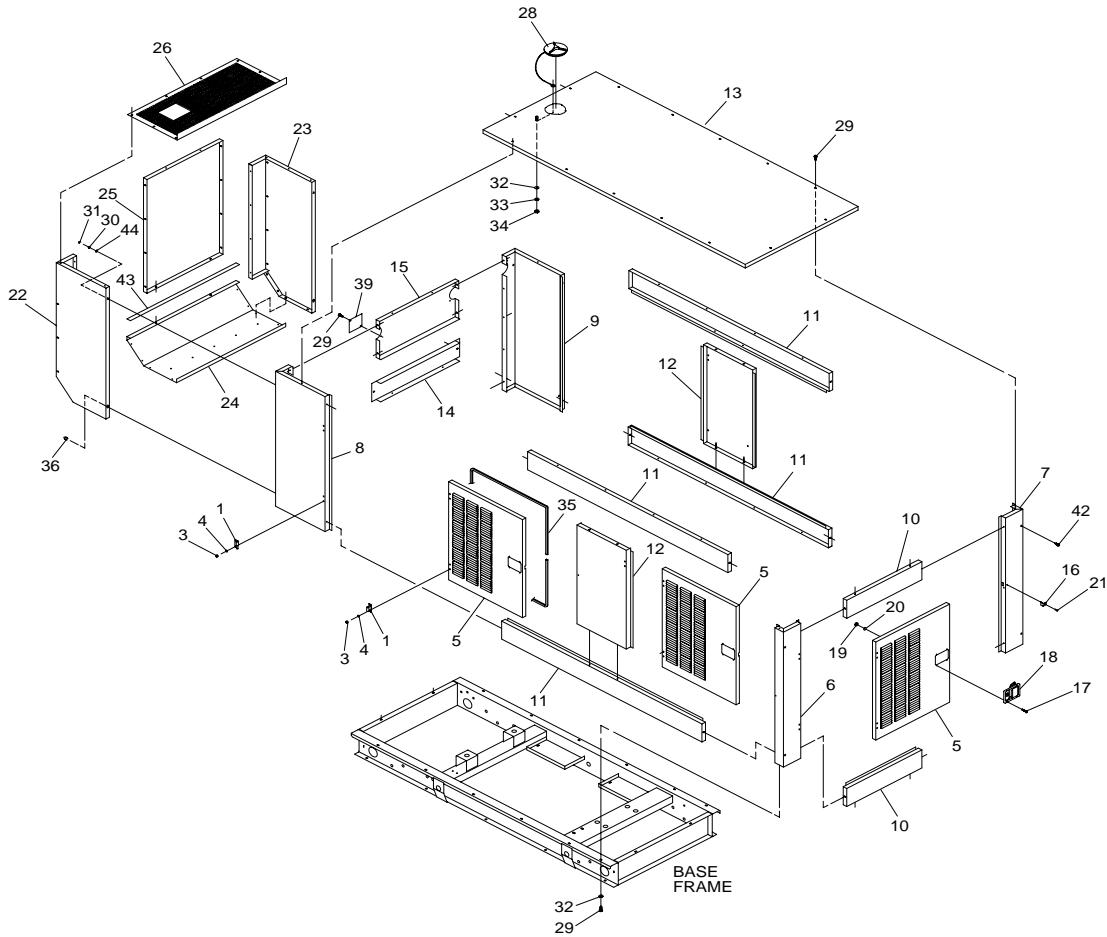

ITEM	PART NO.	QTY.	DESCRIPTION	ITEM	PART NO.	QTY.	DESCRIPTION
1	0C3594	10	ASSEMBLY M6 HINGE	23	0C4064 (A)	1	DUCT FRONT RH
3	0A3359	40	SCREW BHSC M6-1.0 X 16 SS	24	0C4066 (A)	1	DUCT BOTTOM
4	0A3360	40	SHAKEPROOF INT M6 SS	25	0C4067 (A)	1	DUCT FRONT PANEL
5	0C2522 (A)	5	DOOR SMALL STD. WELD	26	0C4117 (A)	1	DUCT FRONT TOP RH
6	0C2527 (A)	1	CORNER POST LH REAR	28	0C2634A	1	ASSEMBLY COVER ACCESS
7	0C2528 (A)	1	CORNER POST RH REAR	29	0C2454	76	SCREW TH-FRM M6-1X16 N WA Z/JS
8	0C2535 (A)	1	CORNER POST LH FRONT	30	022129	2	WASHER LOCK M8-5/16
9	0C2536 (A)	1	CORNER POST RH FRONT	31	042907	2	SCREW HHC M8-1.25 X 16 G8.8
10	0C2547 (A)	2	REAR BRACE TOP & BOTTOM	32	022473	15	WASHER FLAT 1/4 ZINC
11	0C2550 (A)	4	SIDE BRACE TOP & BOTTOM	33	022097	1	WASHER LOCK M6-1/4
12	0C2555 (A)	2	SIDE SUPPORT	34	022127	1	NUT HEX 1/4-20 STEEL
13	0C2560 (A)	1	ROOF ONE-PIECE WLDMT	35	0A9881	49.1 FT.	GASKET DOOR RUBBER
14	0C2642 (A)	1	FRONT BRACE BOTTOM (2.4L & 4.3L)	36	0C3393	2	SCREW SHOULDER
	0C4567 (A)	1	FRONT BRACE BOTTOM (3.0L D ONLY)	39	0C3400 (A)	1	COVER EXHAUST HOLE
15	0C2641 (A)	1	FRONT BRACE TOP (2.4L & 4.3L)	42	0C3397	4	FASTENER RATCHET
	0C4566 (A)	1	FRONT BRACE TOP (3.0L D ONLY)	43	066760	39-3/8"	STRIP SEALANT 1/8 X 1
16	0C2633	5	PLATE STRIKER GEN 2000	44	022145	2	WASHER FLAT 5/16 ZINC
17	0C6749	20	SCREW PPHM M4-0.7 X 12 SS				
18	060069	5	PADDLE HANDLE LOCK				
19	0C6748	20	NUT LOCK HEX M4-0.7 SS NYL INS				
20	080490	20	WASHER FLAT #8 SS				
21	087233	5	RIVET POP 3/16 X 1/4				
22	0C4065 (A)	1	DUCT FRONT LH				

OPTIONAL COMPARTMENT MATERIALS:
ALL P/N'S WITH AN "A" SUFFIX INDICATE
ALUMINUM MATERIAL OPTION.

Section 7 — Exploded Views and Parts Lists
(Model Nos. 004373-1 & 004626-0) Guardian Liquid-cooled 40 kW Generators
Radiator – Drawing No. 0D4991-A

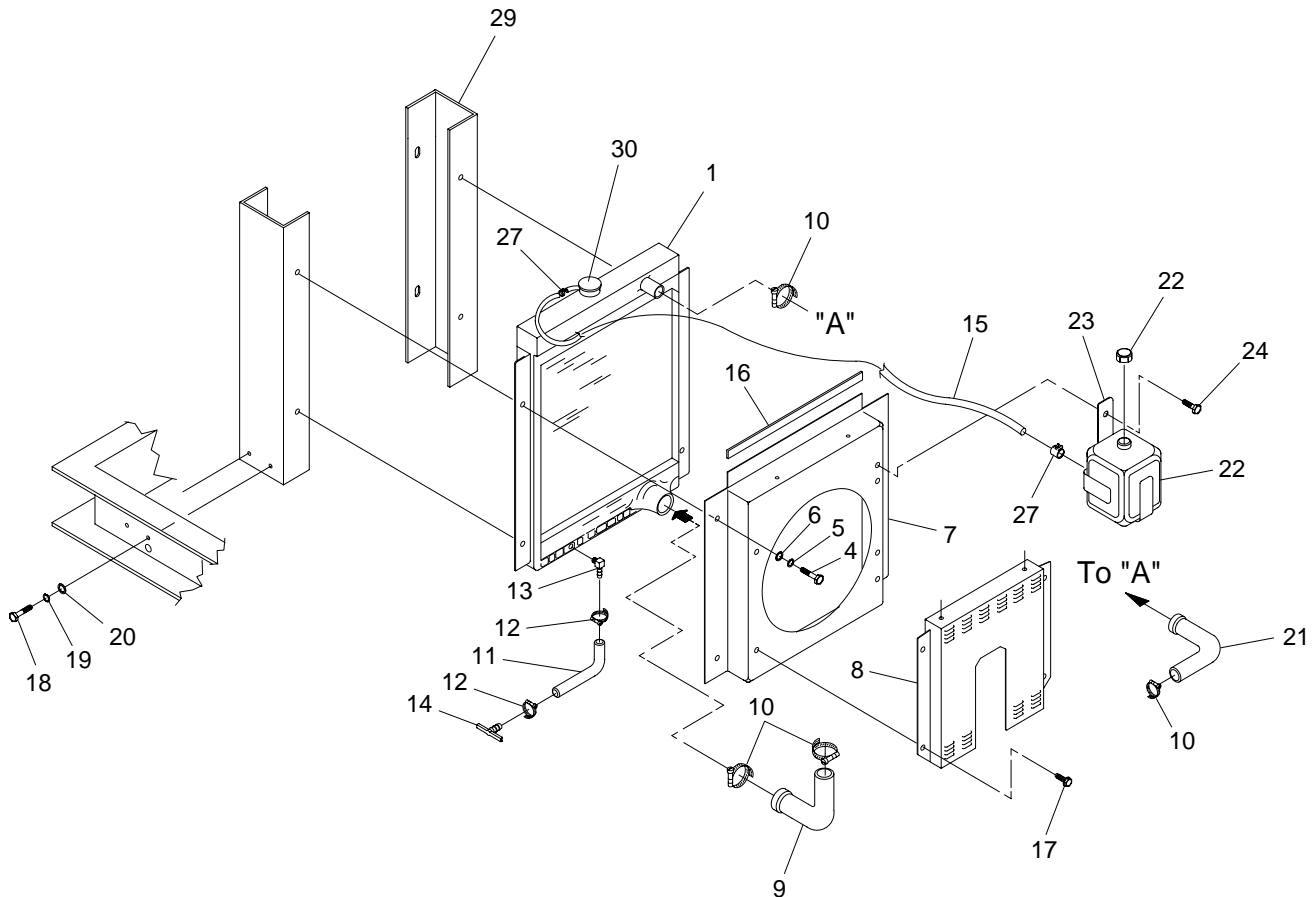
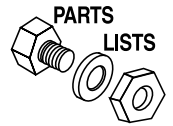

ITEM	PART NO.	QTY.	DESCRIPTION
1	068928	1	RADIATOR 14 FIN/INCH
4	024655	4	SCREW HHTT 1/4-20 X 1 CZ
5	022097	4	WASHER LOCK M6-1/4
6	022473	4	WASHER FLAT 1/4 ZINC
7	097246A	1	VENTURI 16" DIA 35KW
	097246B	1	VENTURI 18" DIA 45KW
8	0A5397	1	GUARD FAN 4.3L D.C.
9	0A4375	1	HOSE 4.3L STD LOWER
10	035685	4	CLAMP HOSE #28 1.32 - 2.25
11	047290	16"	HOSE 3/8 ID SINGLE BRAID
12	040173	2	CLAMP HOSE #5.5 .62 - .62
13	049340	1	BARBED ELBOW 90 1/4 NPT X 3/8
14	036865	1	DRAINCOCK
15	029032	46"	HOSE 9/32 ID
16	052250	2	TAPE FOAM 1 X 1
17	058443	9	SCREW CRIMPTITE 1/4-20 X 5/8
18	029745	4	SCREW HHC 3/8-16 X 1 G5
19	022237	4	WASHER LOCK 3/8
20	022131	4	WASHER FLAT 3/8-M10 ZINC
21	0A4374	1	HOSE 4.3L STD UPPER
22	076749	1	TANK COOLANT RECOVERY
23	080712	1	BRACKET COOLANT RECOVERY TANK
24	090388	1	SCREW HHTT M6-1.0 X 12 YC
27	048031C	1	CLAMP HOSE BAND 1/4
29	0C4341	2	SUPPORT RADIATOR A GROUP
30	046627	1	CAP RADIATOR

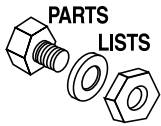

Section 7 — Exploded Views and Parts Lists

(Model No. 004373-1) Guardian Liquid-cooled 40 kW Generators
Carburetor – Drawing No. 0A5764-E

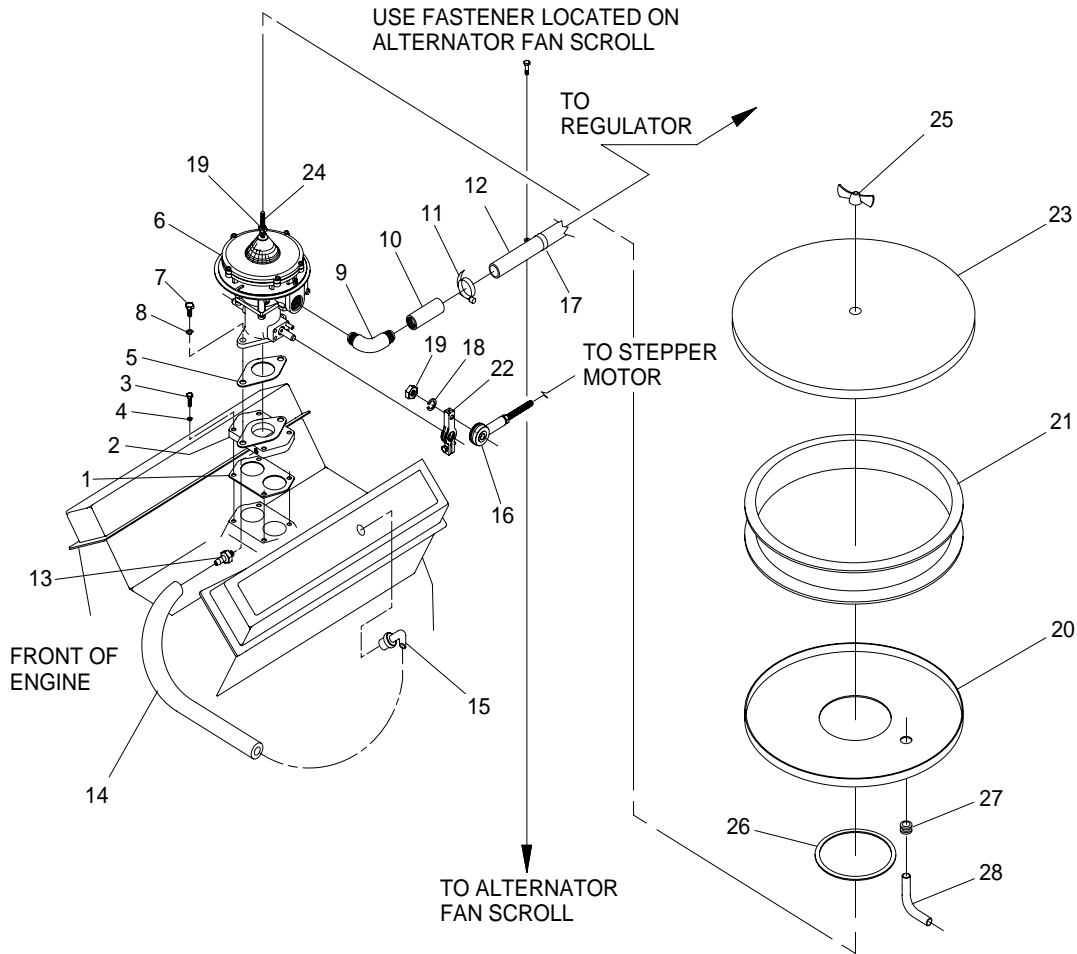

ITEM	PART NO.	QTY.	DESCRIPTION	ITEM	PART NO.	QTY.	DESCRIPTION
1	064945	1	GASKET CARBURETOR ADAPTOR	16	082508	1	BALL JOINT PLA .25-28
2	0A4120	1	ADAPTOR CARBURETOR W/INLET	17	055934Z	1	CLAMP VINYL 1.13 X .406 Z
3	033212	4	SCREW HHC 5/16-18 X 1-1/4 G5	18	022097	1	WASHER LOCK M6-1/4
4	022129	4	WASHER LOCK M8-5/16	19	036409	2	NUT HEX 1/4-28 STEEL
5	052865	1	CARBURETOR GASKET	20	0A4632B	1	PLATE AIR CLEANR BOTTOM
6	0A7631	1	CARB. REWORK 4.3L (NATURAL GAS + VAPOR)	21	0A4637	1	FILTER AIR 11.5"
	0C5716	1	CARBURETOR, REWORK (LPG LIQUID)	22	0A5763	1	ARM THROTTLE - REWORK
7	029745	2	SCREW HHC 3/8-16 X 1 G5	23	0A4632A	1	PLATE AIR CLEANER TOP
8	022237	2	WASHER LOCK 3/8	24	062522	1	STUD THR 1/4-20 X 3 G2 ZNC FULL
9	026307	1	ELBOW 90 DEG STREET 3/4	25	037561	1	NUT WING 1/4-20 NYLK
10	028641	1	TOE NIPPLE 3/4 NPT x 2	26	061258	1	GASKET AIR CLEANER
11	057824	1	CLAMP HOSE #16 .87 - 1.50	27	057796	1	GROMMET
12	057422	1	HOSE 1IN ID LP GAS (NATURAL GAS + VAPOR) (3.6')	28	057795	1	CONNECTOR C/C VENT
	057422	1	HOSE 1IN ID LP GAS (LPG LIQUID) (1')	29*	0A5737B	1	SPACER DC ALT. 30LG (LP GAS)
13	0A6344	1	BARBED ELBOW 90 1/8 NPT X 3/8		0A5737C	1	SPACER DC ALT. (VAPOR & NATURAL GAS)
14	047290	1	HOSE 3/8 ID SINGLE BRAID (.75')				
15	0A4121	1	VALVE PCV				

* NOT SHOWN

Section 7 — Exploded Views and Parts Lists
(Model No. 004626-0) Guardian Liquid-cooled 40 kW Generators
Carburetor – Drawing No. 0D6977

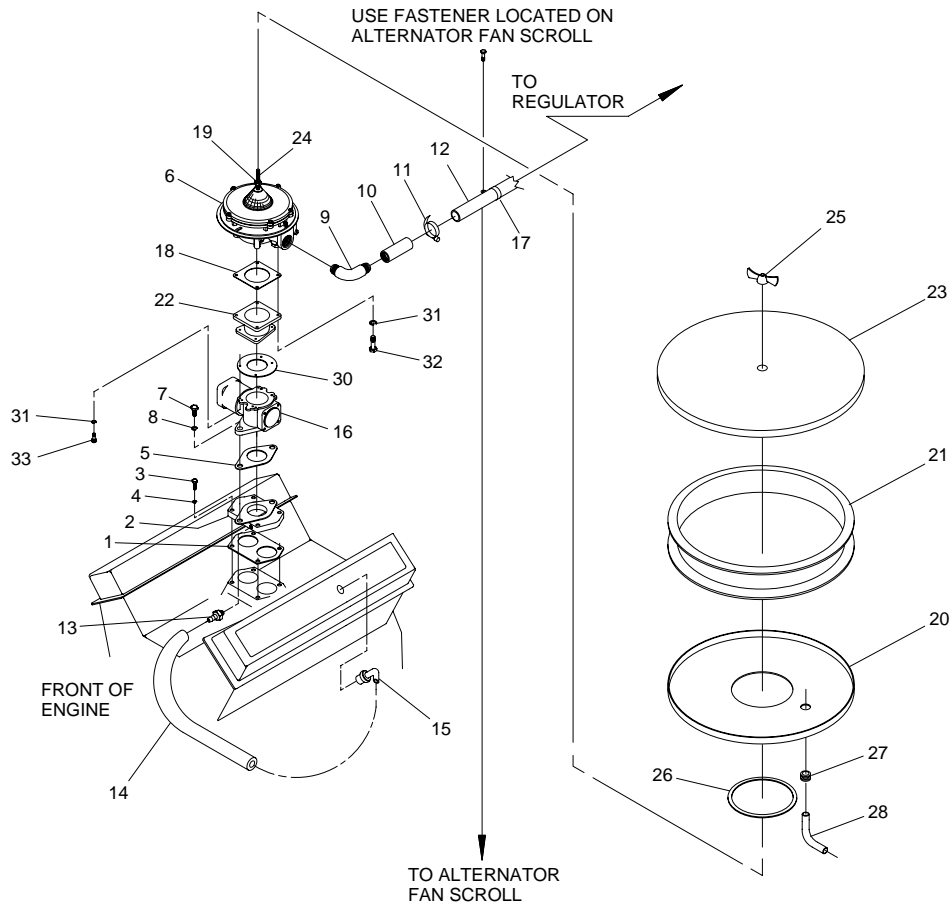
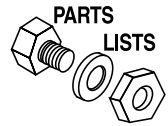

ITEM PART NO. QTY. DESCRIPTION

ITEM PART NO. QTY. DESCRIPTION

1	064945	1	GASKET CARBURETOR ADAPTOR
2	0A4120	1	ADAPTOR CARBURETOR W/INLET
3	033212	4	SCREW HHC 5/16-18 X 1-1/4 G5
4	022129	4	WASHER LOCK M8-5/16
5	0C7059	1	GASKET GOVERNOR THROTTLE BODY
6	0C7650A	1	MIXER (ONLY) NATURAL GAS
7	029745	2	SCREW HHC 3/8-16 X 1 G5
8	022237	2	WASHER LOCK 3/8
9	026307	1	ELBOW 90 DEG STREET 3/4
10	028641	1	NIPPLE TOE (THREADED ONE END) 3/4 NPT X 2
11	057824	1	CLAMP HOSE #16 .87-1.50
12	057422	44"	HOSE 1 IN ID LP GAS
13	0A6344	1	BARBED ELBOW 90 1/8 NPT X 3/8
14	047290	9"	HOSE 3/8 ID SINGLE BRAID
15	0A4121	1	VALVE PCV
16	0D2803	1	ACTUATOR THROTTLE 42MM
17	055934Z	1	CLAMP VINYL 1.13 X .406 Z
18	0A6613	1	GASKET CARB IMPCO 225

19	036409	1	NUT HEX 1/4-28 STEEL
20	0A4632B	1	PLATE AIR CLEANR BOTTOM
21	0A4637	1	FILTER AIR 11.5"
22	0C7820	1	MACHINING CARBURETOR ADAPTOR
23	0A4632A	1	PLATE AIR CLEANER TOP
24	062522	1	STUD THR 1/4-20 X 3 G2 ZNC FULL
25	037561	1	NUT WING 1/4-20 NYLK
26	061258	1	GASKET AIR CLEANER
27	057796	1	GROMMET
28	057795	1	CONNECTOR C/C VENT
29*	0A5737C	1	SPACER DC ALTERNATOR
30	0C7060	1	GASKET CARBURETOR ADAPTOR
31	022152	8	WASHER LOCK #10
32	064090	4	SCREW PHM SEMS #12-24 X 5/8 EX
33	0C7908	4	SCREW SHC #10-32 X 5/8 G8.8 NZ

* NOT SHOWN

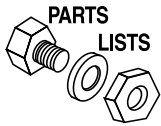

Section 7 — Exploded Views and Parts Lists

Guardian Liquid-cooled 40 kW Generators Regulator – Drawing No. 0C2776-C

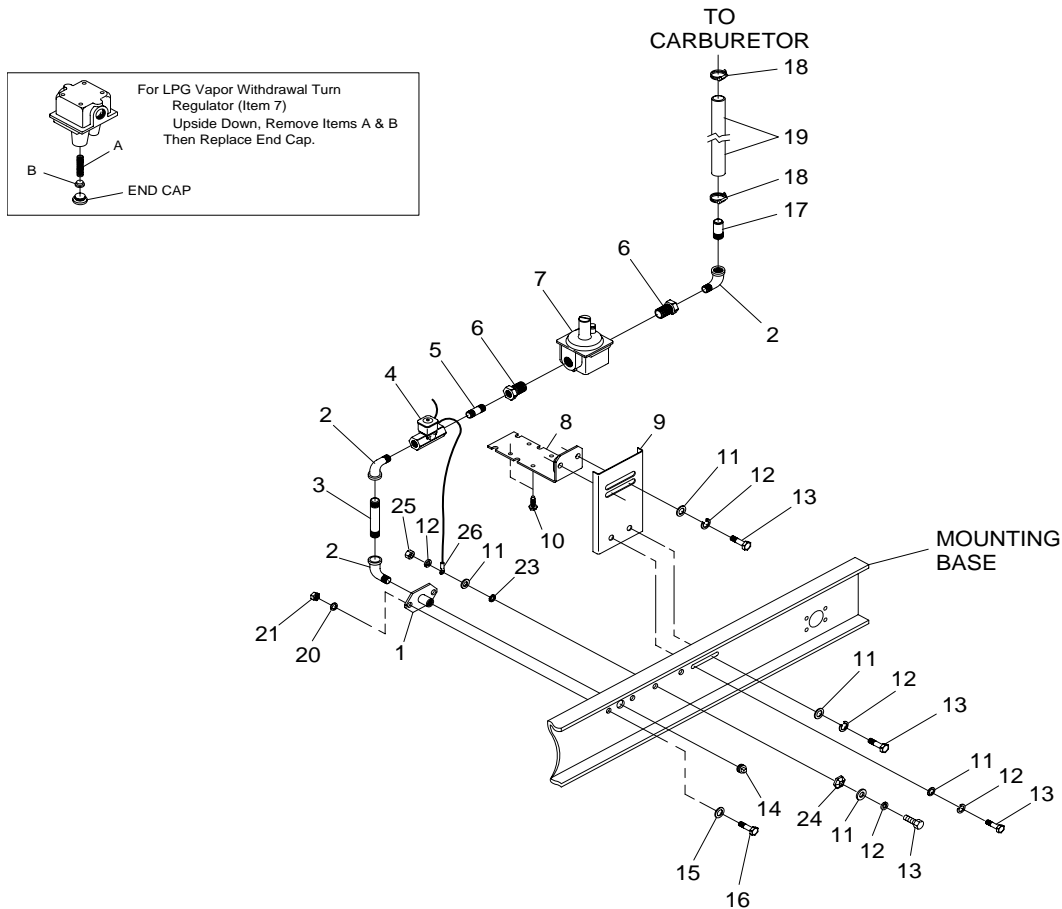

ITEM	PART NO.	QTY.	DESCRIPTION	ITEM	PART NO.	QTY.	DESCRIPTION
1	065907	1	SUPPORT SOLENOID NAT GAS	17	028641	1	NIPPLE TOE 3/4 NPT X 2
2	026307	3	ELBOW 90 DEG STREET 3/4	18	057824	2	CLAMP HOSE #16 .87 - 1.50
3	076691	1	NIPPLE PIPE 3/4NPTX4.5 BLK IRN	19	057422	1	HOSE 1IN ID LP GAS
4	043768A	1	SOLENOID GAS FUEL	20	043123	2	WASHER LOCK M14
5	026490	1	NIPPLE PIPE 3/4 NPT X 2	21	051779	2	NUT HEX M14-2 G8 YEL CHR
6	026577	2	BUSHING REDUCER 1 TO 3/4	22*	055934P	1	CLAMP VINYL 1.62 X .486 Z
7	055944	1	REGULATOR NAT GAS LPG VAPOR	23	027482	1	WASHER SHAKEPROOF EXT 5/16 STL
8	067018	1	SUPPORT REGULATOR	24	0C3168	1	WASHER LOCK SPECIAL 5/16
9	0C2775	1	BRACKET REGULATOR 4.3L	25	022259	1	NUT HEX 5/16-18 STEEL
10	061910	4	SCREW HHTT #10-24 X 3/4 CZ	26	058359	1	LUG RNGTNG INS 22-18 X 5/16 X .477
11	022145	6	WASHER FLAT 5/16 ZINC				
12	022129	6	WASHER LOCK M8-5/16				
13	030795	4	SCREW HHC 5/16-18 X 1 G5				
14	025655	1	PLUG STD PIPE 3/4 STEEL SQ HD				
15	022132	2	WASHER FLAT 9/16 ZINC				
16	051778	2	SCREW HHC M14-2.0 X 25 G8.8				

* NOT SHOWN

NOTE: ITEM #22 ATTACHES TO ALTERNATOR SCROLL

Section 7 — Exploded Views and Parts Lists
(Model No. 004626-0) Guardian Liquid-cooled 40 kW Generators
Carburetor – Drawing No. 0D4823-A

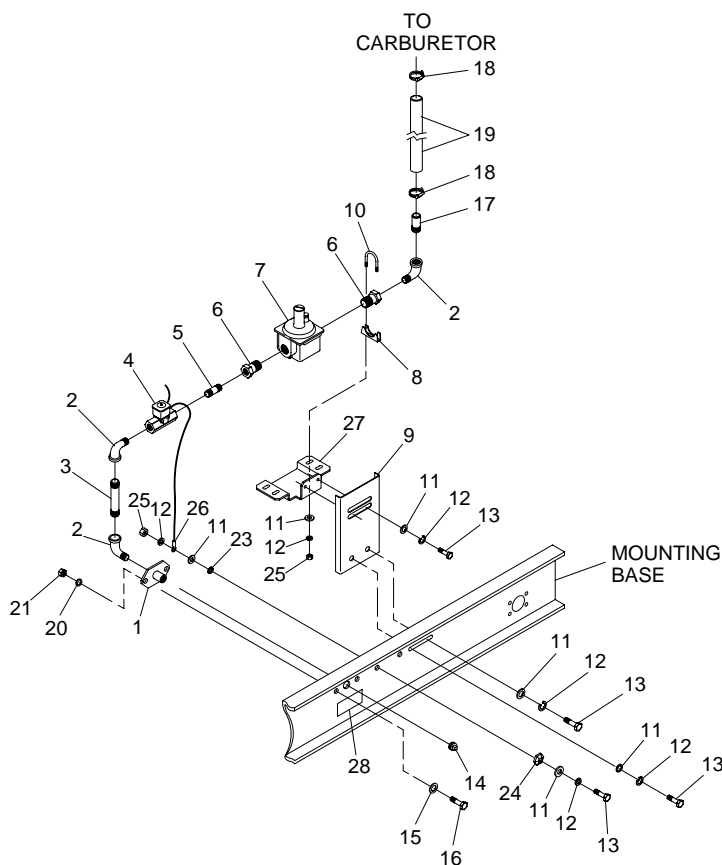
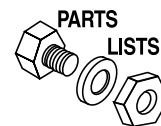

ITEM	PART NO.	QTY.	DESCRIPTION	ITEM	PART NO.	QTY.	DESCRIPTION
1	065907	1	SUPPORT SOLENOID NAT GAS	18	057824	2	CLAMP HOSE #16 .87-1.50
2	026307	3	ELBOW 90 DEG STREET 3/4	19	057422	1	HOSE 1 IN ID LP GAS
3	076691	1	NIPPLE PIPE 3/4 NPT X 4.5 BLK IRN	20	043123	2	WASHER LOCK M14
4	043768A	1	SOLENOID GAS FUEL	21	051779	2	NUT HEX M14-2 G8 YEL CHR
5	026490	1	NIPPLE PIPE 3/4 NPT X 2	22*	055934P	1	CLAMP VINYL 1.62 X .486 Z
6	026577	2	BUSHING REDUCER 1 TO 3/4	23	027482	1	WASHER SHAKEPROOF EXT 5/16 STL
7	0D2758	1	REGULATOR N/G (R600S)	24	0C3168	1	WASHER LOCK SPECIAL 5/16
8	028237	2	SADDLE 1-3/8	25	022259	5	NUT HEX 5/16-18 STEEL
9	0C2775	1	BRACKET REGULATOR 4.3L	26	058359	1	LUG RNGTNG INS
10	028238	2	BOLT U 5/16-18 X 1.50	27	0D2616	1	SUPPORT REGULATOR
11	022145	10	WASHER FLAT 5/16 ZINC	28	0D1509	1	DECAL,INLET PRESSURE
12	022129	10	WASHER LOCK M8-5/16				
13	030795	4	SCREW HHC 5/16-18 X 1 G5				
14	025655	1	PLUG STD PIPE 3/4 STEEL SQ HD				
15	022132	2	WASHER FLAT 9/16 ZINC				
16	051778	2	SCREW HHC M14-2.0 X 25 G8.8				
17	028641	1	NIPPLE TOE 3/4 NPT X 2				

* NOT SHOWN

NOTE: ITEM #22 ATTACHES TO ALTERNATOR SCROLL

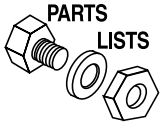

Section 7 — Exploded Views and Parts Lists

(Model Nos. 004373-1 & 004626-0) Guardian Liquid-cooled 40 kW Generators
 Engine Coolant Heater – Drawing No. 087434-D

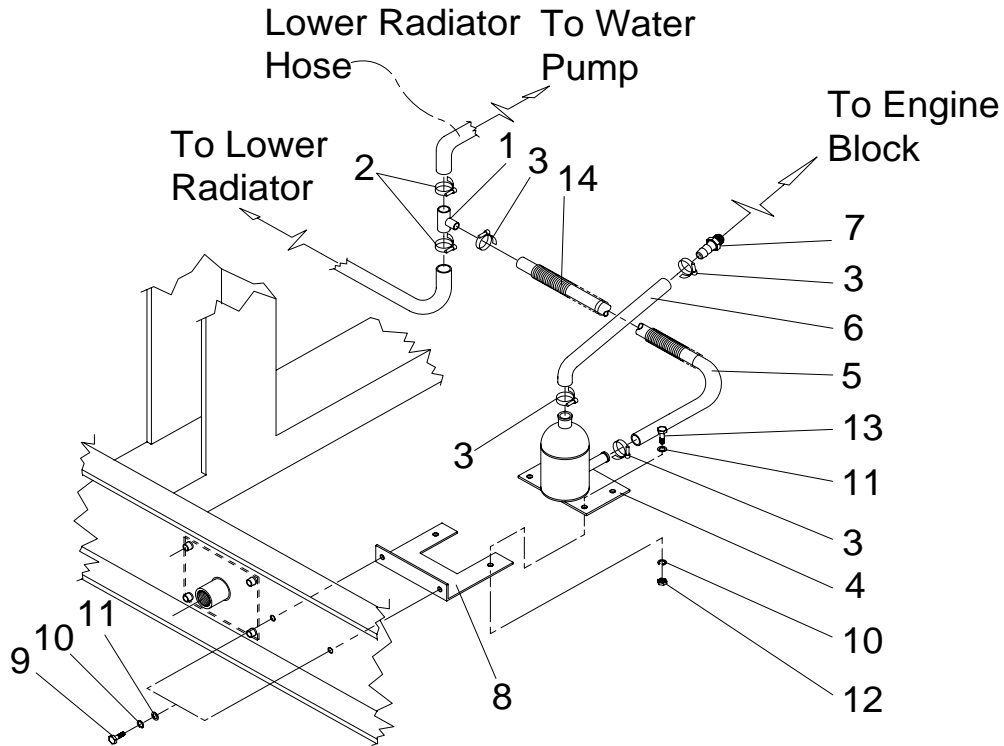

ITEM	PART NO.	QTY.	DESCRIPTION
------	----------	------	-------------

1	080723	1	HOSE CONNECTION TEE 1.75-.62
2	035685	2	CLAMP, HOSE #28 1.32-2.25
3	057822	4	CLAMP, HOSE #8 .53-1.00
4	084918C	1	HEATER, ENGINE 1800W 120V.
	*084918D	1	HEATER, ENGINE 2000W 240V.
5	050967	1	HOSE, 5/8" I.D. RIA 250F (36")
6	0A6283	1	HOSE, PREFORMED BLOCK HEATER
7	053660	1	BARBED ST. 1/4" NPT x 5/8 I.D.
8	084427	1	BRACKET, HEATER
9	047411	2	SCREW HHC M6-1.0 X 16 G8.8
10	022097	4	WASHER, LOCK-M6-1/4
11	022473	4	WASHER, FLAT 1/4 ZINC
12	049813	2	NUT, HEX-M6 X 1.00 G8 YEL CHR
13	042568	2	SCREW, HHC-M6-1.0 x 20MM G8.8
14	**077043E	36"	FLEXIBLE CONDUIT 1" BLACK

*USED ON "R" VOLTAGE GENERATORS ONLY

**ITEM #14 USED ONLY ON 4.3L UNITS

Section 7 – Exploded Views and Parts Lists
 (Model Nos. 004373-1 & 004626-0) Guardian Liquid-cooled 40 kW Generators
 Battery – Drawing No. A6708-F

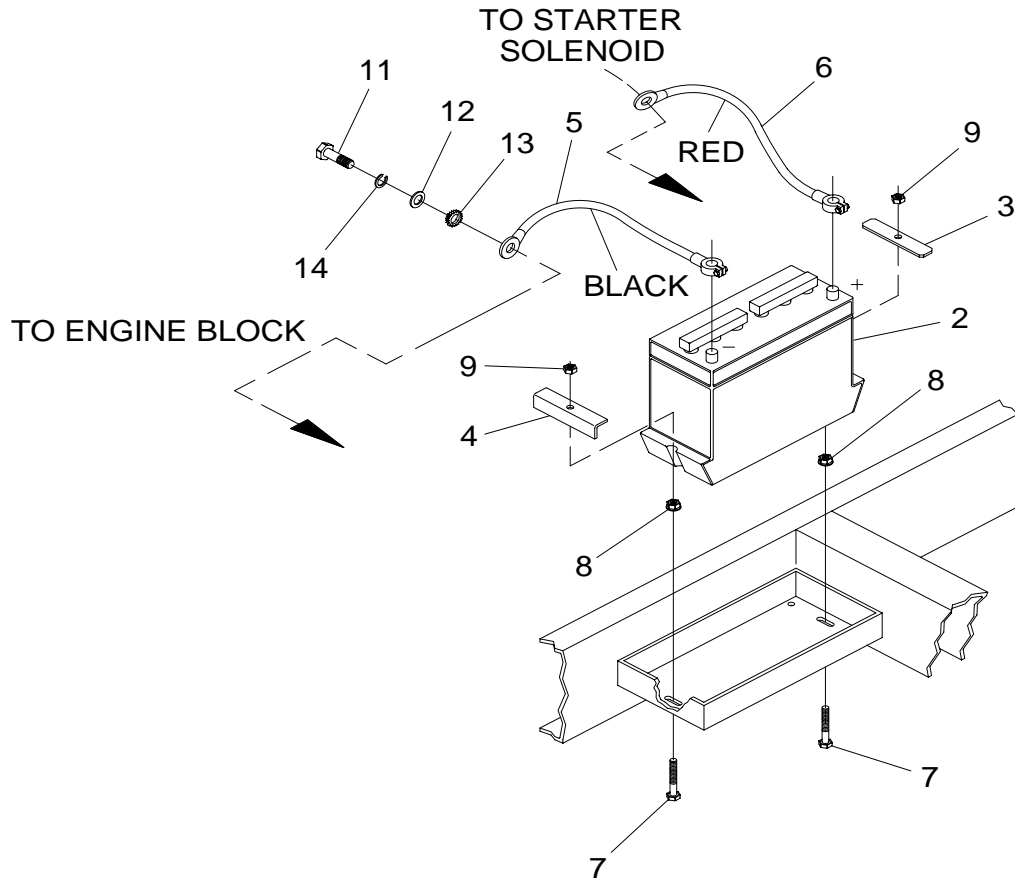
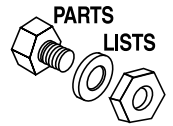

ITEM	PART NO.	QTY.	DESCRIPTION
2	058665	1	BATTERY 12VDC 90-AH 27F (OPTIONAL)
3	061902	1	HOLD DOWN BATTERY
4	059473	1	HOLD DOWN BATTERY
5	038805H	1	CABLE BATTERY BLACK #1 X 23.00
6	038804N	1	CABLE BATTERY RED #1 X 15.00
	038804T	1	CABLE BATTERY RED #1 X 31.00 (GEAR BOX-NON-GUARDIAN UNITS)
7	0A4010	2	SCREW HHC M8-1.25 X 60 FT G8.8
8	052858	2	NUT LOCK FLANGE M8-1.25
9	049820	2	NUT LOCK HEX M8-1.25 (NYLON INSERT)
11	023152	1	SCREW HHC 3/8-16 X 3/4 G5
12	022131	1	WASHER FLAT M10-3/8 ZINC
13	025507	1	WASHER SHAKEPROOF EXT 7/16 STL
14	022237	1	WASHER LOCK 3/8



Section 7 – Exploded Views and Parts Lists

(Model Nos. 004373-1 & 004626-0) Guardian Liquid-cooled 40 kW Generators
Lower Panel – Drawing No. 0D5334-B

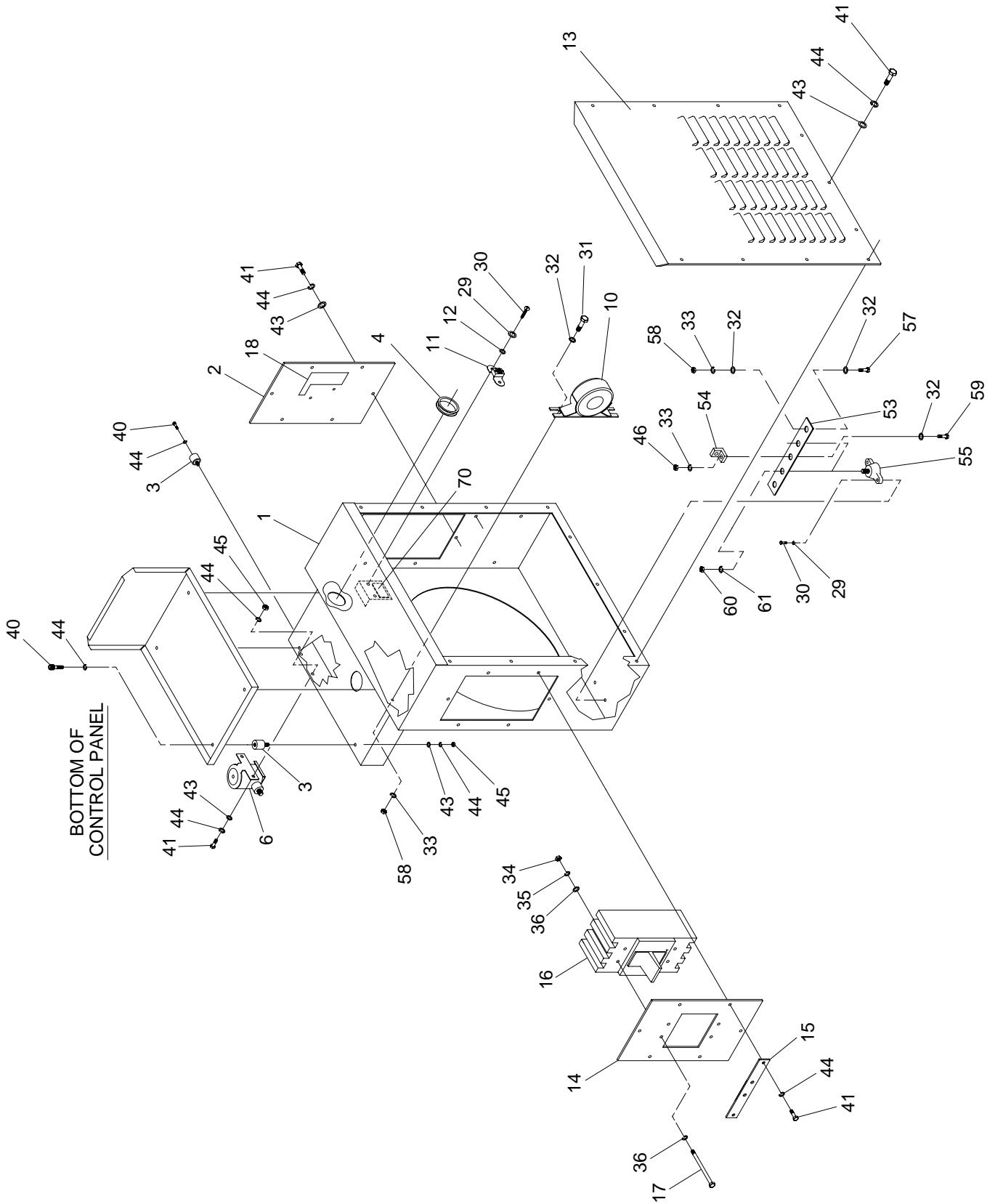

Section 7 – Exploded Views and Parts Lists

(Model Nos. 004373-1 & 004626-0) Guardian Liquid-cooled 40 kW Generators
Lower Panel – Drawing No. 0D5334-B

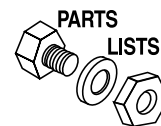

ITEM	PART NO.	QTY.	DESCRIPTION	ITEM	PART NO.	QTY.	DESCRIPTION
1	068115	1	LOWER PANEL 15	35	022152	14	WASHER LOCK #10
2	0D5489	1	COVER LOWER CONNECTION BOX	36	023897	8	WASHER FLAT #10 ZINC
3	040479	4	VIBRATION MOUNT 1.0 X 1.0 X 1/4-20	37	069232	4	SCREW RHM #10-32 X 3-3/4
4	023484N	1	BUSHING SNAP SB-2.5-31	39	022471	7	NUT HEX #8-32 STEEL
6	056739	1	RELAY SOLENOID 12VDC PNL MNT	40	022507	8	SCREW HHC 1/4-20 X 1/2 G5
10	058710	2	TRANSFORMER 200A TO 5A 5VA	41	022287	27	SCREW HHC 1/4-20 X 3/4 G5
11	048766	1	BLOCK TERM 20A 2 X 6 X 1100V	43	022473	19	WASHER FLAT 1/4 ZINC
12	022985	2	WASHER FLAT #6 ZINC	44	022097	50	WASHER LOCK M6-1/4
13	068116	1	COVER LOWER PANEL 15	45	022127	12	NUT HEX 1/4-20 STEEL
14	081418	1	COVER-CB KAP36000 15"	46	022259	6	NUT HEX 5/16-18 STEEL
15	081419	1	COVER-CB TERM KAP 15"	53	069173	1	BUS BAR NEUTRAL STRP
16	081523U	1	CIRCT BRK 200 X 3 600V UL SQ D	54	057329	1	LUG SLDLSS 350-#6 X 13/32 AL/CU
17	042419	4	SCREW RHM 10-32 X 4		062684	1	LUG SLDLSS 2/0-#12 X 11/32 CU
18	0D5840	1	DECAL CUSTOMER CONNECTN FOR TS	55	057073	2	JUNCTION BLOCK 3/8-16
29	022264	13	WASHER LOCK M4	57	039287	2	SCREW HHC M8-1.25 X 45 G8.8
30	0C2212	4	SCREW PHTT M4-0.7 X 16 ZYC	58	045771	2	NUT HEX M8-1.25 G8 YEL CHR
31	022142	6	SCREW HHC 5/16-18 X 3/4 G5	59	022511	1	SCREW HHC 3/8-16 X 1-1/4 G5
32	022145	8	WASHER FLAT 5/16 ZINC	60	022241	3	NUT HEX 3/8-16 STEEL
33	022129	12	WASHER LOCK M8-5/16	61	022237	3	WASHER LOCK 3/8
34	022158	10	NUT HEX #10-32 STEEL	70	0D3388	1	DECAL REMOTE START CONNECTION

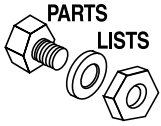

Section 7 – Exploded Views and Parts Lists

(Model No 004626-0) Guardian Liquid-cooled 40 kW Generators
 Exhaust Muffler – Drawing No. 0D6976

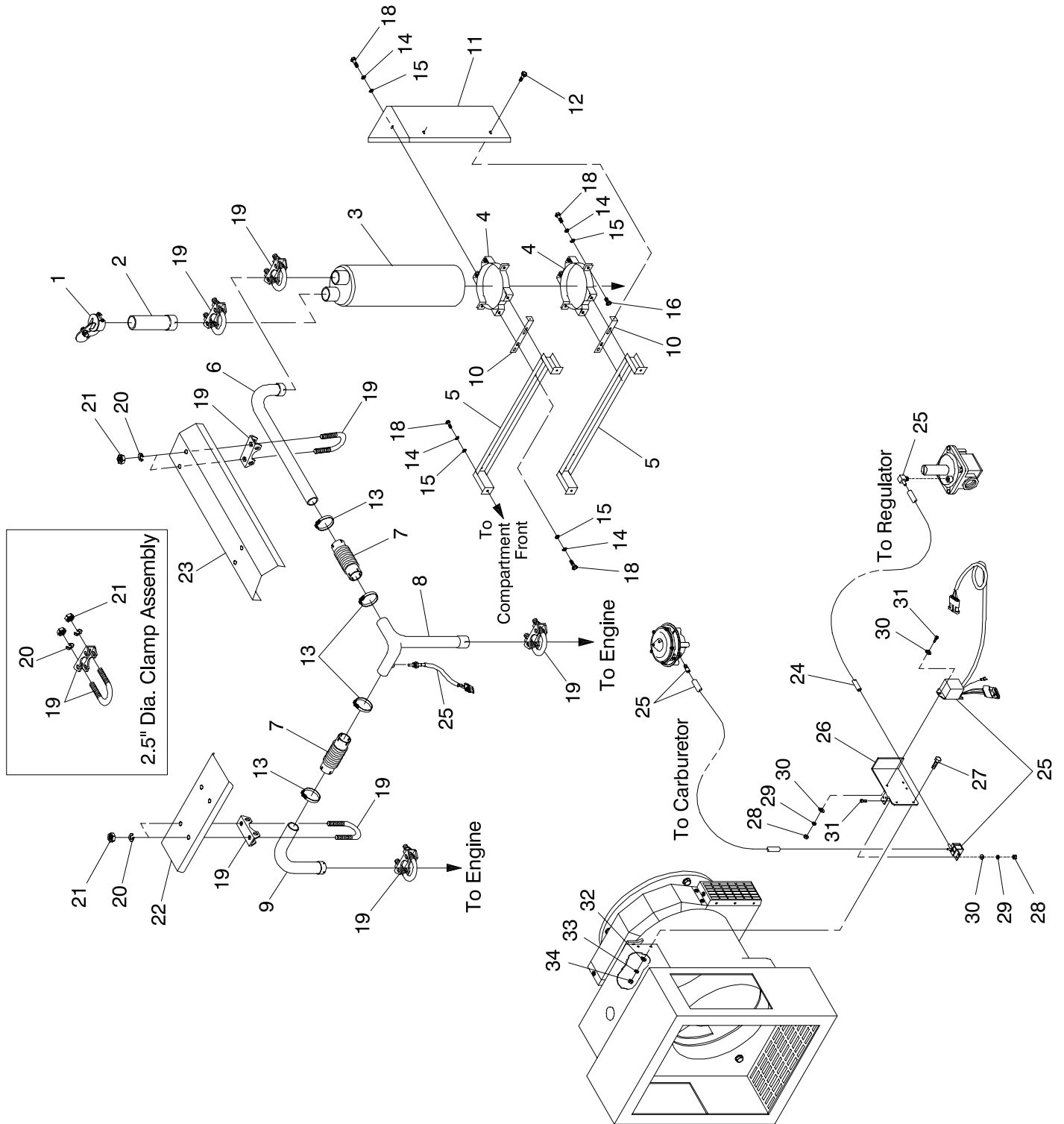

Section 7 – Exploded Views and Parts Lists

**(Model No 004626-0) Guardian Liquid-cooled 40 kW Generators
Exhaust Muffler – Drawing No. 0D6976**

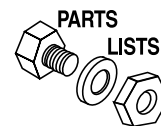

ITEM	PART NO.	QTY.	DESCRIPTION	ITEM	PART NO.	QTY.	DESCRIPTION
1	059902A	1	CAP RAIN 2.50 / 2.69	19	080762	8	BOLT U 3/8-16 X 2.62
2	0C9641	1	TUBE STRAIGHT 'A' GROUP	20	022237	16	WASHER LOCK 3/8
3	0D4208	1	MUFFLER CATALYST 4.3L	21	022241	16	NUT HEX 3/8-16 STEEL
4	0D5061	4	MOUNTING BAND A-GRP CATALYST	22	0D5187	1	SHIELD HEAT CROSSOVER 4.3L
5	0C4126	2	BRACKET MUFFLER MOUNTING	23	0D5190	1	SHIELD HEAT EXHAUST 4.3L
6	0D5787	1	TUBE ELBOW 90 DEG 2.5"	24	077879	1	HOSE VACUUM 5/32 (3')
7	0A5215B	2	PIPE FLEX 2.5"	25	0D4221	1	KIT AIR/FUEL RATIO CONTROLLER
8	0D5792	1	TUBE 2.5" SMALL TEE	26	0D4512	1	BRACKET AIR/FUEL CONTROLLER
9	0D5793	1	TUBE ELBOW 90 DEG 2.5" FLARED	27	043116	2	SCREW HHC M6-1.0 X 12 G8.8
10	0C4170	2	BRACKET EXHAUST SHIELD	28	022471	5	NUT HEX #8-32 STEEL
11	0C4305	1	SHIELD A-GRP HEAT	29	022264	5	WASHER LOCK #8-M4
12	0C2454	2	SCREW TH-FRM M6-1 X 16 N WA Z/J5	30	038150	8	WASHER FLAT #8 ZINC
13	0C3433A	4	CLAMP BAND 2.5"	31	036918	5	SCREW PPHM #8-32 X 1/2
14	022129	16	WASHER LOCK M8-5/16	32	049811	2	WASHER FLAT M6
15	022145	20	WASHER FLAT 5/16 ZINC	33	022097	2	WASHER LOCK M6-1/4
16	045771	4	NUT HEX M8-1.25 G8 YEL CHR	34	049813	2	NUT HEX M6 X 1.0 G8 YEL CHR
18	042907	16	SCREW HHC M8-1.25 X 16 G8.8				

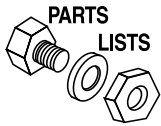

Section 7 — Exploded Views and Parts Lists

(Model No. 004373-1) Guardian Liquid-cooled 40 kW Generators
Generator – Drawing No. 0D5786

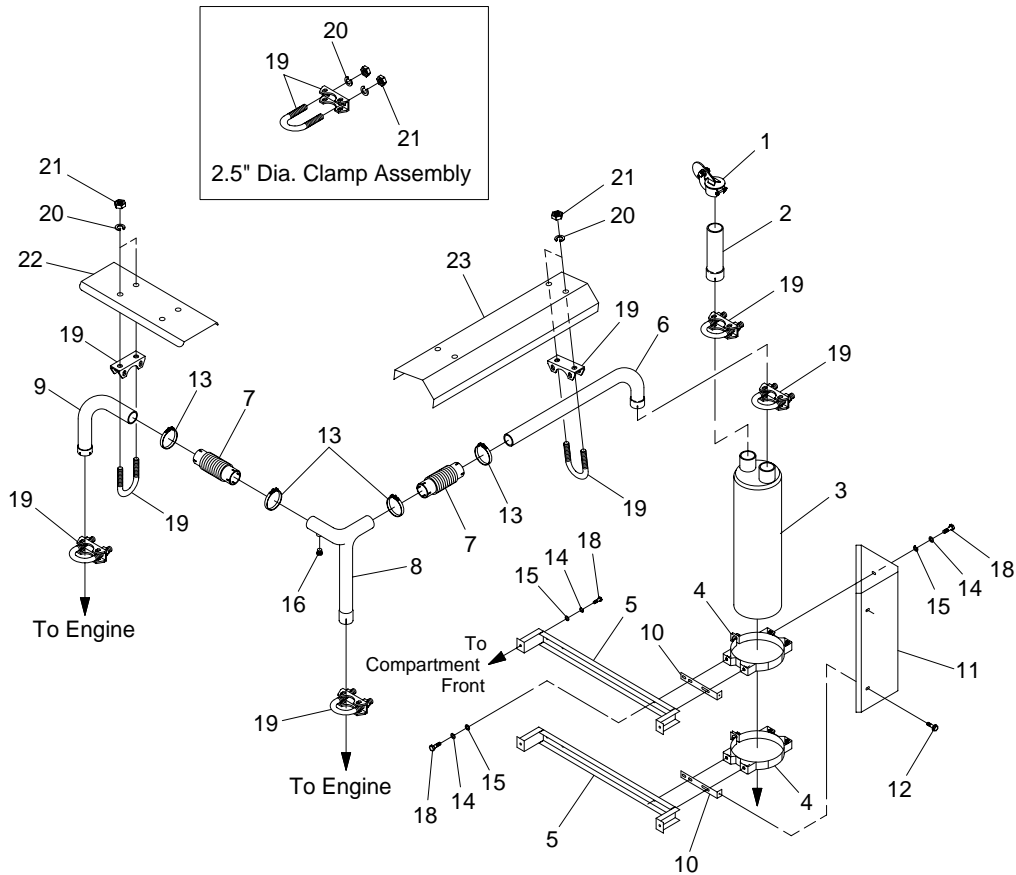

ITEM	PART NO.	QTY.	DESCRIPTION	ITEM	PART NO.	QTY.	DESCRIPTION
1	059902A	1	CAP RAIN 2.50 / 2.69	12	0C2454	2	SCREW TH-FRM M6-1 X 16 N WA Z/JS
2	0C9641	1	TUBE STRAIGHT 'A' GROUP	13	0C3433A	4	CLAMP BAND 2.5"
3	0C9650	1	MUFFLER 2-1/2" INLET/OUTLET	14	022129	12	WASHER LOCK M8-5/16
4	0C4114A	2	CLAMP BAND MUFFLER 6.5"	15	022145	12	WASHER FLAT 5/16 ZINC
5	0C4126	2	BRACKET MUFFLER MOUNTING	16	0C9748	1	PLUG M18-1.5
6	0D5787	1	TUBE ELBOW 90 DEG 2.5"	18	042907	12	SCREW HHC M8-1.25 X 16 G8.8
7	0A5215B	2	PIPE FLEX 2.5"	19	080762	8	BOLT U 3/8-16 X 2.62
8	0D5792	1	TUBE 2.5" SMALL TEE	20	022237	16	WASHER LOCK 3/8
9	0D5793	1	TUBE ELBOW 90 DEG 2.5" FLARED	21	022241	16	NUT HEX 3/8-16 STEEL
10	0C4170	2	BRACKET EXHAUST SHIELD	22	0D5187	1	SHIELD HEAT CROSSOVER 4.3L
11	0C4305	1	SHIELD A-GRP HEAT	23	0D5190	1	SHIELD HEAT EXHAUST 4.3L

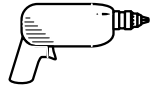

Section 9 – Installation Drawings

Guardian Liquid-cooled 40 kW Generators
Installation Drawing – Drawing No. OD5335

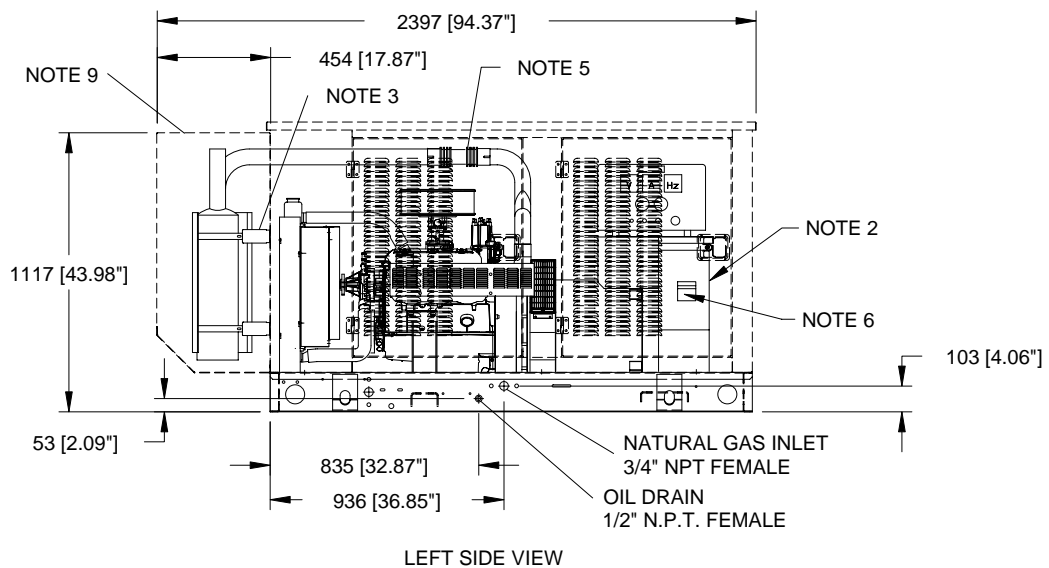
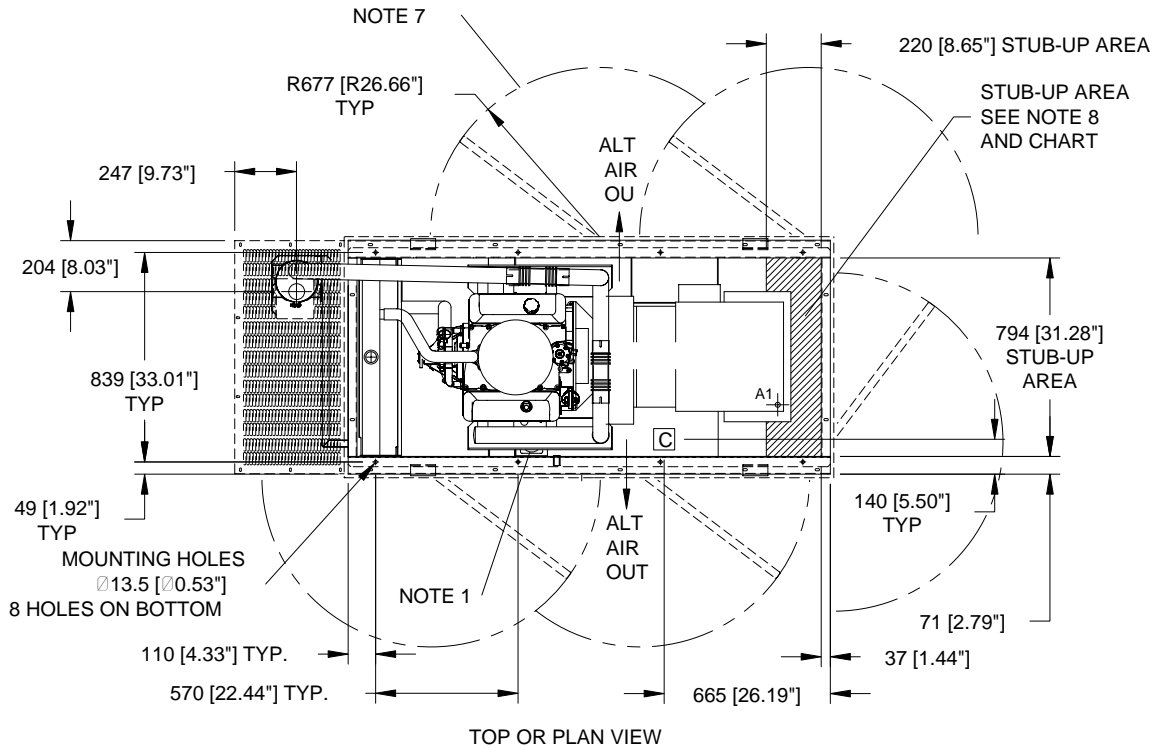

Section 9 – Installation Drawings
Guardian Liquid-cooled 40 kW Generators
Installation Drawing – Drawing No. 0D5335

INSTALLATION

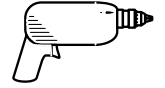

RECOMMENDED FUEL/ELECTRICAL STUB-UPS (SEE TOP VIEW)	
DESCRIPTION	INSIDE BASE
AC LOAD LEAD CONDUIT (LEFT)	A1
INSIDE STUB-UP FOR FUEL CONNECTIONS	C

NOTE:
 FUEL SYSTEM SET UP WITH OUTSIDE STUB UPS (SEE LEFT SIDE VIEW). SMALL FUEL SYSTEM MODIFICATIONS REQUIRED FOR INSIDE STUB-UPS.

NOTES:

- STANDARD BLOCK HEATER REQUIRES 120V AC CONNECTION
- CONNECTION POINTS FOR AC LOAD LEADS, TRANSFER SWITCH, AND ENGINE AUTOMATIC START/STOP CONTROL WIRES PROVIDED IN AC CONNECTION PANEL.
- EXHAUST MUFFLER SUPPORT BRACKETS SUPPLIED WITH OPTIONAL COMPARTMENT.
- 12 VOLT NEGATIVE GROUND SYSTEM
 BATTERY TRAY INSIDE DIMENSIONS: 178 X 342.5 [7" X 13.5"]
- 2.5" I.D. FLEX EXHAUST
- MAIN LINE CIRCUIT BREAKER.
- DOORS MUST BE OPENED 90 DEG. TO BE REMOVED.
- A1 MAY BE USED FOR CIRCUIT BREAKER STUB-UP LOCATION.
- SEE DRAWING C3850 FOR DUCT REMOVAL. REMOVAL OF FRONT DUCT WILL PROVIDE ACCESS TO MUFFLER FOR SERVICING.

WEIGHT DATA

UNIT: 729.7 kg [1609 lbs]
 STEEL COMPARTMENT: 208.6 kg [460 lbs]

UNITS: mm [INCHES]

ENGINE SERVICE CONNECTIONS

INLET NATURAL GAS = 3/4" NPT COUPLING
 OIL DRAIN = 1/2" NPT COUPLING
 EXHAUST OUTLET - 2.5" OD MUFFLER OUTLET

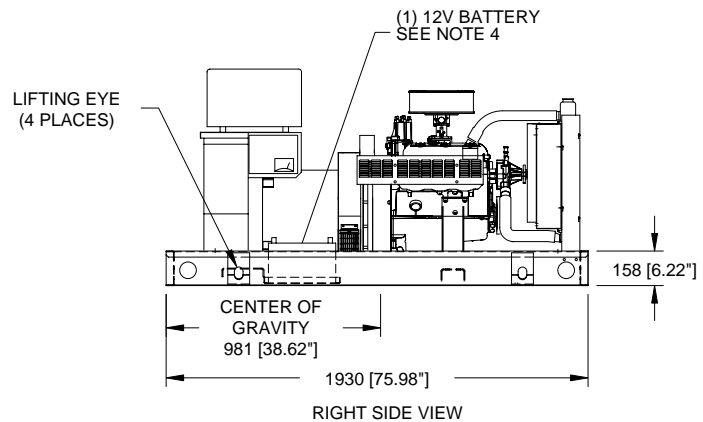
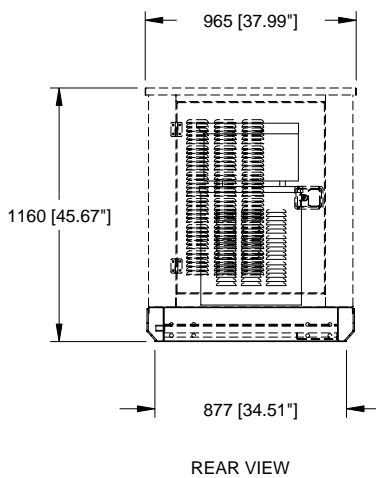



Section 10 – Warranty

Guardian Liquid-cooled 40 kW Generators

GENERAC POWER SYSTEMS "TWO YEAR" STANDARD WARRANTY FOR GUARDIAN® "PREPACKAGED EMERGENCY AUTOMATIC STANDBY GENERATORS"

For a period of two years or 2000 hours of operation from the date of original sale, whichever occurs first, Generac Power Systems, Inc. (Generac) will, at its option, repair or replace any part which, upon examination, inspection and testing by Generac or a Generac Authorized Warranty Service Dealer, is found to be defective under normal use and service, in accordance with the warranty schedule set forth below. Any equipment that the purchaser/owner claims to be defective must be returned to and examined by the nearest Generac Authorized Warranty Service Dealer. All transportation costs under the warranty, including return to the factory, are to be borne and prepaid by the purchaser/owner. This warranty applies only to Generac Guardian prepackaged emergency automatic standby generators sold and rated for use in "Standby" applications.

WARRANTY SCHEDULE

YEARS ONE and TWO - 100% (one hundred percent) transferable coverage on Labor and Part(s) listed (proof of purchase and maintenance is required):

- Engine - All Components
- Alternator - All Components
- Transfer System - All Components

All warranty expense allowances are subject to the conditions defined in Generac's Warranty Policies, Procedures and Flat Rate Manual.

THIS WARRANTY SHALL NOT APPLY TO THE FOLLOWING:

- Generac Guardian generators that utilize non-Generac replacement parts.
- Any Generac Guardian generators used as rental or trailer mounted applications.
- Units used for prime power in place of existing utility power where utility power is present or in place of utility power where utility power service does not normally exist.
- Costs of normal maintenance, adjustments, installation and start-up.
- Failures caused by any contaminated fuels, oils, coolants or lack of proper fluid amounts.
- Failures due, but not limited, to normal wear and tear, accident, misuse, abuse, negligence or improper installation. As with all mechanical devices, the Generac engines need periodic part(s) service and replacement to perform well. This warranty will not cover repair when normal use has exhausted the life of a part(s) or engine.
- Failures caused by any external cause or act of God, such as collision, theft, vandalism, riot or wars, nuclear holocaust, fire, freezing, lightning, earthquake, windstorm, hail, volcanic eruption, water or flood, tornado or hurricane.
- Damage related to rodent infestation.
- Products that are modified or altered in a manner not authorized by Generac in writing.
- Any incidental, consequential or indirect damages caused by defects in materials or workmanship, or any delay in repair or replacement of the defective part(s).
- Failure due to misapplication.
- Telephone, cellular phone, facsimile, internet access or other communication expenses.
- Living or travel expenses of person(s) performing service, except as specifically included within the terms of a specific unit warranty period.
- Expenses related to "customer instruction" or troubleshooting where no manufacturing defect is found.
- Rental equipment used while warranty repairs are being performed.
- Overnight freight costs for replacement part(s).
- Overtime labor.
- Starting batteries, fuses, light bulbs and engine fluids.

THIS WARRANTY IS IN PLACE OF ALL OTHER WARRANTIES, EXPRESSED OR IMPLIED. SPECIFICALLY, GENERAC MAKES NO OTHER WARRANTIES AS TO THE MERCHANTABILITY OR FITNESS FOR A PARTICULAR PURPOSE. Some states do not allow limitations on how long an implied warranty lasts, so the above limitation may not apply to you.

GENERAC'S ONLY LIABILITY SHALL BE THE REPAIR OR REPLACEMENT OF PART(S) AS STATED ABOVE. IN NO EVENT SHALL GENERAC BE LIABLE FOR ANY INCIDENTAL OR CONSEQUENTIAL DAMAGES, EVEN IF SUCH DAMAGES ARE A DIRECT RESULT OF GENERAC'S NEGLIGENCE. Some states do not allow the exclusion or limitation of incidental or consequential damages, so the above limitation may not apply to you.

This warranty gives you specific legal rights. You also have other rights from state to state.

GENERAC® POWER SYSTEMS, INC.

P.O. BOX 297

WHITEWATER, WI 53190

Free Manuals Download Website

<http://myh66.com>

<http://usermanuals.us>

<http://www.somanuals.com>

<http://www.4manuals.cc>

<http://www.manual-lib.com>

<http://www.404manual.com>

<http://www.luxmanual.com>

<http://aubethermostatmanual.com>

Golf course search by state

<http://golfingnear.com>

Email search by domain

<http://emailbydomain.com>

Auto manuals search

<http://auto.somanuals.com>

TV manuals search

<http://tv.somanuals.com>