

GENERAC

The Reliable Ones

5500EXL

Portable Generator Owner's Manual

! **DANGER!** This generator is designed for outdoor use only. **Never** use this generator inside any building or enclosure including the generator compartment of a recreational vehicle (RV). **Carbon monoxide poisoning, fire and/or an explosion may result.** No user performed modifications, including venting of exhaust and/or cooling ventilation, will eliminate the danger. Always have at least two feet of clearance on all sides of the generator even while operating the unit outdoors.

! **DANGER!** You must isolate the generator from the electric utility by opening the electrical system's main circuit breaker or main switch if this unit is used for backup power. **Failure to isolate the generator from the power utility may result in injury or death to electric utility workers and damage to the generator** due to a backfeed of electrical energy.

The Emission Control System for this generator is warranted for standards set by the Environmental Protection Agency. For warranty information refer to the engine owner's manual.

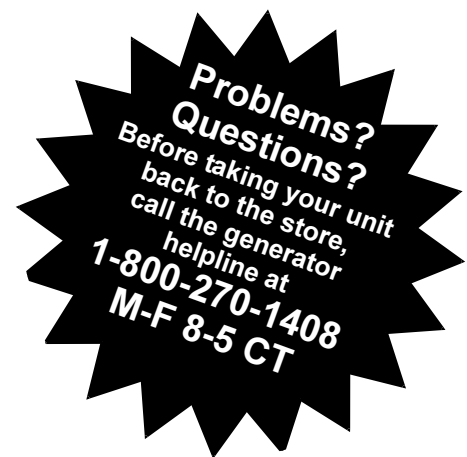

Model No. 9797-3 (5500 Watt AC Generator) Manual No. 20820 Revision 3 (2/17/2000)

Visit our Generac website: www.generac-portables.com

! This is the safety alert symbol. It is used to alert you to potential personal injury hazards. Obey all safety messages that follow this symbol to avoid possible injury or death.



EQUIPMENT DESCRIPTION

This generator is an engine-driven, revolving field, alternating current (AC) generator. It was designed to supply electrical power for operating compatible electrical lighting, appliance, tool and motor loads.

This manual contains information for a generator that operates 120 and/or 240 Volt AC, single phase, 60Hz devices that require up to 5,500 watts (5.5 kW) of power that pull up to 45.8 Amps at 120 Volts or 22.9 Amps at 240 Volts.

CAUTION: Do Not exceed the generator's wattage/ampere capacity. Add up the rated watts of all devices you will connect to generator receptacles at one time. This total should not be greater than 5,500 watts for this generator. Review "Don't Overload the Generator" on page 11.

The generator's revolving field is driven at about 3600 rpm by a single-cylinder engine.

Every effort has been made to ensure that information in this manual is accurate and current. However, Generac reserves the right to change, alter or otherwise improve the product and this document at any time without prior notice.

DANGER: Do Not tamper with engine governed speed. High operating speeds are dangerous and increase the risk of personal injury or damage to equipment. The unit supplies correctly rated frequency and voltage only when running at proper governed speed. Incorrect frequency and/or voltage can damage some connected electrical loads. Operating at excessively low speeds imposes a heavy load on the engine, and may shorten engine life.

SAFETY RULES

This generator set was designed and manufactured for specific applications. **Do Not** attempt to modify the unit or use it for any application it was not designed for. If you have any questions about your generator's application, ask your dealer or consult the factory.

The manufacturer could not possibly anticipate every circumstance that might involve a hazard. For that reason, warnings in the manual and warnings on tags or decals affixed to the unit are not all-inclusive. If you intend to handle, operate or service this unit by a procedure or method not specifically recommended by the manufacturer, first make sure the procedure or method will not render this equipment unsafe or pose a threat to you and others.

Read this manual carefully and become familiar with your generator set. Know its applications, its limitations and any hazards involved.

WARNING:
The engine exhaust from this product contains chemicals known to the State of California to cause cancer, birth defects, or other reproductive harm.

- The generator produces a very powerful voltage that can cause extremely dangerous electrical shock. Avoid contact with bare wires, terminals, etc. Never permit any unqualified person to operate or service the generator.
- Never handle any kind of electrical cord or device while standing in water, while barefoot or while hands or feet are wet.
- The National Electric Code requires the frame and external electrically conductive parts of the unit to be properly connected to an approved earth ground. Local electrical codes may also require proper grounding of the generator. Consult with a local electrician for requirements in your area.
- Use a ground fault circuit interrupter in any damp or highly conductive area (such as metal decking or steel work).



- **Do Not** use worn, bare, frayed or otherwise damaged electrical cord sets with the generator.
- Operate the generator only on level surfaces and where it will not be exposed to excessive moisture, dirt, dust or corrosive vapors.
- Gasoline is highly **FLAMMABLE** and its vapors are **EXPLOSIVE**. **Do Not** permit smoking, open flames, sparks or heat in the vicinity while handling gasoline. Avoid spilling gasoline on a hot engine. Comply with all regulations requiring storage and handling of gasoline.
- **Do Not** overfill the fuel tank. If overfilled, fuel can contact the hot engine and cause **FIRE** or an **EXPLOSION**.
- Never store the generator with fuel in its tank where gasoline vapors might reach an open flame, spark or pilot light (as on a furnace, water heater or clothes dryer). **FIRE** or **EXPLOSION** might result.
- Generator exhaust gases contain **DEADLY** carbon monoxide gas. This dangerous gas, if breathed in sufficient concentrations, can cause unconsciousness or even death. Operate this equipment only in the open air where adequate ventilation is available.
- The unit requires an adequate flow of cooling air for its continued proper operation. Never operate the unit inside any room or enclosure where the free flow of cooling air into and out of the unit might be obstructed. Without sufficient cooling air flow, the unit quickly overheats, damaging the generator or nearby property.
- Allow at least 2 feet of clearance on all sides of the generator or you could damage the unit. Review "Cold Weather Operation" on page 8.
- Never start or stop the unit with electrical loads connected to receptacles **AND** with the connected devices turned **ON**. Start the engine and let it stabilize before connecting electrical loads. Disconnect all electrical loads before shutting the unit down.
- **Do Not** insert any object through the unit's cooling slots. You could damage the unit or injure yourself.

- **Never operate this generator:** in rain; in any enclosed compartment; when connected electrical devices overheat; if electrical output is lost; if engine or generator sparks; if flame or smoke is observed while running; if unit vibrates excessively.

GROUNDING THE GENERATOR

The National Electric Code requires the frame and external electrically conductive parts of generator be properly connected to approved earth ground.

Local electrical codes may also require proper grounding of this unit. For that purpose, a **GROUNDING WING NUT** (Figure 1) is provided on the frame of your unit.

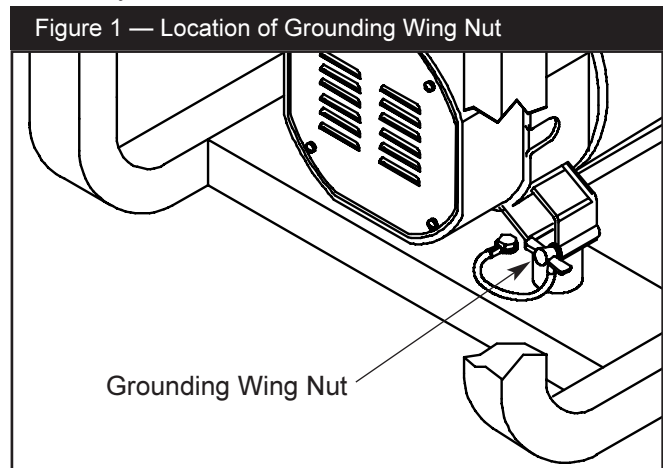

Generally, connecting a No. 12 AWG (American Wire Gauge) stranded copper wire to the grounding wing nut and to an earth-driven copper or brass grounding rod (electrode) provides adequate protection against electrical shock.

However, local codes may vary widely. Consult with a local electrician for grounding requirements in your area. Be sure to keep the ground wire attached while you connect the electrode.

Properly grounding the generator helps prevent electrical shock if a ground fault condition exists in the generator or in connected electrical devices. Proper grounding also helps to dissipate the static electricity which may build up in ungrounded devices.



KNOW YOUR GENERATOR

Read this owner's manual and safety rules before operating your generator.

Compare the illustrations with your generator to familiarize yourself with the locations of various controls and adjustments. Save this manual for future reference.

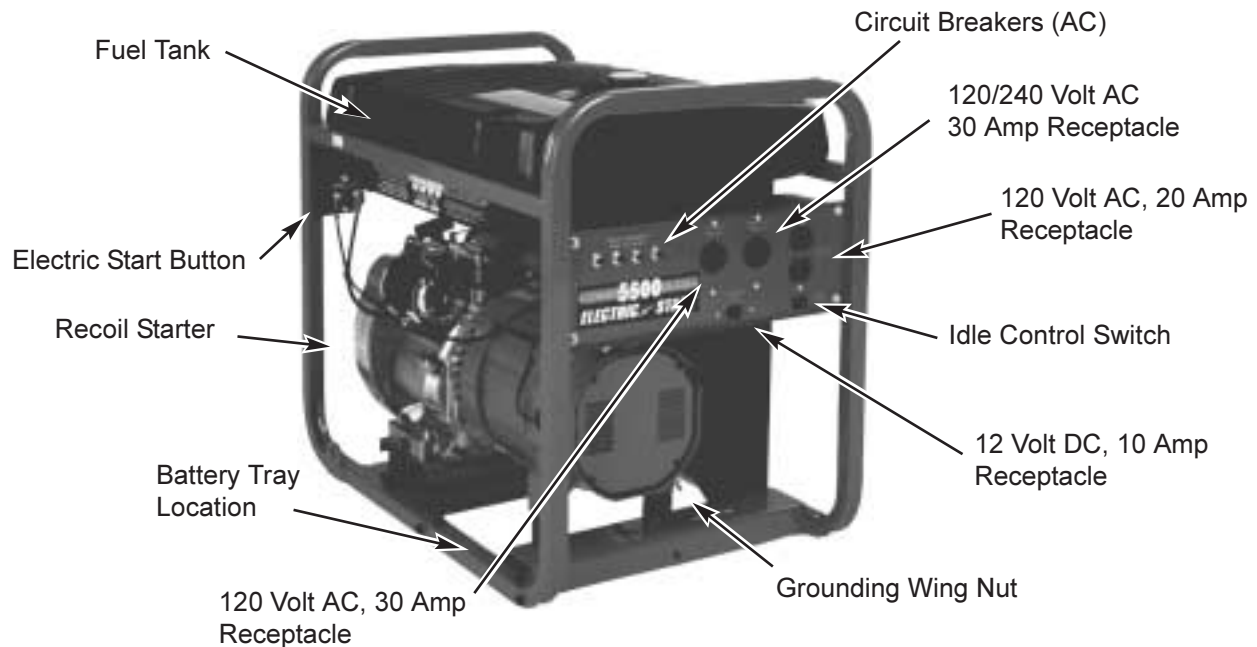

12 Volt DC, 10 Amp Receptacle — Used with battery charge cables to charge a 12 Volt battery.

120 Volt AC, 20 Amp Receptacles — May be used to supply electrical power for the operation of 120 Volt AC, single phase, 60 Hz electrical lighting, appliance, tool and motor loads.

120 Volt AC, 30 Amp Receptacle — May be used to supply electrical power for the operation of 120 Volt AC, 30 Amp, single phase, 60 Hz electrical lighting, appliance, tool and motor loads.

120/240 Volt AC, 30 Amp Receptacle — May be used to supply electrical power for the operation of 120 and/or 240 Volt AC, 30 Amp, single phase, 60 Hz electrical lighting, appliance, tool and motor loads.

Battery Tray Location — Pre-tapped and installed screws are found here for the battery tray

Circuit Breakers (AC) — Each receptacle is provided with a "push to reset" circuit breaker to protect the generator against electrical overload.

Electric Start Button — Press to start unit.

Fuel Tank — Capacity of seven U.S. gallons of unleaded fuel.

Grounding Wing Nut— Use this connection to properly ground the generator.

Idle Control Switch — The idle control runs the engine at normal (high) speeds when there is a load present and runs the engine at idle (low) speeds when a load is not present.

Recoil Starter — Used as an alternate method of starting the unit.

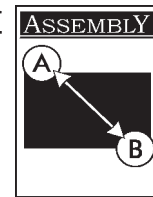

Your generator requires some assembly and is ready for use after it has been properly serviced with the recommended oil and fuel.

If you have any problems with the assembly of your generator, please call the generator helpline at 1-800-270-1408.

IMPORTANT: Any attempt to run the unit before it has been serviced with the recommended oil will result in an engine failure.

REMOVE GENERATOR FROM CARTON

- Set the carton on a rigid flat surface with “This Side Up” arrows pointing upward.
- Carefully open the top flaps of the shipping carton (review “Cold Weather Operation” on page 8).
- Cut down corners at one end of carton from top to bottom and lay that side of carton down flat.
- Remove all packing material, carton fillers, etc.
- Remove the generator from the shipping carton.

CARTON CONTENTS

Check all contents. If any parts are missing or damaged, call the generator helpline at **1-800-270-1408**.

- The generator
- Electric start battery cables
- Generator and engine owner’s manuals
- Locking 20 Amp and 30 Amp plugs
- Battery charge cables
- Battery tray mounting bracket/hardware
- Spare spark plug and air filter element
- Spark plug wrench

INSTALLING TRAY AND BATTERY

You must purchase and install a 12 Volt DC battery (Series U1-109). The battery should be serviced with electrolyte fluid and fully charged prior to installation.

Install the battery as follows:

- Find battery tray and fasteners (loose) in carton. Includes all parts needed to mount battery and tray.
- Remove the 4 battery tray screws from cradle.
- Position the battery tray and install (Figure 2).

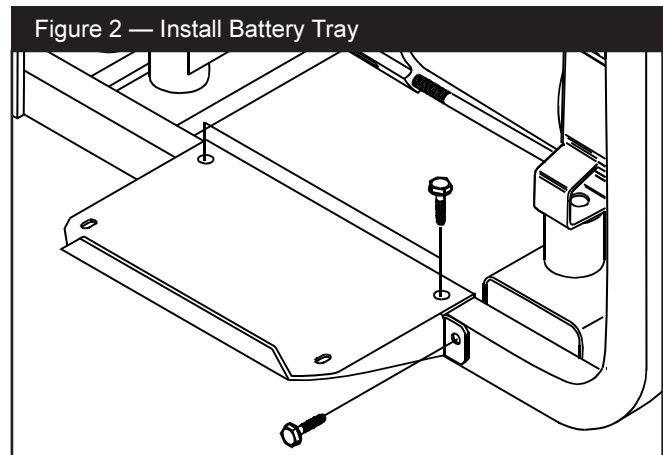

- Set battery onto tray (Figure 3).

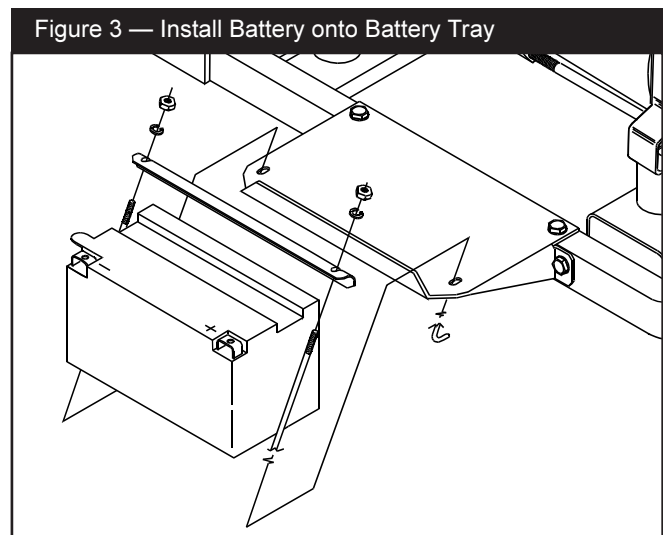

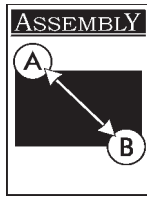

- Retain battery to tray with 2 J-bolts, 2 lock washers and 2 hex nuts (Figure 3).
- Connect the red battery cable from the engine start button to the **positive (+)** terminal on battery (Figure 4).

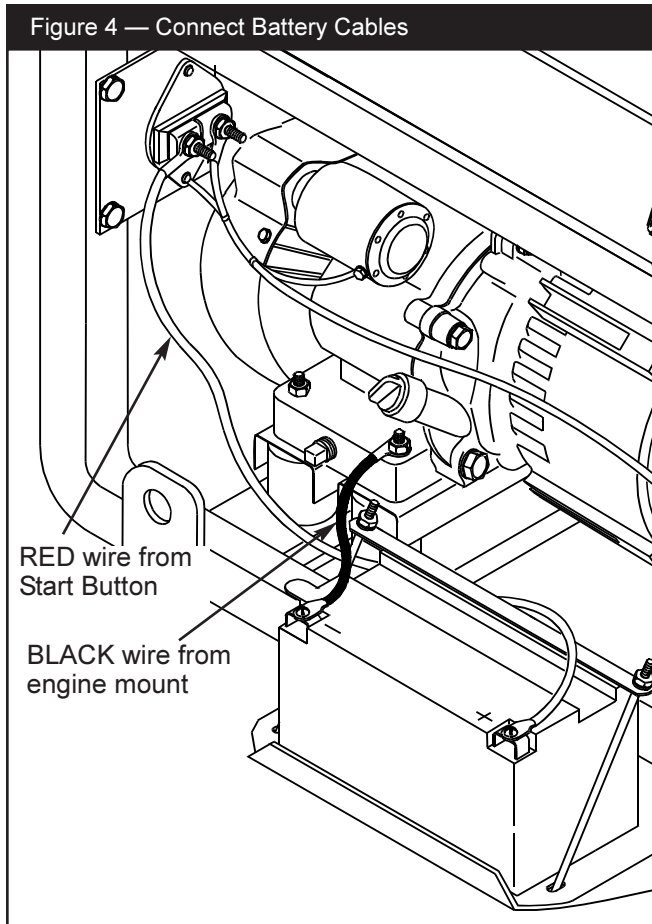

- Connect the black battery cable to the **negative (-)** terminal on battery (Figure 4).
- Connect the other end of the black cable to the engine mount, **not the frame**.

CAUTION: Be sure the black cable is connected to the engine mount, not the frame. You could damage the ground wire.

BEFORE STARTING THE ENGINE

Perform the following tasks before starting the unit:

Add Oil

WARNING! Any attempt to crank or start the engine before it has been properly filled with the recommended oil may result in an engine failure.

To fill your engine with oil:

- Place generator on a level surface.
- Follow the oil grade recommendations and oil fill instructions given in the engine owner's manual.

NOTE: The generator's revolving field rides on a prelubricated and sealed ball bearing that requires no additional lubrication for the life of the bearing.

Add Fuel

DANGER: NEVER fill fuel tank indoors. NEVER fill fuel tank when engine is running or hot. **Do Not** light a cigarette or smoke when filling the fuel tank.

CAUTION: **Do Not** overfill the fuel tank. Always allow room for fuel expansion.

Use only regular UNLEADED gasoline.

IMPORTANT: It is important to prevent gum deposits from forming in essential fuel system parts such as the carburetor, fuel filter, fuel hose or tank during storage. Also, experience indicates that alcohol-blended fuels (gasohol, ethanol or methanol) attract moisture, leading to separation and formation of acids during storage. Acidic gas can damage the fuel system of an engine.



To avoid engine problems, the fuel system should be emptied before storage of 30 days or longer. Drain the gas tank, start engine and let it run until the fuel lines and carburetor are empty. Use fresh fuel next season. See "Storage" on page 12.

Never use engine or carburetor cleaner products in the fuel tank or permanent damage may occur.

To add fuel:

- Clean area around fuel fill cap, remove cap.
- Slowly add "**UNLEADED**" regular gasoline to fuel tank. Leave about a 1/2" space in the fuel tank for fuel expansion (Figure 5). **Do Not** overfill fuel tank.

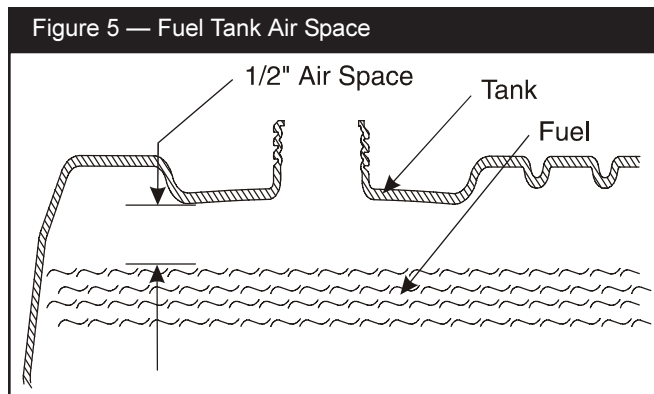

- Install fuel cap and wipe up any spilled gasoline.

OPERATING THE GENERATOR

CAUTION! Never start or stop unit with electrical loads connected AND with the connected devices turned ON.

Starting the Engine

- Disconnect **all** electrical loads from the generator.
- Open the fuel shut-off valve (Figure 6).

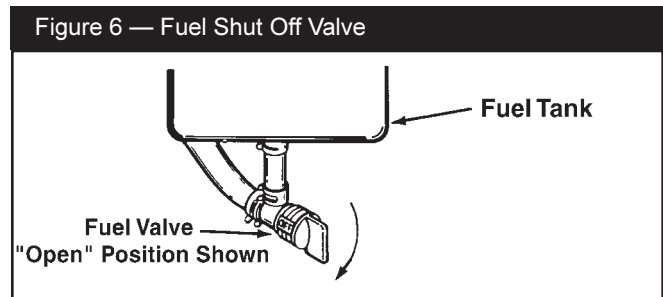

- Set the Run/Stop switch to "**Run**" position.
- Make sure the Idle Control switch is in "**Off**" position.
- Move engine choke to "**Full**" choke position (Figure 7).

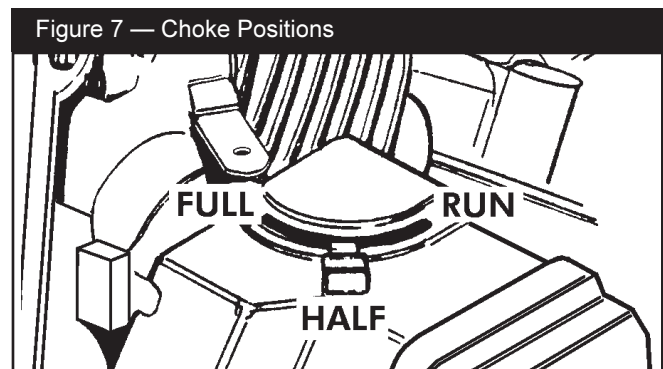

For electric start:

- Press electric start button until engine cranks and starts.

For manual start:

- Pull slowly on recoil handle until you feel some resistance. Then pull rapidly to start engine. Return recoil slowly, **Do Not** let it "snap back".



- When engine starts, move choke lever to “**Half**” choke position until the engine runs smoothly and then to “**Run**” position. If engine falters, move choke lever to “**Half**” choke position until the engine runs smoothly and then to “**Run**” position.

NOTE: If engine fails to start after 3 pulls, move the choke lever to “**Run**” position and pull starter rope again.

NOTE: If engine still fails to start after 3 pulls, check for proper oil level in crankcase. This unit is equipped with a Low Oil Shutdown System. See engine manual.

NOTE: If engine fires, but does not continue to run, move choke lever to “**Full**” choke position and repeat starting instructions.

Refer to the engine owner’s manual for complete starting instructions.

Applying Electrical Loads

- Let engine stabilize and warm up for about five minutes after starting.
- Plug in and turn on the desired 120 or 240 Volt AC, single phase, 60 Hz electrical loads.
DO NOT OVERLOAD THE GENERATOR. Review “Don’t Overload the Generator” on page 11.

Stopping the Engine

- Disconnect **all** electrical loads.
- Set the idle control to “**Off**” position.
- Run engine at no-load for about two minutes.
- Place the the Run/Stop switch to “**Stop**”.
- Close the fuel shut-off valve.

Operating Automatic Idle Control

This switch is designed to greatly improve fuel economy. When this switch is turned **ON**, the engine will only run at its normal high engine speed when an electrical load is connected. When the electrical load is removed, the engine will run at a reduced speed. With the switch **OFF**, the engine will run constantly at the normal high engine speed. **Always have the switch OFF when starting and stopping the engine.**

COLD WEATHER OPERATION

Under certain weather conditions (temperatures below 40°F [4°C] and a high dew point), your generator may experience icing of the carburetor and/or the crankcase breather system. In an emergency, use the original shipping box as a temporary shelter:

- Cut off all flaps and one of the long sides of the box to expose exhaust side of unit. Cut appropriate slots to access unit’s receptacles.
- Start unit, then place box over it. Ensure a minimum of two feet clearance between open side of box and nearest object.

IMPORTANT! Remove shelter when temperature is above 40°F [4°C].

For a more permanent shelter, build a structure that will enclose three sides and the top of the generator. Make sure entire muffler-side of generator is exposed, with two feet clearance between open side of box and nearest object. Face exposed end away from wind and elements (Figure 8).

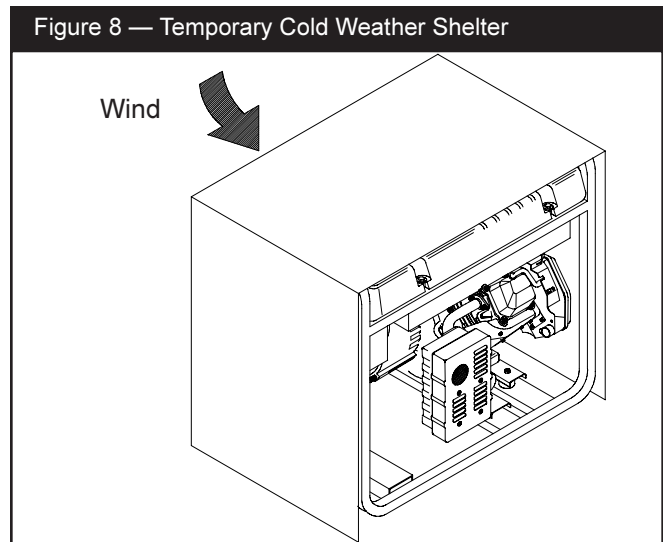



Charging a Battery

! DANGER: Storage batteries give off explosive hydrogen gas while recharging. An explosive mixture will remain around the battery for a long time after it has been charged. The slightest spark can ignite the hydrogen and cause an explosion. Such an explosion can shatter the battery and cause blindness or other injury.

! DANGER: Do Not permit smoking, open flame, sparks or any other source of heat around a battery. Wear protective goggles, rubber apron and rubber gloves when working around a battery. Battery electrolyte fluid is an extremely caustic sulfuric acid solution that can cause severe burns. If spill occurs, flush area with clear water immediately.

Your generator has the capability of recharging a discharged 12 Volt automotive or utility style storage battery. **Do Not** use the unit to charge any 6 Volt batteries. **Do Not** use the unit to crank an engine having a discharged battery.

To recharge 12 Volt batteries, proceed as follows:

- Check fluid level in all battery cells. If necessary, add **ONLY** distilled water to cover separators in battery cells. **Do Not use tap water.**
- If the battery is equipped with vent caps, make sure they are installed and are tight.
- If necessary, clean battery terminals.
- Connect battery charge cable connector plug to panel receptacle identified by the words "12-VOLT D.C."
- Connect battery charge cable clamp with **red** handle to the **positive (+)** battery terminal (Figure 9).

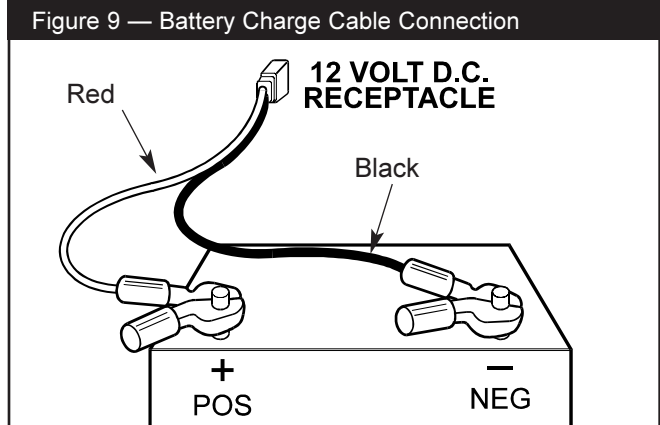

- Connect battery charge cable clamp with **black** handle to the **negative (-)** battery terminal (Figure 9).
- Start engine. Let the engine run while battery recharges.
- When battery has charged, shut down engine.

NOTE: Use an automotive hydrometer to test battery state of charge and condition. Follow the hydrometer manufacturer's instructions carefully. Generally, a battery is considered to be at 100% state of charge when specific gravity of its fluid (as measured by hydrometer) is 1.260 or higher.



CORD SETS/RECEPTACLES

This generator is equipped with the following receptacles:

120 Volt AC, 20 Amp Receptacles

Each socket (Figure 10) is protected against overload by a 20 Amp push-to-reset circuit breaker. Use each receptacle to operate 120 Volt AC, single phase, 60 Hz electrical loads requiring up to 2400 watts (2.4 kW) at 20 Amps of current.

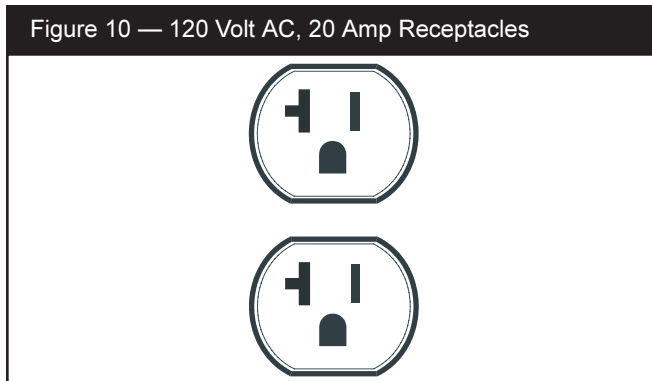

Use cord sets that are rated for 125 Volt AC loads at 20 Amps (or greater).

120 Volt AC, 30 Amp Locking Receptacle

Use a NEMA L5-30 plug with this receptacle. Connect a 3-wire cord set rated for 125 Volts AC at 30 Amps to the plug (Figure 11).

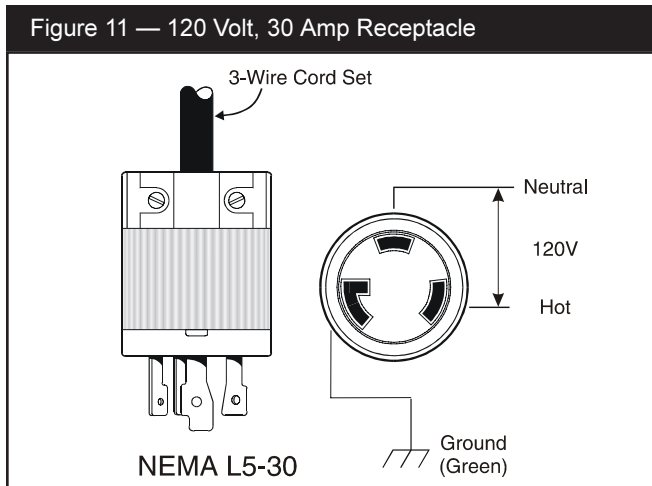

Use this receptacle to operate 120 Volt AC, 60 Hz, single phase loads requiring up to 3600 watts (3.6 kW) of power at 30 Amps. The outlet is protected by a 30 Amp push-to-reset circuit breaker.

120/240 Volt AC, 30 Amp Locking Receptacle

Use a NEMA L14-30 plug with this receptacle. Connect a 4-wire cord set rated for 250 Volt AC loads at 30 Amps (or greater) (Figure 12). You can use the same 4-wire cord if you plan to run a 120 Volt load.

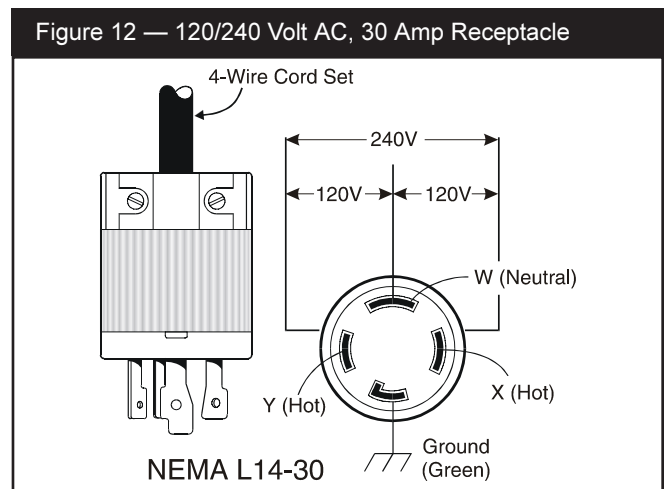

This receptacle powers 120/240 Volt AC, 60 Hz, single phase loads requiring up to 3,600 watts of power (3.6 kW) at 30 Amps for 120 Volts OR 5,500 watts of power (5.5 kW) at 22.9 Amps for 240 Volts. The outlet is protected by a 30 Amp push-to-reset circuit breaker.

CAUTION! Although this outlet states it has a 240 Volt 30 Amp rating (up to 7,200 watts), the generator is only rated for 5,500 watts. Powering loads that exceed the wattage/ amperage capacity of the generator can damage it or cause serious injuries. 240 Volt loads powered through this outlet should not exceed 22.9 Amps of current draw.



DON'T OVERLOAD THE GENERATOR

Overloading a generator in excess of its rated wattage capacity can result in damage to the generator and/or connected electrical devices. Observe the following, to prevent overloading the unit:

- Add up the total wattage of all electrical devices to be connected at one time. This total should NOT be greater than the generator's wattage capacity.
- If the appliance, tool or motor does not give wattage, multiply 120 Volts times ampere rating to determine watts (volts x amps = watts).

- The rated wattage of lights can be taken from wattage listed on the light bulbs. The rated wattage of tools, appliances and motors can usually be found on a data plate or decal affixed to the device. Use Figure 13 below as a general reference.
- Some electric motors, such as induction types, require about three times more watts of power for starting than for running. This surge of power lasts for only a few seconds when starting such motors. Be sure you allow for this high starting wattage when selecting electrical devices to connect to your generator. First figure the watts needed to start the largest motor. Add to that figure the running watts of all other connected loads.

Figure 13 — Wattage Reference Guide

Device	Load (watts)	Device	Load (watts)
*Air Conditioner (12,000 Btu)	1700	Hedge Trimmer	450
*Air Conditioner (24,000 Btu)	3800	Impact Wrench	500
*Air Conditioner (40,000 Btu)	6000	Iron	1200
Battery Charger (20 Amp)	500	*Jet Pump	800
Belt Sander (3")	1000	Lawn Mower	1200
Chain Saw	1200	Light Bulb	100
Circular Saw (6-1/2")	800 to 1000	Microwave Oven	700 to 1000
*Clothes Dryer (Electric)	5750	*Milk Cooler	1100
*Clothes Dryer (Gas)	700	Oil Burner on Furnace	300
*Clothes Washer	1150	Oil Fired Space Heater (140,000 Btu)	400
Coffee Maker	1750	Oil Fired Space Heater (85,000 Btu)	225
*Compressor (1 HP)	2000	Oil Fired Space Heater (30,000 Btu)	150
*Compressor (3/4 HP)	1800	*Paint Sprayer, Airless (1/3 HP)	600
*Compressor (1/2 HP)	1400	Paint Sprayer, Airless (handheld)	150
Curling Iron	700	Radio	50 to 200
*Freezer	700	*Refrigerator	700
*Dehumidifier	650	Slow Cooker	200
Disc Sander (9")	1200	*Submersible Pump (1-1/2 HP)	2800
Edge Trimmer	500	*Submersible Pump (1 HP)	2000
Electric Blanket	400	*Submersible Pump (1/2 HP)	1500
Electric Nail Gun	1200	*Sump Pump	800 to 1050
Electric Range (per element)	1500	*Table Saw (10")	1750 to 2000
Electric Skillet	1250	Television	200 to 500
*Furnace Fan (3/5 HP)	875	Toaster	1000 to 1650
*Garage Door Opener	500 to 750	Weed Trimmer	500
Hair Dryer	1200		
Hand Drill	250 to 1100		

* Allow 3 times the listed watts for starting these devices.

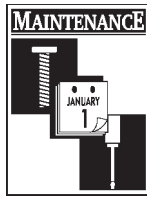

GENERAL MAINTENANCE RECOMMENDATIONS

The owner/operator is responsible for making sure that all periodic maintenance tasks are completed on a timely basis; that all discrepancies are corrected; and that the unit is kept clean and properly stored. **Never operate a damaged or defective generator.**

Engine Maintenance

See engine manual for instructions.

Generator Maintenance

Generator maintenance consists of keeping the unit clean and dry. Operate and store the unit in a clean dry environment where it will not be exposed to excessive dust, dirt, moisture or any corrosive vapors. Cooling air slots in the generator must not become clogged with snow, leaves or any other foreign material.

Check the cleanliness of the generator frequently and clean when dust, dirt, oil, moisture or other foreign substances are visible on its exterior surface.

NOTE: Do Not use a garden hose to clean generator. Water can enter engine fuel system and cause problems. In addition, if water enters generator through cooling air slots, some of the water will be retained in voids and cracks of the rotor and stator winding insulation. Water and dirt buildup on the generator internal windings will eventually decrease the insulation resistance of these windings.

Clean the Generator

- Use a damp cloth or soft bristle brush to wipe exterior surfaces clean.
- A vacuum cleaner may be used to pick up loose dirt and debris.
- Low pressure air (not to exceed 25 psi) may be used to blow away dirt. Inspect cooling air slots and opening on generator. These openings must be kept clean and unobstructed.

SERVICE/ADJUSTMENTS

Refer to engine owner's manual for information.

STORAGE

The generator should be started at least once every seven days and allowed to run at least 30 minutes.

If this cannot be done and you must store the unit for more than 30 days, use the following guidelines to prepare it for storage.

Generator Storage

- Clean the generator as outlined in "To Clean the Generator."
- Check that cooling air slots and openings on generator are open and unobstructed.
- Disconnect the negative battery cable from the battery.



DANGER: Storage covers can be flammable. **Do Not** place a storage cover over a hot generator. Let the unit cool for a sufficient time before placing the cover on the unit.

Engine Storage

See engine owner's manual for instructions on how to properly store the engine.

Other Storage Tips

- **Do Not** store gasoline from one season to another.
- Replace your gasoline can if it starts to rust. Rust and/or dirt in a gasoline can cause problems when you use contaminated fuel with this unit.
- Store in clean and dry area.

SPECIFICATIONS

Rated Maximum Continuous AC Power Output	5500 watts (5.5 kW)
Rated AC Voltage	120/240 Volts
Rated Maximum AC Current:	
at 240 Volts	22.9 Amperes
at 120 Volts	45.8 Amperes
Phase	1
Rated AC Frequency	60 Hertz
Number of Rotor Poles	2
Driven Speed of Rotor	3600 RPM



TROUBLESHOOTING

Problem	Cause	Correction
Engine is running, but no AC output is available.	<ol style="list-style-type: none"> 1. One of the circuit breakers is open. 2. Fault in generator. 3. Poor connection or defective cord set. 4. Connected device is bad. 	<ol style="list-style-type: none"> 1. Reset circuit breaker. 2. Contact Generac service facility. 3. Check and repair. 4. Connect another device that is in good condition.
Engine runs good at no-load but "bogs" down" when loads are connected.	<ol style="list-style-type: none"> 1. Short circuit in a connected load. 2. Engine speed is too slow. 3. Generator is overloaded. 4. Shorted generator circuit. 	<ol style="list-style-type: none"> 1. Disconnect shorted electrical load. 2. Contact Generac service facility. 3. See "Don't Overload the Generator" on page 11. 4. Contact Generac service facility.
Engine will not start; or starts and runs rough.	<ol style="list-style-type: none"> 1. Run/Stop Switch set to "Stop". 2. Dirty air cleaner. 3. Out of gasoline. 4. Stale gasoline. 5. Spark plug wire not connected to spark plug. 6. Bad spark plug. 7. Water in gasoline. 8. Overchoking. 9. Excessively rich fuel mixture. 10. Intake valve stuck open or closed. 11. Engine has lost compression. 12. Failed battery. 	<ol style="list-style-type: none"> 1. Set switch to "Run". 2. Clean or replace air cleaner. 3. Fill fuel tank. 4. Drain gas tank; fill with fresh fuel. 5. Connect wire to spark plug. 6. Replace spark plug. 7. Drain gas tank; fill with fresh fuel. 8. Open choke fully and crank engine. 9. Contact Generac service facility. 10. Contact Generac service facility. 11. Contact Generac service facility. 12. Replace battery.
Engine shuts down during operation.	<ol style="list-style-type: none"> 1. Out of gasoline. 2. Low oil level. 	<ol style="list-style-type: none"> 1. Fill fuel tank. 2. Fill crankcase to proper level.
Engine lacks power.	<ol style="list-style-type: none"> 1. Load is too high. 2. Dirty air filter. 	<ol style="list-style-type: none"> 1. See "Don't Overload the Generator" on page 11. 2. Replace air filter.
Engine "hunts" or falters.	<ol style="list-style-type: none"> 1. Choke is opened too soon. 2. Carburetor is running too rich or too lean. 	<ol style="list-style-type: none"> 1. Move choke to halfway position until engine runs smoothly. 2. Contact Generac service facility.



SCHEMATIC DIAGRAM

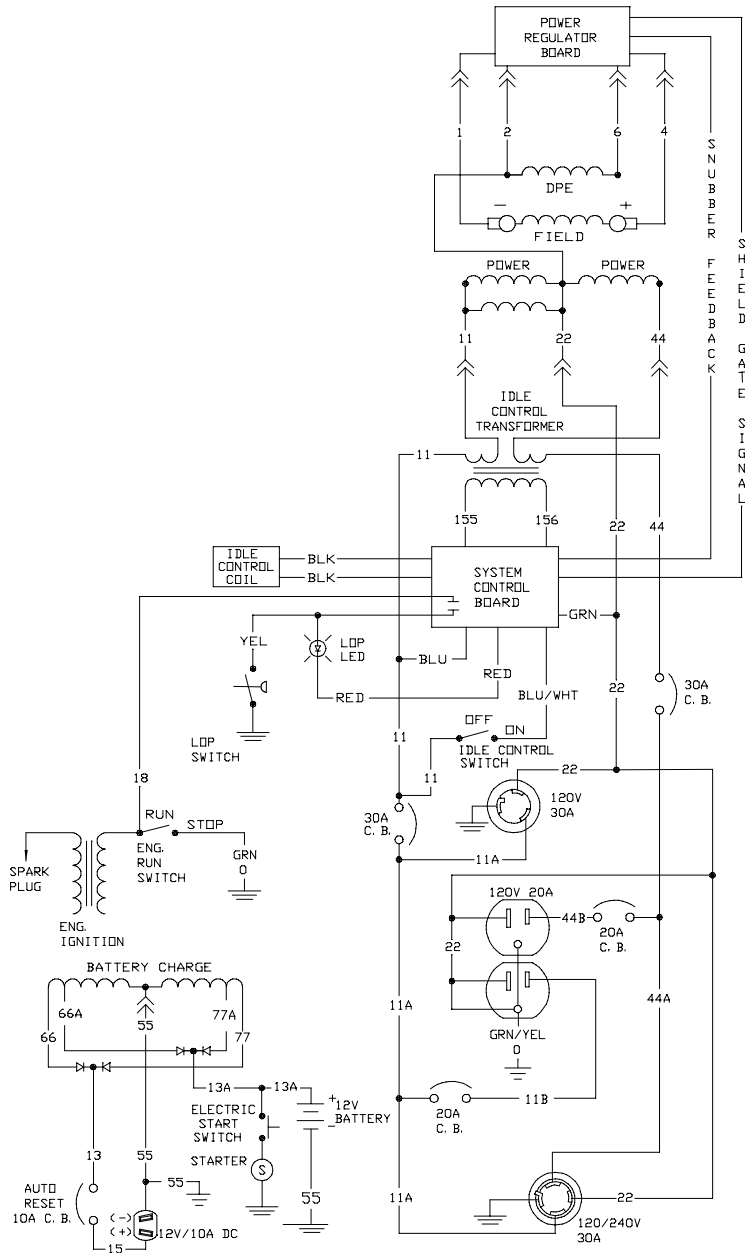

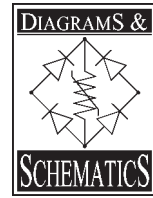

WIRING DIAGRAM

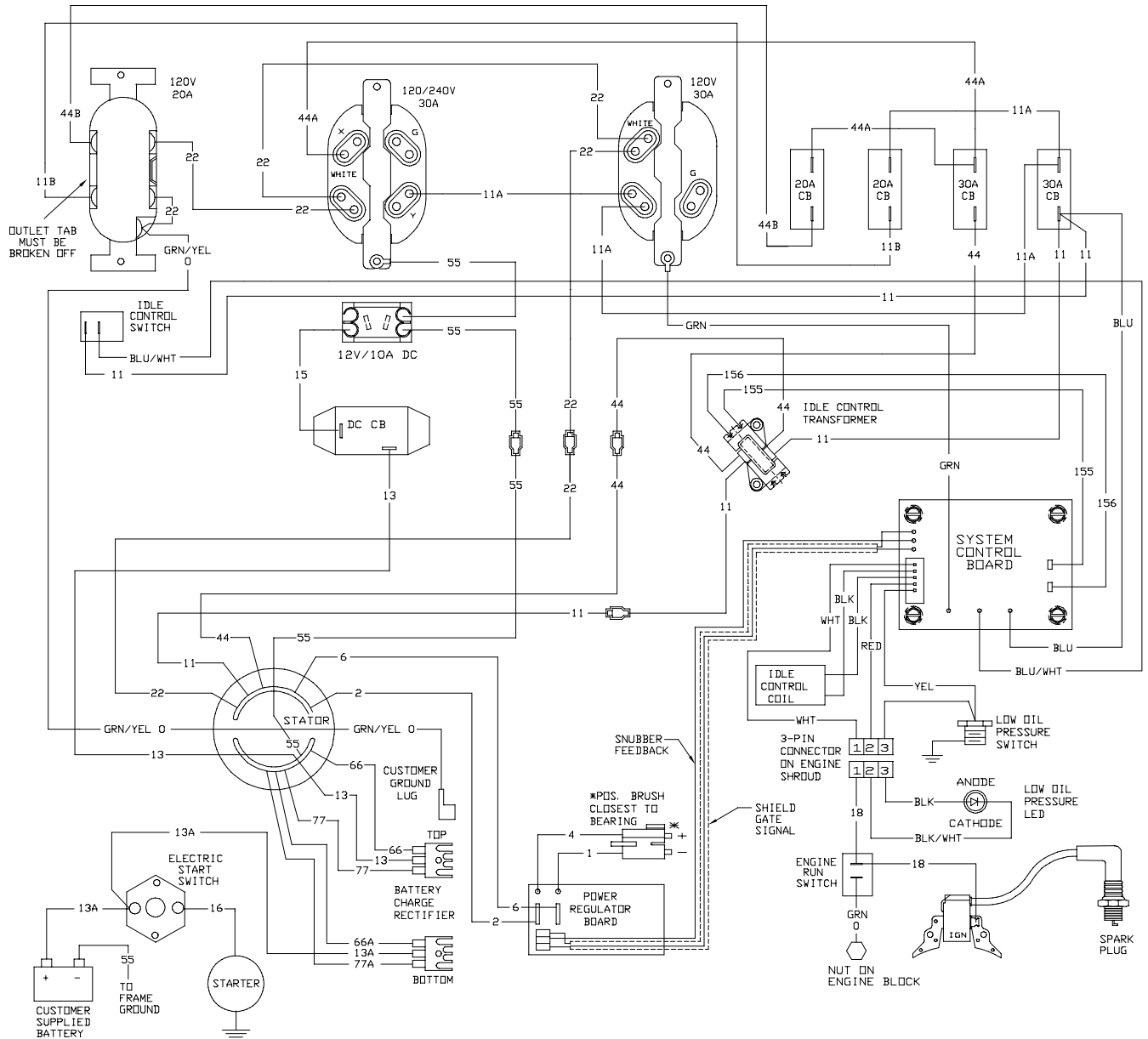

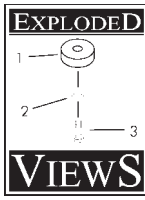

EXPLODED VIEW

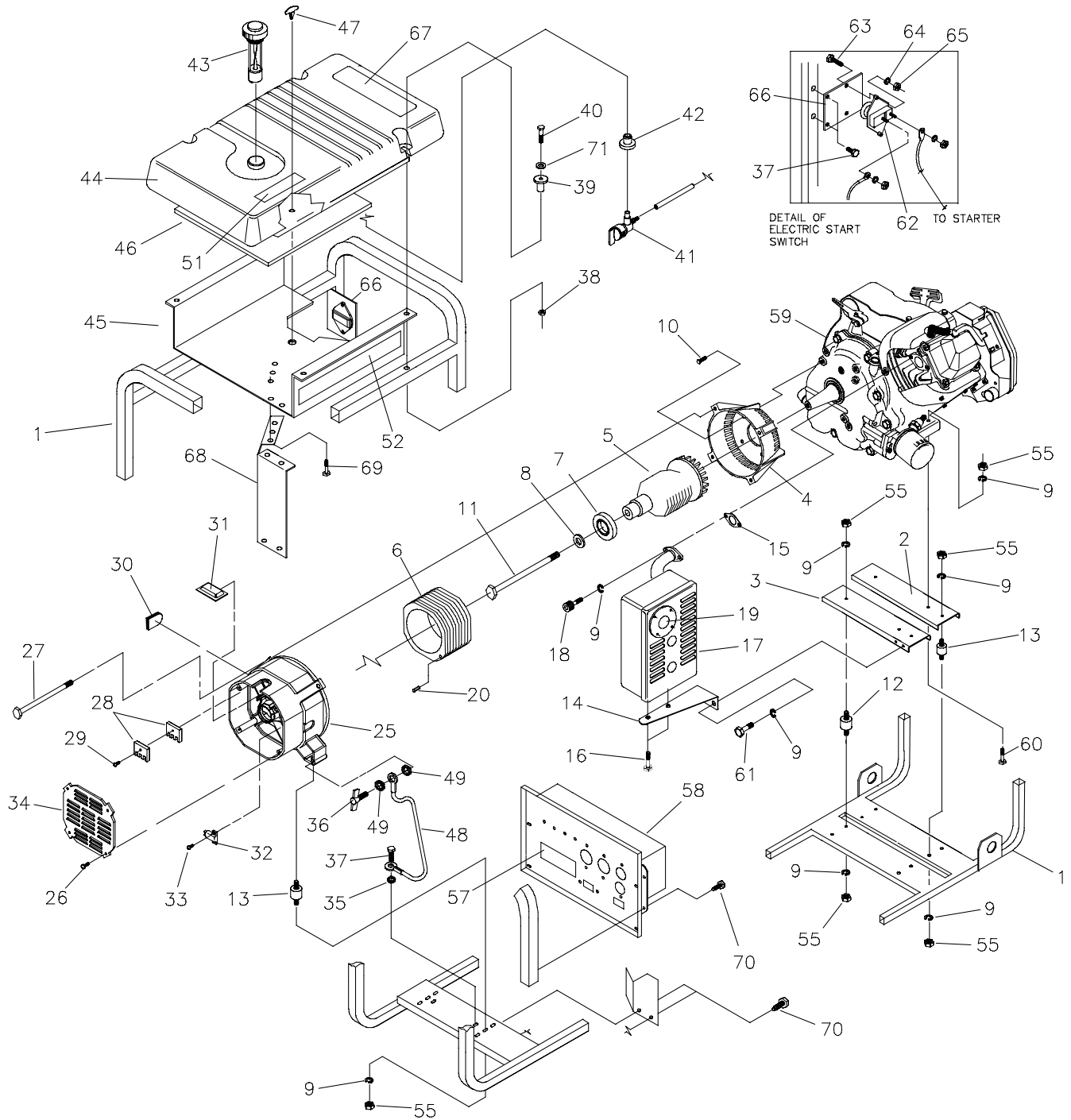

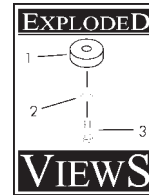

PARTS LIST

Item	Part #	Qty.	Description	Item	Part #	Qty.	Description
1	A92432	1	CRADLE	46	92665	1	INSULATION, #2-1/4" Thick
2	A92531	1	SUPPORT, Engine	47	85000	1	CLIP, Insulation
3	A92731	1	SUPPORT, Engine & Muffler	48	14353621	1	WIRE, Ground
4	92247	1	HOUSING, Engine Adapter	49	26850	2	LW, EXT, Shakeproof M6
5	92678G	1	ASSEMBLY, Rotor	51	92982	1	DECAL, Danger
6	94980A	1	ASSEMBLY, Stator	52	96057	2	DECAL, Heat Shield
7	65791	1	BEARING	55	25244	12	NUT, 5/16-18 Hex
8	67451	1	WASHER, Special Flat - M8	57	96058	1	DECAL, Control Panel
9	22129	16	WASHER, Lock - M8	58	92630	1	ASSEMBLY, Control Box
10	86307	4	HHMS, 5/16-24 x 3/4	59	NSP	1	ENGINE
11	28092	1	HHCS, 5/16-24 x 9-1/4	60	22531	2	HHCS, 5/16-18 x 1-3/4"
12	92609	2	MOUNT, Vibration	61	22142	2	SCREW, 5/16-18 x 3/4"
13	82857	4	MOUNT, Vibration	62	77282	1	SWITCH, Starter
14	92532	1	BRACKET, Muffler	63	22287	2	SCREW, 1/4 - 20 x 3/4
15	90239	1	GASKET, Muffler	64	22097	2	LOCKWASHER, M6
16	66476	2	CAPSCREW, M6 - 1.0 x 12mm	65	22127	2	NUT, 1/4 - 20 Hex
17	A7433	1	MUFFLER	66	78289	1	BRACKET, Starter Switch
18	40976	2	SCREW, M8 - 1.25 x 20	67	93826	1	DECAL, Start Instructions
19	83083	1	SCREEN, Spark Arrester	68	B96068	1	SHIELD, Heat
20	81917	1	PIN, Roll 4mm x 10	69	56893	5	CRIMPTITE, 10-24 x 1/2
25	66825C	1	CARRIER, Rear Bearing	70	B2153	8	SCREW, #12 Self Drill
26	74908	4	TAPTITE, M5-0.8 x 10	71	22473	4	WASHER, Flat M6
27	86308A	4	BOLT, Stator M6-1 x 145mm	Parts Not Illustrated:			
28	65795	2	RECTIFIER, Battery Charge	37806	1	125V 30A Locking plug	
29	66849C	1	TAPTITE, M5-0.8 x 30	43438	1	240V 30A Locking plug	
30	67022	1	GROMMET, Rubber	72347	1	Spark plug	
31	84132	1	ASSEMBLY, Power Regulator	73111	1	Air cleaner element	
32	66386	1	ASSEMBLY, Brush Holder	84882	1	Spark plug wrench	
33	66849	2	TAPTITE, M5-0.8 x 16	20820	1	Owners manual	
34	B67025	1	COVER, Bearing Carrier	65787	1	Battery charge cable	
35	22769	1	WASHER, Shakeproof Int. #10	Battery Tray Components:			
36	86494	1	SCREW, M6-1.0 x 16 Wing	22129	2	Lockwasher, M8	
37	86292	1	HHCS, - #10 Self Driller	45771	2	Hex nut M8	
38	77395	4	NUT, Flange Lock - M6	96925	1	Battery tiedown	
39	83465	4	GROMMET, Tank	96924	2	J-bolt	
40	57058	4	HHCS, M6-1.0 x 55	15453621	1	Battery cable, positive	
41	80270	1	VALVE, Tank	15553621	1	Battery cable, negative	
42	78299	1	BUSHING, Tank	96923	1	Battery tray	
43	B4363	1	CAP, with Gauge, Fuel	22145	2	Flat washer	
44	B1695	1	TANK, Fuel 7 Gal.	58443	4	Screws, battery tray	
45	B92039	1	SHIELD, Heat				

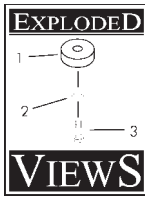

CONTROL PANEL EXPLODED VIEW & PARTS LIST

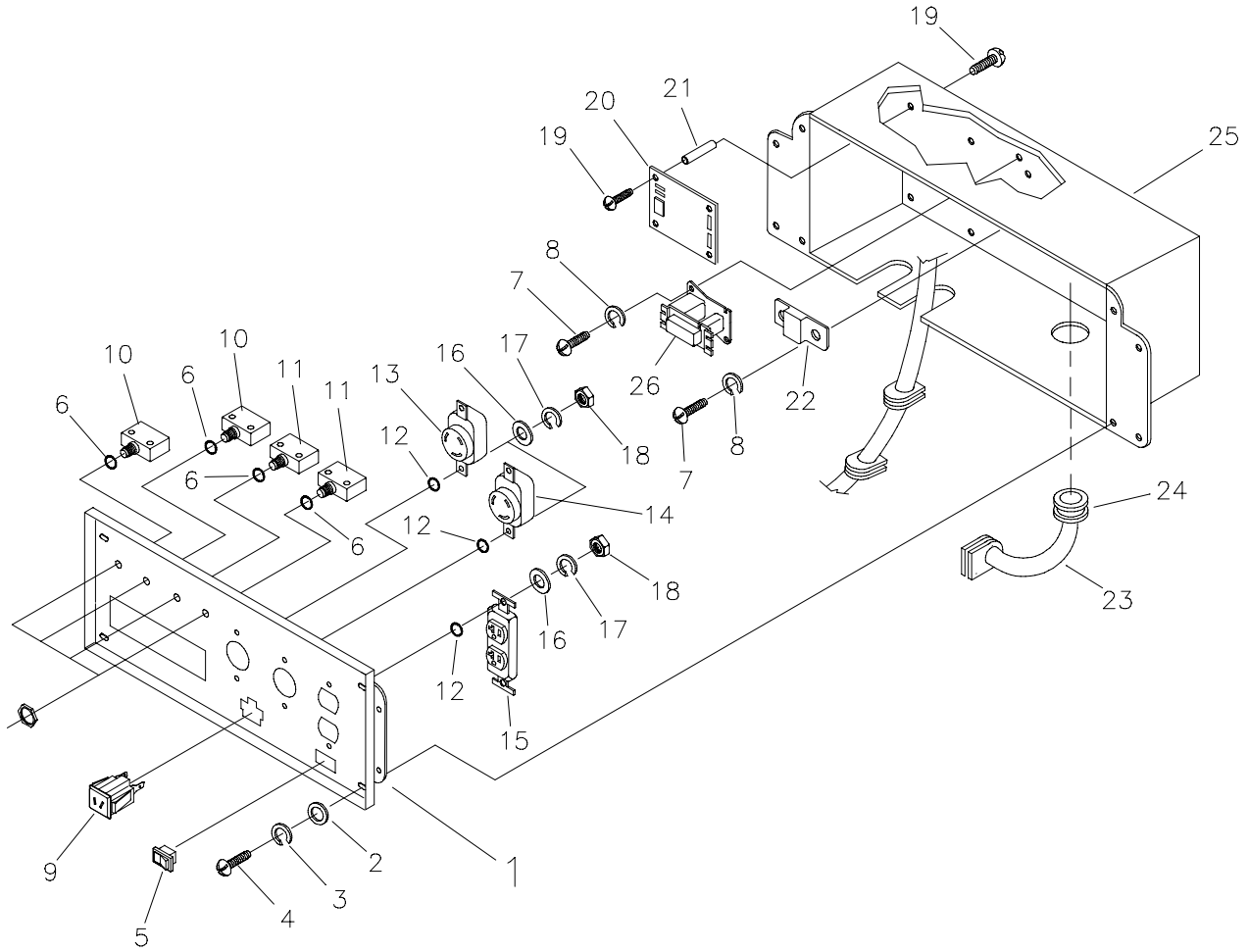

Item	Part #	Qty.	Description	Item	Part #	Qty.	Description
1	A92070	1	PANEL, Control	14	43437	1	OUTLET, 120V/240V, 30A Locking Type
2	23897	4	FLAT WASHER, #10 M5	15	68759	1	OUTLET, 120V, 20A Duplex
3	49226	4	LOCK WASHER, M5	16	43180	6	FLAT WASHER, M4
4	91526	4	SCREW, M5-0.8 x 12mm	17	22264	6	LOCK WASHER, #8 M4
5	82538	1	SWITCH, Idle Control	18	51715	6	NUT, M4-0.7 Hex
6	82881	4	LOCK WASHER, 7/16"	19	64526	8	SCREW, #6-32 x 3/8"
7	43181	4	SCREW, M3 - 0.5 x 10mm	20	83970	1	BOARD, System Control
8	43182	4	LOCK WASHER, M3	21	64525	4	STAND-OFF, 3/4" Hex
9	90418	1	OUTLET, 12V	22	87962	1	CIRCUIT BREAKER. 12V, 10A (auto)
10	75207A	2	CIRCUIT BREAKER, 30A	23	84335	1	ASSEMBLY, Wire Harness
11	75207	2	CIRCUIT BREAKER, 20A	24	84134	1	GROMMET, Rubber Conn
12	23365	6	WASHER, #8 Shakeproof	25	B92069	1	BOX, Control Panel
13	68868	1	OUTLET, 120 Volt, 30 Amp Locking Type	26	84028	1	TRANSFORMER, Idle Control

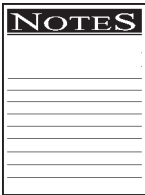

NOTES

Lined area for writing notes.

LIMITED WARRANTY

FOR "GN" ENGINE DRIVEN PORTABLE GENERATORS

GENERAC PORTABLE PRODUCTS (hereafter referred to as the COMPANY) warrants to the original purchaser that the alternator and control panel for its portable generator will be free from defects in materials or workmanship for the items and period set forth below from the date of original purchase. This warranty is not transferable and applies only to portable generators driven by a GN-Series engine.

	Consumer*	Commercial*
Alternator	2 years (2nd year parts only)	1 year
Engine	Warranted solely by the engine manufacturer	

With the exception of European Community Countries, all units bound for export shall be warranted for One (1) Year in Consumer applications, and 90 days in Commercial applications as defined below.

***NOTE: For the purpose of this warranty "consumer use" means personal residential household use by original purchaser. This warranty does not apply to units used for Prime Power in place of utility. "Commercial Use" means all other uses, including rental, construction, commercial and income producing purposes. Once a generator has experienced commercial use, it shall thereafter be considered a commercial use generator for the purposes of this warranty.**

During said warranty period, the COMPANY will, at its option, repair or replace any part which, upon examination by the COMPANY, is found to be defective under normal use and service**. Starting batteries are not warranted by the COMPANY. All transportation costs under warranty, including return to the factory if necessary, are to be borne by the purchaser and prepaid by the purchaser. This warranty does not cover normal maintenance and service and does not apply to a generator set, alternator, or parts which have been subjected to improper or unauthorized installation or alteration, misuse, negligence, accident, overloading, overspeeding, improper maintenance, repair or storage so as, in the COMPANY's judgement, to adversely affect its performance and reliability.

****NORMAL WEAR: As with all mechanical devices, the generator need periodic parts service and replacement to perform well. This warranty will not cover repair when normal use has exhausted the life of a part or generator.**

THERE IS NO OTHER EXPRESS WARRANTY. THE COMPANY HEREBY DISCLAIMS ANY AND ALL IMPLIED WARRANTIES, INCLUDING BUT NOT LIMITED TO THOSE OF MERCHANTABILITY AND FITNESS FOR A PARTICULAR PURPOSE TO THE EXTENT PERMITTED BY LAW. THE DURATION OF ANY IMPLIED WARRANTIES WHICH CANNOT BE DISCLAIMED IS LIMITED TO THE TIME PERIOD AS SPECIFIED IN THE EXPRESS WARRANTY. LIABILITY FOR CONSEQUENTIAL, INCIDENTAL OR SPECIAL DAMAGES UNDER ANY AND ALL WARRANTIES IS EXCLUDED. THE COMPANY ALSO DISCLAIMS ANY RESPONSIBILITY FOR INCIDENTAL OR CONSEQUENTIAL DAMAGES, SUCH AS THE LOSS OF TIME OR THE USE OF THE POWER EQUIPMENT, OR ANY COMMERCIAL LOSS DUE TO THE FAILURE OF THE EQUIPMENT: AND ANY IMPLIED WARRANTIES ARE LIMITED TO THE DURATION OF THIS WRITTEN WARRANTY.

Some states do not allow limitations on how long an implied warranty lasts, or the exclusion or limitation of incidental or consequential damages, so the above limitations or exclusions may not apply to you. This warranty gives you specific legal rights and you may also have other rights, which vary from state to state.

For service, see your nearest COMPANY authorized warranty service facility or call 1-877-544-0982. Warranty service can be performed only by a COMPANY authorized service facility. This warranty will not apply to service at any other facility. At the time of requesting warranty service, evidence of original purchase date must be presented.

GENERAC PORTABLE PRODUCTS
Jefferson, Wisconsin 53549

Free Manuals Download Website

<http://myh66.com>

<http://usermanuals.us>

<http://www.somanuals.com>

<http://www.4manuals.cc>

<http://www.manual-lib.com>

<http://www.404manual.com>

<http://www.luxmanual.com>

<http://aubethermostatmanual.com>

Golf course search by state

<http://golfingnear.com>

Email search by domain

<http://emailbydomain.com>

Auto manuals search

<http://auto.somanuals.com>

TV manuals search

<http://tv.somanuals.com>