

0F9765MNL

GENERAC[®]
POWER SYSTEMS, INC.

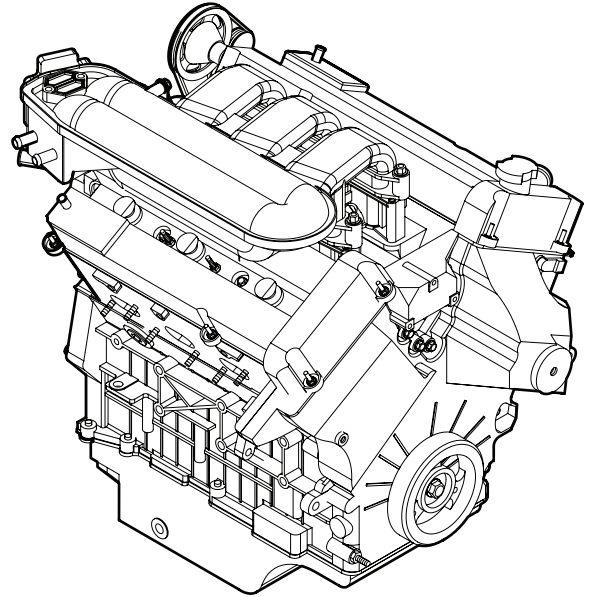

3.0

G A S

LITER

***Ford
Duratec***

***ENGINE
PARTS
MANUAL***

P.O. BOX 310 EAGLE WI 53119

PRINTED IN U.S.A.

Revision 0: 09/12/06

3.0L GAS ENGINE TABLE OF CONTENTS

QUICK REFERENCE GUIDE	1
SERVICE RECOMMENDATIONS	2
CYLINDER BLOCK & RELATED PARTS	6
CYLINDER BLOCK & RELATED PARTS	7
CYLINDER HEAD & RELATED PARTS	8
CYLINDER HEAD & RELATED PARTS	9
PISTON & CONNECTING ROD	10
TIMING COMPONENTS	11
CRANKSHAFT & RELATED PARTS	12
CRANKSHAFT & RELATED PARTS	13
ENGINE COMMON PARTS	14

LEGEND

“AR” AS REQUIRED
“STD” STANDARD SIZE
“O.S.” OVERSIZE
“U.S.” UNDERSIZE
“NA” NOT AVAILABLE

NOTICE!

THE INFORMATION IN THIS MANUAL IS KNOWN TO BE ACCURATE AS OF THE DATE OF RELEASE SHOWN ON THE COVER. HOWEVER, ENGINEERING CHANGES CAN OCCUR WITHOUT NOTICE. TO OBTAIN THE PROPER PARTS, PLEASE BE SURE TO USE THE MODEL NUMBER OF THE UNIT BEING SERVICED WHEN ORDERING FROM THIS MANUAL.

3.0L GAS ENGINE QUICK REFERENCE GUIDE

QUICK REFERENCE ENGINE PARTS

ENGINE SIZE: 3.0 Liter	FUEL: Gas	MAKE: Ford	ENGINE P/N: 0F9765	MODEL: —	
OIL CAPACITY: <i>1.0 gallons (w/filter)</i>		COOLANT CAPACITY: <i>4.0 gallons</i>		User Notes	
SCHEDULED MAINTENANCE KITS					
<i>Description</i>			<i>Part Number</i>		
Oil/Air			NA		
—			—		
COMMON REFERENCE PARTS					
<i>Description</i>	<i>Part Number</i>	<i>Special Notes</i>			
Oil Filter (Main)	0D5419				
Fuel Filter	NA				
Air Cleaner Element		Check BOM			
V-Belt	0D3488N	Serpentine			
Thermostat	075885				
Thermostat Gasket	048665				
Water Pump	0F9225				
Starter Motor	0E9747				
Spark Plug	0F97650226				
ADDITIONAL REFERENCE PARTS					
Alternator	0E9868A				
Ignition Coil	0F9228				

◆ Engine Oil Recommendations

The unit has been filled with “break in” engine oil at the factory. Use a high-quality detergent oil classified “For Service CC, SD, SE or SF.” Detergent oils keep the engine cleaner and reduce carbon deposits. Use oil having the following SAE viscosity rating, based on the ambient temperature range anticipated before the next oil change:

Temperature	Oil Grade (Recommended)
Above 75° F (24° C)	SAE 30W
40° to 75° F (4.4° to 24° C)	SAE 20W or 15W-40
10° to 40° F (-12° to 4.4° C)	SAE 10W or 15W-40
Below 10° F (-12° C)	SAE 5W-30 (Synthetic) or 5W-20

◆ Coolant

Use a mixture of half low silicate, ethylene glycol base antifreeze and half soft water. Use only soft water and only low silicate antifreeze. If desired, you may add a high quality rust inhibitor to the recommended coolant mixture. When adding coolant, always add the recommended 50-50 mixture.



Do not remove the radiator pressure cap while the engine is hot or serious burns from boiling liquid or steam could result.



Ethylene glycol base antifreeze is poisonous. Do not use your mouth to siphon coolant from the radiator, recovery bottle or any container. Wash your hands thoroughly after handling. Never store used antifreeze in an open container because animals are attracted to the smell and taste of antifreeze even though it is poisonous to them.



Do not use any chromate base rust inhibitor with ethylene glycol base antifreeze, or chromium hydroxide (“green slime”) will form and cause overheating. Engines that have been operated with a chromate base rust inhibitor must be chemically cleaned before adding ethylene glycol base antifreeze. Using any high silicate anti-freeze boosters or additives also will cause overheating. We also recommend that you DO NOT use any soluble oil inhibitor for this equipment.

3.0L GAS ENGINE SERVICE RECOMMENDATIONS

8 kW - 35 kW Small Standby Generator Sets

Following is a recommended maintenance schedule for Generac small standby and residential generator sets from 8 kW to 35 kW in size, and applies to both diesel engine and gas engine driven units. The established intervals in the schedule are the *maximum* recommended when the unit is used in an average service application. They will need to be decreased (performed more frequently) if the unit is used in a severe application. Use the unit hour meter or calendar time, whichever occurs first, from the previous maintenance interval to determine the next required maintenance interval.

Service Maintenance Interval Information:

The various service maintenance intervals are designated by interval numbers as follows:

- 1 An early inspection of the generator set to insure it is ready to operate when required and to identify any potential problem areas.

Performed monthly or following each 10 hours of operation of the unit and requires approximately .5 man-hours per unit to complete.

This inspection may be performed by the end user providing the following safety steps are taken to prevent the engine from starting automatically without warning:

To prevent injury, perform the following steps in the order indicated before starting any maintenance:

- **Disable the generator set from starting and/or connecting to the load by setting the control panel Auto-Off-Manual switch to the "OFF" position.**
- **Remove the control panel fuse.**
- **Turn off the battery charger.**
- **Remove the negative battery cable.**



The battery charger must be turned off BEFORE removing the battery cable to prevent an over current condition from burning out sensitive control panel components and circuits.

Following all maintenance, reverse these steps to insure the unit is returned to standby setup for normal operation when required.

- 2 A break-in service inspection of the generator set to insure it is ready to operate and carry the load when required, and to identify any potential problem areas.

*Performed **ONLY ONCE** following the first three months or the first 30 hours of operation after purchase of the unit and requires approximately 2.5 man-hours per unit to complete.*

This inspection contains some maintenance tasks which require special tools, equipment, and/or knowledge to accomplish and should be performed only by an authorized Generac Service Dealer.

- 3 An operational inspection of the generator set to insure it is ready to operate and carry the load when required, and to identify any potential problem areas.

Performed semi-annually or following each 50 hours of operation of the unit and requires approximately 1.5 man-hours per unit to complete.

This inspection contains some maintenance tasks which require special tools, equipment, and/or knowledge to accomplish and should be performed only by an authorized Generac Service Dealer.

- 4 A mid-level inspection of the generator set to insure it is ready to operate and carry the load when required, and to identify any potential problem areas.

Performed annually or following each 100 hours of operation of the unit and requires approximately 4.0 man-hours per unit to complete.

This inspection contains some maintenance tasks which require special tools, equipment, and/or knowledge to accomplish and should be performed only by an authorized Generac Service Dealer.

3.0L GAS ENGINE SERVICE RECOMMENDATIONS

GENERAC POWER SYSTEMS, INC.

RECOMMENDED SCHEDULED MAINTENANCE PROGRAM SERVICE WORK TO BE PERFORMED BY FACTORY-TRAINED PERSONNEL ONLY.

DEALER INFORMATION

NAME: _____
ACCOUNT #: _____
ADDRESS: _____

PHONE: _____
TECHNICIAN: _____
SIGNATURE: _____

OWNER INFORMATION

NAME: _____
ADDRESS: _____

SITE: _____
PHONE: _____

SIGNATURE: _____

PURCHASE DATE: _____

START-UP DATE: _____

APPLICATION: ___ Standby Power ___ Prime Power ___ Rental/Trailerized

GENERATOR & TRANSFER SWITCH INFORMATION

GENERATOR

MODEL NUMBER: _____
SERIAL NUMBER: _____

TRANSFER SWITCH

MODEL NUMBER: _____
SERIAL NUMBER: _____

HOUR METER READING *at Completion of the Inspection*: _____

WARNING!

To prevent injury, perform the following steps in the order indicated before starting any maintenance:

- Disable the generator set from starting and/or connecting to the load by setting the control panel Auto-Off-Manual switch to the "OFF" position.
- Remove the control panel fuse.
- Turn off the battery charger.
- Remove the negative battery cable.

NOTE:

The battery charger must be turned off BEFORE removing the battery cable to prevent an over current condition from burning out sensitive control panel components and circuits.

Following all maintenance, reverse these steps to insure the unit is returned to standby setup for normal operation when required.

3.0L GAS ENGINE SERVICE RECOMMENDATIONS

Maintenance Tasks	Level 1	Task Comp. (Date-Initials)	Level 2	Task Comp. (Date-Initials)	Level 3	Task Comp. (Date-Initials)	Level 4	Task Comp. (Date-Initials)
	Recommended to be done monthly/ 10 hrs.		Required to be done 3 months/ Break-in /30 hrs.		Required to be done Semi-Annually/50 hrs.		Required to be done Annually/ 100 hrs.	
1.Disable the unit from operating per the first page warning.	<input type="checkbox"/>		<input type="checkbox"/>		<input type="checkbox"/>		<input type="checkbox"/>	
2.Check the engine oil level. Adjust as necessary.	<input type="checkbox"/>		<input type="checkbox"/>		<input type="checkbox"/>		<input type="checkbox"/>	
3.Check the engine coolant level. Adjust as necessary.	<input type="checkbox"/>		<input type="checkbox"/>		<input type="checkbox"/>		<input type="checkbox"/>	
4.Check the engine coolant thermal protection level. Correct as necessary.							<input type="checkbox"/>	
5.Check the natural gas delivery system on gas engine driven units. Tighten connections as necessary.			<input type="checkbox"/>		<input type="checkbox"/>		<input type="checkbox"/>	
6.Check the diesel fuel supply level for diesel engine driven units. Fill as necessary.	<input type="checkbox"/>		<input type="checkbox"/>		<input type="checkbox"/>		<input type="checkbox"/>	
7.Drain water and sediment from the diesel fuel tank on diesel engine driven units.			<input type="checkbox"/>		<input type="checkbox"/>		<input type="checkbox"/>	
8.Drain water from the fuel line water separator on diesel engine driven units if the unit is equipped with one.			<input type="checkbox"/>		<input type="checkbox"/>		<input type="checkbox"/>	
9.Check the air inlets and outlets for debris. Clean as necessary.	<input type="checkbox"/>		<input type="checkbox"/>		<input type="checkbox"/>		<input type="checkbox"/>	
10.Check the battery electrolyte level if accessible. Adjust as necessary.	<input type="checkbox"/>		<input type="checkbox"/>		<input type="checkbox"/>		<input type="checkbox"/>	
11.Check the battery posts, cables, and charger for loose connections, corrosion, and proper operation. Correct as necessary.	<input type="checkbox"/>		<input type="checkbox"/>		<input type="checkbox"/>		<input type="checkbox"/>	
12.Check the unit wiring for loose connections, corrosion, and damage. Correct as necessary.							<input type="checkbox"/>	
13.Check the engine accessory drive belts for wear, weather cracking, and damage. Replace as necessary.							<input type="checkbox"/>	

3.0L GAS ENGINE SERVICE RECOMMENDATIONS

Maintenance Tasks	Level 1	Task Comp. (Date-Initials)	Level 2	Task Comp. (Date-Initials)	Level 3	Task Comp. (Date-Initials)	Level 4	Task Comp. (Date-Initials)
	Recommended to be done monthly/ 10 hrs.		Required to be done 3 months/ Break-in /30 hrs.		Required to be done Semi-Annually/50 hrs.		Required to be done Annually/ 100 hrs.	
14. Visually inspect the unit looking for leaks, wear or damage, loose connections or components, and corrosion. Correct as necessary.	<input type="checkbox"/>		<input type="checkbox"/>		<input type="checkbox"/>		<input type="checkbox"/>	
15. Test the engine and transfer switch safety devices. Correct and/or adjust as necessary.							<input type="checkbox"/>	
16. Initiate an automatic start and transfer of the unit to site load and exercise it for at least 1 hour looking for leaks, loose connections or components, and abnormal operating conditions. Correct as necessary.			<input type="checkbox"/>		<input type="checkbox"/>			
17. Start and exercise the unit at full rated load (use a load bank if the site load is not enough) for at least 2 hours looking for leaks, loose connections or components, and abnormal operating conditions. Correct as necessary.							<input type="checkbox"/>	
18. Change the engine oil.							<input type="checkbox"/>	
19. Replace the engine oil filter(s).			<input type="checkbox"/>				<input type="checkbox"/>	
20. Replace the engine air filter(s).			<input type="checkbox"/>				<input type="checkbox"/>	
21. Replace the engine fuel filter(s) on diesel engine driven units and re-prime the fuel system.			<input type="checkbox"/>				<input type="checkbox"/>	
22. Check the engine spark plugs on gas engine driven units. Clean and re-gap or replace as necessary.			<input type="checkbox"/>				<input type="checkbox"/>	
23. Perform a 5 minute no-load operational run of the unit looking for any post service problems.			<input type="checkbox"/>				<input type="checkbox"/>	
24. Return the unit to standby setup for operation when required.	<input type="checkbox"/>		<input type="checkbox"/>		<input type="checkbox"/>		<input type="checkbox"/>	

3.0L GAS ENGINE CYLINDER BLOCK & RELATED PARTS

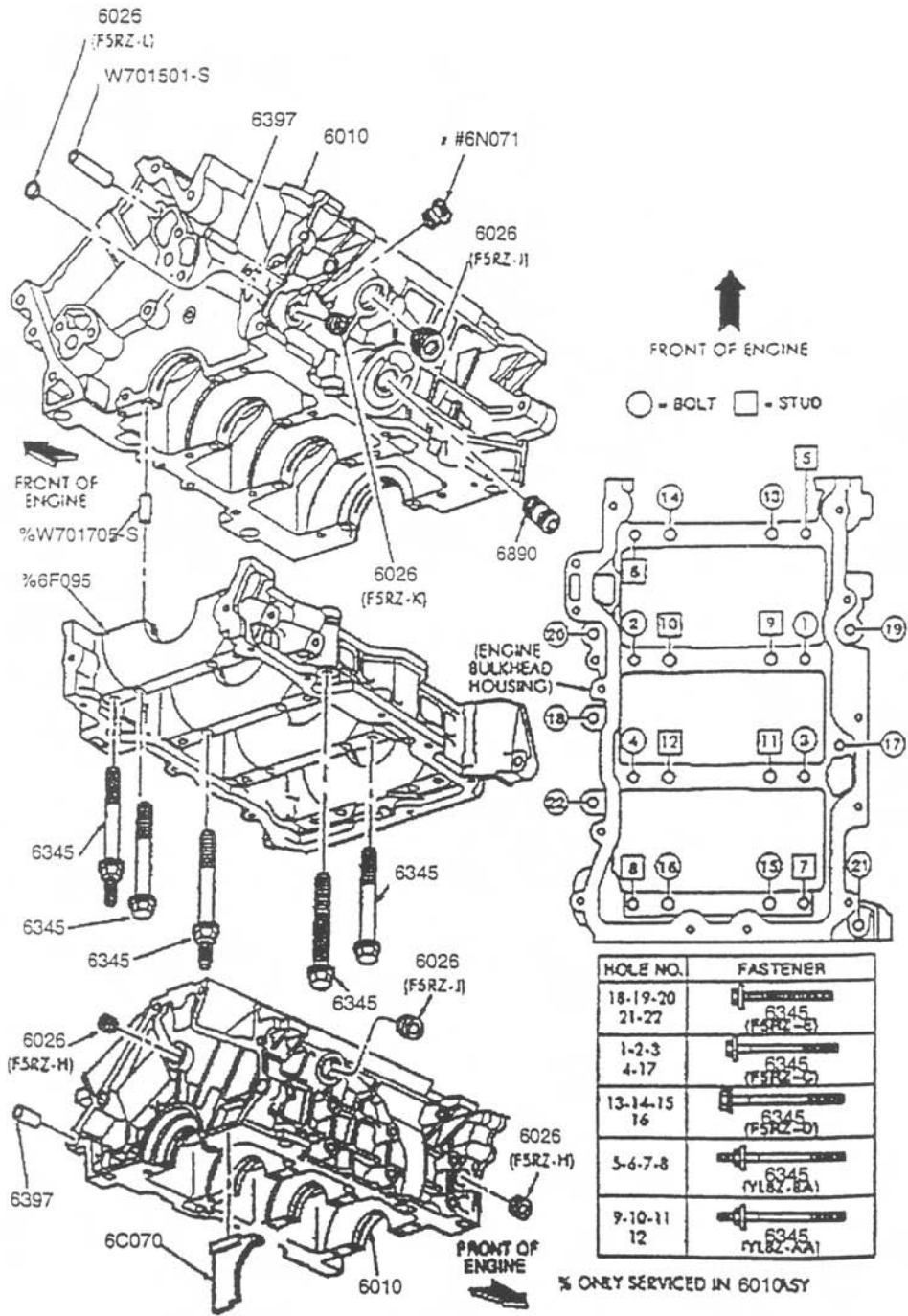

3.0L GAS ENGINE CYLINDER BLOCK & RELATED PARTS

ITEM	PART NUMBER	DESCRIPTION	QTY
		ENGINE BLOCK	
	0F9765	SHORT BLOCK	1
		REMAN ENGINE ASSY	1
6890	0F97650100	OILFILTER MOUNTING INSERT	1
W701501	0F97650101	DOWEL, TIMING CHAIN GUIDE	1
		TIMING COVER	
6019	0F97650102	FRONT TIMING COVER	1
6020	0F97650103	TIMING COVER GASKET, RH	1
6020	0F97650104	TIMING COVER GASKET, CENTER	1
6020	0F97650105	TIMING COVER GASKET, LH	1
6700	0F97650106	TIMING COVER SEAL	1
W701525	0F97650107	BOLT,M8 X 51MM POS.4,10,13,14,15 & 16	6
W701240	0F97650108	BOLT, M8 X 34MM POS.7 & 9	2
W701581	0F97650109	STUD M8 X 68MM X M8 X 2MM POS.2,3,5,6,8,11, & 12	7
W701712	0F97650110	STUD M6 X 20 M8 X 47.5 POS. 1	1
W701228	0F97650111	DOWEL TIMING COVER TO BLOCK	2
		PLUGS-CYLINDER BLOCK	
6026	0F97650112	1/2" X 14 MM PIPE, RG & CENTER REAR OF BLOCK	2
6026	0F97650113	3/4" X 14MM PIPE RH & LH SIDE OF BLOCK	2
6026	0F97650114	3/8" X 18MM PIPE LH SIDE OF BLOCK	1
6026	0F97650115	19.35MM CUP LH SIDE OF BLOCK	1
6026	0F97650116	1 X 11.5MM PIPE RH & LH CYLINDER HEAD	2
6026	0F97650117	1/4" X 18 MM PIPE RH & LH CYLINDER HEAD	9
6391	0F97650118	DOWEL TRANY TO BLOCK	2
		OIL PRESSURE SENDING UNIT	
9278	0F97650119	OIL PRESSURE SENDING UNIT	1
6N071	0F97650120	OIL PRESSURE SENDING UNIT TO BLOCK ADAPTER	1
		MAIN BOLTS	
6345	0F97650121	HOLE # 1,2,3,4 & 17	5
6345	0F97650122	HOLE # 13,14,15,& 16	4
6345	0F97650123	HOLE # 18,19,20,21,& 22	5
6345	0F97650124	HOLE #9,10,11 & 12	4
6345	0F97650125	HOLE #5,6,7,& 8	4

3.0L GAS ENGINE CYLINDER HEAD & RELATED PARTS

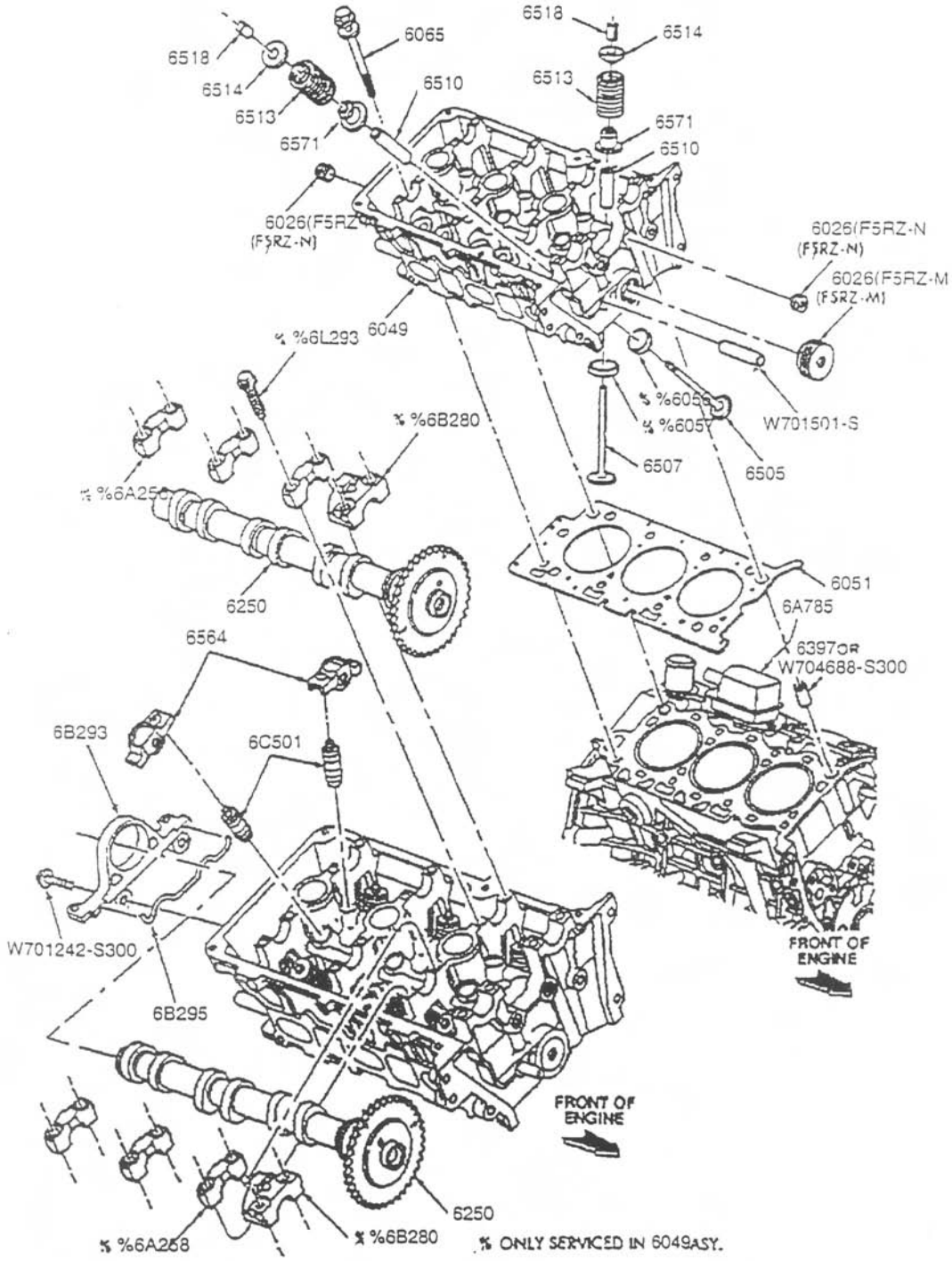

3.0L GAS ENGINE CYLINDER HEAD & RELATED PARTS

ITEM	PART NUMBER	DESCRIPTION	QTY
CYLINDER HEAD ASSEMBLY			
6049	0F97650126	CYL., HEAD, COMPLETE WITH VALVES, LESS CAMS	1
6049	0F97650127	CYL., HEAD, COMPLETE WITH VALVES, LESS CAMS	1
6051	0F97650128	HEAD GASKET, LH	1
6051	0F97650129	HEAD GASKET, RH	1
6065	0F97650130	HEAD BOLT,M10 X 156MM, PKG OF 8	16
VALVES			
6505	0F97650131	EXHAUST VALVE, STANDARD	6
6507	0F97650132	INTAKE VALVE, STANDARD	6
6571	0F97650133	VALVE STEM SEAL, INTAKE	6
VALVE TRAIN			
6513	0F97650134	VALVE SPRING	6
6514	0F97650135	VALVE SPRING RETAINER	12
6518	0F97650136	VALVE SPRING LOCK KEY	24
6564	0F97650137	ROCKER ARM	24
6C501	0F97650138	LASH ADJUSTER	24
6L293	0F97650139	CAMSHAFT BEARING CAP BOLT (NOT REPLACED 11-97) A/R	
CAMSHAFT			
6250	0F97650140	CAMSHAFT, RH INTAKE	1
6250	0F97650141	CAMSHAFT, LH INTAKE	1
6250	0F97650142	CAMSHAFT, RH EXHAUST	1
6250	0F97650143	CAMSHAFT, LH EXHAUST	1
6L253	0F97650144	ARM, TINING CHAIN TENSIONER	2
OIL FILLER / BREATHER / PCV VALVE			
6A785	0F97650145	OIL SEPERATOR ASSEMBLY	1
W701504	0F97650146	BOLT, OIL SEPERATOR	1
6A664	0G0607	CRANKCASE ASPIRATOR HOSE ASSEMBLY	1
6762	0F97650147	ELBOW	1
6A666	0F97650148	PCV VALVE	1

3.0L GAS ENGINE PISTON & CONNECTING ROD

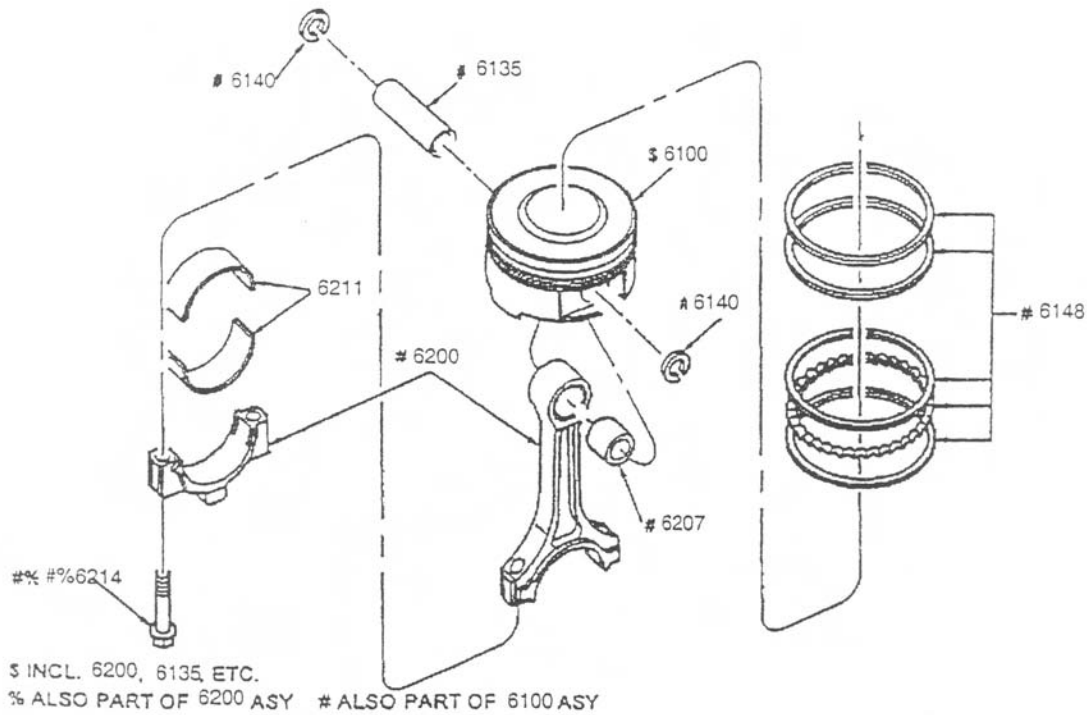

ITEM	PART NUMBER	DESCRIPTION	QTY
PISTON & PIN ASSEMBLY			
6100	0F97650149	PISTON, PIN, RINGS & CONNECTING ROD, STANDARD	6
6148	0F97650150	RINGSET, STANDARD	3
CONNECTING ROD			
6200	0F97650151	CONNECTING ROD	6
6135	0F97650152	PISTON PIN	6
6207	0F97650153	BUSHING, PISTON PIN	6
6140	0F97650154	PISTON PIN RETAINING CLIP	12
6214	0F97650155	BOLT, ROD	12
ROD BEARINGS			
(SOLD IN PACKS OF TWO HALVES)			
6211	0F97650156	ROD BEARING, STANDARD, UPPER & LOWER	12

3.0L GAS ENGINE TIMING COMPONENTS

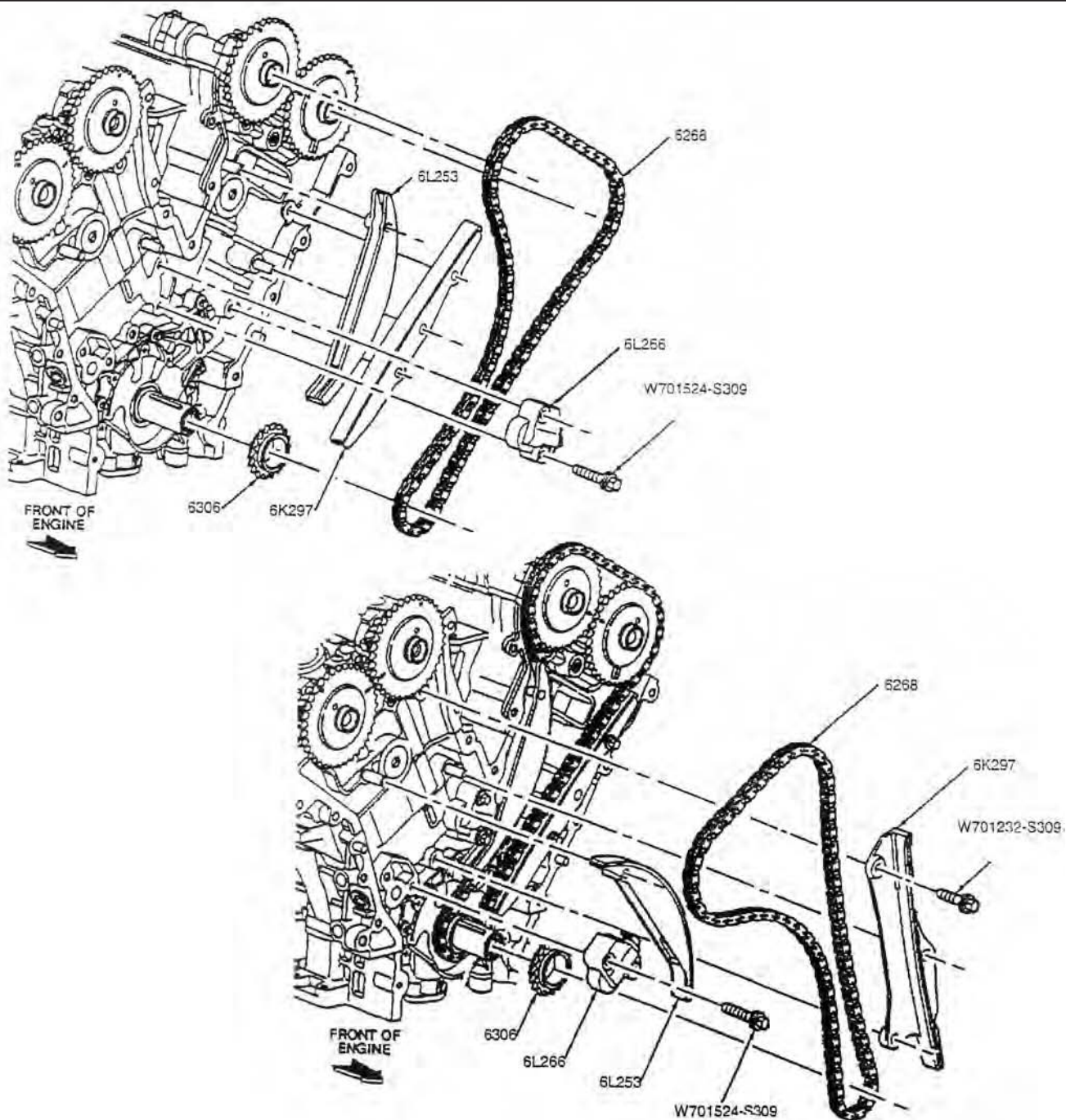

ITEM	PART NUMBER	DESCRIPTION	QTY
6268	0F97650157	TIMING CHAIN, RH OR LH	2
6L253	0F97650158	TENSIONER ARM, RH OR LH	2
6K297	0F97650159	TIMING CHAIN GUIDE, RH	1
6K297	0F97650160	TIMING CHAIN GUIDE, LH	1
6L266	0F97650161	TIMING CHAIN TENSIONER, RH OR LH	2
W701524	0F97650162	BOLT TENSIONER	4
W701232	0F97650163	BOLT, TENSIONER ARM	6
6306	0F97650164	CRANKSHAFT SPROCKET, TWO ROW	1

3.0L GAS ENGINE CRANKSHAFT & RELATED PARTS

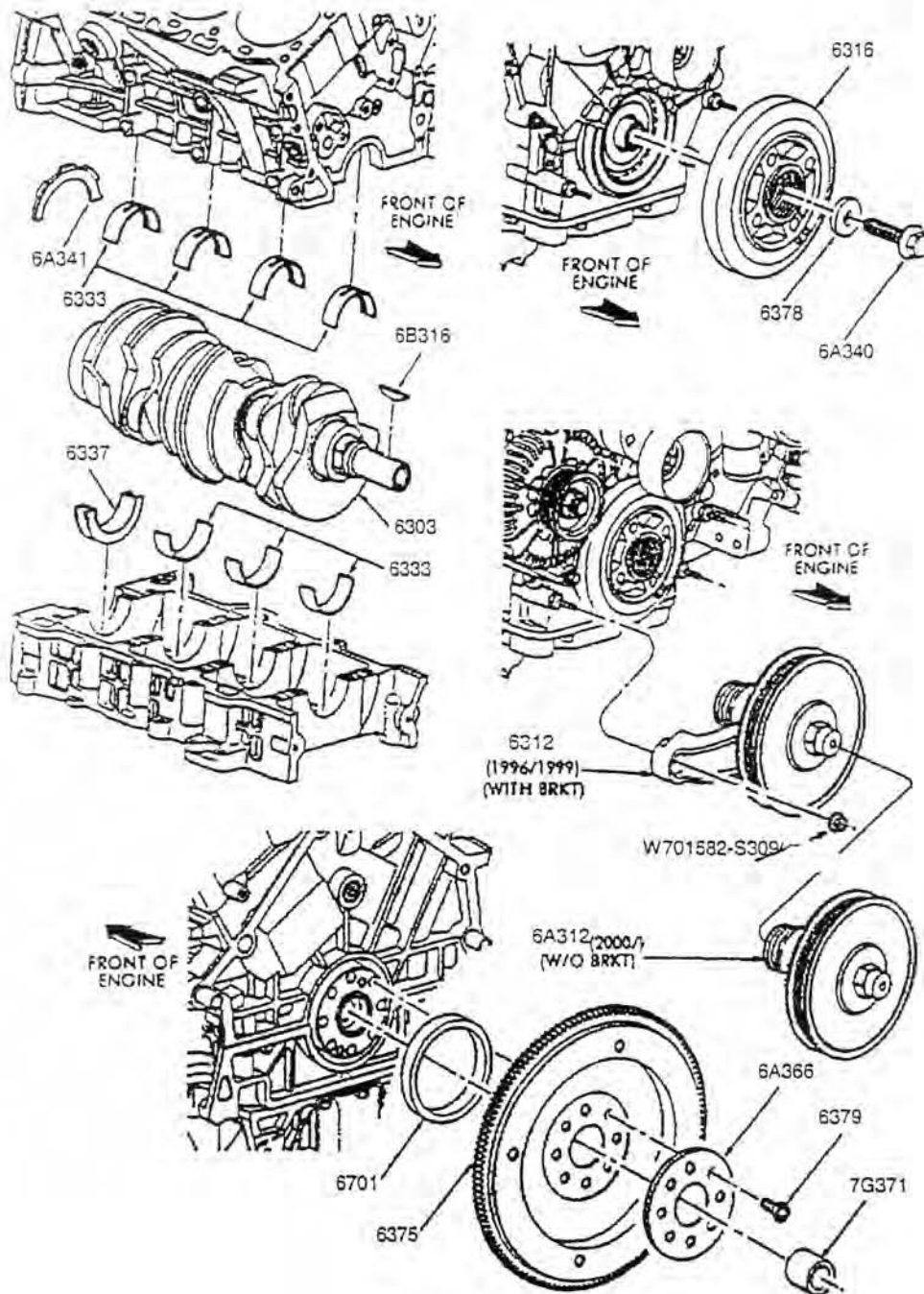

3.0L GAS ENGINE CRANKSHAFT & RELATED PARTS

ITEM	PART NUMBER	DESCRIPTION	QTY
CRANKSHAFT ASSEMBLY			
6303	0F97650165	CRANKSHAFT	1
6B316	0F97650166	CRANKSHAFT KEY	1
12A227	0F97650167	PULSATOR RING, CRANKSHAFT SENSOR	1
6C315	0F97650168	CRANKSHAFT TIMING SENSOR	1
12257	0F97650169	BRACKET, IGNITION MOUNTING	1
18801	0F97650170	CAPACITOR	1
CRANKSHAFT PULLEY			
6316	0F97650171	CRANKSHAFT DAMPER	1
6A340	0F97650172	BOLT, CRANKSHAFT DAMPER	1
6378	0F97650173	WASHER, PULLEY TO CRANKSHAFT	1
6A312	0F97650174	PULLEY, CRANKSHAFT	1
CRANKSHAFT MAIN BEARING KITS			
6D309	0F97650175	MAIN BEARING KIT, STANDARD	1
6D309	0F97650176	MAIN BEARING KIT, .010" UNDERSIZE(25MM)	1
6D309	0F97650177	MAIN BEARING KIT, .020" UNDERSIZE (50MM)	1

3.0L GAS ENGINE OIL PUMP, OIL PAN & RELATED PARTS

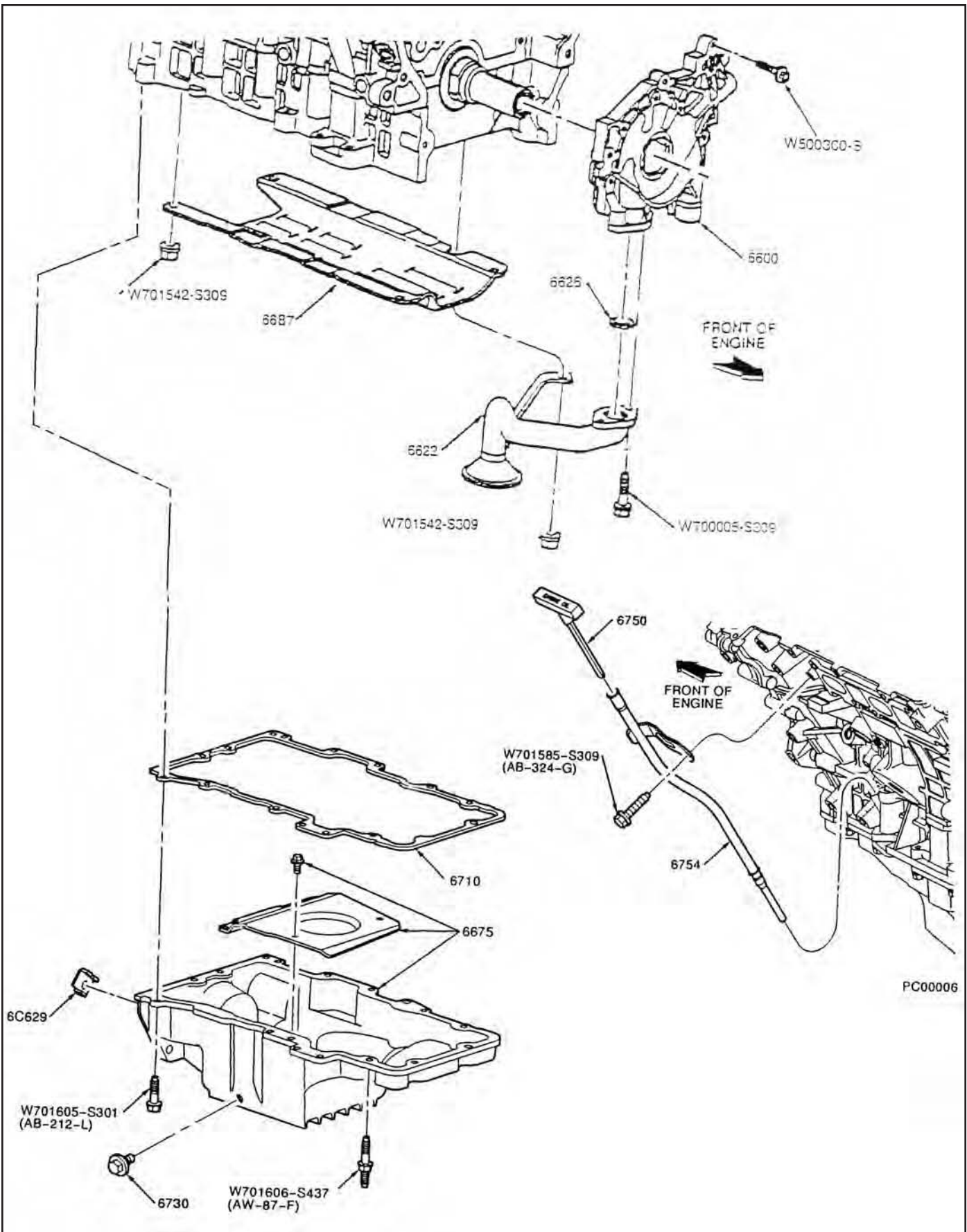

3.0L GAS ENGINE OIL PUMP, OIL PAN & RELATED PARTS

ITEM	PART NUMBER	DESCRIPTION	QTY
OIL PUMP			
6600	0F97650178	OIL PUMP ASSEMBLY	1
W500300	0F97650179	BOLT,PUMP TO BLOCK	4
W700005	0F97650180	BOLT, PICK UP TO PUMP	2
6622	0F97650181	OIL PUMP PICK UP TUBE & SCREEN	1
6626B	0F97650182	OIL PUMP INLET TUBE GASKET	1
OIL PAN			
6675	0F97650183	OIL PAN	1
6687	0F97650184	BAFFLE, OIL PAN	1
W701542	0F97650185	NUT,M6 X 1MM	5
6730	0F97650186	OIL PAN DRAIN PLUG	1
6734	0F97650187	OIL PAN DRAIN PLUG GASKET	1
6710	0F97650188	OIL PAN GASKET	1
W701605	0F97650189	BOLT, OIL PAN	A/R
W701606	0F97650190	STUD OIL PAN	A/R
6754	0F97650191	DIPSTICK TUBE	1
6750	0F97650192	DIPSTICK	1
W701585	0F97650193	BOLT, TUBE TO BLOCK	1
6C629	0F97650194	OIL PAN SPACER,SELECT FIT,YELLOW (#SILVER)	1
6C629	0F97650195	OIL PAN SPACER,SELECT FIT,BLUE (#GOLD)	1
OIL FILTER			
6731	0D5419	OIL FILTER	1

3.0L GAS ENGINE ROCKER COVER & RELATED PARTS

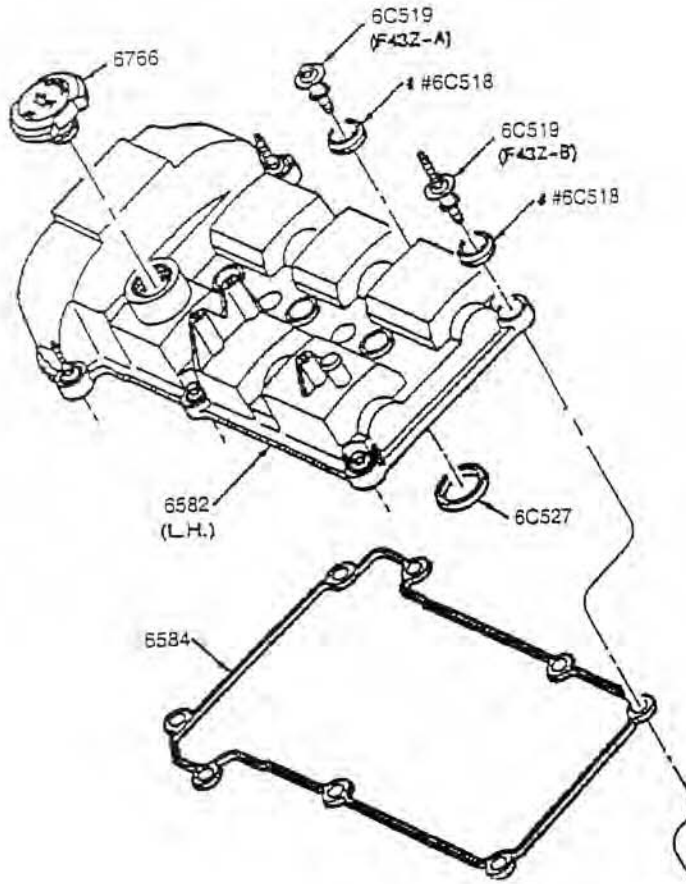

ITEM	PART NUMBER	DESCRIPTION	QTY
6582	0F97650196	ROCKER COVER, RH	1
6582	0F97650197	ROCKER COVER, LH	1
6584	0F97650198	ROCKER COVER GASKET, RH	1
6584	0F97650199	ROCKER COVER GASKET, LH	1
6C519	0F97650200	STUD & GROMMET	1
6C519	0F97650201	BOLT & GROMMET	1
6766	0F97650202	OIL FILLER CAP	1

3.0L GAS ENGINE COOLING SYSTEM

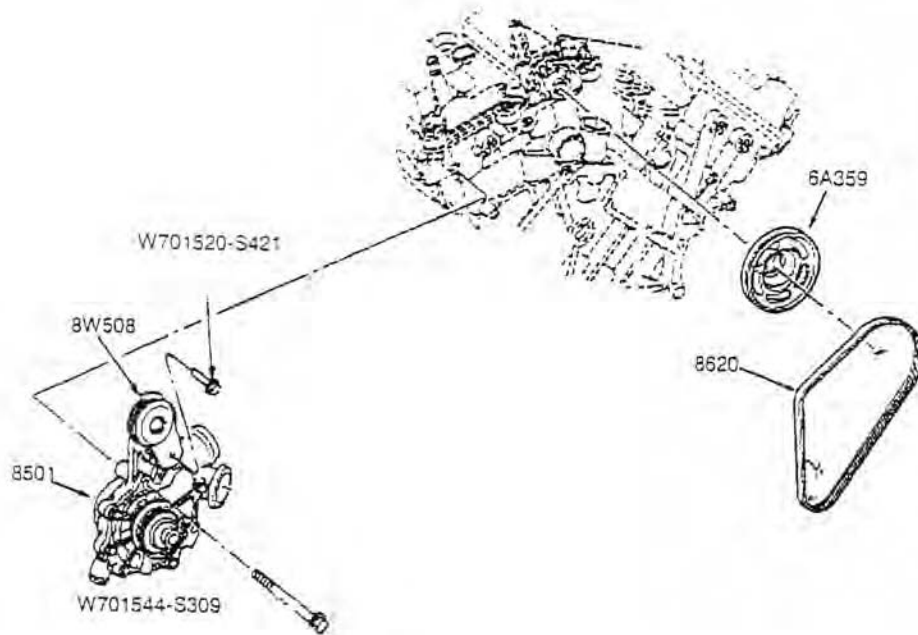

ITEM	PART NUMBER	DESCRIPTION	QTY
8501	0F9225	WATER PUMP	1
8A507	0F97650203	WATER PUMP OUTLET CONNECTION	1
8508	0F97650204	COVER WATER PUMP	1
8A505	0F97650205	INLET WATER TUBE	1
8555	0F97650206	WATERTUBE, CROSSOVER	1
6A312	0F97650207	ACCESSORY DRIVE PULLEY	1
8620	0F9562	BELT, WATER PUMP	1

3.0L GAS ENGINE INTAKE AND EXHAUST MANIFOLD

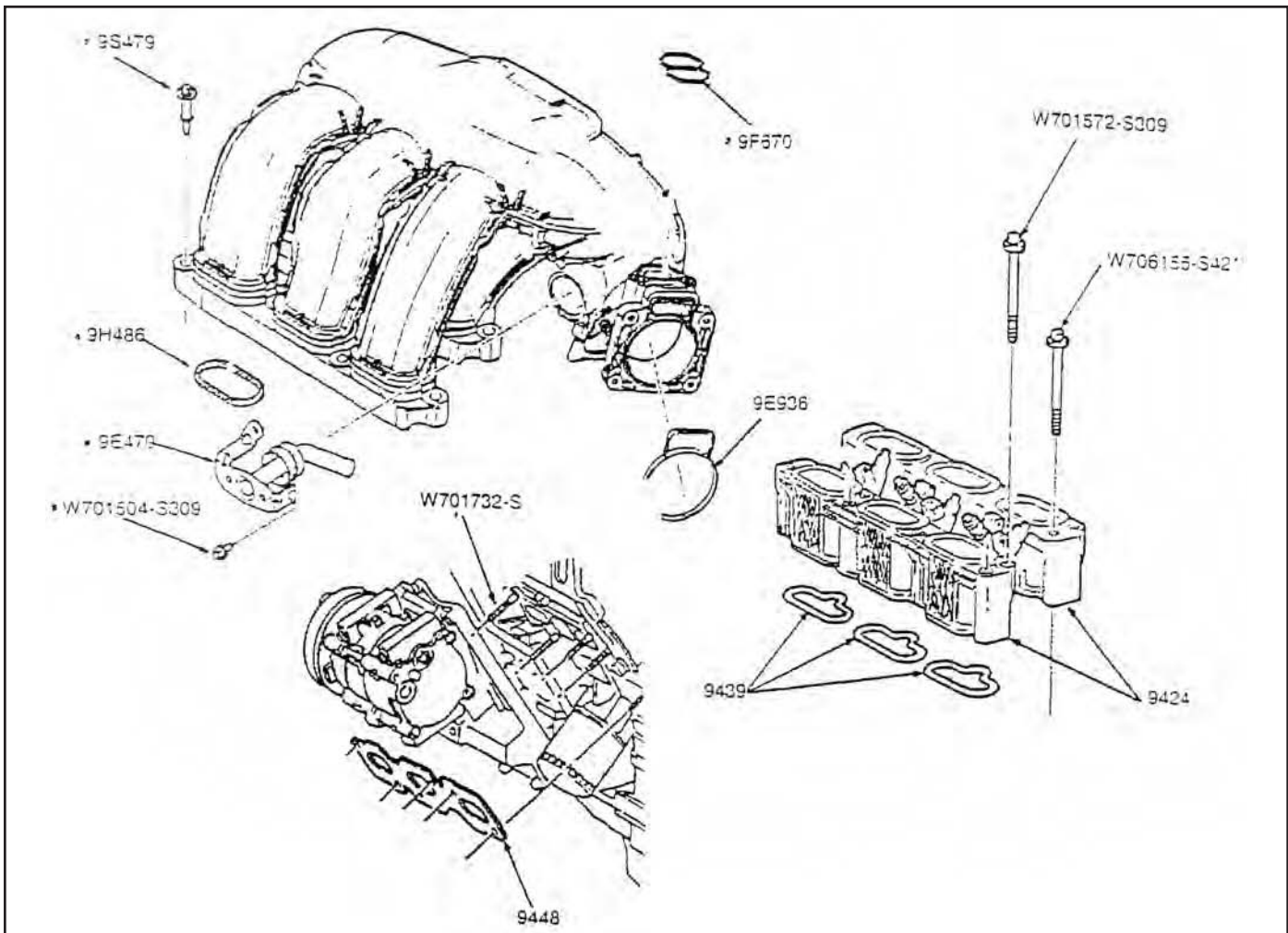

ITEM	PART NUMBER	DESCRIPTION	QTY
INTAKE MANIFOLD			
9424	0F9222	UPPER INTAKE MANIFOLD ASSEMBLY	1
9424	0F9221	LOWER INTAKE MANIFOLD ASSEMBLY	2
9H486	0F9224	GASKETS, UPPER TO LOWER INTAKE MANIFOLD	6
9439	0F9223	GASKETS, LOWER MANIFOLD TO HEAD (PKG OF 6)	2
9E470	0F97650208	TUBE ASSY,EGR VALVE OUTLET	1
W701504	0F97650209	BOLT, EGR TUBE TO UPPER INTAKE MANIFOLD	2
9S479	0F97650210	ISOLATOR ASSY, INTAKE MANIFOLD	1
9F593	0F97650211	INJECTOR	6
9F792	0F97650212	FUEL RAIL	1
9H321	0F97650213	FUEL PRESSURE RELIEF VALVE	1
9H323	0F97650214	FUEL PRESSURE RELIEF VALVE CAP	1
9F972	0F97650215	FUEL INJECTOR SENSOR	1
W500203	0F97650216	SCREW, SENSOR TO RAIL	2
W701572	0F97650217	BOLT,FUEL RAILTO LOWER INTAKE MANIFOLD	4
W708187	0F97650218	BOLT,FUEL RAILTO LOWER INTAKE MANIFOLD	4
EXHAUST MANIFOLD			
9448	0G0100	EXHAUST MANIFOLD GASKET	2
9E498	0F97650219	CONNECTOR, EMISSION VACUMN CNTRL	1
9D476	0F97650220	GASKET EGR VALVE	1
9D477	0F97650221	TUBE , EGR TO EXHAUST MANIFOLD	1
W701732	0F97650222	STUD, EXHAUST MANIFOLD TO HEAD	12
W701706	0F97650223	NUT, EXHAUST MANIFOLD TO HEAD	12

3.0L GAS ENGINE IGNITION

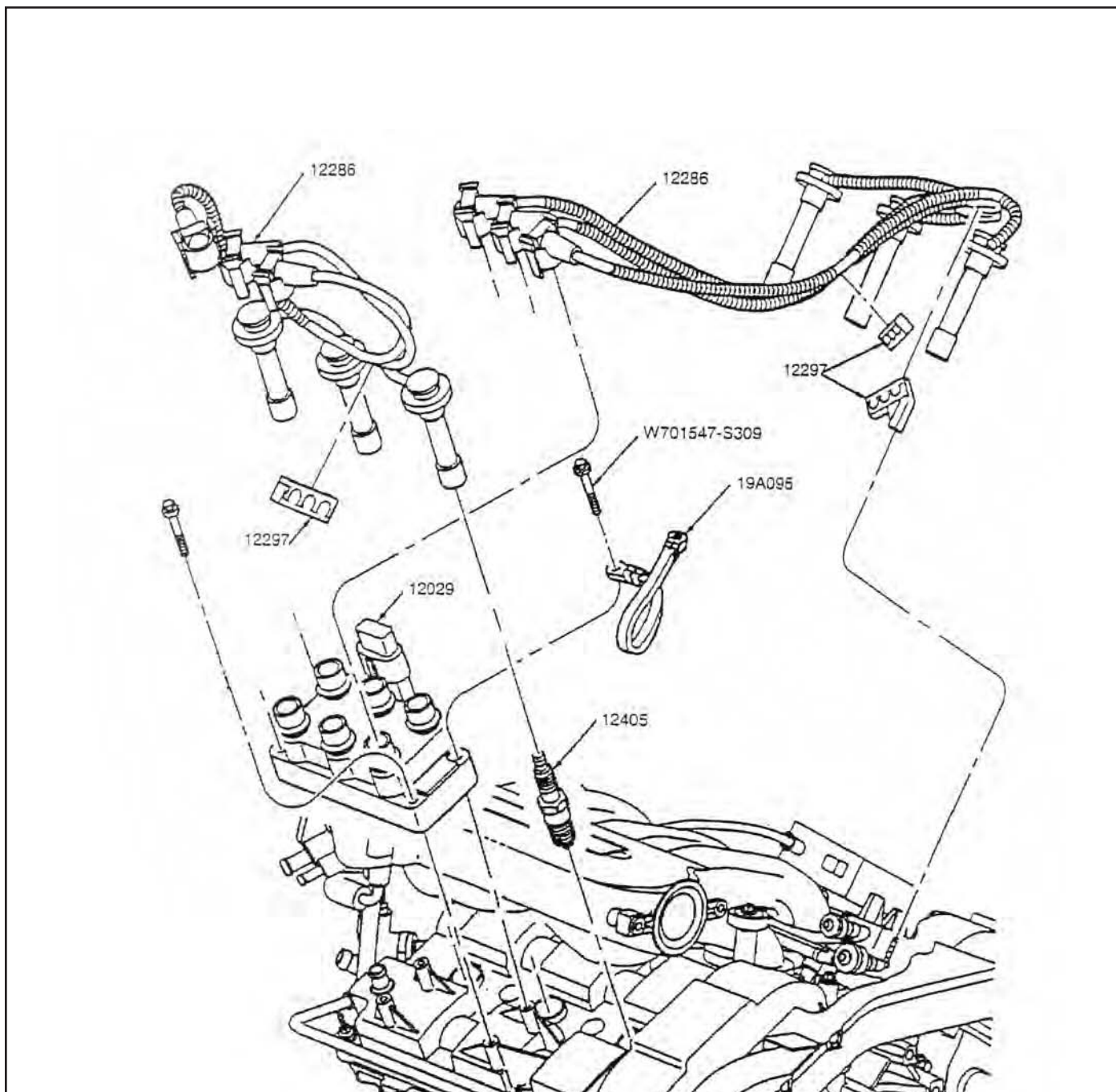

ITEM	PART NUMBER	DESCRIPTION	QTY
12029	0F9228	COIL	1
18801	0F97650224	IGNITION INTERFERENCE CAPACITOR	1
W701547	0F97650225	BOLT, COIL TO ENG, 3/8" 16X.75"	4
	0F97650226	SPARK PLUG	6
12259	0F9556	WIRESET, SPARK PLUGS	1
12297	0F97650227	SEPERATOR, IGNITION WIRE	1
12297	0F97650228	SEPERATOR, IGNITION WIRE	1
12A581	0F97650229	ENGINE CONTROL WIRE HARNESS	1
14536	0F97650230	BRACKET, WIRING	1

3.0L GAS ENGINE COMMON PARTS

GROUP D

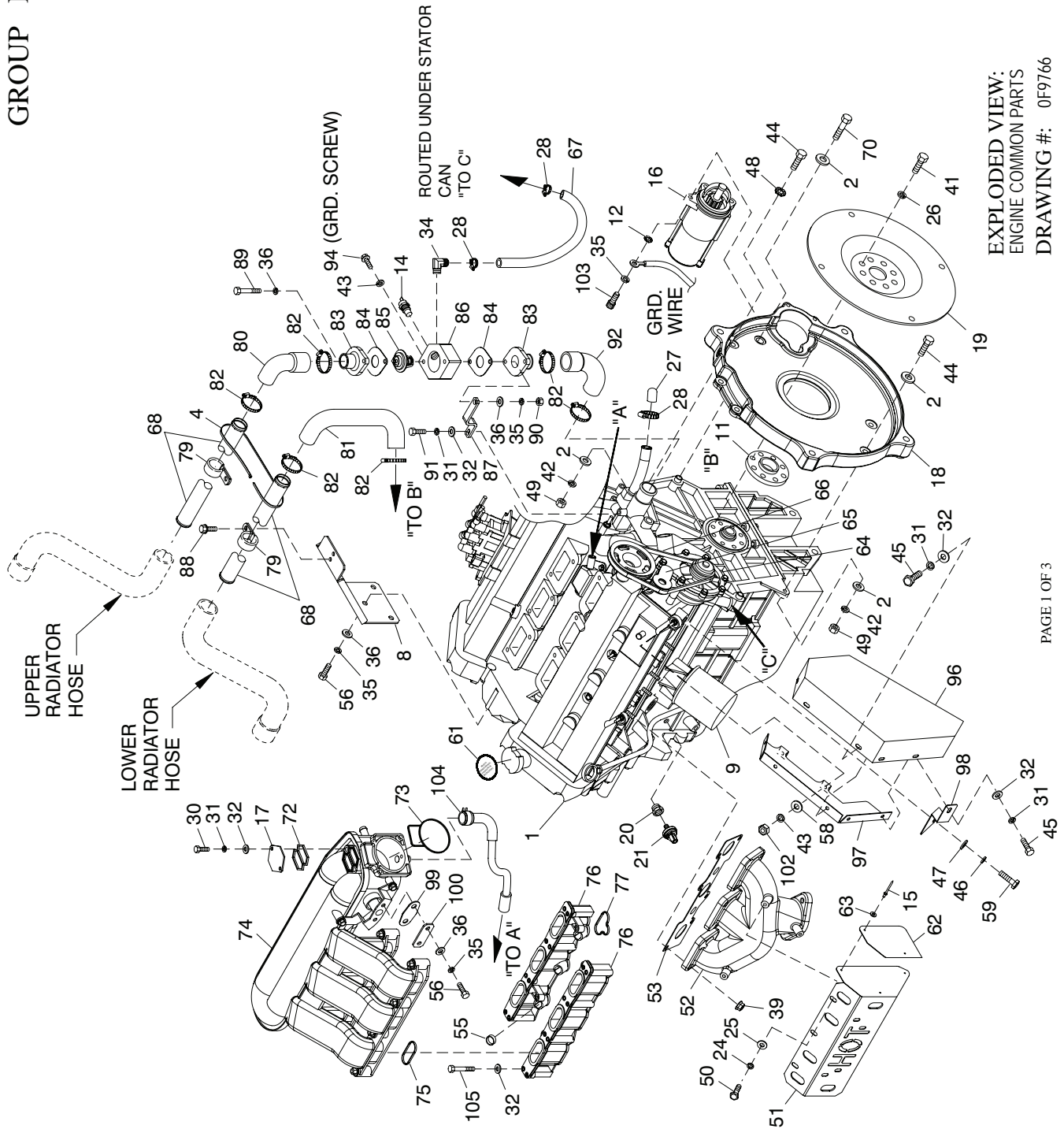

EXPLODED VIEW:
ENGINE COMMON PARTS
DRAWING #: 0F9766

PAGE 1 OF 3

REVISION: G-8403-C
DATE: 6/21/06

3.0L GAS ENGINE COMMON PARTS

ITEM	PART NUMBER	DESCRIPTION	QTY
1	0F9765X	ENGINE FWD MAKE	1
2	022131	WASHER FLAT 3/8-M10 ZINC	5
4	085662D	TIE WRAP UL 17.7 X .35 BLK HT	1
8	0F9258	SUPPORT COOLANT TUBE	1
9	0D5419	(REF.) OIL FILTER	1
11	0F8931	SPACER FLEX PLATE	1
12	027482	WASHER SHAKEPROOF EXT 5/16 STL	1
14	0A6751	SWITCH HI-TEMP 245D X 3/8 NPT	1
15	033472	RIVET POP .125 X .400 AL	6
16	0E9747	STARTER 12 VOLT	1
17	0E6585	COVER IAC ACTUATOR	1
18	0F8425	ADAPTER ENGINE	1
19	0F9965C	FLEX PLATE 2 POLE	1
20	055476	BSHG RDCR HEX 3/8 TO 1/8 GALV	1
21	0A8584	SWITCH OIL PRESSURE 10 PSI 2 POL	1
24	083896	WASHER LOCK 1/4-M6 SS	6
25	084929	WASHER FLAT 1/4 SS	6
26	0F3844	WASHER FLAT .45 X 1.00	8
27	077996	CAP ANTIFREEZE RUBBER	1
28	057823	CLAMP HOSE #10 .56-1.06	3
30	047411	SCREW HHC M6-1.0 X 16 G8.8	2
31	022097	WASHER LOCK M6-1/4	8
32	022473	WASHER FLAT 1/4-M6 ZINC	16
34	0G0153	BARBED EL 90 1/2 NPT X 3/4 HOSE	1
35	022129	WASHER LOCK M8-5/16	14
36	022145	WASHER FLAT 5/16-M8 ZINC	14
39	067989	NUT HEX FL WHIZ M8-1.25	12
41	0D5417	SCREW HHC M10-1.0 X 25 G10.9	8
42	046526	WASHER LOCK M10	3
43	049226	WASHER LOCK M5	8
44	064416	SCREW HHC M10-1.5 X 45 G8.8 FT	6
45	043116	SCREW HHC M6-1.0 X 12 G8.8	5
46	051769	WASHER LOCK M12	1
47	049808	WASHER FLAT M12	1
48	025507	WASHER SHAKEPROOF EXT 7/16 STL	5
49	045772	NUT HEX M10-1.5 G8 YEL CHR	3
50	085296	SCREW HHC 1/4-20 X 1/2 SS	6
51	0E7202	HEAT SHIELD 260 X 80 HOT	2
52	0F8795A	MANIFOLD EXHAUST LH	1
53	0G0100	GASKET EXHAUST	2 (REF.)
55	0E0992A	PLUG EXPANSION 14 OD	6
56	039253	SCREW HHC M8-1.25 X 20 G8.8	5
58	051713	WASHER FLAT M5	2
59	052617	SCREW HHC M12-1.75 X 20 G8.8	1
60	0F9556	WIRES, SPARK PLUG	1

3.0L GAS ENGINE COMMON PARTS

GROUP D

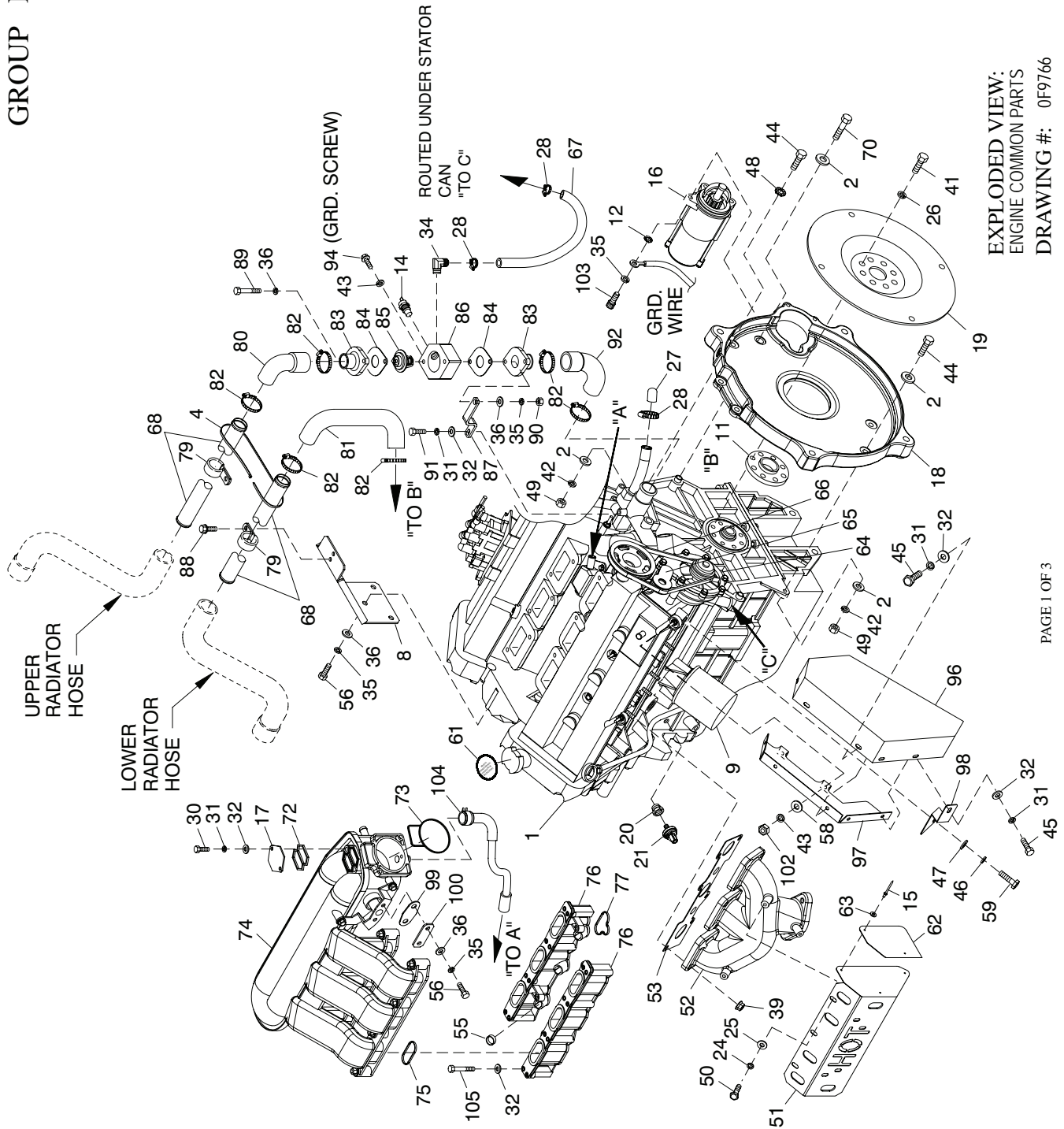

EXPLODED VIEW:
ENGINE COMMON PARTS
DRAWING #: 0F9766

PAGE 1 OF 3

REVISION: G-8403-C
DATE: 6/21/06

3.0L GAS ENGINE COMMON PARTS

ITEM	PART NUMBER	DESCRIPTION	QTY
61	0F5114	DECAL REFER TO OWNERS MANUAL	1
62	0F5966	REFLECTIVE HEAT SHIELD	2
63	022985	WASHER FLAT #6 ZINC	6
64	0F9225	PUMP WATER	1.(REF.)
65	0F9227	TENSIONER WATER PUMP	1
66	0F9562	BELT WATER PUMP	1
67	050968	HOSE COOL 3/4 ID 20R3 (51.5" LG)	1
68	0F6746	TUBE UPPER COOLANT	2
70	052243	SCREW HHC M10-1.5 X 60 G8.8	1
72	0F9563	GASKET IDLE AIR CONTRL ACT CVR	1.(REF.)
73	0F9564	GASKET INTAKE ADAPTER	1.(REF.)
74	0F9222	MANIFOLD INTAKE UPPER	1
75	0F9224	GASKET INTAKE MANIFOLD UPPER	6(REF)
76	0F9221	MANIFOLD INTAKE LOWER	2
77	0F9223	GASKET INTAKE LOWER	6
79	055934V	CLAMP VINYL 1.5 X .281 Z	2
80	0F9220	HOSE UPPR RAD REAR	1
81	0F9239	HOSE,LOWR RAD REAR	1
82	035685	CLAMP HOSE #28 1.32-2.25	6
83	0A2711A	ADAPTER THERMOSTAT	2
84	048665	GASKET THERMOSTAT	2
85	075885	THERMOSTAT 195 DEG	1
86	0F9252	MACHINING,THERMOSTAT ADPTR	1
87	0F9259	BRACKET,THERMOSTAT	1
88	0C2454	SCREW THF M6-1X16 N WA Z/JS	2
89	052207	SCREW HHC M8-1.25 X 80 G8.8	2
92	0F9232	HOSE UPPR RAD REAR	1
96	0F9271	GUARD WATER PUMP REAR	1
97	0F9270	GUARD WATER PUMP FRNT	1
98	0F9314	BRKT WATERPUMP GUARD	1
99	0F7695	EGR GASKET	1
100	0F6658	COVER EGR	1
102	051716	NUT HEX M5-0.8 G8 CLEAR ZINC	4
103	049821	SCREW SHC M8-1.25 X 30 G12.9	
104	0G0607	ASSEMBLY HOSE PCV VALVE	3

3.0L GAS ENGINE COMMON PARTS

ITEM	PART NUMBER	DESCRIPTION	QTY
1	0F9765X	ENGINE FWD MAKE	1
2	022131	WASHER FLAT 3/8-M10 ZINC	5
3*	0F8046	ADAPTER CRANKSHAFT	(REF.)
5	0F9625	BRACKET DC ALTERNATOR	1
6	0E9868A	ALTERNATOR DC W/OUT PULLEY	1
7	0F3216	PULLEY 80 OD DC ALTERNATOR	1
10	0D3488N	BELT SERPENTINE 28.92"	1
13	029187	SPACER .19 X .31 X .50 PL	2
15	033472	RIVET POP .125 X .400 AL	6
22	0C7649	CLAMP HOSE .38-.87	1
23	069860E	HOSE DRAIN ASSY 28"	1
24	083896	WASHER LOCK 1/4-M6 SS	6
25	084929	WASHER FLAT 1/4 SS	6
29	055596	BARBED STR 3/8 NPT X 3/8	1
33	077456	ADAPTER M12-1.75 X 3/8 NPT	1
35	022129	WASHER LOCK M8-5/16	14
36	022145	WASHER FLAT 5/16-M8 ZINC	14
37	052677	WASHER NYLON .50 X .87 X .06	1
38	043107	SCREW HHC M8-1.25 X 25 G8.8	3
39	067989	NUT HEX FL WHIZ M8-1.25	12
40	0F9228	COIL IGNITION	1
42	046526	WASHER LOCK M10	3
43	049226	WASHER LOCK M5	8
49	045772	NUT HEX M10-1.5 G8 YEL CHR	3
50	085296	SCREW HHC 1/4-20 X 1/2 SS	6
51	0E7202	HEAT SHIELD 260 X 80 HOT	2
53	0G0100	GASKET EXHAUST	2 (REF.)
57	0F9617	SPACER ALTERNATOR	1
60	0F9556	WIRES, SPARK PLUG	1
62	0F5966	REFLECTIVE HEAT SHIELD	2
63	022985	WASHER FLAT #6 ZINC	6
69	051731	SCREW HHC M8-1.25 X 50 G8.8	1
93	057645	SCREW HHC M10-1.5 X 50 G8.8	1
95	055440	SCREW HHC M5-0.8 X 25 G8.8	3
101	0F9498	BRACKET COIL	1
102	051716	NUT HEX M5-0.8 G8 CLEAR ZINC	4

GENERAC[®]
POWER SYSTEMS, INC.

Free Manuals Download Website

<http://myh66.com>

<http://usermanuals.us>

<http://www.somanuals.com>

<http://www.4manuals.cc>

<http://www.manual-lib.com>

<http://www.404manual.com>

<http://www.luxmanual.com>

<http://aubethermostatmanual.com>

Golf course search by state

<http://golfingnear.com>

Email search by domain

<http://emailbydomain.com>

Auto manuals search

<http://auto.somanuals.com>

TV manuals search

<http://tv.somanuals.com>