

QUIETSOURCE™

Installation and Owner's Manual

Air-cooled, Prepackaged
Automatic Standby Generators
Model No. 004916-0
(10 kW NG, 11 kW LP)



*This manual should
remain with the unit.



Not intended for use as Primary Power in place of utility or in
life-support applications.



DANGER



DEADLY EXHAUST FUMES. OUTDOOR INSTALLATION ONLY!

INTRODUCTION

Thank you for purchasing this model of the Quiet Source product line by Generac Power Systems Inc. This model is a compact, high performance, air-cooled, engine-driven generator designed to automatically supply electrical power to operate critical loads during a utility power failure.

This unit is factory installed in an all-weather, metal enclosure that is intended exclusively for outdoor installation. This generator will operate using either vapor withdrawn liquid propane (LP) or natural gas (NG).

◆ READ THIS MANUAL THOROUGHLY

If any portion of this manual is not understood, contact the nearest Authorized Dealer for starting, operating and servicing procedures.

NOTE:

A fee may be charged if a service call is made.

Throughout this publication, and on tags and decals affixed to the generator, DANGER, WARNING, CAUTION and NOTE blocks are used to alert personnel to special instructions about a particular operation that may be hazardous if performed incorrectly or carelessly. Observe them carefully. Their definitions are as follows:



After this heading, read instructions that, if not strictly complied with, will result in serious personal injury, including death, in addition to property damage.



After this heading, read instructions that, if not strictly complied with, may result in serious personal injury or property damage.



After this heading, read instructions that, if not strictly complied with, could result in damage to equipment and/or property.

NOTE:

After this heading, read explanatory statements that require special emphasis.

These safety warnings cannot eliminate the hazards that they indicate. Common sense and strict compliance with the special instructions while performing the service are essential to preventing accidents.

Four commonly used safety symbols accompany the DANGER, WARNING and CAUTION blocks. The type of information each indicates follows:

 This symbol points out important safety information that, if not followed, could endanger personal safety and/or property of others.

 This symbol points out potential explosion hazard.

 This symbol points out potential fire hazard.

 This symbol points out potential electrical shock hazard.

The operator is responsible for proper and safe use of the equipment. The manufacturer strongly recommends that the operator read this *Owner's Manual* and thoroughly understand all instructions before using this equipment. The manufacturer also strongly recommends instructing other users to properly start and operate the unit. This prepares them if they need to operate the equipment in an emergency.

◆ CONTENTS

This manual contains pertinent owner's information, including warranty, electrical diagrams, exploded views and lists of repair parts, for model:

- 04916-0 – 10 kW NG, 11 kW LP, V-twin GT-990 Engine

◆ OPERATION AND MAINTENANCE

It is the operator's responsibility to perform all safety checks, to make sure that all maintenance for safe operation is performed promptly, and to have the equipment checked periodically by an Authorized Dealer. Normal maintenance service and replacement of parts are the responsibility of the owner/operator and, as such, are not considered defects in materials or workmanship within the terms of the warranty. Individual operating habits and usage contribute to the need for maintenance service.

Proper maintenance and care of the generator ensures a minimum number of problems and keep operating expenses at a minimum. See an Authorized Dealer for service aids and accessories.

◆ HOW TO OBTAIN SERVICE

When the generator requires servicing or repairs, simply contact an Authorized Dealer for assistance. Service technicians are factory-trained and are capable of handling all service needs.

When contacting an Authorized Dealer about parts and service, always supply the complete model number and serial number of the unit as given on its data decal, which is located on the generator. See Figure 1.3 for decal location.

Model No. _____ Serial No. _____

AUTHORIZED DEALER LOCATION

To locate the nearest AUTHORIZED
DEALER, please call this number:

1-800-333-1322

or locate us on the web at:

www.generac.com

Introduction Inside Front Cover

Read This Manual Thoroughly..... IFC
Contents IFC
Operation and Maintenance..... IFC
How to Obtain Service IFC
Authorized Dealer Locator Number..... IFC

Safety Rules 2

Standards Index..... 3

Section 1 – General Information 4

1.1 Unpacking/Inspection..... 4
1.2 Protection Systems..... 4
1.3 System Set LED 4
1.4 Accessory Features..... 4
 1.4.1 12 Volt DC Outlet..... 4
 1.4.2 120 Volt AC Outlet 5
1.5 The Generator..... 5
1.6 Specifications 6
 1.6.1 Generator..... 6
 1.6.2 Engine..... 6
1.7 Fuel Requirements and Recommendations 7
1.8 Fuel Consumption 7
1.9 Reconfiguring the Fuel System 7
1.10 Location 7
 1.10.1 Generator..... 7
 1.10.2 Transfer Switch 8
1.11 Battery Installation..... 8
1.12 The Battery 8

**Section 2 – Post Installation Start-up
and Adjustments 9**

2.1 Before Initial Startup..... 9
2.2 Check Transfer Switch Operation 9
2.3 Electrical Checks..... 9
2.4 Generator Tests Under Load 10
2.5 Checking Automatic Operation..... 10
2.6 Voltage Regulator Adjustment..... 11

Section 3 – Operation 11

3.1 Break-in Procedure 11
3.2 Using the AUTO/OFF/MANUAL Switch 11
 3.2.1 “Auto” Position 11
 3.2.2 “Off” Position 12
 3.2.3 “Manual” Position..... 12
3.3 Automatic Transfer Operation..... 12
3.4 Sequence of Automatic Operation 12
3.5 Setting the Exercise Timer 13
3.6 Protection Systems..... 13
 3.6.1 Low Oil Pressure Switch 13
 3.6.2 High Temperature Switch..... 13
 3.6.3 Overcrank 13
 3.6.4 Overspeed 13
 3.6.5 Low Battery..... 14

Section 4 – Maintenance..... 14

4.1 System Fuse 14
 4.1.1 7.5 Amp Fuse..... 14
4.2 Checking the Engine Oil Level..... 14
4.3 Changing the Engine Oil..... 14
 4.3.1 Engine Oil Recommendations 14
 4.3.2 Oil Change Procedure 15
4.4 Changing the Oil Filter 15
4.5 Changing the Engine Air Cleaner..... 15
4.6 Spark Plugs..... 15
4.7 Battery Maintenance..... 16
4.8 Adjusting GT-990 Valve Clearance 16
4.9 Cooling System..... 17
4.10 Attention After Submersion..... 17
4.11 Corrosion Protection 17
4.12 Out of Service Procedure..... 17
 4.12.1 Removal From Service 17
 4.12.2 Return to Service 18
4.13 Service Schedule 19

Section 5 – Troubleshooting..... 20

5.1 Troubleshooting Guide..... 20

Section 6 – Installation Diagram..... 21

Section 7 – Electrical Data 22

**Section 8 – Exploded Views and
Parts Lists..... 26**

Section 9 – Notes 38

Section 10 – Warranty 40



⚠ SAVE THESE INSTRUCTIONS – *The manufacturer suggests that these rules for safe operation be copied and posted near the unit's installation site. Safety should be stressed to all operators and potential operators of this equipment.* **⚠**

**WARNING:**

The engine exhaust from this product contains chemicals known to the state of California to cause cancer, birth defects or other reproductive harm.

**WARNING:**

This product contains or emits chemicals known to the state of California to cause cancer, birth defects or other reproductive harm.

Study these SAFETY RULES carefully before installing, operating or servicing this equipment. Become familiar with this *Owner's Manual* and with the unit. The generator can operate safely, efficiently and reliably only if it is properly installed, operated and maintained. Many accidents are caused by failing to follow simple and fundamental rules or precautions.

The manufacturer cannot anticipate every possible circumstance that might involve a hazard. The warnings in this manual, and on tags and decals affixed to the unit are, therefore, not all-inclusive. If using a procedure, work method or operating technique the manufacturer does not specifically recommend, ensure that it is safe for others. Also make sure the procedure, work method or operating technique utilized does not render the generator unsafe.

— **⚠ DANGER ⚠** —

⚠ Despite the safe design of this generator, operating this equipment imprudently, neglecting its maintenance or being careless can cause possible injury or death. Permit only responsible and capable persons to operate or maintain this equipment.

⚠ Potentially lethal voltages are generated by these machines. Ensure all steps are taken to render the machine safe before attempting to work on the generator.

⚠ Parts of the generator are rotating and/or hot during operation. Exercise care near running generators.

⚠ GENERAL HAZARDS ⚠

- For safety reasons, the manufacturer recommends that the installation, initial start-up and maintenance of this equipment is carried out by an Authorized Dealer.
- The engine exhaust fumes contain carbon monoxide, which can be DEADLY. This dangerous gas, if breathed in sufficient concentrations, can cause unconsciousness or even death. This exhaust system must be installed properly, in strict compliance with applicable codes and standards. Following installation, do nothing that might render the system unsafe or in noncompliance with such codes and standards.
- Keep hands, feet, clothing, etc., away from drive belts, fans, and other moving or hot parts. Never remove any drive belt or fan guard while the unit is operating.
- Adequate, unobstructed flow of cooling and ventilating air is critical to correct generator operation. Do not alter the installation or permit even partial blockage of ventilation provisions, as this can seriously affect safe operation of the generator. The generator **MUST** be installed outdoors.
- When working on this equipment, remain alert at all times. Never work on the equipment when physically or mentally fatigued.
- Inspect the generator regularly, and contact the nearest Authorized Dealer for parts needing repair or replacement.
- Before performing any maintenance on the generator, disconnect its battery cables to prevent accidental start up. Disconnect the cable from the battery post indicated by a NEGATIVE, NEG or (–) first. Reconnect that cable last.
- Never use the generator or any of its parts as a step. Stepping on the unit can stress and break parts, and may result in dangerous operating conditions from leaking exhaust gases, fuel leakage, oil leakage, etc.



 ELECTRICAL HAZARDS 

- All generators covered by this manual produce dangerous electrical voltages and can cause fatal electrical shock. Utility power delivers extremely high and dangerous voltages to the transfer switch as does the standby generator when it is in operation. Avoid contact with bare wires, terminals, connections, etc., while the unit is running. Ensure all appropriate covers, guards and barriers are in place before operating the generator. If work must be done around an operating unit, stand on an insulated, dry surface to reduce shock hazard.
- Do not handle any kind of electrical device while standing in water, while barefoot, or while hands or feet are wet. **DANGEROUS ELECTRICAL SHOCK MAY RESULT.**
- The National Electrical Code (NEC) requires the frame and external electrically conductive parts of the generator to be connected to an approved earth ground. Local electrical codes also may require proper grounding of the generator electrical system.
- After installing this home standby electrical system, the generator may crank and start at any time without warning. When this occurs, load circuits are transferred to the STANDBY (GENERATOR) power source. To prevent possible injury if such a start and transfer occur, always set the generator's AUTO/OFF/MANUAL switch to its OFF position before working on equipment and remove the 7.5A and 15A fuses from the generator control panel.
- In case of accident caused by electric shock, immediately shut down the source of electrical power. If this is not possible, attempt to free the victim from the live conductor. **AVOID DIRECT CONTACT WITH THE VICTIM.** Use a nonconducting implement, such as a dry rope or board, to free the victim from the live conductor. If the victim is unconscious, apply first aid and get immediate medical help.
- Never wear jewelry when working on this equipment. Jewelry can conduct electricity resulting in electric shock, or may get caught in moving components causing injury.

 FIRE HAZARDS 

- For fire safety, the generator must be installed and maintained properly. Installation always must comply with applicable codes, standards, laws and regulations. Adhere strictly to local, state and national electrical and building codes. Comply with regulations the Occupational Safety and Health Administration (OSHA) has established. Also, ensure that the generator is installed in accordance with the manufacturer's instructions and recommendations. Following proper installation, do nothing that might alter a safe installation and render the unit in noncompliance with the aforementioned codes, standards, laws and regulations.

- Keep a fire extinguisher near the generator at all times. Extinguishers rated "ABC" by the National Fire Protection Association are appropriate for use on the standby electric system. Keep the extinguisher properly charged and be familiar with its use. Consult the local fire department with any questions pertaining to fire extinguishers.

 EXPLOSION HAZARDS 

- Do not smoke around the generator. Wipe up any fuel or oil spills immediately. Ensure that no combustible materials are left in the generator compartment, or on or near the generator, as FIRE or EXPLOSION may result. Keep the area surrounding the generator clean and free from debris.
- Gaseous fluids such as natural gas and liquid propane (LP) gas are extremely EXPLOSIVE. Install the fuel supply system according to applicable fuel-gas codes. Before placing the home standby electric system into service, fuel system lines must be properly purged and leak tested according to applicable code. After installation, inspect the fuel system periodically for leaks. No leakage is permitted.

◆ STANDARDS INDEX

In the absence of pertinent standards, codes, regulations and laws, the published information listed below may be used as installation guide for this equipment.

1. NFPA No. 37, STATIONARY COMBUSTION ENGINES AND GAS TURBINES, available from the National Fire Protection Association, 470 Atlantic Avenue, Boston, MA 02210.
2. NFPA No. 76A, ESSENTIAL ELECTRICAL SYSTEMS FOR HEALTH CARE FACILITIES, available same as Item 1.
3. NFPA No. 54, NATIONAL FUEL GAS CODE, available same as Item 1.
4. NFPA No. 58, AMERICAN NATIONAL STANDARD FOR STORAGE AND HANDLING OF LIQUEFIED PETROLEUM GAS, available same as Item 1.
5. NFPA No. 70, NFPA HANDBOOK OF NATIONAL ELECTRIC CODE, available same as Item 1.
6. Article X, NATIONAL BUILDING CODE, available from the American Insurance Association, 85 John Street, New York, N.Y. 10038.
7. AGRICULTURAL WIRING HANDBOOK, available from the Food and Energy Council, 909 University Avenue, Columbia, MO 65201.
8. ASAE EP-3634, INSTALLATION AND MAINTENANCE OF FARM STANDBY ELECTRICAL SYSTEMS, available from the American Society of Agricultural Engineers, 2950 Niles Road, St. Joseph, MI 49085.
9. NFPA No. 30, FLAMMABLE AND COMBUSTIBLE LIQUIDS CODE, available same as Item 1.

⚠ DANGER ⚠

⚠ Only qualified electricians or contractors should attempt such installations, which must comply strictly with applicable codes, standards and regulations.

1.1 UNPACKING/INSPECTION

After unpacking, carefully inspect the contents for damage.

- This standby generator set has been factory supplied with a weather protective enclosure that is intended for **outdoor installation only**.

⚠ WARNING ⚠

⚠ If this generator is used to power electrical load circuits normally powered by a utility power source, it is required by code to install a transfer switch. The transfer switch must effectively isolate the electrical system from the utility distribution system when the generator is operating (NEC 700, 701 & 702). Failure to isolate an electrical system by such means will result in damage to the generator and also may result in injury or death to utility power workers due to backfeed of electrical energy.

If any loss or damage is noted at time of delivery, have the person(s) making the delivery note all damage on the freight bill or affix their signature under the consignor's memo of loss or damage.

If a loss or damage is noted after delivery, separate the damaged materials and contact the carrier for claim procedures.

“Concealed damage” is understood to mean damage to the contents of a package that is not in evidence at the time of delivery, but is discovered later.

1.2 PROTECTION SYSTEMS

Unlike an automobile engine, the generator may have to run for long periods of time with no operator present to monitor engine conditions. For that reason, the engine is equipped with the following systems that protect it against potentially damaging conditions:

1. Low Oil Pressure Sensor
2. High Temperature Sensor
3. Overcrank
4. Overspeed
5. Low Battery

There are LED readouts on the control panel to notify the user that one of these faults has occurred. There is also a “System Set” LED that is lit when all of the conditions describe in Section 1.3 are true.

1.3 SYSTEM SET LED

The “System Set” LED is lit when all of the following conditions are true:

1. The AUTO/OFF/MANUAL switch is set to the AUTO position.
2. The utility voltage being supplied to the unit is being sensed by the PCB. If the utility sense voltage is not connected to the unit or if it is below 168 volts AC, then the system set light will flash rapidly. This indicates that if the AUTO/OFF/MANUAL switch is placed in the Auto position, the generator will start.
3. The “Not In Auto” dip switch is set to the OFF position on the control board.
4. No alarms are present, for example, low oil pressure, high temperature, etc.

1.4 ACCESSORY FEATURES

◆ 1.4.1 12 VOLT DC OUTLET

The generator is equipped with a 12 volt DC accessory outlet located in the system control panel (Figure 1.1). With the generator running or in standby mode, this outlet may be used to temporarily power low power accessories such as an inspection light, cell phone, radio or other automotive style accessory with a 7.5 amp maximum current draw.

Figure 1.1 — 12 Volt DC Outlet

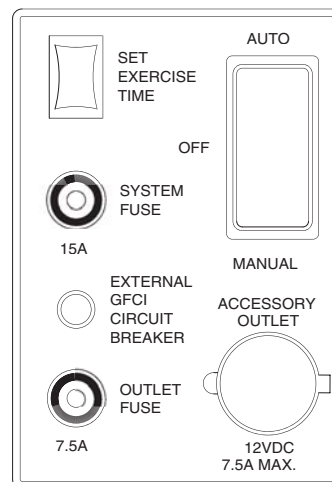

⚠ WARNING ⚠

⚠ The 12 volt DC accessory socket is not intended for continuous use. Power for this socket is drawn from the engine battery. Extended use will drain the battery and the engine may not start. Power available at this socket is limited to 7.5 amps maximum.

◆ 1.4.2 120 VOLT AC OUTLET

The generator is equipped with an external, 15 amp, 120 volt, GFCI convenience outlet located on the front of the unit (Figure 1.2). When the generator is running, in the absence of utility power, this outlet may be used to power items outside the home such as lights or power tools. This outlet may also be used when utility power is present by running the generator in manual mode.

A dedicated push-pull style circuit breaker is located on the control panel for this outlet. Pull the breaker stem out to open the breaker; push in to reset or close the breaker.

Figure 1.2 — 120 Volt AC Outlet

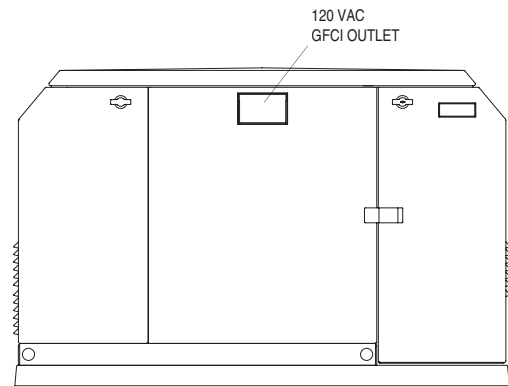

Front View

1.5 THE GENERATOR

Figure 1.3 – 11 kW, V-twin GT-990 Engine

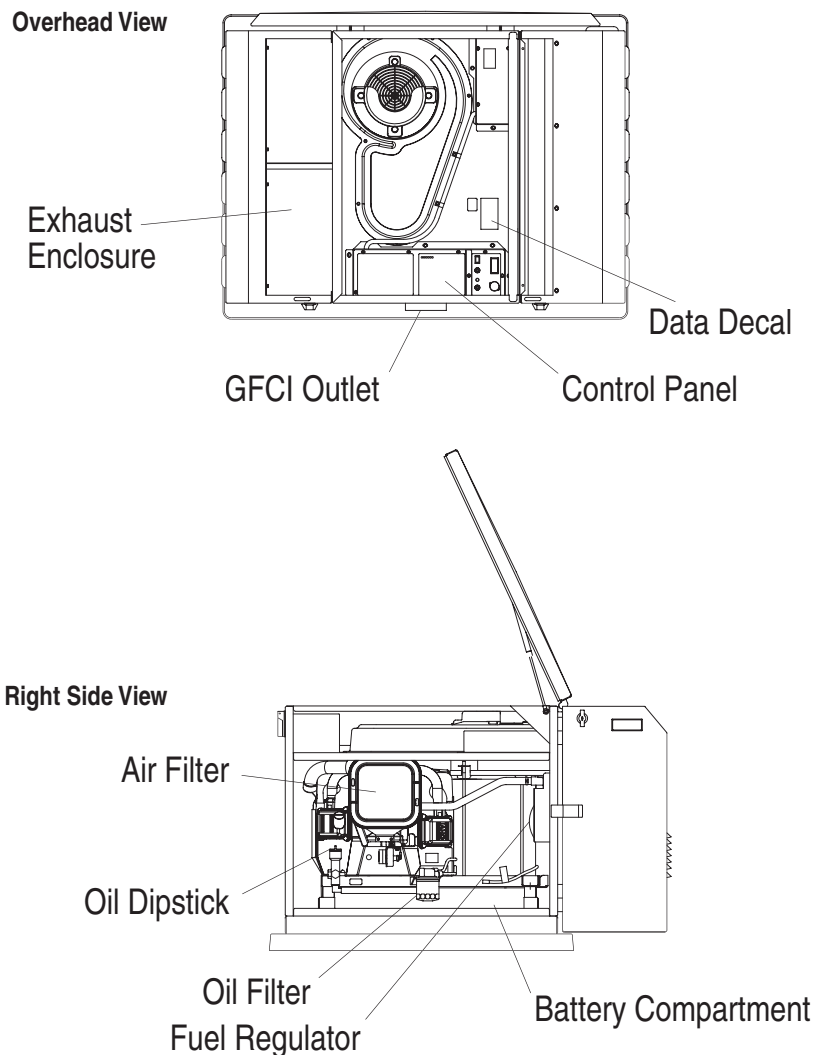

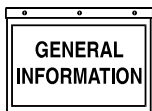

Section 1 – General Information

Air-cooled 11 kW Generators

1.6 SPECIFICATIONS

◆ 1.6.1 GENERATOR

	Model 04916-0
Rated Max. Continuous Power Capacity (Watts*)	10,000 NG/11,000 LP
Rated Voltage	120/240
Rated Max. Continuous Load Current (Amps)	
120 Volts**	83.3 NG/91.7 LP
240 Volts	41.7 NG/45.8 LP
Main Line Circuit Breaker	45 Amp
Phase	1
Number of Rotor Poles	2
Rated AC Frequency	60 Hz
Power Factor	1
Recommended Air Filter	Part # C8127
Battery Requirement at -17.8° C (0° F)	Group 26/26R 12 Volts and 525 Cold-cranking Amperes Minimum
Weight	495 Pounds
Output Sound Level @ 23 ft (7m) at full load	62.2 db (A)
Normal Operating Range	-20°F (-28.8°C) to 104°F (40°C)

* Maximum wattage and current are subject to and limited by such factors as fuel Btu content, ambient temperature, altitude, engine power and condition, etc. Maximum power decreases about 3.5 percent for each 1,000 feet above sea level; and also will decrease about 1 percent for each 6° C (10° F) above 16° C (60° F) ambient temperature.

** Load current values shown for 120 volts are maximum TOTAL values for two separate circuits. The maximum current in each circuit must not exceed the value stated for 240 volts.

◆ 1.6.2 ENGINE

	Model 04916-0
Type of Engine	GT-990
Number of Cylinders	2
Rated Horsepower	30 @ 3,600 rpm
Displacement	992cc
Cylinder Block	Aluminum w/Cast Iron Sleeve
Valve Arrangement	Overhead Valves
Ignition System	Solid-state w/Magneto
Recommended Spark Plug	RC14YC
Spark Plug Gap	0.76 mm (0.030 inch)
Compression Ratio	9.5:1
Starter	12Vdc
Oil Capacity Including Filter	Approx. 1.7 Qts
Recommended Oil Filter	Part # 70185
Recommended Air Filter	Part # 0C8127
Operating RPM	2,700

1.7 FUEL REQUIREMENTS AND RECOMMENDATIONS

With LP gas, use only the vapor withdrawal system. This type of system uses the vapors formed above the liquid fuel in the storage tank.

The engine has been fitted with a fuel carburetion system that meets the specifications of the 1997 California Air Resources Board for tamper-proof dual fuel systems. The unit will run on natural gas or LP gas, but it has been factory set to run on natural gas. Should the primary fuel need to be changed to LP gas, the fuel system needs to be reconfigured. See Section 1.8 for instructions on reconfiguration of the fuel system.

Recommended fuels should have a Btu content of at least 1,000 Btus per cubic foot for natural gas; or at least 2,520 Btus per cubic foot for LP gas. Ask the fuel supplier for the Btu content of the fuel.

Required fuel pressure for **natural gas is 5 inches to 7 inches water column (0.18 to 0.25); and for liquid propane vapor, 10 inches to 12 inches of water column (0.36 to 0.43 psi).**

⚠ WARNING ⚠

⚠ A separate gas line and regulator may be needed to assure proper gas pressure to the generator. Low gas pressure can cause hard starting and could affect engine durability.

1.8 FUEL CONSUMPTION

Model #	Nat. Gas (*)		LP Vapor (**)	
	1/2 Load	Full Load	1/2 Load	Full Load
04916	115	202	1.38/55.6	2.15/86.4

*Natural gas is in cubic feet per hour.

**LP is in gallons per hour/cubic feet per hour.

⚠ DANGER ⚠

⚠ Gaseous fuels such as natural gas and liquid propane (LP) gas are highly explosive. Even the slightest spark can ignite such fuels and cause an explosion. No leakage of fuel is permitted. Natural gas, which is lighter than air, tends to collect in high areas. LP gas is heavier than air and tends to settle in low areas.

1.9 RECONFIGURING THE FUEL SYSTEM

To reconfigure the fuel system from NG to LP, follow these steps:

1. Turn the main gas supply off.
2. Remove the carburetor fuel hose and the brass hose fitting from the NG (right) outlet port of the demand regulator (Figure 1.4).

3. Remove the pipe plug from the LP (left) outlet port.
4. Install the brass hose fitting in the LP (left) outlet port.
5. Install the pipe plug in the NG (right) outlet port.
6. Connect the carburetor fuel hose to the LP (left) outlet port of the demand regulator.
7. Reverse the procedure to convert back to natural gas.

Figure 1.4 – Demand Regulator

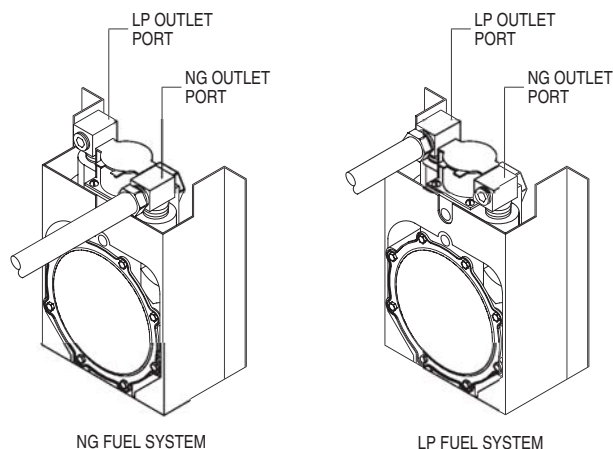

1.10 LOCATION

◆ 1.10.1 GENERATOR

Install the generator set, in its protective enclosure, outdoors, where adequate cooling and ventilating air is always available. Consider these factors:

- Install the unit where air inlet and outlet openings will not become obstructed by leaves, grass, snow, etc. If prevailing winds will cause blowing or drifting, consider using a windbreak to protect the unit.
- Install the generator on high ground where water levels will not rise and endanger it.
- Allow sufficient room on all sides of the generator for maintenance and servicing. A good rule is to allow three feet of space on all sides.
- Where strong prevailing winds blow from one direction, face the generator air inlet openings to the prevailing winds.
- Install the generator as close as possible to the fuel supply, to reduce the length of piping.
- Install the generator as close as possible to the transfer switch. HOWEVER, REMEMBER THAT LAWS OR CODES MAY REGULATE THE DISTANCE.

The genset must be installed on a level surface. The base frame must be level within two (2) inches all around.

◆ 1.10.2 TRANSFER SWITCH

This generator should only be installed with a compatible transfer switch. A range of transfer switches are offered by the manufacturer.

1.11 BATTERY INSTALLATION

▲ WARNING ▲

▲ If the AUTO/OFF/MANUAL switch is not set to its OFF position, the generator can crank and start as soon as the battery cables are connected. If the utility power supply is not turned off, sparking can occur at the battery posts and cause an explosion.

Fill the battery with the proper electrolyte fluid if necessary and have the battery fully charged before installing it.

Before installing and connecting the battery, complete the following steps:

1. Set the generator's AUTO/OFF/MANUAL switch to OFF.
2. Turn off utility power supply to the transfer switch.
3. Remove the 7.5A and 15A fuses from the generator control panel.

Battery cables were factory connected at the generator (Figure 1.5). Connect cables to battery posts as follows:

4. Connect the red battery cable (from starter contactor) to the battery post indicated by a positive, POS or (+).
5. Connect the black battery cable (from frame ground) to the battery post indicated by a negative, NEG or (—).

NOTE:

Damage will result if battery connections are made in reverse.

Figure 1.5 – Battery Cable Connections

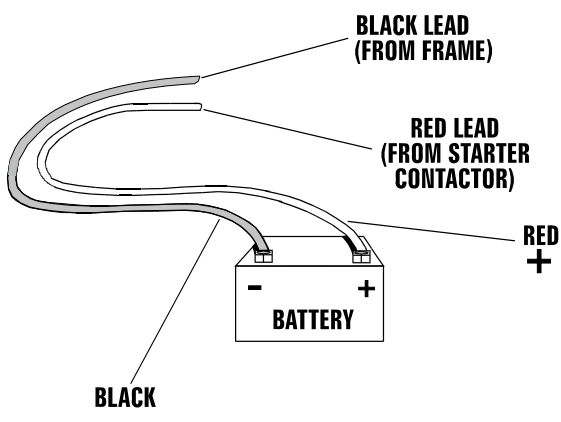

NOTE:

The generator is equipped with a battery trickle charger that is active when the unit is set up for automatic operation. With the battery installed and utility power source voltage available to the transfer switch, the battery receives a trickle charge while the engine is not running, to prevent self-discharge. The trickle charger is designed to help extend the life of the battery by maintaining the battery when the unit is not running. The trickle charge feature cannot be used to recharge a discharged battery.

1.12 THE BATTERY

Servicing of the battery is to be performed or supervised by personnel knowledgeable of batteries and the required precautions. Keep unauthorized personnel away from batteries.

When replacing the battery, use the following type of battery: Group 26/26R 12-volt DC, negative ground battery with a rating of 525 cold-cranking amps minimum at -17.8° C (0° F). When using a maintenance-free battery, it is not necessary to check the specific gravity or electrolyte level. Have these procedures performed at the intervals specified in the "Service Schedule." A negative ground system is used. Battery connections are shown on the wiring diagrams. Make sure the battery is correctly connected and terminals are tight. Observe battery polarity when connecting the battery to the generator set.

▲ DANGER ▲

- ▲ Do not dispose of the battery in a fire. The battery is capable of exploding.
- ▲ A battery presents a risk of electrical shock and high short circuit current. The following precautions are to be observed when working on batteries:
 - Remove the 7.5A and 15A fuses from the generator control panel.
 - Remove watches, rings or other metal objects;
 - Use tools with insulated handles;
 - Wear rubber gloves and boots;
 - Do not lay tools or metal parts on top of the battery; and
 - Disconnect charging source prior to connecting or disconnecting battery terminals.

▲ WARNING ▲

- ▲ Do not open or mutilate the battery. Released electrolyte has been known to be harmful to the skin and eyes, and to be toxic.
- ▲ The electrolyte is a dilute sulfuric acid that is harmful to the skin and eyes. It is electrically conductive and corrosive.

The following procedures are to be observed:

- Wear full eye protection and protective clothing;
- Where electrolyte contacts the skin, wash it off immediately with water;
- Where electrolyte contacts the eyes, flush thoroughly and immediately with water and seek medical attention; and
- Spilled electrolyte is to be washed down with an acid neutralizing agent. A common practice is to use a solution of 1 pound (500 grams) bicarbonate of soda to 1 gallon (4 liters) of water. The bicarbonate of soda solution is to be added until the evidence of reaction (foaming) has ceased. The resulting liquid is to be flushed with water and the area dried.

 Lead-acid batteries present a risk of fire because they generate hydrogen gas. The following procedures are to be followed:

- DO NOT SMOKE when near the battery;
- DO NOT cause flame or spark in battery area; and
- Discharge static electricity from body before touching the battery by first touching a grounded metal surface.

 Be sure the AUTO/OFF/MANUAL switch is set to the OFF position before connecting the battery cables. If the switch is set to AUTO or MANUAL, the generator can crank and start as soon as the battery cables are connected.

 Be sure the utility power supply is turned off and the 7.5A and 15A fuses are removed from the generator control panel, or sparking may occur at the battery posts as the cables are attached and cause an explosion.

2.1 BEFORE INITIAL START-UP

Before starting, complete the following:

1. Set the generator's main circuit breaker to its OFF (or OPEN) position.
2. Set the generator's AUTO/OFF/MANUAL switch to the OFF position.
3. Turn OFF the utility power supply to the transfer switch using the means provided (such as the utility main line circuit breaker).
4. Turn OFF all loads connected to the transfer switch terminals T1 and T2.
5. Check the engine crankcase oil level and, if necessary, fill to the dipstick FULL mark with the recommended oil. Do not fill above the FULL mark.
6. Check the fuel supply. Gaseous fuel lines must have been properly purged and leak tested in accordance with applicable fuel-gas codes. All fuel shutoff valves in the fuel supply lines must be open.

—  CAUTION  —

 Never operate the engine with the oil level below the "ADD" mark on the dipstick. Doing this could damage the engine.

2.2 CHECK TRANSFER SWITCH OPERATION

Refer to the transfer switch owner's manual for manual operation procedures.

—  DANGER  —

 Do not attempt manual transfer switch operation until all power voltage supplies to the transfer switch have been positively turned off. Failure to turn off all power voltage supplies will result in extremely hazardous and possibly fatal electrical shock.

2.3 ELECTRICAL CHECKS

Complete electrical checks as follows:

1. Set the generator's main circuit breaker to its OFF (or open) position.
2. Set the generator's AUTO/OFF/MANUAL switch to the OFF position.
3. Turn OFF all loads connected to the transfer switch terminals T1 and T2.
4. Turn on the utility power supply to the transfer switch using the means provided (such as a utility main line circuit breaker).

—  DANGER  —

 The transfer switch is now electrically "hot." Contact with "hot" parts will result in extremely hazardous and possibly fatal electrical shock. Proceed with caution.

5. Use an accurate AC voltmeter to check utility power source voltage across transfer switch terminals N1 and N2. Nominal line-to-line voltage should be 240 volts AC.
6. Check utility power source voltage across terminals N1 and the transfer switch neutral lug; then across terminal N2 and neutral. Nominal line-to-neutral voltage should be 120 volts AC.
7. When certain that utility supply voltage is compatible with transfer switch and load circuit ratings, turn OFF the utility power supply to the transfer switch.
8. On the generator panel, set the AUTO/OFF/MANUAL switch to MANUAL. The engine should crank and start.
9. Let the engine warm up for about five minutes to allow internal temperatures to stabilize. Then, set the generator's main circuit breaker to its ON (or closed) position.

⚠ DANGER ⚠

⚠ Proceed with caution! Generator power voltage is now supplied to the transfer switch. Contact with live transfer switch parts will result in dangerous and possibly fatal electrical shock.

10. Connect an accurate AC voltmeter and a frequency meter across transfer switch terminal lugs E1 and E2. Voltage should be 242-252 volts; frequency should read about 61-63 Hertz.
11. Connect the AC voltmeter test leads across terminal lug E1 and neutral; then across E2 and neutral. In both cases, voltage reading should be 121-126 volts AC.
12. Set the generator's main circuit breaker to its OFF (or open) position. Let the engine run at no-load for a few minutes to stabilize internal engine generator temperatures.
13. Set the generator's AUTO/OFF/MANUAL switch to OFF. The engine should shut down.

NOTE:

It is important not to proceed until certain that generator AC voltage and frequency are correct and within the stated limits. Generally, if both AC frequency and voltage are high or low, the engine governor requires adjustment. If frequency is correct, but voltage is high or low, the generator's voltage regulator requires adjustment.

2.4 GENERATOR TESTS UNDER LOAD

To test the generator set with electrical loads applied, proceed as follows:

1. Set generator's main circuit breaker to its OFF (or open) position.
2. Turn OFF all loads connected to the transfer switch terminals T1 and T2.
3. Set the generator's AUTO/OFF/MANUAL switch to OFF.
4. Turn OFF the utility power supply to the transfer switch, using the means provided (such as a utility main line circuit breaker).

⚠ WARNING ⚠

⚠ Do not attempt manual transfer switch operation until all power voltage supplies to the transfer switch have been positively turned off. Failure to turn off all power voltage supplies will result in extremely hazardous and possibly fatal electrical shock.

5. Manually set the transfer switch to the STANDBY position, e.g., load terminals connected to the generator's E1/E2 terminals. The transfer switch operating lever should be down.

6. Set the generator's AUTO/OFF/MANUAL switch to MANUAL. The engine should crank and start immediately.
7. Let the engine stabilize and warm up for a few minutes.
8. Set the generator's main circuit breaker to its ON (or closed) position. Loads are now powered by the standby generator.
9. Turn ON electrical loads connected to transfer switch T1 and T2. Apply an electrical load equal to the full rated wattage/ampere capacity of the installed generator.
10. Connect an accurate AC voltmeter and a frequency meter across terminal lugs E1 and E2. Voltage should be greater than 230 volts; frequency should be greater than 58 Hertz.
11. Let the generator run at full rated load for 20-30 minutes. Listen for unusual noises, vibration or other indications of abnormal operation. Check for oil leaks, evidence of overheating, etc.
12. When testing under load is complete, turn OFF electrical loads.
13. Set the generator's main circuit breaker to its OFF (or open) position.
14. Let the engine run at no-load for a few minutes.
15. Set the AUTO/OFF/MANUAL switch to OFF. The engine should shut down.

2.5 CHECKING AUTOMATIC OPERATION

To check the system for proper automatic operation, proceed as follows:

1. Set generator's main circuit breaker to its OFF (or open) position.
2. Check that the AUTO/OFF/MANUAL switch is set to OFF.
3. Turn OFF the utility power supply to the transfer switch, using means provided (such as a utility main line circuit breaker).
4. Manually set the transfer switch to the UTILITY position, i.e., load terminals connected to the utility power source side.
5. Turn ON the utility power supply to the transfer switch, using the means provided (such as a utility main line circuit breaker).
6. Set the AUTO/OFF/MANUAL switch to AUTO. The system is now ready for automatic operation.
7. Turn OFF the utility power supply to the transfer switch.

With the AUTO/OFF/MANUAL switch at AUTO, the engine should crank and start when the utility source power is turned OFF. After starting, the transfer switch should connect load circuits to the standby side. Let the system go through its entire automatic sequence of operation.

With the generator running and loads powered by generator AC output, turn ON the utility power supply to the transfer switch. The following should occur:

- After about six seconds, the switch should transfer loads back to the utility power source.
- About one minute after retransfer, the engine should shut down.

2.6 VOLTAGE REGULATOR ADJUSTMENT

With the frequency between 60-60.5 Hertz, slowly turn the slotted potentiometer (Figure 2.1) until line voltage reads 247-252 volts.

NOTE:

The access panel on top of the control panel must be removed to adjust the voltage regulator.

Figure 2.1 – Voltage Adjustment Potentiometer

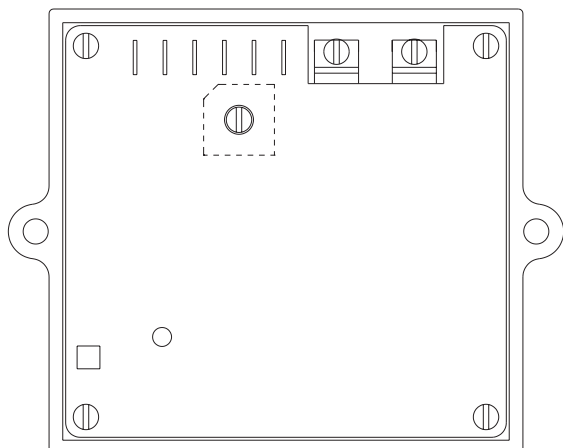

NOTE:

The voltage regulator is housed inside the generator's control panel. The regulator maintains a voltage in direct proportion to frequency at a 2-to-1 ratio. For example, at 62 Hertz, line-to-neutral voltage will be 124 volts.

3.1 BREAK-IN PROCEDURE

Once the unit has been installed and all electrical checks have been made, it is strongly recommended that the following "Break-in Procedure" be completed to ensure correct generator operation in the future.

1. Set the generator's AUTO/OFF/MANUAL switch to AUTO.
2. Turn OFF the utility power supply to the transfer switch using the means provided (such as a utility main line circuit breaker).
3. The unit will start, and the transfer switch will transfer to standby.

4. Run the unit for one hour at 25% rated load.
5. Run the unit for one hour at 50% rated load.
6. Run the unit for one hour at 75% rated load.
7. Run the unit for one hour at 100% rated load.
8. Turn ON the utility power supply to the transfer switch, which will allow the transfer switch to transfer back to utility power. The unit will continue to run for one minute and then shut down.
9. Allow the unit to cool.
10. Set the generator's AUTO/OFF/MANUAL switch to OFF. Remove the 7.5A and 15A fuses from the generator control panel. Disconnect the battery cables as outlined in "General Hazards" (page 2).
11. Drain the oil and remove the oil filter. Replace the oil filter according to Section 4.4, "Changing the Oil Filter". Replace the oil with synthetic oil as recommended in Section 4.3, "Changing the Engine Oil".
12. Reconnect the battery cables as outlined in "General Hazards" (page 2) and insert the 5A and 15A fuses into the generator control panel. The generator is now ready for service.

3.2 USING THE AUTO/OFF/MANUAL SWITCH (FIGURE 3.1)

◆ 3.2.1 "AUTO" POSITION

Selecting this switch position activates fully automatic system operation. It also allows personnel to start and exercise the engine every seven days with the setting of the exercise timer (see Section 3.5).

Figure 3.1 – Generator Control Panel

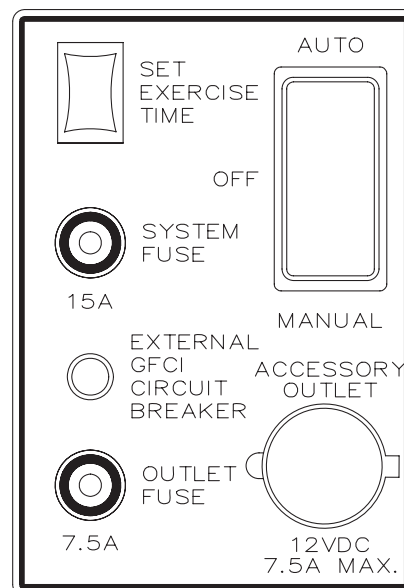

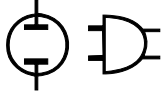

◆ 3.2.2 “OFF” POSITION

This switch position shuts down the engine. This position also prevents automatic operation.

◆ 3.2.3 “MANUAL” POSITION

Set the switch to Manual to crank and start the engine. Transfer to standby power will not occur unless there is a utility failure.

—▲ WARNING ▲—

▲ With the switch set to AUTO, the engine may crank and start at any time without warning. Such automatic starting normally occurs when utility power source voltage drops below a preset level or during the normal exercise cycle. To prevent possible injury that might be caused by such sudden starts, always set the switch to OFF and remove the fuses before working on or around the generator or transfer switch. Then, place a “DO NOT OPERATE” tag on the generator panel and on the transfer switch.

3.3 AUTOMATIC TRANSFER OPERATION

To select automatic operation, do the following:

1. Make sure the transfer switch main contacts are set to their “Utility” position, i.e., loads connected to the utility power source (Figure 3.2).
2. Be sure that normal utility power source voltage is available to transfer switch terminal lugs N1 and N2.
3. Set the generator’s AUTO/OFF/MANUAL switch to AUTO.
4. Set the generator’s main circuit breaker to its ON (or closed) position.

With the preceding steps complete, the generator will start automatically when utility source voltage drops below a preset level. After the unit starts, loads are transferred to the standby power source. Refer to Section 3.4, “Sequence of Automatic Operation.”

3.4 SEQUENCE OF AUTOMATIC OPERATION

The generator’s control panel houses a control logic circuit board. This board constantly monitors utility power source voltage. Should that voltage drop below a preset level, circuit board action will signal the engine to crank and start. After the engine starts, the circuit board signals the transfer switch to activate and connect load circuits to the standby power supply (load terminal lugs T1/T2 connect to terminal lugs E1/E2).

Upon restoration of utility source voltage above a preset level, generator circuit board action signals the transfer switch to transfer loads back to that power supply. After retransfer, the engine is signalled to shut down.

The actual sequence of operation is controlled by sensors and timers on a control logic circuit board, as follows:

- A. Utility Voltage Dropout Sensor
 - This sensor monitors utility source voltage.
 - If utility source voltage drops below about 70 percent of the nominal supply voltage, the sensor energizes a 15-second timer.
 - Once the timer has expired, the engine will crank and start.
- B. Engine Warm-up Time Delay
 - This mechanism lets the engine warm up for about 10 seconds before the load is transferred to the standby source.
- C. Utility Voltage Pickup Sensor
 - This sensor monitors utility power supply voltage. When that voltage is restored above 70 percent of the nominal source voltage, a retransfer time delay starts timing.
- D. Retransfer Time Delay
 - This timer runs for about 15 seconds.
 - At end of a 15-second delay, circuit board action de-energizes transfer relay in the transfer switch.
 - Retransfer to utility power source then occurs.
- E. Engine Cool-down Timer
 - When the load is transferred back to utility power source, the engine cool-down timer starts timing.
 - The timer will run for about one minute, and the generator will then shut down.

3.5 SETTING THE EXERCISE TIMER

This generator is equipped with an exercise timer. Once it is set, the generator will start and exercise once every seven days, on the day of the week and at the time of day the following sequence is completed. During this exercise period, the unit runs for approximately 12 minutes and then shuts down. Transfer of loads to the generator output does not occur during the exercise cycle.

A switch on the control panel (see Figure 3.1) permits selection of the day and time for the system to exercise. At the chosen time, perform the following sequence to select the desired day and time of day the system will exercise.

Place the AUTO/OFF/MANUAL switch in the AUTO position. Push and hold the “Set Exercise Time” switch to the ON position for approximately three seconds and release. All five red LED’s will flash for 10 seconds. The unit will perform the standard exercise sequence, then shut down. The generator will now exercise every seven days at the time set.

NOTE:

The exerciser will only work in the AUTO mode and will not work unless this procedure is performed. The exerciser will need to be reset every time the 12-volt battery is disconnected and then reconnected.

3.6 PROTECTION SYSTEMS

◆ 3.6.1 LOW OIL PRESSURE SWITCH

This switch (Figure 3.2) has normally closed contacts that are held open by engine oil pressure during cranking and operating. Should oil pressure drop below the 8 psi range, switch contacts close, and the engine shuts down. The unit should not be restarted until oil is added. The AUTO/OFF/MANUAL switch must then be turned to OFF and then back to AUTO.

◆ 3.6.2 HIGH TEMPERATURE SWITCH

This switch’s contacts (Figure 3.3) close if the temperature should exceed approximately 132° C (270° F), initiating an engine shutdown. The generator will automatically restart and the LED on the generator control panel will reset once the temperature has returned to a safe operating level.

Figure 3.2 – Low Oil Pressure and High Temperature Switches

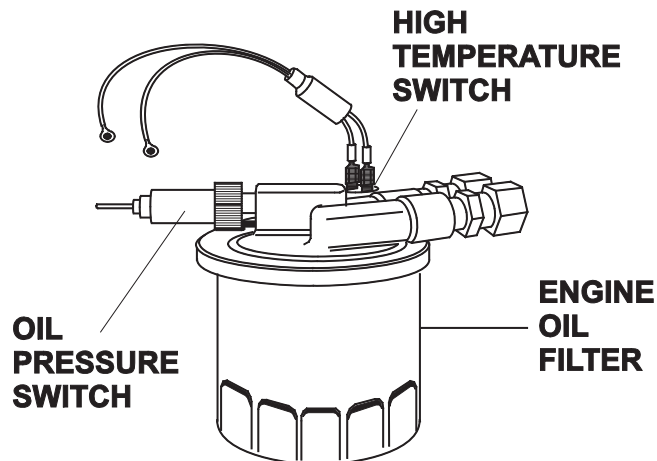

◆ 3.6.3 OVERCRANK

This feature prevents the generator from damaging itself when it continually attempts to start and another problem, such as no fuel supply, prevents it from starting. The unit will crank and rest for a preset time limit. Then, it will stop cranking, and the LED on the generator control panel will light indicating an overcrank failure. The AUTO/OFF/MANUAL switch will need to be set to OFF and then back to AUTO to reset the generator control board.

NOTE:

If the fault is not repaired, the overcrank feature will continue to activate.

3.6.3.1 Approximate Crank Cycle Times

- 15 seconds ON
 - 7 seconds OFF
 - 7 seconds ON
 - 7 seconds OFF
 - Repeat for 45 seconds
- Approximately 90 seconds total

◆ 3.6.4 OVERSPEED

This feature protects the generator from damage by shutting it down if it happens to run faster than the preset limit. This protection also prevents the generator from supplying an output that could potentially damage appliances connected to the generator circuit. Contact the nearest Authorized Dealer if this failure occurs.

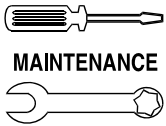

◆ 3.6.5 LOW BATTERY

The microprocessor will continually monitor the battery voltage and turn on the Low Battery LED if the battery voltage falls below 11.0 volts for one minute. Low battery voltage is a non-latching alarm, which will automatically clear if the battery voltage rises above 11.0 volts.

The control system will not attempt to start the engine if there is a low battery condition, however, if the engine is already running when the low battery condition occurs, the engine will continue to run as long as possible.

Battery voltage is NOT monitored during the crank cycle.

4.1 SYSTEM FUSE

The generator panel's 15 amp fuse (Figure 4.1) protects the DC control circuit against overload. The fuse is wired in series with the battery output lead to the panel. If the fuse element has melted open, the engine cannot crank or start. Replace the fuse using only an identical 15-amp replacement.

◆ 4.1.1 7.5 AMP FUSE

The generator panel's 7.5 amp fuse protects the accessory outlet against overload. If the fuse element has melted open, there will not be power at the accessory outlet. Replace the fuse using only an identical 7.5 amp fuse. To remove fuse, push cap down and rotate counterclockwise.

Figure 4.1 – Generator Control Panel

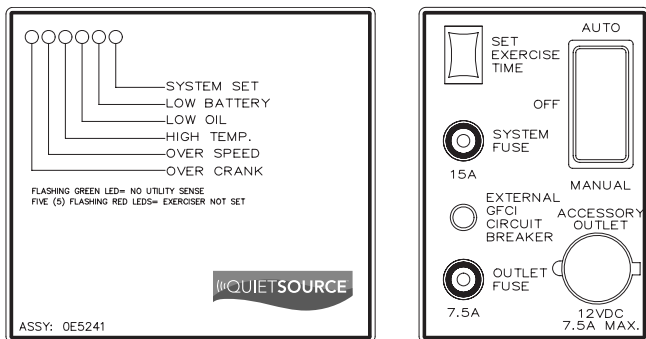

4.2 CHECKING THE ENGINE OIL LEVEL

For oil capacities, see “Specifications,” Section 1.5. For engine oil recommendations, see Section 4.3.1. To check the engine oil level, proceed as follows (Figures 4.2):

1. Start the generator by moving the AUTO/ OFF/ MANUAL switch to the MANUAL position. Allow it to run for a short while and then shut it down by moving the switch to the OFF position.
2. Remove the dipstick and wipe it dry with a clean cloth.
3. Install the dipstick; then, remove it again. The oil level should be at the dipstick “Full” mark. If necessary, add oil to the “Full” mark only. **DO NOT FILL ABOVE THE “FULL” MARK.**



⚠ Never operate the engine with the oil level below the “Add” mark on the dipstick. Doing this could damage the engine.

4. Install the dipstick.
5. Reset the AUTO/OFF/MANUAL switch to its original position.

Figure 4.2 — Oil Dipstick and Fill

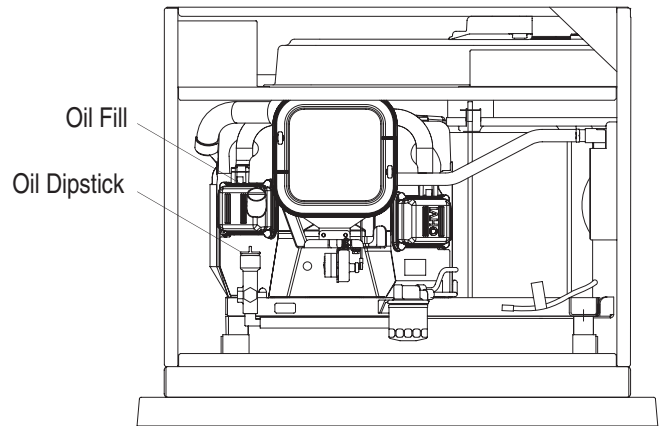

4.3 CHANGING THE ENGINE OIL

◆ 4.3.1 ENGINE OIL RECOMMENDATIONS

Use oil of American Petroleum Institute (API) Service Class SG, SH or SJ. Use all season SAE 5W-30 Synthetic oil. Organic break-in oil is required before using synthetic oil.

NOTE:

The unit is supplied with “break-in” oil. See the “Break-in Procedure,” Section 3.1, for the first required oil change.



—▲ CAUTION ▲—

▲ Any attempt to crank or start the engine before it has been properly serviced with the recommended oil may result in an engine failure.

◆ 4.3.2 OIL CHANGE PROCEDURE

To change the oil, proceed as follows:

1. Run the engine until it is thoroughly warmed up then shut OFF the engine.
2. Immediately after the engine shuts OFF, pull the oil drain hose (Figure 4.3) free of its retaining clip. Remove the cap from the hose and drain the oil into a suitable container.
3. After the oil has drained, replace the cap onto the end of the oil drain hose. Retain the hose in the clip.
4. Refill with the proper recommended oil (see Section 4.3.1). See Section 1.6.2 for oil capacities.

Figure 4.3 – Oil Drain Hose and Filter

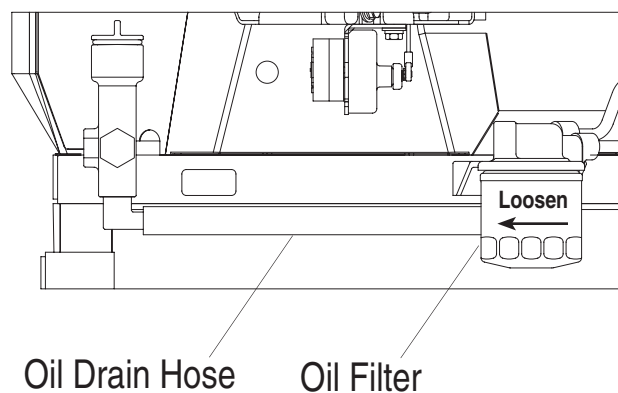

4.4 CHANGING THE OIL FILTER

Change the engine oil filter as follows:

1. With the oil drained, remove the old oil filter by turning it counterclockwise.
2. Apply a light coating of clean engine oil to the gasket of the new filter. See Section 1.6.1 for recommended filter.
3. Screw the new filter on by hand until its gasket lightly contacts the oil filter adapter. Then, tighten the filter an additional 3/4 to one turn (Figure 4.3).
4. Refill with the proper recommended oil (see Section 4.3.1). See Section 1.6.2 for oil capacities.
5. Start the engine and check for leaks.

4.5 CHANGING THE ENGINE AIR CLEANER

See Figure 1.3, for the location of the air cleaner. Use the following procedure (Figure 4.4):

1. Turn the two screws counterclockwise to loosen.
2. Remove the cover and air filter.
3. Wipe away dust or debris from inside of the air box and around edges.
4. Install the new air cleaner into the air box.
5. Install the cover. Turn the two cover screws clockwise to tighten.

See the “Service Schedule,” Section 4.13, for air cleaner maintenance. See Section 1.6.1 for air filter replacement part number.

Figure 4.4 — Engine Air Cleaner

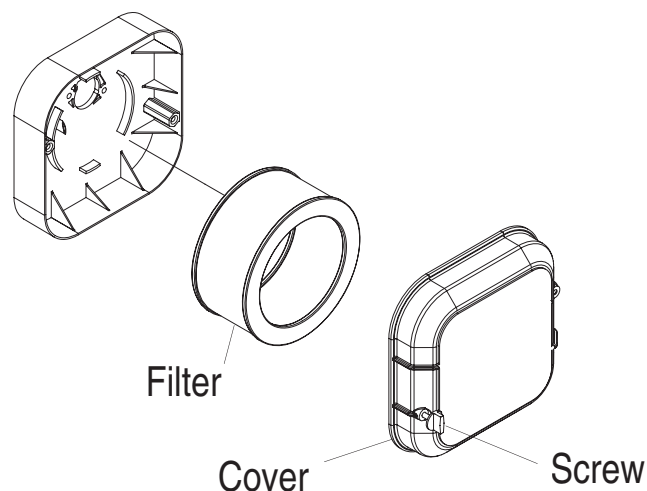

4.6 SPARK PLUGS

Reset the spark plug gaps or replace the spark plugs as necessary. See Section 4.13 for maintenance requirements.

1. Clean the area around the base of the spark plugs to keep dirt and debris out of the engine. Clean by scraping or washing using a wire brush and commercial solvent. Do not blast the spark plugs to clean.
2. Remove the spark plugs and check the condition. Replace the spark plugs if worn or if reuse is questionable. See Section 4.13 for recommended inspection.
3. Check the spark plug gap using a wire feeler gauge. Adjust the gap to 0.76 mm (0.030 inch) by carefully bending the ground electrode (Figure 4.5).

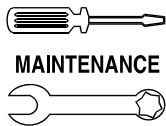

MAINTENANCE

Section 4 – Maintenance

Air-cooled 11 kW Generators

Figure 4.5 – Setting the Spark Plug Gap

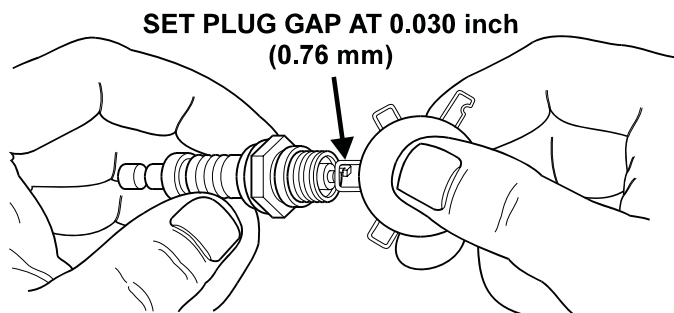

4.7 BATTERY MAINTENANCE

The battery should be inspected per the “Service Schedule,” Section 4.13. The following procedure should be followed for inspection:

1. Inspect the battery posts and cables for tightness and corrosion. Tighten and clean as necessary.
2. Check the battery fluid level of unsealed batteries and, if necessary, fill with Distilled Water Only. Do not use tap water in batteries.
3. Have the state of charge and condition checked. This should be done with an automotive-type battery hydrometer.

⚠ DANGER ⚠

⚠ Do not dispose of the battery in a fire. The battery is capable of exploding.

⚠ A battery presents a risk of electrical shock and high short circuit current. The following precautions are to be observed when working on batteries:

- Remove the 7.5A and 15A fuses from the generator control panel.
- Remove watches, rings or other metal objects;
- Use tools with insulated handles;
- Wear rubber gloves and boots;
- Do not lay tools or metal parts on top of the battery; and
- Disconnect charging source prior to connecting or disconnecting battery terminals.

⚠ WARNING ⚠

⚠ Do not open or mutilate the battery. Released electrolyte has been known to be harmful to the skin and eyes, and to be toxic.

⚠ The electrolyte is a dilute sulfuric acid that is harmful to the skin and eyes. It is electrically conductive and corrosive. The following procedures are to be observed:

- Wear full eye protection and protective clothing;
- Where electrolyte contacts the skin, wash it off immediately with water;

- Where electrolyte contacts the eyes, flush thoroughly and immediately with water and seek medical attention; and
- Spilled electrolyte is to be washed down with an acid neutralizing agent. A common practice is to use a solution of 1 pound (500 grams) bicarbonate of soda to 1 gallon (4 liters) of water. The bicarbonate of soda solution is to be added until the evidence of reaction (foaming) has ceased. The resulting liquid is to be flushed with water and the area dried.

⚠ Lead-acid batteries present a risk of fire because they generate hydrogen gas. The following procedures are to be followed:

- DO NOT SMOKE when near the battery;
- DO NOT cause flame or spark in battery area; and
- Discharge static electricity from body before touching the battery by first touching a grounded metal surface.

⚠ Be sure the AUTO/OFF/MANUAL switch is set to the OFF position before connecting the battery cables. If the switch is set to AUTO or MANUAL, the generator can crank and start as soon as the battery cables are connected.

⚠ Be sure the utility power supply is turned off and the 5A and 15A fuses are removed from the generator control panel, or sparking may occur at the battery posts as the cables are attached and cause an explosion.

4.8 ADJUSTING GT-990 VALVE CLEARANCE

After the first six months of operation, adjust the valve clearance in the engine (Figure 4.6).

Important: If feeling uncomfortable about doing this procedure or the proper tools are not available, please contact the Authorized Dealer for service assistance. This is a very important step to insure longest life for the engine.

To adjust valve clearance:

- Make sure the engine is at room temperature (between 60° and 80° F).
- Make sure that the spark plug(s) are removed.
- Remove the four screws attaching the valve cover with a #2 or #3 phillips screwdriver.
- Make sure the piston is at Top Dead Center (TDC) of its compression stroke (both valves closed). To get the piston at TDC, remove the screen at the top of the intake scroll to gain access to the intake fan. Rotate the engine by hand by rotating the fan while watching the piston through the spark plug hole. The piston should move back and forth. The piston is at TDC when it is as forward as it can go.

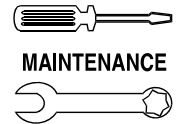

- Loosen the rocker jam nut. Use an 10mm allen wrench to turn the pivot ball stud while checking clearance between the rocker arm and the valve stem with a feeler gauge. Correct clearance is 0.002-0.004 inch (0.05-0.1 mm).

NOTE:

Hold the rocker arm jam nut in place as the pivot ball stud is turned.

When valve clearance is correct, hold the pivot ball stud in place with the allen wrench and tighten the rocker arm jam nut. Tighten the jam nut to 174 in.lbs. torque. After tightening the jam nut, recheck valve clearance to make sure it did not change.

Figure 4.6 - Valve Clearance Adjustment

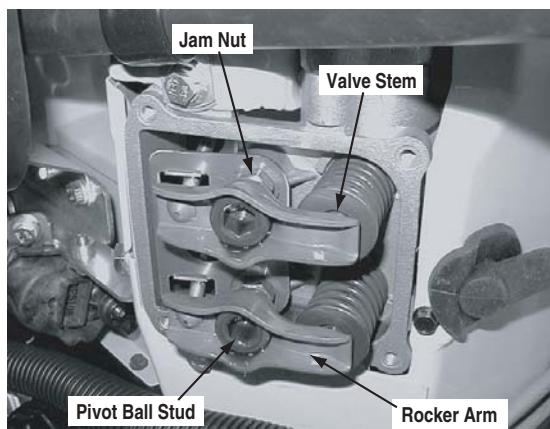

- Install new valve cover gasket.
- Re-attach the valve cover.

NOTE:

Start all four screws before tightening or it will not be possible to get all the screws in place. Make sure the valve cover gasket is in place.

- Re-attach the spark plug wire to the spark plug.
- Repeat the process for the other cylinder.

4.9 COOLING SYSTEM

Air inlet and outlet openings in the generator compartment must be open and unobstructed for continued proper operation. This includes such obstructions as high grass, weeds, brush, leaves and snow.

Without sufficient cooling and ventilating air flow, the engine/generator quickly overheats, which causes it to quickly shut down. (See Figure 4.7 for vent locations.)

WARNING

The exhaust from this product gets extremely hot and remains hot after shutdown. High grass, weeds, brush, leaves, etc. must remain clear of the exhaust. Such materials may ignite and burn from the heat of the exhaust system.

Figure 4.7 – Cooling Vent Locations

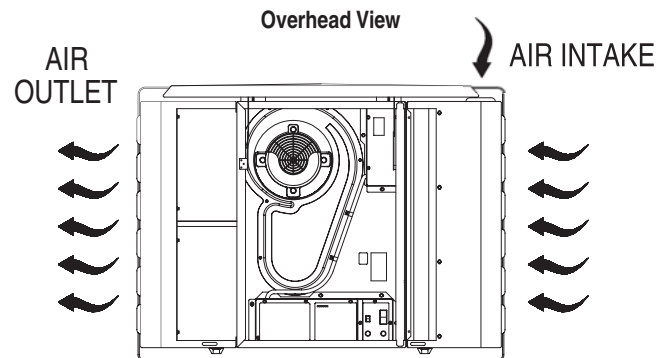

CAUTION

The maximum ambient temperature for the generator is 40° C (104° F).

4.10 ATTENTION AFTER SUBMERSION

If the generator has been submerged in water, it **MUST NOT** be started and operated. Following any submersion in water, have an Authorized Dealer thoroughly clean and dry the generator.

4.11 CORROSION PROTECTION

Periodically wash and wax the enclosure using automotive type products. Frequent washing is recommended in salt water/coastal areas. Spray engine linkages with a light oil such as WD-40®.

4.12 OUT OF SERVICE PROCEDURE

4.12.1 REMOVAL FROM SERVICE

If the generator cannot be exercised every seven days, and will be out of service longer than 90 days, prepare the generator for storage as follows:

- Start the engine and let it warm up.
- Close the fuel shutoff valve in the fuel supply line and allow the unit to shut down.
- Once the unit has shut down, it will signal a low oil fault.
- Set the AUTO/OFF/MANUAL switch to OFF and turn off the utility power to the transfer switch. Remove the 7.5A and 15A fuses from the generator control panel. Disconnect the battery cables as outlined in "General Hazards" (page 2).
- While the engine is still warm from running, drain the oil completely. Refill the crankcase with oil. See "Engine Oil Recommendations," Section 4.3.1.
- Attach a tag to the engine indicating the viscosity and classification of the oil in the crankcase.

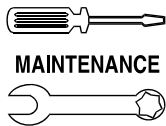

MAINTENANCE

Section 4 – Maintenance

Air-cooled 11 kW Generators

7. Remove the spark plug(s) and spray fogging agent into the spark plug(s) threaded openings. Reinstall and tighten the spark plug(s).
8. Remove the battery and store it in a cool, dry room on a wooden board. Never store the battery on any concrete or earthen floor.
9. Clean and wipe the entire generator.

◆ 4.12.2 RETURN TO SERVICE

To return the unit to service after storage, proceed as follows:

1. Verify that utility power is turned off and that the AUTO/OFF/MANUAL switch is set to OFF.
2. Check the tag on the engine for oil viscosity and classification. Verify that the correct recommended oil is used in the engine (see Section 4.3.1). If necessary, drain and refill with the proper oil.
3. Check the state of the battery. Fill all cells of unsealed batteries to the proper level with distilled water. **DO NOT USE TAP WATER IN THE BATTERY.** Recharge the battery to 100 percent state of charge, or, if defective, replace the battery. See “Specifications,” Section 1.6, for type and size.

4. Clean and wipe the entire generator.
5. Remove the 7.5A and 15A fuses from the generator control panel. Reconnect the battery. Observe battery polarity. Damage may occur if the battery is connected incorrectly.
6. Open the fuel shutoff valve.
7. Insert the 7.5A and 15A fuses into the generator control panel. Start the unit by moving the AUTO/OFF/MANUAL switch to MANUAL. Allow the unit to warm up thoroughly.
8. Stop the unit by setting the AUTO/OFF/MANUAL switch to OFF.
9. Turn on the utility power to the transfer switch.
10. Set the AUTO/OFF/MANUAL switch to AUTO.
11. The generator is now ready for service.

NOTE:

If the battery was dead or disconnected, the exercise timer must be reset.

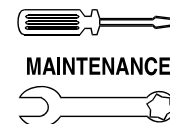

4.13 SERVICE SCHEDULE

ATTENTION: It is recommended that all service work be performed by the nearest Authorized Dealer.

SYSTEM/COMPONENT	PROCEDURE			FREQUENCY
	Inspect	Change	Clean	
X = Action R = Replace as Necessary * = Notify Dealer if Repair is Needed.				W = Weekly M = Monthly Y = Yearly
FUEL				
Fuel lines and connections*	X			M
LUBRICATION				
Oil level	X			M
Oil		X		AFTER BREAK-IN, AND Y
Oil filter		X		AFTER BREAK-IN, AND Y
COOLING				
Enclosure louvers	X		X	W
BATTERY				
Remove corrosion, ensure dryness	X		X	M
Clean and tighten battery terminals	X		X	M
Check charge state	X	R		EVERY 6 M
Electrolyte level (unsealed batteries only)*	X	R		EVERY 6 M
ENGINE AND MOUNTING				
Air cleaner	X	R		Y
Spark plug(s)	X	R		Y
GENERAL CONDITION				
Vibration, Noise, Leakage, Temperature*	X			M
COMPLETE TUNE-UP*	TO BE COMPLETED BY A GENERAC AUTHORIZED DEALER			Y



5.1 TROUBLESHOOTING GUIDE

Problem	Cause	Correction
The engine will not crank.	<ol style="list-style-type: none"> 1. Fuse blown. 2. Loose, corroded or defective battery cables. 3. Defective starter motor. 4. Dead Battery. 	<ol style="list-style-type: none"> 1. Replace 15A fuse in generator control panel. 2. Tighten, clean or replace as necessary. 3. * 4. Charge or replace battery.
The engine cranks but will not start.	<ol style="list-style-type: none"> 1. Out of fuel. 2. Defective fuel solenoid (FS). 3. Open #14 wire from engine control board. 4. Defective spark plug(s). 5. Valve lash out of adjustment. 	<ol style="list-style-type: none"> 1. Replenish fuel. 2. * 3. * 4. Clean, re-gap or replace plug(s). 5. Reset valve lash.
The engine starts hard and runs rough.	<ol style="list-style-type: none"> 1. Air cleaner plugged or damaged. 2. Defective spark plug(s). 3. Fuel Pressure incorrect. 	<ol style="list-style-type: none"> 1. Check, replace air cleaner. 2. Clean, re-gap or replace plug(s). 3. Confirm fuel pressure to regulator is 5-7" water column (0.18 to 0.25) for natural gas; 10-12" water column (0.36 to 0.43 psi) for liquid propane vapor.
The AUTO/OFF/MANUAL switch is set to OFF, but the engine continues to run.	<ol style="list-style-type: none"> 1. Defective switch. 2. AUTO/OFF/MANUAL switch wired incorrectly. 3. Defective control board. 	<ol style="list-style-type: none"> 1. * 2. * 3. *
There is no AC output from the generator.	<ol style="list-style-type: none"> 1. Main line circuit breaker open. 2. Generator internal failure. 	<ol style="list-style-type: none"> 1. Reset circuit breaker to ON (or closed). 2. *
There is no transfer to standby after utility source failure.	<ol style="list-style-type: none"> 1. Defective transfer switch coil. 2. Defective transfer relay. 3. Transfer relay circuit open. 4. Defective control logic board. 	<ol style="list-style-type: none"> 1. * 2. * 3. * 4. *
Unit consumes large amounts of oil.	<ol style="list-style-type: none"> 1. Break-in procedure not followed (see Section 2.1). 	<ol style="list-style-type: none"> 1. *

***Contact the nearest Authorized Dealer for assistance.**

Section 6 – Installation Diagram

Air-cooled 11 kW Generators

Installation Diagram – Drawing No. 0E7612-A

INSTALLATION

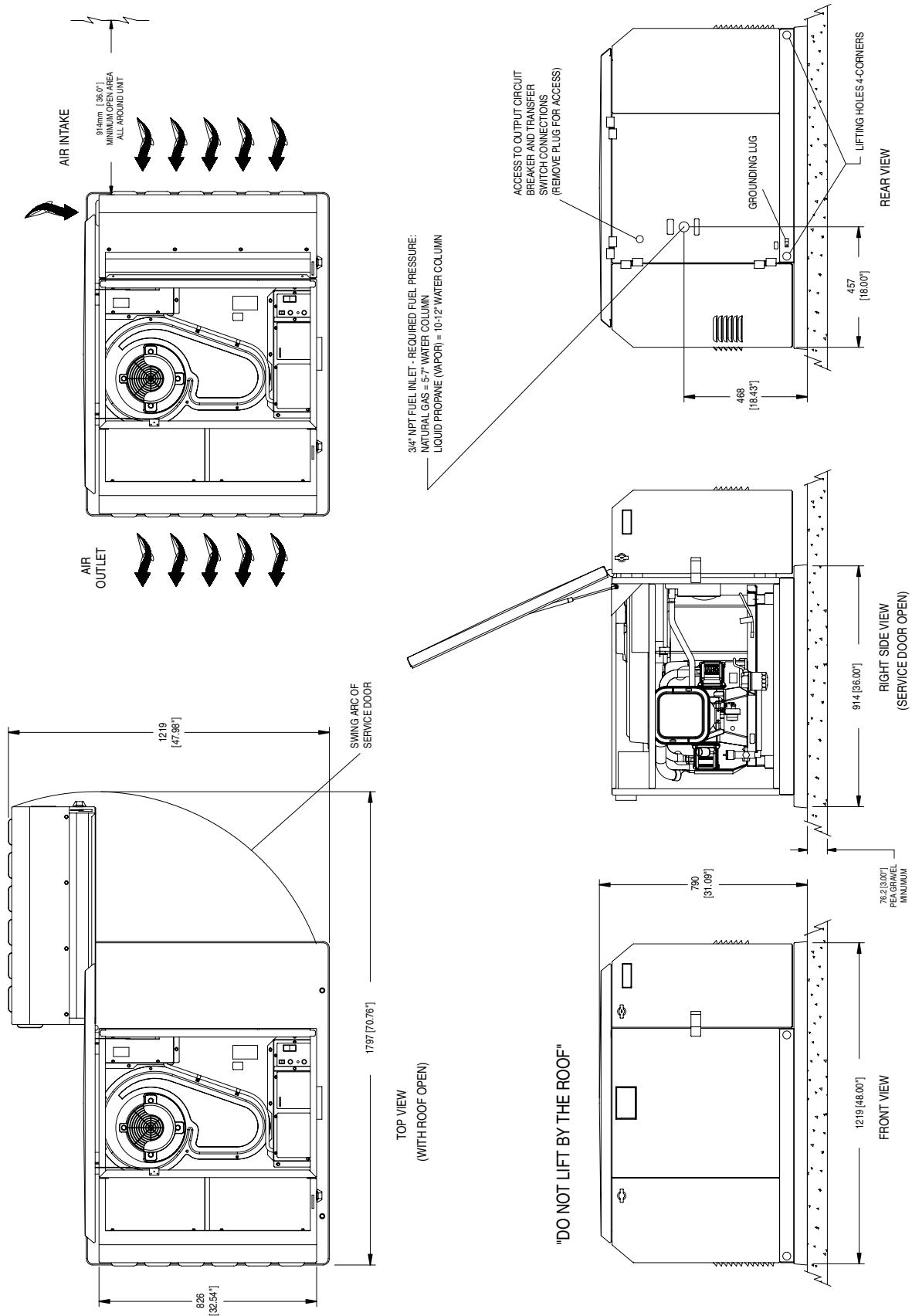
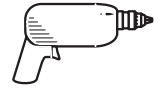

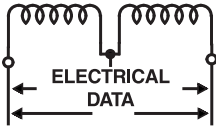

Section 7 – Electrical Data

Air-cooled 11 kW Generators

Wiring Diagram – Drawing No. 0E7071-B

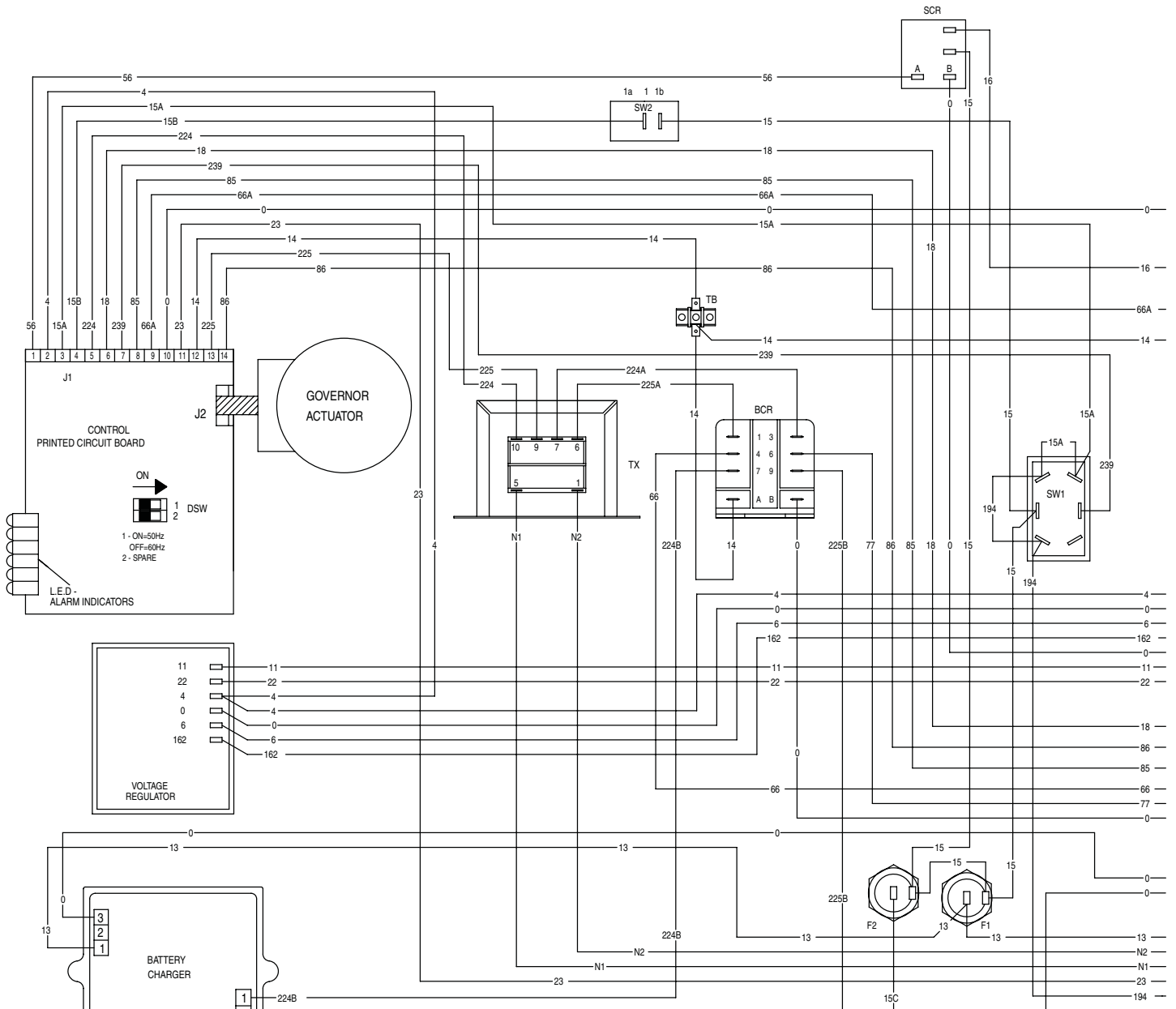

- DIAGRAM KEY
- BA - BRUSH ASSEMBLY
 - BCR - BATTERY CHARGE RELAY
 - C1 - 8 POS. DEUTSCH CONNECTOR
 - C2 - 12 POS. DEUTSCH CONNECTOR
 - CB1 - MAIN OUTPUT BREAKER
 - CB2 - CIRCUIT BREAKER, ALTERNATOR EXCITATION
 - CB3 - CIRCUIT BREAKER, EXTERNAL OUTLET, PUSH/PULL
 - D - DIODE
 - DSW - PCB MOUNTED DIP SWITCH
 - FS - FUEL SOLENOID
 - F1 - FUSE 15 AMP
 - F2 - FUSE 7.5 AMP
 - GRD 1 - CONTROL PANEL GROUND
 - GRD 2 - CONTROL PANEL GROUND, ISOLATED
 - HTO - HIGH OIL TEMPERATURE SWITCH
 - IC - INLINE CONNECTOR
 - IM1, IM2 - IGNITION MODULE, CYLINDER #1/#2
 - LOP - LOW OIL PRESSURE SWITCH
 - SC - STARTER CONTACTOR
 - SCR - STARTER CONTACTOR RELAY
 - SM - STARTER MOTOR
 - SW1 - SWITCH, AUTO / OFF / MANUAL
 - SW2 - SWITCH, SET EXERCISE
 - SP1, SP2 - SPARK PLUGS
 - TB - INSULATED TERMINAL BLOCK
 - TX - TRANSFORMER, 16 Vac 56 VA & 16 Vac 1 VA (DUAL SEC.)

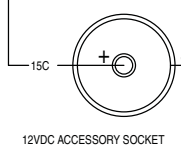

CONTROL PANEL BOX

Section 7 – Electrical Data
Air-cooled 11 kW Generators
Wiring Diagram – Drawing No. 0E7071-B

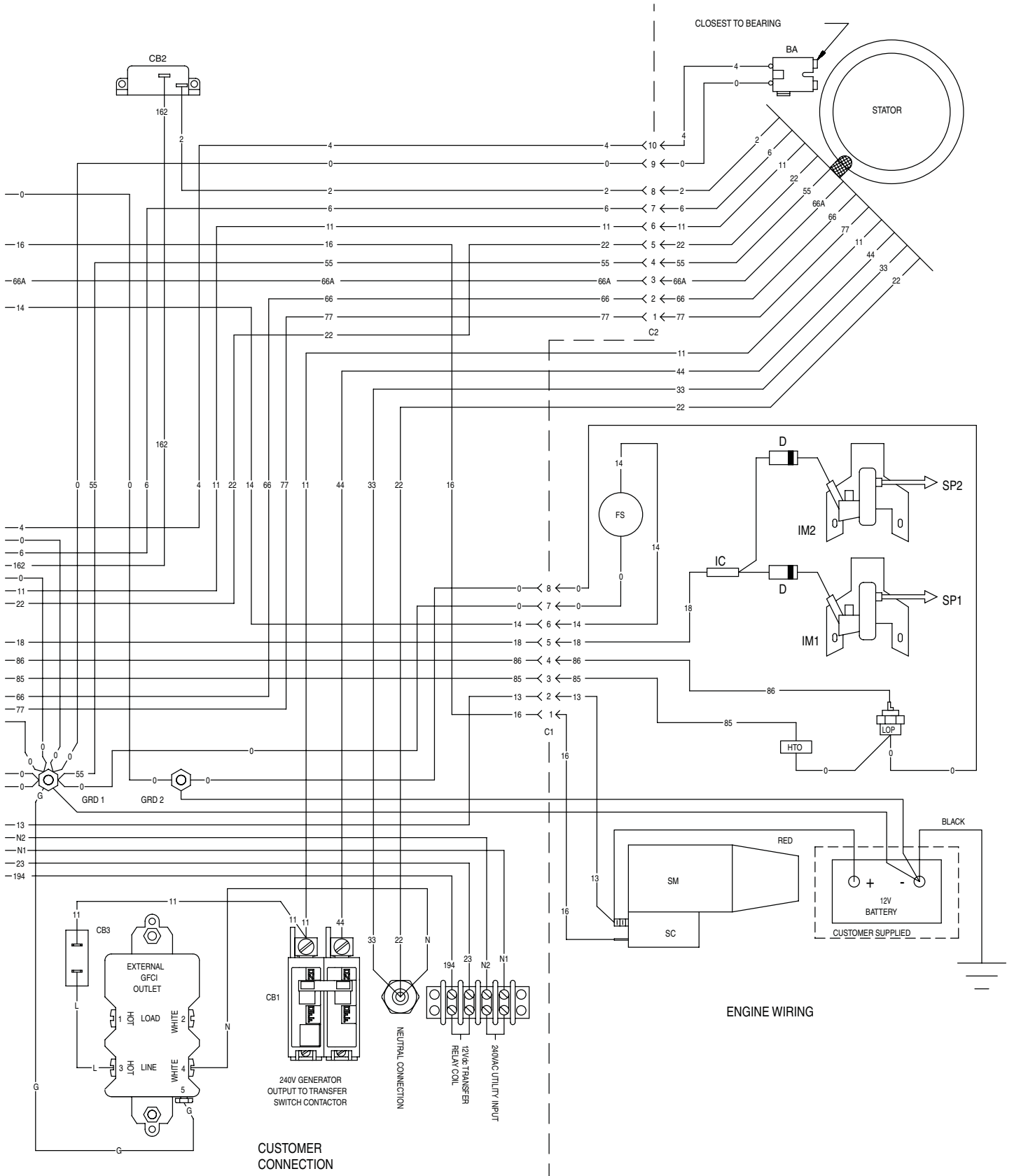
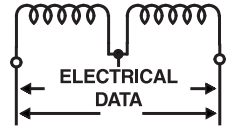

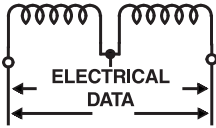

Section 7 – Electrical Data

**Air-cooled 11 kW Generators
Electrical Schematic – Drawing No. 0E7073-B**

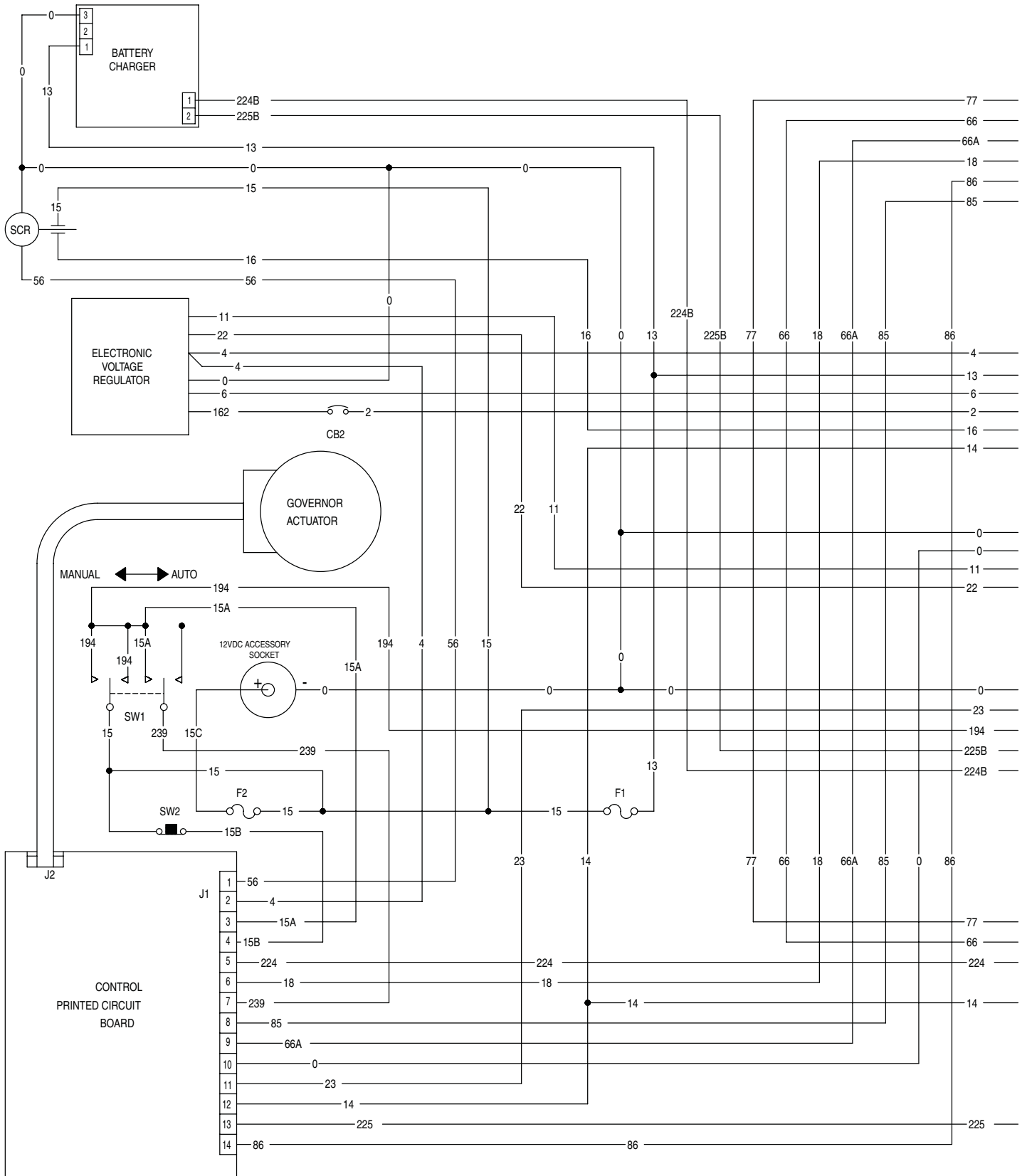

Section 7 – Electrical Data
Air-cooled 11 kW Generators
Electrical Schematic – Drawing No. 0E7073-B

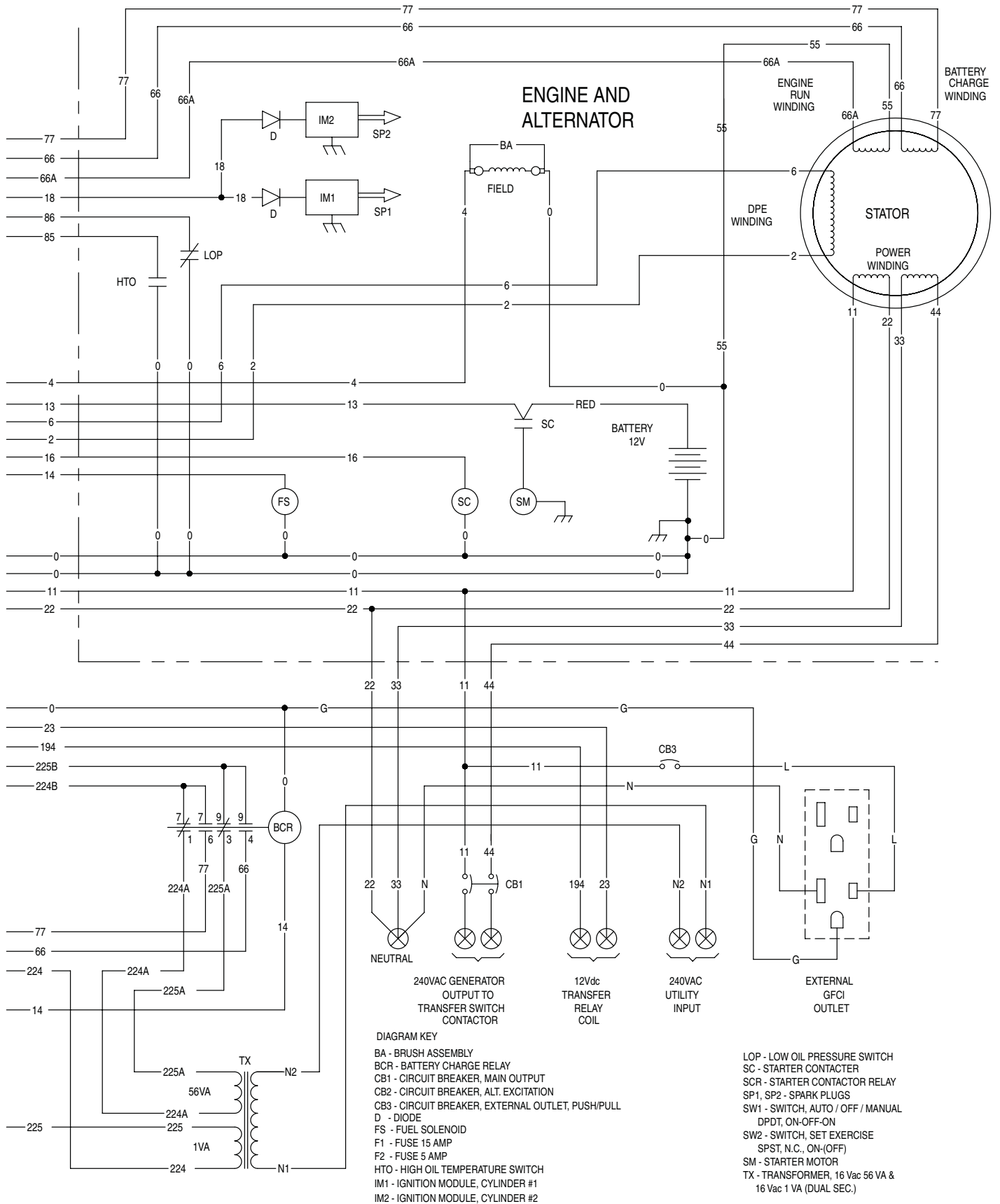
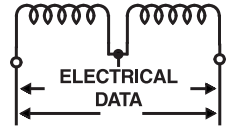

Section 8 – Exploded Views and Parts Lists

**Air-cooled 11 kW Generators
Enclosure – Drawing No. 0E4884-B**

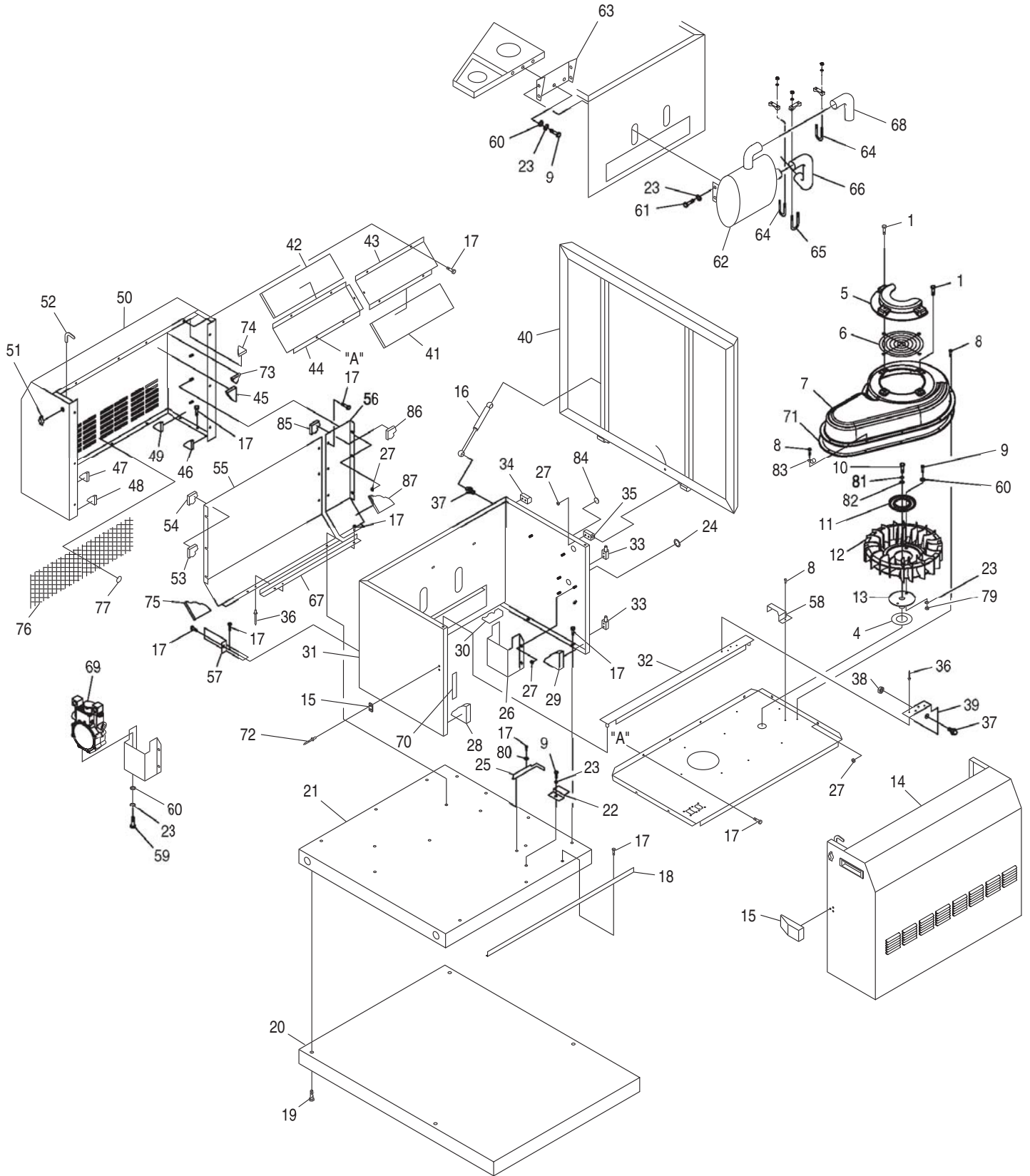

Section 8 – Exploded Views and Parts Lists

Air-cooled 11 kW Generators Enclosure – Drawing No. 0E4884-B

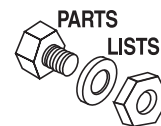

ITEM	PART NO.	QTY.	DESCRIPTION	ITEM	PART NO.	QTY.	DESCRIPTION
1	0E7325	4	HHFS, 1/4"-20 X 5/8" GRADE 5	46	0E5297A	1	FOAM, BACK PANEL THERMAL ACOUSTIC
4	0E6884	1	SEAL, ALTERNATOR SHAFT	47	0E5297D	1	FOAM, FRONT PANEL THERMAL ACOUSTIC
5	0E4706A	1	SOUND Baffle INTAKE SCROLL	48	0E5297B	1	FOAM, FRONT PANEL THERMAL ACOUSTIC
6	0D1131	1	GUARD,FAN	49	0E5297C	1	FOAM, BACK PANEL THERMAL ACOUSTIC
7	0E4706	1	SCROLL, INTAKE	50	0E4385	1	DUCT, EXHAUST
8	0C2824	11	SCREW TAP-R #10-32 X 9/16"	51	0D3037A	1	LATCH, 1/4 TURN NONLOCKING
9	039253	6	SCREW HHC M8-1.25 X 20	52	0C7781A	1	PAWL, DOOR
10	0A8250	1	SCREW HHC 3/8"-24 X 2" G8	53	0E5298C	1	FOAM, 646 X 447 THERMAL ACOUSTIC
11	0C3032	1	PLATE, FAN	54	0E5298D	1	FOAM, 610 X 452 THERMAL ACOUSTIC
12	0C3031	1	FAN FLYWHEEL NYLON	55	0E4813	1	BAFFLE FRONT EXHAUST DIVIDER
13	0E4683	1	FAN HUB WITH D-DRIVE	56	0E4384	1	BAFFLE BACK EXHAUST DIVIDER
14	0E4378	1	ASSEMBLY, AIR INTAKE DUCT	57	0E4783	1	DEFLECTOR, EXHAUST
15	0E6342	1	LATCH, ADJUSTABLE DRAW	58	0E6005	1	DEFLECTOR, ALTERNATOR AIR
16	0E7570	2	GAS SPRING	59	042907	2	SCREW HHC M8-1.25 X 16mm
17	0E2874	37	SCREW TAP-R 1/4"-20 X 3/4"	60	022145	7	WASHER FLAT 5/16"-M8
18	0E4808	1	SUPPORT LOWER AIR INTAKE SEAL	61	040976	4	SCREW SHC M8-1.25 X 20mm
19	083512	4	SCREW HHTT M8-1.2 X 16mm	62	0E5267	1	MUFFLER
20	0E4809A	1	BASE PAD	63	0E3156	1	BRACKET, MUFFLER
21	0E4377	1	BASE, ENCLOSURE	64	0D5823	2	BOLT U 5/16"-18 X 1.62" WITH SADDLE
22	0C2937	1	BRACKET BATTERY HOLD DOWN	65	025145	1	BOLT U 5/16"-18 X 1.25" WITH SADDLE
23	022129	12	WASHER LOCK M8-5/16"	66	0E3206	1	TUBE, MUFFLER INLET
24	0E1330A	1	GROMMET, 38.1mm CROSS SLIT WITH HOLE	67	0E7550	1	DEFLECTOR, EXHAUST
25	0E4805	1	BRACKET, BATTERY POSITION	68	0E5268	1	TAILPIPE, SS HSB EXHAUST
26	0E4811	1	BRACKET, REGULATOR	69	0D9166	1	ASSEMBLY, TWIN REGULATOR
27	0D3700	26	NUT FLANGE M6-1.0 NYLOK	70	0E5968	9.3'	GASKET, EXTRUDED TRIM
28	0E5299D	1	FOAM, ENGINE SIDE PANEL ACOUSTIC	71	0E6820	1	GASKET, SCROLL
29	0E5299C	1	FOAM, ALTERNATOR SIDE PANEL ACOUSTIC	72	087233	5	RIVET POP 0.187" X 0.450"
30	0E5297	1	FOAM, ENGINE ENCLOSURE BACK	73	0E5298A	1	FOAM, 746 X 92.5 THERMAL ACOUSTIC
31	0E4379	1	ENCLOSURE, POWER HEAD	74	0E5298B	1	FOAM, 746 X 42.5 THERMAL ACOUSTIC
32	0E5273	1	RAIL, ROOF STAY SUPPORT	75	0E5298G	1	FOAM, 646 X 86.8 THERMAL ACOUSTIC
33	0F0165	2	HINGE TYPE B WITH STUDS, PIN	76	0E2833D	1	SHEET, HARDWIRE CLOTH 787 X 267
34	0F0165A	1	HINGE TYPE B WITH STUDS, SOCKET	77	0D7176	14	WASHER SELF LOCKING
35	0F0164A	1	HINGE TYPE A WITH STUDS, SOCKET	79	045771	2	NUT HEX M8-1.25 G8
36	036261	6	RIVET POP 0.125" X 0.275"	80	0A1658	1	WASHER LOCK SPECIAL 1/4"
37	0E7571	2	BALL STUD, GAS SPRING MOUNT	81	022237	1	WASHER LOCK 3/8"
38	027028	2	NUT LOCK HEX 5/16-18 NYL INSRT	82	022131	1	WASHER FLAT 3/8"
39	0E7725	1	BRACKET, GAS SPRING	83	031791	2	CLAMP CABLE 0.48" X 0.204" PLASTIC
40	0E6513	1	ASSEMBLY, ROOF	84	025034	1	PLUG STEEL 1.06"
41	0E5298F	1	FOAM, 400 X 220 THERMAL ACOUSTIC	85	0E5298H	1	FOAM, 110 X 452 THERMAL ACOUSTIC
42	0E5298E	1	FOAM, 421.5 X 220 THERMAL ACOUSTIC	86	0E5298J	1	FOAM, 146 X 447 THERMAL ACOUSTIC
43	0E4380	1	COVER, BACK EXHAUST ENCLOSURE	87	0E5298K	1	FOAM, 146 X 86.8 THERMAL ACOUSTIC
44	0E4382	1	COVER, FRONT EXHAUST ENCLOSURE				
45	0E5298	1	FOAM, 746 X 296.5 THERMAL ACOUSTIC				

Section 8 – Exploded Views and Parts Lists

**Air-cooled 11 kW Generators
Control Panel – Drawing No. 0E4879-D**

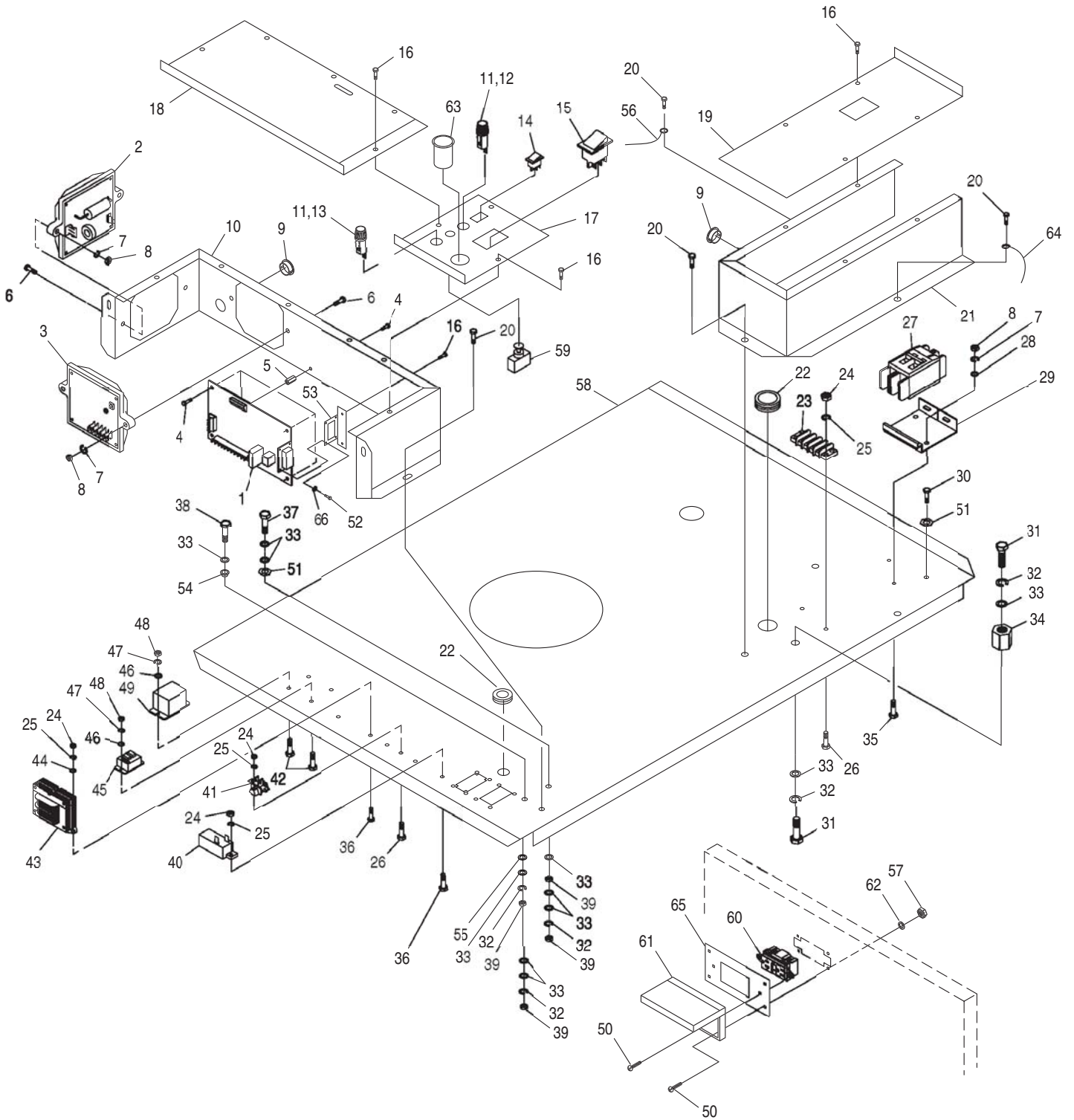

Section 8 – Exploded Views and Parts Lists

Air-cooled 11 kW Generators Control Panel – Drawing No. 0E4879-D

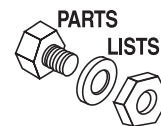

ITEM	PART NO.	QTY.	DESCRIPTION	ITEM	PART NO.	QTY.	DESCRIPTION
1	0E3312	1	ASSEMBLY, HOME STANDBY CONTROLLER	34	0D8502	1	NEUTRAL ISOLATOR
2	0A1801	1	ASSEMBLY, BATTERY CHARGER ENGINE	35	045770	2	SCREW HHC M5-0.8 X 10mm
3	083049	1	ASSEMBLY, POTTED REGULATOR	36	075475	4	SCREW PPHM M4-0.7 X 10mm
4	092036	8	PPHM S/LW #6-32 X 1/4" LONG	37	049721	1	SCREW HHC M6-1.0 X 35mm
5	0D3062A	4	HEX STAND-OFF #6-32 X 3/4"	38	038750	1	SCREW HHC M6-1.0 X 30mm
6	075235	4	SCREW HHC M5-0.8 X 30mm	39	049813	4	NUT HEX M6 X 1.0
7	049226	6	WASHER LOCK M5	40	054502	1	CIRCUIT BREAKER 3 X 1
8	051716	6	NUT HEX M5-0.8	41	075210A	1	BLOCK 1 POSITION
9	023484D	2	SNAP BUSHING 0.875"	42	0C1085	4	SCREW PPHM M3-0.5 X 8mm
10	0E4387	1	CONTROL, PANEL	43	0C3910	1	TRANSFORMER
11	032300	2	HOLDER FUSE	44	043180	2	WASHER FLAT M4
12	022676	1	FUSE, 15AMP X AGC15	45	0C2174	1	RELAY 12V 25A SPST
13	0A9611	1	FUSE, 7.5AMP X AGC7.5	46	031879	4	WASHER FLAT #4
14	0E3928	1	SWITCH, ROCKER SPST (ON)-OFF N/C	47	043182	4	WASHER LOCK M3
15	0E4494	1	SWITCH ROC DPDT ON-OFF-ON	48	051714	4	NUT HEX M3-0.5
16	074908	13	SCREW HHTT M5-0.8 X 10mm	49	063617	1	RELAY PANEL 12VDC DPDT 10A 240VAC
17	0E4806	1	COVER, CONTROL PANEL RIGHT	50	036903	6	SCREW PPHM #6-32 X 5/8"
18	0E5206	1	COVER, CONTROL PANEL LEFT	51	0A1658	2	WASHER LOCK SPECIAL 1/4"
19	0E6045	1	COVER, CONNECTION BOX	52	059636	4	PLASTITE PH #4 X 0.37"
20	045756	7	SCREW HHTT M6-1.0 X 10mm	53	0E5280	1	BRACKET, PCB HEADER SUPPORT
21	0E6044	1	CONNECTION BOX	54	0E6553	1	ISOLATOR/SHOULDER WASHER NYLON
22	096021	2	GROMMET 0.75" X 0.06" X 0.50"	55	0E6553A	1	WASHER NYLON 0.50" X 0.32" X 0.12"
23	046689	1	TERMINAL STRIP	56	0912970063	1	GROUND WIRE
24	051715	8	NUT HEX M4-0.7	57	082625	4	NUT LOCK HEX #6-32 NYL INSERT
25	022264	8	WASHER LOCK #8-M4	58	0E4381	1	PANEL, TOP COMPARTMENT
26	075476	4	SCREW PPHM M4-0.7 X 16mm	59	0E5840	1	CIRCUIT BREAKER 15A PUSH / PULL MAIN RESET
27	0E7886D	1	CIRCUIT BREAKER	60	0E4261	1	OUTLET, 15A GFCI DUPLEX
28	023897	2	WASHER FLAT #10	61	0E7833	1	PLATE, WEATHERPROOF GFCI
29	0E7890	1	CIRCUIT BREAKER MOUNTING BRACKET	62	022985	4	WASHER FLAT #6
30	083512	1	SCREW HHTT M8-1.2 X 16mm	63	0E9056	1	SOCKET, 12VDC ACCESSORY
31	022507	2	SCREW HHC 1/4"-20 X 1/2" LONG	64	0912970064	1	GROUND WIRE
32	022097	4	WASHER LOCK M6-1/4"	65	0E9171	1	GASKET, WEATHERPROOF GFCI
33	022473	10	WASHER FLAT 1/4"-M6	66	043182	4	WASHER LOCK M3

Section 8 – Exploded Views and Parts Lists

Air-cooled 11 kW Generators

GT-990 Engine – Drawing No. 0F2000

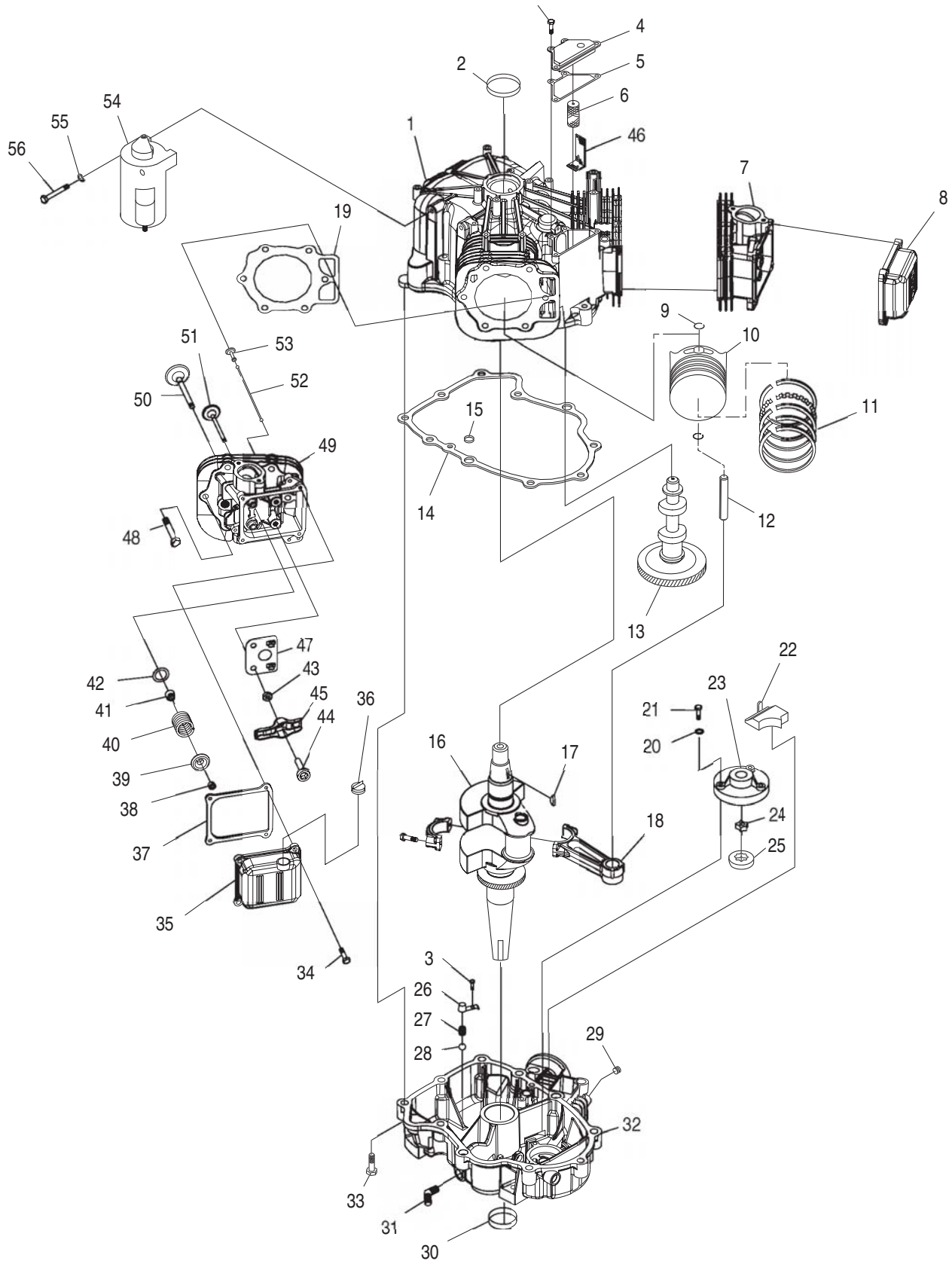

Section 8 – Exploded Views and Parts Lists

**Air-cooled 11 kW Generators
GT-990 Engine – Drawing No. 0F2000**

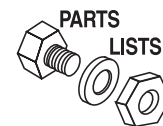

ITEM	PART NO.	QTY.	DESCRIPTION
1	0C5730A	1	ASSEMBLY, CRANKCASE RV
2	0E9843	1	SEAL, 38 I.D. CRANKCASE
3	090388	6	SCREW, HHTT M6-1.0 X 12mm
4	0C5372	1	ASSEMBLY, BREATHER
5	0C3005	1	GASKET, BREATHER COVER
6	0E3372A	1	SEPARATOR, OIL BREATHER
7	0D8067A	1	ASSEMBLY, HEAD #1
8	0C2981C	1	COVER, ROCKER
9	071983	4	RETAINER, PISTON PIN 20
10	0E2950	2	PISTON
11	021533	2	SET, PISTON RING 90mm
12	0E1466	2	PIN , PISTON
13	0D4041	1	ASSEMBLY, CAMSHAFT & GEAR
14	0C2977	1	GASKET, CRANK CASE
15	0C5943	1	SEAL, OIL PASSAGE
16	0E4357A	1	ASSEMBLY, CRANKSHAFT
17	082774	1	KEY, WOODRUFF 4 X 19D
18	0E3223	2	ASSEMBLY, CONNECTING ROD
19	0C2978	2	GASKET, HEAD
20	093873	3	WASHER, LOCK RIB M6
21	021374	3	SCREW, SHC M6-1.0 X 30mm
22	0C2994	1	SCREEN, OIL PICKUP
23	0C2997	1	COVER, GEROTOR
24	0C2995	1	GEROTOR, INNER
25	0C2996	1	GEROTOR, OUTER
26	0C3011	2	COVER, OIL RELIEF
27	0C3009	2	SPRING, OIL RELIEF
28	0C3010	2	BALL, 1/2D OIL RELIEF
29	050873A	1	1/4" NPT PIPE PLUG
30	0E9842	1	SEAL, 42 I.D. CRANKSHAFT
31	0D9756	1	CONNECTOR, 3/8NPT TO INVTD FLR 3/8OD
32	0C5732A	1	ASSEMBLY SUMP WITH PLUG
33	0C3006	10	SCREW, HHFC M10-1.5 X 55mm
34	080318	8	SCREW HHFC M6-1.0 X 25mm
35	0C2982	1	COVER, ROCKER WITH OIL FILL
36	093064	1	ASSEMBLY, OIL FILL CAP
37	0C2979	2	GASKET, VALVE COVER
38	086515	8	KEEPER, VALVE SPRING
39	0D2274	4	RETAINER, VALVE SPRING
40	0D3867	4	SPRING, VALVE
41	078672	2	SEAL, VALVE STEM D7
42	0C5371	4	WASHER, VALVE SPRING
43	0D3998	4	NUT HEX M8-1.0 G8
44	072694	4	STUD ROCKER ARM PIVOT
45	0D5313	4	ROCKER ARM
46	0E3273	1	SCREEN CRANKCASE BREATHER
47	0D6024	2	PLATE, PUSH ROD GUIDE
48	0C2976	12	SCREW HHFC M8-1.25 X 65mm
49	0D8067B	1	ASSEMBLY, HEAD #2
50	0C2229	2	VALVE, INTAKE
51	086516	2	VALVE, EXHAUST
52	0D9853D	4	PUSHROD 147
53	083897	4	TAPPET, SOLID
54	0E9323	1	STARTER MOTOR
55	022129	2	WASHER LOCK M8
56	061906	2	SCREW, HHC M8-1.25 X 85mm

Section 8 – Exploded Views and Parts Lists

**Air-cooled 11 kW Generators
Engine Accessories – Drawing No. 0F2001-D**

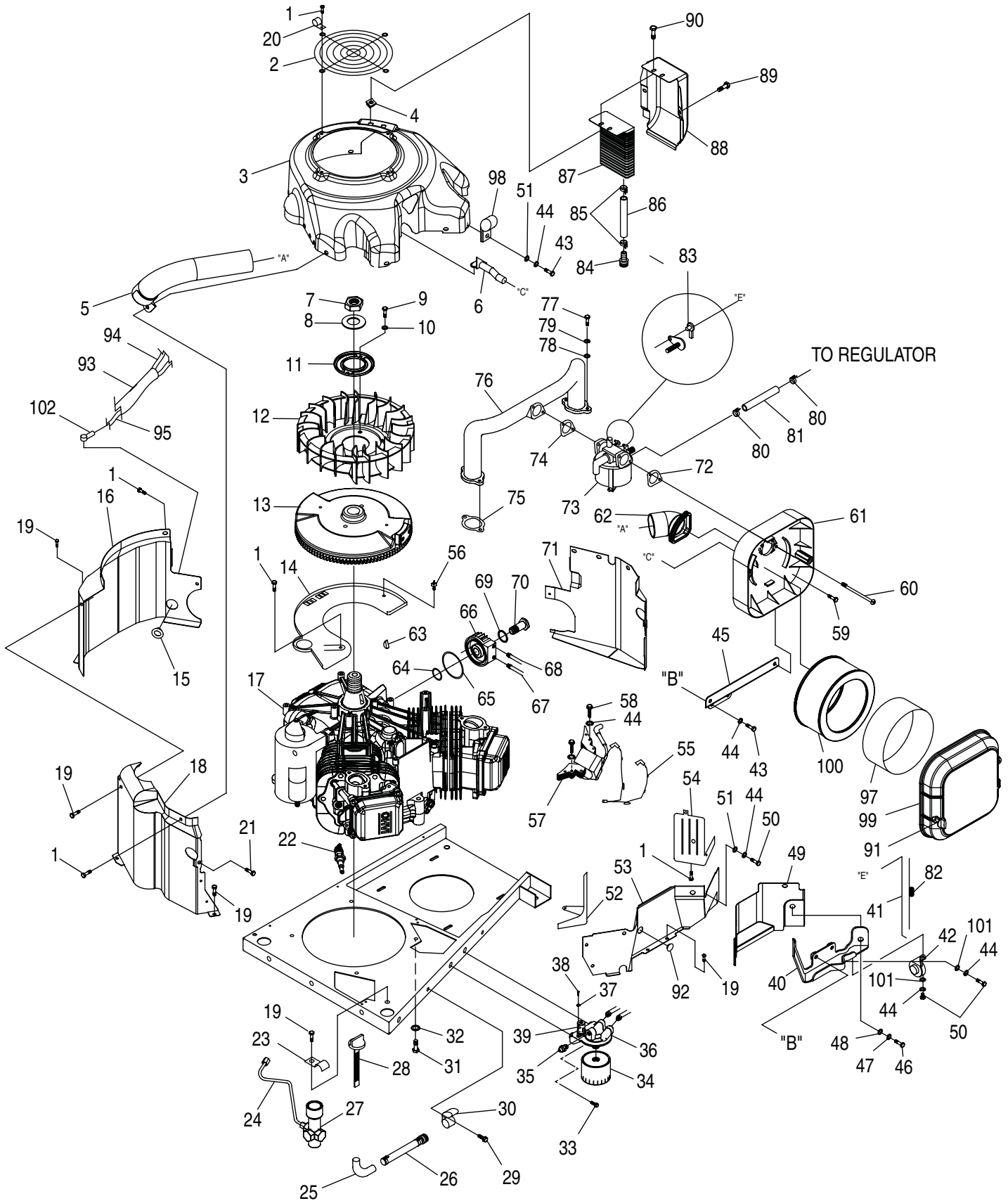

Section 8 – Exploded Views and Parts Lists

Air-cooled 11 kW Generators Engine Accessories – Drawing No. 0F2001-D

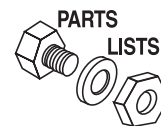

ITEM	PART NO.	QTY.	DESCRIPTION	ITEM	PART NO.	QTY.	DESCRIPTION
1	045756	11	SCREW HHTT M6-1.0 X 10 YC	53	0D9680A	1	WRAPPER, VALLEY SPCC
2	0D1131	1	GUARD, FAN	54	0D1143A	1	WRAPPER, UPPER #2 WITH M8 WELD NUT
3	0F1169G	1	HOUSING, BLOWER V-TWIN RV	55	0E7209	1	ASSEMBLY GROUNDING WIRE
4	0C9763	4	NUT, GROMMET 1/4 PLUG	56	0E4997	1	ASSEMBLY GROUND WIRE CONNECTOR
5	0E4386	1	TUBE, INTAKE	57	0D9852	2	ASSEMBLY IGNITION COIL
6	0E5079	1	HOSE, BREATHER	58	092079	4	SCREW HHTT M6-1.0 X 25mm BP
7	0C3034	1	NUT HEX M24-2.0 G8 YEL CHR	59	0A7215	2	SCREW SW 1/4"-20 X 5/8" WITH WASHER
8	0C3033	1	WASHER, BELLEVILLE 25MM BOLT	60	078643B	2	BOLT, CARB MOUNT M6-1.0 x85mm
9	051754	2	SCREW HHC M8-1.25 X 12 G8.8	61	0E4867	1	BASE, AIR CLEANER
10	0A5992	2	WASHER SHAKEPROOF INT M8 SS	62	0E5293	1	BOOT, INTAKE
11	0C3032	1	PLATE, FAN	63	082774	1	KEY, WOODRUFF 4 X 19D
12	0C3031	1	FAN NYLON	64	0C1547	1	O-RING 21.89 X 27.13 X 2.62mm
13	0C3725A	1	FLYWHEEL ASSEMBLY	65	0C1546	1	O-RING 59.92 X 66.98 X 3.53mm
14	0F1170A	1	PLATE, BACKING WITH OIL COOL	66	0A5358	1	ADPTR OIL PAD, FLARE
15	023484S	1	BUSHING SNAP	67	0D9312	1	TUBE, ENGINE OIL RETURN
16	0D9679A	1	WRAP, CRANKCASE SPCC	68	0D9314	1	TUBE, ENGINE OIL OUT
17	0E6481	1	GT990 VERTICAL SHAFT DUEL/FUEL ENGINE	69	0C1557	1	O-RING 20.35 X 23.91 X 1.78mm
18	0F1167A	1	WRAP, CYLINDER 1 SPCC	70	0A9028	1	BOLT, OIL ADAPTOR
19	056893	13	SCREW CRIMPTITE #10-24 X 1/2"	71	0D9682A	1	WRAPPER, CYLINDER #2 SPCC
20	055934M	1	CLAMP VINYL	72	0E0573	1	GASKET, CARB TO ADAPTOR
21	074908	2	SCREW HHTT M5-0.8 X 10mm BP	73	0E1217A	1	CARBURETOR
22	0E7585	2	SPARK PLUG	74	0E0572	1	GASKET, CARB TO INTAKE MANIFOLD
23	0E0998	1	CLAMP VINYL 9.5 O.D. TUBE	75	0C3043	2	GASKET INTAKE PORT
24	0E4871	1	TUBE, OIL PASSAGE	76	0D8836	1	MANIFOLD, INTAKE
25	043790	1	BARBED ELBOW 90 3/8NPT X 3/8	77	049821	4	SCREW SHC M8-1.25 X 30mm G12.9
26	0D3083	1	ASSEMBLY, OIL DRAIN HOSE	78	070008	4	WASHER FLAT M8 SS
27	0E0361A	1	OIL DRAIN / DIPSTICK TUBE	79	070006	4	WASHER LOCK M8 SS
28	0E0393	1	ASSEMBLY, CAP & DIP STICK	80	048031M	2	CLAMP HOSE
29	0C2824	1	SCREW TAP-R #10-32 X 9/16"	81	0F7065	18"	HOSE 1/2" I.D.
30	065852	1	SPRING CLIP HOLDER 0.37"-0.62"	82	0E6885	1	SPRING, ANTI-LASH
31	075246	4	SCREW HHTT 3/8"-16 X 1-1/4"	83	0D1366	1	BUSHING, GOVERNOR ROD
32	0A4456	1	WASHER LOCK SPECIAL 3/8	84	035461	2	BARBED STRAIT 1/4"NPT X 3/8"
33	0A2311	2	SCREW SWAGE 1/4"-20 X 1"	85	0F6301	4	CLAMP, HOSE OETIKER 16.5mm
34	070185B	1	OIL FILTER	86	0C9806	2	HOSE, 3/8" I.D. x 6"
35	0A8584	1	SWITCH OIL PRESSURE	87	0C3026	1	COOLER, OIL
36	0A5360	1	SUPPORT OIL FLTR FLARE	88	0D9683A	1	DUCT, OIL COOLER SPCC
37	043182	2	WASHER LOCK M3	89	0D6029	2	SCREW HHTT M6-1.0 X 16mm
38	0C1085	2	SCREW PPHM M3-0.5 X 8mm	90	0C9764	4	PLASTITE, 1/4"-15 X 3/4"
39	0E1497	1	SWITCH, OIL HIGH TEMPERATURE	91	0C3024	1	COVER, AIRBOX
40	0E3305	1	BRACKET, STEPPER MOTOR MOUNT	92	0E6314	1	PLUG PANEL PLASTIC 0.562"
41	0E5072	1	ROD, GOVERNOR	93	0E3077	1	SLEEVE 5/8" I.D. X 12.5" LONG
42	0E5108	1	CONTROLLER	94	0388050AH0	1	CABLE BATTERY BLACK #6 48"
43	047487	2	SCREW SHC M6-1.0 X 18mm	95	0388040AM0	1	CABLE BATTERY RED #6 48"
44	022097	12	WASHER LOCK M6-1/4"	96	0E7351	1	ENGINE HARNESS (NOT SHOWN)
45	0E4988	1	AIR BOX SUPPORT BRACKET	97	0C3040	1	PRE-CLEANER
46	055173	2	SCREW HHC M8-1.25 X 20mm G10.9	98	055934D	1	CLAMP VINYL 1.06" X 0.406" Z
47	022129	2	WASHER LOCK M8-5/16"	99	0C5136A	2	KNOB, AIR CLEANER
48	022145	2	WASHER FLAT 5/16"-M8 ZINC	100	0C8127	1	ELEMENT, AIR CLEANER
49	0D9801A	1	WRAP, VALLEY UPPER SPCC	101	049811	2	WASHER FLAT M6
50	047411	4	SCREW HHC M6-1.0 X 16mm	102	075763A	1	BOOT, BATTERY CABLE
51	022473	4	WASHER FLAT M6				
52	0C3018A	1	WRAPPER, UPPER #1 WITH M8 WELD NUT				

Section 8 – Exploded Views and Parts Lists

**Air-cooled 11 kW Generators
Alternator & Pulleys – Drawing No. 0E4880**

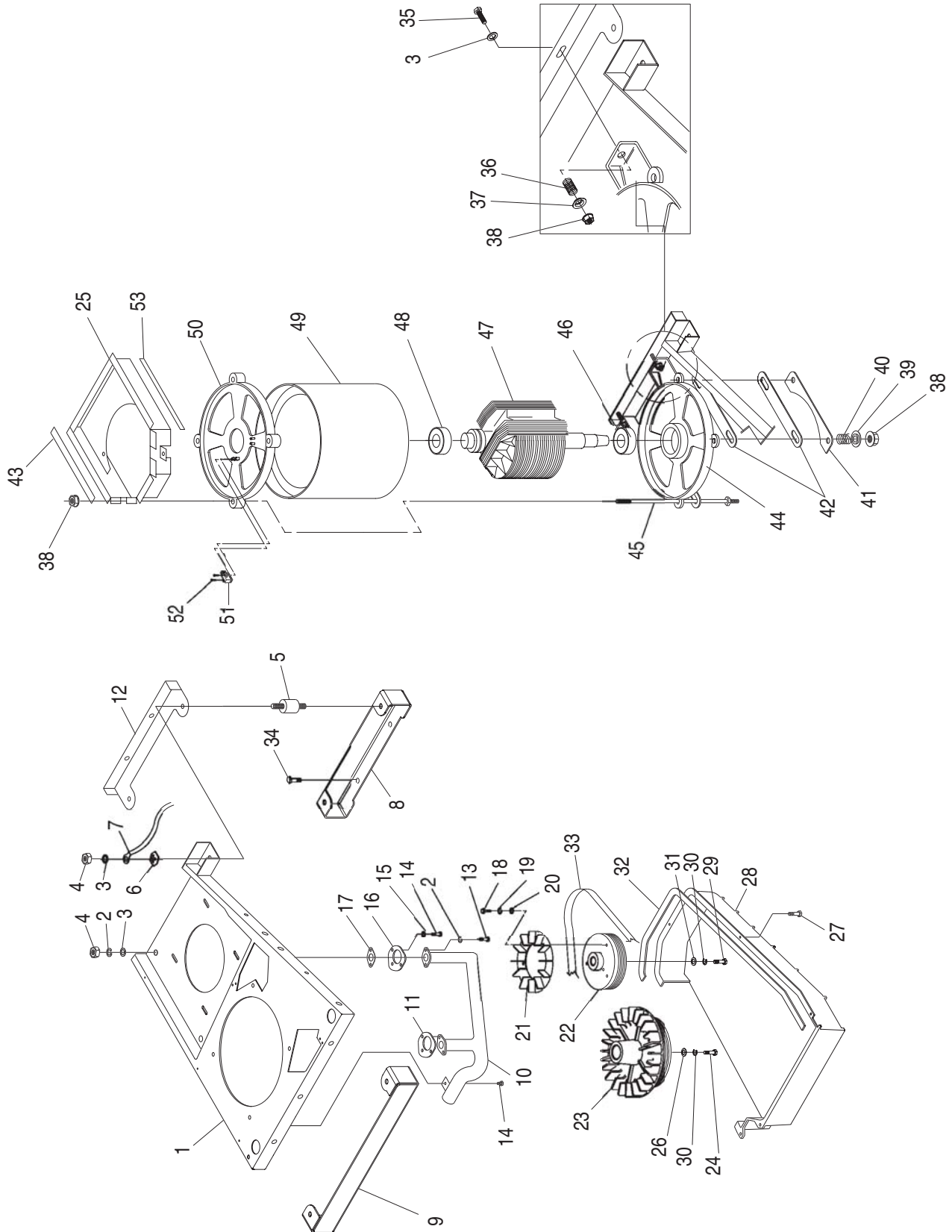

Section 8 — Exploded Views and Parts Lists

Air-cooled 11 kW Generators Alternator & Pulleys – Drawing No. 0E4880

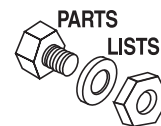

ITEM	PART NO.	QTY.	DESCRIPTION
1	0E0196A	1	FRAME, MOUNTING SS HSB
2	022129	7	WASHER LOCK M8-5/16
3	022145	8	WASHER FLAT 5/16-M8 ZINC
4	022259	4	NUT HEX 5/16-18 STEEL
5	0C7758	4	VIB MNT 1.5 X 1.38 X 5/16-18
6	0C3168	1	WASHER LOCK SPECIAL 5/16
7	0C2417	1	EARTH STRAP
8	0E2424A	1	SKID, MOUNT ALTERNATOR
9	0E2425	1	SKID, MOUNT ENGINE
10	0E2421	1	MANIFOLD, EXHAUST
11	0E1078A	1	GASKET, EXHAUST BASE
12	0E3020	1	BRACKET, FRAME EXTENSION
13	040976	4	SCREW SHC M8-1.25 X 20mm
14	056893	6	SCREW CRIMPTITE 10-24 X 1/2
15	023897	5	WASHER FLAT #10 ZINC
16	0E1078	1	GASKET, EXHAUST BASE
17	0C4138	2	GASKET, EXHAUST PORT
18	043116	3	SCREW HHC M6-1.0 X 12 G8.8
19	022097	3	WASHER LOCK M6-1/4
20	022473	3	WASHER FLAT 1/4-M6 ZINC
21	0C1752	1	FAN NYLON 8" DIA
22	0C1753B	1	PULLEY, ALTERNATOR 2200 RPM
23	075224D	1	PULLEY ENGINE 3600 RPM
24	073118	1	SCREW HHC 3/8"-24 X 2-1/4"
25	0E5984	1	DUCT, ALTERNATOR COVER
26	022131	1	WASHER FLAT 3/8-M10 ZINC
27	0C2824	6	SCREW TAP-R #10-32 X 9/16"
28	0A9827B	1	BLOWER HOUSING
29	042633	1	SCREW HHC 3/8"-24 X 1"
30	022237	2	WASHER LOCK 3/8"
31	049451	1	WASHER FLAT 0.406" I.D. X 1.62" O.D.
32	0C1441	1	SET, BLOWER HOUSING GASKET
33	0C1112	1	BELT, V-RIB 4LX42.75"
34	083512	4	SCREW HHTT M8-1.2 X 16mm
35	039288	2	SCREW HHC M8-1.25 X 55mm
36	029459	2	TENSION SPRING
37	075215	2	WASHER, SPRING CENTER
38	052858	10	NUT LOCK FLANGE M8-1.25
39	075237	4	WASHER, SPRING CENTER
40	075242	4	SPRING, MOUNT
41	0A9202	2	SUPPORT, SLIDE
42	0A9918	4	SLIDE, NYLON
43	0E0575	3.5 FT	FOAM SEALING STRIP 1"
44	0A9226	1	BEARING CARRIER LOWER
45	0E4748	4	STUD, STATOR
46	031971	1	BEARING
47	0E3233	1	ROTOR
48	073159	1	BEARING
49	0E3229	1	STATOR
50	0A9227	1	BEARING CARRIER UPPER
51	066386	1	ASSEMBLY, BRUSH HOLDER
52	066849	2	SCREW HHTT M5-0.8 x 16mm
53	056326	3.4'	TRIM VINYL BLACK

Section 8 – Exploded Views and Parts Lists

Air-cooled 11 kW Generators
Regulator – Drawing No. 0E4881-C

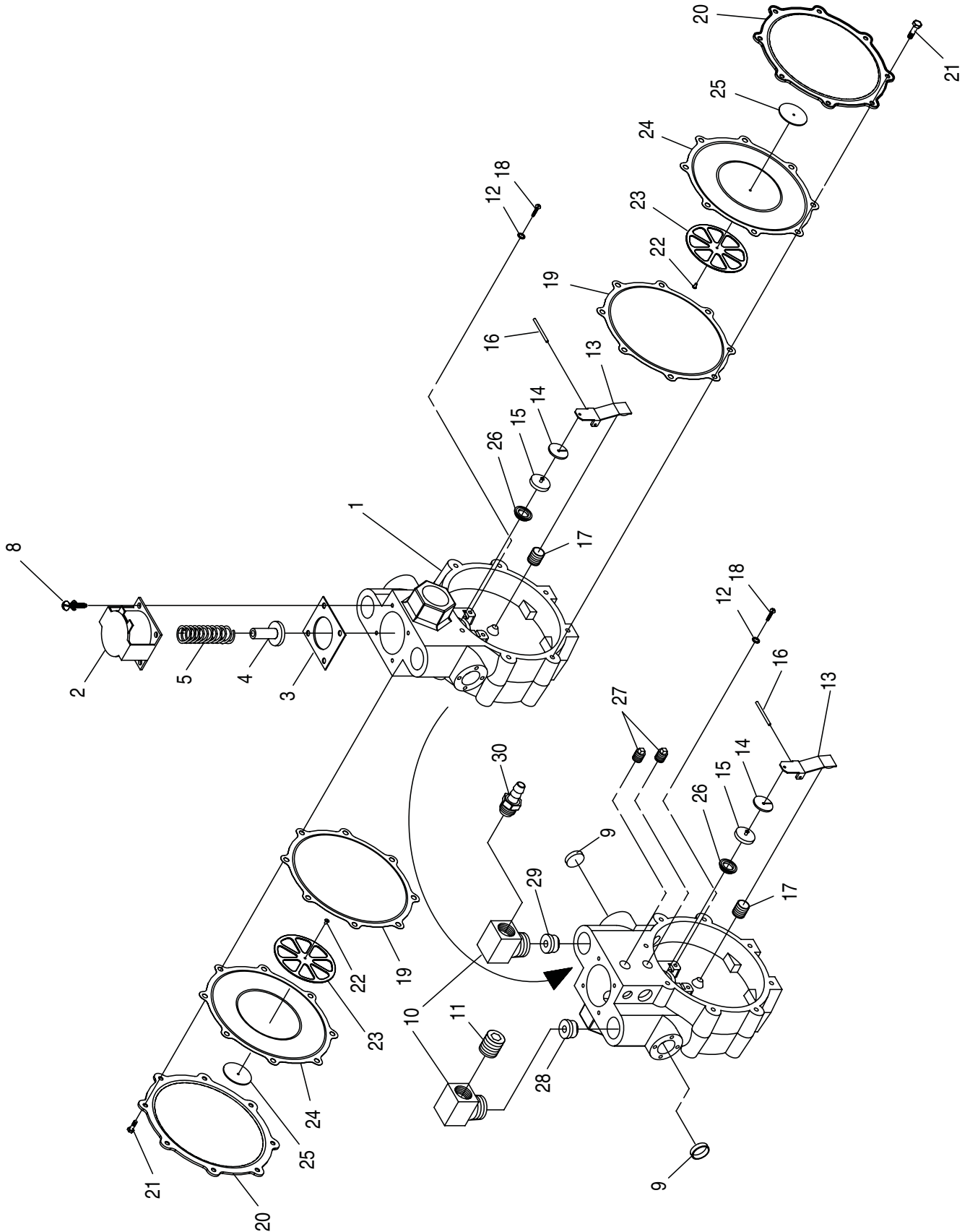

Section 8 – Exploded Views and Parts Lists

Air-cooled 11 kW Generators Regulator – Drawing No. 0E4881-C

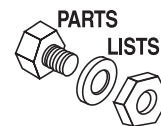

ITEM	PART NO.	QTY.	DESCRIPTION
1	0D5694	1	CASTING, TWIN REGULATOR HOUSING
2	0F5022	1	SOLENOID COIL, 12VDC
3	0C4647	1	GASKET , SOLENOID
4	0C4680	1	PLUNGER, LP REGULATOR ASSEMBLY
5	0C6070	1	SPRING-SOLENOID, PLUNGER
8	0F4795	4	SCREW PPHM SEMS M4-0.7 X 10
9	0D3973	2	PLUG, EXPANSION 16mm
10	0E6183	2	ELBOW 90D STREET 1/2"
11	0E6184	1	PLUG PIPE 1/2" COUNTERSUNK
12	0D3308	4	WASHER, FLAT M3 X 10mm O.D.
13	0C5761	2	LEVER, REGULATOR
14	0C5968	2	SUPPORT, INLET SEAL
15	0C6066	2	SEAL, INLET
16	0C5759	2	PIN, PIVOT ARM
17	0C5764	2	SPRING, REGULATOR
18	070728	4	SCREW, PFHMS M3-0.5 x 5
19	0C6069	2	GASKET, DIAPHRAGM
20	0C5762	2	COVER, TWIN REGULATOR
21	045764	16	SCREW, TAPTITE M4X8 BP
22	0C6731	2	RIVET, POP .118 X .125
23	0C6067	2	SUPPORT, DIAPHRAGM
24	0C4706	2	DIAPHRAGM, TWIN REGULATOR
25	0C6068	2	CAP, DIAPHRAGM SUPPORT
26	0C4643A	2	INLET, TWIN REGULATOR 11.11 DIA.
27	026073	2	PLUG, STANDARD PIPE 1/8 STEEL SQUARE HEAD
28	0E1010A	1	JET, GT990 LP GAS
29	0C5760G	1	JET, GT990 NAT GAS
30	0C6606	1	BARBED STR 1/2 X 1/2NPT



Section 10 – Warranty

Air-cooled 11 kW Generators

NOTE: This Emission Control Warranty Statement pertains to this product only IF the generator size is 15 kW or below.

CALIFORNIA EMISSION CONTROL WARRANTY STATEMENT

YOUR WARRANTY RIGHTS AND OBLIGATIONS

The California Air Resources Board (CARB) and Generac Power Systems, Inc. (Generac) are pleased to explain the Emission Control System Warranty on your new engine.* In California, new utility, and lawn and garden equipment engines must be designed, built and equipped to meet the state's stringent anti-smog standards. Generac will warrant the emission control system on your engine for the periods of time listed below provided there has been no abuse, neglect, unapproved modification or improper maintenance of your engine.

Your emission control system may include parts such as the carburetor, ignition system and exhaust system. Generac will repair your engine at no cost to you for diagnosis, replacement parts and labor, should a warrantable condition occur.

MANUFACTURER'S EMISSION CONTROL SYSTEM WARRANTY COVERAGE:

Emissions control systems on 1995 and later model year engines are warranted for two years as hereinafter noted. If, during such warranty period, any emission-related component or system on your engine is found to be defective in materials or workmanship, repairs or replacement will be performed by a Generac Authorized Warranty Service Facility.

PURCHASER'S/OWNER'S WARRANTY RESPONSIBILITIES:

As the engine purchaser/owner, you are responsible for the completion of all required maintenance as listed in your factory supplied *Owner's Manual*. For warranty purposes, Generac recommends that you retain all receipts covering maintenance on your engine. However, Generac cannot deny warranty solely due to the lack of receipts or for your failure to ensure the completion of all scheduled maintenance.

As the engine purchaser/owner, you should, however, be aware that Generac may deny any and/or all warranty coverage or responsibility if your engine, or a part/component thereof, has failed due to abuse, neglect, improper maintenance or unapproved modifications, or the use of counterfeit and/or "grey market" parts not made, supplied or approved by Generac.

You are responsible for contacting a Generac Authorized Warranty Service Facility as soon as a problem occurs. The warranty repairs should be completed in a reasonable amount of time, not to exceed 30 days.

Warranty service can be arranged by contacting either your selling dealer or a Generac Authorized Warranty Service Facility. To locate the Generac Authorized Warranty Service Facility nearest you, call our toll-free number:

1-800-333-1322

IMPORTANT NOTE: This warranty statement explains your rights and obligations under the Emission Control System Warranty (ECS Warranty), which is provided to you by Generac pursuant to California law. See also the "Generac Limited Warranties for Generac Power Systems, Inc.," which is enclosed herewith on a separate sheet, also provided to you by Generac. The ECS Warranty applies **only** to the emission control system of your new engine. If there is any conflict in terms between the ECS Warranty and the Generac Warranty, the ECS Warranty shall apply except in circumstances where the Generac Warranty may provide a longer warranty period. Both the ECS Warranty and the Generac Warranty describe important rights and obligations with respect to your new engine.

Warranty service can be performed only by a Generac Authorized Warranty Service Facility. When requesting warranty service, evidence must be presented showing the date of the sale to the original purchaser/owner.

If you have any questions regarding your warranty rights and responsibilities, you should contact Generac at one of the following addresses:

For Air-cooled Product ...

**ATTENTION WARRANTY DEPARTMENT
GENERAC POWER SYSTEMS, INC.
P.O. BOX 297
WHITEWATER, WI 53190**

Part 1

For Liquid-cooled Product ...

**ATTENTION WARRANTY DEPARTMENT
GENERAC POWER SYSTEMS, INC.
211 MURPHY DRIVE
EAGLE, WI 53119**



EMISSION CONTROL SYSTEM WARRANTY

Emission Control System Warranty (ECS Warranty) for 1995 and later model year engines:

- (a) Applicability: This warranty shall apply to 1995 and later model year engines. The ECS Warranty Period shall begin on the date the new engine or equipment is purchased by/delivered to its original, end-use purchaser/owner and shall continue for 24 consecutive months thereafter.
- (b) General Emissions Warranty Coverage: Generac warrants to the original, end-use purchaser/owner of the new engine or equipment and to each subsequent purchaser/owner that each of its engines is ...
- (1) Designed, built and equipped so as to conform with all applicable regulations adopted by the CARB pursuant to its authority, and
 - (2) Free from defects in materials and workmanship which, at any time during the ECS Warranty Period, may cause a warranted emissions-related part to fail to be identical in all material respects to the part as described in the engine manufacturer's application for certification.
- (c) The ECS Warranty only pertains to emissions-related parts on your engine, as follows:
- (1) Any warranted, emissions-related parts that are not scheduled for replacement as required maintenance in the *Owner's Manual* shall be warranted for the ECS Warranty Period. If any such part fails during the ECS Warranty Period, it shall be repaired or replaced by Generac according to Subsection (4) below. Any such part repaired or replaced under the ECS Warranty shall be warranted for the remainder of the ECS Warranty Period.
 - (2) Any warranted, emissions-related part that is scheduled only for regular inspection as specified in the *Owner's Manual* shall be warranted for the ECS Warranty Period. A statement in such written instructions to the effect of "repair or replace as necessary" shall not reduce the ECS Warranty Period. Any such part repaired or replaced under the ECS Warranty shall be warranted for the remainder of the ECS Warranty Period.
 - (3) Any warranted, emissions-related part that is scheduled for replacement as required maintenance in the *Owner's Manual* shall be warranted for the period of time prior to the first scheduled replacement point for that part. If the part fails prior to the first scheduled replacement, the part shall be repaired or replaced by Generac according to Subsection (4) below. Any such emissions-related part repaired or replaced under the ECS Warranty shall be warranted for the remainder of the ECS Warranty Period prior to the first scheduled replacement point for such emissions-related part.
 - (4) Repair or replacement of any warranted, emissions-related part under this ECS Warranty shall be performed at no charge to the owner at a Generac Authorized Warranty Service Facility.
 - (5) When the engine is inspected by a Generac Authorized Warranty Service Facility, the owner shall not be held responsible for diagnostic costs if the repair is deemed warrantable.
 - (6) Generac shall be liable for damages to other original engine components or approved modifications proximately caused by a failure under warranty of any emission-related part covered by the ECS Warranty.
 - (7) Throughout the ECS Warranty Period, Generac shall maintain a supply of warranted emission-related parts sufficient to meet the expected demand for such emission-related parts.
 - (8) Any Generac authorized and approved emission-related replacement part may be used in the performance of any ECS Warranty maintenance or repairs and will be provided without charge to the owner. Such use shall not reduce Generac ECS Warranty obligations.
 - (9) Unapproved, add-on, modified, counterfeit and/or "grey market" parts may not be used to modify or repair a Generac engine. Such use voids this ECS Warranty and shall be sufficient grounds for disallowing an ECS Warranty claim. Generac shall not be held liable hereunder for failures of any warranted parts of a Generac engine caused by the use of such an unapproved, add-on, modified, counterfeit and/or "grey market" part.

EMISSION RELATED PARTS INCLUDE THE FOLLOWING:

- | | |
|---|---|
| <ol style="list-style-type: none">1) Fuel Metering System:<ol style="list-style-type: none">1.2) LPG/Natural Gas carburetion assembly and its internal components.<ol style="list-style-type: none">a) Fuel controller (if so equipped)b) Mixer and its gaskets (if so equipped)c) Carburetor and its gaskets (if so equipped)d) Primary gas regulator (if so equipped)e) LP liquid vaporizer (if so equipped)2) Air Induction System including:<ol style="list-style-type: none">a) Intake pipe/manifoldb) Air cleaner | <ol style="list-style-type: none">3) Ignition System including:<ol style="list-style-type: none">a) Spark plugb) Ignition module4) Catalytic Muffler Assembly (if so equipped) including:<ol style="list-style-type: none">a) Muffler gasketb) Exhaust manifold5) Crankcase Breather Assembly including:<ol style="list-style-type: none">a) Breather connection tube |
|---|---|

*Generac engine types covered by this warranty statement include the following:

- 1) Prepackaged Standby Generator
- 2) Auxiliary Power Unit (APU) Generator
- 3) Standby Generator



Section 10 – Warranty

Air-cooled 11 kW Generators

GENERAC POWER SYSTEMS “TWO YEAR” LIMITED WARRANTY FOR QUIETSOURCE™ “PREPACKAGED EMERGENCY AUTOMATIC STANDBY GENERATORS”

For a period of two years from the date of original sale, Generac Power Systems, Inc. (Generac) warrants that its Quietsource generator will be free from defects in material and workmanship for the items and period set forth below. Generac will, at its option, repair or replace any part which, upon examination, inspection and testing by Generac or an Authorized Warranty Service Dealer, is found to be defective. Any equipment that the purchaser/owner claims to be defective must be examined by the nearest Authorized Warranty Service Dealer. All transportation costs under the warranty, including return to the factory, are to be borne and prepaid by the purchaser/owner. This warranty applies only to Generac Quietsource prepackaged emergency automatic standby generators sold and rated for use in “Standby” applications.

WARRANTY SCHEDULE

YEARS ONE and TWO - 100% (one hundred percent) transferable coverage on Labor and Part(s) listed (proof of purchase and maintenance is required):

Engine - All Components

Alternator - All Components

Transfer System - All Components

All warranty expense allowances are subject to the conditions defined in Generac’s Warranty Policies, Procedures and Flat Rate Manual.

THIS WARRANTY SHALL NOT APPLY TO THE FOLLOWING:

- Quietsource generators that utilize non-Generac/Quietsource replacement parts.
- Quietsource generators utilizing non-Generac/Quietsource automatic transfer switches.
- Repairs performed by individuals other than Guardian/Generac authorized dealers.
- Any Quietsource generators used as rental or trailer mounted applications.
- Air-cooled units used for prime power in place of existing utility power where utility power is present or in place of utility power where utility power service does not normally exist.
- Costs of normal maintenance, adjustments, installation and start-up.
- Failures caused by any contaminated fuels, oils, coolants or lack of proper fluid amounts.
- Failures due, but not limited, to normal wear and tear, accident, misuse, abuse, negligence or improper installation. As with all mechanical devices, the Generac engines need periodic part(s) service and replacement to perform well. This warranty will not cover repair when normal use has exhausted the life of a part(s) or engine.
- Failures caused by any external cause or act of God, such as collision, theft, vandalism, riot or wars, nuclear holocaust, fire, freezing, lightning, earthquake, windstorm, hail, volcanic eruption, water or flood, tornado or hurricane.
- Damage related to rodent and/or insect infestation.
- Products that are modified or altered in a manner not authorized by Generac in writing.
- Any incidental, consequential or indirect damages caused by defects in materials or workmanship, or any delay in repair or replacement of the defective part(s).
- Failure due to misapplication.
- Telephone, cellular phone, facsimile, internet access or other communication expenses.
- Living or travel expenses of person(s) performing service, except as specifically included within the terms of a specific unit warranty period.
- Expenses related to “customer instruction” or troubleshooting where no manufacturing defect is found.
- Rental equipment used while warranty repairs are being performed.
- Costs incurred for equipment used for removal and/or reinstallation of generator, (i.e.; cranes, hoists, lifts, etc.)
- Overnight freight costs for replacement part(s).
- Overtime labor.
- Starting batteries, fuses, light bulbs and engine fluids.

THIS WARRANTY IS IN PLACE OF ALL OTHER WARRANTIES, EXPRESSED OR IMPLIED. SPECIFICALLY, GENERAC MAKES NO OTHER WARRANTIES AS TO THE MERCHANTABILITY OR FITNESS FOR A PARTICULAR PURPOSE. Some states do not allow limitations on how long an implied warranty lasts, so the above limitation may not apply to you.

GENERAC’S ONLY LIABILITY SHALL BE THE REPAIR OR REPLACEMENT OF PART(S) AS STATED ABOVE. IN NO EVENT SHALL GENERAC BE LIABLE FOR ANY INCIDENTAL OR CONSEQUENTIAL DAMAGES, EVEN IF SUCH DAMAGES ARE A DIRECT RESULT OF GENERAC’S NEGLIGENCE. Some states do not allow the exclusion or limitation of incidental or consequential damages, so the above limitation may not apply to you.

This warranty gives you specific legal rights. You also have other rights from state to state.

GENERAC® POWER SYSTEMS, INC.
P.O. BOX 297 · WHITEWATER, WI 53190

Revision (10/01/04)

Free Manuals Download Website

<http://myh66.com>

<http://usermanuals.us>

<http://www.somanuals.com>

<http://www.4manuals.cc>

<http://www.manual-lib.com>

<http://www.404manual.com>

<http://www.luxmanual.com>

<http://aubethermostatmanual.com>

Golf course search by state

<http://golfingnear.com>

Email search by domain

<http://emailbydomain.com>

Auto manuals search

<http://auto.somanuals.com>

TV manuals search

<http://tv.somanuals.com>