

Serial Number

**2.4L
25kW
Models**

**STANDBY GENERATOR
OWNER'S MANUAL**

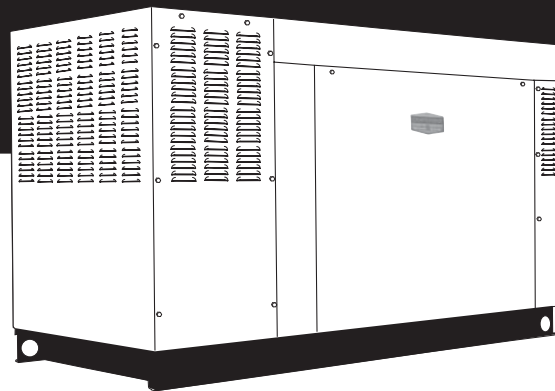

A new standard of reliability

⚠ Not intended for use in critical life support applications. ⚠

— ⚠ **CAUTION** ⚠ —

ONLY QUALIFIED ELECTRICIANS OR CONTRACTORS SHOULD ATTEMPT INSTALLATION!
DEADLY EXHAUST FUMES. OUTDOOR INSTALLATION ONLY!

This manual should remain with the unit.

SECTION	PAGE		PAGE
SAFETY RULES	1-1	OPERATION	9-1
INTRODUCTION	1-3	Generator Control and Operation	9-1
Read this Manual Thoroughly	1-3	Operating Unit with Manual Transfer Switch	9-1
Operation and Maintenance	1-3	Engine Start-up and Transfer	9-1
How to Obtain Service	1-3	Retransfer and Shutdown	9-1
IDENTIFICATION RECORD	2-1	Operating Unit with Automatic Transfer Switch	9-1
Data Label	2-1	MAINTENANCE	10-1
EQUIPMENT DESCRIPTION	3-1	Maintenance Performed by Authorized	
Equipment Description	3-1	Service Facilities	10-1
Engine Oil Recommendations	3-1	Every Three Months	10-1
Coolant Recommendations	3-1	Once Every Six Months	10-1
ENGINE PROTECTIVE DEVICES	4-1	Once Annually	10-1
High Coolant Temperature Switch	4-1	First 100 Operating Hours	10-1
Low Coolant Level Sensor	4-1	Every 500 Operating Hours	10-1
Low Oil Pressure Switch	4-1	Every 800 Operating Hours	10-1
Overcrank Shutdown	4-1	Exhaust Manifold Procedure	10-1
Overspeed Shutdown	4-1	Intake Manifold Procedure	10-1
RPM Sensor Loss Shutdown	4-1	Cylinder Head Procedure	10-1
DC Fuse	4-1	Cooling System	10-2
FUEL SYSTEMS	5-1	Overload Protection for Engine DC	
Fuel Requirements	5-1	Electrical System	10-2
Natural Gas Fuel System	5-1	Checking Fluid Levels	10-2
Propane Vapor Withdrawal Fuel System	5-1	Check Engine Oil	10-2
LP Fuel System	5-1	Battery Fluid	10-2
SPECIFICATIONS	6-1	Engine Coolant	10-2
Generator	6-1	Maintenance Owner/Operator Can Perform	10-3
Engine	6-1	Check Engine Oil Level	10-3
Cooling System	6-1	Check Battery	10-3
Fuel System	6-1	Exercise System	10-3
Electrical System	6-1	Inspect Cooling System	10-3
Cold Weather Kit	6-2	Check Engine Coolant Level	10-3
Reconfiguring the Fuel System	6-2	Perform Visual Inspection	10-3
GENERAL INFORMATION	7-1	Inspect Exhaust System	10-3
Generator AC Lead Connections	7-1	Check Fan Belt	10-3
Four-lead, Single-phase Stator	7-1	Inspect Engine Governor	10-3
Alternator Power Winding Connections	7-1	Changing Engine Oil	10-3
3-phase Alternators	7-1	Changing the Engine Air Cleaner	10-3
INSTALLATION	8-1	Spark Plugs	10-4
Installation	8-1	Coolant Change	10-4
Preparation Before Start-up	8-1	Miscellaneous Maintenance	10-4
Transfer Switch	8-1	Cleaning the Generator	10-4
Fuel System	8-1	Battery	10-4
Generator Set Lubrication	8-1	Battery Maintenance	10-4
Prior to Initial Start-up	8-1	Battery Replacement	10-5
Engine Coolant	8-1	SERVICE SCHEDULE	11-1
Belt Tension	8-1	TROUBLESHOOTING	12-1
Electrical System	8-1	Troubleshooting Guide	12-1
Initial Inspection for QT Genset Start-up	8-1	NOTES	
Start-up Checklist	8-2	EXPLODED VIEWS & PARTS LISTS	
Preparation for Start-up	8-2	WIRING DIAGRAMS & SCHEMATICS	
Start-up Inspection	8-2		



Standby Generator Sets Important Safety Instructions



⚠ SAVE THESE INSTRUCTIONS – *The manufacturer suggests that these rules for safe operation be copied and posted in potential hazard areas. Safety should be stressed to all operators, potential operators, and service and repair technicians for this equipment.* **⚠**



WARNING:



The engine exhaust from this product contains chemicals known to the state of California to cause cancer, birth defects or other reproductive harm.



WARNING:



This product contains or emits chemicals known to the state of California to cause cancer, birth defects or other reproductive harm.

Study these SAFETY RULES carefully before installing, operating or servicing this equipment. Become familiar with this Owner's Manual and with the unit. The generator can operate safely, efficiently and reliably only if it is properly installed, operated and maintained. Many accidents are caused by failing to follow simple and fundamental rules or precautions.

The manufacturer cannot anticipate every possible circumstance that might involve a hazard. The warnings in this manual, and on tags and decals affixed to the unit are, therefore, not all inclusive. If a procedure, work method or operating technique is used that the manufacturer does not specifically recommend, ensure that it is safe for others. Also make sure the procedure, work method or operating technique utilized does not render the generator unsafe.

⚠ DANGER ⚠

- ⚠** Despite the safe design of this generator, operating this equipment imprudently, neglecting its maintenance or being careless can cause possible injury or death. Permit only responsible and capable persons to install, operate or maintain this equipment.
- ⚠** Potentially lethal voltages are generated by these machines. Ensure all steps are taken to render the machine safe before attempting to work on the generator.
- ⚠** Parts of the generator are rotating and/or hot during operation. Exercise care near running generators.

⚠ GENERAL HAZARDS ⚠

- For safety reasons, the manufacturer recommends that this equipment be installed, serviced and repaired by a Service Dealer or other competent, qualified electrician or installation technician who is familiar with applicable codes, standards and regulations. The operator also must comply with all such codes, standards and regulations.
- Installation, operation, servicing and repair of this (and related) equipment must always comply with applicable codes, standards, laws and regulations. Adhere strictly to local, state and national electrical and building codes. Comply with regulations the Occupational Safety and Health Administration (OSHA) has established. Also, ensure that the generator is installed, operated and serviced in accordance with the manufacturer's instructions and recommendations. Following installation, do nothing that might render the unit unsafe or in noncompliance with the aforementioned codes, standards, laws and regulations.
- The engine exhaust fumes contain carbon monoxide gas, which can be DEADLY. This dangerous gas, if breathed in sufficient concentrations, can cause unconsciousness or even death. For that reason, adequate ventilation must be provided. Exhaust gases must be piped safely away from any building or enclosure that houses the generator to an area where people, animals, etc., will not be harmed. This exhaust system must be installed properly, in strict compliance with applicable codes and standards.
- Keep hands, feet, clothing, etc., away from drive belts, fans, and other moving or hot parts. Never remove any drive belt or fan guard while the unit is operating.
- Adequate, unobstructed flow of cooling and ventilating air is critical in any room or building housing the generator to prevent buildup of explosive gases and to ensure correct generator operation. Do not alter the installation or permit even partial blockage of ventilation provisions, as this can seriously affect safe operation of the generator.
- Keep the area around the generator clean and uncluttered. Remove any materials that could become hazardous.
- When working on this equipment, remain alert at all times. Never work on the equipment when physically or mentally fatigued.
- Inspect the generator regularly, and promptly repair or replace all worn, damaged or defective parts using only factory-approved parts.



Standby Generator Sets Important Safety Instructions



- Before performing any maintenance on the generator, disconnect its battery cables to prevent accidental start-up. Disconnect the cable from the battery post indicated by a NEGATIVE, NEG or (-) first. Reconnect that cable last.
- Never use the generator or any of its parts as a step. Stepping on the unit can stress and break parts, and may result in dangerous operating conditions from leaking exhaust gases, fuel leakage, oil leakage, etc.

ELECTRICAL HAZARDS

- All generators covered by this manual produce dangerous electrical voltages and can cause fatal electrical shock. Utility power delivers extremely high and dangerous voltages to the transfer switch as well as the standby generator. Avoid contact with bare wires, terminals, connections, etc., on the generator as well as the transfer switch, if applicable. Ensure all appropriate covers, guards and barriers are in place before operating the generator. If work must be done around an operating unit, stand on an insulated, dry surface to reduce shock hazard.
- Do not handle any kind of electrical device while standing in water, while barefoot, or while hands or feet are wet. DANGEROUS ELECTRICAL SHOCK MAY RESULT.
- If personnel must stand on metal or concrete while installing, operating, servicing, adjusting or repairing this equipment, place insulative mats over a dry wooden platform. Work on the equipment only while standing on such insulative mats.
- The National Electrical Code (NEC) requires the frame and external electrically conductive parts of the generator to be connected to an approved earth ground. This grounding will help prevent dangerous electrical shock that might be caused by a ground fault condition in the generator set or by static electricity. Never disconnect the ground wire.
- Wire gauge sizes of electrical wiring, cables and cord sets must be adequate to handle the maximum electrical current (ampacity) to which they will be subjected.
- Before installing or servicing this (and related) equipment, make sure that all power voltage supplies are positively turned off at their source. Failure to do so will result in hazardous and possibly fatal electrical shock.
- Connecting this unit to an electrical system normally supplied by an electric utility shall be by means of a transfer switch so as to isolate the generator electric system from the electric utility distribution system when the generator is operating. Failure to isolate the two electric system power sources from each other by such means will result in damage to the generator and may also result in injury or death to utility power workers due to backfeed of electrical energy.

- Generators installed with an automatic transfer switch will crank and start automatically when normal (utility) source voltage is removed or is below an acceptable preset level. To prevent such automatic start-up and possible injury to personnel, disable the generator's automatic start circuit (battery cables, etc.) before working on or around the unit. Then, place a "Do Not Operate" tag on the generator control panel and on the transfer switch.
- In case of accident caused by electric shock, immediately shut down the source of electrical power. If this is not possible, attempt to free the victim from the live conductor. AVOID DIRECT CONTACT WITH THE VICTIM. Use a nonconducting implement, such as a dry rope or board, to free the victim from the live conductor. If the victim is unconscious, apply first aid and get immediate medical help.
- Never wear jewelry when working on this equipment. Jewelry can conduct electricity resulting in electric shock, or may get caught in moving components causing injury.

FIRE HAZARDS

- Keep a fire extinguisher near the generator at all times. Do NOT use any carbon tetra-chloride type extinguisher. Its fumes are toxic, and the liquid can deteriorate wiring insulation. Keep the extinguisher properly charged and be familiar with its use. If there are any questions pertaining to fire extinguishers, consult the local fire department.

EXPLOSION HAZARDS

- Properly ventilate any room or building housing the generator to prevent build-up of explosive gas.
- Do not smoke around the generator. Wipe up any fuel or oil spills immediately. Ensure that no combustible materials are left in the generator compartment, or on or near the generator, as FIRE or EXPLOSION may result. Keep the area surrounding the generator clean and free from debris.
- These generator sets may operate using one of several types of fuels. All fuel types are potentially FLAMMABLE and/or EXPLOSIVE and should be handled with care. Comply with all laws regulating the storage and handling of fuels. Inspect the unit's fuel system frequently and correct any leaks immediately. Fuel supply lines must be properly installed, purged and leak tested according to applicable fuel-gas codes before placing this equipment into service.
- Diesel fuels are highly FLAMMABLE. Gaseous fluids such as natural gas and liquid propane (LP) gas are extremely EXPLOSIVE. Natural gas is lighter than air, and LP gas is heavier than air; install leak detectors accordingly.



INTRODUCTION

Thank you for purchasing this model of the standby generator set product line.

Every effort was expended to make sure that the information and instructions in this manual were both accurate and current at the time the manual was written. However, the manufacturer reserves the right to change, alter or otherwise improve this product(s) at any time without prior notice.

◆ READ THIS MANUAL THOROUGHLY

If any portion of this manual is not understood, contact the nearest Service Dealer for starting, operating and servicing procedures.

Throughout this publication, and on tags and decals affixed to the generator, DANGER, WARNING, CAUTION and NOTE blocks are used to alert personnel to special instructions about a particular service or operation that may be hazardous if performed incorrectly or carelessly. Observe them carefully. Their definitions are as follows:



After this heading, read instructions that, if not strictly complied with, will result in personal injury or property damage.



After this heading, read instructions that, if not strictly complied with, may result in personal injury or property damage.



After this heading, read instructions that, if not strictly complied with, could result in damage to equipment and/or property.

NOTE:

After this heading, read explanatory statements that require special emphasis.

These safety warnings cannot eliminate the hazards that they indicate. Common sense and strict compliance with the special instructions while performing the service are essential to preventing accidents.

Four commonly used safety symbols accompany the DANGER, WARNING and CAUTION blocks. The type of information each indicates is as follows:

 This symbol points out important safety information that, if not followed, could endanger personal safety and/or property of others.

 This symbol points out potential explosion hazard.

 This symbol points out potential fire hazard.

 This symbol points out potential electrical shock hazard.

The operator is responsible for proper and safe use of the equipment. The manufacturer strongly recommends that the operator read this Owner's Manual and thoroughly understand all instructions before using this equipment. The manufacturer also strongly recommends instructing other users to properly start and operate the unit. This prepares them if they need to operate the equipment in an emergency.

◆ OPERATION AND MAINTENANCE

It is the operator's responsibility to perform all safety checks, to make sure that all maintenance for safe operation is performed promptly, and to have the equipment checked periodically by a Service Dealer. Normal maintenance service and replacement of parts are the responsibility of the owner/operator and, as such, are not considered defects in materials or workmanship within the terms of the warranty. Individual operating habits and usage contribute to the need for maintenance service.

Proper maintenance and care of the generator ensure a minimum number of problems and keep operating expenses at a minimum. See a Service Dealer for service aids and accessories.

Operating instructions presented in this manual assume that the standby electric system has been installed by a Service Dealer or other competent, qualified contractor. Installation of this equipment is not a "do-it-yourself" project.

◆ HOW TO OBTAIN SERVICE

When the generator requires servicing or repairs, simply contact a Service Dealer for assistance. Service technicians are factory-trained and are capable of handling all service needs.

When contacting a Service Dealer about parts and service, always supply the complete model number of the unit as given on the front cover of this manual or on the DATA LABEL affixed to the unit.

IDENTIFICATION RECORD

◆ DATA LABEL

Every generator set has a DATA LABEL that contains important information pertinent to the generator. The data label, which can be found attached to the generator's lower connection box, lists the unit's serial number and its rated voltage, amps, wattage capacity, phase, frequency, rpm, power factor, etc.

NOTE:

For actual information related to this particular model, please refer to the Manual Drawing Listing located at the end of this manual, or to the data label affixed to the unit.

✦ Generator Model and Serial Number

This number is the key to numerous engineering and manufacturing details pertaining to your unit. Always supply this number when requesting service, ordering parts or seeking information.

Data Label

MODEL	<input type="text"/>	SERIAL	<input type="text"/>
CAT/CUST NO	<input type="text"/>	PROD DATE	<input type="text"/>
KW	<input type="text"/>	KVA	<input type="text"/>
PHASE	<input type="text"/>	HERTZ	<input type="text"/>
VOLT	<input type="text"/>	AMP	<input type="text"/>
PWR FACT	<input type="text"/>	ALT RPM	<input type="text"/>
ENG RPM	<input type="text"/>		
ALT SUBTRANS REACTANCE	<input type="text"/>	ALT TRANS REACTANCE	<input type="text"/>
CLASS <input type="checkbox"/> ROTOR <input type="checkbox"/> STATOR WINDING INS AT 25°C AMB			
<input type="text"/>		<input type="text"/>	
MODEL NO		SERIAL NO	
<input type="text"/>			
<input type="text"/>			
MANUFACTURING INFORMATION			

EQUIPMENT DESCRIPTION

This equipment is a revolving field, alternating current generator set. It is powered by a gaseous fueled engine operating at 1800 rpm for 4-pole direct drive units, 3600 rpm for 2-pole direct drive units and 2300 - 3000 rpm for quiet drive gear units. See the Specifications section for exact numbers. The unit comes complete with a sound attenuated enclosure, internally mounted muffler, control console, main-line circuit breaker, battery charger, and protective alarms as explained in the following paragraph.

All AC connections, including the power leads from the alternator, 120 volt battery charger input and control connections to the transfer switch are available in the main connection box.

The generator incorporates the following generator features:

- Rotor and Stator insulation is Class F rated as defined by NEMA MG1-32.6, NEMA MG1-1.66. The generator is self ventilated and drip-proof constructed.
- The voltage waveform deviation, total harmonic content of the AC waveform and telephone influence factor have been evaluated and are acceptable according to NEMA MG1-32.

ENGINE OIL RECOMMENDATIONS

The unit has been filled with 15W-40 engine oil at the factory. Use a high-quality detergent oil classified "For Service SJ or SH." Detergent oils keep the engine cleaner and reduce carbon deposits. Use oil having the following SAE viscosity rating, based on the ambient temperature range anticipated before the next oil change:

Temperature	Oil Grade (Recommended)
Above 80° F (27° C)	SAE 30W or 15W-40
32° to 80° F (0° to 27° C)	SAE 20W-20 or 15W-40
Below 32° F (0° C)	See Note

CAUTION

- ⚠ Any attempt to crank or start the engine before it has been properly serviced with the recommended oil may result in an engine failure.

NOTE:

For temperatures below 32° F, it is strongly recommended to use the optional Cold Weather Start Kit (part number listed in the Specification Section). The oil grade for temperatures below 32° F is 5W-30 synthetic oil.

COOLANT RECOMMENDATIONS

Use a mixture of half low silicate ethylene glycol base anti-freeze and deionized water. Cooling system capacity is listed in the specifications. Use only deionized water and only low silicate anti-freeze. If desired, add a high quality rust inhibitor to the recommended coolant mixture. When adding coolant, always add the recommended 50-50 mixture.

CAUTION

- ⚠ Do not use any chromate base rust inhibitor with ethylene glycol base anti-freeze or chromium hydroxide ("green slime") forms and will cause overheating. Engines that have been operated with a chromate base rust inhibitor must be chemically cleaned before adding ethylene glycol base anti-freeze. Using any high silicate anti-freeze boosters or additives will also cause overheating. The manufacturer also recommends that any soluble oil inhibitor is NOT used for this equipment.

DANGER

- ⚠ Do not remove the radiator pressure cap while the engine is hot or serious burns from boiling liquid or steam could result.
- ⚠ Ethylene glycol base antifreeze is poisonous. Do not use mouth to siphon coolant from the radiator, recovery bottle or any container. Wash hands thoroughly after handling. Never store used antifreeze in an open container because animals are attracted to the smell and taste of antifreeze even though it is poisonous to them.

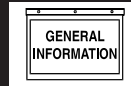
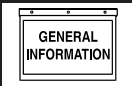

ENGINE PROTECTIVE DEVICES

The standby generator may be required to operate for long periods of time without an operator on hand to monitor such engine conditions as coolant temperature, oil pressure or rpm. For that reason, the engine has several devices designed to protect it against potentially damaging conditions by automatically shutting down the unit when the oil pressure is too low, the coolant temperature is too high, the coolant level is too low, or the engine is running too fast.

NOTE:

Engine protective switches and sensors are mentioned here for the reader's convenience. Also refer to the applicable control panel manual for additional automatic engine shutdown information.

◆ HIGH COOLANT TEMPERATURE SWITCH

This switches contacts close if the temperature should exceed approximately 140° C (284° F), initiating an engine shutdown. The generator will automatically restart and the LED will reset once the temperature has returned to a safe operating level.

◆ LOW COOLANT LEVEL SENSOR

Should the engine coolant level drop below the level of the high coolant temperature switch, it is possible for the engine to overheat without automatic shutdown. To prevent such overheating, the engine has a low coolant level sensor. If the level of engine coolant drops below the level of the low coolant level sensor, the engine automatically shuts down.

◆ LOW OIL PRESSURE SWITCH

This switch has normally closed contacts that are held open by engine oil pressure during cranking and operating. Should oil pressure drop below the 8 psi range, switch contacts close, and the engine shuts down. The unit should not be restarted until oil is added, and the AUTO/OFF/MANUAL switch must be turned to OFF and then back to AUTO.

◆ OVERCRANK SHUTDOWN

After a prespecified duration of cranking, this function ends the cranking if the engine has failed to start. The overcrank LED will turn ON. Turn OFF the AUTO/OFF/MANUAL switch, then turn switch back to AUTO to reset the generator control board.

NOTE:

If the fault is not corrected, the overcrank feature will continue to activate.

Approximate Crank Cycle Times

- 15 seconds ON
 - 7 seconds OFF
 - 7 seconds ON
 - 7 seconds OFF
 - Repeat for 45 seconds
- Approximately 90 seconds total.

◆ OVERSPEED SHUTDOWN

A speed circuit controls engine cranking, start-up, operation and shutdown. Engine speed signals are delivered to the circuit board whenever the unit is running. Should the engine overspeed above a safe, preset value, the circuit board initiates an automatic engine shutdown. Contact the nearest Authorized Dealer if this failure occurs.

◆ RPM SENSOR LOSS SHUTDOWN

If the speed signal to the control panel is lost, engine shutdown will occur.

◆ DC FUSE

This fuse is located inside of the control panel. It protects the panel wiring and components from damaging overload. **Always remove this fuse before commencing work on the generator.** The unit will not start or crank if the fuse is blown. Replace the fuse with one of the same size, type, and rating. (See the exploded views and parts lists at the end of this manual for replacement part number.)

FUEL SYSTEM

◆ FUEL REQUIREMENTS

The standby generator may be equipped with one of the following fuel systems:

- Natural gas fuel system
- Propane vapor (PV) fuel system

The Manual Drawing Listing that is affixed to the unit includes the "Identification Code," which may be used to identify the type of fuel system installed on the unit.

Recommended fuels should have a Btu content of at least 1,000 Btus per cubic foot for natural gas; or at least 2,520 Btus per cubic foot for LP gas. Ask the fuel supplier for the Btu content of the fuel.

Required fuel pressure for **natural gas is 5 inches to 14 inches water column (0.18 to 0.5 psi); and for liquid propane, 5 inches to 14 inches of water column (0.18 to 0.5 psi).**

NOTE:

Any piping used to connect the generator to the fuel supply should be of adequate size to ensure the fuel pressure NEVER drops below five inches water column for natural gas or 5 inches water column for propane vapor for all load ranges.

NOTE:

It is the responsibility of the installer to make sure that only the correct recommended fuel is supplied to the generator fuel system. Thereafter, the owner/operator must make certain that only the proper fuel is supplied.

◆ NATURAL GAS FUEL SYSTEM

Natural gas is supplied in its vapor state. In most cases, the gas distribution company provides piping from the main gas distribution line to the standby generator site. The following information applies to natural gas fuel systems.

- Gas pressure in a building is usually regulated by national, state and local codes.
- To reduce gas pressure to a safe level before the gas enters a building, a primary regulator is needed. The natural gas supplier may or may not supply such a regulator.
- It is the responsibility of the gas supplier to make sure sufficient gas pressure is available to operate the primary regulator.
- Gas pressure at the inlet to the fuel shutoff solenoid should not exceed approximately 14 inches water column (0.5 psi). Optimum pressure at the fuel shutoff solenoid is 11 inches water column (0.4 psi).

◆ PROPANE VAPOR WITHDRAWAL FUEL SYSTEM

This type of system utilizes the vapors formed above the liquid fuel in the supply tank. Approximately 10 to 20 percent of the tank capacity is needed for fuel expansion from the liquid to the vapor state. The vapor withdrawal system is generally best suited for smaller engines that require less fuel. The installer should be aware of the following:

- The natural gas and LP gas systems are similar. However, the natural gas system delivers gas at a pressure of approximately five inches water column to the carburetor.
- When ambient temperatures are low and engine fuel consumption is high, the vapor withdrawal system may not function efficiently.
- Ambient temperatures around the supply tank must be high enough to sustain adequate vaporization, or the system will not deliver the needed fuel volume.
- In addition to the cooling effects of ambient air, the vaporization process itself provides an additional cooling effect.

◆ LP FUEL SYSTEM

LP is supplied as a liquid in pressure tanks. It is usually made up of propane, butane, or a mixture of the two gases. Propane tends to vaporize readily even at temperatures as low as -20° F (-29° C). However, butane reverts to its liquid state when temperatures drop below 32° F (0° C).

LP in a liquid withdrawal system must be converted to its gaseous state before it is introduced into the engine carburetor. A vaporizer-converter is generally used to accomplish this. In such a converter, heated engine coolant is ported through the converter to provide the necessary heat for conversion of the fuel from a liquid to a gaseous state.

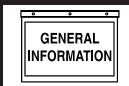

Standby Generator Sets Specifications

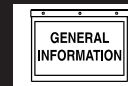

SPECIFICATIONS

◆ GENERATOR

Type Synchronous
 Rotor Insulation Class F
 Stator Insulation Class H
 Total Harmonic Distortion <5%
 Telephone Interference Factor (TIF) < 50
 Alternator Output Leads 3-phase 6-wire
 Bearings Sealed Ball
 Coupling Flexible Disc
 Load Capacity (Standby Rating) 25kW*

* NOTE: Generator rating and performance in accordance with ISO8528-5, BS5514, SAE J1349, ISO3046 and DIN 6271 Standards. KW rating is based on LPG fuel and may derate with natural gas.

Excitation System.....	Direct
Generator Output Voltage/kW - 60 Hz	<u>kW</u> <u>Amp</u> <u>CB Size</u>
120/240V, 1-phase, 1.0 pf	25 104 125
120/208V, 3-phase, 0.8 pf	25 87 100
277/480V, 3-phase, 0.8 pf	25 38 40
Generator Locked Rotor KVA Available @ Voltage Dip of 35%	
Single-phase	50 KVA
208V, 3-phase	70 KVA
480V, 3-phase	70 KVA

◆ ENGINE

Make Generac
 Model In Line
 Cylinders and Arrangement..... 4
 Displacement..... 2.4 Liter
 Bore 3.41 in.
 Stroke 3.94 in.
 Compression Ratio..... 8.5-to-1
 Air Intake System Naturally Aspirated
 Valve Seats..... Hardened
 Lifter Type Hydraulic

Engine Parameters

Rated Synchronous RPM..... 60 Hz, 1800
 HP at rated kW..... 60 Hz, 40

Exhaust System

Exhaust Flow at Rated Output 60 Hz..... 130 cfm
 Exhaust Temperature at Rated Output..... 900° F

Combustion Air Requirements (Natural Gas)

Flow at rated power, 60 Hz 70 cfm

Governor

Type Electronic
 Frequency Regulation Isochronous
 Steady State Regulation..... ± 0.25%

Engine Lubrication System

Type of Oil Pump..... Gear
 Oil Filter Full Flow Spin-on, Cartridge
 Crankcase Oil Capacity..... 4 U.S. qts.

◆ COOLING SYSTEM

Type Pressurized Closed Recovery
 Water Pump..... Belt Driven
 Fan Speed 1000 rpm
 Fan Diameter..... 22 inches
 Fan Mode Puller
 Air Flow (inlet air including alternator and combustion air)..... 1600 ft³/min.
 Coolant Capacity (3.0 U.S. gal.)
 Heat Rejection to Coolant 106,900 Btu/h
 Maximum Operating Air Temp. on Radiator 60° C (150° F)
 Maximum Ambient Temperature..... 50° C (140° F)

◆ FUEL SYSTEM

Type of Fuel..... Natural Gas, Propane Vapor
 Carburetor Down Draft
 Secondary Fuel Regulator Standard
 Fuel Shut-off Solenoid..... Standard
 Operating Fuel Pressure 5 in. - 14 in. Water Column

Fuel Consumption - ft³/hr (Natural Gas/LPV)

<i>Exercise</i>	<i>25%</i>	<i>50%</i>	<i>75%</i>	<i>100%</i>
<i>Cycle</i>	<i>Load</i>	<i>Load</i>	<i>Load</i>	<i>Load</i>
42/16	107/41	204/77	293/111	375/142

◆ ELECTRICAL SYSTEM

Battery Charge Alternator 12V, 30 Amp
 Static Battery Charger..... 2 Amp
 Recommended Battery..... Group 26, 525CCA
 System Voltage..... 12 Volts

Voltage Regulator

Type Electronic
 Sensing..... Single-phase
 Regulation ± 1%
 Features V/F Adjustable, Adjustable Voltage and Gain LED Indicators

Power Adjustment for Ambient Conditions

Temperature Deration
 3% for every 10° C above °C 25
 1.65% for every 10° above °F 77
 Altitude Deration
 1% for every 100 m above m 183
 3% for every 1000 ft. above ft. 600

Controller **R-200**

Figure 1 — Interconnections

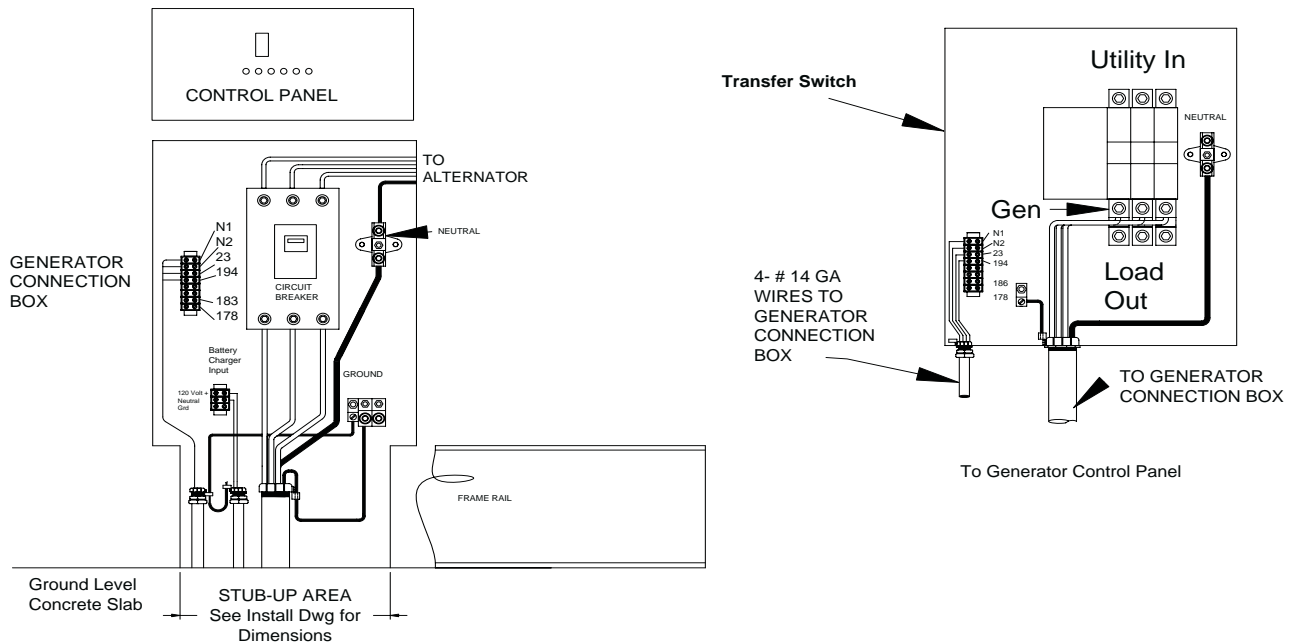

◆ COLD WEATHER KIT

For cold climates, optional cold weather kit (part number 0F6148) is recommended. The kit includes:

- Battery Warmer
- 4" Junction Box with hardware
- 6 qt. pack 5W-30 synthetic oil (engine)

◆ RECONFIGURING THE FUEL SYSTEM

NOTE:

All models are configured to run on natural gas from the factory.

To reconfigure the fuel system from NG to LP, follow these steps:

1. Turn the main gas supply off.
2. Remove the carburetor fuel hose from the outlet port of the demand regulator (see Figure 6.2).
3. Disconnect the power wires from the fuel solenoid located on top of the regulator assembly.
4. Loosen the spring clamp on the small fuel enrichment line and remove the hose from the hose barb.
5. Remove the black pipe assembly from the outlet port of the demand regulator.
6. Remove the NG fuel jet (loosen counter clockwise) from the outlet port.
7. Remove the LP fuel jet (loosen counter clockwise) from the jet keeper port on the side of the regulator housing. Install this jet into the outlet port in the regulator casting.

NOTE:

The jet sizes are stamped on the individual jets. The larger jet size is used for running on NG.

8. Install the previously removed NG jet into the jet keeper port on the side of the regulator housing.
9. Install the previously removed black pipe onto the outlet port of the demand regulator.
10. Reverse steps 1-4 in this procedure to reactivate the demand regulator.

Figure 6.2 — Reconfigure the Fuel System

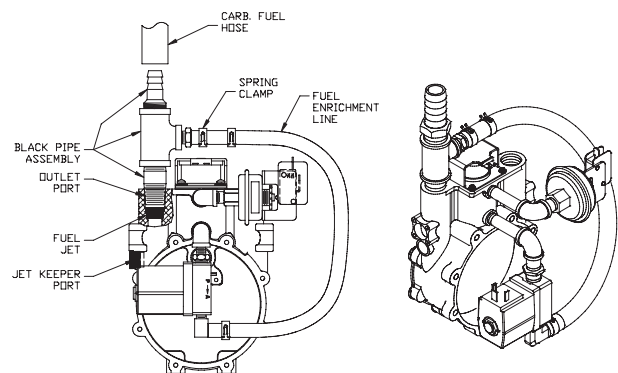

⚠ DANGER ⚠

⚠ Serious injury or damage may occur if not configured properly. Please consult an Authorized Dealer with any questions.

GENERATOR AC LEAD CONNECTIONS

See "Voltage Codes". This generator may be rated at any one of three voltages, either single-phase or three-phase. The electrical wires in the unit's AC connection (lower) panel should be installed according to the number of leads and the voltage/phase required for the application. If there are any questions regarding lead connection, refer to the wiring diagrams at the back of this manual.

Voltage codes apply to the type of stator assembly installed on a particular generator.

◆ FOUR-LEAD, SINGLE-PHASE STATOR

Four-lead generators (see Figure 7.1) are designed to supply electrical loads with voltage code "A" (240V, 1-phase, 60 Hz). Electrical power is produced in the stator power windings. These windings were connected at the factory to the main circuit breaker as shown in Figure 7.1.

The rated voltage between each circuit breaker terminal is 240V. The rated voltage between each circuit breaker terminal and the neutral point 00 is 120V.

Figure 7.1 — Four-lead, Single-phase Stator

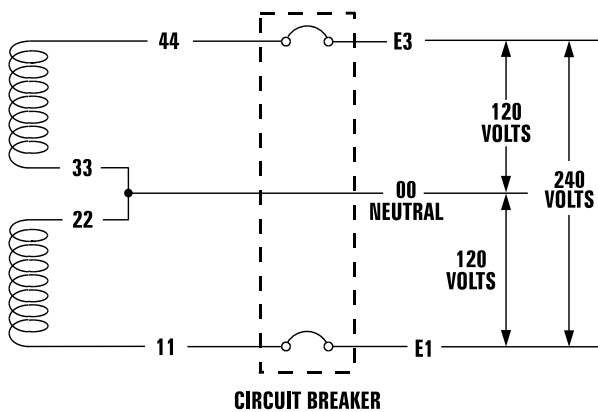

ALTERNATOR POWER WINDING CONNECTIONS

◆ 3-PHASE ALTERNATORS

The generator is designed to supply 3-phase electrical loads. Electric power is produced in the alternator power windings. These windings were connected at the factory to the main circuit breaker with a "Y" configuration as shown in Figures 7.2 and 7.3.

The rated voltage between circuit breaker terminals E1-E2, E1-E3 and E2-E3 is either 480V or 208V depending on the model.

The rated voltage between each circuit breaker terminal and the neutral point 00 is either 277V or 120V depending on the model.

Figure 7.2 — Stator Power Winding Connections - 3-phase, 277/480V (6 Lead)

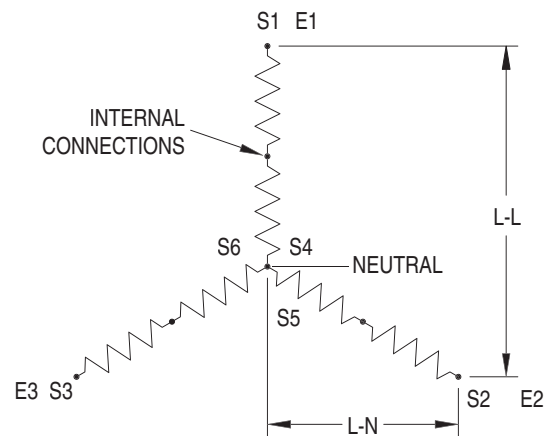
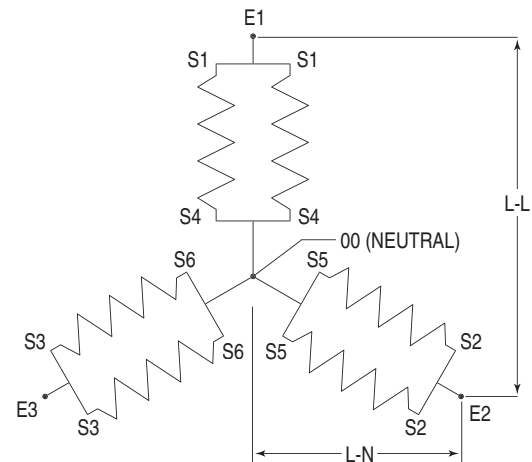

Figure 7.3 — Stator Power Winding Connections - 3-phase, 120/208V (6 Lead)





INSTALLATION

Refer to the separate "Installation Guide" supplied with the unit.

PREPARATION BEFORE START-UP

The instructions in this section assume that the standby generator has been properly installed, serviced, tested, adjusted and otherwise prepared for use by a competent, qualified installation contractor. Be sure to read the "Safety Rules", as well as all other safety information in this manual, before attempting to operate this (and related) equipment.

Before starting the generator for the first time, the installer must complete the following procedures. For follow-up maintenance information and/or service intervals, please refer to the "Maintenance" section and the "Service Schedule".

◆ TRANSFER SWITCH

If this generator is used to supply power to any electrical system normally powered by an electric utility, the National Electrical Code requires that a transfer switch be installed. The transfer switch prevents electrical backfeed between two different electrical systems. (For additional information, see the applicable transfer switch manual for this unit.) The transfer switch, as well as the generator and other standby components, must be properly located and mounted in strict compliance with applicable codes, standards and regulations.

◆ FUEL SYSTEM

Make sure the fuel supply system to the generator (a) delivers the correct fuel at the correct pressure and (b) is properly purged and leak tested according to code. No fuel leakage is permitted. See "Specifications" for more information.

◆ GENERATOR SET LUBRICATION

Check the engine crankcase oil level before operating and add oil to the proper level – the dipstick "FULL" mark. Never operate the engine with the oil level below the dipstick "ADD" mark. See "Specifications" and "Engine Oil Recommendations".

NOTE:

This engine is shipped from the manufacturer with "break-in" oil. This oil should be changed after 30 hours of operation.

◆ PRIOR TO INITIAL START-UP



- ⚠ Prior to initially starting the generator, it must be properly prepared for use. Any attempt to crank or start the engine before it has been properly serviced with the recommended types and quantities of engine fluids (oil, coolant, fuel, etc.) may result in an engine failure.

◆ ENGINE COOLANT

Have the engine cooling system properly filled with the recommended coolant mixture. Check the system for leaks and other problems. See "Specifications" and "Coolant" sections.

◆ BELT TENSION

Check the engine-fan belt tension and condition prior to placing the unit into service and at recommended intervals. Belt tension is correct when a force of approximately 22 pounds (10 kg), applied midway between pulleys, deflects the belt about 3/8- to 5/8-inch (10 to 16 mm).

◆ ELECTRICAL SYSTEM

Make sure the generator is properly connected to an approved earth ground.

Make sure the generator battery is fully charged, properly installed and interconnected, and ready for use.

NOTE:

Battery charger must be connected to 120 VAC, 15 amp circuit to operate.

Check to ensure that there are no loose electrical connections. Restrain any loose wires to keep them clear of any moving generator set components.

INITIAL INSPECTION FOR GENSET STARTUP

Inspect for the following.

- Freight Damage.
- Manuals present.
- Fluid Levels (Oil, coolant, battery, Gear Drive).
- Correct fuel piping.
- Adequate air flow, clearances and ventilation per installation drawings and applicable codes.
- Correct AC and DC wire size, connections and grounding. Control and communication wiring to/from the transfer switch must be run in a separate conduit from the AC power leads.



- **Battery charger connection to 120 VAC.**
- Communication wires connected between transfer switch and generator (HTS only).
- Unit secured to pad.

START-UP CHECKLIST



WARNING

⚠ Before working on the generator, ensure the following:

- **The AUTO/OFF/MANUAL switch is in the OFF position.**
- **The 120VAC supply to the battery charger is switched OFF.**

◆ PREPARATION FOR START-UP

- Ensure that the 120VAC circuit breaker to the battery charger is open.
- Remove the fuse from the the control panel. Open the front door of the control box and remove the 15 Amp ATO fuse in the lower left-hand corner of the control box.
- Connect the battery cables to the battery. Attach negative battery cable last.
- Close the 120VAC circuit breaker to the battery charger.
- Measure the voltage at the battery before and after the charger is turned on.
- Verify all AC electrical connections are tight at the circuit breaker and transfer switch.
- Visually inspect entire area looking for loose paper, plastic wrappings, leaves, etc.
- Check all hoses clamps fittings for leaks or damage.
- Check all electrical plugs throughout the generator. Ensure each plug is seated correctly and fully inserted into its receptacle.
- Verify the AUTO/OFF/MANUAL switch is in OFF position.
- Open the valve to the engine fuel line.
- Bleed the fuel system of air. (necessary for long fuel lines).
- Open the generator main line circuit breaker.
- Connect a manometer to the gas line and record the static pressure. It must be as listed in the Specifications.
- Insert the fuse into the control panel.
- Move the AUTO/OFF/MANUAL switch to the manual position. The engine should now crank and start.
- Check voltage at the generator terminals.
- For 3-phase units, check phase rotation at the transfer switch terminals. The generator phase rotation must match the utility phase rotation.
- Check for coolant, fuel, oil, and exhaust leaks.
- Close the generators main line circuit breaker.
- Turn the generator set off.
- Connect the UTILITY supply to the transfer switch.
- Set the AUTO/OFF/MANUAL switch to AUTO.
- Disconnect utility power before the transfer switch.
 - Engine should start, transfer to load.
 - Run at least 15 minutes on generator power. Make certain all 3-phase loads are functioning correctly (correct phase rotation).
- Reconnect Utility power
 - Transfer switch will transfer back to Utility and engine will shut down within the given time parameters set up for the specific transfer switch and controller.
- Install all covers, access plates and door panels.
- Put the Owners Manual in a safe and accessible place.
- Make certain the AUTO/OFF/MANUAL switch is in the AUTO position.

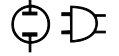
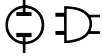

GENERATOR CONTROL AND OPERATION

Refer to the appropriate control panel operator's manual for this unit.

OPERATING UNIT WITH MANUAL TRANSFER SWITCH

If the generator was installed in conjunction with a transfer switch capable of manual operation only, the following procedure applies. A manually operated transfer switch is one that will not provide automatic start-up and does not include an intelligence circuit.

◆ ENGINE START-UP AND TRANSFER

For additional information, refer to the applicable control panel manual for this unit, as well as any literature pertaining to the specific transfer switch.



⚠ The Maintenance Disconnect Switch and the AUTO/OFF/MANUAL switches (if so equipped) must be set properly, or the generator will crank and start as soon as the utility power to the transfer switch is turned off. Refer to applicable control panel and transfer switch manuals for more information.

⚠ Do not proceed until certain that utility source voltage is available to the transfer switch and the transfer switch main contacts are set to UTILITY.

⚠ Do not attempt manual operation until all power supplies to the transfer switch have been positively turned off, or extremely dangerous - possibly lethal - electrical shock will result.

⚠ Transfer switch enclosure doors should be kept closed and locked. Only authorized personnel should be allowed access to the transfer switch interior. Extremely high and dangerous voltages are present in the transfer switch.

In order to transfer load from the utility source to the generator, follow these directions:

- Turn OFF or disconnect the utility power circuit to the transfer switch, using the means provided (such as the utility source main line circuit breaker).
- Set the transfer handle to its UTILITY (NORMAL) position with load circuits connected to the utility power supply.
- Set the standby generator's main line circuit breaker to its OFF (or OPEN) position.
- Start the generator.



⚠ Do not crank the engine continuously for longer than 30 seconds, or the heat may damage the starter motor.

- Let engine stabilize and warm up.
- Check all applicable instrument and gauge readings. When certain that all readings are correct, move the transfer switch manual handle to its STANDBY (GENERATOR) position, i.e., load circuits supplied by the generator.
- Set the standby generator's main line circuit breaker to its ON (or CLOSED) position.
- Load circuits are now powered by the standby generator.

◆ RETRANSFER AND SHUTDOWN

For additional information, refer to the applicable control panel manual for this unit, as well as any literature pertaining to the specific transfer switch.

To transfer the load back to the utility power source and shut down the generator, follow these directions:

- Set the standby generator's main line circuit breaker to its OFF (or OPEN) position.
- Manually move the transfer switch handle to its UTILITY (NORMAL) position, i.e., load circuits connected to the utility.
- Turn ON the utility power supply to the transfer switch, using the means provided (such as the utility power source main line circuit breaker).
- Let the generator run at no-load for a few minutes to stabilize internal temperatures.
- Shut down the generator.

OPERATING UNIT WITH AUTOMATIC TRANSFER SWITCH

If the generator has been installed with an automatic transfer switch, such as an RTS, HTS, or GTS-type transfer switch, the engine may be started and stopped automatically or manually.

NOTE:

Refer to the applicable manual for your transfer switch and to "Transfer Switch Start Signal Connections". In addition, please note the dangers under "Engine Start-up and Transfer."



MAINTENANCE PERFORMED BY SERVICE FACILITIES

—▲ WARNING ▲—

▲ Before working on the generator, ensure the following:

- The **AUTO/OFF/MANUAL** switch is in the **OFF** position.
- The **15A** fuse has been removed from the control box.
- The **120VAC** supply to the battery charger is switched **OFF**.

◆ EVERY THREE MONTHS

1. Check battery condition.
2. Inspect and test fuel system.
3. Check transfer switch.
4. Inspect exhaust system.
5. Check engine ignition system.
6. Check fan belts.

◆ ONCE EVERY SIX MONTHS

1. Test Engine Safety Devices (low oil pressure, low coolant level, high coolant temperature).

◆ ONCE ANNUALLY

1. Test engine governor; adjust or repair, if needed.
2. Clean, inspect generator.
3. Flush cooling system.

◆ FIRST 30 OPERATING HOURS

1. Change engine "break-in" oil and filter.

◆ FIRST 100 OPERATING HOURS

1. Change engine oil and oil filter. After initial change, service engine oil and filter at 100 operating hours or six months, whichever comes first.
2. Retorque cylinder head.
3. Retorque intake and exhaust manifold.

◆ EVERY 500 OPERATING HOURS

1. Service air cleaner.
2. Check starter.
3. Check engine DC alternator.

◆ EVERY 800 OPERATING HOURS

1. Retorque cylinder head.
2. Retorque intake and exhaust manifold.
3. Check engine compression.
4. Check valve clearance.

COOLING SYSTEM

Air intake and outlet openings in the generator compartment must be open and unobstructed for continued proper operation. This includes such obstructions as high grass, weeds, brush, leaves and snow.

Without sufficient cooling and ventilating air flow, the engine/generator quickly overheats, which causes it to shut down. (See the installation diagram.)

—▲ WARNING ▲—

▲ The exhaust system parts from this product get extremely hot and remains hot after shutdown. High grass, weeds, brush, leaves, etc. must remain clear of the exhaust. Such materials may ignite and burn from the heat of the exhaust system.

OVERLOAD PROTECTION FOR ENGINE DC ELECTRICAL SYSTEM

Engine cranking, start up and running are controlled by a solid state Engine Controller circuit board. Battery voltage is delivered to that circuit board via a 15 amp fuse. These overcurrent protection devices will open if the circuit is overloaded.

—▲ CAUTION ▲—

▲ If a circuit breaker opens or a fuse element melts, find the cause of the overload before resetting the circuit breaker or replacing the fuse.

CHECKING FLUID LEVELS

◆ CHECK ENGINE OIL

Check engine crankcase oil level (Figure 10.1) at least every 20 hours of operation, or prior to use.

Figure 10.1 - Oil Dipstick and Oil Fill Cap

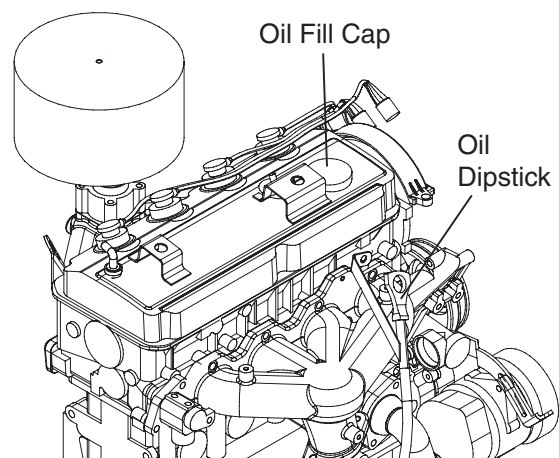



Standby Generator Sets Maintenance



- Remove oil dipstick and wipe dry with a clean, lint-free cloth.
- Install oil dipstick, then remove again.
- Oil should be between FULL and ADD marks.
- If oil level is below the dipstick ADD mark, remove oil fill cap-. Add the recommended oil to bring oil level up to the FULL mark. DO NOT FILL ABOVE THE "FULL" MARK. See "Engine Oil Recommendations" for recommended oils.

◆ BATTERY FLUID

Check battery electrolyte fluid based on the Maintenance Schedule. Fluid should cover separators in all battery cells. If fluid level is low, add distilled water to cover tops of separators. DO NOT USE TAP WATER IN BATTERY.

◆ ENGINE COOLANT

Check coolant level in coolant recovery bottle. See Specifications.

- Add recommended coolant mixture as necessary.
- Periodically remove radiator pressure cap (only when engine has cooled down) to make sure the coolant recovery system is functioning properly. Coolant should be at bottom of radiator filler neck. If coolant level is low, inspect gasket in radiator pressure cap. Replace cap, if necessary. To have pressure cap tested, contact a Service Dealer. Inspect cooling system and coolant recovery system for leaks.

MAINTENANCE OWNER/ OPERATOR CAN PERFORM

◆ CHECK ENGINE OIL LEVEL

Refer to "Checking Fluid Levels".

◆ CHECK BATTERY

- See "Checking Fluid Levels".
- Check battery cables for condition, tightness, corrosion or damage. Clean, tighten or replace as necessary.

◆ EXERCISE SYSTEM

Start the generator engine at least once every seven days and let it run at least 20 minutes. For more detailed exercise information, see the respective sections in the Control Panel Technical Manual that is supplied with the unit.

◆ INSPECT COOLING SYSTEM

- Inspect engine cooling system. See "Maintenance Schedule".
- Check hoses for damage, deterioration, leaks, etc. Correct any discrepancies found.
- Check hose clamps for tightness.

◆ CHECK ENGINE COOLANT LEVEL

See "Checking Fluid Levels".

◆ PERFORM VISUAL INSPECTION

Complete a thorough visual inspection of the entire engine-generator monthly. Look for obvious damage, loose, missing or corroded nuts, bolts and other fasteners. Look for fuel, oil or coolant leaks.

◆ INSPECT EXHAUST SYSTEM

Inspect the exhaust system at least once every three months. Check all exhaust system pipes, mufflers, clamps, etc. for condition, tightness, leaks, security, damage.

◆ CHECK FAN BELT

- Inspect fan belts every three months. Replace any damaged, deteriorated, worn or otherwise defective belt.
- Check fan belt tension. Thumb pressure, exerted midway between pulleys, should deflect about 3/8 to 5/8 of an inch. Adjust belt tension as required.

◆ INSPECT ENGINE GOVERNOR

Visually inspect electronic governor.

—▲ **DANGER** ▲—

- ▲ Do not attempt to adjust the governor. Only qualified service facilities should adjust the governor. Excessively high operating speeds are dangerous and increase the risk of personal injury. Low speeds impose a heavy load on the engine when adequate engine power is not available and may shorten engine life. Correct rated frequency and voltage are supplied only at the proper governed speed. Some connected electrical load devices may be damaged by incorrect frequency and/or voltage. Only qualified service technicians should adjust the governed speed.

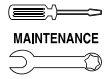

◆ CHANGING ENGINE OIL

Refer to maintenance performed by service facilities for engine oil and filter change frequencies.

Drain the oil while the engine is still warm from running. This means warm up the engine, shut it down and drain immediately as follows:

1. Remove OIL DRAIN HOSE from its retaining clip.
2. Loosen and remove OIL DRAIN HOSE CAP. Drain oil completely into suitable container.
3. When all oil has drained, install and tighten OIL DRAIN HOSE CAP, and re-install into its retaining clip.
4. Turn OIL FILTER (Figure 10.2) counterclockwise and remove. Properly dispose of old filter.

Figure 10.2 – Oil Filter

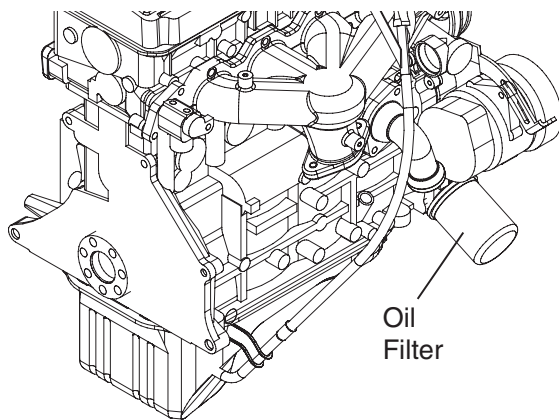

5. Apply light coating of new engine oil to seal of new oil filter. Install FILTER and tighten by hand only. DO NOT OVER TIGHTEN.
6. Remove OIL FILL CAP. Add recommended oil (see SPECIFICATIONS). DO NOT FILL ABOVE THE DIPSTICK "FULL" MARK. Crankcase oil capacity is 4.0 U.S. quarts (3.8 liters).



⚠ **After refilling the crankcase with oil, always check oil level on dipstick. NEVER OPERATE ENGINE WITH OIL BELOW THE DIPSTICK "ADD" MARK.**

7. Start engine and check for oil leaks.

◆ CHANGING THE ENGINE AIR CLEANER

To replace the engine air cleaner, remove the air cleaner cover and replace the air filter making sure it is positioned properly before reattaching the cover (Figure 10.3).

See the "Service Schedule," for air cleaner maintenance.

Figure 10.3 – Engine Air Cleaner

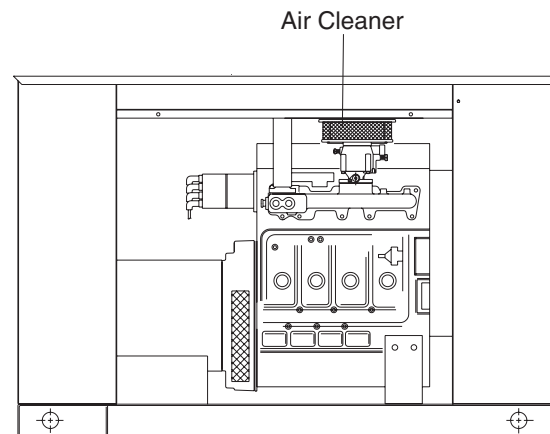

(Doors Removed for Clarity)

◆ SPARK PLUGS

Reset the spark plug gap or replace the spark plugs as necessary (Figure 10.4).

1. Clean the area around the base of the spark plugs to keep dirt and debris out of the engine. Clean by scraping or washing using a wire brush and commercial solvent. Do not blast the spark plugs to clean.
2. Remove the spark plugs and check the condition. Replace the spark plugs if worn or if reuse is questionable. See the "Service Schedule" section for recommended inspection.
3. Check the spark plug gap using a wire feeler gauge. Adjust the gap to 1.07-1.17 mm (0.042-0.046 inch) by carefully bending the ground electrode (Figure 10.4).

Figure 10.4 – Setting the Spark Plug Gap

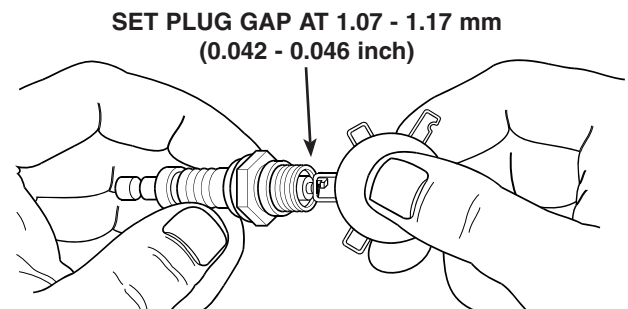

◆ COOLANT CHANGE

Every year, have a service facility drain, flush and refill the cooling system. See "Specifications" for cooling system recommendations.



MISCELLANEOUS MAINTENANCE

◆ CLEANING THE GENERATOR

Keep the generator as clean and as dry as possible. Dirt and moisture that accumulates on internal generator windings have an adverse effect on insulation resistance.

Periodically clean generator exterior surfaces. A soft brush may be used to loosen caked on dirt. Use a vacuum system or dry, low pressure air to remove any accumulations of dirt. The generator is housed inside an all-weather enclosure, clean the enclosure with a soft, damp cloth or sponge and water.

Once each year have the generator cleaned and inspected by a Service Dealer. That dealer will use dry, low pressure air to clean internal windings. Parts inside the control console should be cleaned and inspected at this time as well.

Finally, have the insulation resistance of stator and rotor windings checked. If insulation resistances are excessively low, the generator may require drying.

◆ BATTERY

All lead-acid storage batteries discharge when not in use. Refer to specific instructions and warnings that accompany the battery. If such information is not available, observe the following precautions when handling a battery:

- DO NOT use jumper cables and a booster battery to crank or start the generator engine.
- DO NOT recharge a weak battery while it is installed in the generator. Remove battery from generator and recharge in a well-ventilated area, away from fuel vapors, sparks, heat or flames.
- Battery electrolyte fluid is an extremely caustic sulfuric solution that can cause severe burns. DO NOT permit fluid to contact eyes, skin, clothing, painted surfaces, wiring insulation, etc. If any battery fluid is spilled, flush the affected area with clear water immediately.
- Always wear safety glasses, rubber apron and gloves when handling a battery.
- Batteries give off explosive hydrogen gas while charging. The gas can form an explosive mixture around the battery for several hours after charging. Any spark, heat or flames can ignite the gas and cause an explosion which can shatter the battery, causing blindness or other serious injury.

◆ BATTERY MAINTENANCE

The battery should be inspected per the "Scheduled Maintenance" section. The following procedure should be followed for inspection:

1. Inspect the battery posts and cables for tightness and corrosion. Tighten and clean as necessary.

2. Check the battery fluid level of unsealed batteries and, if necessary, fill with DISTILLED WATER ONLY. DO NOT USE TAP WATER IN BATTERIES.
3. Have the state of charge and condition checked. This should be done with an automotive-type battery hydrometer.



 **Storage batteries give off explosive hydrogen gas. This gas can form an explosive mixture around the battery for several hours after charging. The slightest spark can ignite the gas and cause an explosion. Such an explosion can shatter the battery and cause blindness or other injury. Any area that houses a storage battery must be properly ventilated. Do not allow smoking, open flame, sparks or any spark producing tools or equipment near the battery.**

 **Battery electrolyte fluid is an extremely corrosive sulfuric acid solution that can cause severe burns. Do not permit fluid to contact eyes, skin, clothing, painted surfaces, etc. Wear protective goggles, protective clothing and gloves when handling a battery. If fluid is spilled, flush the affected area immediately with clear water.**

 **Do not use any jumper cables or booster battery to crank and start the generator engine. If the battery has completely discharged, remove it from the generator for recharging.**



 **Be sure the AUTO/OFF/MANUAL switch is set to the OFF position, before connecting the battery cables. If the switch is set to AUTO or MANUAL, the generator can crank and start as soon as the battery cables are connected.**

 **Be sure the 120VAC power supply to the battery is turned OFF, or sparking may occur at the battery posts as the cables are attached and cause an explosion.**

◆ BATTERY REPLACEMENT

NOTE:

Unit DOES NOT include battery.

When supplying or replacing the battery, the recommended number and type of battery is listed in the Specifications Section.

NOTE:

The BCI number should be located directly on the battery.

REPAIR PARTS

The later portion of this manual consists of exploded views, parts lists and electrical data pertaining to this generator set.

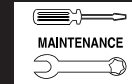

SERVICE SCHEDULE

30 KW - 150 KW STANDBY GAS ENGINE DRIVEN GENERATOR SETS

The following is a recommended maintenance schedule for standby gas engine driven generator sets from 30kW to 150 kW in size. The established intervals in the schedule are the maximum recommended when the unit is used in an average service application. They will need to be decreased (performed more frequently) if the unit is used in a severe application. Use calendar time, from the previous maintenance interval to determine the next required maintenance interval.

Service Maintenance Interval Information:

The various service maintenance intervals are designated by interval numbers as follows:

- 1 An early inspection of the generator set to insure it is ready to operate when required and to identify any potential problem areas.

This inspection may be performed by the end user providing the following safety steps are taken to prevent the engine from starting automatically without warning:

To prevent injury, perform the following steps in the order indicated before starting any maintenance:

- **Disable the generator set from starting and/or connecting to the load by setting the control panel Auto/Off/Manual switch to the "OFF" position.**
- **Remove the 15 amp control panel fuse.**
- **Turn off the battery charger.**
- **Remove the negative battery cable.**

The battery charger must be turned off BEFORE removing the battery cable to prevent an over current condition from burning out sensitive control panel components and circuits.

Following all maintenance, reverse these steps to insure the unit is returned to standby setup for normal operation when required.

- 2 A wear-in service inspection of the generator set to insure it is ready to operate and carry the load when required, and to identify any potential problem areas.

*Performed **ONLY ONCE** following the first three months or the first 30 hours of operation after purchase of the unit.*

This inspection contains some maintenance tasks which require special tools, equipment, and/or knowledge to accomplish and should be performed only by an Authorized Service Dealer.

- 3 An operational inspection of the generator set to insure it is ready to operate and carry the load when required, and to identify any potential problem areas.

Performed semi-annually or following each 50 hours of operation of the unit.

This inspection contains some maintenance tasks which require special tools, equipment, and/or knowledge to accomplish and should be performed only by an Authorized Service Dealer.

- 4 A mid-level inspection of the generator set to insure it is ready to operate and carry the load when required, and to identify any potential problem areas.

Performed annually or following each 100 hours of operation of the unit.

This inspection contains some maintenance tasks which require special tools, equipment, and/or knowledge to accomplish and should be performed only by an Authorized Service Dealer.

- 5 A comprehensive inspection of the generator set to insure it is properly serviced and ready to operate and carry the load when required, and to identify any potential problem areas.

Performed annually or following each 250 hours of operation of the unit.

This inspection contains some maintenance tasks which require special tools, equipment, and/or knowledge to accomplish and should be performed only by an Authorized Service Dealer.



Standby Generator Sets Service Schedule



Maintenance Tasks	Level 1	Task Comp. (Date-Initials)	Level 2	Task Comp. (Date-Initials)	Level 3	Task Comp. (Date-Initials)	Level 4	Task Comp. (Date-Initials)	Level5	Task Comp. (Date-Initials)
	Recommended to be done monthly/ 10 hrs.		Required to be done 3 months/ Break-in 30 hrs.		Required to be done Semi-annually/ 50 hrs.		Required to be done Annually/ 100 hrs.		Required to be done Bi-annually/ 250 hrs.	
1. Disable the unit from operating per the first page warning.	○		○		○		○		○	
2. Check the engine oil level. Adjust as necessary.	○		○		○		○		○	
3. Check the engine coolant level. Adjust as necessary.	○		○		○		○		○	
4. Check the engine coolant thermal protection level. Correct as necessary.							○		○	
5. Check the natural gas delivery system for leaks and correct pressure on gas engine driven units. Tighten connections as necessary.	○		○		○		○		○	
6. Check the air inlets and outlets for debris. Clean as necessary.	○		○		○		○		○	
7. Check the battery electrolyte level and specific gravity if accessible. Adjust as necessary.	○		○		○		○		○	
8. Check the battery posts, cables, and charger for loose connections, corrosion, and proper operation. Correct as necessary.	○		○		○		○		○	
9. Check the unit wiring for loose connections, corrosion, and damage. Correct as necessary.	○		○		○		○		○	



Standby Generator Sets Service Schedule



Maintenance Tasks	Level 1	Task Comp. (Date-Initials)	Level 2	Task Comp. (Date-Initials)	Level 3	Task Comp. (Date-Initials)	Level 4	Task Comp. (Date-Initials)	Level 5	Task Comp. (Date-Initials)
	Recommended to be done monthly/ 10 hrs.		Required to be done 3 months/ Break-in 30 hrs.		Required to be done Semi-annually/ 50 hrs.		Required to be done Annually/ 100 hrs.		Required to be done Bi-annually/ 250 hrs.	
10. Check the engine accessory drive belts and fan coupling device if equipped for correct tension, wear, weather cracking, and damage. Replace as necessary.			○				○		○	
11. Check the engine valve clearance/lash. Adjust as necessary.							○		○	
12. Visually inspect the unit looking for leaks, wear or damage, loose connections or components, and corrosion. Correct as necessary.							○		○	
13. Test the engine and transfer switch safety devices. Correct and/or adjust as necessary.	○		○		○		○		○	
14. Initiate an automatic start and transfer of the unit to site load and exercise it for at least 1 hour looking for leaks, loose connections or components, and abnormal operating conditions. Correct as necessary.							○		○	
15. Replace the engine accessory drive belts.									○	
16. Check gearbox oil level (if equipped).	○		○		○		○		○	
17. Change gearbox oil (if equipped).									○	



Standby Generator Sets Service Schedule



Maintenance Tasks	Level 1	Task Comp. (Date-Initials)	Level 2	Task Comp. (Date-Initials)	Level 3	Task Comp. (Date-Initials)	Level 4	Task Comp. (Date-Initials)	Level 5	Task Comp. (Date-Initials)
	Recommended to be done monthly/ 10 hrs.		Required to be done 3 months/ Break-in 30 hrs.		Required to be done Semi-annually/ 50 hrs.		Required to be done Annually/ 100 hrs.		Required to be done Bi-annually/ 250 hrs.	
18. Start and exercise the unit at full rated load (use a load bank if the site load is not enough) for at least 2 hours looking for leaks, loose connections or components, and abnormal operating conditions. Correct as necessary.									●	
19. Perform an engine oil analysis (send a sample to a lab for results). Change the engine oil and filters if the analysis results indicate this is required.							●			
20. Change the engine oil.			●				●		●	
21. Replace the engine oil filter(s).			●				●		●	
22. Replace engine spark plugs. Clean and re-gap or replace as necessary.							●			
23. Replace the engine air filter(s).									●	
24. Perform a 5 minute no-load operational run of the unit looking for any post service problems.			●						●	
25. Return the unit to standby setup for operation when required.	●		●		●		●		●	



TROUBLESHOOTING GUIDE

PROBLEM	CAUSE	CORRECTION
Engine won't crank.	<ol style="list-style-type: none"> 15 amp fuse blown. Loose or corroded or defective battery cables. Defective starter contactor. Defective starter motor. Dead or Defective Battery. 5 amp fuse blown. 	<ol style="list-style-type: none"> Replace fuse. Tighten, clean or replace battery cables as necessary. Replace contactor.* Replace starter motor.* Remove, change or replace battery. Replace fuse.*
Engine cranks but won't start	<ol style="list-style-type: none"> Out of fuel. Fuel solenoid (FS) is defective Open Wire #14A from Engine Control circuit board. Spark plugs defective. Door on tank not closed. 	<ol style="list-style-type: none"> Replenish fuel. Replace solenoid.* Reconnect wire. Clean, regap or replace plugs. Close door on tank.
Engine starts hard, runs rough.	<ol style="list-style-type: none"> Flame arrestor (air cleaner) plugged or damaged. Plugged fuel line. Defective spark plugs. Fuel pressure incorrect. 	<ol style="list-style-type: none"> Clean or replace as needed. Unclog fuel line. Clean, regap or replace plugs. Confirm fuel pressure to regulator is as recommended in SPECIFICATIONS.
Engine starts then shuts down.	<ol style="list-style-type: none"> Engine oil level is low. Engine is overheated. Defective Low Oil Pressure Switch Defective Coolant Temperature Switch Defective Control Module circuit board. Coolant Level is Low. Defective Low Coolant Level Switch 	<ol style="list-style-type: none"> Check oil and add oil as needed. Check cooling system for leaks. Replace switch.* Replace switch.* Replace board.* Repair leak - Add coolant. Replace Switch.*
AUTO/OFF/MANUAL Switch at OFF, engine continues to run	<ol style="list-style-type: none"> Defective AUTO/OFF/MANUAL switch Open/disconnected wire #15A between AUTO/OFF/MANUAL switch and Control Module circuit board. Defective Control Module circuit board 	<ol style="list-style-type: none"> Replace switch.* Reconnect/close wire. Replace board.*
No AC output from generator.	<ol style="list-style-type: none"> Check main line circuit breaker. Check circuit breaker & fuses. Transfer switch set to NORMAL position Generator internal failure. Thermal circuit breaker open. 	<ol style="list-style-type: none"> Reset to ON or CLOSED. Reset and replace, if necessary. Set to GENERATOR position. * Auto-reset - Wait 5 min. and attempt restart.

***Contact the nearest Authorized Dealer for assistance.**

GROUP A

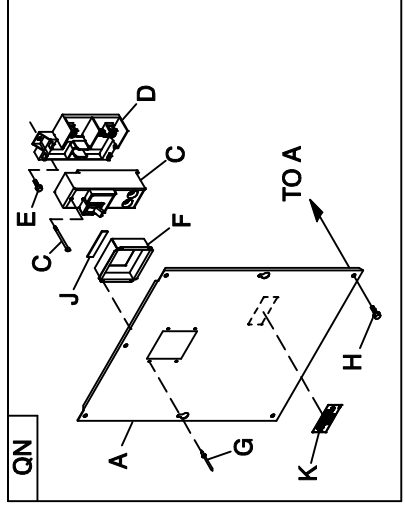
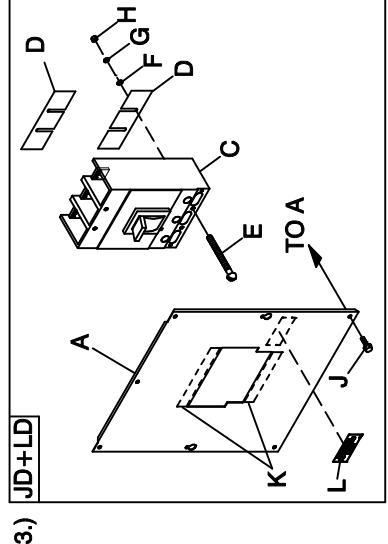
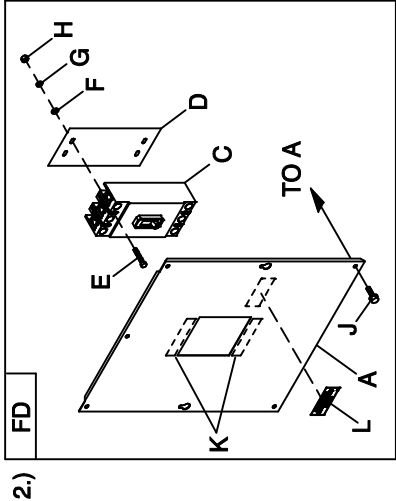
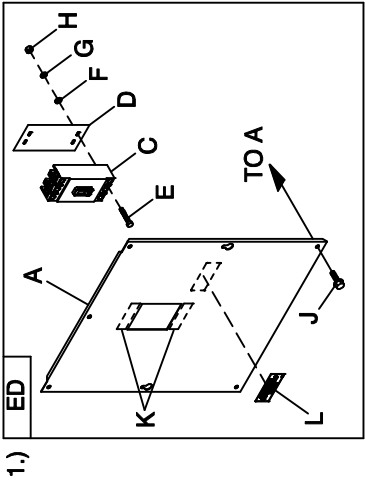
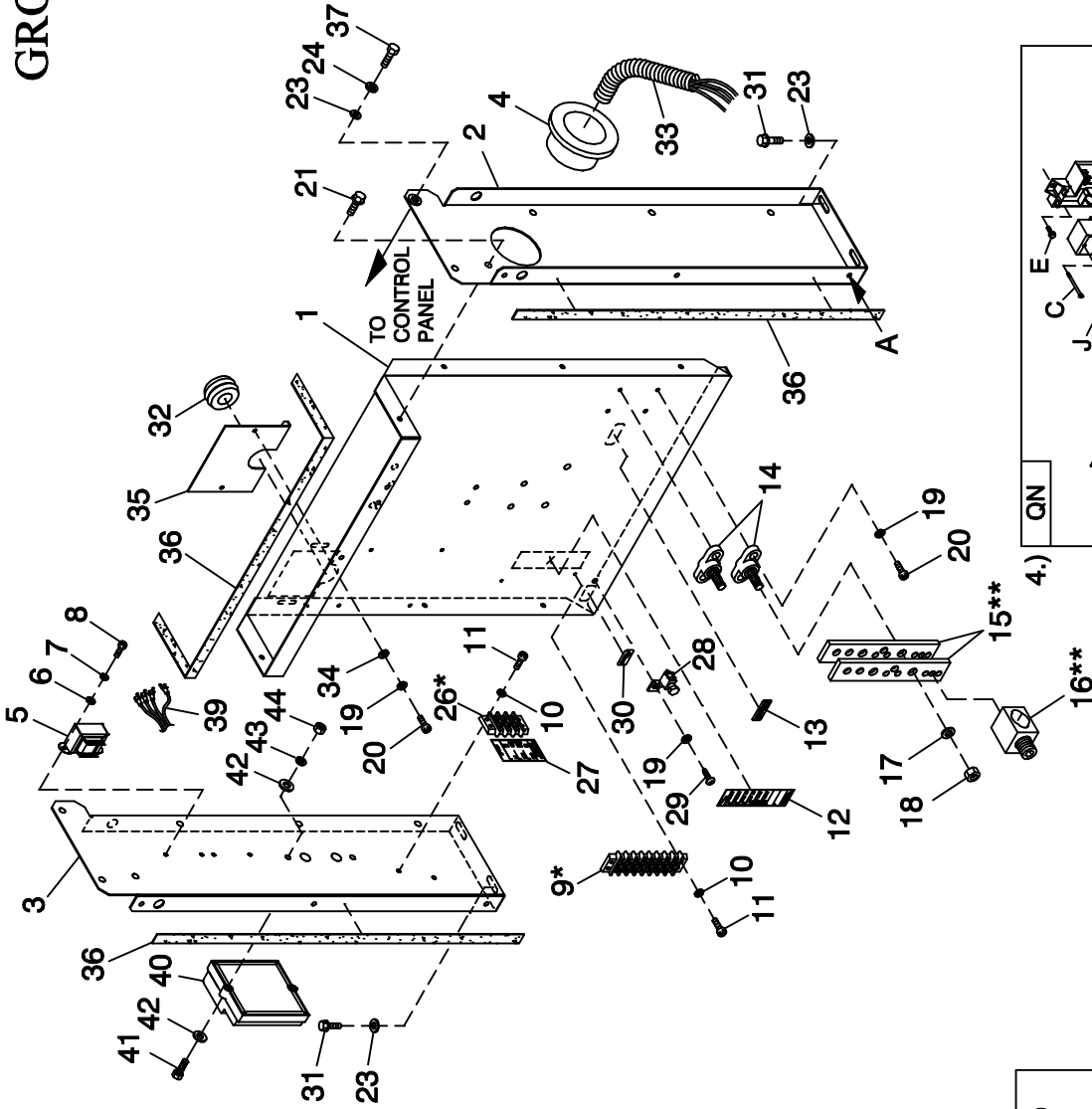

EXPLODED VIEW:
CPL C2 & C4 FLEX HSB
DRAWING #: 0F3391D

EXPLODED VIEW: CPL C2 & C4 FLEX HSB
DRAWING #: 0F3391D

GROUP A

APPLICABLE TO:

ITEM	PART #	QTY.	DESCRIPTION
1	0F3137	1	PAN CB CONN BOX
2	0F3188	1	STAND RH CONTROL
3	0F3189	1	STAND LH CONTROL
4	023484N	1	BUSHING SNAP SB-2.5-31
5	0F6366B	1	XFMR DUAL 120V/16V (FOR 120/240V & 277/480V UNITS)
	0F6366A	1	XFMR DUAL 104V/16V (FOR 120/208V UNITS)
6	043180	2	WASHER FLAT M4
7	022264	2	WASHER LOCK #8-M4
8	0C3990	2	SCREW PHTT M4-0.7 X 10 ZYC
(1) 9	057701	REF	BLOCK TERM 20A 8 X 6 X 1100V
10	022155	4	WASHER LOCK #6
11	0C2428	4	SCREW PHTT #6-32 X 1/2 ZYC
12	0F3824	1	DECAL UTIL SENSE/CUST CONN
13	0A9457	1	DECAL NEUTRAL
14	057073	2	JUNCTION BLOCK 3/8-16
(2) 15	0D5466	REF	BUS BAR NEUTRAL BLOCK 390
(2) 16	0A7822	REF	LUG SLDLSS 600/250-1/0 X 1/4-28
17	022237	2	WASHER LOCK 3/8
18	022241	2	NUT HEX 3/8-16 STEEL
19	049226	4	WASHER LOCK M5
20	0C2266	4	SCREW PHTT M5-0.8 X 16 ZYC
21	0C2454	8	SCREW THF M6-1 X 16 N WA Z/JS
23	022473	8	WASHER FLAT 1/4-M6 ZINC
24	022097	4	WASHER LOCK M6-1/4
(1) 26	0D4698	REF	BLOCK TERM 20A 6 X 3 X 1100V
27	0F4464	1	DECAL CUST CONN 120V UTILITY
28	025433	1	LUG SLDLSS #6-14 X 13/64 CU
29	024469	1	SCREW HHTT #10-32 X 3/8 CZ
30	067210A	1	DECAL GROUND LUG
31	0D6029	4	SCREW HHTT M6-1.0 X 16 ZYC
32	081008	1	GROMMET 1.25 X .25 X .75
33	077043J	1	CONDUIT FLEX 2.0" ID (36" LG)
34	051713	2	WASHER FLAT M5
35	0F6156	1	PLATE WIRE SNGL GALV
36	029289	1	TAPE ELEC 1/2 FOAM (AS REQ'D)
37	047411	4	SCREW HHC M6-1.0 X 16 G8.8
(3) 39	0G0770	1	HARNES, TRANSFORMER ADAPTER
(4) 40	0G5952	1	ASSY PCB IGN MOD 4.2L
(4) 41	036943	2	SCREW PPHM #10/32 X 2
(4) 42	023897	4	WASHER FLAT #10 ZINC
(4) 43	022152	2	WASHER LOCK #10
(4) 44	022158	2	NUT HEX #10-32 STEEL
1)			UL CIRCUIT BREAKER (ED)
A	0F3328	1	COVER ED CB SHORT STND
C	0D5552	1	CB 0050A 3P 480V S ED4 LL
	0D5554	-	CB 0070A 3P 480V S ED4 LL
	0D5556	-	CB 0090A 3P 480V S ED4 LL
	0D9693	-	CB 0125A 3P 480V S ED4 LL
D	0F0492	1	INSULATOR CB S (ED-3P)
E	048927	4	SCREW RHM #10-32 X 4-1/2
F	023897	4	WASHER FLAT #10 ZINC
G	022152	4	WASHER LOCK #10
H	022158	4	NUT HEX #10-32 STEEL
J	0C2454	7	SCREW THF M6-1 X 16 N WA Z/JS
K	029289	1	TAPE ELEC 1/2 FOAM (AS REQ'D)
L	0F1733	1	DECAL CUSTOMER CONNECT INSIDE
2)			UL CIRCUIT BREAKER (FD)
A	0F3138	1	COVER CB CONN BOX
C	0D5572	1	CB 0150A 3P 600V S FD6 LL
	0D5573	-	CB 0175A 3P 600V S FD6 LL
	0D5574	-	CB 0200A 3P 600V S FD6 LL
	0D5575	-	CB 0225A 3P 600V S FD6 LL
	0D5576	-	CB 0250A 3P 600V S FD6 LL
D	0F0199	1	INSULATOR CB FD FRAME 30MIL
E	081320	4	SCREW SHC 1/4-20 X 4.5 G8.8 NZ
F	022473	4	WASHER FLAT 1/4-M6 ZINC
G	022097	4	WASHER LOCK M6-1/4
H	022127	4	NUT HEX 1/4-20 STEEL
J	0C2454	7	SCREW THF M6-1 X 16 N WA Z/JS
K	029289	1	TAPE ELEC 1/2 FOAM (AS REQ'D)
L	0F1733	1	DECAL CUSTOMER CONNECT INSIDE

ITEM	PART #	QTY.	DESCRIPTION
3)			UL CIRCUIT BREAKER (JD+LD)
A	0F3329	1	COVER JD/LD CB SHRT STAND
C	0D5577	1	CB 0300A 3P 600V S JD6 LL
D	0F2353	2	INSULATOR CIRCUIT BR. JD/LD
E	022770	4	SCREW RHM 1/4-20 X 3
F	022473	4	WASHER FLAT 1/4-M6 ZINC
G	022097	4	WASHER LOCK M6-1/4
H	022127	4	NUT HEX 1/4-20 STEEL
J	0C2454	7	SCREW THF M6-1 X 16 N WA Z/JS
K	029289	1	TAPE ELEC 1/2 FOAM (AS REQ'D)
L	0F1733	1	DECAL CUSTOMER CONNECT INSIDE
4)			UL CIRCUIT BREAKER (QN)
A	0F8135	1	COVER QN FRM CB
C	0E7283	-	CB 0150A 2P 240V S QN2 LL
	0E7284	-	CB 0175A 2P S QN2 LL 240V
D	0E3664	1	BASE, QN CIRCUIT BREAKER
E	074908	2	SCREW HHTT M5-0.8 X 10 BP
F	0F8140	1	COVER QN CB DISH
G	036261	4	RIVET POP .125 X .275 SS
H	0C2454	7	SCREW THF M6-1X16 N WA Z/JS
J	029289	1	TAPE ELEC 1/2 FOAM (AS REQ'D)
K	0F1733	1	DECAL CUSTOMER CONNECT INSIDE
			(1) ITEM INCLUDED WITH HARNESS
			(2) ITEM INCLUDED WITH 0D5464B
			(3) ITEM USED WITH EARLY MODEL 208V UNITS ONLY
			(4) ITEMS USED ON 4.2L MODELS ONLY.

GROUP A

6.) 225AF

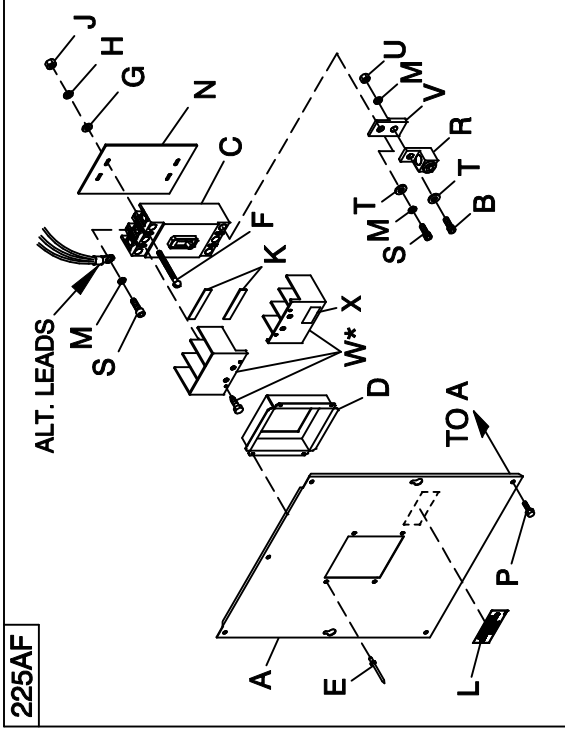

8.) OD5464B

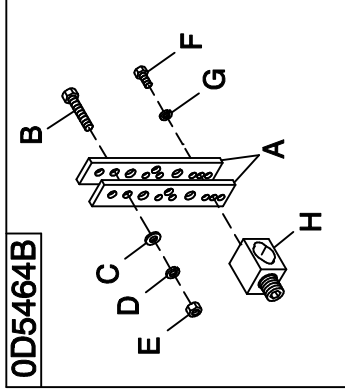

9.) BQ

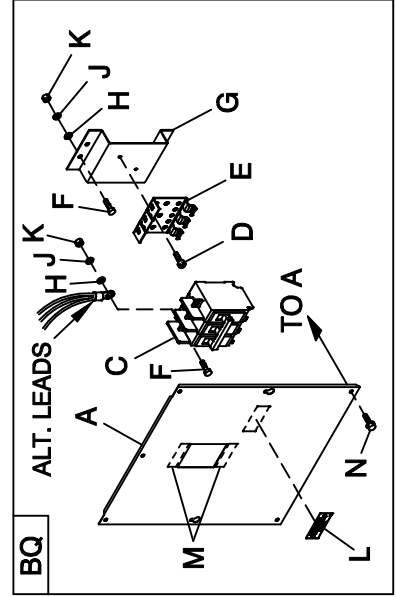

5.) QJ-2P

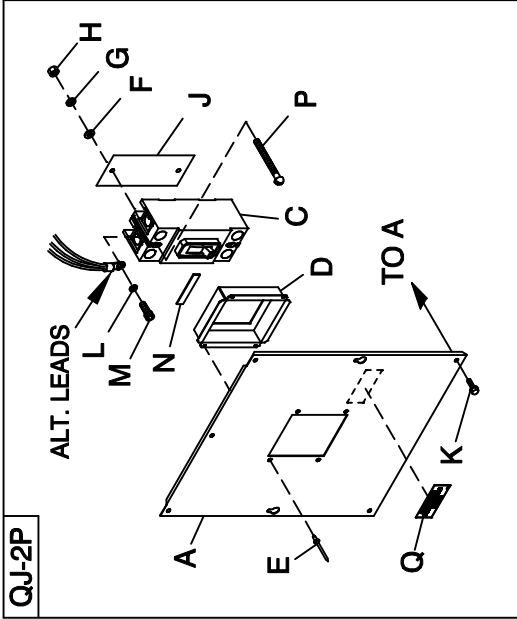

7.) 400AF

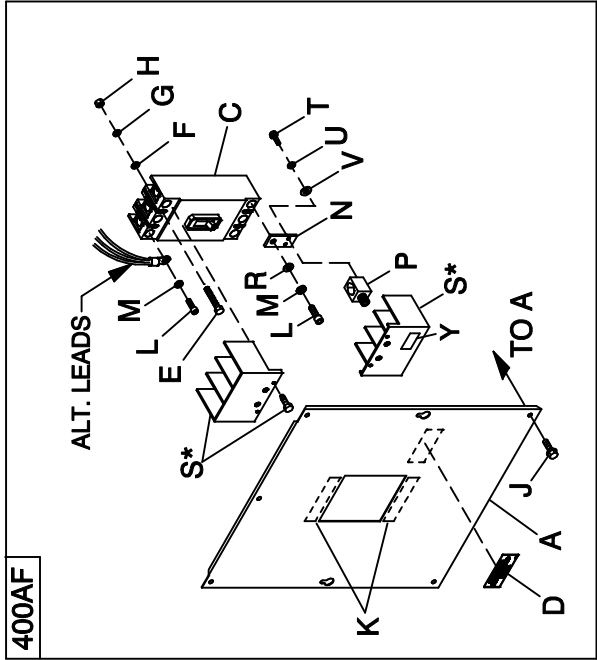

EXPLODED VIEW:
CPL C2 & C4 FLEX HSB
DRAWING #: 0F3391D

EXPLODED VIEW: CPL C2 & C4 FLEX HSB
DRAWING #: 0F3391D

GROUP A

APPLICABLE TO:

ITEM	PART #	QTY.	DESCRIPTION
5)			UL CIRCUIT BREAKER (QJ-2P)
A	0F8137	1	COVER QJ 2P FRM CB
C	0E7994	-	CB 0225A 240V 2P S QJ22
D	0F8136	1	COVER QJ 2P CB DISH
E	036261	4	RIVET POP .125 X .275 SS
F	022473	2	WASHER FLAT 1/4-M6 ZINC
G	022097	2	WASHER LOCK M6-1/4
H	022127	2	NUT HEX 1/4-20 STEEL
J	0F8139	1	INSUL CB 2P QJ
K	0C2454	7	SCREW THF M6-1 X 16 N WA Z/JS
L	022237	2	WASHER LOCK 3/8
M	048527	2	SCREW SHC 3/8-16 X 3/4 G8.8 NZ
N	029289	1	TAPE ELEC 1/2 FOAM (AS REQ'D)
P	022770	2	SCREW RHM 1/4-20 X 3
Q	0F1733	1	DECAL CUSTOMER CONNECT INSIDE
6)			UL CIRCUIT BREAKER (225AF) (2P & 3P)
A	0F4185	1	COVER CB C2-C4 (225AF)
B	058306	3	SCREW SHC M8-1.25 X 25 G12.9
C	0F4166\$	REF	CIRCUIT BREAKERS 200A FRAME (3P)
	0F4143	REF	CB 0040A 3P 480V 225AF (3P)
	0F4149	REF	CB 0150A 3P 480V G 225AF
	0F4151	REF	CB 0200A 3P 480V G 225AF
	0G5247\$	REF	CB 200A FRAME G 240V (2P)
	0G5250	REF	CB 175A 2 POLE 240V 225AF (2P)
	0G4478	REF	CB 200A 2 POLE 240V 225AF (2P)
D	0F4186	1	COVER CB DISH 225AF (3P)
	0F4186AGSOR		COVER CB DISH 225AF (2P)
E	036261	4	RIVET POP .125 X .275 SS
(2) F	053640	2/4	SCREW RHM #8-32 X 3-1/4
(2) G	038150	2/4	WASHER FLAT #8 ZINC
(2) H	022264	2/4	WASHER LOCK #8-M4
(2) J	022471	2/4	NUT HEX #8-32 STEEL
K	029289	2	TAPE ELEC 1/2 FOAM
L	0F1733	1	DECAL CUSTOMER CONNECT INSIDE
(2) M	022129	6/9	WASHER LOCK M8-5/16
N	0F8432	1	INSULATOR CB 225AF (3P)
	0F8432A	1	INSULATOR CB 225AF (2P)
P	0C2454	7	SCREW THF M6-1 X 16 N WA Z/JS
(2) R	0F8451	2/3	LUG SLDLSS 300 MCM-6 AL/CU
(2) S	049897	4/6	SCREW SHC M8-1.25 X 20 G8
(2) T	022145	4/6	WASHER FLAT 5/16-M8 ZINC
(2) U	045771	2/3	NUT HEX M8-1.25 G8 CLEAR ZINC
(2) V	0F8843	2/3	BUS BAR 200A LUG ADAPTOR
(1) W	W/CB	2	TERMINAL COVER CB
X	0G3259	1	DECAL TERMINAL SHOCK HZD BI
7)			UL CIRCUIT BREAKER (400AF)
A	0F4187	1	COVER CB C2-C4 400AF
C	0F4166\$	REF	CIRCUIT BREAKERS 400A FRAME
D	0F1733	1	DECAL CUSTOMER CONNECT INSIDE
E	042419	4	SCREW RHM 10-32 X 4
F	023897	4	WASHER FLAT #10 ZINC
G	022152	4	WASHER LOCK #10
H	022158	4	NUT HEX #10-32 STEEL
J	0C2454	7	SCREW THF M6-1 X 16 N WA Z/JS
K	029289	1	TAPE ELEC 1/2 FOAM
(2) L	052647	2/3	SCREW SHC M10-1.5 X 25 G12.9
(2) M	046526	2/3	WASHER LOCK M10
N	W/CB	3	BUS BAR CB ADAPTER 225-400 A
P	0A7822	3	LUG SLDLSS 600/250-1/0 X 1/4-28
(1) S	W/CB	2	TERM COVER CB
T	023334	6	SCREW HHC 1/4-28 X 1/2 G5
U	022097	6	WASHER LOCK M6-1/4
V	022473	6	WASHER FLAT 1/4-M6 ZINC
(2) W	W/CB	2/3	SCREW SHC M10-1.5 X 25 G12.9
(2) X	W/CB	2/3	WASHER LOCK M10
Y	0G3259	1	DECAL TERMINAL SHOCK HZD BI

ITEM	PART #	QTY.	DESCRIPTION
8)			NEUTRAL BLOCK 390 / 200-400A
A	0D5466	2	BUS BAR NEUTRAL BLOCK 390
B	039287	1	SCREW HHC M8-1.25 X 45 G8.8 FT
C	022145	1	WASHER FLAT 5/16-M8 ZINC
D	022129	1	WASHER LOCK M8-5/16
E	045771	1	NUT HEX M8-1.25 G8 YEL CHR
F	045335	2	SCREW HHC 1/4-28 X 3/4 G5
G	083896	2	WASHER LOCK 1/4-M6 SS
H	0A7822	1	LUG SLDLSS 600/250-1/0 X 1/4-28
9)			UL CIRCUIT BREAKER (BQ)
A	0G1968	1	COVER BQ CIR BREAKER CPL 3P
	0G1970	-	COVER BQ CIR BREAKER CPL 2P
C	0A2077	1	CB 0125A 2P 240V S BQ2 LL
	040532	-	CB 0100A 3P 240V S BQ3 LL
D	0C3990	2	SCREW PHTT M4-0.7 X 10 ZYC
E	0E7890	1	BRKT CB MTG BACK
	0E6002	-	MTG TRACK BQ SIEMENS CB 3P
F	022859	6	SCREW RHM #10-32 X 3/4
G	0G0008	1	BRKT BQ CB STANDOFF
H	023897	6	WASHER FLAT #10 ZINC
J	022152	6	WASHER LOCK #10
K	022158	6	NUT HEX #10-32 STEEL
L	0F1733	1	DECAL CUSTOMER CONNECT INSIDE
M	029289	1	TAPE ELEC 1/2 FOAM
N	0C2454	7	SCREW THF M6-1 X 16 N WA Z/JS

(1) HARDWARE FOR MTG. CB TERMINAL COVERS IS SUPPLIED WITH CIRCUIT BREAKERS.

(2) QTY. REQ'D FOR "2POLE / 3POLE" BREAKER

GROUP A

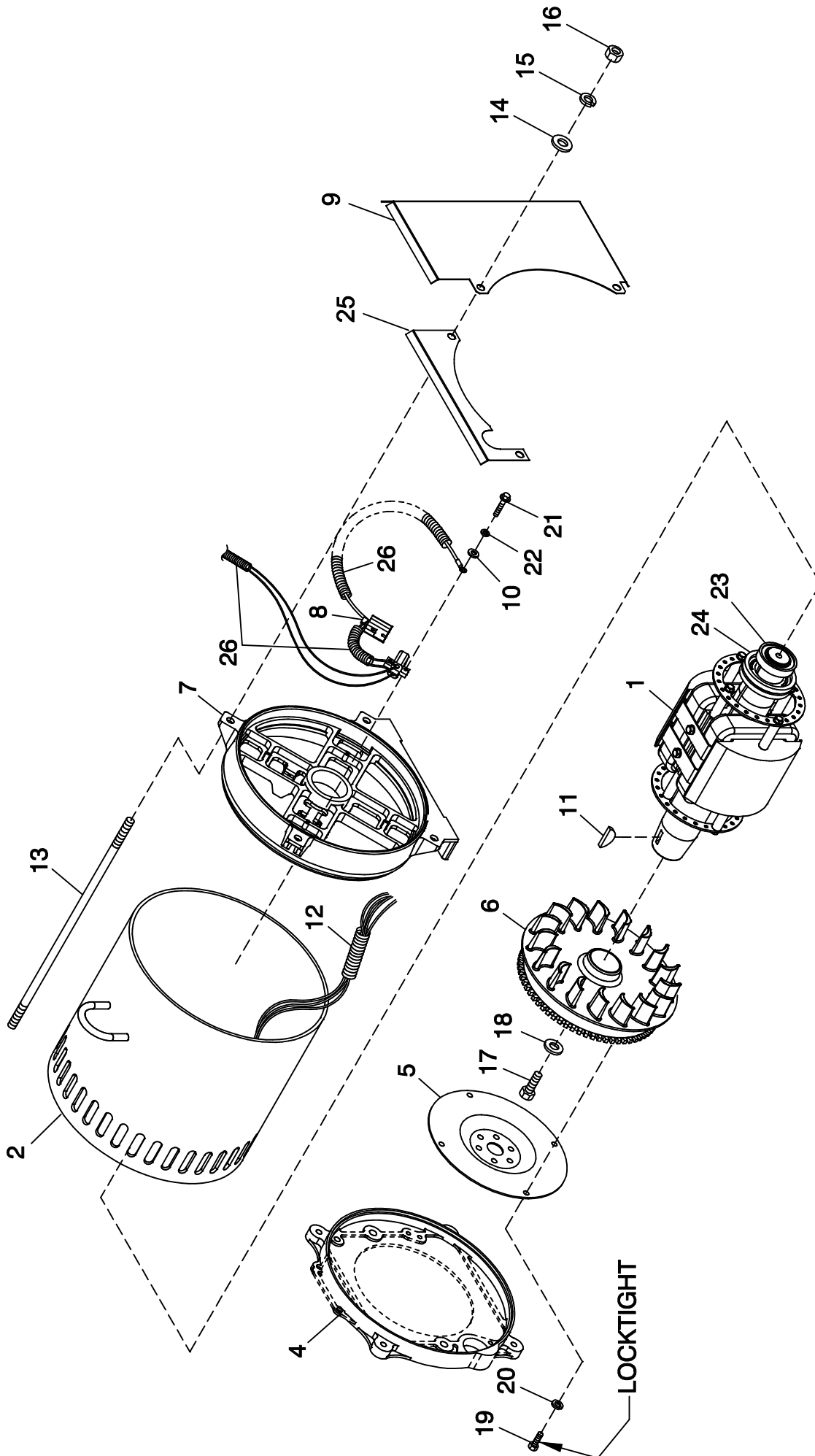

EXPLODED VIEW: CPL ALTERNATOR DIRECT EXCITATION
DRAWING #: 0F9803

GROUP A

APPLICABLE TO:

ITEM	PART #	QTY.	DESCRIPTION
1	0G0056	1	ROTOR-2390-35KD1 CPL
	0G1155	1	ROTOR-2390-35KD1 CPL (G2)
	0F9677	1	ROTOR-2390-45KD1 CPL
	0G0959	1	ROTOR-2390-45KD1 CPL (G2)
	0G2101	1	ROTOR 25KW 1PH DIRECT 390 1800
	0G1931	1	ROTOR 25KW 3PH DIRECT 390 1800
2	0G0057	1	STATOR-2390-35AD1 CPL
	0F9664	1	STATOR-390 45K 2P 1PH DIRECT
	0G0058	1	STATOR-2390-35KD1 CPL
	0G0184	1	STATOR-2309-45-KD1 CPL
	0G0059	1	STATOR-2390-35GD1 CPL
	0G0183	1	STATOR-2309-45KW 2P 3PH 208V
	0G6104	1	STR-2390--45JD1 CPL
	0G2098	1	ASSY STR 390 25AD1 CPL
	0G2100	1	ASSY STR 390 25JD3 CPL
	0G1932	1	ASSY STR 390 25GD3 CPL
	0G2099	1	ASSY STR 390 25KD3 CPL
3	0C9708	REF	INSTR HYPOT TEST (NOT SHOWN)
4	SEE ENGINE EV	REF	ENGINE ADAPTER
5	SEE ENGINE EV	REF	FLEXPLATE
6	0F5767B	1	ASSY FLYWHEEL CPL W/40MM FAN B
7	0E5706	1	REAR BEARING CARRIER 390/DRCT
8	0F7874	1	ASSY BRUSH HOLDER 390/HSB
9	0G0587	1	GUARD REAR BEARING CARRIER
10	038150	4	WASHER FLAT #8 ZINC
11	023454	1	KEY WOODRUFF #E
12	077043E	1	CONDUIT FLEX 1.0" ID (35" LG)
13	04576100BU	4	STUD M14-2.0 570 G5 ZINC
14	052646	4	WASHER FLAT M14
15	043123	4	WASHER LOCK M14
16	051779	4	NUT HEX M14-2.0 G8 YEL CHR
17	0A2601	1	SCREW HHC M16-2.0 X 45 G8.8
18	0A2602	1	WASHER FLAT .688 ID X 3.25 OD
19	0F8408	4	SCREW HHC M10-1.50 X 16 G10.9
20	046526	4	WASHER LOCK M10
21	0C3993	4	SCREW HHTT M4-0.7 X 25 BP
22	022264	4	WASHER LOCK #8-M4
23*	047248	1	BALL BEARING-45 MM
24*	070892	1	SLIP RING MACHINED
25	0G0588	1	GUARD REAR BEARING CARRIER
26	077043A	1	CONDUIT FLEX .38" ID (60")

* ROTOR REPLACEMENT PARTS

GROUP B

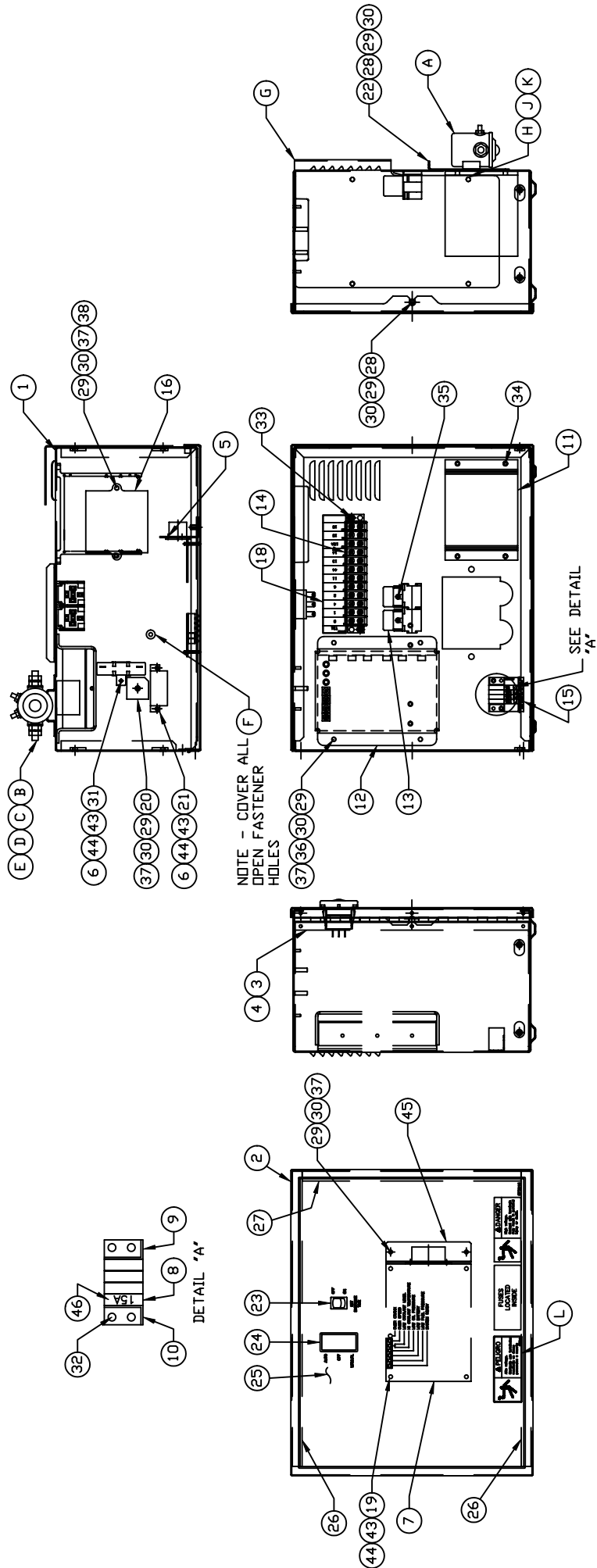

EXPLODED VIEW:
R-200 1800 RPM 2.4L
DRAWING #: 0G2283D

APPLICABLE TO:

ITEM	PART #	QTY.	DESCRIPTION
<u>COMPONENTS INCLUDED IN 0G2283D</u>			
1	0F1823A	1	ENCL HSB CONTROL PANEL
2	0F3078	1	COVER CONTROL PANEL
3	0F2606	1	HINGE CONTINUOUS H-PANEL
4	036261	6	RIVET POP .125 X .275 SS
5	0E7358	4	SCREW PPPH HI-LO #4-24 X 3/8
6	052777	3	WASHER FLAT M3
7	0G1303C	1	ASSY PCB R-200 1800 RPM 2.4L
8	0F1262	4	HOLDER FUSE WICKMANN 178.6150
9	0F1263	1	ADPTR RH SIDE WICKMAN 178.6191
10	0F1264	1	ADPTR LH SIDE WICKMAN 178.6192
11	0F1725C	1	ASSY PCB 2AMP 12V UL BATT CHGR
12	067680	1	ASSY VOLTAGE REGULATOR 60HZ
13	0E6875A	2	RELAY 12VDC C FORM W/DIODE
14	055911	1	BLOCK TERM 20A 12 X 6 X 1100V
15	0F5459	1	DECAL CPL CONTROL PANEL FUSES
16	0E3161	1	ASSY PCB BOSCH GOV DRIVER
18	0F5462	1	DECAL CPL 3.9L TB1
19	0A5062J	4	SPACER 9.5H 3.2 ID
20	029673	1	DIO BRIDGE 25A 600V
21	048467	1	CIRCT BRK 7 X 1 ETA 46-500-P
22	0F1958	1	PLATE HARNESS CLAMP
23	082573	1	SWITCH RKR DPST 125V SPD
24	0E4494	1	SWITCH RKR DPDT ON-OFF-ON
25	0F3215	1	DECAL, CONTROL HSB
26	0F6305	2	SEAL COVER 3.18 X 12.7 X 382
27	0F6305A	1	SEAL COVER 3.18 X 12.7 X 283
28	0F5886	3	SCREW HHPM M5-0.8 X 12
29	051713	12	WASHER FLAT M5
30	049226	12	WASHER LOCK M5
31	0F5752F	1	RES WW 15R 5% 25W QK CONN
32	0F5884	2	SCREW PHTT M3.5-0.6 X 10
33	0F5896	2	SCREW PHTT M3.5-0.6 X 16
34	0C2265	4	SCREW PHTT M4-0.7 X 12 ZYC
35	0C3990	2	SCREW PHTT M4-0.7 X 10 ZYC
36	091526	4	SCREW PPHM M5-0.8 X 12 ZNC
37	051716	9	NUT HEX M5-0.8 G8 CLEAR ZINC
38	079224	2	SCREW PPHM M5-0.8 X 30 SS
43	043182	7	WASHER LOCK M3
44	051714	7	NUT HEX M3-0.5 G8 YEL CHR
45	0F3192	1	SUPPORT ANGLE PCB
46	0E7403C	1	FUSE ATO TYPE 15 AMP (BLUE)
47	0G2281	1	HARN R-200 CTRL PNL 1800 RPM (NOT SHOWN)
<u>COMPONENTS INSTALLED PER THIS DRAWING</u>			
A	056739	1	RELAY SOLENOID 12VDC PNL MNT
B	022287	2	SCREW HHC 1/4-20 X 3/4 G5
C	022473	4	WASHER FLAT 1/4-M6 ZINC
D	022097	2	WASHER LOCK M6-1/4
E	022127	2	NUT HEX 1/4-20 STEEL
F	0F6145	A/R	SEAL WEATHER .45"DIA
G	0F2627A	1	COVER CONTROL PANEL SIDE
H	091526	4	SCREW PPHM M5-0.8 X 12 ZNC
J	049226	4	WASHER LOCK M5
K	051713	4	WASHER FLAT M5

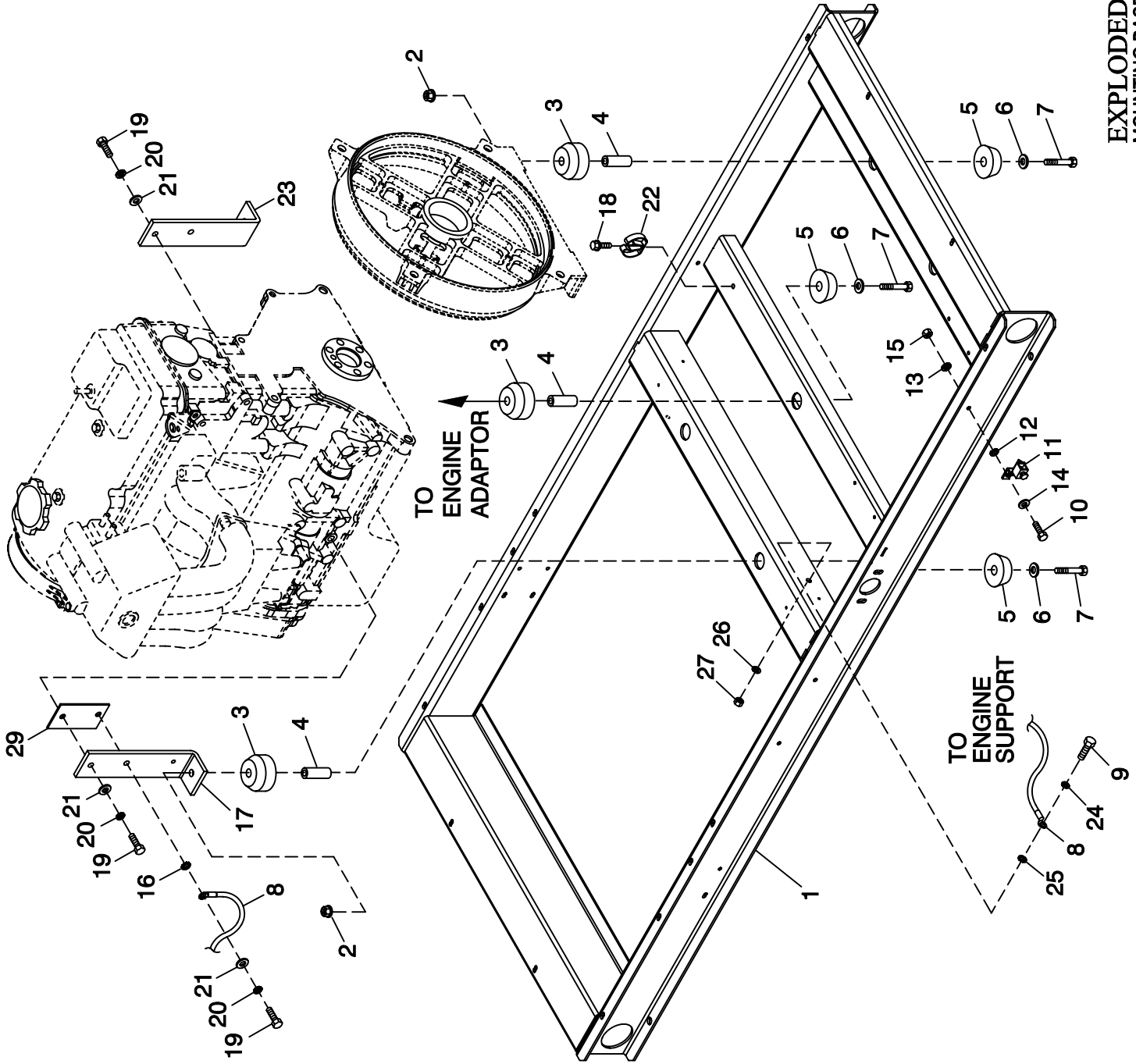

EXPLODED VIEW:
MOUNTING BASE 2.4L C2
DRAWING #: 0F9807

EXPLODED VIEW: MOUNTING BASE 2.4L C2**DRAWING #: 0F9807****GROUP C****APPLICABLE TO:**

ITEM	PART #	QTY.	DESCRIPTION
1	0F9517	1	WELDMENT FRAME 2.4L C2
2	052860	4	NUT FLANGED HEX M12-1.75
3	052251	5	DAMPENER VIBRATION 40 BLUE
4	052257	5	SPACER .49 X .62 X 1.87 PWDR/ZNC
5	052252	5	DAMPENER VIBRATION
6	052259	5	WASHER FLAT M12
7	052891	5	SCREW HHC M12-1.75 X 80 G8.8
8	0536210410	1	ASSY WIRE 14.00"
9	042909	1	SCREW HHC M8-1.25 X 30 G8.8
10	047411	1	SCREW HHC M6-1.0 X 16 G8.8
11	055414	1	LUG SLDLSS #2-#8 X 17/64 CU
12	022447	1	WASHER SHAKEPROOF INT 1/4
13	022097	1	WASHER LOCK M6-1/4
14	022473	2	WASHER FLAT M6-1/4 ZINC
15	049813	1	NUT HEX M6 -1.0 G8 YEL CHR
16	022261	1	WASHER SHAKEPROOF INT 3/8
17	0F9597A	1	SUPPORT LH ENGINE 2.4L
18	045764	1	SCREW HHTT M4-0.7 X 8 BP
19	062963	4	SCREW HHC M10-1.25 X 30 G8.8
20	022302	4	WASHER LOCK 7/16
21	022131	4	WASHER FLAT 3/8-M10 ZINC
22	065852	1	SPRING CLIP HOLDER .37-.62
23	0F9597	1	SUPPORT RH ENGINE 2.4L
24	022129	1	WASHER LOCK M8-5/16
25	026204	1	WASHER SHAKEPROOF INT 5/16
26	022145	1	WASHER FLAT 5/16-M8 ZINC
27	045771	1	NUT HEX M8-1.25 G8 CLEAR ZINC
29	0F9596	1	SPACER ENGINE MOUNT (2.4L G1)
	0F9596A	1	SPACER LH ENGINE MOUNT (2.4L G2)

GROUP C

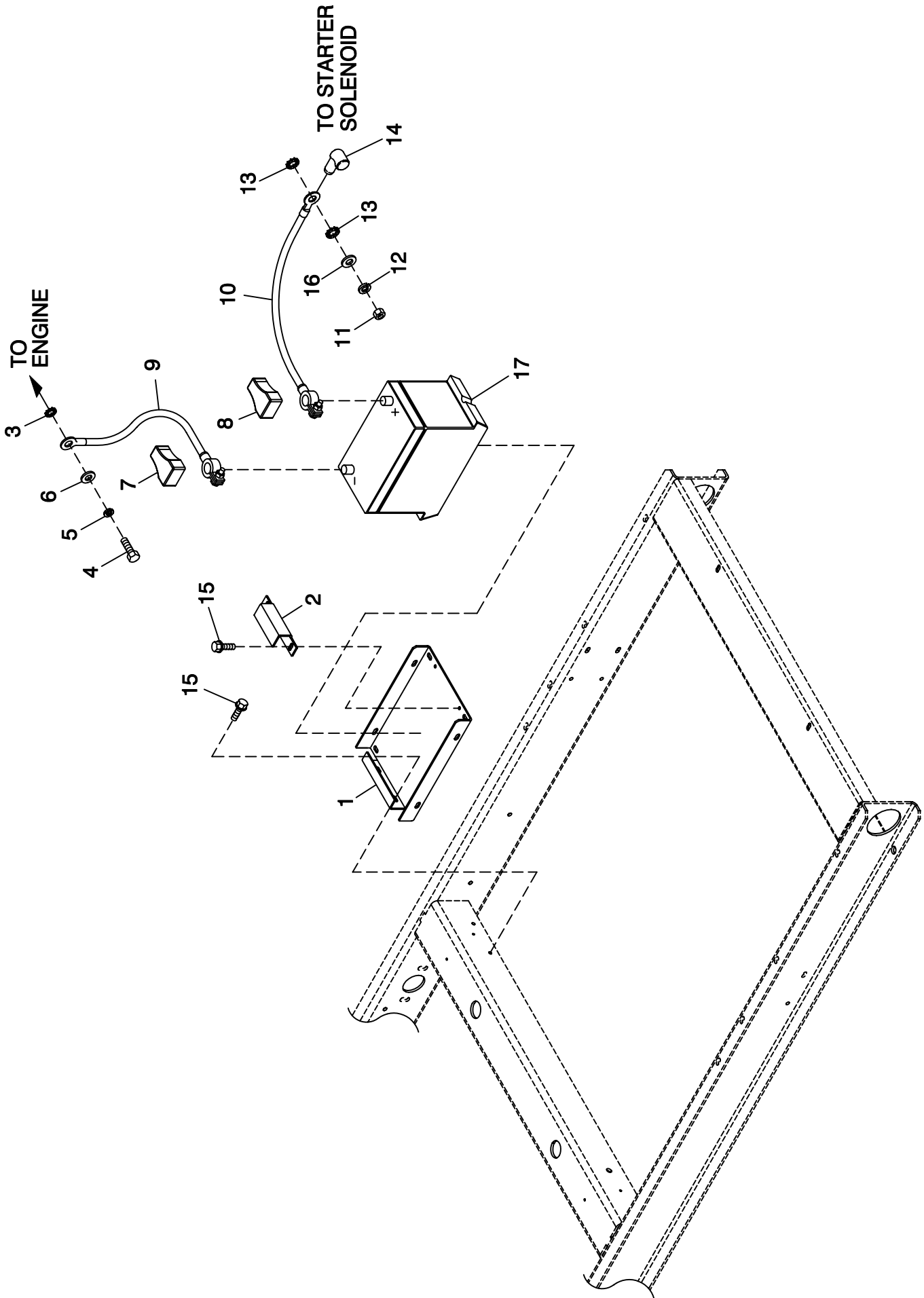

EXPLODED VIEW:
BATTERY 2.4L CPL
DRAWING #: 0F9813

EXPLODED VIEW: BATTERY 2.4L CPL**DRAWING #: 0F9813****GROUP C****APPLICABLE TO:**

ITEM	PART #	QTY.	DESCRIPTION
1	0F3408B	1	BATTERY TRAY C1 CPL
2	0F3411	1	STRAP BATTERY RETAINMENT
3	025507	REF	WASHER SHAKEPROOF EXT 7/16 STL
4	052212	REF	SCREW HHC M10-1.25 X 25 G8.8
5	046526	REF	WASHER LOCK M10
6	022131	REF	WASHER FLAT 3/8-M10 ZINC
7	050331A	REF	BATTERY POST COVER RED +
8	050331	REF	BATTERY POST COVER BLACK -
9	038805Y	1	CABLE BATTERY BLACK #1 X 18.00
10	03880400AE	1	CABLE BATT RED #1 X 18.00
11	045771	REF	NUT HEX M8-1.25 G8 YEL CHR
12	022129	REF	WASHER LOCK M8-5/16
14	0F3976	1	BOOT CONTACTOR CABLES
15	0C2454	4	SCREW THF M6-1 X 16 N WA Z/JS
16	022145	REF	WASHER FLAT 5/16-M8 ZINC
17	077483	REF	BATTERY 12VDC 75-AH 26

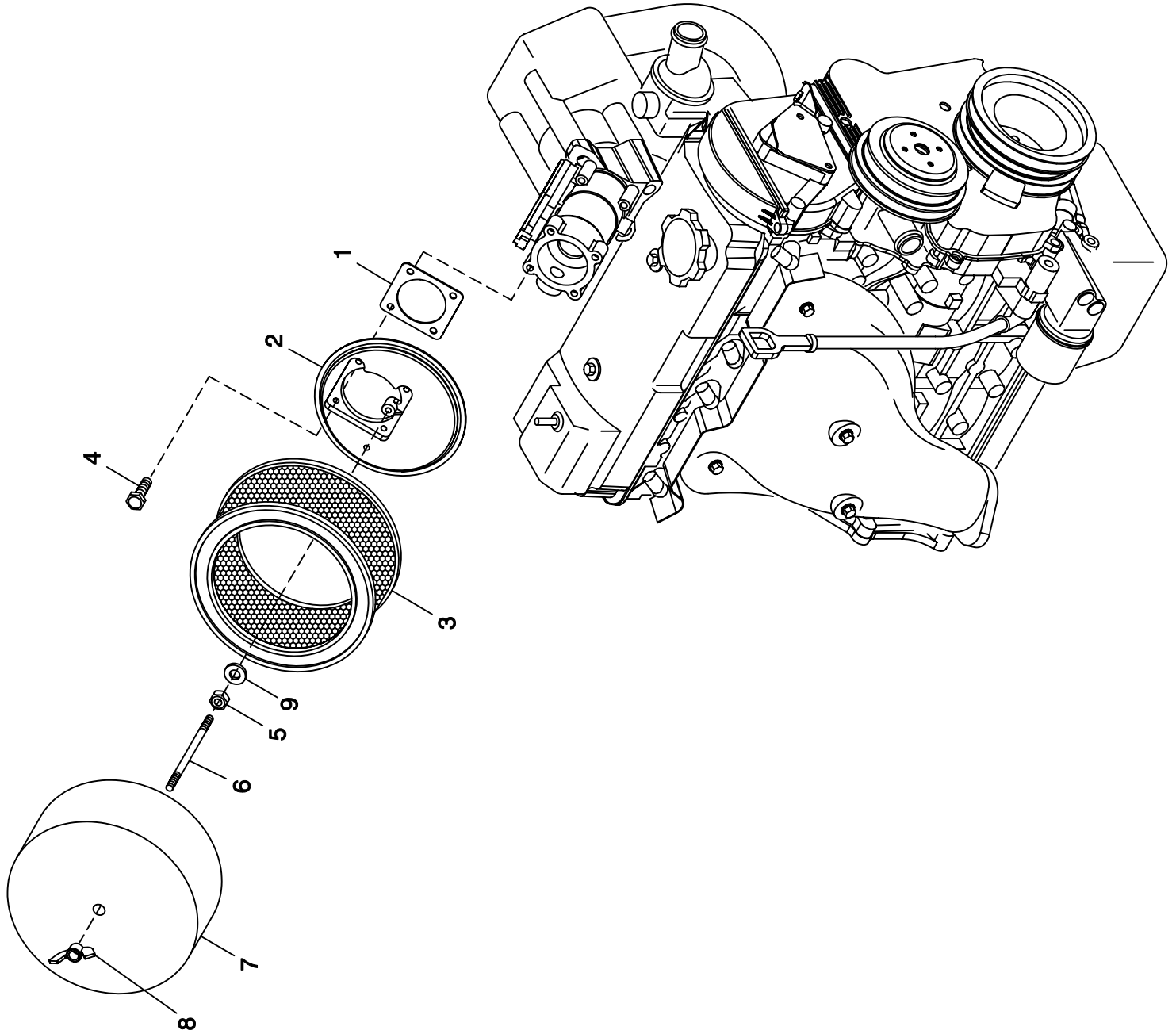

EXPLODED VIEW:
AIR CLEANER C2
DRAWING #: 0F9809

EXPLODED VIEW: AIR CLEANER C2

DRAWING #: 0F9809

GROUP D

APPLICABLE TO:

ITEM	PART #	QTY.	DESCRIPTION
1	0E6586	1	GASKET BOSCH 32 & 40
2	0E0519A	1	ADAPTER CARBURETOR W/PVC CONN
3	0C8127	1	ELEMENT AIR CLEANER
4	052619	4	SCREW HHC M5-0.8 X 20 G8.8
5	022127	1	NUT HEX 1/4-20 STEEL
6	062974	1	STUD TH 1/4-20 X 4-1/2 G2 ZNC
7	0G0190	1	PLATE, AIR CLEANER TOP 2.4L
8	037561	1	NUT WING 1/4-20 NYLK
9	022097	1	WASHER LOCK M6-1/4

GROUP D

INDICATION
MARK

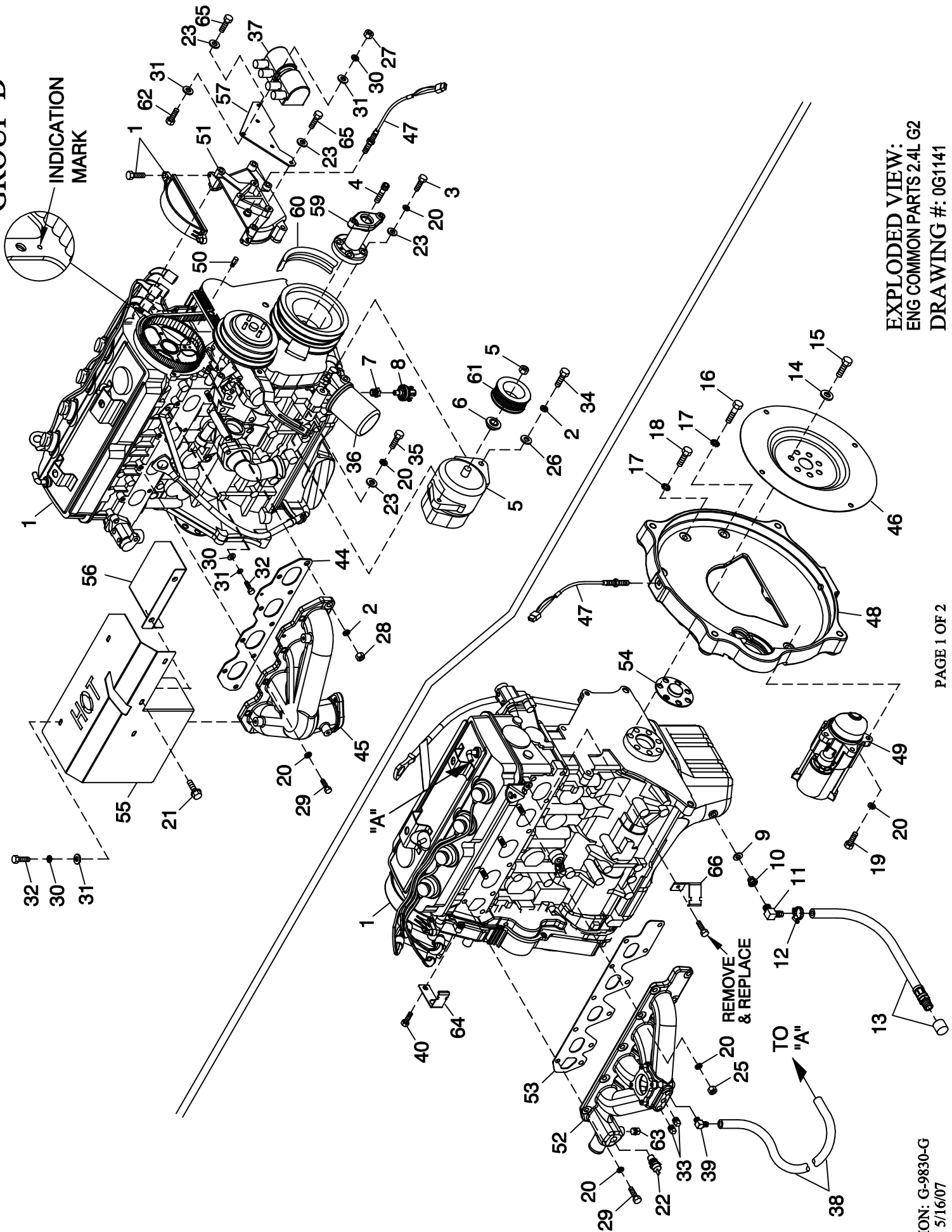

EXPLODED VIEW:
ENG COMMON PARTS 2.4L G2
DRAWING #: 0G1141

APPLICABLE TO:

ITEM	PART #	QTY.	DESCRIPTION
1	0G0408	1	ENGINE 2.4L MITSUBISHI 4G64
2	046526	3	WASHER LOCK M10
3	039414	4	SCREW HHC M8-1.25 X 35 G8.8
4	0G0149	1	SCREW SHC M14-1.5 X 35 G10.9
5	0E9868A	1	ALTERNATOR DC W/OUT PULLEY
(2) 6	0F3217	1	SPACER DC ALTERNATOR PULLEY
7	042574	1	ADAPTOR 1/8 NPTF TO 1/8 BSPT
8	0A8584	1	SWITCH OIL PRESSURE 10 PSI 2 POL (R-PANEL)
	0F4612	1	SENDER OIL PRESSURE 1/8" NPT (H-PANEL)
9	057772	1	WASHER NYLON .565
10	057765	1	ADAPTER M14-1.50 X 3/8 NPT
11	043790	1	BARBED EL 90 3/8 NPT X 3/8
12	0C7649	1	CLAMP HOSE .38-.87
13	069860E	1	HOSE DRAIN ASSY 28"
14	063076	7	WASHER FLAT .531 ID X 1.062 OD
15	0G1394	7	SCREW HHC M12-1.25 X 20 G10.9
16	052830	2	SCREW HHC M10-1.25 X 45 G8.8
17	025507	5	WASHER SHAKEPROOF EXT 7/16 STL
18	062963	3	SCREW HHC M10-1.25 X 30 G8.8
19	049821	3	SCREW SHC M8-1.25 X 30 G12.9
20	022129	26	WASHER LOCK M8-5/16
21	0D6029	3	SCREW THF M6-1 X 16 N WA Z/JJS
22	0A6751	1	SWITCH HI-TEMP 245D X 3/8 NPT (R-PANEL)
	0E0502	1	TEMPERATURE SENDER DELPHI (H-PANEL)
23	022145	7	WASHER FLAT 5/16-M8 ZINC
25	045771	3	NUT HEX M8-1.25 G8 CLEAR ZINC
26	022131	1	WASHER FLAT 3/8-M10 ZINC
27	049813	3	NUT HEX M6 X 1.0 G8 YEL CHR
28	046525	2	NUT HEX M10-1.25 G8 YEL CHR
29	058306	15	SCREW SHC M8-1.25 X 25 G12.9
30	022097	7	WASHER LOCK M6-1/4
31	022473	10	WASHER FLAT 1/4-M6 ZINC
32	043116	4	SCREW HHC M6-1.0 X 12 G8.8
33	026073A	2	PLUG STD PIPE 1/4 STEEL SQ HD
34	052243	1	SCREW HHC M10-1.5 X 60 G8.8
35	0A8258	1	SCREW HHC M8-1.25 X 25 G10.9
(1) 36	0G0664	1(REF)	OIL FILTER G2 ENGINE
37	0G1502	1	COIL PACK
38	047290	1	HOSE 3/8 ID SINGLE BRAID (15" LG)
39	049340	1	BARBED EL 90 1/4 NPT X 3/8
(3) 40	045757	1	SCREW HHC M6-1.0 X 25 G8.8
(1) 44	0G0951	1(REF)	GASKET EXHAUST MANIFOLD
45	0G3910	1	EXHAUST MANIFOLD G2 (MACHINE) (35KW & 45KW)
	0G0608	1	MANIFOLD EXHAUST (MACHINED) (25KW ONLY)
46	0F9965E	1	FLEX PLATE 2 POLE 2.4L G2
47	0D2244M	2	ASSY MAGPICKUP(3/8-24 MALE)
48	0F9420	1	ADAPTER ENGINE 2.4L MACHINE
49	0E9747	1	STARTER, 12 VOLT
50	0G1472A	1	CAM SENSOR PIN ASSY
51	0G1476	1(REF)	COVER CAM GEAR G2 REWORKED
52	0G0707	1	MANIFOLD INTAKE
(1) 53	0G0950	1(REF)	GASKET INTAKE MANIFOLD
54	0F9583	1	SPACER 2.4L G2 FLEX PLATE
55	0G0792	1	SHIELD HEAT G2
56	0G0792A	1	SHIELD HEAT SML
57	0G1501	1	BRACKET COIL PACK
59	0F9501	1	ADAPTER 2.4L CRANKSHAFT MACH
(1) 60	0G0952	1(REF)	POLY V-BELT G2 (3600 RPM)
	0D3488S	1	BELT SERPENTINE 37.0" (1800 RPM)
61	0G0788	1	PULLEY DC ALTERNATOR (3600 RPM)
	0G2750	1	PULLEY 69 OD DC ALTERNATOR (1800 RPM)
62	049721	3	SCREW HHC M6-1.0 X 35 G8.8 BLK
63	026925	1	PLUG STD PIPE 3/8 STEEL SQ HD
(3) 64	0F2776	1	BRACKET, SIGNAL CONDITIONER
65	052203	2	SCREW HHC M8-1.25 X 70 G8.8
(3) 66	0F2776D	1	BRACKET SIGNAL CONDITIONER (1) SUPPLIED WITH ENGINE. (2) NOT USED ON 1800 RPM UNITS. (3) USED WITH H-PANEL ONLY

GROUP D

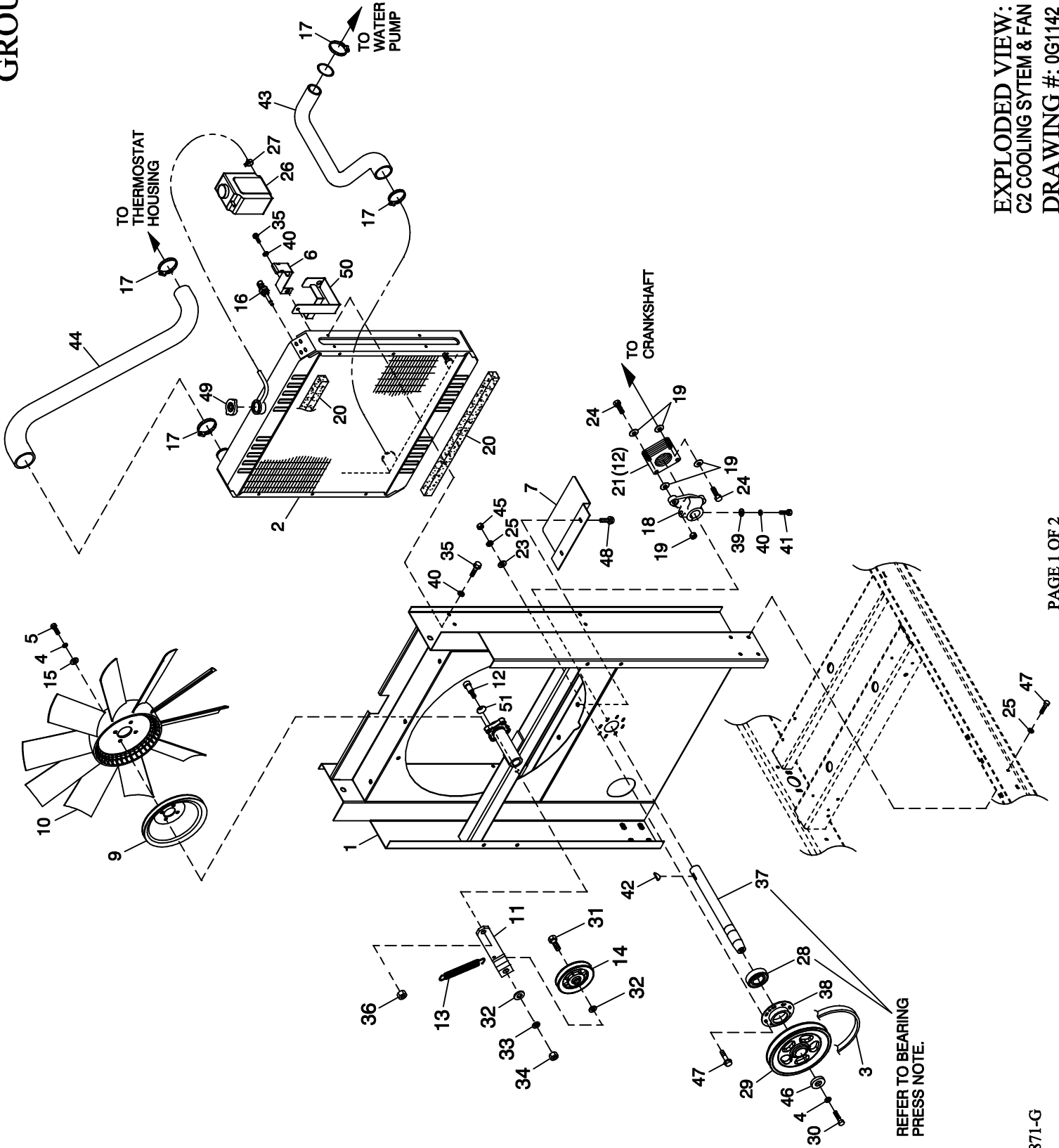

EXPLODED VIEW:
 C2 COOLING SYTEM & FAN DRIVE
 DRAWING #: 0G1142

EXPLODED VIEW: C2 COOLING SYTEM & FAN DRIVE
DRAWING #: 0G1142

GROUP D

APPLICABLE TO:

ITEM	PART #	QTY.	DESCRIPTION
1	0F9529	1	WELDMENT RADIATOR SUPPORT 2.4L
2	0F2608	1	RADIATOR 598 X 568 X 49 CPL RH
3	0F5263	1	V-BELT 31/64" X 57-3/8"
4	046526	5	WASHER LOCK M10
5	059981	4	SCREW HHC M10-1.5 X 30 G10.9
6	0F2776A	1	BRACKET, SIGNAL CONDITIONER (USED ONLY WITH QTA PRODUCT)
7	0F5050A	1	SHIELD RADIATOR C4
9	0F2573	1	PULLEY FAN V-GROOVE 9"
10	0F4011	1	FAN COOL 22" DIA 10 BLADE LH
11	0F2572	1	ARM TENSIONER
12	0G2990	1	SHOULDER BOLT 3/8 X 1/2"

ITEM	PART #	QTY.	DESCRIPTION
13	0F2862	1	SPRING TENSION CPL
14	0F2560	1	PULLEY V-BELT 4" FLANGED
15	022131	4	WASHER FLAT 3/8-M10 ZINC
16	0E2507	1	PROBE COOLANT LEVEL 3/8 NPTF
17	035685	4	CLAMP HOSE #28 1.32-2.25
18	0F2561	1	HUB FLEX PLATE
19	0C8145	8	WASHER FLEX (THIN)
20	052250	2	TAPE FOAM 1 X 1 (26.75" LG)
21	0C7043	12	DISK FLEX
23	022473	8	WASHER FLAT 1/4-M6 ZINC
24	0C8146	4	SCREW HHC 5/16-24 X 1.124
25	022097	16	WASHER LOCK M6-1/4
26	076749	1	TANK COOLANT RECOVERY
27	048031C	1	CLAMP HOSE BAND 1/4
28	031971	1	BEARING #6205 2NSE C3 E SRI2 S
29	0F4496	1	PULLEY 4.5" DIA MACHINED
30	042911	1	SCREW HHC M10-1.5 X 30 G8.8
31	0F2872	1	SCREW HHC 1/2-13 X 2" G8
32	022304	2	WASHER FLAT 1/2 ZINC
33	022195	1	WASHER LOCK 1/2
34	022196	1	NUT HEX 1/2-13 STEEL
35	0F8651	9	SCREW HHFC M8-1.25 X 20 W/M6
36	070015	1	NUT HEX LOCK 5/16-18 NY INS SS
37	0F9867	1	SHAFT FAN DRIVE
38	0F2461	1	RETAINER BEARING
39	022145	1	WASHER FLAT 5/16-M8 ZINC
40	022129	10	WASHER LOCK M8-5/16
41	039414	1	SCREW HHC M8-1.25 X 35 G8.8
42	082774	1	KEY WOODRUFF 4 X 19D
43	0G0795	1	HOSE LOWER RADIATOR G2
44	0G0816	1	HOSE UPPER RADIATOR G2
45	049813	8	NUT HEX M6 X 1.0 G8 YEL CHR
46	052644	1	SPACER .5 X 1.5 X .25 STL/ZINC
47	0C8566	16	SCREW HHFC M6-1.0 X 20 G8.8
48	0C2454	2	SCREW THF M6-1 X 16 N WA Z/JS
49	090283	1	CAP RADIATOR 13 PSI
50	080713	1	BRACKET COOLANT TANK
51	0G4376	1	WASHER BELLEVILLE .75X.38X.028

BEARING PRESS NOTE:

APPLY LOCTITE 620 BEARING RETAINMENT COMPOUND TO BEARING SURFACE ON ITEM 37 PRIOR TO PRESSING ITEM 28 ONTO ITEM 37. ALSO APPLY LOCTITE 620 BEARING RETAINMENT COMPOUND TO THE OUTSIDE OF 28 PRIOR TO INSTALLING ITEM 28 INTO ITEM 38.

APPLICABLE TO:

ITEM	PART #	QTY.	DESCRIPTION
1	026915	2	NIPPLE CLOSE 3/4 X 1.375
2	075580	1	FLANGE FUEL INLET
3	0F6390C	1	REGULATOR ASSY 2.4L (25KW)
	0F6390B	1	REGULATOR ASSY 2.4L (35KW & 45KW)
4	039253	2	SCREW HHC M8-1.25 X 20 G8.8
5	022145	2	WASHER FLAT 5/16-M8 ZINC
6	022129	2	WASHER LOCK M8-5/16
7	045771	2	NUT HEX M8-1.25 G8 CLEAR ZINC
9	0E8286	1	STREET EL 45D 1/2 NPT BRASS
10	026812	2	ELBOW 90D 3/4 NPT
11	0F8379	1	NIPPLE PIPE 3/4 NPT X 7
13	057823	2	CLAMP HOSE #10 .56 - 1.06
14	059057	1	HOSE 3/4 ID SAE-30R2 (18" LG)
15	047527	1	BARBED STR 1/2 NPT X 3/4
16	0D1509	1	DECAL INLET PRESSURE
17	050279	1	DECAL FUEL INLET NG (NATURAL GAS APPLICATION)
	050280	1	DECAL FUEL INLET LPG (LP VAPOR APPLICATION)
18	0F2119	1	O-RING 45.63 ID X 2.62 WIDTH
19	0E6586	1	GASKET BOSCH 32
20	0E4394	1	ACTUATOR BOSCH 40 GOVERNOR (45KW)
	0E4395	1	ACTUATOR BOSCH 32 GOVERNOR (25 & 35KW)
21	040105	1	HOSE COOL 2 IN ID 20R4 (45KW)
	057753B	1	HOSE 1.5 ID X 2 LG 20R4 (35KW)
22	0G4573C	1	MIXER ACTUATOR 32MM MACHINED (25KW)
	0G4573B	1	MIXER ACTUATOR 40MM MACHINED (35 & 45KW)
23	0F7790E	1	VENTURI THROTTLE 26MM (35 & 45KW)
	0F7790H	1	VENTURI THROTTLE 19MM (25KW)
24	0E7121	1	O-RING 47.625 ID X 2.38 WIDTH
26	022097	4	WASHER LOCK M6-1/4
27	046580	4	SCREW SHC M6-1.0 X 45 G12.9
28	035685	2	CLAMP HOSE #28 1.32-2.25
29	0F6155	1	HARNESS CPL FUEL JUMPER
30	047290	1	HOSE 3/8 ID SINGLE BRAID (18" LG)
32	057823	2	CLAMP HOSE #10 .56-1.06

RECONFIGURING THE FUEL SYSTEM

Note: All models are configured to run on natural gas from the factory.

To reconfigure the fuel system from NG to LP, follow these steps:

1. Turn the main gas supply off.
2. Remove the carburetor fuel hose from the outlet port of the demand regulator (See Detail "A").
3. Disconnect the power wires from the fuel solenoid located on top of the regulator assembly.
4. Loosen the spring clamp on the small fuel enrichment line and remove the hose from the hose barb.
5. Remove the black pipe assembly from the outlet port of the demand regulator.
6. Remove the NG fuel jet (loosen counter clockwise) from the outlet port.
7. Remove the LP fuel jet (loosen counter clockwise) from the jet keeper port on the side of the regulator housing. Install this jet into the outlet port in the regulator casting.

Note: The jet sizes are stamped on the individual jets. The larger jet size is used for running on NG.

8. Install the previously removed NG jet into the jet keeper port on the side of the regulator housing.
9. Install the previously removed black iron pipe onto the outlet port of the demand regulator.
10. Reverse steps 1-4 in this procedure to reactivate the demand regulator.
11. For LP vapor application substitute LPG fuel inlet decal p/n 050280 for NG fuel inlet decal p/n 050279 (Item 17).
12. When switching fuel types, the proper dip switch settings must be made to the control panel. See owners manual, fuel section, for more details.

GROUP F

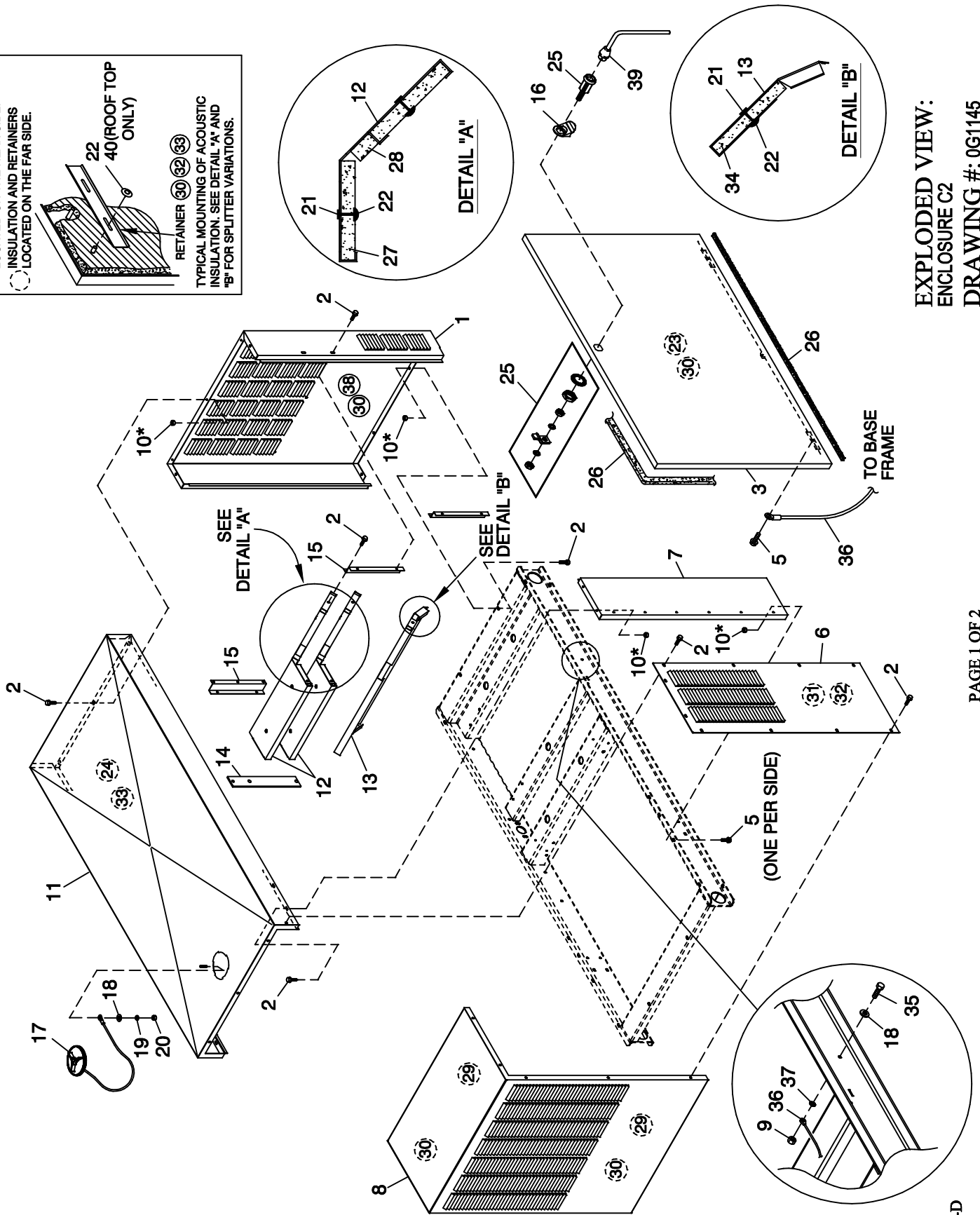
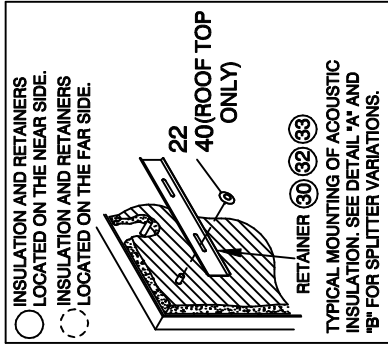

EXPLODED VIEW:
 ENCLOSURE C2
 DRAWING #: 0G1145

APPLICABLE TO:

ITEM	PART #	QTY.	DESCRIPTION
1	0G0045 (XX)	1	REAR WRAP C2 CPL
2	0C2454	54	SCREW THF M6-1 X 16 N WA Z/JS
3	0F5849 (XX)	2	DOOR C2
4	087233	2	RIVET POP .1875 X .450 SS
5	0E3257	4	SCREW TH-FRM M6 W/CAP SHKPRF W
6	0F5852 (XX)	2	DISCHARGE DUCT LH & RH SIDE C2
7	0F9833 (XX)	2	FRONT CORNERS C2
8	0F5851 (XX)	1	DISCHARGE CENTER DUCT C2
9	049813	2	NUT HEX M6 X 1.0 G8 YEL CHR
10 *	077992	21	NUT HEX LOCK M6-1.0 SS NY INS
11	0F9835 (XX)	1	ROOF C2
12	0F2786	2	SPLITTER C4
13	0F2785	1	SPLITTER LOWER C4
14	0F3364	1	SPLITTER STINGER C2
15	0F4880	2	SUPPORT SPLITTER LH C2
16	0F5049	2	TAB PULL
17	0C2634A	1	ASSEMBLY COVER ACCESS
18	022473	3	WASHER FLAT 1/4-M6 ZINC
19	022097	1	WASHER LOCK M6-1/4
20	022127	1	NUT HEX 1/4-20 STEEL
21	0F3072	10	INSULATION RETAINMENT HANGER
22	078115	38	WASHER SELF LOCKING DOME #4-40
23	0F4051	2	INSULATION DOOR C2
24	0F4051A	1	INSULATION ROOF TOP
25	0F5048D	2	WISE-ACTION LATCH SLOTTED CIR
26	0E5968	1	GASKET EXTRUDED TRIM (328" LG)
27	0F3760K	2	INSULATION SPLITTER
28	0F3760E	2	INSULATION SPLITTER
29	0F4051C	2	INSULATION DUCT
30	0F3890B	10	RETAINER INSULATION (820)
31	0F4051B	2	INSULATION DUCT SIDES
32	0F3890	4	RETAINER INSULATION (450)
33	0F3890A	3	RETAINER INSULATION (740)
34	0F3760L	1	INSULATION LOWER SPLITTER
35	042568	2	SCREW HHC M6-1.0 X 20 G8.8
36	0912970094	2	ASSY WIRE 14 AWG 34.8" GRN/YEL
37	022447	2	WASHER SHAKEPROOF INT 1/4
38	0F4051E	1	INSULATION REAR WRAP
39	0F8869D	1	KEY WISE-ACTION LATCH SLOT CIR
40	078115A	6	WASHER SELF LOCKING DOME #8-32

OPTIONAL COMPARTMENT MATERIALS:

ALL P/N'S WITH AN (XX) SUFFIX INDICATE A MULTIPLE MATERIAL AND COLOR OPTION.
USE THE FOLLOWING LEGEND TO IDENTIFY THE CORRECT PART NUMBER:

PART NO.	MATERIAL	COLOR
0XXXXXSN	STEEL	TAN
0XXXXXAN	ALUMINUM	TAN
0XXXXXSG	STEEL	GRAY
0XXXXXAG	ALUMINUM	GRAY

* ALUMINUM ENCLOSURE NOTE: ALL ENCLOSURE PANELS THAT FASTEN TO THE BASE FRAME MUST BE SECURED USING ITEM 2 & 5 THREAD FORMING FASTENER AND ITEM 39 LOCK NUT. LOCK NUT IS TO BE INSTALLED AFTER THREAD FORMING FASTENER HAS PENETRATED THROUGH EXTRUSIONS IN ENCLOSURE PANELS. ALL ROOF PANELS ARE TO BE SECURED IN THE SAME MANNER.

EXPLODED VIEW: MUFFLER EXHAUST**DRAWING #: 0G1146****GROUP F****APPLICABLE TO:**

ITEM	PART #	QTY.	DESCRIPTION
1	0F9794	2	MUFFLER 7" X 9" X 18-1/2" 2" IN/OUT
2	0G0113	1	EXHAUST ELBOW 2 1/4 OD 2 1/2OD
3	0G1007	1	BRACKET MUFFLER
4	0F2830	2	MUFFLER BRACKET STIFFENER
5	0F2962	2	MUFFLER STRAP
6	080762	5	BOLT U 3/8-16 X 2.62
7	0E0170A	1	EXHAUST BLANKET 988MM (C2)
8	0C2454	4	SCREW THF M6-1 X 16 N WA Z/JS
9	0G0776	1	PIPE EXHAUST G2
10	0G0007	1	DIFFUSER EXHAUST WELDMENT
11	044149	1	GASKET EXHAUST RING
12	085917	2	WASHER LOCK 3/8 SS
13	0D2611	2	SCREW HHC 3/8-16 X 1-3/4 SS
14	0E8816	1	EXHAUST FLANGE 2" PIPE
15	049721	4	SCREW HHC M6-1.0 X 35 G8.8 BLK
16	022097	4	WASHER LOCK M6-1/4
17	022473	4	WASHER FLAT 1/4-M6 ZINC
18	036797	1	BOLT U 5/16-18 X 2.25
19	022259	2	NUT HEX 5/16-18 STEEL
20	070006	2	WASHER LOCK M8 SS
21	088775	2	WASHER FLAT 3/8 SS
22	022241	10	NUT HEX 3/8-16 STEEL
23	085917	10	WASHER LOCK 3/8 SS
24	0F2809	1	PIPE EXHAUST CROSSOVER
25	0F2808B	1	PIPE EXHAUST MUFFLER OUT

* NOT USED ON OPEN SET.

GROUP G

OPTION 1 - SINGLE PHASE, H-100 CONTROL PANEL

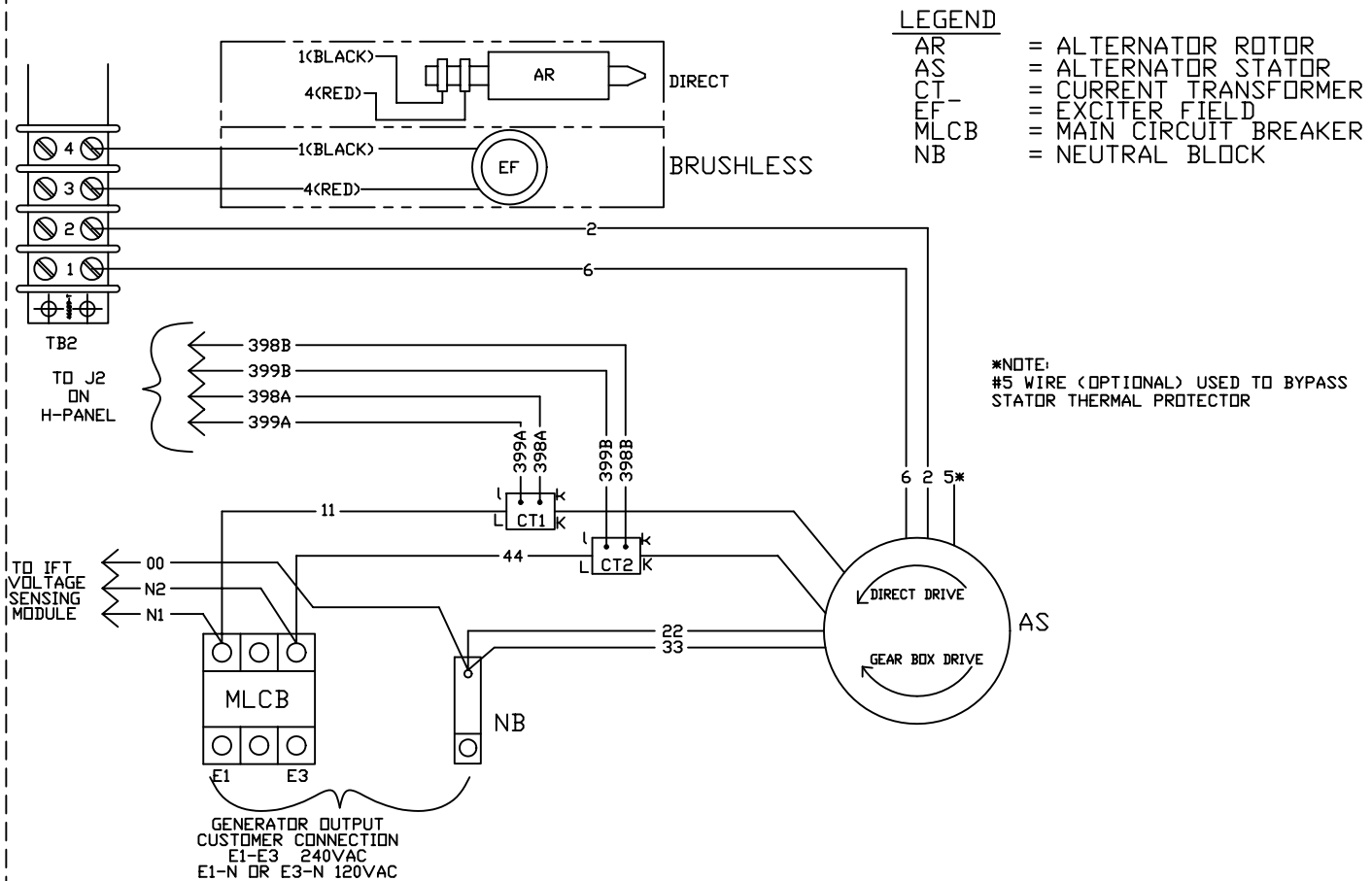

OPTION 2 - THREE PHASE, H-100 CONTROL PANEL DIRECT DRIVE, 6 LEAD

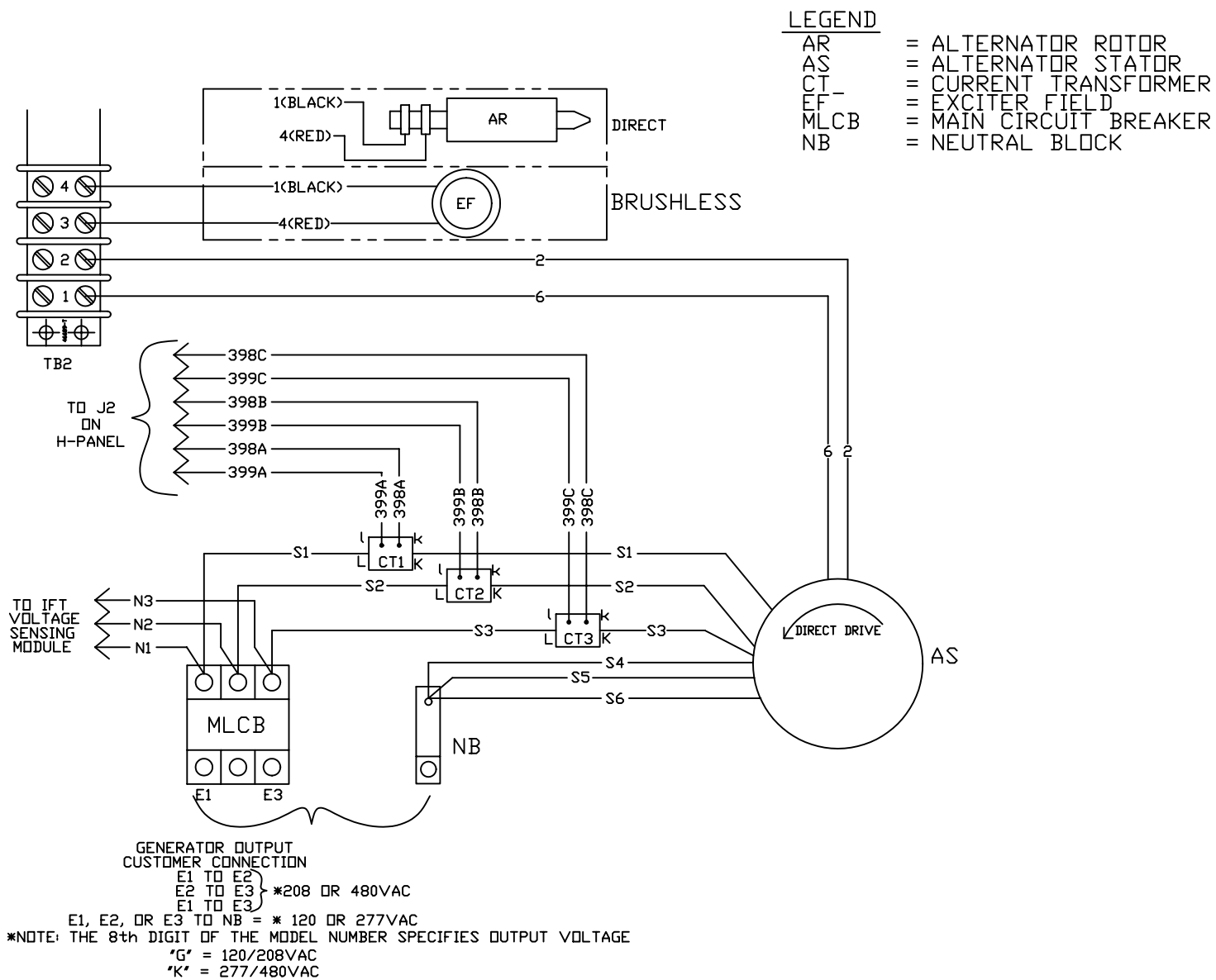

OPTION 3 - THREE PHASE, H-100 CONTROL PANEL GEAR BOX (REVERSE ROTATION)

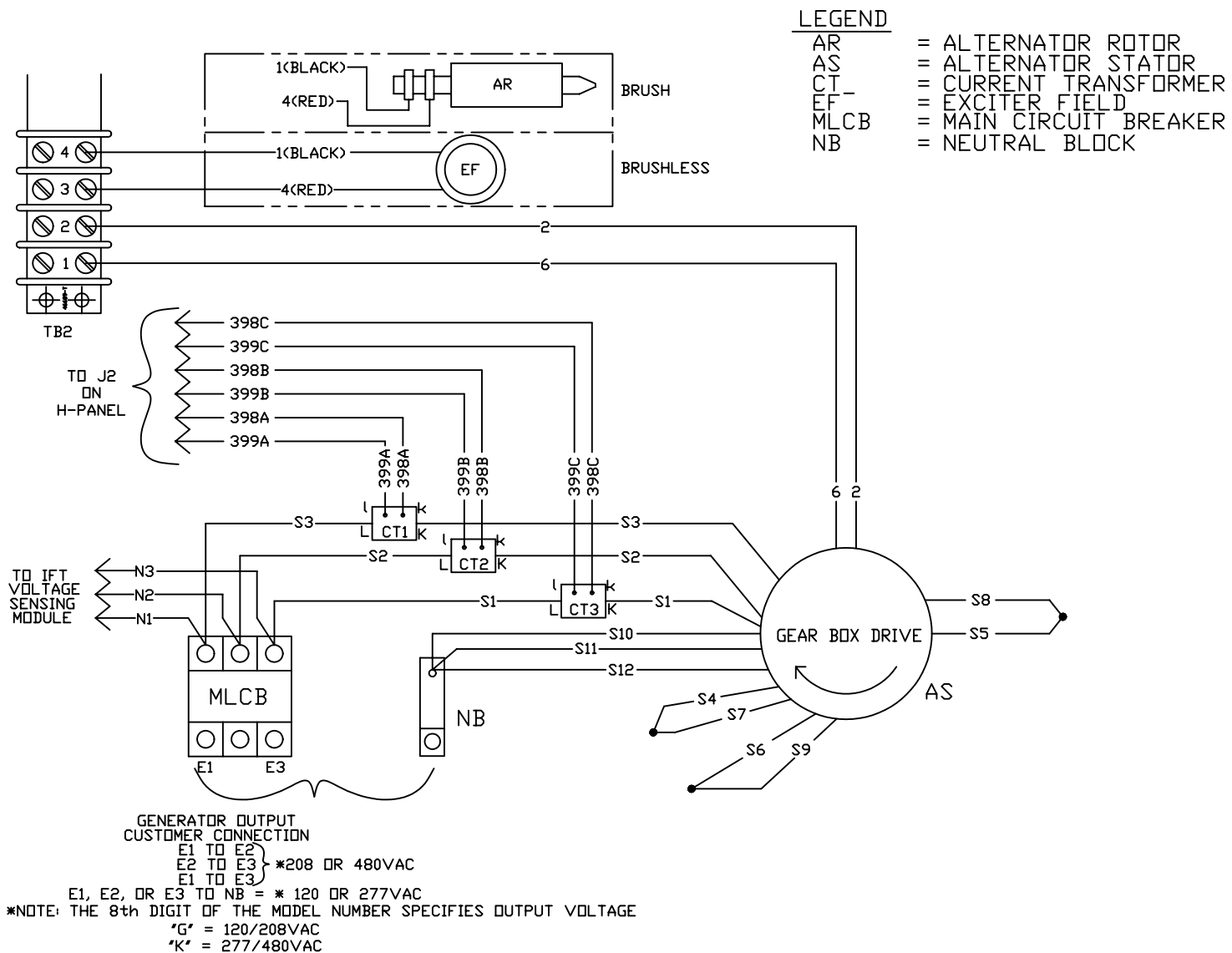

OPTION 4 - THREE PHASE DELTA, H-100 CONTROL PANEL DIRECT DRIVE, 7 LEAD

LEGEND

- AR = ALTERNATOR ROTOR
- AS = ALTERNATOR STATOR
- CT = CURRENT TRANSFORMER
- EF = EXCITER FIELD
- MLCB = MAIN CIRCUIT BREAKER
- NB = NEUTRAL BLOCK

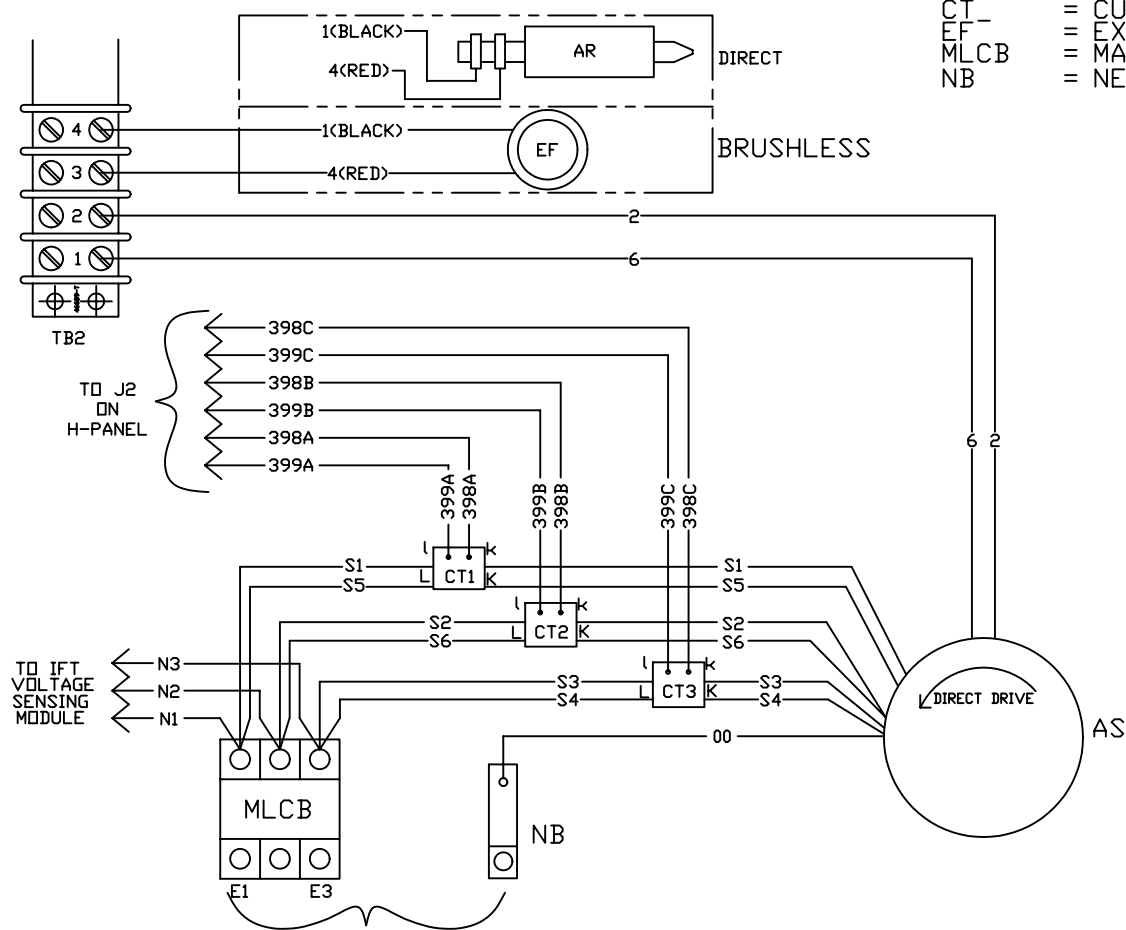

GENERATOR OUTPUT
CUSTOMER CONNECTION

E1 TO E2 } 240VAC
E2 TO E3 }
E1 TO E3 }

E1-N OR E3-N = 120VAC

*NOTE: THE 8th DIGIT OF THE MODEL NUMBER SPECIFIES OUTPUT VOLTAGE
J = 120/240VAC

OPTION 1 - SINGLE PHASE, R-SERIES CONTROL PANEL, 240V

LEGEND

- AR = ALTERNATOR ROTOR
- AS = ALTERNATOR STATOR
- MLCB = MAIN CIRCUIT BREAKER
- NB = NEUTRAL BLOCK

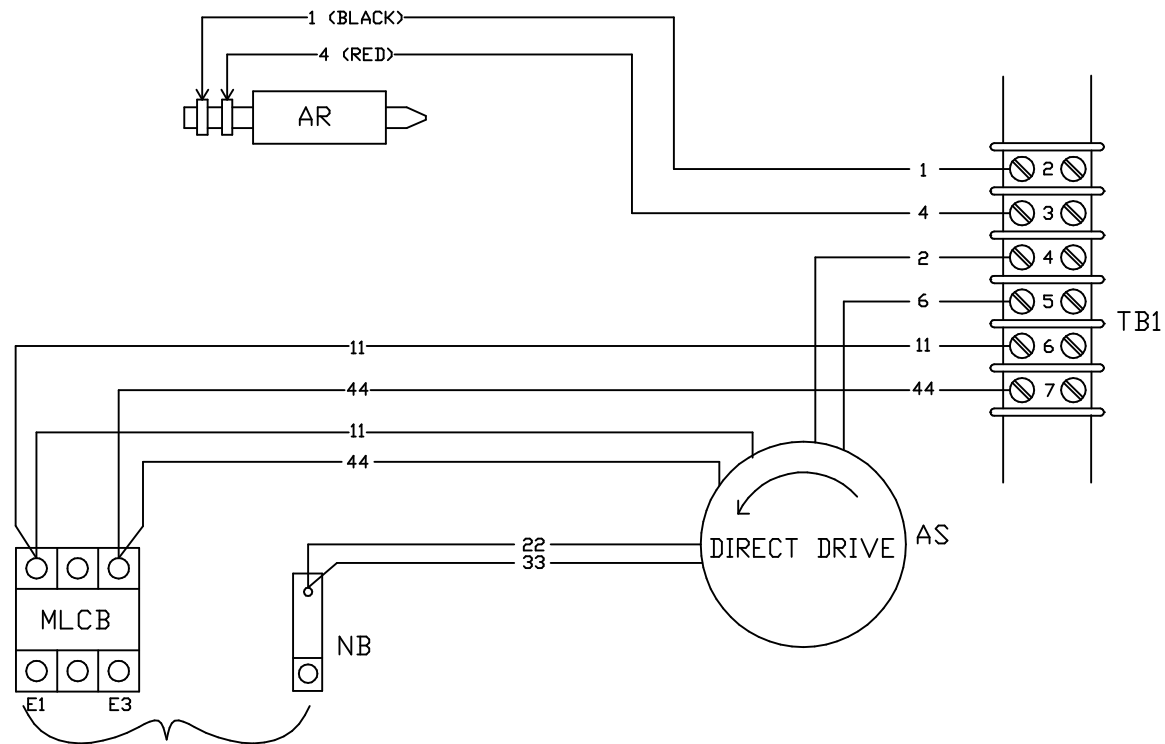

GENERATOR OUTPUT
CUSTOMER CONNECTION

- E1 - E3 = 240VAC
- E1 - NB = 120VAC
- E3 - NB = 120VAC

OPTION 2 - THREE PHASE, R-SERIES CONTROL PANEL, 6-WIRE 120/208V

LEGEND

- AR = ALTERNATOR ROTOR
- AS = ALTERNATOR STATOR
- MLCB = MAIN CIRCUIT BREAKER
- NB = NEUTRAL BLOCK

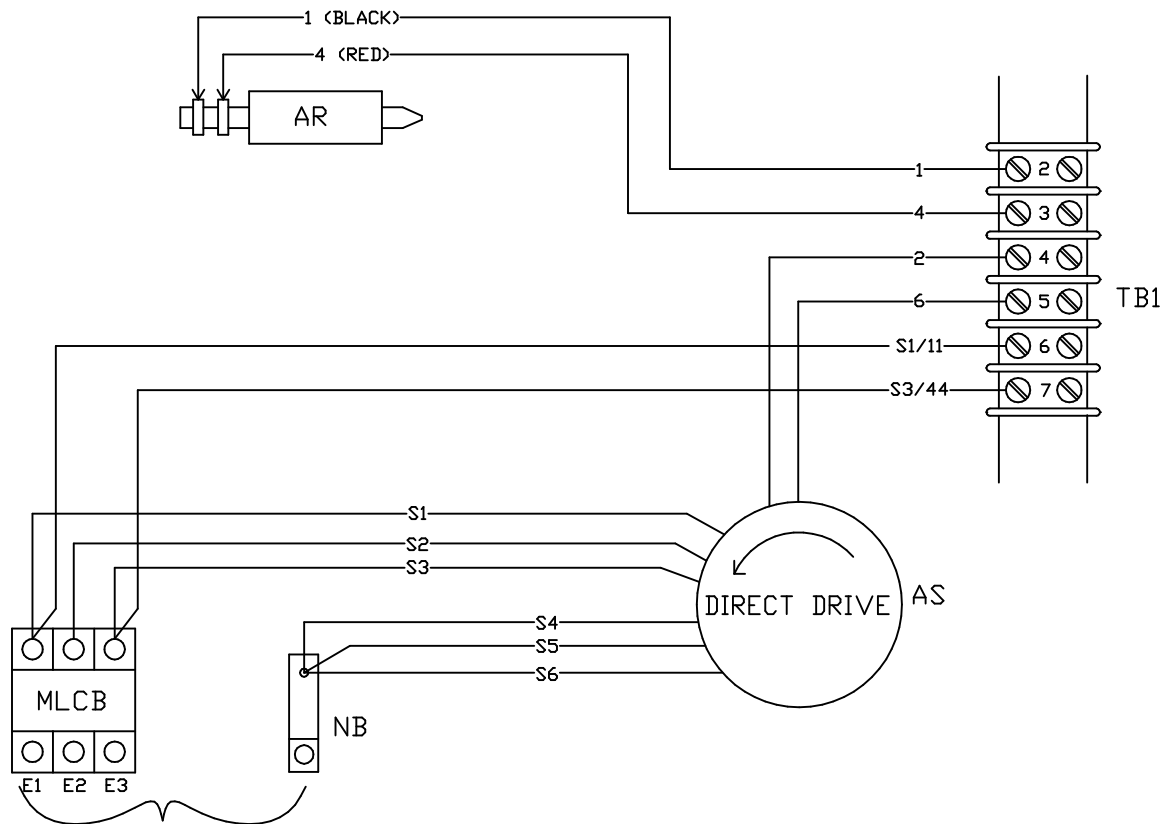

GENERATOR OUTPUT
CUSTOMER CONNECTION

E1 TO E2 }
E2 TO E3 } *208VAC
E1 TO E3 }

E1, E2, OR E3 TO NB = * 120VAC

*NOTE: THE 8th DIGIT OF THE MODEL NUMBER SPECIFIES OUTPUT VOLTAGE

"G" = 120/208VAC

OPTION 3 - THREE PHASE, R-SERIES CONTROL PANEL, 6-WIRE 277/480V

LEGEND

- AR = ALTERNATOR ROTOR
- AS = ALTERNATOR STATOR
- MLCB = MAIN CIRCUIT BREAKER
- NB = NEUTRAL BLOCK

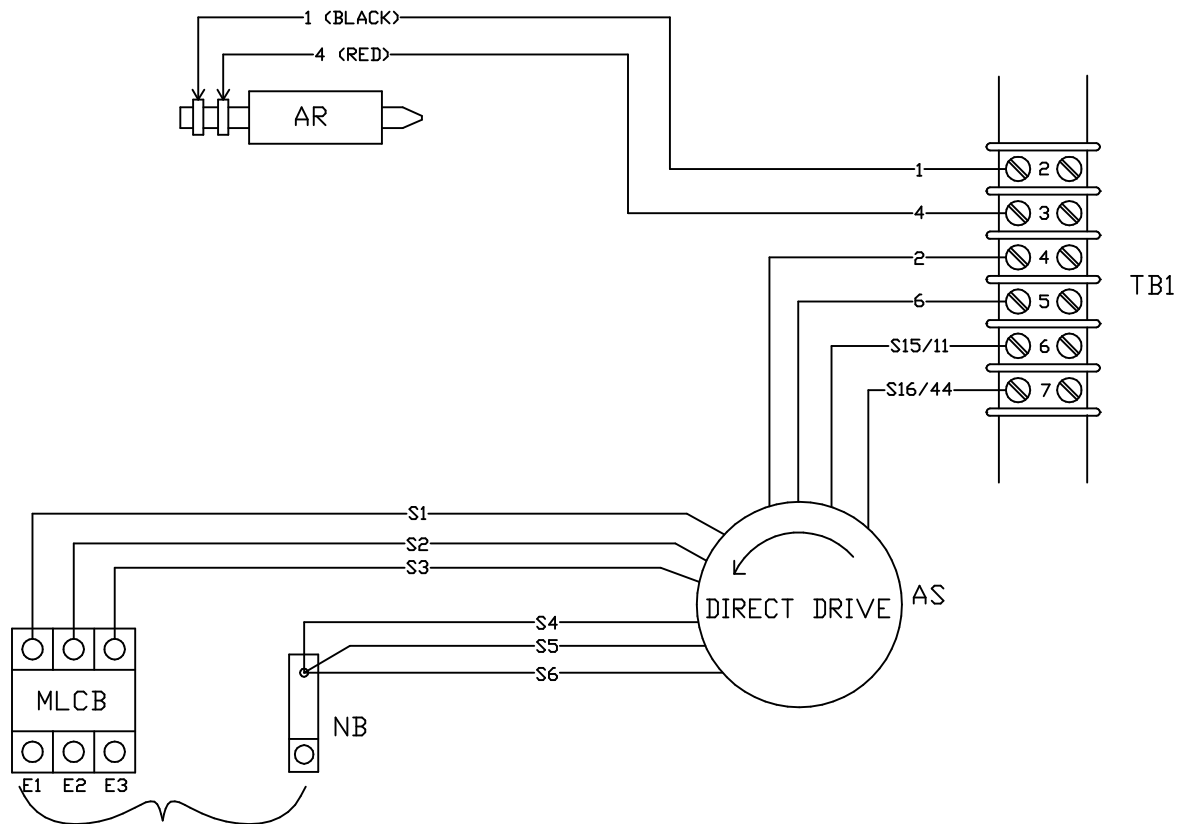

GENERATOR OUTPUT
CUSTOMER CONNECTION

E1 TO E2 }
E2 TO E3 } *480VAC
E1 TO E3 }

E1, E2, OR E3 TO NB = * 277VAC

*NOTE: THE 8th DIGIT OF THE MODEL NUMBER SPECIFIES OUTPUT VOLTAGE

"K" = 227/480VAC

OPTION 4 - THREE PHASE, R-SERIES CONTROL PANEL, 12-WIRE 120/208

LEGEND

- AR = ALTERNATOR ROTOR
- AS = ALTERNATOR STATOR
- MLCB = MAIN CIRCUIT BREAKER
- NB = NEUTRAL BLOCK

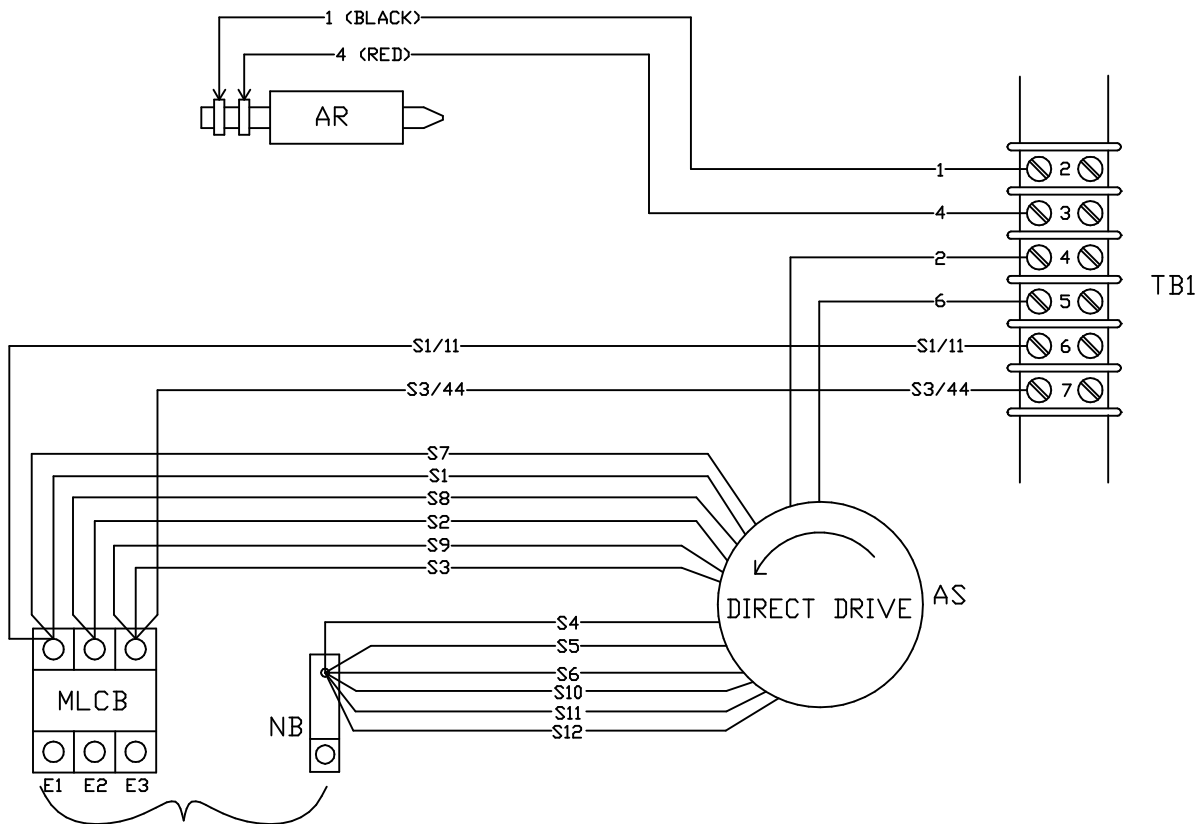

GENERATOR OUTPUT CUSTOMER CONNECTION

E1 TO E2 }
 E2 TO E3 } *208VAC
 E1 TO E3 }

E1, E2, OR E3 TO NB = * 120VAC

*NOTE: THE 8th DIGIT OF THE MODEL NUMBER SPECIFIES OUTPUT VOLTAGE

"G" = 120/208VAC

OPTION 5 - THREE PHASE DELTA, R-SERIES CONTROL PANEL, 7-WIRE 120/240V

LEGEND

- AR = ALTERNATOR ROTOR
- AS = ALTERNATOR STATOR
- MLCB = MAIN CIRCUIT BREAKER
- NB = NEUTRAL BLOCK

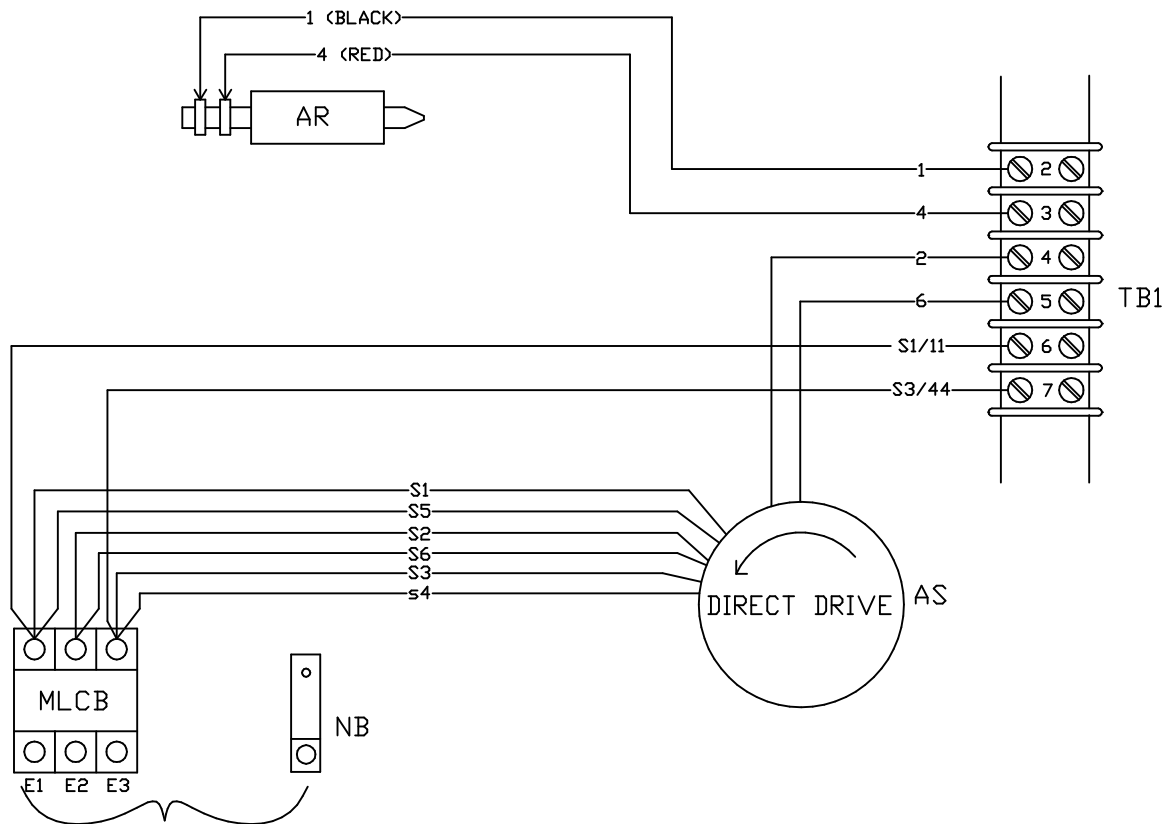

GENERATOR OUTPUT
CUSTOMER CONNECTION

E1 TO E2 }
E2 TO E3 } *240VAC
E1 TO E3 }

E1, OR E3 TO NB = * 120VAC

*NOTE: THE 8th DIGIT OF THE MODEL NUMBER SPECIFIES OUTPUT VOLTAGE
"j" = 120/240VAC

WEIGHT DATA
2.4L 25 KW, 35 & 45KW 642KG (1414 LB)
WOODEN SHIPPING SKIDS INCREASE OVERALL WEIGHT - 42KG (98 LB)

NOTES:

- 1) MINIMUM RECOMMENDED CONCRETE PAD SIZE: 1155 (45.5") WIDE X 2255 (88.8") LONG. REFERENCE INSTALLATION GUIDE SUPPLIED WITH UNIT FOR CONCRETE PAD GUIDELINES.
- 2) ALLOW SUFFICIENT ROOM ON ALL SIDES OF THE GENERATOR FOR MAINTENANCE AND SERVICING. THIS UNIT MUST BE INSTALLED IN ACCORDANCE WITH CURRENT APPLICABLE NFPA 37 AND NFPA 70 STANDARDS AS WELL AS ANY OTHER FEDERAL, STATE AND LOCAL CODES FOR MINIMUM DISTANCES FROM OTHER STRUCTURES.
- 3) CIRCUIT BREAKER INFORMATION:
SEE SPECIFICATION SHEET WITHIN OWNERS MANUAL
- 4) INSIDE STUB-UP AREA FOR AC LEAD LEAD CONDUIT CONNECTION, NEUTRAL CONNECTION, BATTERY CHARGER 120 VOLT AC (.5 AMP MAX.) CONNECTION, AND ACCESS TO TRANSFER SWITCH CONTROL WIRES. REMOVE FRONT COVER FOR ACCESS.
- 4A) FIELD CUT HOLE IS ONLY REQUIRED FOR MOUNTING OF GENERATOR ON AN EXISTING PAD.
- 5) REFERENCE OWNERS MANUAL FOR LIFTING WARNINGS.
- 6) REMOVE EITHER LEFT OR RIGHT HAND SIDE PANEL TO ACCESS EXHAUST MUFFLER AND FAN BELT.

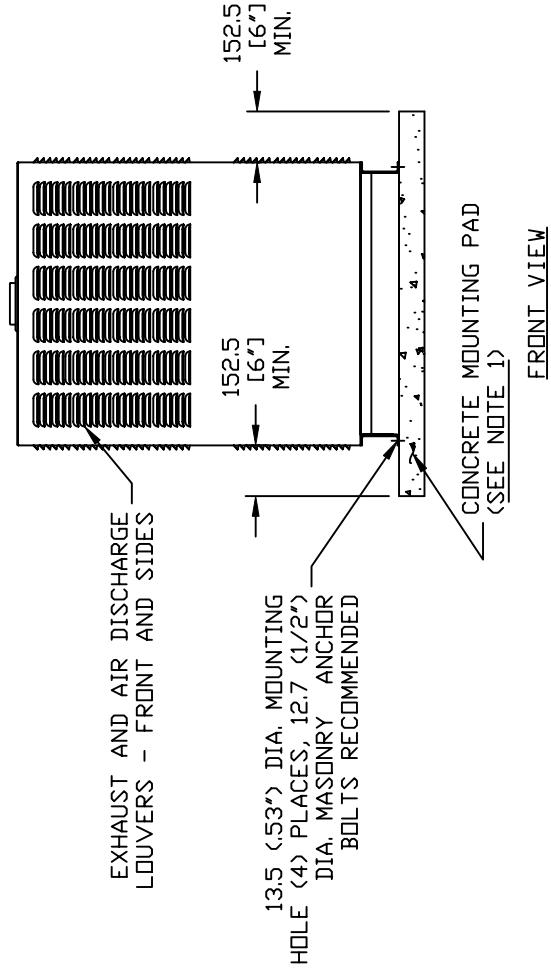

GROUP G

SERVICE ITEM ACCESSIBILITY CHART

SERVICE ITEM	2. 4L
OIL FILL CAP	EITHER DOOR
OIL DIP STICK	THRU RIGHT DOOR
OIL FILTER	THRU RIGHT DOOR
OIL DRAIN HOSE	THRU RIGHT DOOR
RADIATOR DRAIN HOSE	THRU LEFT DOOR
AIR CLEANER ELEMENT	EITHER DOOR
SPARK PLUGS	THRU RIGHT DOOR
MUFFLER	SEE NOTE 6
FAN BELT	SEE NOTE 6
BATTERY	THRU LEFT DOOR

REFERENCE OWNERS MANUAL FOR PERIODIC REPLACEMENT PART LISTINGS

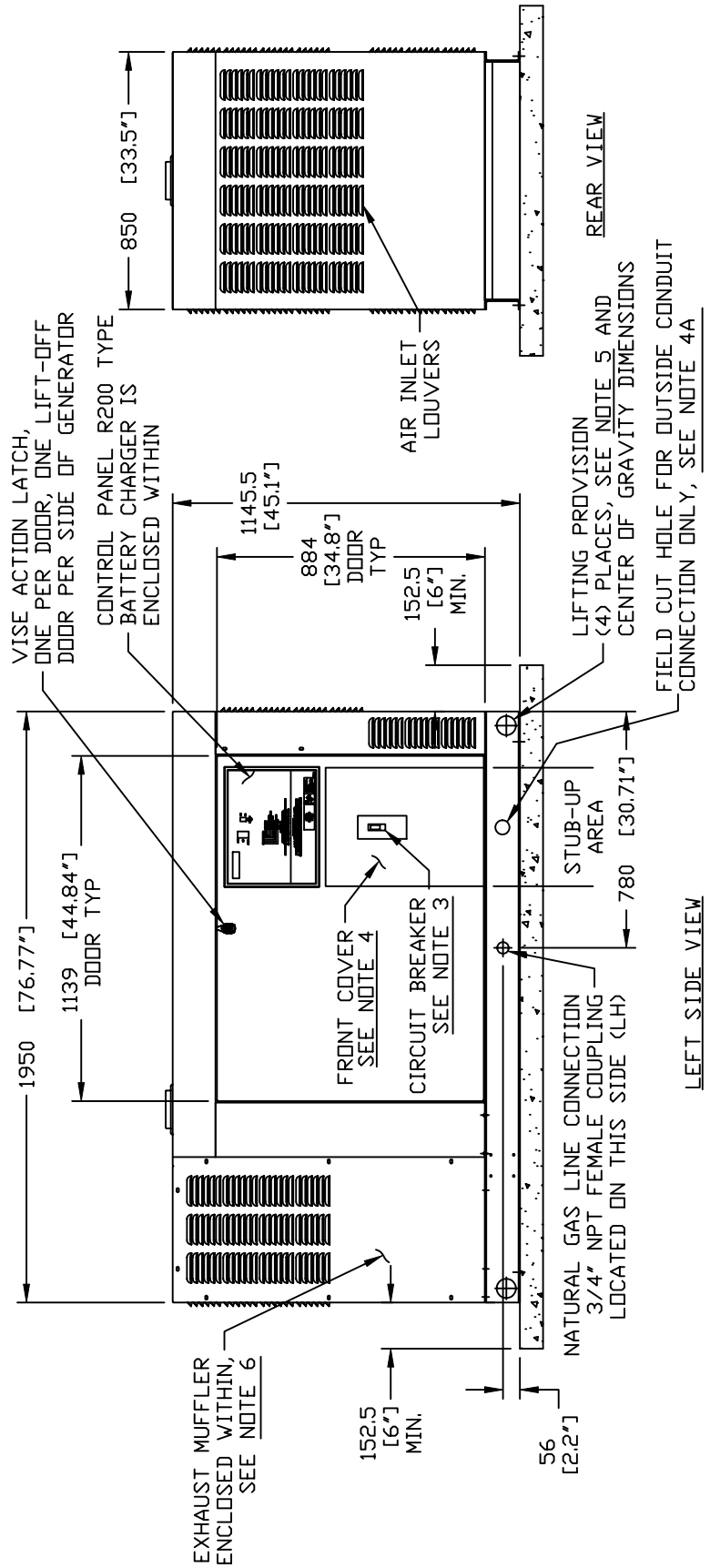
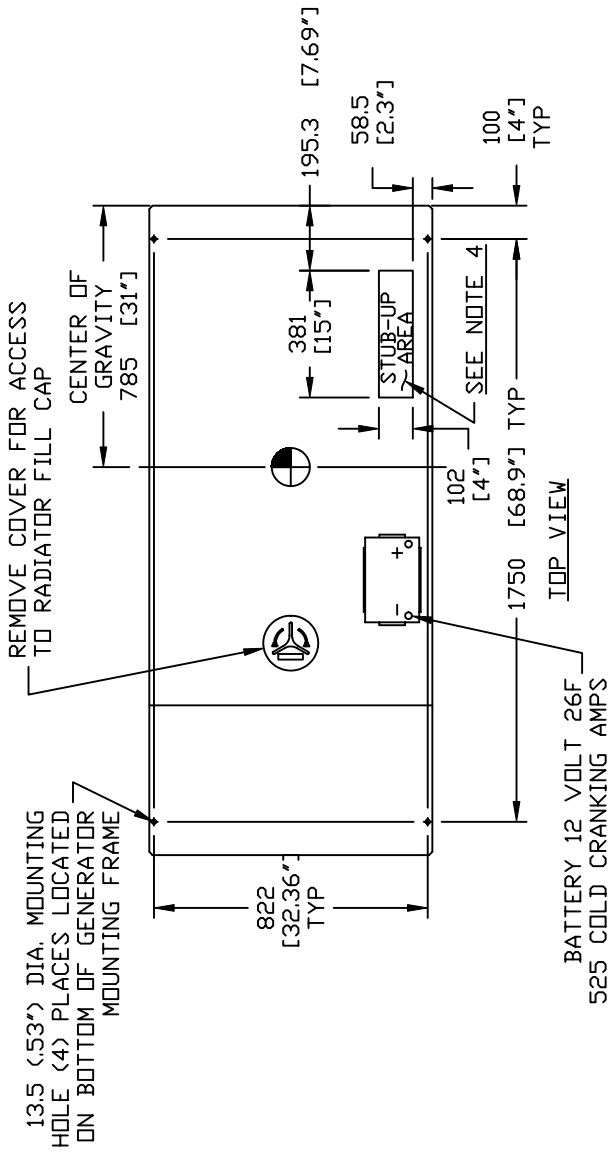

EXPLODED VIEW:
INSTL TN DRAWING 2.4L 25 KW, 35KW & 45KW
DRAWING #: 0G0325

GROUP G

CUSTOMER CONNECTION

& ALTERNATOR LEGEND:

- BA - BRUSH ASSEMBLY (GENERATOR)
- ICT - INTERCONNECT TERMINAL BLOCK
- MCB - MAINLINE CIRCUIT BREAKER
- NB - NEUTRAL BLOCK
- UCT - UTILITY CONNECT TERMINAL BLOCK

ENGINE WIRING LEGEND

- AFS - AIR/FUEL SOLENOID
- ALT - D.C. CHARGE ALTERNATOR
- BAT - 12VDC BATTERY
- CC - STARTER CONTACTOR
- CP - COIL PACK
- DEG - DRIVER ELEC. GOVERNOR
- FS - FUEL SOLENOID
- FS2 - AUX. FUEL SOLENOID
- GND - GROUND
- GOV - ELEC. GOVERNOR ACTUATOR
- HCT - HIGH COOLANT TEMP SWITCH
- J1 - CONNECTOR 1 (ON PCB)
- LFP - LOW FUEL PRESSURE SWITCH
- LOS - LOW OIL PRESSURE SWITCH
- MP1,2 - MAGNETIC PICKUP
- O2 - OXYGEN SENSOR
- SM - STARTER MOTOR
- WLS - COOLANT LEVEL SWITCH

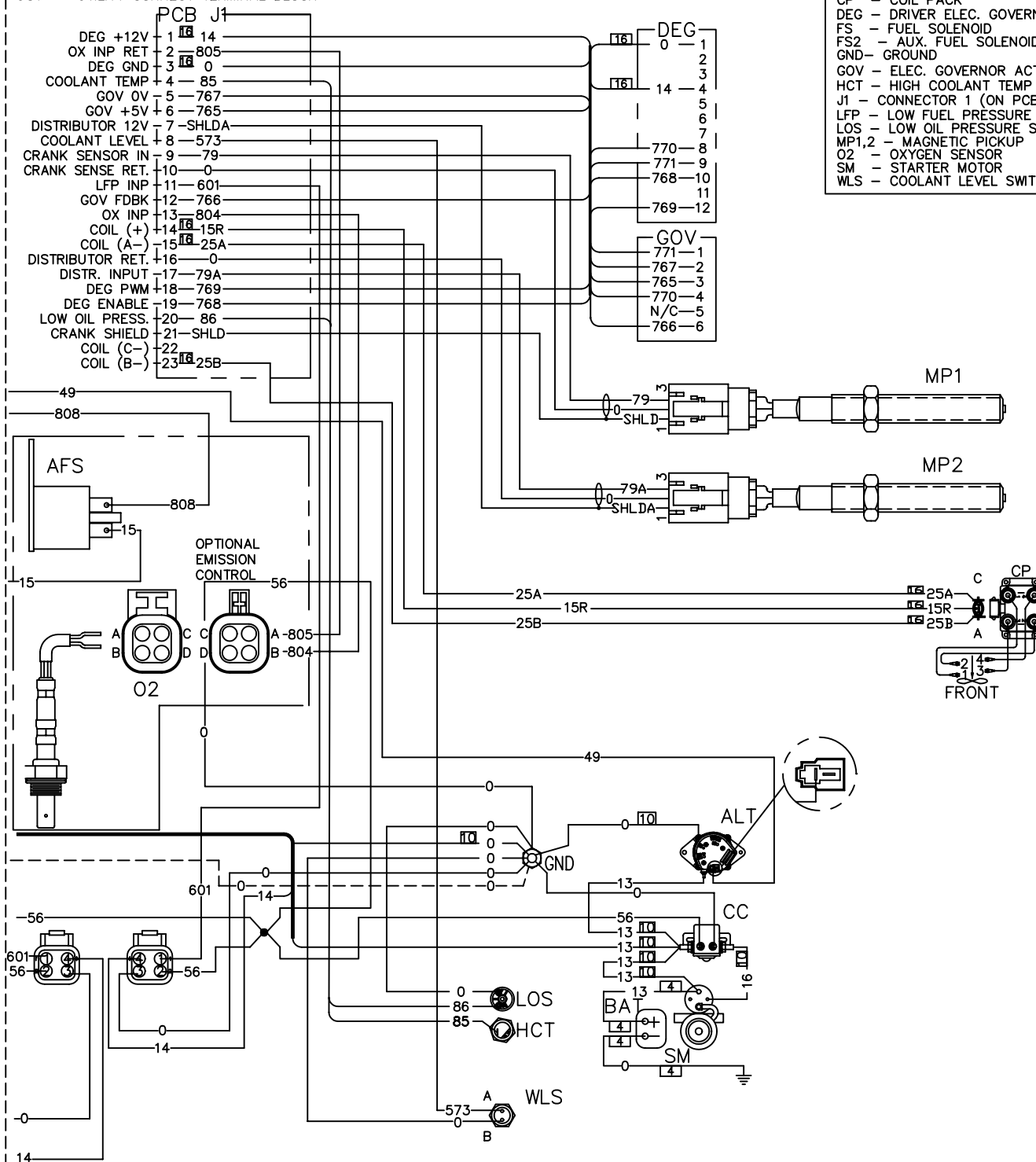

REVISION: *
DATE: 06/05/06

GROUP G

CONTROL PANEL LEGEND

- AVR - AUTOMATIC VOLTAGE REGULATOR
- BCH - BATTERY CHARGER
- BR1 - BRIDGE RECTIFIER
- CB2 - CIRCUIT BREAKER (EXCITATION)
- F1 - FUSE, BAT POWER (15A ATO TYPE)
- J2 - CONNECTOR 2 (ON PCB)
- MOV - VARISTOR 680V
- R4 - FIELD BOOST RESISTOR
- RL1 - RELAY 1 (START RELAY)
- RL2 - RELAY 2 (ENGINE RUN)
- SW1 - AUTO/OFF/MANUAL SWITCH
- SW2 - SET EXERCISER SWITCH
- TR1 - TRANSFORMER (6VA UTIL/16 VAC)

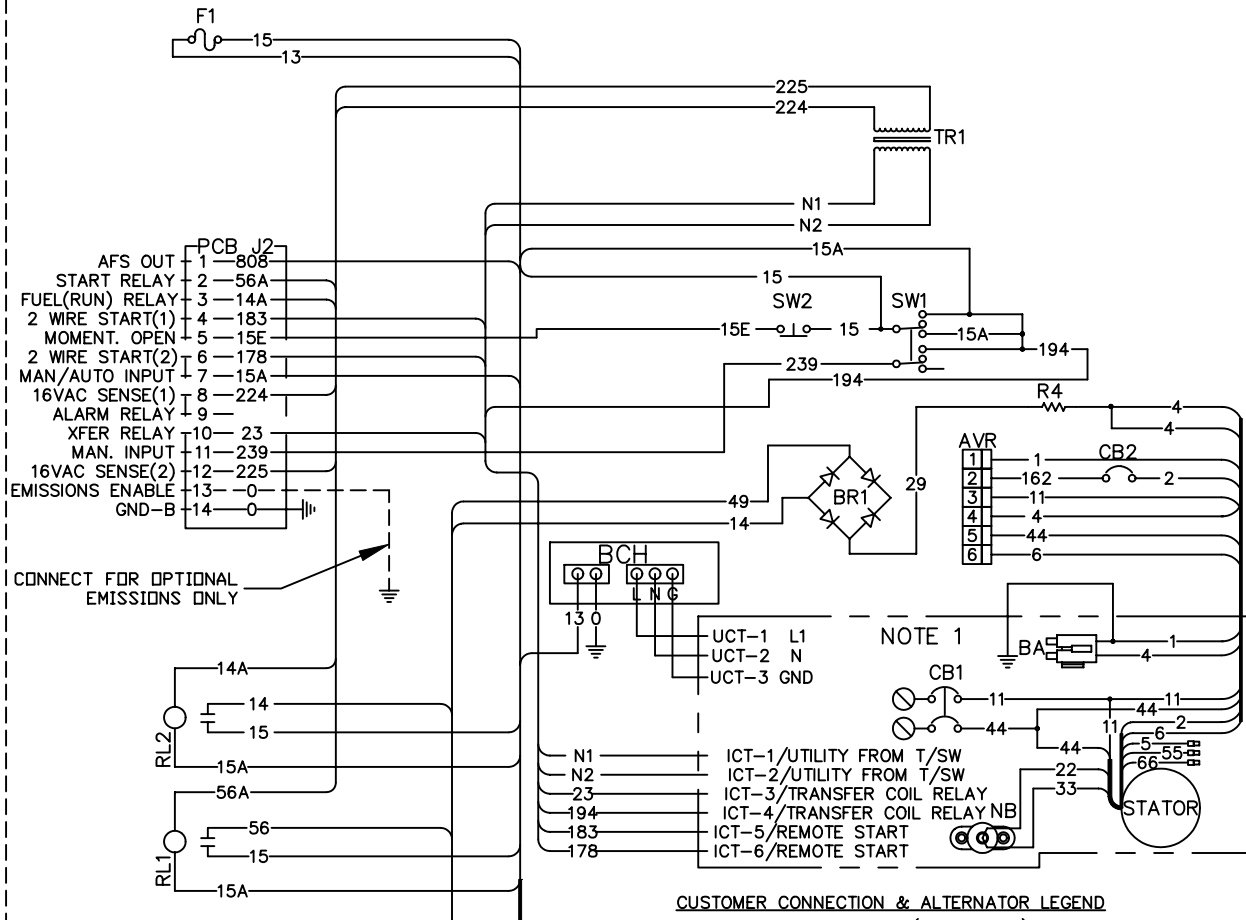

NOTE 1: WIRING SHOWN FOR CB1, NB, BA AND STATOR IS TYPICAL FOR SINGLE PHASE. FOR 3-PHASE, SEE DWG. 0F6839.

CUSTOMER CONNECTION & ALTERNATOR LEGEND

- BA - BRUSH ASSEMBLY (GENERATOR)
- CB1 - MAINLINE CIRCUIT BREAKER
- ICT - INTERCONNECT TERMINAL BLOCK
- NB - NEUTRAL BLOCK
- UCT - UTILITY CONNECT TERMINAL BLOCK

REVISION: *
DATE: 06/06/06

PAGE 1 OF 2

SCHMATIC - DIAGRAM
2.4L 4 POLE
DRAWING #: 0G2204

GROUP G

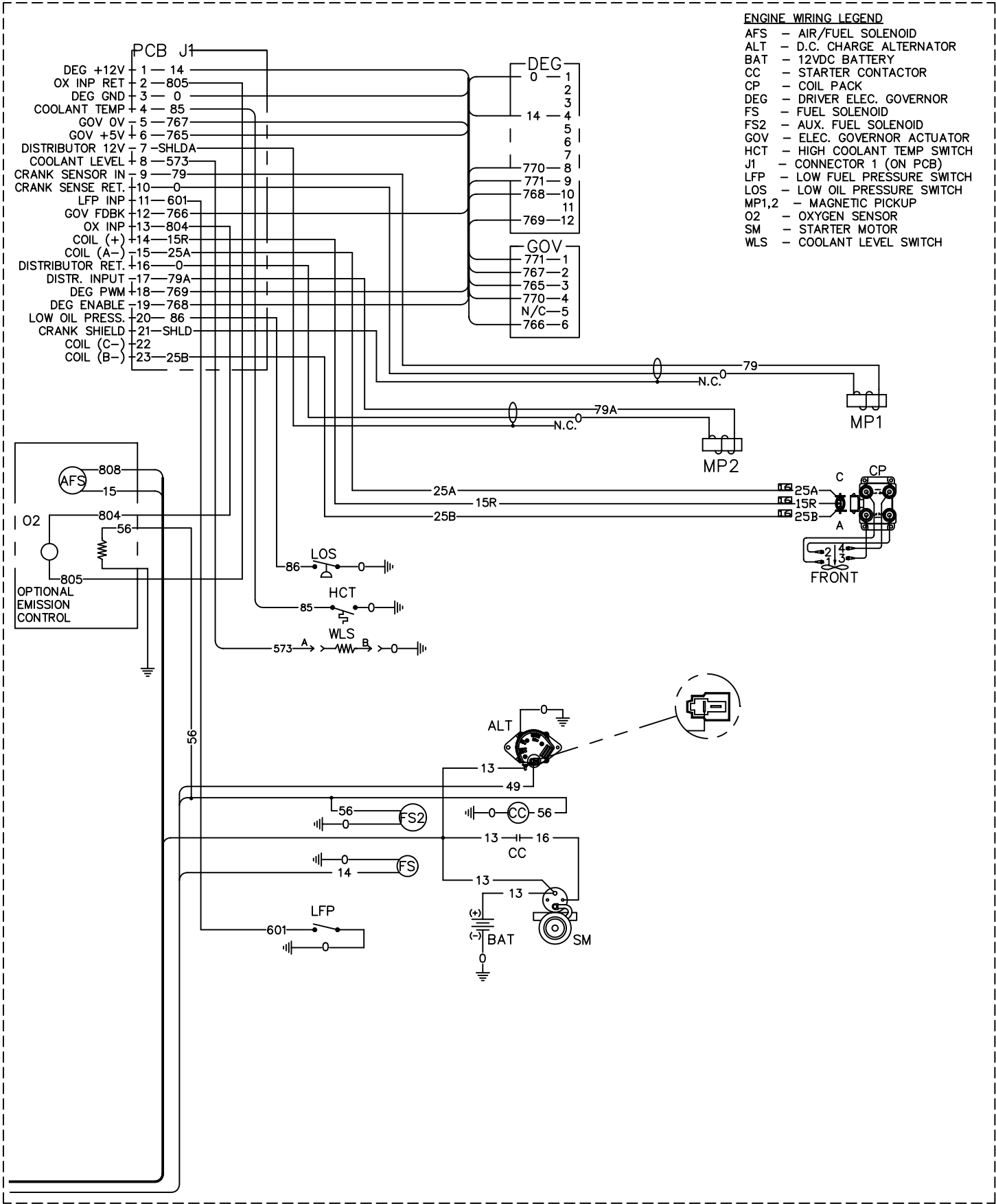

SCHEMATIC - DIAGRAM

2.4L 4 POLE

DRAWING #: 0G2204

REVISION: *
DATE: 06/06/06

GROUP H

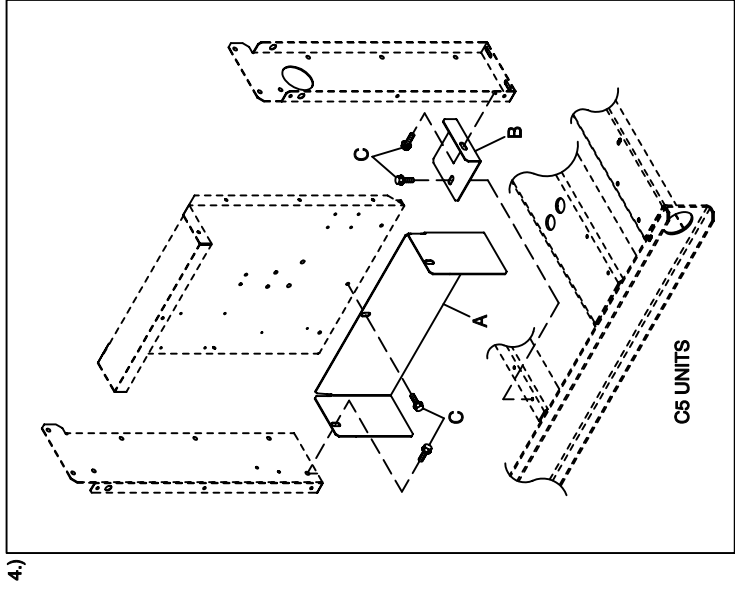
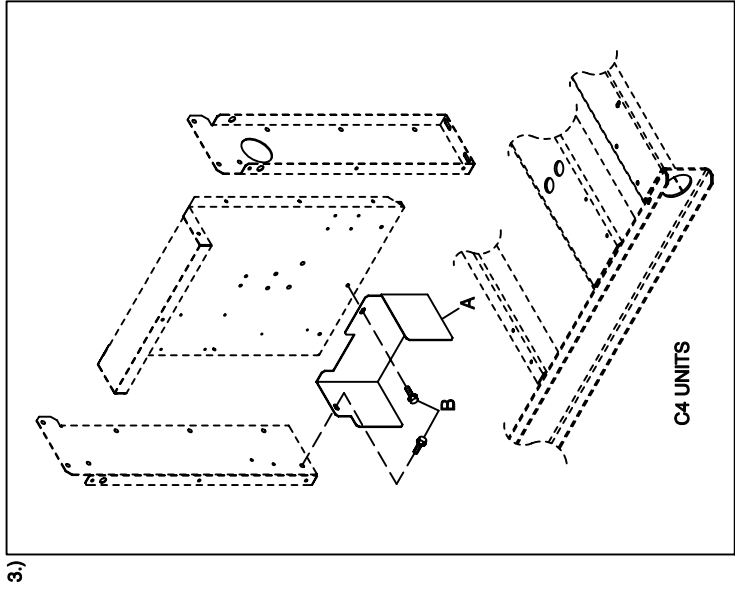
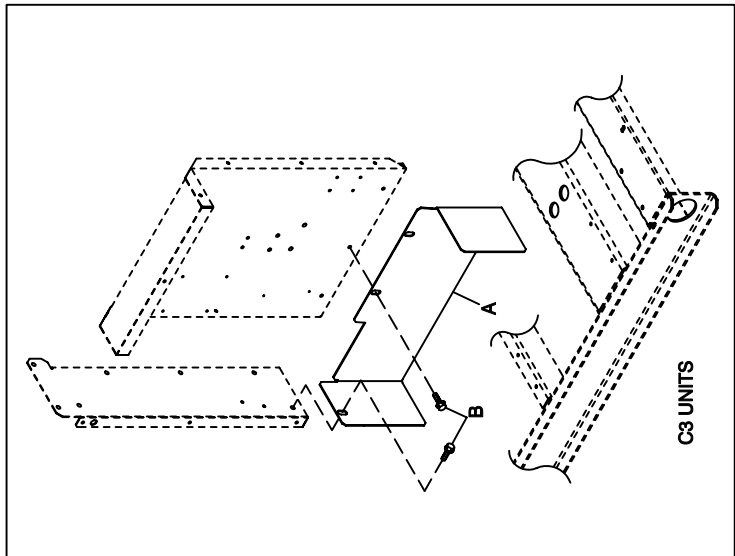
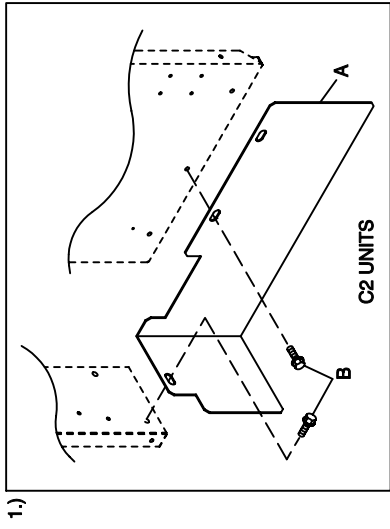

**EXPLODED VIEW: C4 CB CONNECTION BOX SHIELDING C2/C4
DRAWING #: 0G0258D**

GROUP H

APPLICABLE TO:

ITEM	PART #	QTY.	DESCRIPTION
1.)	C2 UNITS		
A	0F9832	1	SHIELD CONN BOX C2
	0F9832GGSOR	1	SHIELD CONTROL STAND C2
B	0C2454	3	SCREW THF M6-1 X 16 N WA Z/JS
2.)	C3 UNITS		
A	0F9832B	1	SHIELD CONTROL STAND C3
	0F9832KGSOR	1	SHIELD CONTROL STAND C3
B	0C2454	3	SCREW THF M6-1 X 16 N WA Z/JS
3.)	C4 UNITS		
A	0F9832A	1	SHIELD CONTROL STAND C4
B	0C2454	2	SCREW THF M6-1 X 16 N WA Z/JS
4.)	C5 UNITS		
A	0F9832C	1	SHIELD CONTROL STAND C5
	0F9832D	1	SHIELD CONTROL STAND C5
	0F9832EGSOR	1	SHIELD CONTROL STAND C5
	0F9832HGSOR	1	SHIELD CONTROL STAND C5
	0F9832JGSOR	1	SHIELD CONTROL STAND C5
B	0F9832FGSOR	1	SHIELD CONTROL STAND C5
C	0C2464	3	SCREW THF M6-1 X 16 N WA Z/JS

Free Manuals Download Website

<http://myh66.com>

<http://usermanuals.us>

<http://www.somanuals.com>

<http://www.4manuals.cc>

<http://www.manual-lib.com>

<http://www.404manual.com>

<http://www.luxmanual.com>

<http://aubethermostatmanual.com>

Golf course search by state

<http://golfingnear.com>

Email search by domain

<http://emailbydomain.com>

Auto manuals search

<http://auto.somanuals.com>

TV manuals search

<http://tv.somanuals.com>