

# OWNER'S Manual

---

Series NP-75D

## LIQUID-COOLED RECREATIONAL VEHICLE GENERATOR

Model No. 9344-2

**GENERAC**<sup>®</sup>  

---

**POWER SYSTEMS, INC.**

# GENERAL SAFETY RULES

**THE MANUFACTURER SUGGESTS THAT THESE "RULES" FOR SAFE OPERATION BE COPIED AND POSTED IN POTENTIAL HAZARD AREAS OF THE RECREATIONAL VEHICLE. SAFETY SHOULD BE STRESSED TO ALL OPERATORS AND POTENTIAL OPERATORS OF THIS EQUIPMENT.**

Study these SAFETY RULES carefully before operating or servicing applicable equipment. Become familiar with this Owner's Manual and with your generator. Safe, efficient and reliable operation can only be achieved if generator is properly installed, operated and maintained. Many accidents are caused by failing to follow simple and fundamental rules or precautions. The manufacturer suggests that these GENERAL SAFETY RULES be copied and posted in potential hazard areas of the recreational vehicle. Safety should be stressed to all operators and potential operators of equipment.









## WARNING:



The engine exhaust from this product contains chemicals known to the State of California to cause cancer, birth defects, or other reproductive harm.

The manufacturer cannot possibly anticipate every circumstance that might involve a hazard. The warnings in this Manual and on tags and decals affixed to the unit are, therefore, not all-inclusive. If you use a procedure, work method or operating technique Generac does not specifically recommend, you must satisfy yourself that it is safe for you and others. You must also make sure the procedure, work method or operating technique that you chose does not render the generator to be unsafe.

-  For fire safety, the recreational vehicle generator must be properly installed and maintained. Installation must always remain in compliance with applicable codes and standards. In addition, the generator must be installed in conformance to the manufacturer's detailed installation instructions. Following installation, nothing must be done that might render the generator in noncompliance with such codes, standards and instructions.
-  The RV generator produces extremely high and dangerous electrical voltages and can cause dangerous, and possibly fatal, electrical shock. Avoid contact with bare wires, terminals, etc. while the unit is running. If you must work around an operating generator, stand on an insulated, dry surface to reduce shock hazard.
- Never work on this equipment or handle any electrical device while standing in water, while barefoot, or while hands or feet are wet. Dangerous electrical shock will result.
- Have the generator properly grounded (bonded) during installation into the vehicle, either by solid mounting to the vehicle frame or chassis or by means of an approved bonding conductor. DO NOT disconnect the bonding conductor, if so equipped. DO NOT reconnect the bonding conductor to any generator part that might be removed or disassembled during routine maintenance. If the grounding conductor must be replaced, use only a flexible conductor that is of No. 8 AWG copper wire minimum.
- In case of accident caused by electric shock, shut down the source of electrical power down at once. If this cannot be done, free victim from live conductor. AVOID DIRECT CONTACT WITH THE VICTIM. Use a dry board, dry rope, or other non-conducting implement to free the victim from live conductor.
-  Inspect fuel system frequently for leaks or damage. Repair or replace any damaged or leaking component immediately. Never attempt to change, alter or modify the generator fuel system in any way that might affect safety or compliance with applicable codes and standards.
- The generator engine gives off DEADLY carbon monoxide gas through its exhaust system. This dangerous gas, if breathed in sufficient concentrations, can cause unconsciousness or even death. This exhaust system must have been properly installed, in strict compliance with applicable codes and standards. Following installation, you must do nothing that might render the system unsafe or in non-compliance with such codes and standards. The generator compartment must be completely vapor sealed from vehicle interior. There must be no possibility of exhaust fumes entering the vehicle interior. Never operate this equipment with a leaking or defective exhaust system.
- Never use the generator or any of its parts as a step. Stepping on the unit can stress and break parts and may result in dangerous, fuel leakage, oil leakage, etc.
-  Do not smoke around the generator. Wipe up any fuel and oil spills immediately. Never leave oily or fuel soaked rags in the generator compartment or on the generator itself. Keep the area around the generator clean and free of debris.
-  Adequate ventilation is required to expel toxic fumes and gasoline vapors from the generator compartment. Do not alter the installation of this equipment in any manner that might obstruct air and ventilation openings. Such openings must be kept clear and unobstructed.
- Keep hands, feet, clothing, etc., away from drive belts, fans and other moving parts of this equipment. Never remove any drive belt or fan guards while the unit is operating.
- Inspect the generator periodically. Repair or replace all damaged or defective parts immediately.
-  These generators can be converted to use LP gas (propane) as a fuel. LP gas is highly EXPLOSIVE. The gas is heavier than air and tends to settle in low areas where even the slightest spark can ignite the gas and cause an explosion.
-  Before performing any maintenance on the generator set, disconnect its battery cables to prevent accidental start up. Disconnect the cable from the battery post indicated by a NEGATIVE, NEG or (-) first. Reconnect that cable last.

# IDENTIFICATION RECORD AND GENERATOR FEATURES

Please record the following information from the generator DATA DECAL or information decal.

- |                       |                        |
|-----------------------|------------------------|
| 1. Model Number _____ | 2. Serial Number _____ |
| 3. kW Rating _____    | 4. Rated Voltage _____ |
| 5. Phase _____        | 6. Hertz _____         |

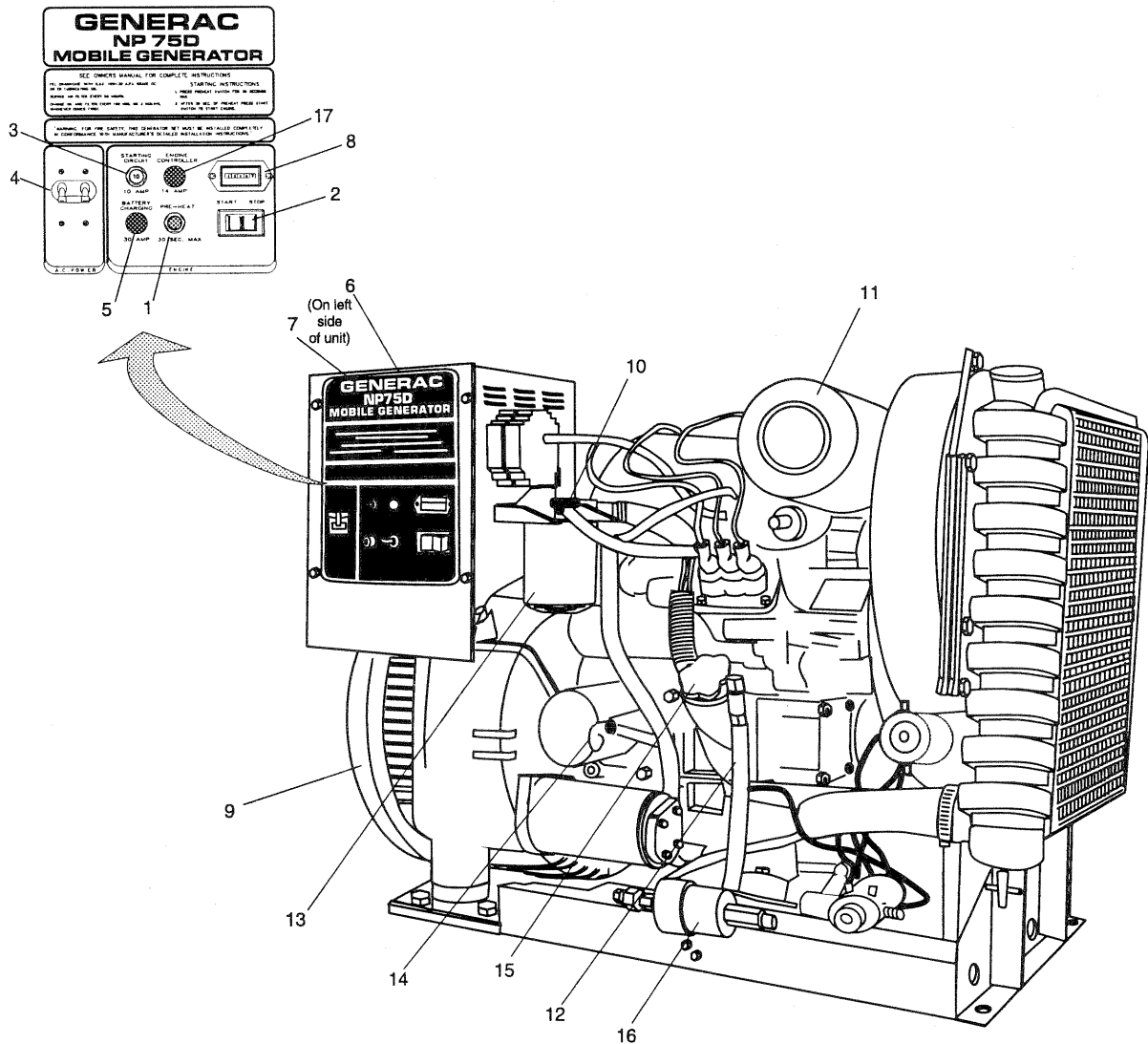

## REFERENCE NUMBER IDENTIFICATION

- |                                 |                                |
|---------------------------------|--------------------------------|
| 1. Engine Pre-heat Switch       | 10. Fuel Return Connection     |
| 2. Engine Start/Stop Switch     | 11. Air Cleaner                |
| 3. 10 amp DC Circuit Breaker    | 12. Oil Drain Hose             |
| 4. 35 amp AC Circuit Breaker    | 13. Oil Filter                 |
| 5. 30 amp Battery Charging Fuse | 14. Oil Dipstick               |
| 6. Generator AC Output Leads    | 15. Oil Filler Opening and Cap |
| 7. Remote Leads                 | 16. Fuel Filter                |
| 8. Hourmeter                    | 17. 14 amp Fuse                |
| 9. Generator                    |                                |

# TABLE OF CONTENTS

---

## OPERATING INSTRUCTIONS

GENERAL SAFETY RULES .....inside cover

IDENTIFICATION RECORD AND  
GENERATOR FEATURES..... 1

### READ THIS MANUAL THOROUGHLY

Operation and Maintenance ..... 3  
How to Obtain Service ..... 3  
Service Dealer Location ..... 3

### GENERATOR FAMILIARIZATION

Generator Applicability ..... 4  
Installation ..... 4  
Safety ..... 4  
Generator AC Connection System ..... 4

### OPERATING INSTRUCTIONS

Generator Control Panel..... 5  
• Hourmeter ..... 5  
• Engine Start/Stop Switch..... 5  
• 10-amp Circuit Breaker ..... 5  
• Dual AC Circuit Breaker ..... 5  
• Preheat Switch ..... 5  
Remote Start/Stop Panel..... 5  
Before Start-up ..... 5  
Start the Generator..... 6  
Shutting Down the Generator ..... 6

### ADDITIONAL INFORMATION

Automatic Low Oil Pressure Shutdown ..... 7  
High Coolant Temperature Shutdown ..... 7  
Overspeed Shutdown ..... 7  
Engine Governed Speed ..... 7  
25-Hour Break-in Period..... 7  
25-Hour Check-up Period..... 8  
Freezing Temperature Operation ..... 8  
Attention Required After Submersion ..... 8  
Operating Precautions..... 8  
Effects of Moisture and Dirt ..... 8

## SPECIFICATIONS

Fuel Requirements ..... 9  
Recommended Fluids..... 9  
Generator Specifications ..... 9  
Engine Specifications ..... 9

## MAINTENANCE

Periodic Maintenance Schedule ..... 10  
Overload Protection for Engine DC Elec. System ..... 10  
• 10 amp Circuit Breaker..... 10  
• 14 amp Fuse ..... 10  
• 30 amp Fuse ..... 10  
Checking Fluid Levels ..... 11  
• Check Engine Oil..... 11  
• Battery Fluid ..... 11  
• Engine Coolant..... 11  
Inspect Generator Set ..... 11  
Inspect Cooling System..... 11  
Changing Engine Oil..... 11  
Coolant Change..... 12  
Miscellaneous Maintenance ..... 12  
• Cleaning the Generator ..... 12  
• Battery ..... 12  
Periodic Replacement Parts ..... 12

TROUBLESHOOTING ..... 13

ELECTRICAL DATA ..... 14

EXPLODED VIEWS AND REPAIR PARTS ..... 16

WARRANTIES.....36

# READ THIS MANUAL THOROUGHLY

If you don't understand any portion of this manual, contact Generac for a demonstration of actual starting, operating and servicing procedures.

Throughout this publication and on tags and decals affixed to the generator, DANGER, WARNING, CAUTION and NOTE blocks are used to alert you to special instruction about a particular operation that may be hazardous if performed incorrectly or carelessly. Observe them carefully.

These safety warnings cannot eliminate the hazards that they indicate. Strict compliance with the special instructions while performing the service plus "common sense" are major measures to prevent accidents.

The following definitions apply to DANGER WARNING, CAUTION and NOTE blocks found throughout the manual.



**DANGER:** Indicates an immediately hazardous situation which, if not avoided, will result in death or serious injury. Danger is limited to the most extreme situations.



**WARNING:** Indicates a potentially hazardous situation which, if not avoided, could result in death or serious injury.



**CAUTION:** Indicates a potentially hazardous situation which, if not avoided, may result in minor or moderate injury. Caution may also be used to alert against unsafe practices.

**NOTE:** Indicates a statement of company policy as the message relates directly or indirectly to the safety of personnel or protection of property.

These symbols indicate the following:



Points out important safety information and, if not followed, could endanger personal safety and/or property of yourself and others.



Potential explosion hazard



Potential fire hazard



Potential electrical shock hazard

The operator (driver) is responsible for proper and safe use of the vehicle, equipment on the vehicle, and the safety of all vehicle occupants. We strongly recommend that the operator read this Owner's Manual and thoroughly understand all instructions before using this equipment. We also strongly recommend instructing other occupants in the vehicle to properly start and operate the generator. This prepares them if they need to operate the equipment in an emergency.

## OPERATION AND MAINTENANCE

It is the operator's responsibility to perform all safety checks; to make sure that all maintenance for safe operation is performed promptly; and to have the equipment checked by an Authorized Dealer periodically. Normal maintenance service and replacement of parts are the responsibility of the Owner/Operator and, as such, are not considered defects in materials or workmanship within the terms of the warranty. Individual operating habits and usage contribute to the need for maintenance service.

Proper maintenance and care of your recreational vehicle generator assures a minimum number of problems and keeps your operating expenses at a minimum. See your authorized Dealer/Distributor for service aids and accessories.

## HOW TO OBTAIN SERVICE

When your recreational vehicle generator set requires servicing or repairs, simply contact an Authorized Service Facility for assistance. Service technicians are factory-trained and are capable of handling all of your service needs.

When contacting an Authorized Service Facility or the factory about parts and service, always supply the complete model number and serial number of your unit as given on its data plate.

The warranty on your generator is included in this Owner's Manual, as well as listings for repair parts.

## SERVICE DEALER LOCATION

TO LOCATE THE NEAREST GENERAC SERVICING DEALER, PLEASE CALL OUR 800 NUMBER.

ONLY DEALER LOCATION INFORMATION CAN BE OBTAINED AT THIS NUMBER.

**1-800-333-1322**

# GENERATOR FAMILIARIZATION

## GENERATOR APPLICABILITY

These generators have been designed and manufactured for supplying electrical power for recreational vehicles. You should not modify the generator or use it for any application other than for what it was designed. If there are questions pertaining to its application, write or call the factory. Do not use the unit until you have been advised by a competent authority.



**DANGER:** For fire safety, the generator must have been properly installed in compliance with (1) ANSI 119.2-1975/NFPA 501C-1994 "Standard for Recreational Vehicles", Part III, "Installation of Electrical Systems." The generator also must have been installed in strict compliance with the manufacturer's detailed installation instructions. After installation, do nothing that might render the unit in non-compliance with such codes, standards and instructions.

You can use this generator to supply electrical power for operating 120/240 volts, single phase, 60 Hertz, AC electrical loads requiring up to 7,500 watts (7.5 kW) of power. Those electrical loads cannot exceed 62.5 AC amperes of current at 120 volts, or 31.2 AC amperes at 240 volts.



**CAUTION:** Do not overload the generator. Some installations may require that electrical loads be alternated to avoid overloading. Applying excessively high electrical loads may damage the generator and may shorten its life. Add up the rated watts of all electrical lighting, appliance, tool and motor loads the generator will power at one time. This total should not be greater than the wattage capacity of the generator. If an electrical device nameplate gives only volts and amps, multiply volts times amps to obtain watts (volts x amps = watts). Some electric motors require more watts of power (or amps of current) for starting than for continuous operation.

## INSTALLATION

This Owner's Manual has been prepared assuming that competent, qualified technicians installed the generators into recreational vehicles. We also assume installer complied with all applicable codes, standards and regulations pertaining to installation.

An INSTALLATION MANUAL was shipped with the generator. That manual contains manufacturer's instructions and recommendations for installing the unit into a recreational vehicle. Following installation, installers should forward the Installation Manual to Owner/Operators for their information.

Owners/Operators have the responsibility to make sure that nothing is done that might render installation unsafe or so it will not comply with applicable codes, standards and instructions.

## SAFETY

Before attempting to use the generator set, carefully read GENERAL SAFETY RULES inside the cover of this Manual. Comply strictly with these RULES to prevent accidents and damage to equipment and/or property. Generac suggests that copying and posting GENERAL SAFETY RULES in potential hazard areas of the vehicle. Stress safety to all operators and potential operators of this equipment.

## GENERATOR AC CONNECTION SYSTEM

The generator is equipped with a dual stator AC power windings. These two stator windings supply electrical power to customer electrical loads by means of a dual 2-wire connection system. Note, however, the neutral is grounded.

The generator has been installed so that units power 120/240 volts AC loads (Figure 1); or you can rewire them to connect only 120 volts AC electrical loads. Be sure to add jumper wire between circuit breakers (C.B. in Figure 2) when connecting for 120 volts.

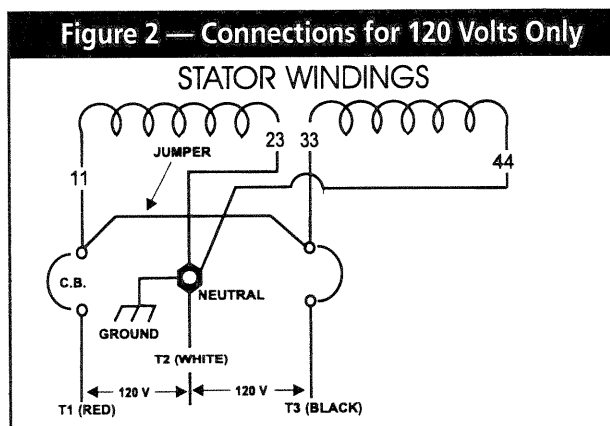
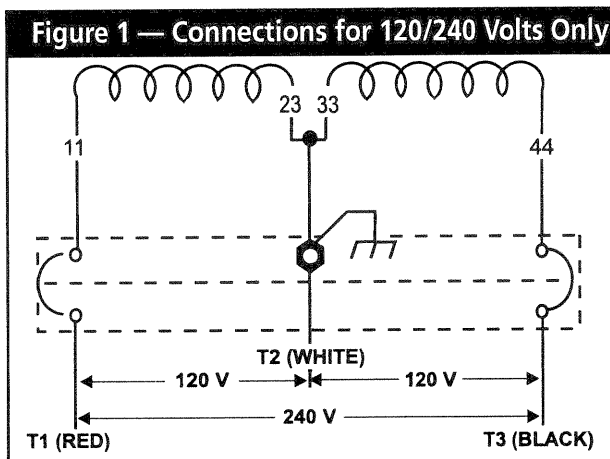

# OPERATING INSTRUCTIONS

## GENERATOR CONTROL PANEL

See Figure 3 to identify the following components:

### ■ HOURMETER

Provides continuous indication of engine operating time, in hours and tenths of hours. Use the hourmeter with the periodic maintenance tasks are completed on a timely basis.

### ■ ENGINE START/STOP SWITCH

To crank and start the engine, hold switch at its START position. Release the switch when the engine starts. To stop an operating engine, press and hold the switch in its STOP position until the engine shuts off. The switch center position is the RUN position.

### ■ 10-AMP CIRCUIT BREAKER

Protects the DC control circuit against electrical overload. If the fuse element has melted open due to overloading, the engine cannot be cranked, engine preheat and start functions cannot occur. The breaker is a "push to reset" type.

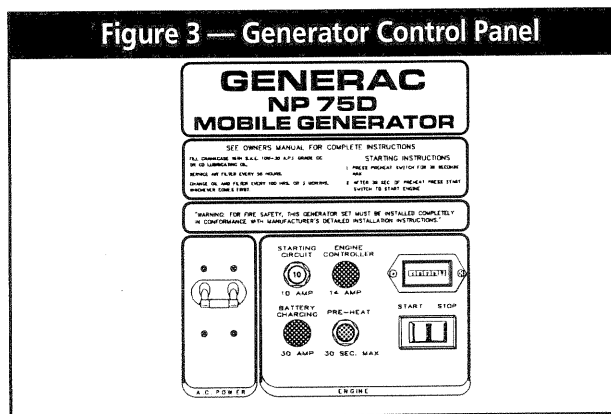

### ■ DUAL AC CIRCUIT BREAKER

Rated at 35 AC amps, the circuit breaker (Figure 4) protects the generator's AC output circuit against overload and provides a method of turning OFF the generator's 120/240 volts AC output to vehicle circuits.

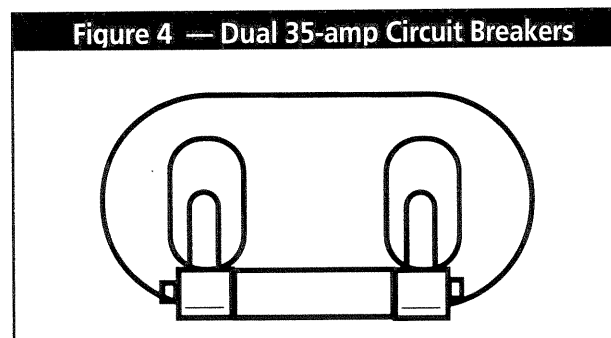

### ■ PREHEAT SWITCH

The diesel engine is equipped with glow plugs, one for each cylinder. When you press the preheat switch (Figure 3), the glow plugs heat the engine combustion chamber for quicker starts in cold weather. To preheat the combustion chamber for quicker starts in cold weather. Press the switch between 15 and 30 seconds. Continue holding in the preheat switch while cranking the engine until it starts.

**NOTE:** Refer to THE GENERATOR AC CONNECTION SYSTEM on Page 4. Individual installations will differ. If an overload occurs, the dual breakers will open the hot stator leads (11 and 44). When the generator has been connected for 120 volts only, one of the dual circuit breakers will open stator AC output lead No. 11 (hot lead).

## REMOTE START/STOP PANEL

A remote mounted Start/Stop Panel (model #9044) is available, which allows you to start and stop the generator engine conveniently from inside the vehicle (Figure 5).

You can also order a remote panel (model #9061) that includes meters and gauges for monitoring low oil pressure, high coolant temperature and low coolant level, in addition to a start/stop switch. The panel also includes an ammeter, a voltmeter and an hourmeter.

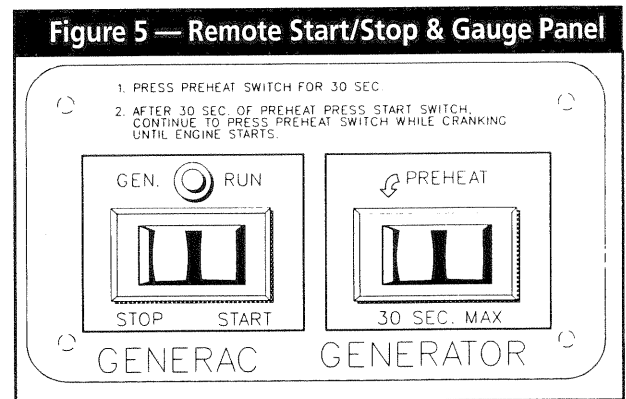

## BEFORE START-UP

- **Check Engine Crankcase Oil Level:** Refer to SPECIFICATIONS and MAINTENANCE sections for procedures and recommendations.

**CAUTION!** Any attempt to crank or start the engine before properly servicing it with recommended oil will result in an engine failure.

**NOTE:** Engine was factory serviced with a high quality oil classified "For Service CD" or "For Service CC" and having a viscosity rating of SAE 30. The installer may have refilled the crankcase with an oil more suitable for ambient temperature ranges in your area.

- **Check Coolant Level:** Check coolant level prior to initial use and at recommended intervals. Refer to SPECIFICATIONS and MAINTENANCE sections for procedures and recommendations.
- **Check Fuel Supply:** Make sure an adequate supply of clean fuel is available to the engine. Many installations include a Fuel Shutoff Valve, which you must open before starting the engine.

**NOTE:** On some installations, the generator may have been provided with its own fuel tank. On other installations, the generator may “share” with the vehicle’s fuel tank. When the vehicle’s tank is shared, some installers may have installed a generator fuel pick up tube in the shared tank that is shorter than the vehicle’s pick up tube. When a shorter generator fuel pick up tube is installed in the tank, the generator will run out of gas while sufficient fuel remains in the tank for vehicle engine operation.

## START THE GENERATOR

To start the generator from either the generator control panel or from the optional Remote Panel, proceed as follows:

1. Turn OFF electrical loads, using whatever means provided.

**NOTE:** If starting from the generator panel, turn OFF loads by setting the generator’s main circuit breaker to OFF or OPEN. If starting from a Remote Panel, turn OFF loads using whatever means is provided in the vehicle (such as a main circuit breaker.)

2. Press the preheat switch (if engine is cold) for between 15 and 30 seconds.
3. At the same time, hold the Engine-Start/Stop Switch at START and press the preheat switch to crank engine. Release the switches when the engine starts.
4. Let the engine stabilize and warm up.
5. Turn ON electrical loads, using whatever means provided.

## SHUTTING DOWN THE GENERATOR

1. Turn OFF electrical loads, using whatever means provided.
2. Let the engine run at no-load for a few minutes to stabilize internal temperatures.
3. Set the Engine-Run/Stop Switch to STOP position.



## AUTOMATIC LOW OIL PRESSURE SHUTDOWN

The engine is equipped with a normally-closed (N.C.) oil pressure switch (Figure 6). Engine oil pressure holds the switch open during cranking and operation. Should oil pressure drop below about 10 psi, the switch contacts close and the engine automatically shuts down.

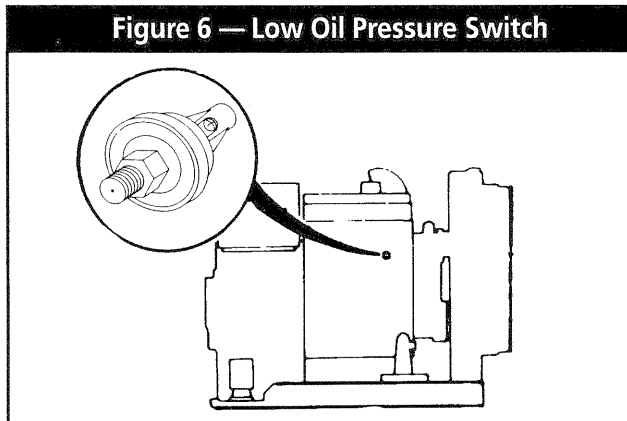

## HIGH COOLANT TEMPERATURE SHUTDOWN

This switch (Figure 7) is a normally open (N.O.) thermostatic device which is immersed in engine coolant. Should engine coolant temperature exceed about 250°F (121°C), the switch contacts close and the engine shuts down.

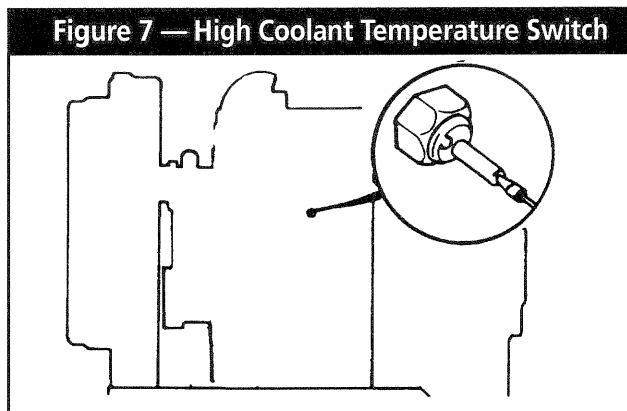

## OVERSPEED SHUTDOWN

The generator control panel houses an Engine Controller circuit board (Figure 8). That circuit board receives AC frequency signals from generator stator leads 11 and 22. Should AC frequency exceed about 72 Hz (2160 rpm), circuit board action initiates an automatic shutdown after a few seconds.

Figure 8 — Engine Controller Circuit Board

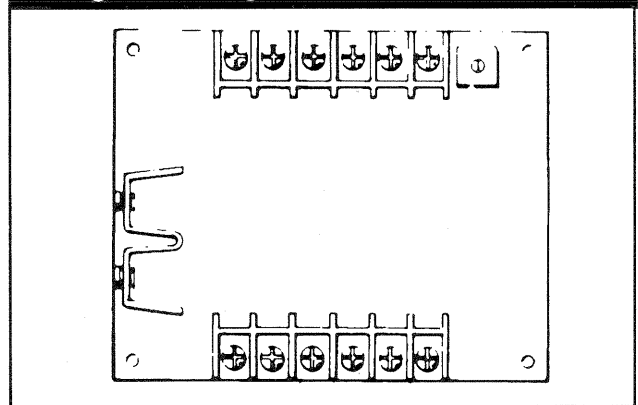

**NOTE:** After an overspeed shutdown, the engine may be cranked and re-started. However, if the engine overspeeds again, the engine will shut down again.

## ENGINE GOVERNED SPEED

The generator is equipped with a 4-pole revolving field (rotor) which must be driven at 1800 rpm to produce the unit's rated AC frequency of 60 Hz. The diesel engine governor was factory set to about 62 Hz. (1860) at no-load. After installing it, the installation technician should check and adjust the governed speed. Setting the no-load frequency slightly high helps prevent excessive frequency, rpm and voltage drop under heavy electrical loading.



**DANGER:** Do not tamper with the engine governor settings. Excessively high engine speeds are dangerous and increase the risk of personal injury and damage to equipment an/or property. Excessively low speeds impose a heavy load on the engine when adequate engine power is not available and may shorten engine life. The generator supplies correct rated frequency and voltage only at the proper speed. Some electrical devices may be damaged by incorrect frequency and/or voltage. If engine speed appears to be incorrect, contact your nearest authorized service facility.

## 25-HOUR BREAK-IN PERIOD

The first 25 hours of operation is the break-in period for the generator. Properly breaking in the generator is essential to reducing oil consumption and enhancing engine performance. During the break-in period, observe the following rules:

- For the first 25 hours, run the generator at varying electrical loads, to help set the engine piston rings properly.

## ADDITIONAL INFORMATION

---

- Following the initial 25-hour break-in period, avoid light electrical loads for the next 75 hours of operation. The unit should be loaded at 50% (or more) of its capacity during those 75 hours. Repeated light loads during break-in period may improperly seat the piston rings, resulting in blowby and high oil consumption.
- Check oil level frequently during the break-in period. Add oil if needed. It is natural for the generator engine to consume much oil until the piston rings have seated properly.
- When the 25-hour break-in period is done, complete the tasks recommended under 25-HOUR CHECK-UP PERIOD.

### 25-HOUR CHECK-UP PERIOD

After the first 25 hours of operation have been completed, contact an Authorized Service Facility for the following maintenance. The Owner/Operator is responsible for any changes.

- Change engine crankcase oil and oil filter.
- Check all fluid levels.
- Check all cooling system hoses and fittings for damage, deterioration, looseness, etc. Check all hose clamps for tightness and security.
- Check engine for proper operation.
- Inspect the diesel engine fuel system for leaks, tightness and security of fuel fittings and hoses.
- Inspect V-belts for condition and proper tension.
- Inspect the exhaust system for damage, deterioration, leaks proper operation.
- Inspect the electrical system.
- Inspect the installation for safety violations, compliance with codes and standards.

### FREEZING TEMPERATURE OPERATION

The engine cooling system should have been properly filled with a 50-50 mixture of low silicate, ethylene glycol base antifreeze and soft water. When adding coolant to the radiator or to the coolant recovery bottle, add only the recommended 50-50 mixture. Refer to SPECIFICATIONS section. If the recommended 50-50 mixture is added to the system consistently, the unit adequately protect against freezing temperatures.

### ATTENTION REQUIRED AFTER SUBMERSION

If the generator has been submerged in water, it must NOT be started and operated. Following any submersion in water, have an authorized Generac Service Facility thoroughly clean and dry the generator.

### OPERATING PRECAUTIONS

Never operate the generator set while the vehicle is parked over dry leaves, dry grass or any other combustible substance. The generator's exhaust system becomes extremely hot and can cause fire if it is too close to combustible materials.

The generator's exhaust system gives off deadly carbon monoxide gas. This dangerous gas, if breathed in sufficient concentrations can cause unconsciousness and even death. Never operate the generator set with the vehicle inside any garage or other enclosed area. Never operate the generator with a leaking exhaust system. Close windows in the vicinity of the generator exhaust outlet and take any other steps that may be necessary to prevent exhaust gases from entering rooms or areas occupied by people or animals.

### EFFECTS OF MOISTURE AND DIRT

Keep the generator set as clean and dry as possible. Protect the unit against excessive dust, dirt, corrosive vapors, road splash, etc. Permitting dirt and moisture to accumulate on generator windings will have an adverse affect on the insulation resistance of those windings.

When moisture is allowed to remain in contact with windings, some of that moisture will be retained in voids and cracks in the insulation. This causes a reduced insulation resistance and will eventually cause problems. Dirt will make the problem worse, since dirt tends to hold moisture in contact with the windings. Salt (as from sea air) will also worsen the problem since it tends to absorb moisture from the air. Salt and moisture, when combined, form a good electrical conductor.

# SPECIFICATIONS

## FUEL REQUIREMENTS

Recommended fuel is any high quality, automotive type diesel fuel conforming to JIS No. 2D diesel fuel. Keep the fuel clean.

## RECOMMENDED FLUIDS

**Engine Oil:** Use a high quality detergent oil classified "For Service CC or CD" Detergent oils keep the engine cleaner and reduce carbon deposits. Use oil having the following SAE viscosity rating, based on the ambient temperature range anticipated before the next oil change:

Temperature	Oil Grade (recommended)
above 100°F	SAE 40
40°-100°F	SAE 10W-30 or SAE 30
below 40°F	SAE 5W-20 or 5W-30

**Coolant:** Use a mixture of half low silicate, ethylene glycol base antifreeze and half soft water. Coolant system capacities may vary, depending on the specific installation, length of system hoses, radiator use, etc.. Use only soft water and low silicate antifreeze. If desired, a high quality rust inhibitor may be added to the recommended coolant mixture. When adding coolant, always add the recommended 50-50 mixture.



**CAUTION!** Do not use any chromate base rust inhibitor with ethylene glycol base antifreeze or chromium hydroxide ("green slime") forms and causes overheating. You must chemically clean engines that have operated with a chromate base inhibitor before adding ethylene glycol base antifreeze. Using any high silicate antifreeze boosters or additives will also cause overheating. In addition, using any soluble oil inhibitor is not recommended for this equipment.

## GENERATOR SPECIFICATIONS

Model .....NP-75D  
Model Number .....9344-2  
Rated Maximum Continuous  
AC Power Output .....7500 watts (7.5 kW)  
Rated Voltage .....120/240 volts AC  
Rated Maximum Continuous  
Current  
    at 120 volts .....62.5 AC amperes  
    at 240 volts .....31.2 AC amperes  
Phase .....1 Phase  
Rated AC Frequency .....60 Hz. at 1800 rpm  
Power Factor .....1.0  
Number of Rotor Poles .....4  
Rotor Speed at No-Load .....1860 rpm

## ENGINE SPECIFICATIONS

Type of Engine .....4-cycle diesel  
Cooling Method .....Water-cooled  
Displacement .....58.2 inches (954cc)  
Combustion Chamber .....Swirl Type  
Cylinders and Arrangement .....3  
Bore .....2.95 inches (75cc)  
Stroke .....2.83 inches (72cc)  
Compression Ratio .....23 to 1  
No. of Main Bearings .....5  
Break Mean  
Effective Pressure .....97

# MAINTENANCE

## PERIODIC MAINTENANCE SCHEDULE

\* Performed by Authorized Service Facility

\*\* Performed by Owner/Operator

### A. After the first 25 Operating Hours\*

1. Change oil and oil filter.
2. Check engine coolant level.
3. Inspect cooling system.
4. Check engine operation.
5. Inspect drive belts.
6. Inspect exhaust system.
7. Inspect electrical system.
8. Inspect battery.
9. Check governed speed setting.
10. Check engine valve clearance.
11. Inspect air cleaner/flame arrestor.
12. Clean the generator.

### B. Every 8 Hours of Operation\*\*

1. Check coolant level in coolant recovery bottle.
2. Check fuel level.
3. Check engine oil level.

### C. Once Each Week\*\*

1. Inspect the generator set.
2. Inspect the generator battery.

### D. Every 100 Hours or Once Each Month\*\*

(whichever comes first)

1. Inspect cooling system.
2. Inspect exhaust system.

### E. Every 6 Months or Every 250 Operating Hours\*

(whichever comes first)

1. Change engine oil and filter.
2. Check engine operation.
3. Inspect drive belts.
4. Inspect electrical system.
5. Inspect and check battery.
6. Check engine governor setting.
7. Clean or replace fuel filters.
8. Inspect air cleaner/flame arrestor.
9. Clean the generator.
10. Check cooling system and coolant level.
11. Inspect exhaust system.
12. Inspect fuel system.

### F. Once Annually or Every 500 Operating Hours\*

(whichever comes first)

1. Check engine valve clearance.
2. Check Engine compression and condition.
3. Check fuel injection timing.
4. Check-test fuel injection nozzles.

### G. Once Every Two Years\*

1. Drain, flush and refill cooling system.

## OVERLOAD PROTECTION FOR ENGINE DC ELECTRICAL SYSTEM

Engine cranking, start up and running are controlled by a solid state engine controller circuit board. Battery voltage is delivered to that circuit board via 10 amp circuit breaker and 14 amp in-line fuse. These overcurrent protection devices will open if circuit is overloaded.



**CAUTION!** If a circuit breaker opens or a fuse element melts, you should find the cause of the overload before resetting the circuit breaker or replacing the fuse.

### 10 AMP CIRCUIT BREAKER

If the circuit breaker opens due to an overload, you cannot crank or start the engine. The circuit breaker is a "push-to-reset" type. For emergency shutdown, pull the circuit breaker open. Also see "Generator Control Panel" on Page 5.

### 14 AMP FUSE

If the fuse element melts open, you cannot crank or start the engine. If you must replace the fuse, use only identical 14 amp fuse (Figure 9).

### 30 AMP FUSE

The generator set battery is charged during operation by a DC alternator, driven by the engine. This 30 amp fuse protects the charging circuit against overload. Should you need to replace the fuse, use only an identical 30 amp fuse (Figure 10).

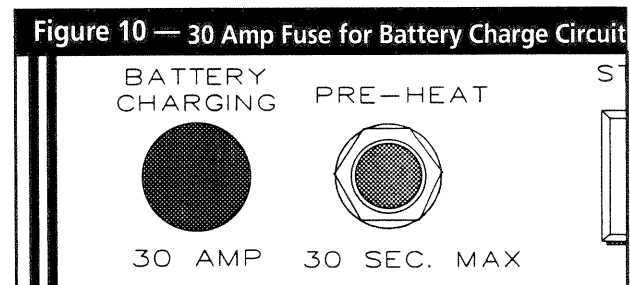
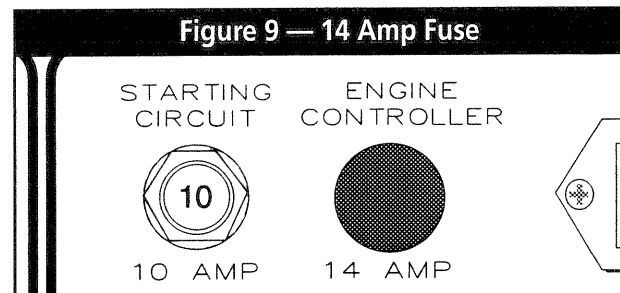

## CHECKING FLUID LEVELS

### ■ CHECK ENGINE OIL

Check the engine crankcase oil level at least every 8 hours that you operate the unit, or every time before you use it (Figure 11).

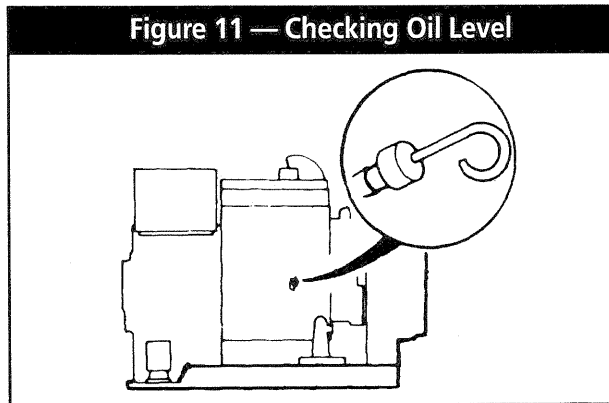

- Make sure the generator is as level as possible.
- Remove oil dipstick and wipe dry with a clean, lint free cloth.
- Install oil dipstick, then remove again.
- Oil should be at dipstick FULL mark. Never operate the generator with oil level below dipstick ADD mark. DO NOT FILL CRANKCASE ABOVE DIPSTICK FULL MARK.

### ■ BATTERY FLUID

Check battery electrolyte fluid at least once weekly. Fluid should cover separators in all battery cells. If fluid level is low, add distilled water to cover tops of separators. DO NOT USE TAP WATER IN BATTERY.

### ■ ENGINE COOLANT

Check coolant level in coolant recovery bottle.

- Add the recommended coolant mixture as necessary.
- Periodically remove radiator pressure cap to make sure the coolant recovery system is functioning properly. Coolant should be at bottom of radiator filler neck. If coolant level is low, inspect gasket in radiator pressure cap. Replace cap, if necessary. To have pressure cap tested, contact an authorized Generac Service Facility. Inspect cooling system and coolant recovery system for leaks.

## INSPECT GENERATOR SET

Once each week inspect the generator set. Look for fuel, oil and coolant leaks. Check for missing or loose nuts, bolts and other fasteners. Check for damage. If unit is dirty, it may be cleaned with a damp cloth or soft brush. Inspect the exhaust system. NEVER operate the generator with a defective exhaust.

## INSPECT COOLING SYSTEM

Inspect the entire cooling system once each month or every 100 operating hours, whichever occurs first. Check for leaks, condition of hoses, and tightness of clamps.

## CHANGING ENGINE OIL

Refer to PERIODIC MAINTENANCE SCHEDULE for engine oil and filter change frequencies. You should also change generator engine oil before placing the vehicle into storage.

Drain the oil while engine is still warm from running, which means warm up the engine, shut it down and drain immediately as follows (Figure 12):

1. Remove OIL DRAIN HOSE from its retaining clip.
2. Loosen and remove OIL DRAIN HOSE CAP. Drain oil completely into suitable container.
3. When all oil has drained, install and tighten OIL DRAIN HOSE CAP.
4. Turn OIL FILTER counterclockwise and remove. Dispose of old filter.
5. Apply a light coating of new engine oil to seal of new oil filter. Install FILTER and tighten by hand only. DO NOT OVERTIGHTEN.
6. Remove OIL FILLER CAP, add recommended oil (see SPECIFICATIONS). DO NOT OVERFILL ABOVE THE DIPSTICK "FULL" MARK. Crankcase oil capacity is 3.7 U.S. quarts (3.5 liters).



**CAUTION!** After refilling the crankcase with oil, always check oil level on dipstick. NEVER OPERATE ENGINE WITH OIL BELOW THE DIPSTICK "ADD" MARK.

7. Start engine and check for oil leaks.

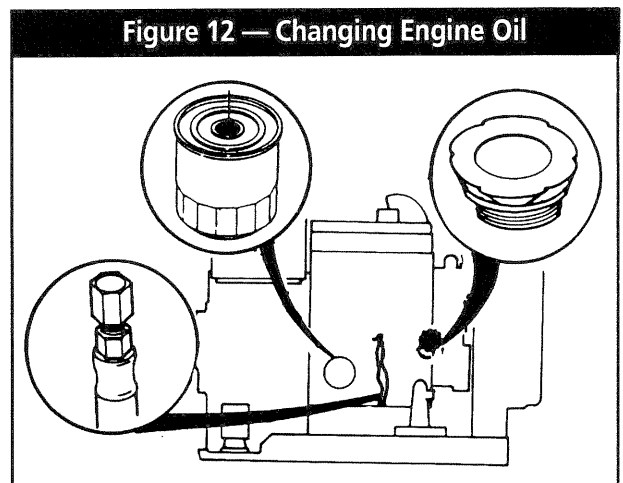

## COOLANT CHANGE

Every two years, the cooling system should be drained, flushed and refilled by an Authorized Service Facility. See SPECIFICATIONS for cooling system recommendations.

## MISCELLANEOUS MAINTENANCE

### ■ CLEANING THE GENERATOR

Keep your standby generator as clean and as dry as possible. Dirt and moisture that is allowed to accumulate on internal generator windings have an adverse effect on insulation resistance.

Periodically clean generator exterior surfaces. A soft brush may be used to loosen caked on dirt. You can use a vacuum system or dry, low pressure air to remove any accumulations of dirt. If the generator is housed inside an all-weather enclosure, clean the enclosure with a soft, damp cloth or sponge and water.

Once each year have the generator cleaned and inspected by an Authorized Service Facility. That facility will use dry, low pressure air to clean internal windings. Parts inside the control console should be cleaned and inspected date this time as well.

Finally, have the insulation resistance of stator and rotor windings checked. If insulation resistances are excessively low, the generator may require drying.

### ■ BATTERY

All lead-acid storage batteries discharge when not in use. Refer to specific instructions and warnings that accompany your battery. IF such information is not available, observe the following precautions when handling a battery:

- DO NOT use jumper cables and a booster battery to crank or start the generator engine.
- DO NOT recharge a weak battery while it is installed in the generator. Remove battery from generator and recharge in a well-ventilated area, away from fuel vapors, sparks, heat or flames.
- Battery electrolyte fluid is an extremely caustic sulfuric solution that can cause severe burns. DO NOT permit fluid to contact eyes, skin, clothing, painted surfaces, wiring insulation, etc. If you spill any battery fluid, flush the affected area with clear water immediately.
- Always wear safety glasses, rubber apron and gloves when handling a battery.
- Batteries give off explosive hydrogen gas while charging. The gas can form an explosive mixture around the battery for several hours after charging. Any spark, heat or flames can ignite the gas and cause an explosion which can shatter the battery, causing blindness or other serious injury.

## PERIODIC REPLACEMENT PARTS

Part Name	Generac Part No.
Oil Filter	127-70939
Radiator Cap	46627
Air Cleaner Element	70941
Fuel Filter	69858

# TROUBLESHOOTING

PROBLEM	POSSIBLE CAUSES	REMEDY
Engine won't crank	<ol style="list-style-type: none"> <li>1. 10 amp circuit breaker tripped.</li> <li>2. 14 amp fuse blown.</li> <li>3. Loose corroded or defective battery cables.</li> <li>4. Defective engine Start/Stop switch.</li> <li>5. Defective starter contactor.</li> <li>6. Defective starter motor.</li> <li>7. Low or discharged battery.</li> </ol>	<ol style="list-style-type: none"> <li>1. Reset circuit breaker.</li> <li>2. Replace fuse.</li> <li>3. Tighten clean or replace as necessary.</li> <li>4. Replace Start/Stop switch.</li> <li>5. Replace contactor.</li> <li>6. Replace starter motor.</li> <li>7. Charge or replace battery.</li> </ol>
Engine cranks but won't start.	<ol style="list-style-type: none"> <li>1. Vehicle fuel shutoff valve is closed.</li> <li>2. Out of fuel.</li> <li>3. Fuel solenoid (FS) is defective.</li> <li>4. Fuel pump (FP) is defective.</li> <li>5. Open Wire #14 from Engine Control C.B.</li> <li>6. Clogged fuel filter or fuel line.</li> <li>7. Engine mechanical parts failure.</li> </ol>	<ol style="list-style-type: none"> <li>1. Open valve.</li> <li>2. Replenish fuel tank.</li> <li>3. Replace solenoid.</li> <li>4. Repair or replace fuel pump.</li> <li>5. Reconnect wire.</li> <li>6. Replace if clogged.</li> <li>7. Repair or replace parts.</li> </ol>
Engine starts hard, runs rough.	<ol style="list-style-type: none"> <li>1. Flame arrestor (air cleaner) plugged or damaged.</li> <li>2. Defective fuel pump.</li> <li>3. Plugged fuel filter or fuel line.</li> <li>4. Water in fuel.</li> <li>5. Improper pre-heat.</li> </ol>	<ol style="list-style-type: none"> <li>1. Clean or replace as needed.</li> <li>2. Replace or repair fuel pump.</li> <li>3. Replace filter; unclog fuel line.</li> <li>4. Drain tank and refill.</li> <li>5. Pre-heat unit.</li> </ol>
Engine starts, shuts down when Start/Stop switch is released.	<ol style="list-style-type: none"> <li>1. Engine oil level is low.</li> <li>2. Engine is overheated.</li> <li>3. Defective low oil pressure switch.</li> <li>4. Defective coolant temperature switch.</li> <li>5. Defective engine controller circuit board.</li> <li>6. Low coolant level.</li> </ol>	<ol style="list-style-type: none"> <li>1. Check oil and add oil as needed.</li> <li>2. Check cooling system for leaks.</li> <li>3. Replace switch.</li> <li>4. Replace switch.</li> <li>5. Replace circuit board.</li> <li>6. Repair leak and add antifreeze mixture as needed.</li> </ol>
Start/Stop Switch at STOP, engine continues to run.	<ol style="list-style-type: none"> <li>1. Defective Start/Stop switch.</li> <li>2. Open/disconnected wire #18 between Start/Stop switch &amp; engine controller C.B.</li> <li>3. Open/disconnected wire #0 between Start/Stop switch &amp; engine controller C.B.</li> <li>4. Defective Engine Controller circuit board.</li> </ol>	<ol style="list-style-type: none"> <li>1. Replace switch.</li> <li>2. Reconnect/close wire.</li> <li>3. Reconnect/close wire.</li> <li>4. Replace board.</li> </ol>
No AC output from generator.	<ol style="list-style-type: none"> <li>1. Check main circuit breaker.</li> <li>2. Check vehicle circuit breaker &amp; fuses.</li> <li>3. Generator internal failure.</li> </ol>	<ol style="list-style-type: none"> <li>1. Reset to ON or CLOSED.</li> <li>2. Reset and replace, if necessary.</li> <li>4. Take generator to authorized Generac service facility.</li> </ol>

# WIRING DIAGRAM — NP-75D GENERATOR

Drawing No. 83623-A

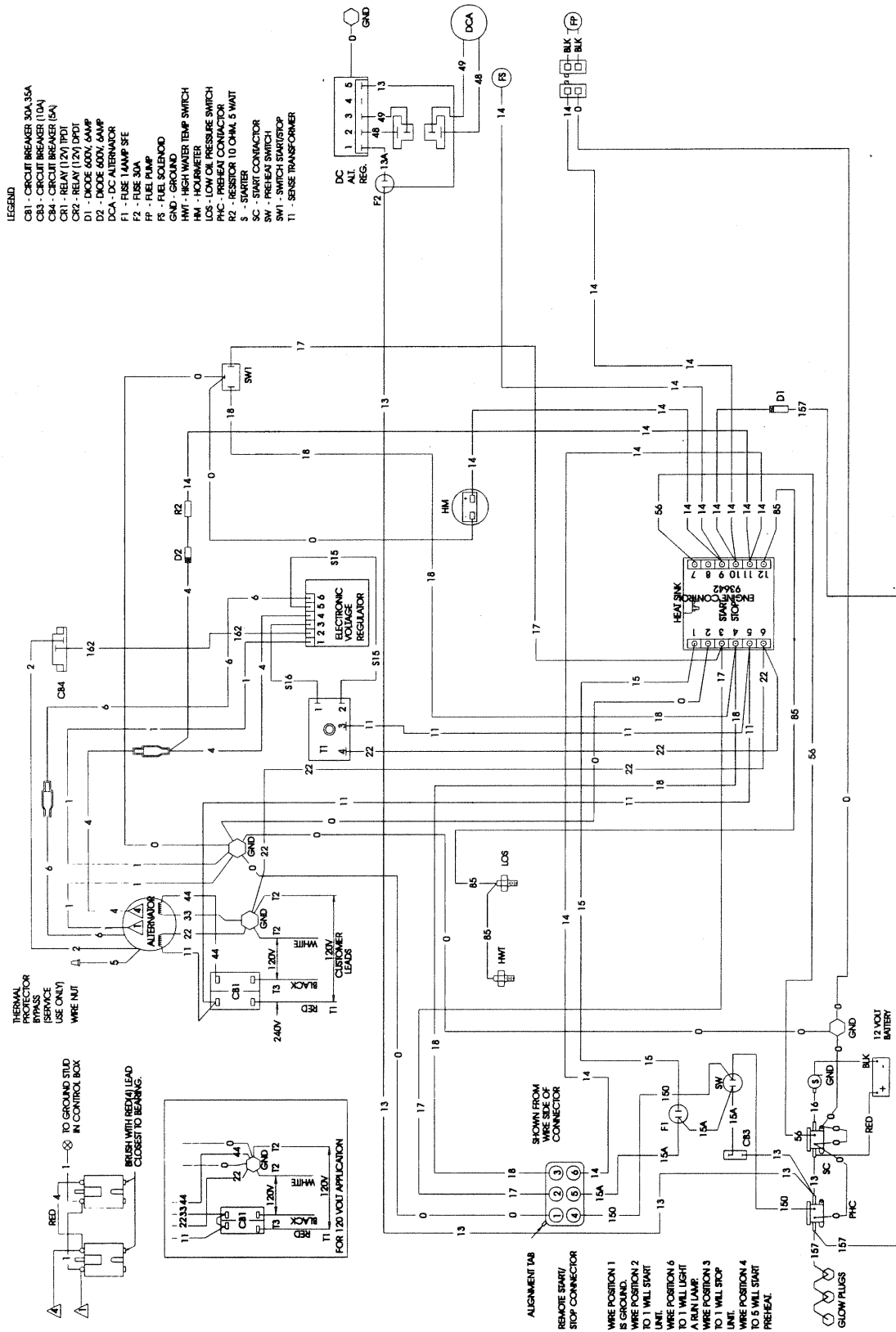



# ELECTRICAL SCHEMATIC — NP 75D GENERATOR

Drawing No. 83625-

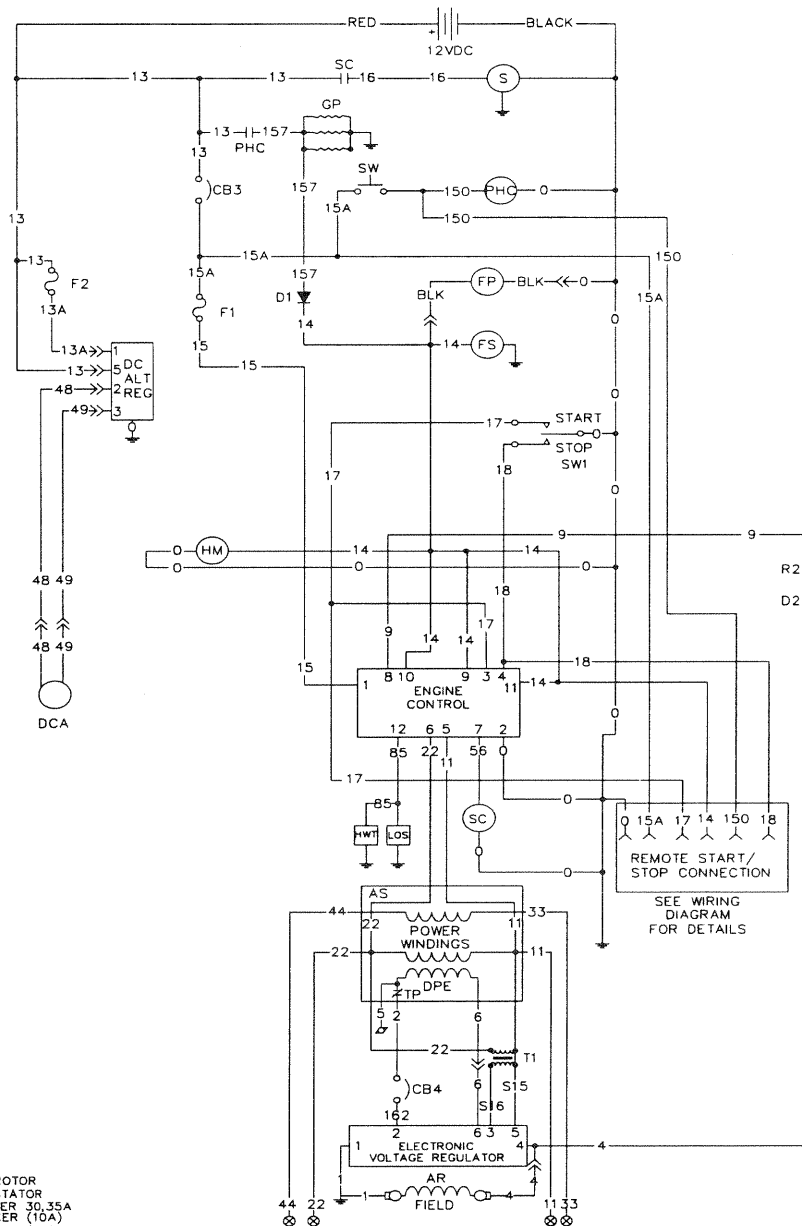

## LEGEND

- AR - ALTERNATOR ROTOR
- AS - ALTERNATOR STATOR
- CB1 - CIRCUIT BREAKER 30, 35A
- CB3 - CIRCUIT BREAKER (10A)
- CB4 - CIRCUIT BREAKER (5A)
- D1 - DIODE 600V, 6AMP
- D2 - DIODE 600V, 8AMP
- DCA - DC ALTERNATOR
- DPE - EXCITATION WINDING
- F1 - FUSE 14AMP SFE
- F2 - FUSE 30A
- FS - FUEL SOLENOID
- FP - FUEL PUMP
- HM - HOURMETER
- HWT - HIGH WATER TEMP SWITCH
- LOS - LOW OIL PRESSURE SWITCH
- PHC - PREHEAT CONTACTOR
- R2 - RESISTOR 10 OHM, 5W
- S - STARTER
- SC - START CONTACTOR
- SW - PREHEAT SWITCH
- SW1 - SWITCH, START/STOP
- T1 - SENSE TRANSFORMER
- TP - THERMAL PROTECTOR

## CONNECTION OPTIONS

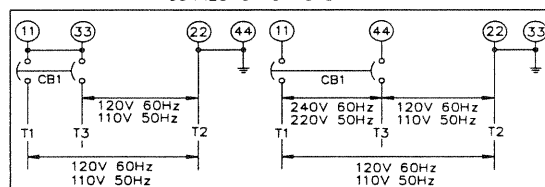

# EXPLODED VIEW — ENGINE COMMON PARTS

Drawing No. 81982-B

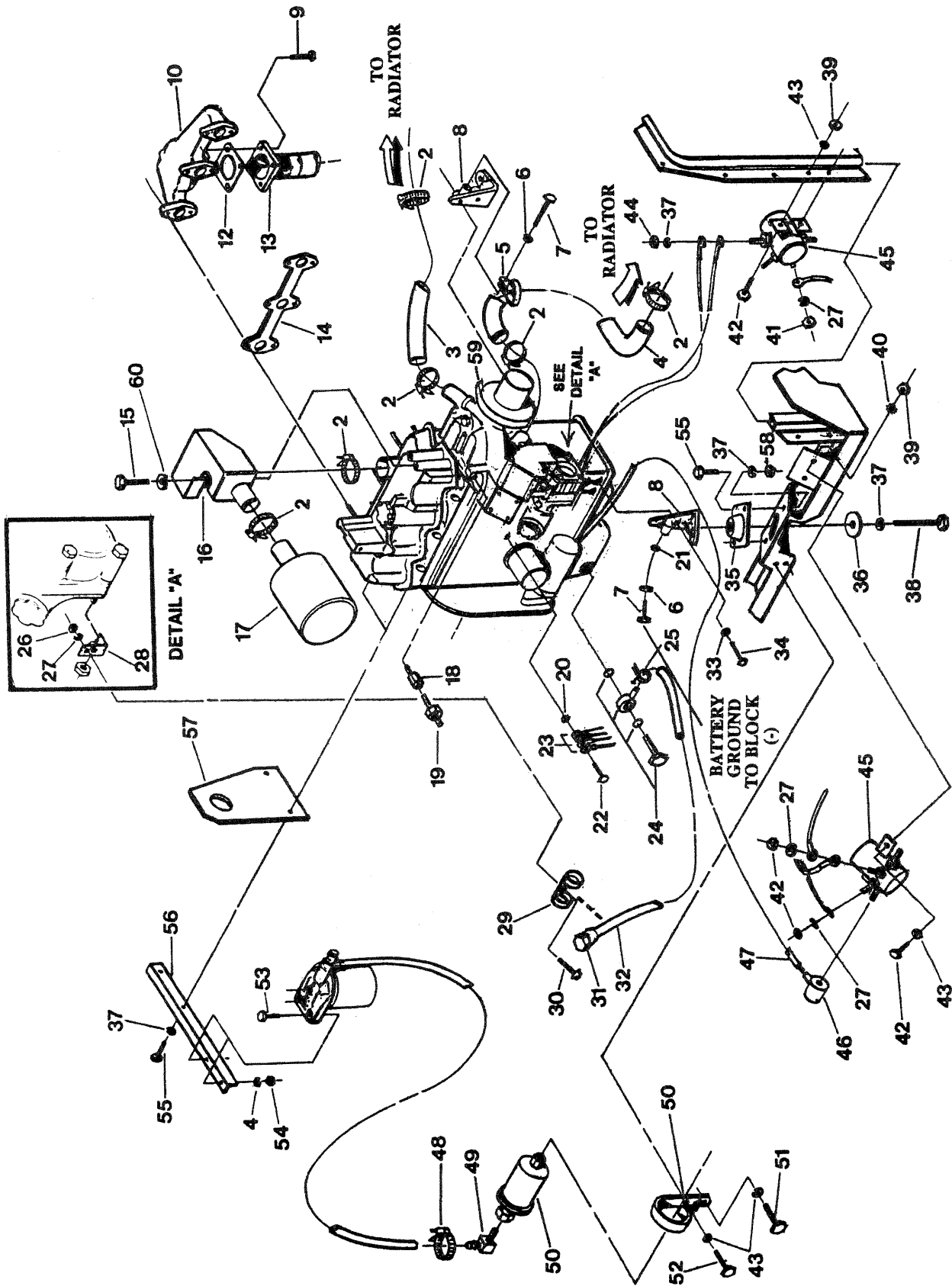

# REPAIR PARTS LIST — ENGINE COMMON PARTS

Drawing No. 81982-B

ITEM	PART NO.	QTY.	DESCRIPTION	ITEM	PART NO.	QTY.	DESCRIPTION
1	81932	1	ENGINE 1L DIESEL	31	69811	1	CAP HEX 1/4" BRASS
2	35586	6	CLAMP, HOSE #20	32	69860-B	1	HOSE-OIL DRAIN
3	81946	1	HOSE-RADIATOR, UPPER	33	74018	4	WASHER, LOCK-M12
4	81947	1	HOSE-RADIATOR, LOWER	34	74070	4	M12-1.25 x 40MM HHCS
5	55934	1	HOSE CLAMP	35	70936	2	MOUNT, VIBRATOR
6	22302	4	WASHER, LOCK	36	71956	2	WASHER, VIB. ISOLATION
7	51755	2	M10-1.5 x 16MM HHCS	37	22129	12	WASHER, LOCK 5/16"-M8
8	72501	2	SUPPORT, ENGINE	38	51730	2	M8-1.25 x 60MM CAPSCREW
9	43107	4	M8-1.25 x 25MM HHCS				
10	81942	1	MANIFOLD, EXHAUST	39	49813	4	NUT, HEX M6-1.0
11	49813	6	NUT, HEX M6-1.0	40	26850	2	SHAKEPROOF EXT 1/4"-M6
12	75674	1	GASKET, EXHAUST OUTLET	41	22158	4	NUT, HEX #10-32
13	81975	1	OUTLET, EXHAUST-FLEX	42	42568	4	M6-1.0 x 20MM HHCS
14	357-70939	1	GASKET, MANIFOLD	43	22097	6	WASHER, LOCK 1/4"-M6
15	42909	1	M8-1.25 x 30MM HHCS	44	24114	4	NUT, HEX 5/16"-24
16	81936	1	CHAMBER, AIR INTAKE	45	56739	2	SOLENOID, RELAY 12V.
17	70941	1	FILTER, AIR	46	75763	2	BOOT, RED VINYL
18	42574	1	ADAPTOR, 1/8" NPT-1/8"-28	47	77745	1	CABLE, STARTER
19	60108	1	SWITCH, OIL PRESSURE	48	40173	1	CLAMP, HOSE #5.5
20	26204	1	SHAKEPROOF WASHER M6	49	49340	1	BARB, 90 DEG. 3/8" x 1/4" NPT
21	25507	1	SHAKEPROOF EXT. 7/16"	50	74024	1	PUMP, FUEL ASSEMBLY
22	42568	1	M8-1.25 x 20MM HHCS	51	43146	1	M6-1.0 x 10MM HHCS
23	81951	1	HARNESS, ENGINE WIRE	52	45757	1	M10-1.0 x 25MM HHCS
24	72573	1	BANJO FITTING ASSY. M12	53	57642	2	M10 x 1.5 x 40MM HHCS
25	70928	1	CLAMP, HOSE	54	45772	2	NUT, HEX M10 x 1.5
26	51716	1	NUT, HEX-M5-0.8	55	39253	6	M8 x 1.25 x 20MM HHCS
27	22152	5	WASHER, LOCK #10	56	72564	1	BRACKET, FUEL FILTER
28	81939	1	BRACKET, OIL DRAIN	57	71910-A	1	LIFTING BRACKET
29	65852	1	CLIP, OIL DRAIN HOSE	58	45771	4	HEX NUT M8-1.25
30	71912	1	M5-0.8 x 8MM PPHMS	59	46233	1	V-BELT, 3/8"-30-1/8" LONG
				60	50190	1	WASHER, FLAT SPECIAL-M8

# EXPLODED VIEW — ENGINE BLOCK

Drawing No. 82961-

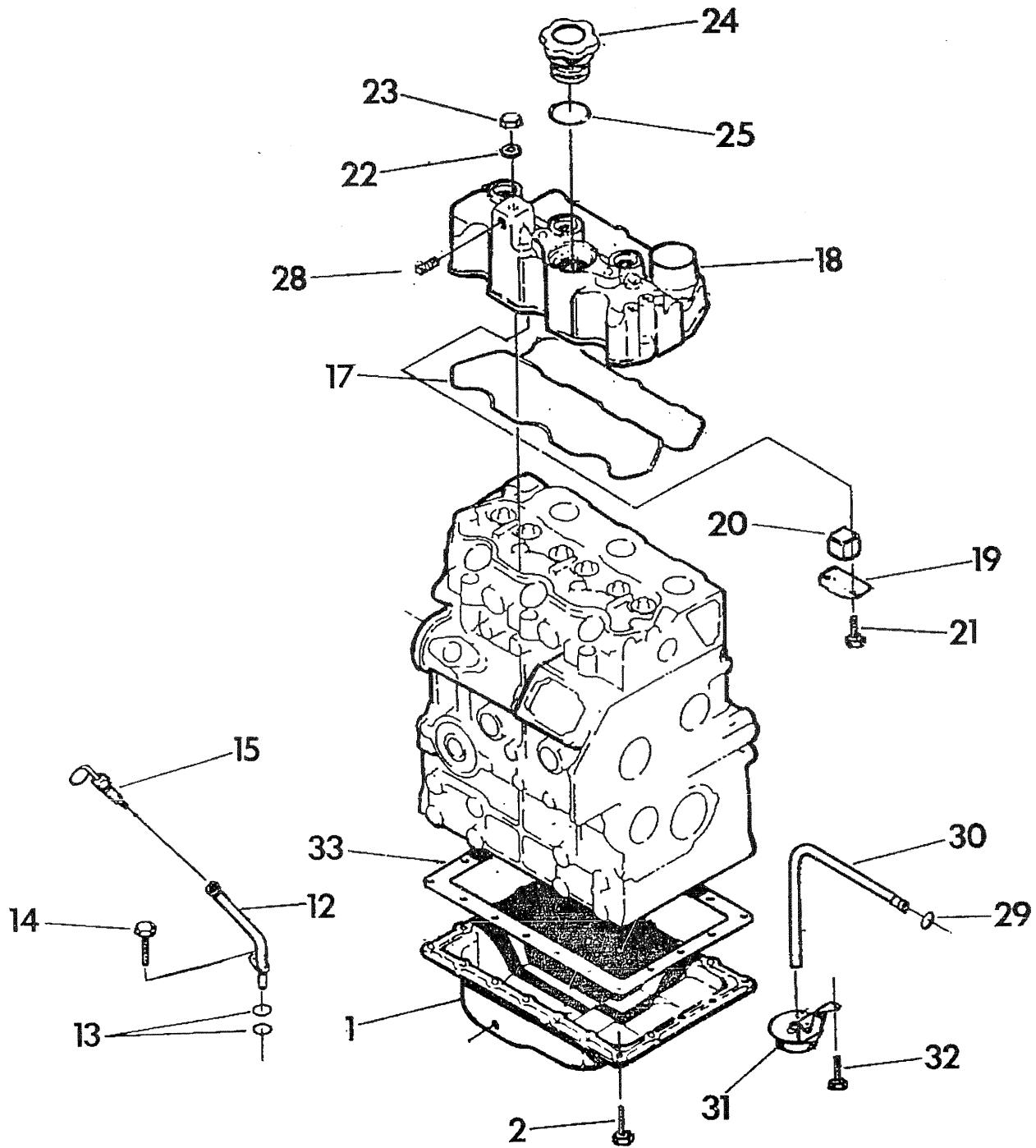

# EXPLODED VIEW — ENGINE BLOCK

Drawing No. 82961-

ITEM	PART NO.	QTY.	DESCRIPTION
1	139-70939	1	OIL PAN
2	140-70939	20	BOLT
12	143-70939	1	DIPSTICK TUBE
13	144-70939	2	O-RING
14	145-70939	1	BOLT
15	146-70939	1	DIPSTICK
16	182-70939	1	ROCKER COVER GASKET
17	183-70939	1	ROCKER COVER GASKET
18	184-70939	1	ROCKER COVER
19	185-70939	1	OIL STOPPER
20	186-70939	1	SCREEN
21	145-70939	2	BOLT
22	168-70939	1	GASKET
23	187-70939	3	NUT
24	188-70939	1	CAP
25	189-70939	1	O-RING
28	26073-A	1	1/4" PIPE PLUG SQ.HD
29	244-70939	1	O-RING
30	245-70939	1	TUBING
31	246-70939	1	SUCTION FILTER
32	145-70939	2	BOLT
33	122-70939	1	GASKET

# EXPLODED VIEW — CRANKSHAFT, PISTON & FLYWHEEL

Drawing No. 75679-

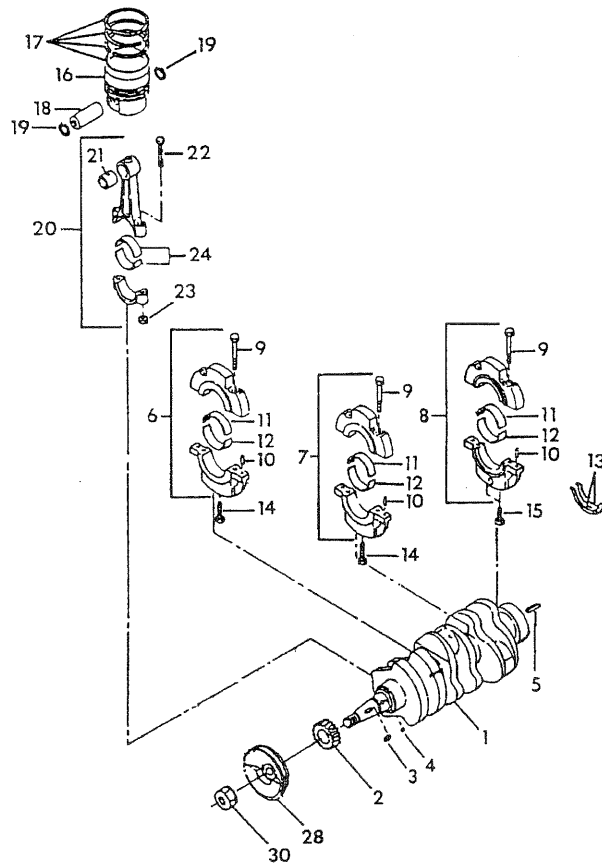

ITEM	PART NO.	QTY.	DESCRIPTION	ITEM	PART NO.	QTY.	DESCRIPTION
1	143-70939	1	CRANKSHAFT ASSEMBLY	17	211-70939	3	STANDARD PISTON RING SET
2	194-70939	1	CRANKSHAFT GEAR		212-70939	AR	PISTON RING SET-0.5MM O.S.
3	195-70939	1	KEY		213-70939	AR	PISTON RING SET-1.0MM O.S.
4	196-70939	1	DOWEL PIN	18	217-70939	3	PISTON PIN
5	226-70939	1	SPRING PIN	19	218-70939	6	SNAP RING
6	197-70939	1	BEARING HOLDER	20	219-70939	3	CONNECTION ROD ASSEMBLY
7	200-70939	1	BEARING HOLDER	21	220-70939	3	BUSHING
8	201-70939	1	BEARING HOLDER	22	221-70939	6	CONNECTING ROD BOLT
9	198-70939	6	BOLT	23	222-70939	6	NUT, CONNECTING ROD BOLT
10	199-70939	6	DOWEL PIN	24	223-70939	6	STANDARD BEARING
11	202-70939	3	STANDARD BEARING		224-70939	AR	BEARING — 0.25MM U.S.
	203-70939	AR	0.25MM U.S. BEARING		225-70939	AR	BEARING — 0.50MM U.S.
	204-70939	AR	0.50MM U.S. BEARING	28	230-70939	1	PULLEY
12	205-70939	3	STANDARD BEARING	30	231-70939	1	NUT
	206-70939	AR	0.25MM U.S. BEARING				
	207-70939	AR	0.50MM U.S. BEARING				
13	208-70939	2	THRUST WASHER				
14	204-70939	2	BOLT				
15	210-70939	1	BOLT				
16	214-70939	3	STANDARD PISTON ASSEMBLY				
	215-70939	AR	PISTON ASSEMBLY-0.5MM O.S.				
	216-70939	AR	PISTON ASSEMBLY-1.0MM O.S.				

U.S. — UNDERSIZE  
O.S. — OVERSIZE  
AR — AS REQUIRED

# EXPLODED VIEW — CYLINDER HEAD

Drawing No. 75678-

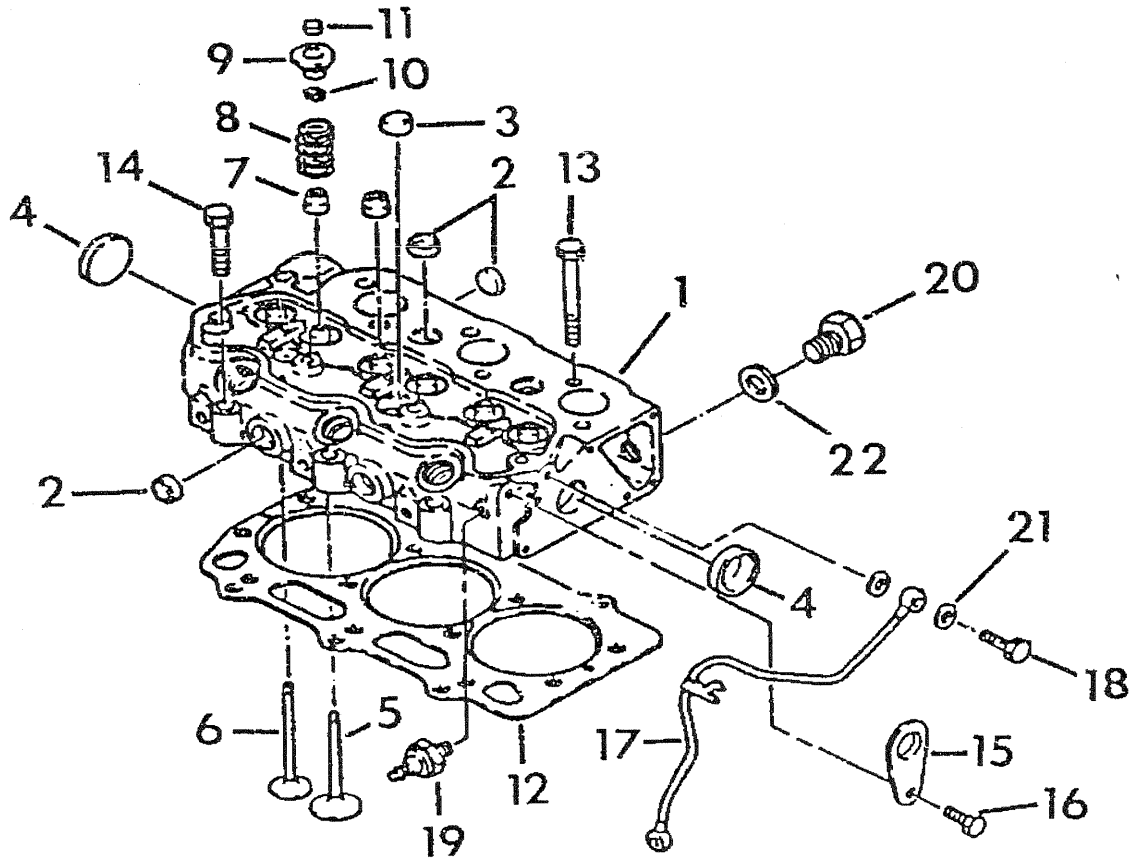

ITEM	PART NO.	QTY.	DESCRIPTION
1	147-70939	1	CYLINDER HEAD ASSEMBLY
2	148-70939	6	EXPANSION PLUG
3	447-70939	3	EXPANSION PLUG
4	149-70939	2	EXPANSION PLUG
5	150-70939	3	INTAKE VALVE
6	151-70939	3	EXHAUST VALVE
7	152-70939	3	VALVE GUIDE SEAL (EXHAUST)
	153-70939	3	VALVE GUIDE SEAL (INTAKE)
8	154-70939	6	SPRING
9	155-70939	6	RETAINER
10	156-70939	12	KEY
11	157-70939	6	CAP
12	158-70939	1	CYLINDER HEAD GASKET, 1.2MM THICK
	159-70939	1	CYLINDER HEAD GASKET, 1.3MM THICK
13	160-70939	11	BOLT
14	161-70939	3	BOLT
15	162-70939	2	LIFTING EYE
16	163-70939	2	BOLT
17	164-70939	1	TUBING
18	165-70939	2	BOLT
19	60108	1	OIL SWITCH
20	167-70939	1	THERMO-SWITCH
21	168-70939	4	GASKET
22	169-70939	1	WASHER

# EXPLODED VIEW — CAM SHAFT

Drawing No. 75677-

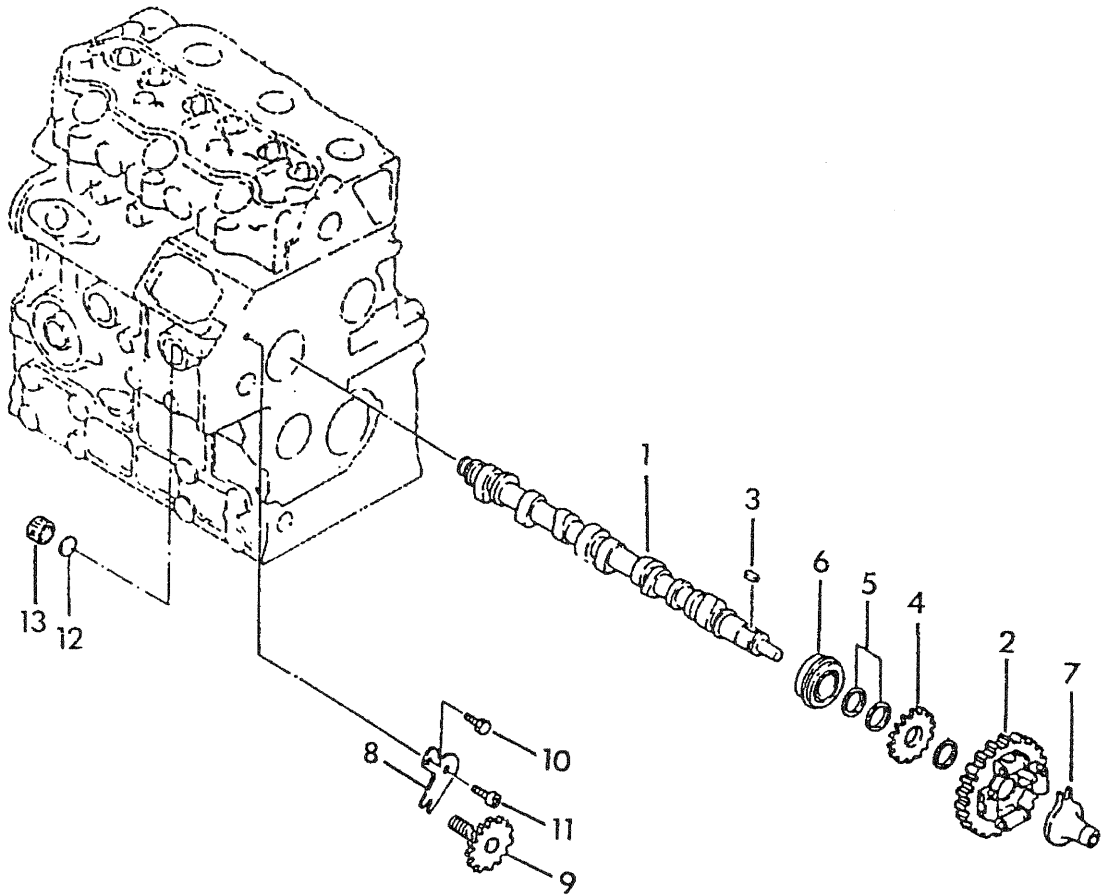

ITEM	PART NO.	QTY.	DESCRIPTION
1	232-70939	1	CAMSHAFT ASSEMBLY
2	233-70939	1	CAMSHAFT GEAR
3	195-70939	1	KEY
4	234-70939	1	GEAR
5	235-70939	3	SPACER
6	236-70939	1	BALL BEARING
7	237-70939	1	SLIDER
8	238-70939	1	PLATE
9	239-70939	1	TACHOMETER SHAFT
10	240-70939	1	BOLT
11	241-70939	1	BOLT
12	242-70939	1	GASKET
13	243-70939	1	NUT



# EXPLODED VIEW — CYLINDER BLOCK

Drawing No. 75676-

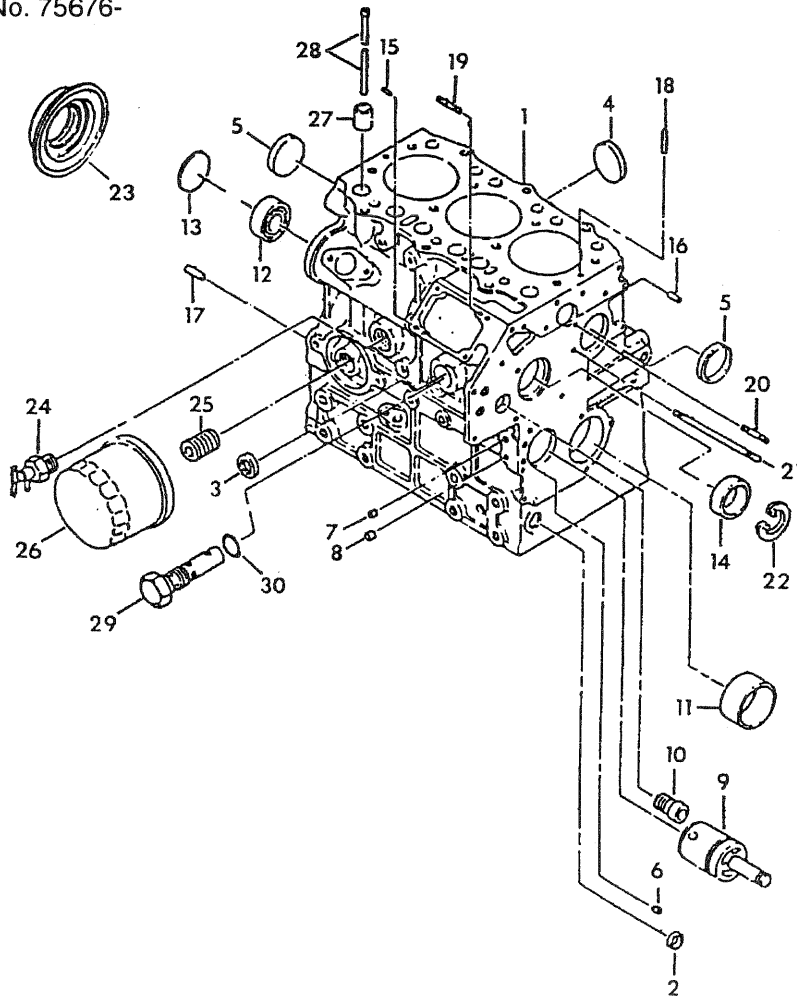

ITEM	PART NO.	QTY.	DESCRIPTION	ITEM	PART NO.	QTY.	DESCRIPTION
1	100-70939	1	COMPLETE CYLINDER BLOCK	17	117-70939	2	DOWEL PIN
2	447-70939	1	EXPANSION PLUG	18	118-70939	2	SPRING PIN
3	101-70939	1	EXPANSION PLUG	19	119-70939	2	STUD
4	102-70939	2	EXPANSION PLUG	20	120-70939	1	PUSH ROD
5	103-70939	2	EXPANSION PLUG	21	121-70939	1	STUD
6	104-70939	1	EXPANSION PLUG	22	131-70939	1	SNAP RING
7	105-70939	4	PLUG	23	123-70939	1	OIL SEAL
8	106-70939	4	PLUG	24	124-70939	1	DRAIN COCK
9	107-70939	1	IDLE GEAR SHAFT	25	125-70939	1	CONNECTOR
10	108-70939	1	BUSHING	26	126-70939	1	OIL FILTER
11	108-70939	1	BUSHING — STANDARD	27	127-70939	6	TAPPET
	110-70939	1	0.25MM U.S. BUSHING	28	128-70939	6	PUSH ROD
	111-70939	1	0.50MM U.S. BUSHING	29	129-70939	1	RELIEF VALVE
12	112-70939	1	BALL BEARING	30	130-70939	1	O-RING
13	113-70939	1	EXPANSION PLUG				
14	114-70939	1	BALL BEARING				
15	115-70939	1	DOWEL PIN				
16	116-70939	1	DOWEL PIN				

MM = MILLIMETER  
U.S. = UNDERSIZE

# EXPLODED VIEW — OIL PUMP COMPONENTS

Drawing No. 75682-

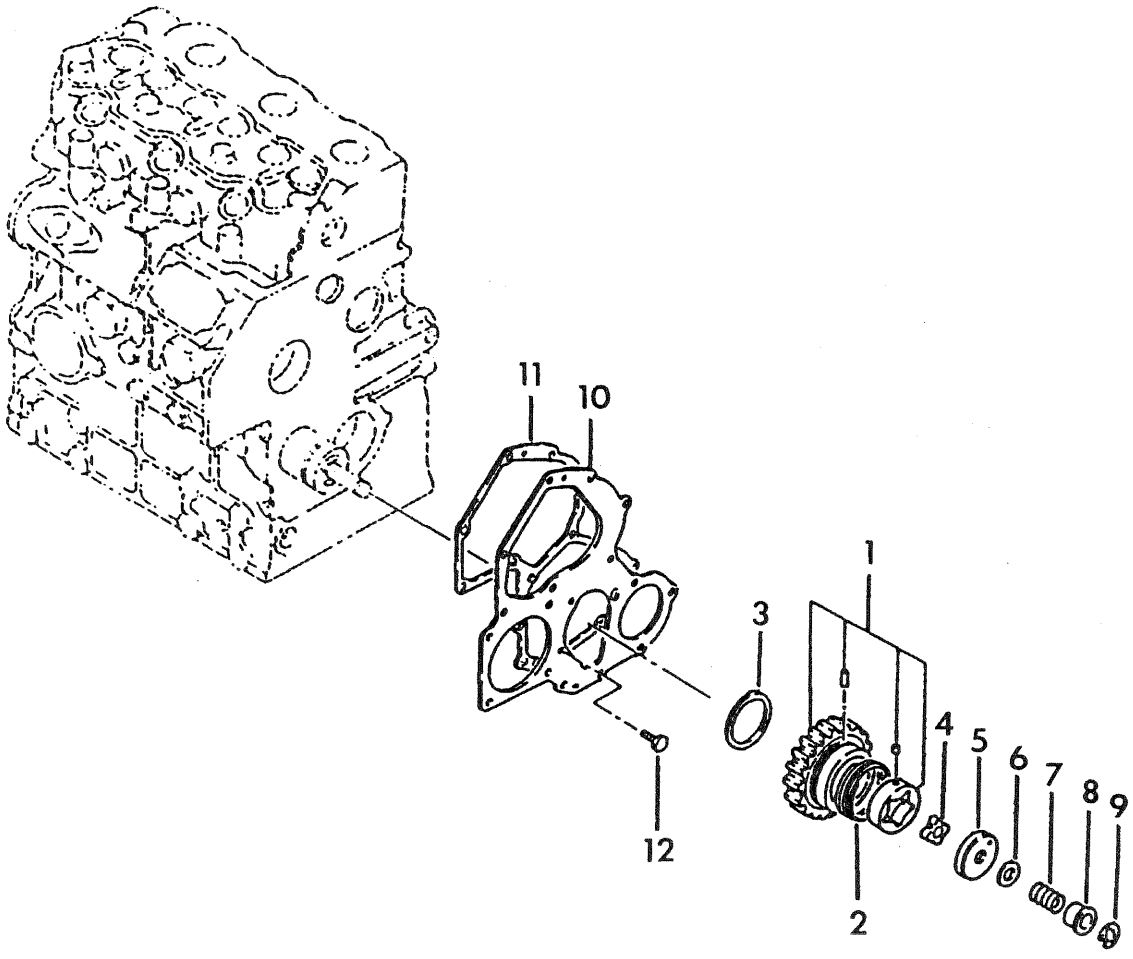

ITEM	PART NO.	QTY.	DESCRIPTION
1	250-70939	1	IDLER GEAR ASSEMBLY
2	252-70939	1	SPRING
3	251-70939	1	THRUST WASHER
4	253-70939	1	ROTOR
5	254-70939	1	OIL PUMP COVER
6	255-70939	AR	0.10MM SHIM
	532-70939	AR	0.15MM SHIM
	533-70939	AR	0.20MM SHIM
	258-70939	AR	0.50MM SHIM
7	259-70939	1	SPRING
8	260-70939	1	COLLAR
9	261-70939	1	SNAP RING
10	262-70939	1	FRONT PLATE
11	263-70939	1	GASKET
12	264-70939	3	BOLT

AR — AS REQUIRED

# EXPLODED VIEW — ROCKER ARM ASSEMBLY

Drawing No. 75683-

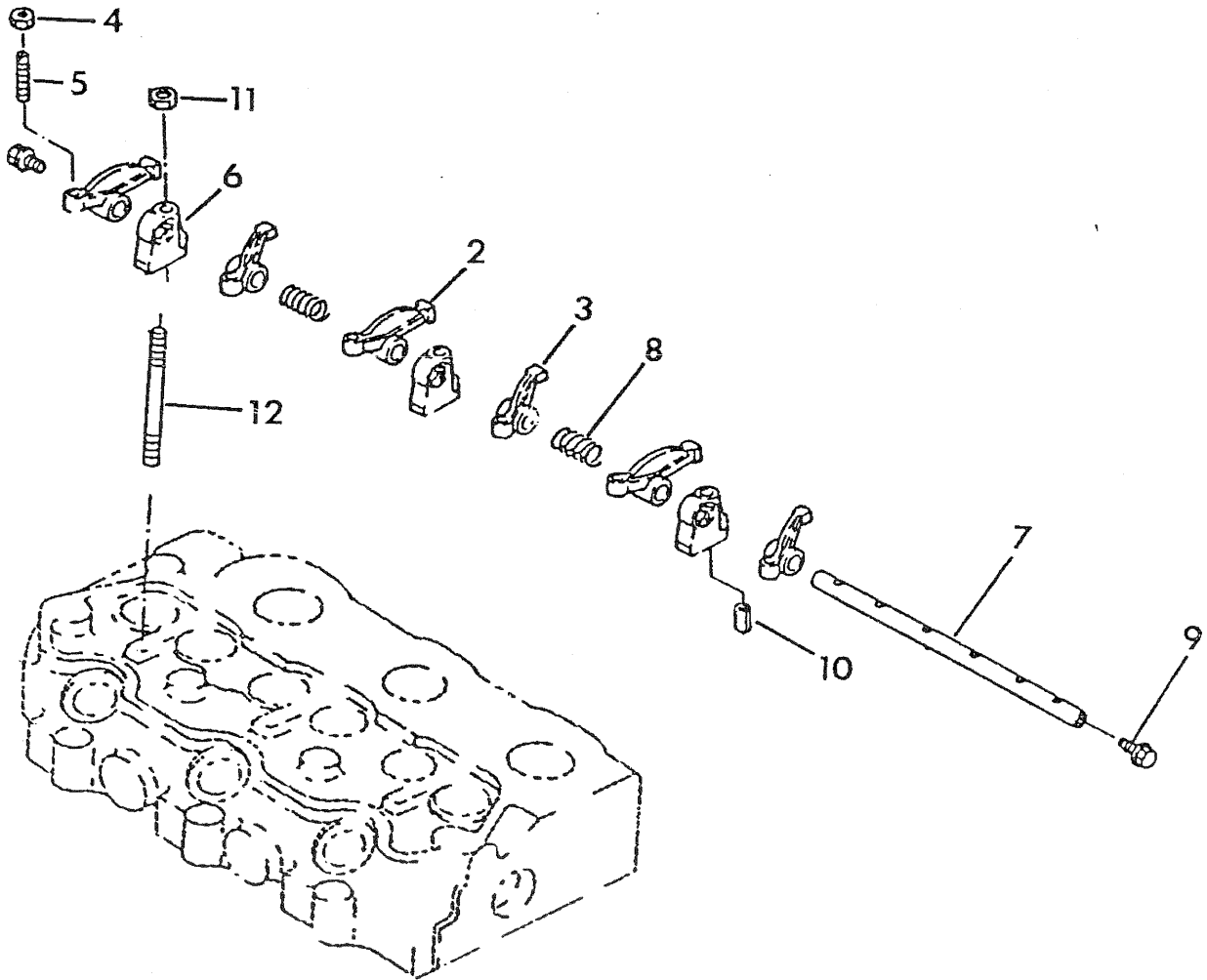

ITEM	PART NO.	QTY.	DESCRIPTION
1	170-70939	1	ROCKER ARM ASSEMBLY
2	171-70939	3	INTAKE ROCKER ARM
3	172-70939	3	EXHAUST ROCKER ARM
4	174-70939	6	NUT
5	173-70939	6	STUD
6	175-70939	3	ROCKER ARM BRACKET
7	176-70939	1	ROCKER ARM SHAFT
8	177-70939	2	SPRING
9	178-70939	2	SCREW
10	179-70939	1	SPRING PIN
11	180-70939	3	NUT
12	181-70939	3	STUD



# EXPLODED VIEW — WATER PUMP

Drawing No. 82962-

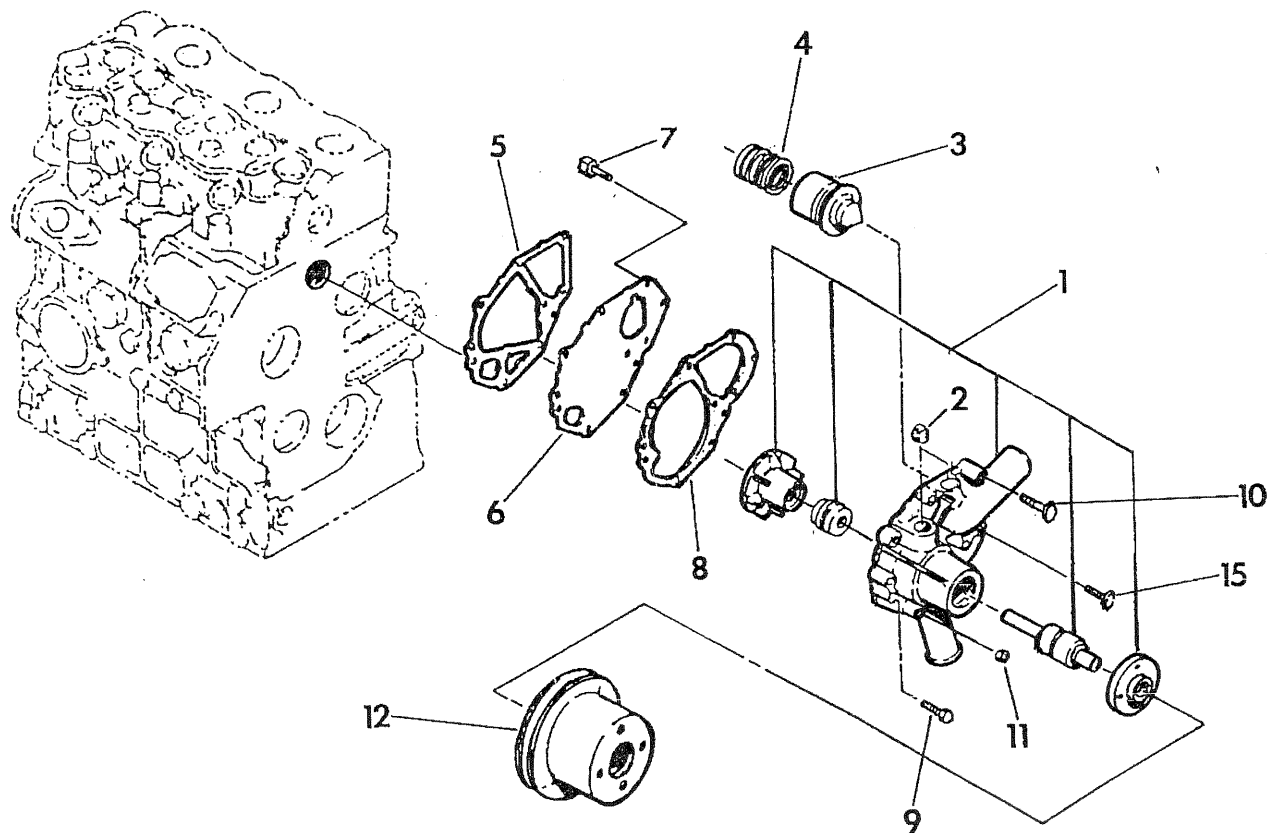

ITEM	PART NO.	QTY.	DESCRIPTION
1	265-70939	1	WATER PUMP ASSEMBLY
2	266-70939	1	PLUG
3	267-70939	1	THERMOSTAT
4	268-70939	1	SPRING
5	269-70939	3	GASKET
6	270-70939	1	SET PLATE
7	271-70939	1	BOLT
8	272-70939	1	GASKET
9	273-70939	1	BOLT
10	274-70939	1	BOLT
11	275-70939	1	NUT
12	247-70939	1	PULLEY
15	284-70939	1	BOLT

# EXPLODED VIEW — INJECTOR PUMP

Drawing No. 75686-A

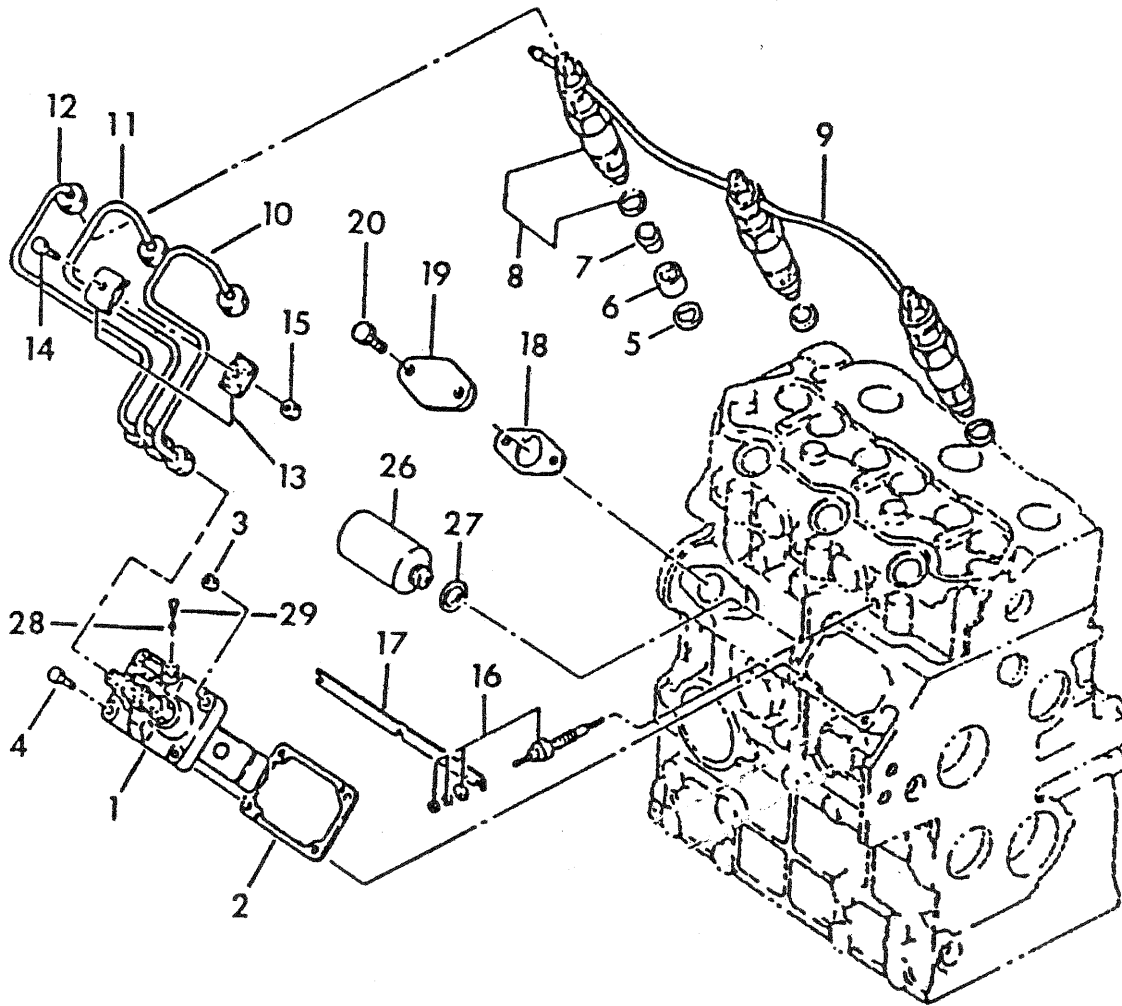

ITEM	PART NO.	QTY.	DESCRIPTION	ITEM	PART NO.	QTY.	DESCRIPTION
1	316-70939	1	INJECTOR PUMP ASSEMBLY	11	328-70939	1	TUBING
2	317-70939	AR	SHIM-0.2MM	12	329-70939	1	TUBING
	318-70939	AR	SHIM-0.3MM	13	330-70939	1	CLAMP
	319-70939	AR	SHIM-0.5MM	14	331-70939	1	BOLT
	320-70939	AR	SHIM-1.0MM	15	298-70939	1	NUT
3	298-70939	2	NUT	16	332-70939	3	GLOW PLUG
4	321-70939	2	BOLT	17	333-70939	1	CONNECTOR
5	322-70939	3	GASKET	18	334-70939	1	GASKET
6	323-70939	3	INSERT	19	335-70939	1	COVER
7	324-70939	3	CAP	20	264-70939	2	BOLT
8	325-70939	3	INJECTOR	26	341-90939	1	SOLENOID
9	326-70939	1	TUBING	27	342-70939	1	WASHER
10	327-70939	1	TUBING	28	343-70939	1	WASHER
				29	344-70939	1	SCREW

AR — AS REQUIRED

# EXPLODED VIEW — TIMING GEAR HOUSING AND GOVERNOR

Drawing No. 82067-

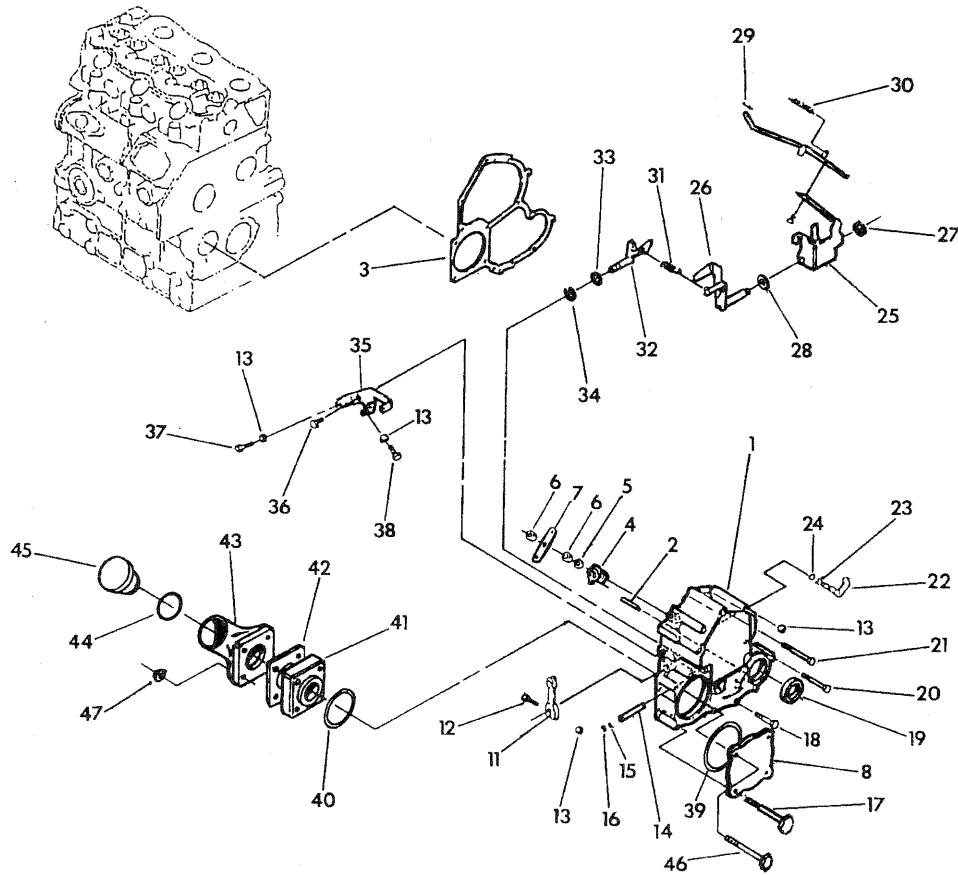

ITEM	PART NO.	QTY.	DESCRIPTION	ITEM	PART NO.	QTY.	DESCRIPTION
1	285-70939	1	TIMING GEAR HOUSING	26	290-70939	1	TENSION LEVEL
2	28670939	1	SPRING PIN	27	291-70939	1	SNAP RING
3	287-70939	1	GASKET	28	136-70939	1	WASHER
4	307-70939	1	SPRING	29	292-70939	1	COTTER PIN
5	308-70939	1	WASHER	30	313-70939	1	SPRING
6	309-70939	2	NUT	31	293-70939	1	SPRING
7	310-70939	1	STOP LEVER	32	294-70939	1	ARM
8	314-70939	2	COVER	33	295-70939	1	O-RING
11	296-70939	1	GOVERNOR LEVEL	34	291-70939	1	SNAP RING
12	297-70939	1	BOLT	35	302-70939	1	BRACKET
13	298-70939	4	NUT	36	271-70939	3	BOLT
14	299-70939	1	SHAFT	37	303-70939	2	BOLT
15	300-70939	1	O-RING	38	71944	1	HHCS M6-1.0 X 25 MM
16	301-70939	1	SNAP RING	39	660-70939	1	O-RING
17	540-70939	3	BOLT	40	534-70939	1	O-RING
18	282-70939	5	BOLT	41	535-70939	1	SPACER
19	288-70939	1	OIL SEAL	42	536-70939	1	GASKET
20	274-70939	4	BOLT	43	537-70939	1	HOLDER (OIL FILL)
21	311-70939	5	BOLT	44	539-70939	1	O-RING
22	304-70939	1	ARM	45	188-70939	1	CAP
23	305-70939	1	SNAP RING	46	541-70939	1	BOLT
24	306-70939	1	O-RING	47	538-70939	3	NUT
25	289-70939	1	GOVERNOR LEVEL ASSEMBLY				

# EXPLODED VIEW — RADIATOR

Drawing No. 83294-B

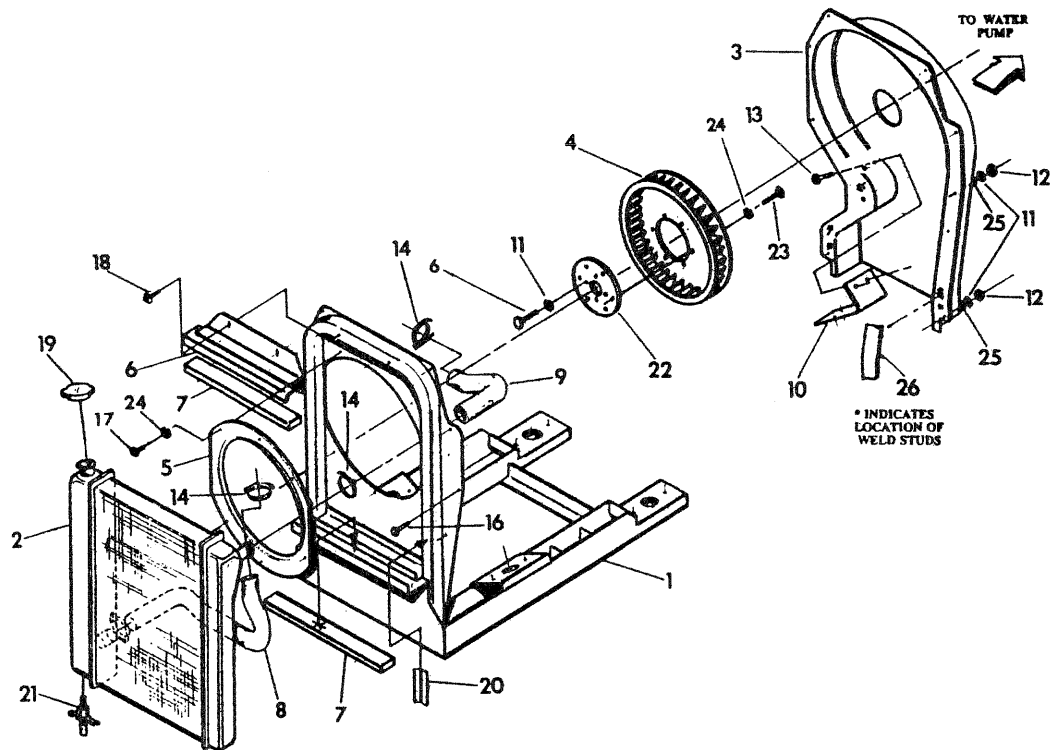

ITEM	PART NO.	QTY.	DESCRIPTION
1	83098	1	ASSEMBLY, BASE
2	83057	1	RADIATOR, CROSS FLOW
3	80245	1	BLOWER HOUSING
4	81905	1	FAN, ENGINE
5	82603	1	RING, FAN INLET
6	83058	1	BRACKET, RADIATOR MOUNTING
7	81977-A	2	FOAM PAD
8	81947	1	HOSE, LOWER RADIATOR
9	81946	1	HOSE, UPPER RADIATOR
10	82605	1	PLATE, BLOWER HOUSING
11	22097	7	LOCK WASHER-1/4"-M6
12	49813	11	NUT, HEX-M6-1.0
13	66831	2	RIVET-POP
14	35586	4	HOSE CLAMP #20
16	42568	11	CAPSCREW, HEX HEAD-M6-1.0 X 20 LONG
17	56892	6	CRIMPTITE, 10-24X 3/8" LONG
18	58442	2	CRIMPTITE, 1/4"-20 X 1/2" LONG
19	46627	1	CAP, RADIATOR
20	52250	5 FT.	FOAM PAD-3/4" X 1" WIDE
21	50832	1	DRAIN COCK-1/8" NPT
22	81976	1	HUB, FAN
23	51787	6	CAPSCR., HEX HD.-M4-0.7 X 16 LONG
24	22152	12	LOCK WASHER-#10
25	22473	11	FLAT WASHER-1/4"-M6
26	29451	5'	FOAM TAPE-1/8" X 1/2"



# EXPLODED VIEW — DC ALTERNATOR

Drawing No. 75685-A

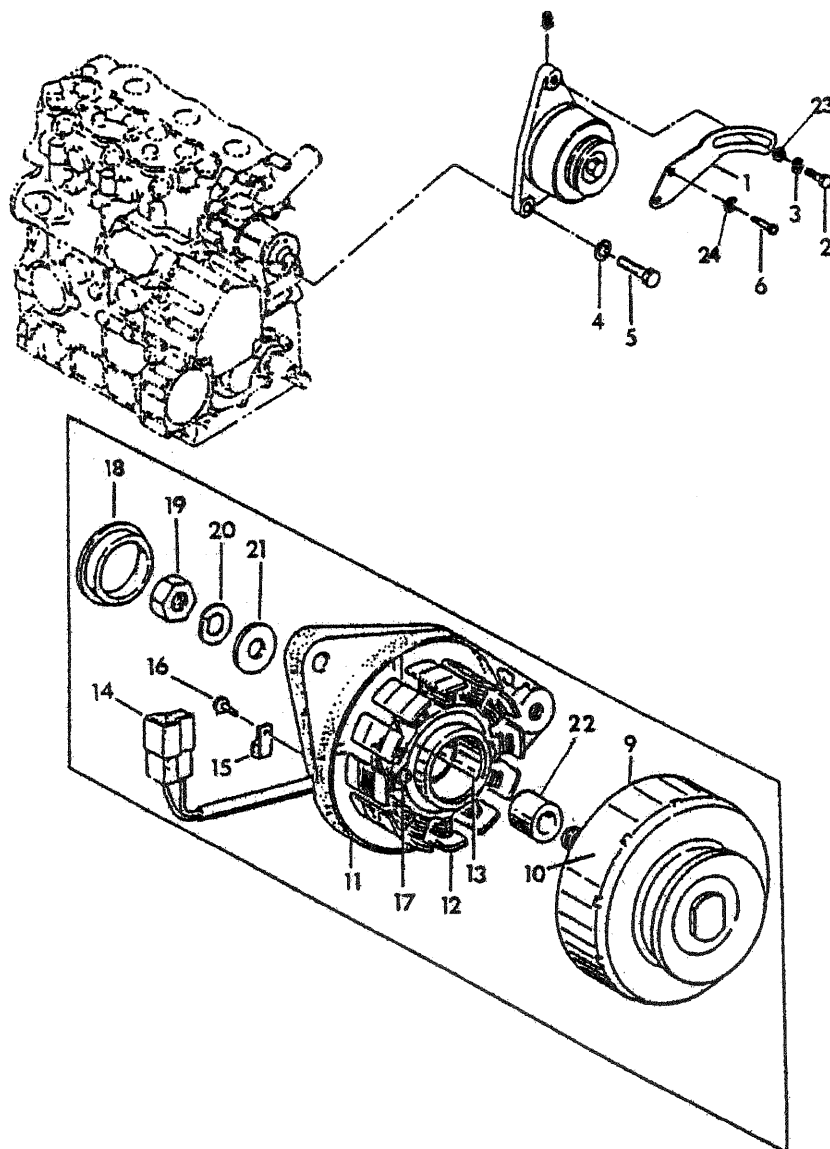

ITEM	PART NO.	QTY.	DESCRIPTION	ITEM	PART NO.	QTY.	DESCRIPTION
1	77909	1	ADJUSTING PLATE	14	352-70939	1	COUPLER
2	74829	1	HHCS M8-1.25 X 30MM	15	353-70939	1	CLAMP
3	72545	1	LOCK WASHER M8	16	354-70939	1	SCREW
4	74007	1	FLAT WASHER M10	17	355-70939	2	SCREW
5	74069	1	HHCS M10-1.5 x 40MM	18	350-70939	1	CAP
6	51753	2	HHCS M6-1.0 X 40MM	19	351-70939	1	NUT
8	277-70939	1	ALTERNATOR ASSEMBLY	20	137-70939	1	LOCK WASHER
9	345-70939	1	FLYWHEEL	21	280-70939	1	WASHER
10	349-70939	1	BEARING	22	356-70939	1	COLLAR
11	346-70939	1	PLATE ASSEMBLY	23	74827	1	FLAT WASHER M8
12	348-70939	1	STATOR	24	70005	2	LOCK WASHER M6-SS
13	349-70939	1	BEARING				

# EXPLODED VIEW — CONTROL BOX

Drawing No. 83699-B

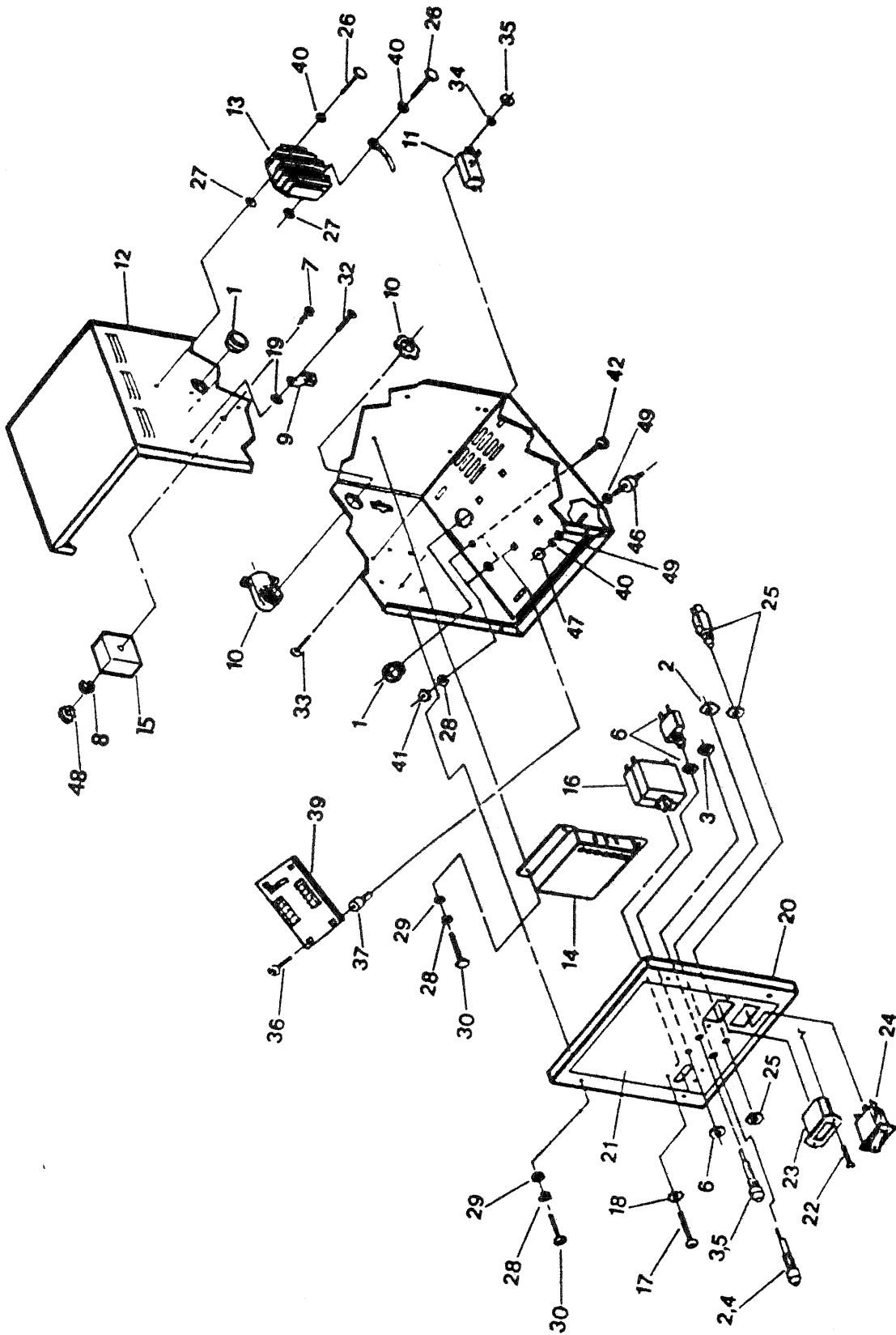

# REPAIR PARTS LIST — CONTROL BOX

Drawing No. 83699-B

ITEM	PART NO.	QTY.	DESCRIPTION	ITEM	PART NO.	QTY.	DESCRIPTION
1	23484-F	2	SNAP-BUSHING SB-1000-12	26	42568	2	CAPSCREW, HEX HEAD-M6-1.0 X 20MM
2	32300	1	FUSE HOLDER, 30 AMP AGC	27	26850	2	M6 EXTERNAL LOCK WASHER
3	81904	1	FUSE HOLDER, 14 AMP SFE	28	22152	10	LOCK WASHER-#10-M5
4	22668	1	AGC 30 AMP FUSE	29	23897	8	FLAT WASHER-#10-M5
5	55927	1	SFE 14 AMP FUSE	30	45770	8	CAPSCREW, HEX HEAD-M5-0.8 X 10MM LONG
6	75207-B	1	CIRCUIT BREAKER 10 AMP DC	31*	77744	1	CUSTOMER LEADS
7	22220	1	SCREW, ROUND HD. MACH.-#6 X 7/8" LONG	32	74041	1	M5-0.8 X 20MM LONG PHILLIPS PAN HEAD MACH. SCREW
8	22155	1	LOCK WASHER-#6	33	51718	2	M4-0.7 X 10MM LONG HHCS
9	25433	1	GROUND LUG	34	43184	2	LOCK WASHER-M4
10	39271	1	90 DEGREE CONDUIT CLAMP, 3/4" GREENLEE	35	51715	2	NUT, M4-0.7 HEX
11	48512	1	CIRCUIT BREAKER, 5AMP	36	80882	4	#6 X 5/8" SELF TAPPING SCREW
12	81903	1	CONTROL BOX	37	72566	4	SPACER NUT
13	71938-A	1	DC REGULATOR	39	70325	1	ENGINE CONTROLLER ASSEMBLY
14	67680	1	AC REGULATOR ASSEMBLY	40	22097	6	LOCK WASHER-1/4"-M6
15	83635	1	AC TRANSFORMER	41	51716	2	HEX NUT-M5
16	74969	1	CIRCUIT BREAKER, 35AMP	42	55440	2	CAPSCREW, HEX HEAD-M5-0.8 X 25MM
17	36900	4	PHILLIPS PAN HEAD MACH. SCREW-#6-32 X 1/4" LONG	44*	82617	1	PANEL WIRE HARNESS
18	22155	4	LOCK WASHER-#6	45*	81951	1	ENGINE WIRE HARNESS
19	23762	1	#10 EXTERNAL LOCK WASHER	46	82737	4	VIBRATION DAMPENER
20	81902	1	PANEL, CONTROL	47	49813	4	NUT-M6-1.0
21	81884-B	1	DECAL, CONTROL PANEL	48	22188	1	HEX NUT-#6-32
22	74076	2	PHM SCREW-M3-0.5 X 10MM LONG	49	22473	8	FLAT WASHER-1/4"-M6
23	77604	1	HOUR METER				
24	80825	1	START/STOP SWITCH				
25	55920	1	PRE-HEAT SWITCH				

\*NOT SHOWN ON DRAWING

# EXPLODED VIEW — GENERATOR

Drawing No. C1273-

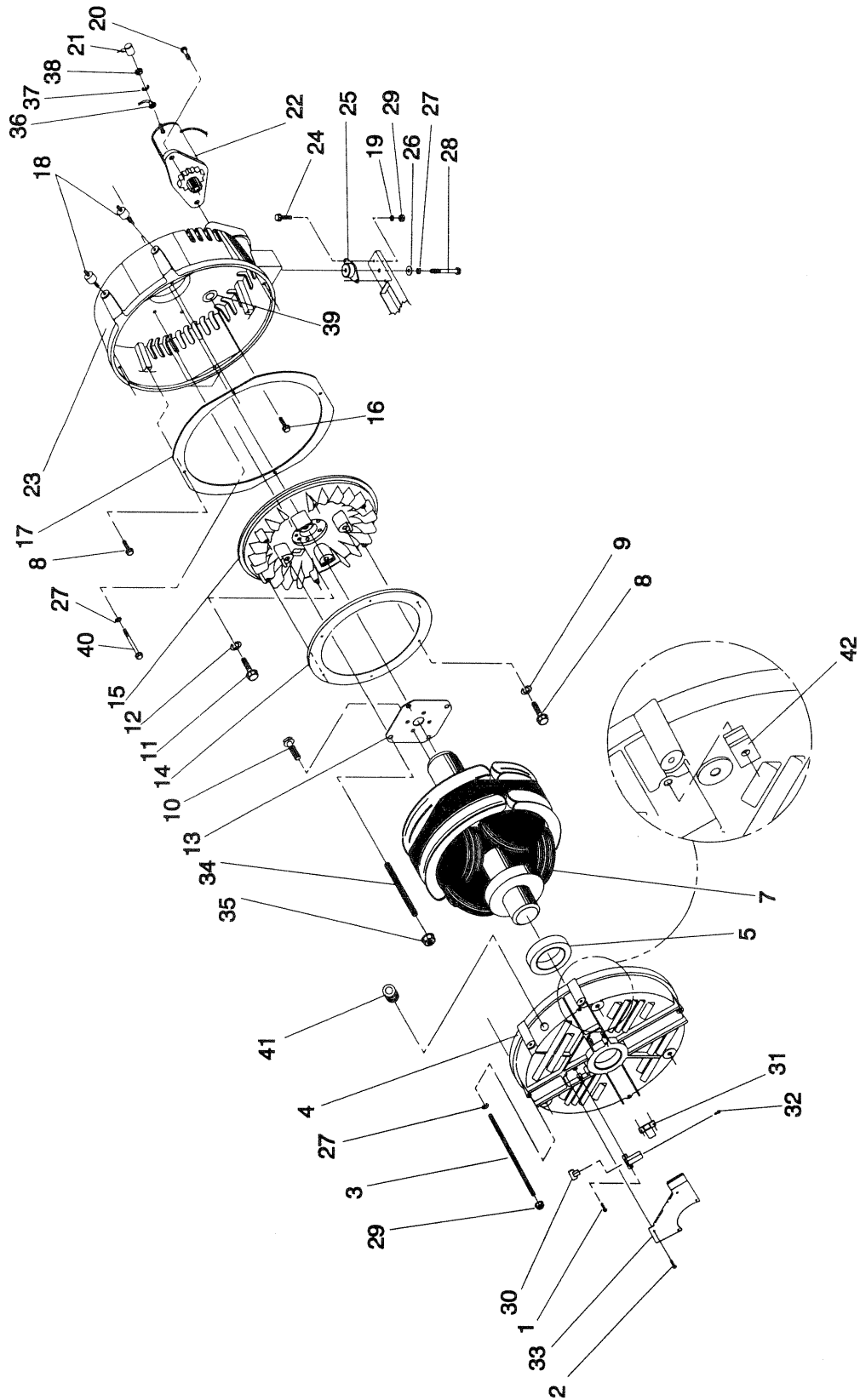

# REPAIR PARTS LIST — GENERATOR

Drawing No. C1273-A

ITEM	PART NO.	QTY.	DESCRIPTION
1	24488	4	TAPTITE #8 X 5/8"
2	24911	4	TAPTITE #8 X 3/8"
3	BN45761	4	STUD-M8-1.25 X 160 MM
4	81931	1	REAR BEARING CARRIER 15" RV
5	47248	1	BALL BEARING-45 MM
6	81956	1	ASM ROTOR 15" RV 2.5L
7	81955	1	ASM STATOR 15" RV 2.5L
8	45770	10	CAPSCREW, HEX HEAD-M5-0.80 X 10 MM
9	22152	6	LOCK WASHER #10
10	81974	4	HHFC/LW M8-1.25 X 20 MM
11	74066	4	HHCS, M10-1.25 X 30 MM
12	22302	4	LOCK WASHER-M10
13	81952	1	FLEX PLATE-15" RV 15M
14	81900	1	RING FAN
15	81192	1	FLYWHEEL MACH.-15" ISM
16	42911	4	CAPSCREW, HEX HEAD-M10-1.50 X 30 MM
17	81901	1	BAFFLE, AIR RING
18	82737	4	MOUNT, VIBRATION
19	22145	4	FLAT WASHER-5/16-M8
20	59450	2	CAPSCREW, SOCKET HEAD-5/16-18 X 1-1/4 LONG
21	75763	1	BOOT, BATTERY CABLE
22	20692	1	MOTOR, STARTER
23	C1271	1	ENGINE ADAPTOR-15", ISM 1L
24	39253	4	CAPSCREW, HEX HEAD-M8-1.25 X 20 MM
25	70936	2	VIBRATION ISOLATOR
26	71956	2	WASHER, VIBRATION ISOLATOR
27	22129	8	LOCK WASHER-5/16-M8
28	72553	2	SCREW, HEX HEAD-M8-1.25 X 60 MM
29	45771	8	HEX NUT, M8-1.25
30	A-24044-A	4	BRUSH ASSEMBLY
31	23877-D	2	HOLDER, BRUSH
32	25105	4	PRHMS 6-32 X 1/4" SIMS
33	82626	1	COVER, BRUSH
34	BM45761	4	STUD, M8-1.25 X 30 MM
35	52858	4	NUT FLANGE, HEX-M8-1.25
36	81991	1	WIRE ASSEM.-RED
37	22097	1	LOCK WASHER-1/4-M6
38	22127	1	NUT, HEX-1/4-20
39	22237	4	LOCK WASHER-3/8
40	42909	2	CAPSCR., HEX HD.-M8-1.25 X 30 MM
41	29107	1	GROMMET, RUBBER
42	25155	1	CLAMP

# CALIFORNIA AND FEDERAL EMISSION CONTROL WARRANTY STATEMENT

## YOUR WARRANTY RIGHTS AND OBLIGATIONS

The California Air Resources Board (CARB) and the United States Environmental Protection Agency (EPA), together with Generac Power Systems, Inc. (Generac), are pleased to explain the Emission Control System Warranty on your new engine.\* New utility, and lawn and garden equipment engines must be designed, built and equipped to meet stringent anti-smog standards for the state of California and the federal government. Generac will warrant the emission control system on your engine for the periods of time listed below provided there has been no abuse, neglect, unapproved modification or improper maintenance of your engine.

Your emission control system may include parts such as the carburetor, ignition and exhaust systems. Generac will repair your engine at no cost to you for diagnosis, replacement parts and labor, should a warrantable condition occur.

### MANUFACTURER'S EMISSION CONTROL SYSTEM WARRANTY COVERAGE:

Emissions control systems on 1997 and later model year engines are warranted for two years as hereinafter noted. If, during such warranty period, any emission-related component or system on your engine is found to be defective in materials or workmanship, repairs or replacement will be performed by a Generac Authorized Warranty Service Facility.

### PURCHASER'S/OWNER'S WARRANTY RESPONSIBILITIES:

As the engine purchaser/owner, you are responsible for the completion of all required maintenance as listed in your factory supplied *Owner's Manual*. For warranty purposes, Generac recommends that you retain all receipts covering maintenance on your engine. However, Generac cannot deny warranty solely because of the lack of receipts or for your failure to ensure the completion of all scheduled maintenance.

As the engine purchaser/owner, you should, however, be aware that Generac may deny any and/or all warranty coverage or responsibility if your engine, or a part/component thereof, has failed due to abuse, neglect, improper maintenance or unapproved modifications, or the use of counterfeit and/or 'grey market' parts not made, supplied or approved by Generac.

You are responsible for presenting your engine to a Generac Authorized Warranty Service Facility as soon as a problem occurs. The warranty repairs should be completed in a reasonable amount of time, not to exceed 30 days.

Warranty service can be arranged by contacting either Generac or a Generac Authorized Warranty Service Facility at the following address:

**GENERAC POWER SYSTEMS, INC. PH: (414) 544-4811  
P.O. BOX 8 FAX: (414) 544-0179  
WAUKESHA, WI 53187**

**IMPORTANT NOTE:** This warranty statement explains your rights and obligations under the Emission Control System Warranty (ECS Warranty), which is provided to you by Generac pursuant to California and federal law. See also the "Generac Limited Warranties for Generac Power Systems, Inc.," which is enclosed herewith on a separate sheet, also provided to you by Generac. The ECS Warranty applies **only** to the emission control system of your new engine. If there is any conflict in terms between the ECS Warranty and the Generac Warranty, the ECS Warranty shall apply except in circumstances where the Generac Warranty may provide a longer warranty period. Both the ECS Warranty and the Generac Warranty describe important rights and obligations with respect to your new engine.

Warranty service can be performed only by a Generac Authorized Warranty Service Facility. When requesting warranty service, evidence must be presented showing the date of the sale to the original purchaser/owner. The purchaser/owner shall be responsible for any expenses or other charges incurred for service calls and/or transportation of the product to/from the inspection or repair facilities. The purchaser/owner also shall be responsible for any and/or all damages or losses incurred while the engine is being transported/shipped for inspection or warranty repairs.

**If you have any questions regarding your warranty rights and responsibilities, you should contact Generac at (414) 544-4811.**

Part 1

## EMISSION CONTROL SYSTEM WARRANTY

Emission Control System Warranty (ECS Warranty) for 1997 and later model year engines:

- (a) **Applicability:** This warranty shall apply to 1997 and later model year engines. The ECS Warranty Period shall begin on the date the new engine or equipment is purchased by/delivered to its original, end-use purchaser/owner and shall continue for 24 consecutive months thereafter.
- (b) **General Emissions Warranty Coverage:** Generac warrants to the original, end-use purchaser/owner of the new engine or equipment, and to each subsequent purchaser/owner, that each of its engines is ...
- (1) Designed, built and equipped so as to conform with all applicable regulations adopted by the EPA and CARB pursuant to their respective authority, and
  - (2) Free from defects in materials and workmanship which, at any time during the ECS Warranty Period, may cause a warranted emissions-related part to fail to be identical in all material respects to the part as described in the engine manufacturer's application for certification.
- (c) The ECS Warranty only pertains to emissions-related parts on your engine, as follows:
- (1) Any warranted, emissions-related parts that are not scheduled for replacement as required maintenance in the *Owner's Manual* shall be warranted for the ECS Warranty Period. If any such part fails during the ECS Warranty Period, it shall be repaired or replaced by Generac according to Subsection (4) below. Any such part repaired or replaced under the ECS Warranty shall be warranted for the remainder of the ECS Warranty Period.
  - (2) Any warranted, emissions-related part that is scheduled only for regular inspection as specified in the *Owner's Manual* shall be warranted for the ECS Warranty Period. A statement in such written instructions to the effect of "repair or replace as necessary" shall not reduce the ECS Warranty Period. Any such part repaired or replaced under the ECS Warranty shall be warranted for the remainder of the ECS Warranty Period.
  - (3) Any warranted, emissions-related part that is scheduled for replacement as required maintenance in the *Owner's Manual* shall be warranted for the period of time prior to the first scheduled replacement point for that part. If the part fails prior to the first scheduled replacement, the part shall be repaired or replaced by Generac according to Subsection (4) below. Any such emissions-related part repaired or replaced under the ECS Warranty shall be warranted for the remainder of the ECS Warranty Period prior to the first scheduled replacement point for such emissions-related part.
  - (4) Repair or replacement of any warranted, emissions-related part under this ECS Warranty shall be performed at no charge to the owner at a Generac Authorized Warranty Service Facility.
  - (5) When the engine is inspected by a Generac Authorized Warranty Service Facility, the owner shall not be held responsible for diagnostic costs if the repair is deemed warrantable.
  - (6) Generac shall be liable for damages to other original engine components or approved modifications proximately caused by a failure under warranty of any emission-related part covered by the ECS Warranty.
  - (7) Throughout the ECS Warranty Period, Generac shall maintain a supply of warranted emission-related parts sufficient to meet the expected demand for such emission-related parts.
  - (8) Any Generac authorized and approved emission-related replacement part may be used in the performance of any ECS Warranty maintenance or repairs and will be provided without charge to the purchaser/owner. Such use shall not reduce Generac's ECS Warranty obligations.
  - (9) Unapproved, add-on, modified, counterfeit and/or 'grey market' parts may not be used to modify or repair a Generac engine. Such use voids this ECS Warranty and shall be sufficient grounds for disallowing an ECS Warranty claim. Generac shall not be held liable hereunder for failures of any warranted parts of a Generac engine caused by the use of such an unapproved, add-on, modified, counterfeit and/or 'grey market' part.

### EMISSION RELATED PARTS INCLUDE THE FOLLOWING:

- |   |   |
|---|---|
| 1) Fuel Metering System:  | 2) Air Induction System including:                        |
| 1.1) Gasoline carburetor assembly and its internal components (if so equipped). | a) Intake pipe/manifold                                   |
| a) Fuel filter (if so equipped)   | b) Air cleaner  |
| b) Carburetor gaskets   | 3) Ignition System including:                             |
| c) Fuel pump (if so equipped)   | a) Spark plug   |
| 1.2) LPG carburetion assembly and its internal components (if so equipped).     | b) Ignition module  |
| a) Fuel controller (if so equipped)   | 4) Catalytic Muffler Assembly (if so equipped) including: |
| b) Mixer and its gaskets (if so equipped)                                       | a) Muffler gasket   |
| c) Carburetor and its gaskets (if so equipped)                                  | b) Exhaust manifold                                       |
| d) Primary gas regulator (if so equipped)                                       | 5) Crankcase Breather Assembly including:                 |
| e) LP liquid vaporizer (if so equipped)   | a) Breather connection tube                               |

\*Generac engine types covered by this warranty statement include the following:

- 1) Utility
- 2) Lawn and Garden Equipment
- 3) Recreational Vehicle (RV) Generator
- 4) Industrial Mobile (IM) Generator

**Part 2**

## Generac's Three-Year Limited Warranty For Recreational Vehicle Generators

Generac warrants to the original owner and subsequent purchasers from the date of purchase by the original owner, that its generators will be free from defects in materials or workmanship for the period as set forth below. During said warranty period, Generac will, at its option, repair or replace any part which, upon examination by Generac or a Generac Authorized Distributor and/or Dealer thereof, is found to be defective from normal use and service.

This warranty is only effective, upon Generac's receipt from the original owner, a completed Warranty Registration Card, prior to the expiration of the warranty period. This card is the only valid registration identification and must be presented at time of requesting Warranty service. Claims will not be accepted without presentation of this Registration Card.

### THREE YEAR WARRANTY SCHEDULE

1. All generators used in a recreational vehicles shall be warranted for a period of three (3) years or 2,000 hours of operation, whichever occurs first. All parts, labor, removal and reinstallation shall be covered for the first two years. Parts and labor on selected generator and engine parts shall be covered during the third year or 2,000 hours, whichever occurs first. These selected parts are limited to: the main Rotor and Stator, Computer Control board (if applicable) with regard to the generator; the Cylinder Block, Cylinder Head, Crankshaft, Piston, Valve, Valve Lifter, and Manifolds with regard to the engine.
2. The drive belt and pulleys (if so equipped) on air-cooled generator used in recreational vehicles shall be warranted against failure due to defective materials or normal usage for the life of the generator. For the original owner, this drive belt and pulley warranty shall include parts and labor plus \$50.00 payment upon return of the failed belt or pulley by the original owner. For succeeding owners, this drive belt warranty shall cover belt or pulley parts only.
3. Rental units, demonstrators, prime power, or commercial applications, such as construction or utility, are warranted for (1) one year or 2,000 hours, whichever comes first.
4. This transferable warranty is in effect for all Recreational Vehicle Generators purchased after Jan. 1, 1998.

### THIS WARRANTY DOES NOT COVER:

- Costs of maintenance, installation, and start-up.
- Failures due to (a) normal wear and tear from GN engine, or (b) accident, misuse, abuse, negligence or improper installation.
- Products which are modified or altered in a manner not authorized by Generac in writing.
- Any incidental, consequential or indirect damages caused by defects in materials or workmanship, or any delay in repair or replacement of defective parts.
- Failure due to misapplication.
- Telephone, telegraph, teletype or other communication expense.
- Living or travel expenses of persons performing service.
- Any and all transportation/travel expenses.
- Rental equipment used while warranty repairs are being performed.
- Overtime labor.
- Starting batteries, fuses, light bulbs, and engine fluids.

**\*\*NORMAL WEAR: As with all mechanical devices, the GN-Series engines need periodic parts service and replacement to perform well. This warranty will not cover repair when normal use has exhausted the life of a part or an engine.**

There is no other express warranty. Generac hereby disclaims any and all implied warranties, including but not limited to those of merchantability and fitness for a particular purpose to the extent permitted by law. The duration of any implied warranties which cannot be disclaimed is limited to the time period (one year) as specified in the express warranty. Liability for consequential, incidental or special damages under any and all warranties is excluded to the extent permitted by law. Some states do not allow limitations on how long an implied warranty lasts, or the exclusion or limitation of incidental or consequential damages, so the above limitations or exclusions may not apply to you. This warranty gives you specific legal rights and you may also have other rights, which vary from state to state.

For service, see your nearest GENERAC authorized warranty service facility or call 1-800-526-2871. Warranty service can be performed only by a GENERAC authorized service facility. This warranty will not apply to service at any other facility. At the time of requesting warranty service, evidence of original purchase date must be presented.

**Generac Power Systems, Inc.  
P.O. Box 8 • Waukesha, WI 53187  
Telephone: (414) 473-5514 Fax: (414) 472-6505**



## Free Manuals Download Website

<http://myh66.com>

<http://usermanuals.us>

<http://www.somanuals.com>

<http://www.4manuals.cc>

<http://www.manual-lib.com>

<http://www.404manual.com>

<http://www.luxmanual.com>

<http://aubethermostatmanual.com>

Golf course search by state

<http://golfingnear.com>

Email search by domain

<http://emailbydomain.com>

Auto manuals search

<http://auto.somanuals.com>

TV manuals search

<http://tv.somanuals.com>