



Pro Unit

Owner/Operator Manual

Models

- 988100 - GR1336FX
- 988101 - GR1536FX
- 988102 - GR1548FX
- 988103 - GR1548FL
- 988104 - GE1748FL
- 988110 - GR1332FX
- 988112 - GR1544FX
- 988114 - GR1336FXP
- 988115 - GR1548FXP
- 988118 - GR1332FXP
- 988119 - GR1544FXP
- 988313 - GR1332FXPCE

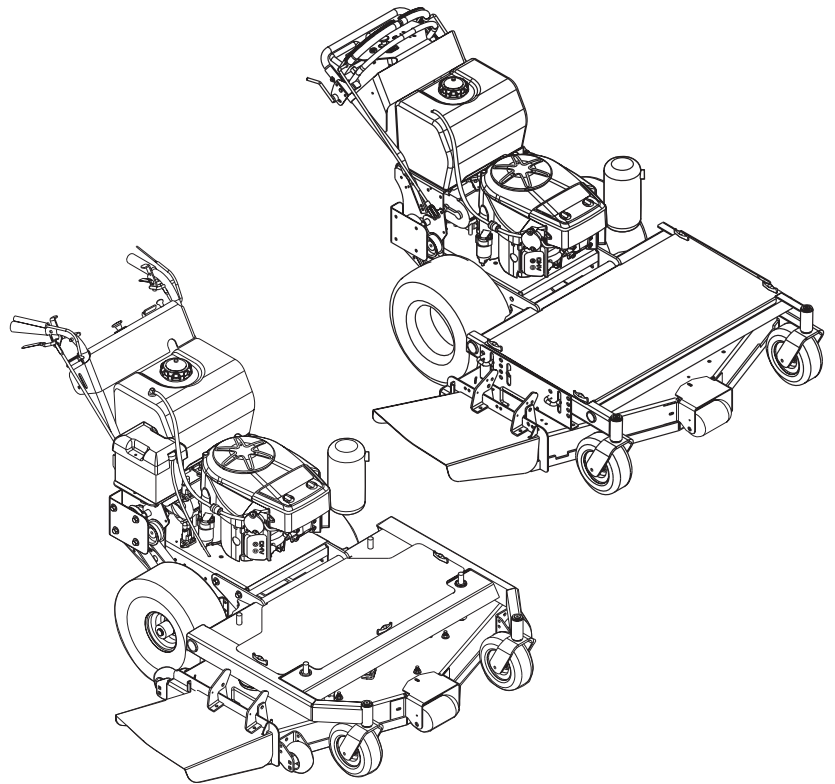

- GB ENGLISH
- F FRANÇAIS
- E ESPAÑOL

04941300 7/03
Printed in USA



Ariens Company
 655 West Ryan Street
 P.O. Box 157
 Brillion, Wisconsin 54110-0157
 USA
 Telephone (920) 756-2141
 Facsimile (920) 756-2407

MODEL DECLARATION OF CONFORMITY ISSUED BY THE MANUFACTURER
 CERTIFICAT DE CONFORMITÉ DU MODÈLE DÉLIVRÉ PAR LE FABRICANT
 VOM HERSTELLER AUSGESTELLTE
 MODELL-ÜBEREINSTIMMUNGSERKLÄRUNG
 MODEL CERTIFICAAT VAN OVEREENSTEMMING AFGEGEVEN DOOR DE FABRIKANT
 DICHIARAZIONE DI CONFORMITÀ DEL PRODOTTO REALIZZATA DAL PRODUTTORE

MODELO DE DECLARACIÓN DE CONFORMIDAD EMITIDA POR EL FABRICANTE
 MODEL KONFORMITETSERKLÆRING UDSTEDT AF FABRIKANTEN
 MODELLENS SAMSVARERKLÆRING UTFERDIGET AV PRODUSENTEN
 FÖRSÄKRAN OM MODELLÖVERENSSTÄMMELSE, UTFÄRDAT AV TILLVERKAREN

We the undersigned, - Je soussigné, - Mit meiner Unterschrift - Wij de ondergetekenden, - Il sottoscritto, - El abajo firmante - Undertegnede, - Undertecknaren av detta dokument, - Me, allekirjoittaneet,

ARIENS COMPANY, declare that the Lawn Mower- certifie que la tondeuse à gazon - erklärt, dass der Rasenmäher - verklaart dat de maaitrekker - dichiara che il tosaerba - certifica que el cortacésped - erklærer, at græsslåmaskinen - erklærer at plenklipperen - intygar att gräsklipparen:

Category: **WALK BEHIND LAWN MOWER**

Make and Trade Name: **GRAVELY**

Model: 988313

Serial #Range: 00101 & up

Cutting Width (cm): 80.6

conform to the specifications of directive 2000/14/EC, 98/37/EC, 89/336/EEC and their current amendments.
 est conforme aux spécifications des directives 2000/14/EC, 98/37/EC et 89/336/EEC et à leurs modifications actuelles.

den Spezifikationen der Richtlinie 2000/14/EC, 98/37/EC, 89/336/EEC und deren aktuellen Zusätzen entspricht.
 voldoet aan de specificaties van richtlijn 2000/14/EG, 98/37/EG, 89/336/EEG en recente aanvullingen hierop.
 è conforme alle specifiche contenute nelle direttive 2000/14/EC, 98/37/EC, 89/336/EEC e nei loro relativi emendamenti.

cumple las especificaciones de la normativa 2000/14/EC, 98/37/EC, 89/336/EEC y sus enmiendas en curso.
 opfylder spesifikationerne i Direktiv 2000/14/EF, 98/37/EF, 89/336/EØF og gældende ændringer.
 er i overensstemmelse med spesifikasjonene i direktiv 2000/14/EF, 98/37/EF, 89/336/EØF og de gjeldende endringer.

överensstämmer med specifikaionerna i direktiven 2000/14/EC, 98/37/EC, 89/336/EEC och deras nuvarande tillägg.

Representative Measured Sound Power Level - Niveau de puissance acoustique représentatif Repräsentativer gemessener Geräuschpegel Typisch gemeten geluidssterkteniveau Livello di potenza sonora rappresentativo rilevato Nivel de potencia acústica representativo medido Repræsentativt målt lydstyrkeniveau Representativt målt lydeffektnivå Representativ uppmått ljudnivå	99 dB _A	Guaranteed Sound Power Level - Niveau garanti de puissance acoustique Garantierter Geräuschpegel Gegarandeerd geluidssterkteniveau Livello di potenza sonora garantito Nivel de potencia acústica garantizado Garanteret lydstyrkeniveau Garantert lydeffektnivå Garanterad ljudnivå	100 dB _A
---	--------------------	--	---------------------

Stated Sound Power Levels are established following Annex VIII "Full Quality Assurance" of directive 2000/14/EC. Les déclarations de niveau de puissance acoustique sont établies conformément à l'Article VIII « Assurance qualité totale » de la directive 2000/14/EC.

Die angegebenen Geräuschpegel wurden gemäß Anhang VIII „Totales Qualitäts-Management“ der EU-Richtlinie 2000/14/EC.

Gespecificieerde geluidssterkteniveaus zijn vastgesteld aan de hand van Annex VIII "Full Quality Assurance" (Volledige kwaliteitsborging) van richtlijn 2000/14/EG.

I livelli di potenza sonora dichiarati sono rilevati in base all'Appendice VIII del "Controllo qualità totale" della direttiva CE/2000/14.

Los niveles de potencia acústica se establecen siguiendo el Anexo VIII "Garantía de calidad total" de la directiva 2000/14/EC.

De anførte lydstyrkeniveauer er fastlagte efter tillæg VIII "Fuld kvalitets sikring" i direktiv 2000/14/EF.

Lydeffektnivåene er fastsatt etter tillegg VIII "Full kvalitetssikring" i direktivet 2000/14/EF.

Fastställda ljudnivåer har etablerats enligt bilaga VIII "Full kvalitetssäkring" i direktiv 2000/14/EC.

Notified Body – SNCH/TUV Rheinland

Entité notifiée – Benachrichtigte Körperschaft – 11, Route de Luxembourg

Certificeringsinstantie – Organismo notificato – L-5230 Sandweiler

Cuerpo notificado – Bekendtgjort til – Kunngjøring til –
Underrättad myndighet –

Keeper of Technical File- Philip J. Smucker

Dépositaire du fichier technique - Verwalter der
technischen Dokumente - Houder technische
gegevens - Depositario del file tecnico -
Depositario del archivo técnico - Ansvarlig for
teknisk data - Ansvarlig for teknisk
dokumentasjon - Innehavare of teknisk fil -

Signature/Unterschrift/
Handtekening/Firma/
Underskrift/Underskrift
Handlekening/Under-
skrift/Allekirjoitus

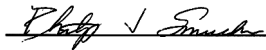

Philip J. Smucker
Manager of Product Conformance
Position/Qualité/Functie/Qualifica/Puesto/Stilling/Titel/Arvo
Ariens Company

6/11/03

Date/Datum/Dat
a/Fecha/Dato/P
äiväys

 **WARNING** 

The engine exhaust from this product contains chemicals known to the State of California to cause cancer, birth defects or other reproductive harm.

CONTROLS AND FEATURES

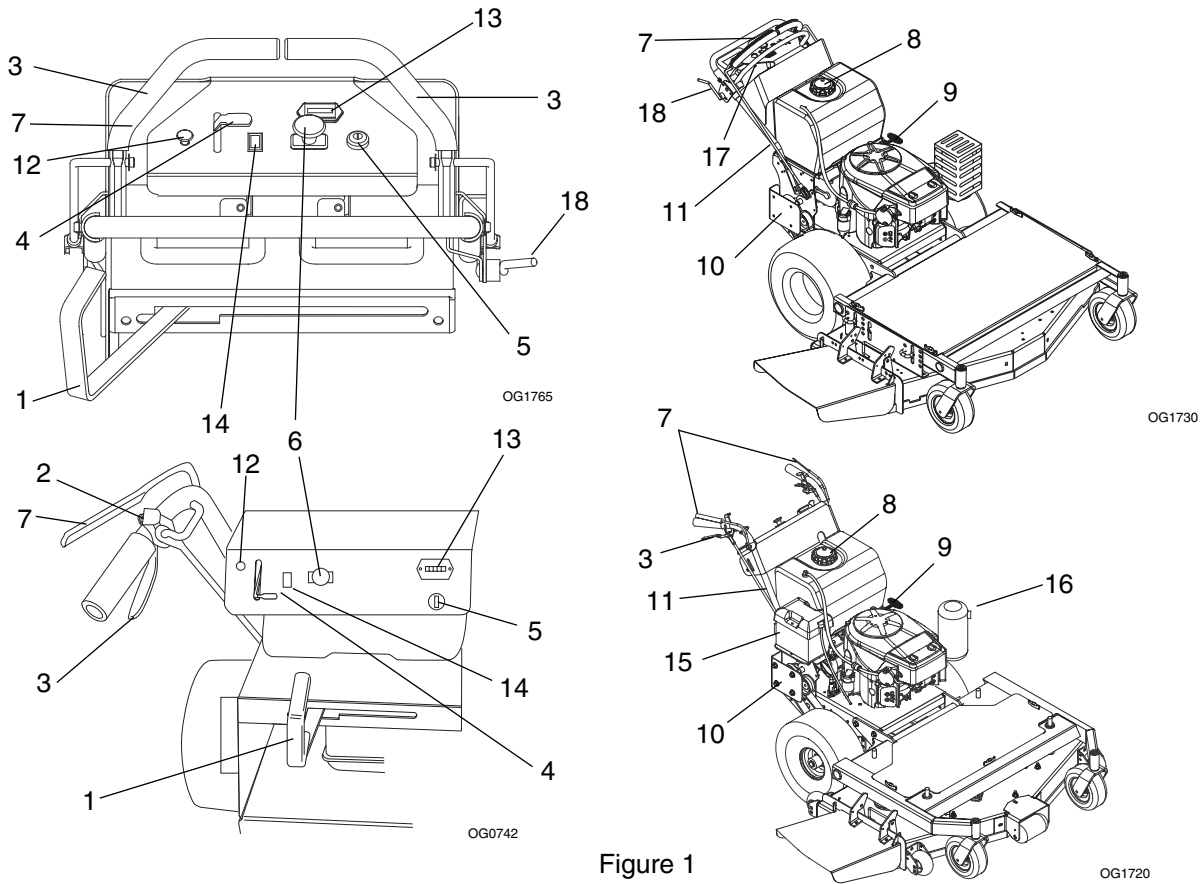

Figure 1

ENGLISH

1. Shift Lever
2. Steering Lever Latches (988100, 101, 102, 103, 104, 110, 112)
3. Steering Levers (988100, 101, 102, 103, 104, 110, 112)
Control Levers (988114, 115, 118, 119, 313)
4. Throttle Lever (988101, 102, 103, 104, 112, 115, 119)
Throttle-Choke Lever (988100, 114, 110, 118, 313)
5. Ignition Switch
6. PTO Switch
7. Operator Presence Controls
8. Fuel Cap
9. Recoil Starter Handle
10. Traction Belt Guard
11. Handlebar
12. Choke Control (988101, 102, 103, 104, 112, 115, 119)
13. Hour Meter
14. Oil Light (988104)
15. Battery (988104)
16. Muffler Guard (988313)

17. Pivot Bar (988114, 115, 118, 119, 313)
18. Control Stop Lock Lever (988114, 115, 118, 119, 313)

FRANÇAIS

1. Levier de vitesses
2. Verrous de la poignée de direction (988100, 101, 102, 103, 104, 110, 112)
3. Poignées de direction (988100, 101, 102, 103, 104, 110, 112)
Leviers de commande (988114, 115, 118, 119, 313)
4. Manette des gaz (988101, 102, 103, 104, 112, 115, 119)
Manette des gaz – Starter (988100, 114, 110, 118, 313)
5. Clé de contact
6. PdF
7. Commandes de présence de l'opérateur
8. Bouchon du réservoir de carburant
9. Poignée du démarreur à cordon
10. Garant de courroie

11. Guidon
12. Commande du starter (988101, 102, 103, 104, 112, 115, 119)
13. Compteur horaire (988104)
14. Voyant de l'huile (988104)
15. Batterie (988104)
16. Garant du silencieux (988313)
17. Barre de pivot (988114, 115, 118, 119, 313)
18. Levier de verrouillage de butée de commande (988114, 115, 118, 119, 313)

ESPAÑOL

1. Palanca de cambios
2. Trabas de las palancas de la dirección (988100, 101, 102, 103, 104, 110, 112)
3. Palancas de dirección (988100, 101, 102, 103, 104, 110, 112)
Palancas de control (988114, 115, 118, 119, 313)
4. Palanca del acelerador (988101, 102, 103, 104, 112, 115, 119)
Palanca del acelerador-estrangulador (988100, 110, 114, 118, 313)
5. Interruptor de encendido
6. Palanca de la TDF
7. Controles de presencia del operador
8. Tapón del combustible
9. Manilla de arranque de retroceso
10. Protección de la correa de tracción
11. Manillar
12. Control de estrangulamiento (988101, 102, 103, 104, 112, 115, 119)
13. Horómetro (988104)
14. Luz del aceite (988104)
15. Batería (988104)
16. Protector del silenciador (988313)
17. Barra de pivote (988114, 115, 118, 119, 313)
18. Palanca de control de traba por tope (988114, 115, 118, 119, 313)

TABLE OF CONTENTS

Controls and Features	4	Storage	25
Safety	6	Troubleshooting	25
Assembly	10	Accessories	26
Operation	10	Service Parts	26
Maintenance	17	Specifications	27
Service and Adjustments	18	Warranty	29

INTRODUCTION

THE MANUAL

Before operation of unit, carefully and completely read your manuals. The contents will provide you with an understanding of safety instructions and controls during normal operation and maintenance.

All reference to left, right, front, or rear are given from operator standing in operation position and facing the direction of forward travel.

MODEL AND SERIAL NUMBERS

Transfer model & serial number label from product registration here.

When ordering replacement parts or making service inquiries, know the Model and Serial numbers of your unit and engine.

Numbers are located on the product registration form in the unit literature package. They are printed on a serial number label, located on the frame of your unit.

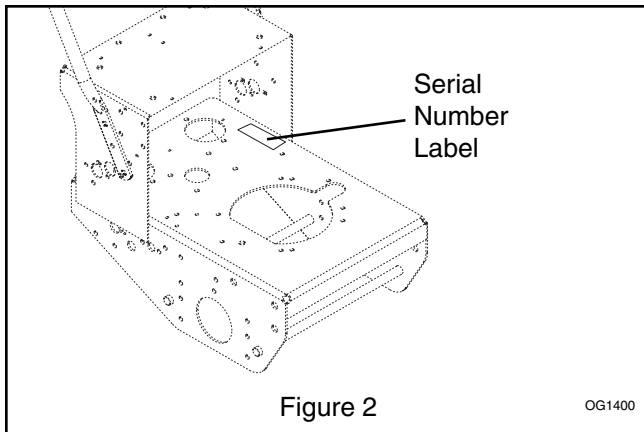

- Record Engine Model and Serial numbers here.

PRODUCT REGISTRATION

The Gravelly dealer must register the product at the time of purchase. Registering the product will help the company process warranty claims or contact you with the latest service information. All claims meeting requirements during the limited warranty period will be honored, whether or not the product registration card is returned. Keep a proof of purchase if you do not register your unit.

Customer Note: If Dealer does not register your product, please fill out, sign and return the product registration card to Gravelly.

UNAUTHORIZED REPLACEMENT PARTS

Use only Gravelly replacement parts. The replacement of any part on this vehicle with anything other than a Gravelly authorized replacement part may adversely affect the performance, durability, or safety of this unit and may void the warranty. Gravelly disclaims liability for any claims or damages, whether warranty, property damage, personal injury or death arising out of the use of unauthorized replacement parts. To locate your nearest Gravelly Dealer, call 1-800-472-8359 or go to www.gravelly.com on the internet.

DISCLAIMER

Gravelly reserves the right to discontinue, make changes to, and add improvements upon its products at any time without public notice or obligation. The descriptions and specifications contained in this manual were in effect at printing. Equipment described within this manual may be optional. Some illustrations may not be applicable to your unit.

DEALER DELIVERY

Dealer should:

1. Check all controls for proper function.
2. Check the safety interlock system to make sure that it is functioning properly. (See *Check Safety Interlock System* on page 17.)
3. Fill out Original Purchaser Registration Card and return the card to Gravelly.
4. Explain Limited Warranty Policy.

5. Explain recommended lubrication and maintenance. Advise customer on adjustments.

6. Instruct customer on controls and operation of unit. Discuss and emphasize the Safety Precautions. Give customer Owner/Operator, Parts, and Engine Manuals. Advise customer to thoroughly read and understand them.

SAFETY



WARNING: This cutting machine is capable of amputating hands and feet and throwing objects. Failure to observe the safety instructions in the manuals and on decals could result in serious injury or death.

Slopes are a major factor related to loss-of-control and tip-over accidents. Operation on all slopes requires extra caution.

Tragic accidents can occur if the operator is not alert to the presence of children. Never assume that children will remain where you last saw them.

Gasoline is extremely flammable and the vapors are explosive, handle with care.

Disengage attachment, stop unit and engine, remove key, engage parking brake, and allow moving parts to stop before leaving operator's position.

SAFETY ALERTS



Look for these symbols to point out important safety precautions. They mean:

Attention!



Personal Safety Is Involved!

Become Alert!

Obey The Message!

The safety alert symbols above and signal words below are used on decals and in this manual.

Read and understand all safety messages.



DANGER: IMMINENTLY HAZARDOUS SITUATION! If not avoided, **WILL RESULT** in death or serious injury.



WARNING: POTENTIALLY HAZARDOUS SITUATION! If not avoided, **COULD RESULT** in death or serious injury.



CAUTION: POTENTIALLY HAZARDOUS SITUATION! If not avoided, **MAY RESULT** in minor or moderate injury. It may also be used to alert against unsafe practices.

NOTATIONS

NOTE: General reference information for proper operation and maintenance practices.

IMPORTANT: Specific procedures or information required to prevent damage to unit or attachment.

PRACTICES AND LAWS

Practice usual and customary safe working precautions, for the benefit of yourself and others. Understand and follow all safety messages. Be alert to unsafe conditions and the possibility of minor, moderate, or serious injury or death. Learn applicable rules and laws in your area, including those that may restrict the age of the operator.

REQUIRED OPERATOR TRAINING

Original purchaser of this unit was instructed by the seller on safe and proper operation. If unit is to be used by someone other than original purchaser; loaned, rented or sold, **ALWAYS** provide this manual and any needed safety training before operation.

SAFETY DECALS AND LOCATIONS

ALWAYS replace missing or damaged Safety Decals. Refer to figures below for Safety Decal locations.

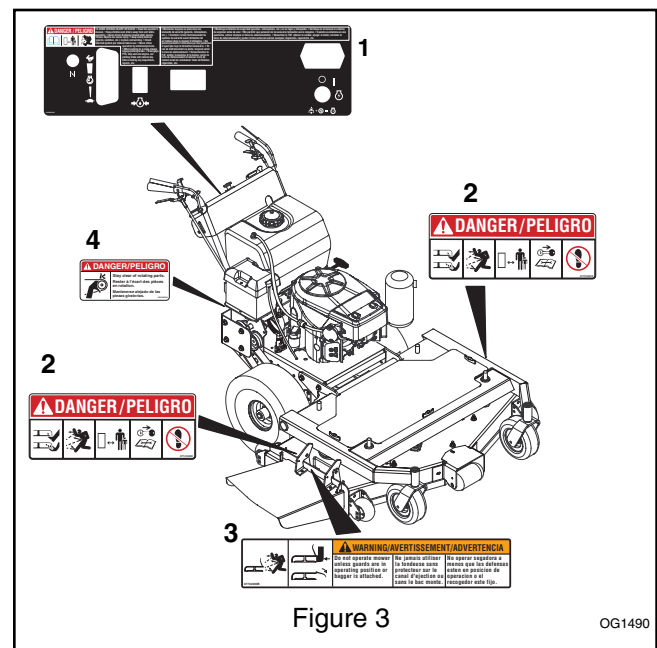

Figure 3

OG1490

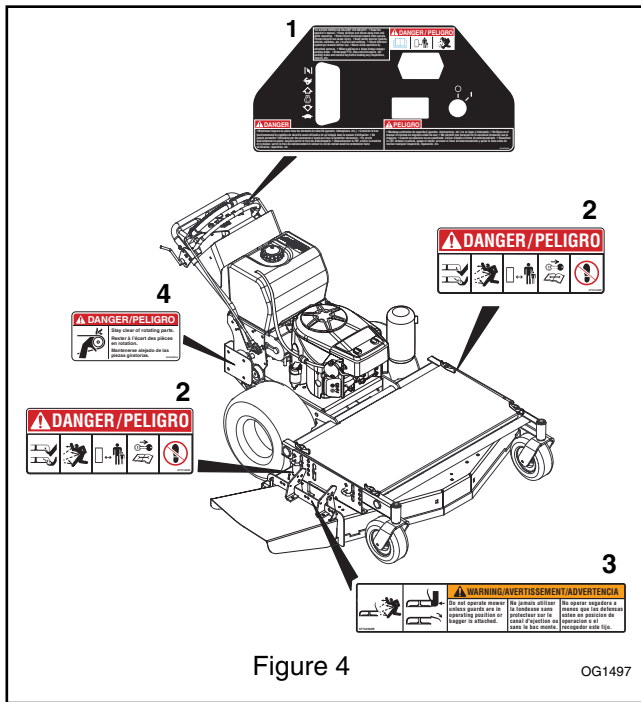

Figure 4

OG1497

1. Danger! To avoid serious injury or death



OL1801

Read the operator's manual.

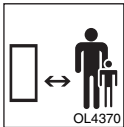

OL4370

Keep children and others away from unit while operating.



OL0910

Never direct discharge toward other people. Thrown objects can cause injury.

- Keep safety devices (guards, shields, switches, etc.) in place and working.
- Check interlock system per manual before use.
- Never allow operation by untrained persons.
- When parking on a slope always chock or block the wheels.
- Disengage PTO, stop unit and engine, set parking brake and remove key before making any inspections, repairs, etc.

2. Danger! Rotating Blades



OL3030

ROTATING BLADE! Keep hands and feet away.



OL0910

Always stand clear of discharge area. DO NOT direct discharge toward other people. Remove objects that could be thrown by the blade. DO NOT operate mower over gravel and hard surfaces.

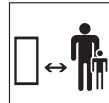

OL4370

Keep people and pets away when operating unit. Keep children out of the work area and under the watchful care of a responsible adult.



OL4010

Shut off engine, remove key, read manual before you unplug, adjust or repair unit.



OL4420

NO STEP! Always keep feet away from rotating parts.

3. Warning!



OL0910

Always stand clear of discharge.

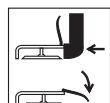

OL3320

DO NOT operate mower unless guards are in operating position or bagger is attached.

4. Danger!



OL5100

Stay clear of rotating parts.

SAFETY RULES

Read, understand and follow all safety practices in Owner/Operator Manual before beginning assembly. Failure to follow instructions could result in personal injury and/or damage to unit.

ALWAYS remove key (if equipped) and disconnect wire from spark plug before assembly. Unintentional engine start up can cause death or serious injury.

Complete a walk around inspection of unit and work area to understand:

- Work area
- Your unit
- All safety decals

ALWAYS check overhead and side clearances carefully before operation.

ALWAYS be aware of traffic when operating along streets or curbs.

Keep children and people away.

Keep children out of work area and under watchful care of a responsible adult.

Keep area of operation clear of all toys, pets, and debris. Thrown objects can cause injury.

Check for weak spots on docks, ramps or floors. Avoid uneven work areas and rough terrain.

ALWAYS be sure of your footing. Keep a firm hold on handlebar. Walk, NEVER run.

DO NOT operate on wet grass.

Dust, smoke, fog, etc. can reduce vision and cause an accident. Operate unit only when there is good visibility and light.

Read the entire Owner/Operator manual and other training material. If the operator or the mechanic cannot read the manual, it is the owner's responsibility to explain it to them. Only the user can prevent and is responsible for accidents or injuries occurring to themselves, other people or property.

- Only trained adults may operate or service unit
- Training includes actual operation

NEVER allow children to operate or play on or near unit.

Be alert and shut off unit if children enter area.

Never carry passengers.

NEVER operate unit after or during the use of medication, drugs or alcohol. Safe operation requires your complete and unimpaired attention at all times.

NEVER allow anyone to operate this unit when their alertness or coordination is impaired.

Wear adequate safety gear, protective gloves and footwear.

NEVER wear open sandals or canvas shoes during operation.

Protect eyes, face and head from objects that may be thrown from unit. Wear appropriate hearing protection.

Sharp edges can cut. Moving parts can cut off fingers or a hand. Wrap blade(s), wear sturdy gloves and use extreme caution when servicing. On multi-blade mowers, rotation of one blade will cause all blades to rotate.

ALWAYS keep hands and feet away from all rotating parts during operation. Rotating parts can cut off body parts.

ALWAYS keep hands away from all pinch points.

DO NOT touch unit parts which might be hot from operation. Allow parts to cool before attempting to maintain, adjust or service.

NEVER place your hands or any part of your body or clothing inside or near any moving part while unit is running.

DO NOT wear loose clothing or jewelry. Tie back hair that may get caught in rotating parts.

Keep children and people away from unit during operation.

Fumes from engine exhaust can cause injury or death.

DO NOT run engine in an enclosed area. Always provide good ventilation.

Thrown objects can cause injury and property damage. DO NOT point discharge at anyone or discharge directly onto paved or gravel surfaces.

Always stand clear of the discharge area when operating this unit.

Read, understand, and follow all instructions in the manual and on the machine before starting.

Understand:

- How to operate all controls
- The functions of all controls
- How to STOP in an Emergency
- Braking and steering characteristics
- Turning radius and clearance

ALWAYS keep protective structures, guards, and panels in good repair, in place and securely fastened.

NEVER modify or remove safety devices.

ALWAYS keep discharge cover or complete grass catcher in place and in proper working condition.

Check steering control operation frequently. Adjust and service as required.

Safety Interlock System must function properly. DO NOT operate unit if operator presence control is damaged or disabled.

If you strike an object, or if equipment vibrates abnormally, stop engine at once, disengage PTO, wait for all moving parts to stop, and remove key. Check for any damage or loose parts. Repair before restart.

Before starting engine: disengage PTO and place unit in neutral.

DO NOT operate at too fast a rate. DO NOT change engine governor settings or over-speed engine. Slow down and turn corners slowly.

Disengage PTO when attachment is not in use. DO NOT raise deck with blades running. ALWAYS turn off power to attachment when travelling, crossing driveways, etc.

Avoid uneven and rough terrain. DO NOT operate near drop offs, ditches, or embankments. Unit can suddenly turn over if a wheel is over the edge of a cliff or ditch, or if an edge caves in.

DO NOT try to stabilize unit by putting foot on ground when operating with applicable riding attachments.

When engine is running and speed control lever is forward, holding only one steering lever will cause unit to circle around one drive wheel.

Use care when approaching blind corners, shrubs, trees or other objects that may obscure view.

ALWAYS disengage PTO, stop unit and engine, remove key and allow moving parts to stop before clearing clogs or cleaning unit.

Never leave a running unit unattended. ALWAYS shut off engine before leaving unit.

ALWAYS remove key to prevent unauthorized use.

DO NOT operate in reverse unless absolutely necessary. ALWAYS backup slowly. ALWAYS look down and behind, before and while backing.

DO NOT operate on steep slopes. DO NOT operate on slopes of more than 10°. Operate across the face of slopes, not up and down.

Turf conditions can affect the unit's stability.

Keep all movement on slopes slow and gradual. DO NOT make sudden changes in speed or direction. Use a slow speed to avoid stopping or shifting on slopes. Avoid starting or stopping on a slope.

DO NOT park unit on a slope unless absolutely necessary. When parking on a slope always chock or block wheels.

Use extra care when loading or unloading unit onto trailer or truck.

Secure unit chassis to transport vehicle. NEVER secure from rods or linkages that could be damaged.

DO NOT transport machine while engine is running.

Keep unit free of grass, leaves, or other debris. Clean up oil or fuel spills.

This product is equipped with an internal combustion engine. DO NOT use on or near any unimproved, forest covered or brush covered land unless the exhaust system is equipped with a spark arrester meeting applicable local, state or federal laws. A spark arrester, if used, must be maintained in effective working order by the operator.

Fuel is highly flammable and its vapors are explosive. Handle with care. Use an approved fuel container.

No smoking, No sparks, No flames. ALWAYS allow engine to cool before servicing.

NEVER fill fuel tank when engine is running or hot from operation.

NEVER fill or drain fuel tank indoors.

Replace fuel cap securely and clean up spilled fuel.

Never fill containers inside a vehicle or on a truck or trailer bed with a plastic liner. Always place containers on the ground away from your vehicle before filling.

When practical, remove gas-powered equipment from the truck or trailer and refuel it on the ground. If this is not possible, then refuel such equipment on a trailer with a portable container, rather than from a gasoline dispenser nozzle.

Keep the nozzle in contact with the rim of the fuel tank or container opening at all times until fueling is complete. Do not use a nozzle lock-open device.

If fuel is spilled on clothing, change clothing immediately.

NEVER store fuel inside where there is an open flame, such as a water heater.

Avoid Electric Shock. Objects contacting both battery terminals at the same time may result in injury and unit damage. DO NOT reverse battery connections.

Reverse connections may result in sparks which can cause serious injury. Always connect positive (+) lead of charger to positive (+) terminal, and negative (-) lead to negative (-) terminal.

ALWAYS disconnect negative (-) cable FIRST and positive (+) cable SECOND. ALWAYS connect positive (+) cable FIRST, and negative (-) cable SECOND.

Explosive Gases from battery can cause death or serious injury. Poisonous battery fluid contains sulfuric acid and its contact with skin, eyes or clothing can cause severe chemical burns.

No flames, No sparks, No smoking near battery.

ALWAYS wear safety glasses and protective gear near battery. Use insulated tools.

DO NOT TIP battery beyond a 45° angle in any direction.

ALWAYS keep batteries out of reach of children.

Battery posts, terminals and related accessories contain lead and lead compounds, chemicals known to the State of California to cause cancer and reproductive harm. Wash hands after handling.

Reverse connections may cause sparks which may result in injury. ALWAYS connect/disconnect cables in proper order.

Poisonous battery fluid contains sulfuric acid and its contact with skin, eyes, or clothing can cause severe burns.

Explosive Gases! No flames, No sparks, No smoking near battery.

ALWAYS wear safety glasses and protective gear near battery.

DO NOT TIP battery beyond a 45° angle in any direction.

ALWAYS keep batteries out of reach of children.

Before making any inspections, repairs, etc.: disengage PTO, stop unit and engine, remove key, allow moving parts to stop.

Allow hot parts to cool.

ALWAYS block wheels, engage parking brake and know all jack stands are strong, secure and will hold weight of unit during maintenance.

An extension spring, when extended, stores energy and can be dangerous. Always use tools specifically designed for installing or removing an extension spring. Always compress or extend springs slowly.

ALWAYS maintain unit in safe operating condition. Damaged or worn out muffler can cause fire or explosion.

Keep hardware, especially blade attachment bolts, tight.

Maintain or replace safety and instruction labels, as necessary.

For unit storage or extended storage:

- NEVER store with fuel in fuel tank, inside a building where any ignition sources are present.
- Allow engine to cool completely.

Use only attachments or accessories designed for your unit and that can be used safely on your terrain.

Check attachment components frequently for wear, damage or deterioration. Replace with manufacturer's recommended parts for safety.

To reduce fire hazard and overheating, keep equipment free of grass, leaves, debris or excessive lubricants.

Use extra care with grass catchers and other attachments. These can change the stability of the unit. Use only approved hitch points.

ALWAYS be aware of attachments when turning. ALWAYS allow adequate clearance between attachments, personnel, and other objects.

ASSEMBLY



WARNING: AVOID INJURY. Read and understand the entire *Safety* section before proceeding.

1. Remove the unit from shipping container.
2. Adjust tire pressure to 8 to 16 psi (55 to 110 kPa).
3. Service and connect battery. See *Charge Battery* on page 22.
4. Check the adjustments outlined in *Service & Adjustments*.

5. Check engine oil level. See engine manual.
6. Add clean fuel to the fuel tank. See engine manual for type and grade.
7. Check for loose hardware.
8. Be sure that safety interlock system operates correctly. See *Check Safety Interlock System* on page 17.
9. Be sure that unit tracks straight.
Unit must not pull sharply to the left or right when the steering levers are released. See *Adjusting the Unit to Track Straight* on page 18.

OPERATION



WARNING: AVOID INJURY. Read and understand the entire *Safety* section before proceeding.

CONTROLS AND FEATURES

Safety Interlock System



DANGER: SAFETY INTERLOCK SYSTEM FAILURE and improper operation of unit can result in death or serious injury. ALWAYS know the safety interlock system is operating properly. See *Check Safety Interlock System* on page 17 for testing instructions.

The engine will only start with the PTO disengaged. Pistol grip models must have the shift lever in neutral for engine to start.

Operator Presence Control (988100, 101, 102, 103, 104, 110, 112)

The operator presence control lever must be depressed to operate the PTO or traction drive. When the shift lever or PTO is engaged, releasing the operator presence control lever stops the engine.

Operator Presence Control (988114, 115, 118, 119, 313)

The operator presence control levers must be depressed to operate the PTO. When the PTO is engaged, releasing the operator presence control levers stops the mower blades.



CAUTION: AVOID INJURY. Operate only when operator presence control is functioning correctly. See *Check Safety Interlock System* on page 17 for testing instructions.

Steering Levers (988100, 101, 102, 103, 104, 110, 112)



WARNING: AVOID INJURY. When the engine is running and the shift lever is engaged, releasing only one steering latch causes the unit to circle around one drive wheel.

ALWAYS hold both steering levers in the neutral position when releasing the steering lever latches.

ALWAYS release levers slowly.

The steering levers are used to steer, operate in forward and reverse, and stop the unit. When held in neutral, the brakes are engaged.

Steering Lever Latches (988100, 101, 102, 103, 104, 110, 112)

The steering lever latches hold the steering levers in neutral and apply the brakes.

Control Levers (988114, 115, 118, 119, 313)



WARNING: AVOID INJURY. When the engine is running and the shift lever is engaged, moving only one lever causes the unit to circle around one drive wheel.

ALWAYS move levers slowly.

The control levers are used to steer, operate in forward and reverse, and stop the unit. Push forward to move forward. Shift into reverse and pull up on the lower control levers to move in reverse. When held in neutral, the brakes are engaged.

Ignition Switch (988104)

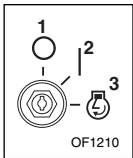

Operate the ignition switch with the removable key. The switch has three positions: Off (1), On (2) and Start (3). To start the engine, turn the key to Start, then release to On. To stop the engine, turn the key to Off.

Ignition Switch (988100, 101, 102, 103, 110, 112, 114, 115, 118, 119, 313)

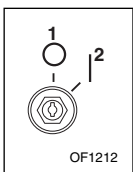

Operate the ignition switch with the removable key. The switch uses two positions: Off (1) and On (2). To start the engine, turn the key to On (2) and pull the recoil handle. To stop the engine, turn the key to Off (1).

Throttle Lever

(988101, 102, 103, 104, 112, 115, 119)



The throttle lever changes the speed of the engine. Move the throttle lever to Fast (1) to increase engine speed. Move the lever to Slow (2) to decrease engine speed.

Throttle/Choke Lever

(988100, 110, 114, 118, 313)



The Throttle/Choke lever changes the speed of the engine and chokes the engine for cold starts. Place the lever in Choke (1) to start a cold engine. Move the lever to Fast (2) to increase engine speed. Move the lever to Slow (3) to decrease engine speed.

Choke Control

(988101, 102, 103, 104, 112, 115, 119)



Use the choke control to start a cold engine. Pull the control out to choke the engine. Push the control in when the engine gets warm.

Shift Lever

The shift lever sets the direction and speed of the unit.

R = reverse

N = neutral

1 = the slowest forward speed

5 = the fastest forward speed.

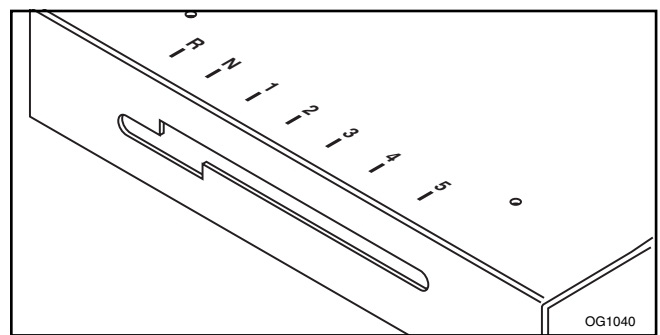

PTO Clutch (988100, 101, 102, 103, 104, 110, 112)

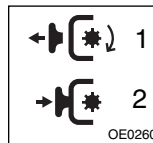

Pull the PTO (power take off) switch On (1) to engage the mower blades. Push the PTO switch Off (2) to disengage the mower blades.

PTO Clutch (988114, 115, 118, 119, 313)

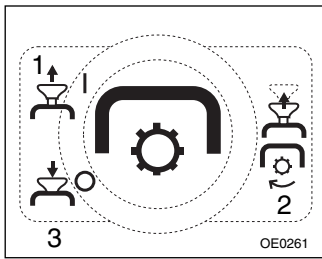

Pull the PTO (power take off) switch past On (1) to Reset (2) to engage the mower blades. Push the PTO switch Off (3) to disengage the mower blades.

NOTE: Pull PTO switch to Reset (2) to engage mower blades after operator presence control has been released.

Parking Brake (988114, 115, 118, 119, 313)

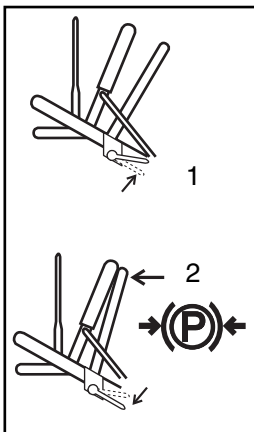

The pivot bar can hold the tractor in position when not in use.

To engage brake, loosen pivot bar (1).

Pull pivot bar back against the steering levers and lock in position (2).

Recoil Starter Handle

Pull the recoil starter handle to start the engine.

Hour Meter

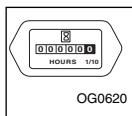

Electric Start: The hour meter measures the number of hours that the key is in the run position and operator presence control is engaged.

Recoil Start: The hour meter measures the number of hours the engine is running.

Oil Pressure Light (988104)



The red light near this symbol comes on when the engine is running and engine oil pressure is low. Check oil level and add if necessary. See Engine Manual.

FILL FUEL TANK



WARNING: Fuel is highly flammable and its vapors are explosive. Handle with care. Use an approved fuel container.

NO smoking, NO sparks, NO flames. ALWAYS allow engine to cool before servicing.

NEVER fill fuel tank when engine is running or hot from operation.

NEVER fill or drain fuel tank indoors.

Replace fuel cap securely and clean up spilled fuel.

Add fuel to the fuel tank as needed. See engine manual for type and grade of fuel.

To add fuel to the fuel tank:

1. Put the unit in an open area.
2. Stop the engine.
3. Allow engine to cool.
4. Clean the fuel cap and the area around the fuel cap to prevent dirt from entering the fuel tank.
5. Remove the cap from the fuel tank.
6. Fill the fuel tank. Be careful not to spill.
7. Install the cap on the fuel tank and tighten.
8. Clean up any spilled fuel before starting the engine.

TO STOP IN AN EMERGENCY

1. Release operator presence control(s).
2. Turn the ignition key Off.
3. Allow engine to stop completely.
4. Lock steering levers in neutral (988100, 101, 102, 103, 104, 110, 112).

STARTING AND SHUT OFF

Before Each Use

Check each item in *Each Use* in the Maintenance Schedule.

NOTE: On 988100, 101, 102, 103, 104, 110, 112 the engine will not start unless the shift lever is in neutral and the Power Take Off (PTO) is Off. On 988114, 115, 118, 119, 313 the engine will not start unless the Power Take Off (PTO) is off.

Recoil Start (988100, 101, 102, 103, 110, 112)

1. Lock the steering lever latches in neutral.
2. Put the shift lever in neutral.
3. Move PTO switch to Off.
4. Set throttle to the proper starting position. If the engine is cold, choke the engine.
5. Turn ignition switch to On.

6. Grasp recoil starter handle and pull rope out slowly until it pulls harder. This is the compression stroke.
7. Let the rope rewind slowly.
8. Pull rope with rapid continuous full arm stroke to start engine. Allow rope to rewind slowly.

IMPORTANT: DO NOT let starter handle snap against engine.

9. Repeat until engine starts. (If engine does not start, refer to Engine Manual.)
10. After engine starts, adjust choke as needed. Allow engine to warm and run smoothly before operating unit.

Recoil Start (988114, 115, 118, 119, 313)

1. Engage the parking brake.
2. Bring control levers to neutral.
3. Put the shift lever in neutral.
4. Move PTO switch to Off.
5. Set throttle to the proper starting position. If the engine is cold, choke the engine.
6. Turn ignition switch to On.
7. Grasp recoil starter handle and pull rope out slowly until it pulls harder. This is the compression stroke.
8. Let the rope rewind slowly.
9. Pull rope with rapid continuous full arm stroke to start engine. Allow rope to rewind slowly.

IMPORTANT: DO NOT let starter handle snap against engine.

10. Repeat until engine starts. (If engine does not start, refer to Engine Manual.)
11. After engine starts, adjust choke as needed. Allow engine to warm and run smoothly before operating unit.

Electric Start (988104)

To start the engine:

1. Lock the steering lever latches in neutral.
2. Put the shift lever in neutral.
3. Move PTO switch to Off.
4. If the engine is cold, choke the engine.
5. Move the throttle to Fast.
6. Put the ignition key in the switch and turn it to Start.

IMPORTANT: DO NOT operate starter motor more than 15 seconds per minute, as overheating and damage can occur. If engine will not start, refer to *Troubleshooting* or Engine Manual.

7. When the engine starts, release the key to Run position.

8. After engine starts, adjust choke as needed. Allow engine to warm and run smoothly before operating unit.

Shut Off

1. Lock steering levers in neutral (988100, 101, 102, 103, 104, 110, 112) .
Bring control levers to neutral (988114, 115, 118, 119, 313).
2. Move the throttle lever to Slow.
3. Put the shift lever in neutral.
4. Turn the ignition key Off.
5. Allow engine to stop completely.

TO OPERATE UNIT

Operate the unit only in the operator's position directly behind the handlebars.



WARNING: AVOID INJURY. When the engine is running and the speed control lever is engaged, holding only one steering lever in neutral causes the unit to circle sharply around one drive wheel.

988100, 101, 102, 103, 104, 110, 112

To shift unit:

1. Stop unit movement by pulling both steering levers all the way up.
2. You can move the shift lever one of two ways:
 - Continue to hold up both steering levers and use your knee to move the shift lever to the desired position.
 - Lock both steering levers. Move the shift lever to the desired position. Hold the steering levers up as you unlock them.
3. Release both steering levers slowly.

To operate:

1. Start the engine (See *Starting and Shut Off* on page 12).
2. Move the throttle lever to the Fast position.
3. Engage the operator presence control and move shift lever to desired direction and speed.
4. Hold steering levers in neutral and release steering latch levers.



WARNING: AVOID INJURY. When the engine is running and the shift lever is engaged, releasing only one steering latch causes the unit to circle around one drive wheel.

ALWAYS hold both steering levers in the neutral position when releasing the steering lever latches.

ALWAYS release levers slowly.

- To move straight forward; slowly release both steering levers to the full outward position.



- To stop unit in neutral, hold levers in the neutral position.



- To lock unit in neutral, engage both steering latches.



- To turn to the left, pull the left hand lever up.

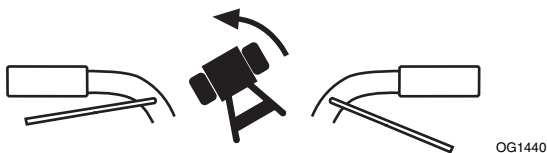

- To turn to the right, pull the right hand lever up.



To move in reverse:

- Place steering levers in neutral.
- Engage steering lever latches.
- Engage the operator presence control and move shift lever to Reverse.
- Hold steering levers in neutral and release latches.
- Release steering levers slowly.



WARNING: Uncontrolled reverse travel can result in serious injury.

Do not put shift lever into the reverse position unless you are prepared to operate in reverse.

To mow:

- Lock steering levers in neutral.
- Put the shift lever in neutral.
- Move the throttle lever to the fast position.
- Engage the operator presence control lever.
- Move the PTO switch to On to engage mower.

IMPORTANT: NEVER engage the PTO if the mower is plugged with grass or other material. This will damage the PTO belt.

- Move the shift lever to set a slow ground speed.
- Hold steering levers in neutral and release latches.
- Release steering levers slowly.

When you know how to operate the unit, select a speed appropriate to your mowing conditions.

To stop mowing:

- Lock the steering levers in neutral.
- Keep one hand on the operator presence control and move the shift lever to the neutral position.
- Move the throttle lever to 1/2 speed.
- Turn off PTO switch.

988114, 115, 118, 119, 313

To shift unit:

- Stop unit movement by bringing control levers to neutral.
- With control levers in neutral, use your knee or hand to move the shift lever to the desired position.
- Push both control levers forward slowly to move in selected direction.

To operate:

- Start the engine (See *Starting and Shut Off* on page 12).
- Move the throttle lever to the Fast position.
- Move shift lever to desired direction and speed.
- Engage operator presence control.



WARNING: AVOID INJURY. When the engine is running and the shift lever is engaged, using one steering control lever causes the unit to circle around one drive wheel.

ALWAYS hold both steering levers when operating unit and move levers slowly.

- To move straight forward, slowly push control levers forward.

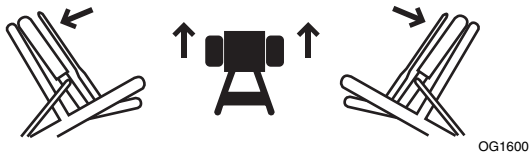

- To stop unit motion, allow control levers to return to neutral.

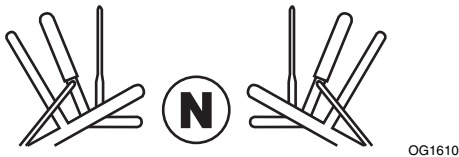

- To turn to the left, push the right hand control lever forward.

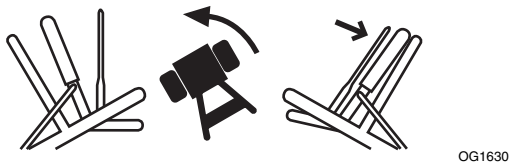

- To turn to the right, push the left hand control lever forward.

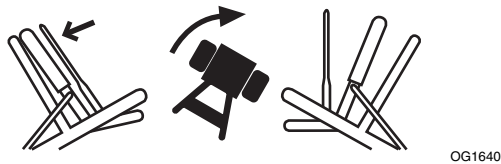

To move in reverse:

- Allow control levers to return to neutral.
- Move shift lever to Reverse.
- Pull up slowly on the lower control levers.

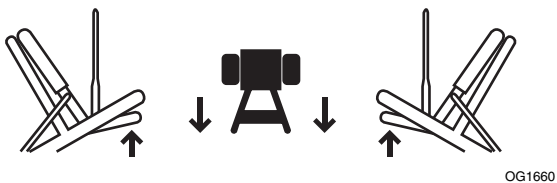

WARNING: Uncontrolled reverse travel can result in serious injury.
Do not put shift lever into the reverse position unless you are prepared to operate in reverse.

To mow:

- Move the shift lever to set a slow ground speed.
- Move the throttle lever to the fast position.
- Engage operator presence control(s).

NOTE: Operator presence control must remain engaged.

- Move the PTO switch to On to engage mower.

IMPORTANT: NEVER engage the PTO if the mower is plugged with grass or other material. This will damage the PTO belt.

- Push control levers forward slowly.

When you know how to operate the unit, select a speed appropriate to your mowing conditions.

To stop mowing:

- Allow control levers to return to neutral.
- Move the throttle lever to 1/2 speed.
- Turn off PTO switch.
- Move shift lever to the neutral position.

CUTTING HEIGHT ADJUSTMENT

Fixed Decks (988100, 101, 102, 110, 112, 114, 115, 118, 119, 313)

- Shut off the unit. See *Shut Off* on page 13 and "To stop mowing."
- Lift deck by handle until mower lock pins can be pulled out of holes.
- Turn latches slightly so they can't snap back into place.
- Set deck to desired cutting height (Figure 5).
- Place mower lock pins into desired hole.

IMPORTANT: Make sure lock pins are fully engaged.

- Repeat adjustment for other side of deck.

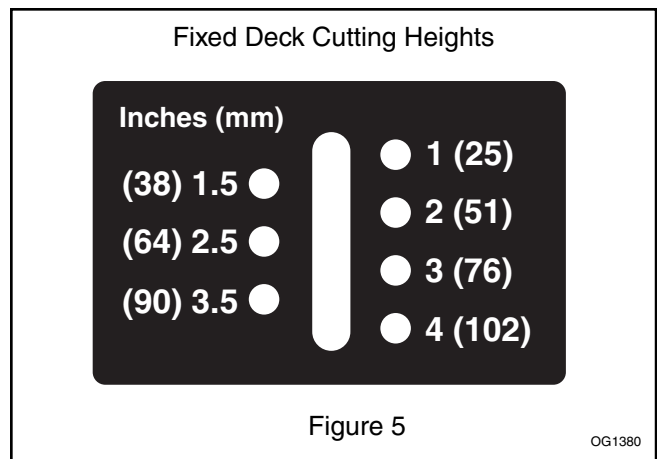

Floating Decks (988103, 104)

- Shut off the unit. See *Shut Off* on page 13 and "To stop mowing."
- Lift deck by handle until hair pins can be removed from height adjustment rods.
- Set deck to desired cutting height (Figure 6).
- Insert hair pins into appropriate holes on height adjusting rods.
- Repeat adjustment for other side of deck.

NOTE: It may be necessary to adjust cutting height in steps to keep deck from binding.

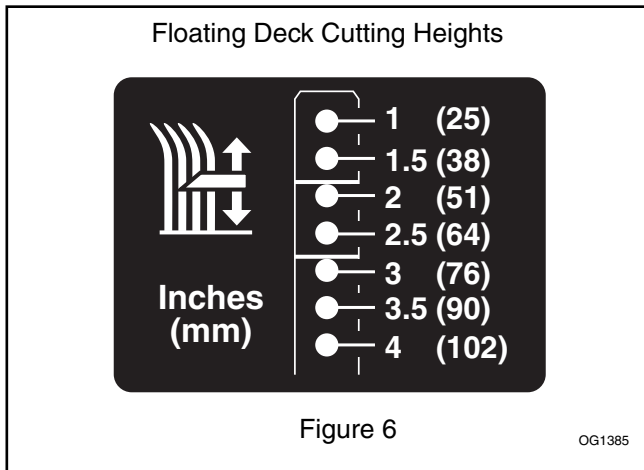

LAWN STRIPER ADJUSTMENT (44" and 48" decks; optional on 32" and 36" decks)

The striper drags behind the deck and shapes grass as you mow.

Adjust the striper to match cutting height.

Short grass (deck low): mount from bottom holes.

Tall grass (deck high): mount from top holes.

PARKING

988100, 101, 102, 103, 104, 110, 112

1. Shut off the unit. See *Shut Off* on page 13 and "To stop mowing."
2. Remove the key.
3. Lock both steering lever latches in neutral to engage the brakes.
4. Chock or block the wheels if parked on a slope.

988114, 115, 118, 119, 313

1. Shut off the unit. See *Shut Off* on page 13 and "To stop mowing."
2. Remove the key.
3. Lock pivot bar against control levers.
4. Chock or block the wheels if parked on a slope.

TO PUSH UNIT BY HAND

988100, 101, 102, 103, 104, 110, 112

To move the unit without the engine running:

1. Put the shift lever in neutral.
2. Hold steering levers in neutral and disengage latches. Release steering levers. The brake is disengaged when the steering levers are released.
3. Push unit to desired location.

IMPORTANT: Towing the unit will damage transmission.

988114, 115, 118, 119, 313

To move the unit without the engine running:

1. Put the shift lever in neutral.
2. Push the control levers all the way forward to release the brakes.
3. Push unit to desired location.

IMPORTANT: Towing the unit will damage the transmission.

TO TRANSPORT UNIT

ALWAYS shut off engine, remove key and drain fuel when transporting unit on a truck or trailer. Use extra care when loading or unloading unit.

Lock both steering lever latches in neutral to engage the brakes, or lock pivot bar against control levers.

Secure unit chassis to transport vehicle. NEVER secure from rods or linkages that could be damaged.

DO NOT transport machine while engine is running.

MAINTENANCE



WARNING: AVOID INJURY. Read and understand the entire *Safety* section before proceeding.

MAINTENANCE SCHEDULE

	Each Use	25	50	100
Check Safety Interlock System	●			
Check Air Cleaner	●			
Check Engine Oil	●			
Check Engine Cooling	●			
Check Fasteners	●			
Check Tire Pressure	●			
Check Battery and Battery Fluid		●		
Check All Belts		●		
Mower Blades		●		
Clean Air Cleaner Foam Element		●		
General Lubrication			●	
Change Engine Oil				*●
Check Fuel Filter				●
Check Spark Plug				●
Check Muffler				●
Clean Air Cleaner Paper Element				●

* Change oil after first 8 hours of operation and every 100 hours thereafter.

CHECK SAFETY INTERLOCK SYSTEM

Test the safety interlock system at each operation. If the system does not function properly, do not operate the unit until repairs are made.

988100, 101, 102, 103, 104, 110, 112

Engine must not start unless PTO is disengaged and the shift lever is in neutral. To test:

1. With engine off, engage PTO.
2. Turn electric start model ignition switch to Start. Engine must not crank.

Turn recoil start model ignition switch to On. Pull recoil start handle. Engine must not start.

3. Disengage PTO.

The engine **MUST** stop whenever the operator removes both hands from controls while the PTO or transmission is engaged. To test:

1. Start engine and engage PTO.
2. Release operator presence control lever(s). Engine must stop.
3. Disengage PTO.
4. Restart engine.
5. Place shift lever in Forward.
6. Release operator presence control lever. Engine must stop.

988114, 115, 118, 119, 313

Blades must not rotate unless the operator presence control levers and PTO are engaged. To Test:

1. With engine on, release operator presence controls and engage PTO.
2. Blades must not rotate.
3. Disengage PTO.

The blades **MUST** stop whenever the operator removes both hands from controls while the PTO is engaged. To test:

1. Start engine and engage PTO.
2. Release operator presence control lever(s). Blades must stop.

NOTE: All motion must stop whenever operator releases control levers.

CHECK AIR CLEANER

Check the air cleaner element before each use. See engine manual for detailed instructions.

CHECK ENGINE OIL

Check the engine oil level before each use. Never operate the engine when the oil level is low. See engine manual for detailed instructions.

CHECK ENGINE COOLING

Check the engine air cooling system before each use. See engine manual for detailed instructions.

CHECK FASTENERS

Check all nuts, bolts, and other fasteners before each use. Replace missing or damaged fasteners.

CHECK TIRE PRESSURE

Check tires for proper inflation, excessive wear or damage before each use. The correct air pressure is 8 to 16 psi (55 to 110 kPa).

CHECK BATTERY (988104)



WARNING: AVOID INJURY. Read and understand the entire *Safety* section before proceeding.



WARNING: Battery posts, terminals and related accessories contain lead and lead compounds, chemicals known to the State of California to cause cancer and reproductive harm. Wash hands after handling.

Terminals

Inspect battery and terminals every 25 hours.

To clean terminals:

1. Remove battery cover.
2. Remove battery cables from terminals.
3. Clean or service battery away from unit. Remove corrosion from battery terminals and cable connections with wire brush, then wash with a weak baking soda solution.
4. Apply a thin coat of dielectric grease or petroleum jelly to terminals and cable ends to retard corrosion.
5. Replace battery and secure with battery cover.

CHECK ALL BELTS

Check all belts for wear or damage every 25 hours. If belts slip, check for damaged belts or tensioner.

MOWER BLADES

Check mower blades for wear every 25 hours of operation. Ensure blade hardware is tightened to 115-125 lbf-ft (156-169.5 N•m) of torque.

CLEAN AIR CLEANER FOAM ELEMENT

See engine manual for detailed instructions.

GENERAL LUBRICATION

Apply a small amount of oil to the pivot points as required for smooth operation (Figure 7).

Apply high quality lithium based grease to all lube fittings every 50 hours of operation.

NOTE: The mower spindle assembly is maintenance free.

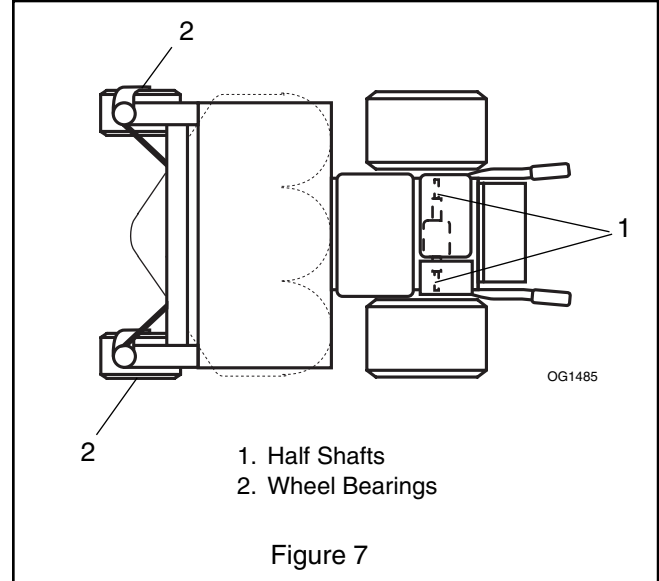

CHANGE ENGINE OIL

Open the petcock to drain oil through oil drain hole on left side of engine. See engine manual for additional instructions.

CHECK FUEL FILTER

See engine manual for detailed instructions.

CHECK SPARK PLUG

See engine manual for detailed instructions.

CHECK MUFFLER

Check muffler for damage or wear. Replace if necessary.

CLEAN AIR CLEANER PAPER ELEMENT

See engine manual for detailed instructions.

SERVICE AND ADJUSTMENTS



WARNING: AVOID INJURY. Read and understand the entire *Safety* section before proceeding.

ADJUSTING THE UNIT TO TRACK STRAIGHT

Check Forward Tracking

1. Start engine and run unit at full throttle.

2. Shift into a forward gear and slowly release both steering levers to the full outward position (988100, 101, 102, 103, 104, 110, 112).
Shift into a forward gear and slowly push both control levers against the pivot bar (988114, 115, 118, 119, 313).
3. Note which direction, if any, the unit pulls.
4. Stop unit and engine.

5. Adjust tracking if needed.

Try each of the following steps until the unit tracks straight. It may not be necessary to perform all the steps.

If unit turns to the right:

1. Reduce the air pressure in the left tire.
2. Increase the air pressure in the right tire.
3. Check for brake binding on right wheel and adjust as needed.

If unit turns to the left:

1. Reduce the air pressure in the right tire.
2. Increase the air pressure in the left tire.
3. Check for brake binding on left wheel and adjust as needed.

Check Reverse Tracking

1. Adjust forward tracking (See *Check Forward Tracking* on page 18).
2. Move shift lever into Reverse and slowly pull up on the lower control levers.
3. Note which direction, if any, the unit pulls.
4. Stop unit and engine.
5. Adjust tracking if needed.

If unit turns to the right:

1. Reduce the air pressure in the left tire.
2. Increase the air pressure in the right tire.
3. Check reverse tracking and adjust as needed.

If unit turns to the left:

1. Reduce the air pressure in the right tire.
2. Increase the air pressure in the left tire.
3. Check reverse tracking and adjust as needed.

ADJUST STEERING LEVERS

For each lever:

1. Turn off the engine, remove the key and allow unit to cool.
2. Release steering or control levers (Figure 8).
3. Shift transmission into neutral. Operate steering or control lever several times. Do not move unit.
4. Remove hair pin and clevis pin from the clevis on the steering control rod.
5. 988100, 101, 102, 103, 104, 110, 112: Adjust the clevis on the steering control rod until the gap between the ends of the steering lever and handlebar grip is 2-1/2 to 3 in. (6.35-7.6 cm).
988114, 115, 118, 119, 313: Set pivot bar all the way forward, and then adjust the clevis on the steering control rod until the gap between the ends of the control lever and pivot bar is 2-1/2 to 3 in. (6.35 - 7.6 cm).

6. Reinstall the clevis pin and hair pin.
7. Repeat for other steering lever.

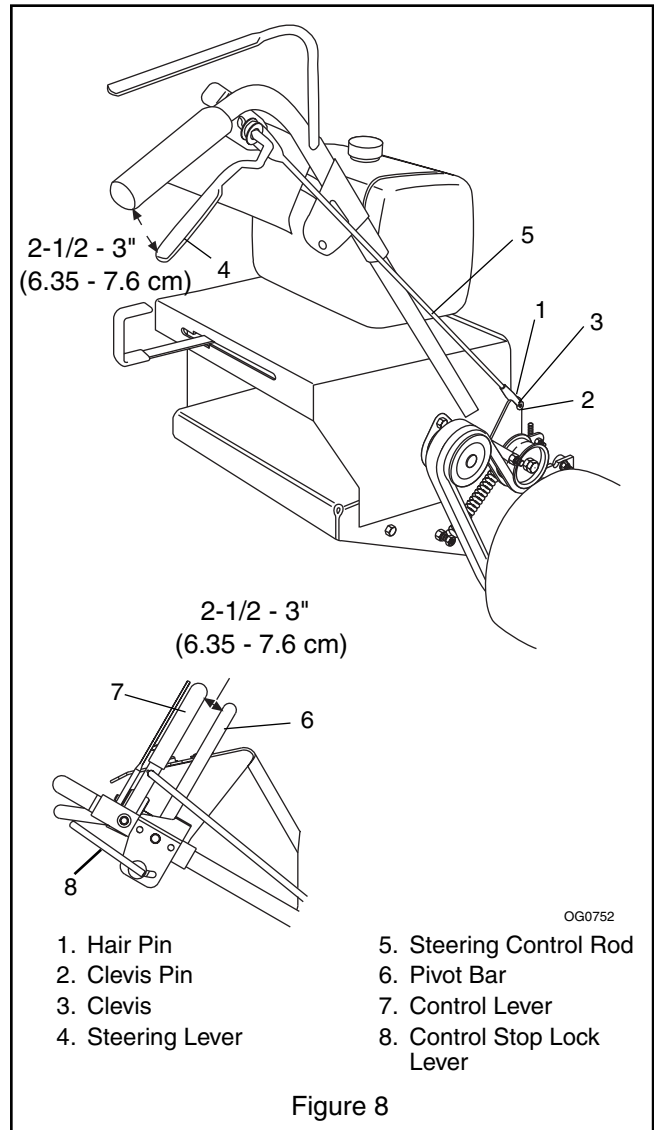
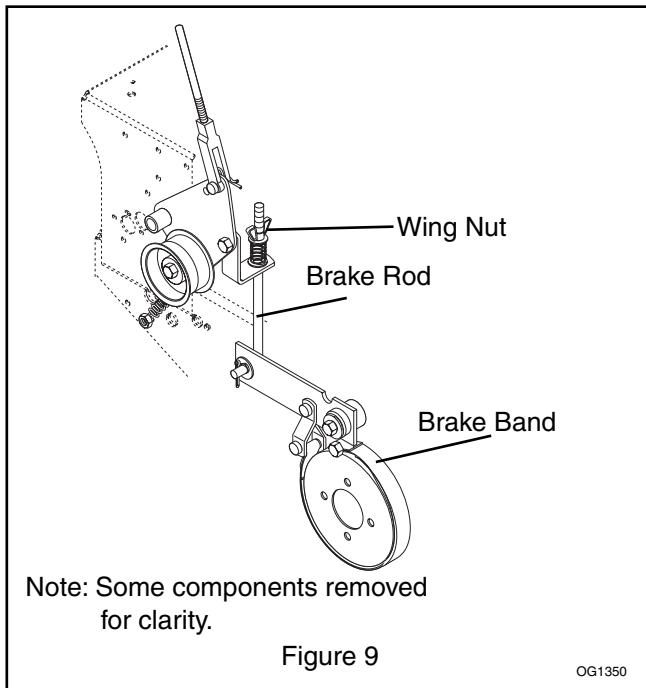

Figure 8

ADJUST BRAKES

NOTE: The traction belt must disengage as the brake starts to engage.

1. Turn off the engine, remove the key and allow unit to cool.
2. If brakes do not disengage fully when traction belt is engaged, the brakes are too tight. Loosen the wing nut (Figure 9).
3. If brakes do not engage fully when traction belt is disengaged, the brakes are too loose. Tighten the wing nut.
4. Start engine and test in low gear for proper brake engagement.



REPLACE TRACTION BELTS

1. Turn off the engine, remove the key and allow unit to cool.
2. Release the steering levers (988100, 101, 102, 103, 104, 110, 112).
3. Raise the rear of the unit so that the drive wheels are off the ground.
4. Remove traction belt guard.
5. Remove clutch idler pulley spring (Figure 10).



WARNING: AVOID INJURY. An extension spring, when extended, stores energy and can be dangerous. Always use tools specifically designed for installing or removing an extension spring. Always compress or extend springs slowly.

6. Remove hair pin and clevis pin holding steering control rod to wheel clutch arm weldment.

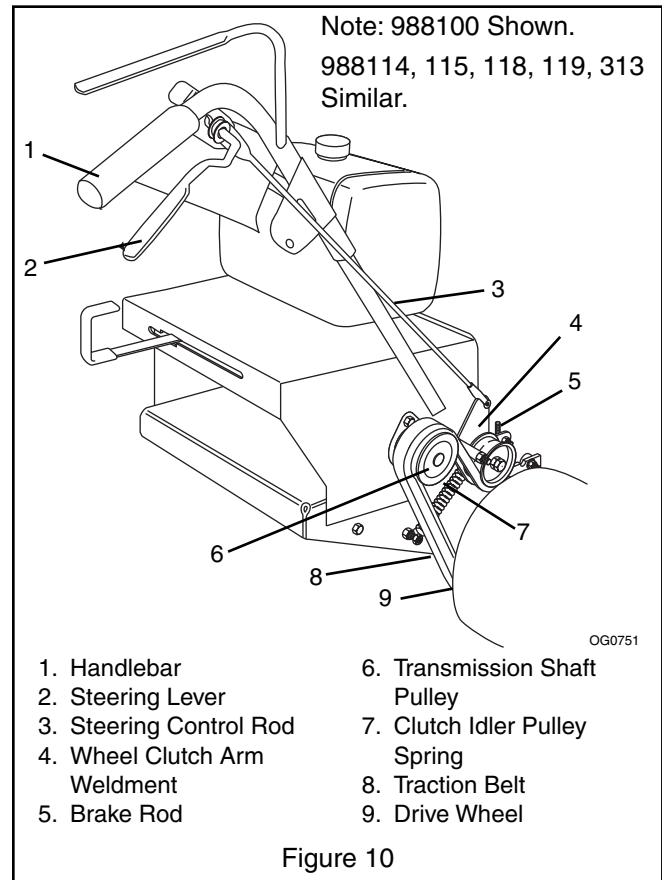

- | | |
|------------------------------|-------------------------------|
| 1. Handlebar | 6. Transmission Shaft Pulley |
| 2. Steering Lever | 7. Clutch Idler Pulley Spring |
| 3. Steering Control Rod | 8. Traction Belt |
| 4. Wheel Clutch Arm Weldment | 9. Drive Wheel |
| 5. Brake Rod | |

7. While slowly turning the drive wheel, work the traction belt off the transmission shaft pulley and drive wheel.
8. Install new traction belt.
9. Connect steering control rod to wheel clutch arm weldment with clevis pin and hair pin.
10. Replace clutch idler pulley spring.
11. Replace traction belt guard.
12. Lower the unit.
13. Check steering lever adjustment. See *Adjust Steering Levers* on page 19.

ADJUST SHIFT LEVER LINKAGE

The transmission shift lever is attached to the transmission shift arm with two 5/16-18 bolts (Figure 11).

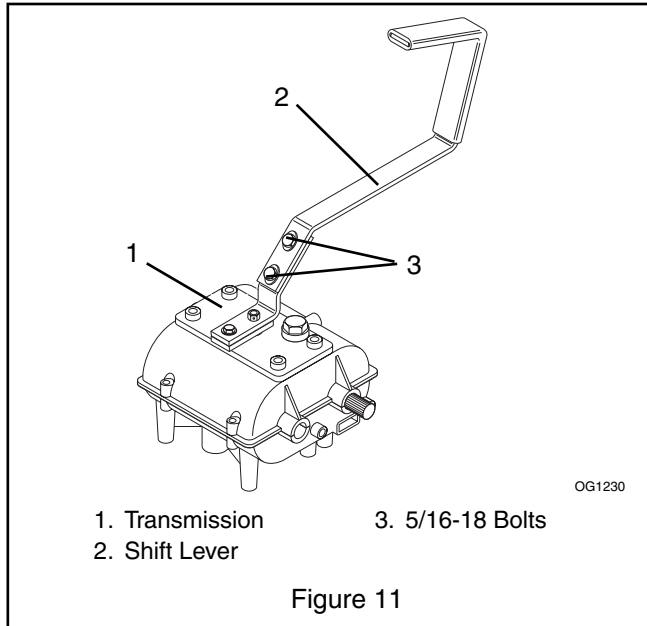

To adjust:

1. Stop the engine. Remove ignition key. Put PTO lever in the "OFF" position. Put the shift lever in neutral.
2. Loosen two 5/16-18 bolts in shift lever.
3. Center shift lever vertically in forward slot, just touching the reverse stop (Figure 12).

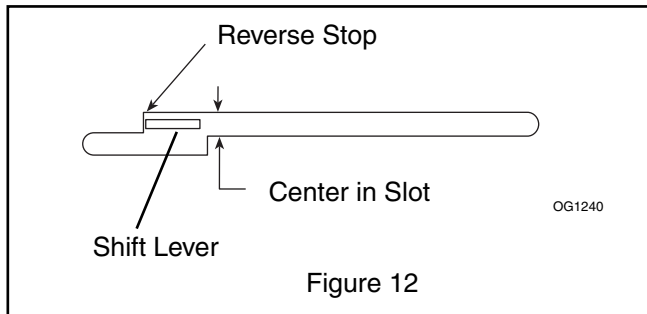

4. Tighten bolts securely.

NOTE: You should *not* be able to shift into reverse without pushing down on the shift lever.

REPLACE TRANSMISSION BELT

1. Stop the engine. Remove ignition key. Put PTO lever in the "OFF" position. Put the shift lever in neutral.
2. Remove mower drive belt from mower clutch sheave. Refer to *Belt Replacement* for your deck.
3. Remove transmission belt idler spring (Figure 13).



WARNING: AVOID INJURY. An extension spring, when extended, stores energy and can be dangerous. Always use tools specifically designed for installing or removing an extension spring. Always compress or extend springs slowly.

4. Loosen one and remove one front engine bolt. Save the hardware.
5. Turn the clutch bracket away from the clutch.
6. Remove old transmission belt from mower clutch sheave and transmission sheave.
7. Install new transmission belt in the top groove of the clutch hub and on the transmission sheave.
8. Install transmission belt idler spring to tension belt.
9. Reposition clutch bracket, replace engine bolt, and torque both engine bolts to 17 lbf-ft (23 N•m).

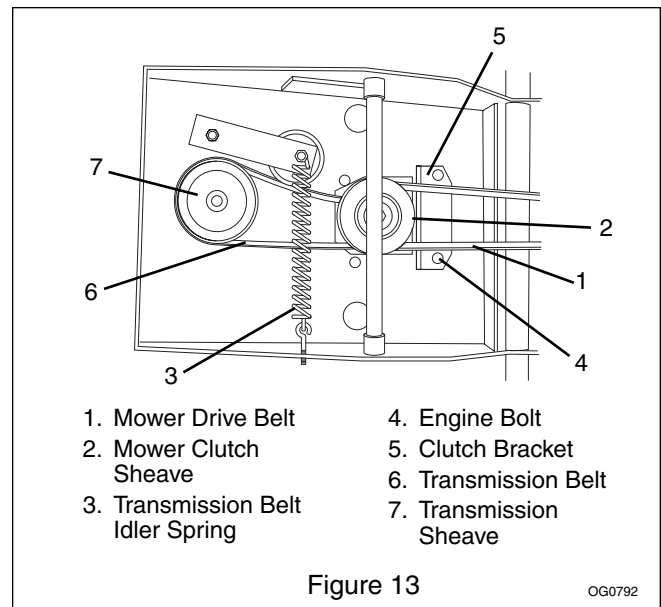

10. Reinstall mower drive belt on mower clutch sheave.

CLUTCH ADJUSTMENT

If clutch fails to engage or disengage properly or begins to make abnormal noise, check the air gap adjustment at the three inspection slots.

To check:

1. Stop engine, remove key and wait for all hot parts to cool.
2. Measure the air gap between the armature and the rotor.

Minimum: A .005" feeler gauge should slide between armature and rotor with slight contact.

Maximum: A .023" feeler gauge should slide between armature and rotor with slight contact.

3. Repeat for each inspection slot.

To adjust:

1. If necessary, loosen gap adjustment nuts until a .005" feeler gauge fits between armature and rotor.
2. Slide a .012" feeler gauge between armature and rotor.
3. Tighten gap adjustment nut until there is slight contact on feeler gauge.
4. Repeat steps 1 – 3 at each inspection slot.

NOTE: Adjust air gap as evenly as possible.

5. Start unit, engage and disengage PTO.
6. Shut off unit.
7. Recheck air gap and adjust if needed.

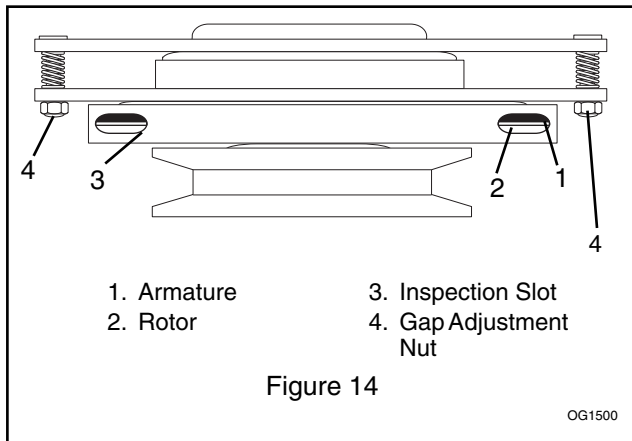

BATTERY (988104)

Unit comes equipped with a maintenance-free battery that requires no regular maintenance except cleaning the terminals. See *Check Battery (988104)* on page 18.



WARNING: AVOID INJURY. Read and understand the entire *Safety* section before proceeding.

Charge Battery



WARNING: FROZEN BATTERIES CAN EXPLODE and result in death or serious injury.

DO NOT charge a frozen battery. Let the battery thaw before charging.

Battery Electrolyte First Aid

- **External Contact:** Flush with water.
- **Eyes:** Flush with water for at least 15 minutes and get medical attention immediately!
- **Internal Contact:** Drink large quantities of water. Follow with Milk of Magnesia, beaten egg or vegetable oil. Get medical attention immediately! DO NOT induce vomiting!

IMPORTANT: DO NOT fast charge. Charging at a higher rate will damage or destroy battery.

IMPORTANT: ONLY use an automatic charger designed for use with your battery. ALWAYS follow information provided on battery and battery charger. Contact battery and charger manufacturers for detailed instructions.

1. Remove battery cover.
2. Disconnect negative (-) cable first, then positive (+) cable (Figure 15).
3. Remove battery.
4. Place battery on bench or other well-ventilated area.
5. Connect positive (+) lead of charger to positive (+) terminal, and negative (-) lead to negative (-) terminal.
6. Charge battery according to charger and battery manufacturers' instructions.
7. Reinstall battery on unit and connect positive (+) cable first, then negative (-) cable.

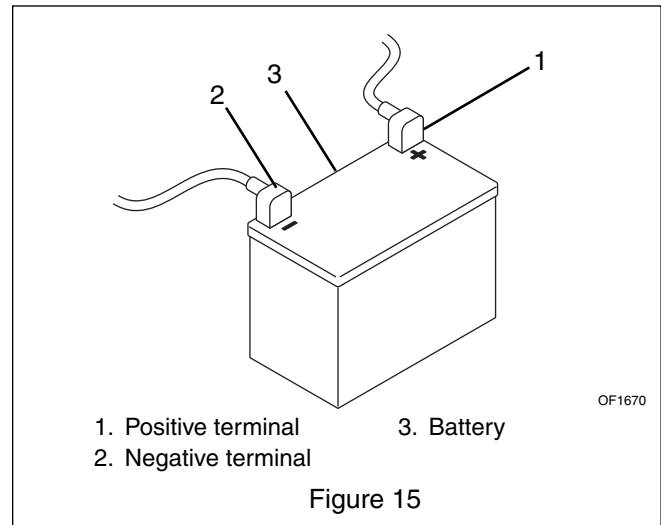

It may be possible to recharge the battery by jump starting the unit and allowing the engine to run.

Jump Start

The unit used for jump starting should have a 12-volt battery with at least 500 cold cranking amperes, and a negatively grounded system.

1. Ensure battery is not frozen. If the fluid is frozen, remove battery from unit and allow it to thaw before charging.
2. Connect the positive (+) jumper cable to the positive terminal of the discharged battery.
3. Connect the other end of the same jumper cable to the positive (+) terminal of the booster battery.
4. Connect one end of the second jumper cable to the negative (-) terminal of the booster battery.

5. Make the final jumper cable connection to the engine block or the furthest ground point away from the discharged battery.



WARNING: Make sure cables are clear of any moving engine parts before starting engine.

6. Start engine (See *Starting and Shut Off* on page 12). If engine will not start after several tries, unit or battery may need service.
7. After engine starts, leave cables connected for one to two minutes.
8. Disconnect cables in reverse order.
9. Operate unit normally to charge battery.

32" AND 36" BELT REPLACEMENT

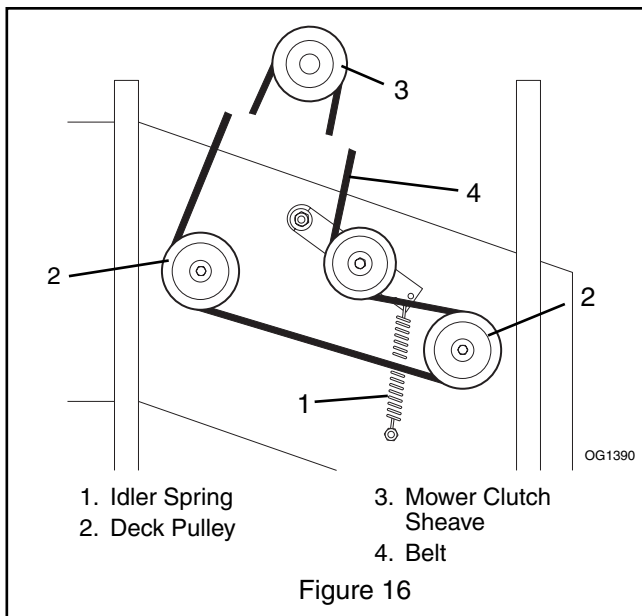

1. Stop engine, remove key and wait for all hot parts to cool.
2. Set deck to the fourth cutting height.
3. Remove deck cover.
4. Remove deck idler spring.
5. Remove belt from deck pulleys and mower clutch sheave.
6. Install new belt.
7. Replace idler spring.
8. Replace deck cover and secure.

NOTE: Make sure the wing knobs do not interfere with cutting height adjustments.

44" AND 48" BELT REPLACEMENT

Mower Drive Belt

1. Stop engine, remove key and wait for all hot parts to cool.
2. Set deck to the fourth cutting height.
3. Remove deck cover.
4. Remove mower drive belt idler spring (Figure 17).
5. Remove mower drive belt from deck sheaves and mower clutch sheave.
6. Install new mower drive belt on deck sheaves and mower clutch sheave.
7. Replace mower drive belt idler spring to tension belt.
8. Replace deck cover and secure.

NOTE: Make sure wing knobs do not interfere with cutting height adjustments.

Deck Belt

NOTE: Mower drive belt must be removed before removing the deck belt.

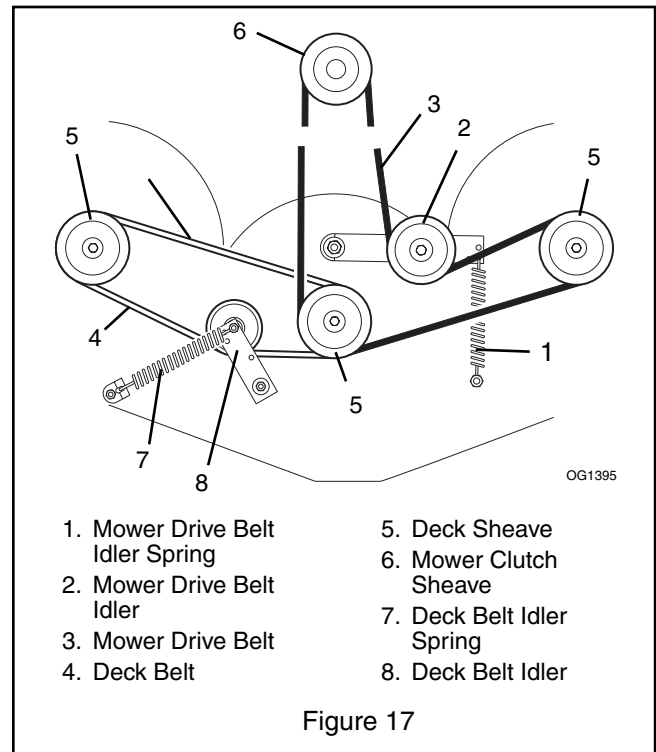

1. Stop engine, remove key and wait for all hot parts to cool.
2. Remove the deck belt idler spring from the spring anchor.
3. Remove deck belt from deck sheaves.
4. Install new deck belt.
5. Replace deck idler spring to tension belt.
6. Replace mower drive belt.
7. Replace deck cover.

MOWER BLADES

NOTE: If mower is used under sandy soil conditions, replace blades when air lifts become eroded through at ends (Figure 18).

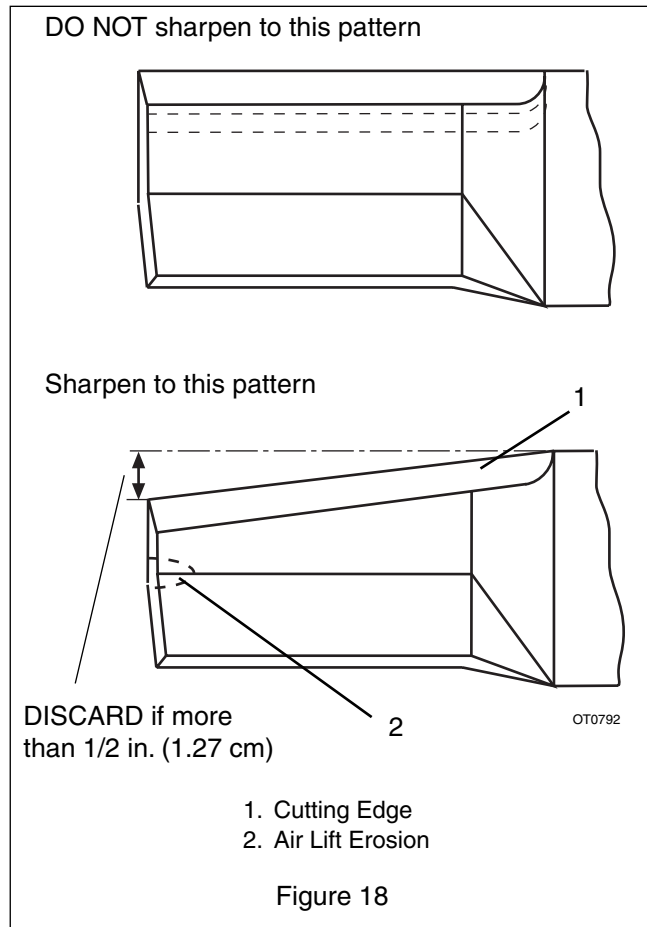

Remove



CAUTION: Use sturdy gloves or padding to protect hands when working with mower blades.

1. Turn the engine off. Remove the ignition key. Remove the ignition wire from the spark plugs.
2. Remove the bolts, lock washer, flat washers, and blades from the spindle shafts.

Replace

1. Put the blades, flat washers, lock washers, and the bolts back on the spindle shafts.
2. Tighten the bolts to a torque of 115-125 lbf-ft (156-169.5 N•m).
3. Replace ignition wire on spark plugs.

Sharpen the Mower Blades

Figure 18.



CAUTION: DO NOT sharpen mower blades while on unit. An unbalanced mower blade will cause excessive vibration and eventual damage to unit. Check mower blade balance before reinstalling blades.

NEVER weld or straighten bent blades.

1. Remove mower blade from unit.

Discard mower blade if:

- More than 1/2 in. (1.27 cm) of metal is removed.
- Air lifts become eroded.
- Blade is bent or broken.

2. Sharpen mower blade by removing an equal amount of material from each end of mower blade. DO NOT change angle of cutting edge or round the corner of the mower blade.
3. Check mower blade balance.

Slide mower blade on an unthreaded bolt. A balanced blade should remain in a horizontal position. If either end of mower blade moves downward, sharpen the heavy end until blade is balanced.

4. Install mower blade(s) on unit (See *Mower Blades* on page 24).

STORAGE



WARNING: AVOID INJURY. Read and understand the entire *Safety* section before proceeding.

Storage – Two Months or More

Check each item in the *Maintenance Schedule* on page 17, but do not add gasoline.

Clean the unit. Touch up all scratched painted surfaces.

IMPORTANT: Never spray unit with high-pressure water or store unit outdoors. Store unit in a cool, dry, protected location.

NOTE: Clean unit thoroughly with mild soap and low pressure water and lubricate (see Maintenance). Touch up all scratched painted surfaces. Do not allow gasoline or oil to remain on any decals.

Engine

Refer to the engine manual to prepare the engine for storage.

Battery

Remove battery and store in a cool, dry place.

TROUBLESHOOTING

PROBLEM	PROBABLE CAUSE	CORRECTION
Engine will not start	<ol style="list-style-type: none"> 1. Safety Interlock System is preventing start. 2. Fuel tank is empty or fuel is contaminated. 3. Air cleaner is clogged or damaged. 4. Safety Interlock System out of adjustment or defective. 5. Dirty or damaged spark plug. 	<ol style="list-style-type: none"> 1. The engine will not start unless the shift lever is in neutral, the key is in the On position and the Power Take Off (PTO) is Off (988100, 101, 102, 103, 104, 110, 112). The engine will not start unless the key is in the On position, and the Power Take Off (PTO) is Off (988114, 115, 118, 119, 313). 2. Add fuel. If necessary, replace the fuel with clean, fresh fuel. 3. Clean or replace the filter element. See engine manual. 4. See your Dealer for repairs. 5. See Engine Manual.
Unit will not move or mow when the engine is running	<ol style="list-style-type: none"> 1. Transmission belt or mower belt is broken, worn, or off the pulleys. 	<ol style="list-style-type: none"> 1. Check belts for wear, damage and correct position on pulleys. Replace belts if worn or damaged. See <i>Replace Transmission Belt</i> on page 21.
Changes in the sound or vibrations of the unit	<ol style="list-style-type: none"> 1. Loose or missing fasteners. 2. Mower blade problem. 3. Worn or damaged clutch. 	<ol style="list-style-type: none"> 1. Check all the fasteners. Replace if necessary. 2. Check blades for wear or damage. See <i>Mower Blades</i> on page 24. 3. See your Dealer for repairs.

PROBLEM	PROBABLE CAUSE	CORRECTION
Unit pulls sharply to the left or right when the speed control levers are quickly moved all the way forward Unit does not straighten immediately when the steering levers are released	1. Steering levers out of adjustment.	1. See <i>Adjust Steering Levers</i> on page 19.
Unit loses power	1. Binding in the steering or brake linkage. 2. Steering levers out of adjustment. 3. Worn or damaged traction belts. 4. Transmission shaft pulley worn.	1. Check linkage for debris or damage. Repair if necessary. See <i>Adjust Brakes</i> on page 19 or your Dealer for repairs. 2. See <i>Adjust Steering Levers</i> on page 19. 3. Check belts for wear or damage. Replace if necessary. See <i>Replace Traction Belts</i> on page 20. 4. If pulley shows excessive wear, replace it. See your Dealer for repairs.

ACCESSORIES	
Part No.	Description
78804700	32" Mulching Kit
78803300	36" Mulching Kit
78805300	44" Mulching Kit
78803400	48" Mulching Kit
78803700	36" Bahia/Tall Grass Baffle Kit
78805400	44" Bahia/Tall Grass Baffle Kit
78803800	48" Bahia/Tall Grass Baffle Kit
78804500	32" Lawn Striping Kit
78803600	36" Lawn Striping Kit
78804800	32" Double Blade Kit
78804000	36" Double Blade Kit
78804100	44" and 48" Double Blade Kit
78804200	Hour Meter Kit (988100, 101, 102, 103, 110)
78804300	Grass Catcher
78804400	Leaf Collector**
78805000	Single Wheel Sulky**
78805100	Two Wheel Sulky**

** NOT approved for 52-inch models. DO NOT use on 52-inch models due to hillside parking limits.

SERVICE PARTS		
Part No.	Qty	Description
21538000	1	Paper Element (13 HP, 15 HP)
21538100	1	Foam Precleaner (13 HP, 15 HP)
21538200	1	Paper Element (17 HP)
21538300	1	Foam Precleaner (17 HP)
21538400	1	Fuel Filter
21535800	1	Oil Filter
21533600	2	Spark Plug
04919100	1	Mower Blade - 16.25" (988102, 103, 104, 110, 112, 113, 115, 118, 119)
04916400	1	Mower Blade - 18.00" (988100, 101, 114)
04936000	1	Mower Blade - 16.25" (988313)
07240000	1	Mower Drive Belt - 32" Deck
07240100	1	Mower Drive Belt - 36" Deck
07240300	1	Mower Drive Belt - 44" Deck
07240200	1	Mower Drive Belt - 48" Deck
07202900	1	Mower Deck Belt - 44" and 48" Deck
07243100	1	Transmission Belt
07239600	2	Traction Drive Belt

SPECIFICATIONS

Model Number	988100	988101	988102	988103	988104	988110
Description	GR1336FX	GR1536FX	GR1548FX	GR1548FL	GE1748FL	GR1332FX
Length – in (cm)	79.75 (202.5)		73.5 (186.7)	77 (195.6)		79.75 (202.5)
Height – in (cm)	42 (106.7)					
Width – in (cm)	38.12 (96.8)		50.58 (128.47)			35.3 (89.7)
Actual Weight – lbs (kg)	511 (232.3)		560 (254.5)		627 (285)	500 (226.8)
Battery	N/A				12V 255 CCA	N/A
Brakes	6" Band					
Turning Radius – in. (cm)	0					
Tire Size	16x6.5, 4-ply Rating					
Engine – Manufacturer	Kawasaki FH381V-BS04	Kawasaki FH430V-BS06			Kawasaki FH500V-BS35	Kawasaki FH381V-BS04
Cycle	4					
Horsepower – HP (Kw) @ 3600 RPM	13 (9.7)	15 (11.2)			17 (12.7)	13 (9.7)
Starting System	Recoil				Electric	Recoil
Fuel Tank Capacity Gal. (L)	6.6 (25)					
Fuel	See Engine Manual					
Governed R.P.M. (max.)	3500 ± 50					
Crank Case Cap.	See Engine Manual					
Air Cleaner	Paper Element, Foam Precleaner					
Transmission	Peerless 5 Speed + Reverse					
Speed– Forward Max. – mph (km/hr)	2.6 – 6.7 (4.3 – 11.2)					
Reverse Max. – mph (km/hr)	Reverse Assist					
Tire Pressure – psi (kPa)	8-16 (55-110)					
Deck						
Cutting Width in. (cm)	35.25 (89.5)		47.25 (120)			31.75 (80.6)
Cutting Height in. (cm)	1–4 (2.54–10)					
Deck Construction	7-gauge steel with 7-gauge spindle reinforcement					
Discharge	Right Side					
CE Sound and Vibration						
Oper. Ear Sound Pressure (L _{pa}) in dB _A	N/A					
Vibration Measure (m/s ²) @ Operator Hands X	N/A					
Y	N/A					
Z	N/A					

SPECIFICATIONS

Model Number	988112	988114	988115	988118	988119	988313
Description	GR1544FX	GR1336FXP	GR1548FXP	GR1332FXP	GR1544FXP	GR1332FXPCE
Length – in (cm)	75.5 (191.8)	80.25 (203.8)	77.5 (196.9)	80.25 (203.8)	76.0 (193.0)	80.25 (203.8)
Height – in (cm)	42 (106.7)	43.5 (110.5)				
Width – in (cm)	47.0 (119.38)	38.2 (97.0)	50.58 (128.47)	35.3 (89.7)	47.0 (119.38)	35.3 (89.7)
Actual Weight – lbs (kg)	560 (254.5)	530 (240.9)	579 (263.2)	519 (235.4)	579 (263.2)	519 (235.4)
Battery	N/A					
Brakes	6" Band					
Turning Radius – in. (cm)	0					
Tire Size	16x6.5, 4-ply Rating					
Engine – Manufacturer	Kawasaki FH430V-BS06	Kawasaki FH381V-BS04	Kawasaki FH430V-BS06	Kawasaki FH381V-BS04	Kawasaki FH430V-BS06	Kawasaki FH381V-BS04
Cycle	4					
Horsepower – HP (Kw) @ 3600 RPM	15 (11.2)	13 (9.7)	15 (11.2)	13 (9.7)	15 (11.2)	13 (9.7)
Starting System	Recoil					
Fuel Tank Capacity - gal (L)	6.6 (25)					
Fuel	See Engine Manual					
Governed R.P.M. (max.)	3500 ± 50					2900 ± 50
Crank Case Cap.	See Engine Manual					
Air Cleaner	Paper Element, Foam Precleaner					
Transmission	Peerless 5 Speed + Reverse					
Speed– Forward Max. – mph (km/hr)	2.6 – 6.7 (4.3 – 11.2)					2.1 – 6.3 (3.5 – 10.5)
Reverse Max. – mph (km/hr)	Reverse Assist					
Tire Pressure - psi (kPa)	8-16 (55-110)					
Deck						
Cutting Width in. (cm)	44.0 (111.8)	35.25 (89.5)	47.25 (120)	31.75 (80.6)	44.0 (111.8)	31.75 (80.6)
Cutting Height in. (cm)	1–4 (2.54–10)					
Deck Construction	7-gauge steel with 7-gauge spindle reinforcement					
Discharge	Right Side					
CE Sound and Vibration						
Oper. Ear Sound Pressure (L_{pa}) in dB_A	N/A					87
Vibration Measure (m/s^2) @ Operator Hands X	N/A					<2.5
Y	N/A					<2.5
Z	N/A					<2.5



Gravely Division of Ariens Company

655 West Ryan Street
P.O. Box 157
Brillion, WI 54110-0157
920-756-2141
Fax 920-756-2407
www.gravely.com

2-Year Limited Warranty

Gravely Division of Ariens Company (Gravely) hereby warrants to the original consumer purchaser that all Gravely Two-Wheel, Professional G, Pro, and ProMaster products will be free from defects in material and workmanship for a period of two (2) years from the date of purchase or 1000 hours, whichever comes first.

Protection Plan

Gravely will repair or replace any part found upon examination by Gravely to be defective. Such repair or replacement will be free of charge to the purchaser (labor and parts), except as noted below.

This warranty is subject to the following exceptions, conditions, and limitations:

Usage Requirement

The duration of this warranty shall be ninety days or 1000 hours, whichever comes first, if the product is rented or leased.

Purchaser's Responsibilities

- The purchaser must perform maintenance and minor adjustments per the operator's manual.
- The purchaser must notify Gravely or an authorized Gravely service representative of the need for warranty service.
- The purchaser must transport the product to and from the place of warranty repair.

Product Registration

- Returning the product registration card to Gravely will enable the company to contact the registrant with repair or replacement part information.

Service Parts and Accessories

- Service parts and accessories not purchased with the product covered by this warranty are warranted to be free of defects for a period of ninety (90) days following the date of purchase, and will be replaced free of charge (except for labor).

Service

- Warranty service must be done by an authorized Gravely dealer. To find an authorized Gravely service representative, contact Gravely at the website, number or address above.

Battery Warranty Prorated

- One to three months - Free replacement
- Four to twelve months - Prorated over 12 months

Exclusions (No Warranty)

- Normal maintenance, services, and normal replacement items, such as spark plugs, oil, oil filters, air filters, mufflers, belts, tires, shoes, runners, scraper blades, shear bolts, mower blades, mower vanes, headlights, light bulbs, knives, etc. are not covered by this warranty.
- Any equipment which has been altered, misused, misassembled, improperly adjusted, neglected, or damaged by accident is not covered by this warranty.
- Service completed by someone other than an authorized Gravely dealer is not covered by this warranty.
- Any attachment not approved by Gravely nor any parts that are not genuine Gravely service parts are not covered by this warranty.
- Engines and engine accessories are covered only by the warranty made by the engine manufacturer, and are not covered by this warranty.
- If the product is equipped with a Hydro-Gear transmission and/or Hydro-Gear drive components, the Hydro-Gear transmission and/or drive components are covered only by the warranty made by Hydro-Gear, and are not covered by this warranty.
- This warranty applies only to products purchased in the United States (including Puerto Rico) and Canada. In all other countries, contact place of purchase.

Gravely may from time to time change the design of its products. Nothing contained in this warranty shall be construed as obligating Gravely to incorporate such design changes into previously manufactured products, nor shall such changes be construed as an admission that previous designs were defective.

LIMITATION OF REMEDY AND DAMAGES

Gravely's liability under this express warranty, and under any implied warranty that may exist, is limited to repair or replacement of any defective part. In no event shall Gravely be liable for incidental, special, or consequential damages (including lost profits). This warranty gives you specific legal rights. You may also have other rights which vary from state to state. Some states do not allow the exclusion of incidental or consequential damages, or limitations on how long an implied warranty lasts, so the above limitations and exclusions may not apply to you.

DISCLAIMER OF FURTHER WARRANTY

Gravely makes no warranty other than what is expressly made in this warranty. If the law of your state provides that an implied warranty of merchantability, or an implied warranty of fitness for a particular purpose, applies to Gravely, any such implied warranty is limited to the duration of this express warranty.

Form: GLW2-122002



GRAVELY

A Division of Ariens Company

655 West Ryan Street

P.O. Box 157

Brillion, WI 54110-0157

920-756-2141

Fax 920-756-2407

www.gravelly.com

Free Manuals Download Website

<http://myh66.com>

<http://usermanuals.us>

<http://www.somanuals.com>

<http://www.4manuals.cc>

<http://www.manual-lib.com>

<http://www.404manual.com>

<http://www.luxmanual.com>

<http://aubethermostatmanual.com>

Golf course search by state

<http://golfingnear.com>

Email search by domain

<http://emailbydomain.com>

Auto manuals search

<http://auto.somanuals.com>

TV manuals search

<http://tv.somanuals.com>