

# HTX 2030

313888E  
EN

**-For Portable Airless and Air-Assisted Spraying of Water-Based Architectural Coatings with Base Coat Pump-  
-For Airless Spraying Architectural Coatings and Paints with Top Coat Pump-**



## IMPORTANT SAFETY INSTRUCTIONS

Read all warnings and instructions in this manual. Save these instructions.

**Model Number: 257369 (HTX2030 FreeFlo Inline Gun)**  
**Model Number: 278675 (HTX2030 AirSpray Trigger Gun)**

### Maximum Working Pressure:

**Base Coat Pump:** 1000 psi (69 bar, 6.9 MPa)

**Top Coat Pump:** 3300 psi (228 bar, 22.8 MPa)

### Related Manuals

- 313891 - Operation (French)
- 313893 - Operation (Spanish)
- 313889 - Repair (English)
- 313892 - Repair (French)
- 313893 - Repair (Spanish)
- 313890 - Parts
- 313895 - HTX 2030 Flex Head and Pole Spray Applicator (English)
- 313896 - HTX 2030 Flex Head and Pole Spray Applicator (French)
- 313897 - HTX 2030 Flex Head and Pole Spray Applicator (Spanish)
- 310894 - Displacement Pump (Top Coat)
- 308491 - Airless Heavy Duty Texture Gun
- 313537 - HTX 2030 FreeFlo Inline Gun (English)
- 313603 - HTX 2030 FreeFlo Inline Gun (Chinese)
- 313908 - HTX 2030 FreeFlo Inline Gun (French)
- 313911 - HTX 2030 FreeFlo Inline Gun (Spanish)
- 332160 - HTX2030 AirSpray Trigger Gun (English)
- 332227 - HTX2030 AirSpray Trigger Gun (French)
- 332228 - HTX2030 AirSpray Trigger Gun (Spanish)
- 332229 - HTX2030 AirSpray Trigger Gun (Chinese)

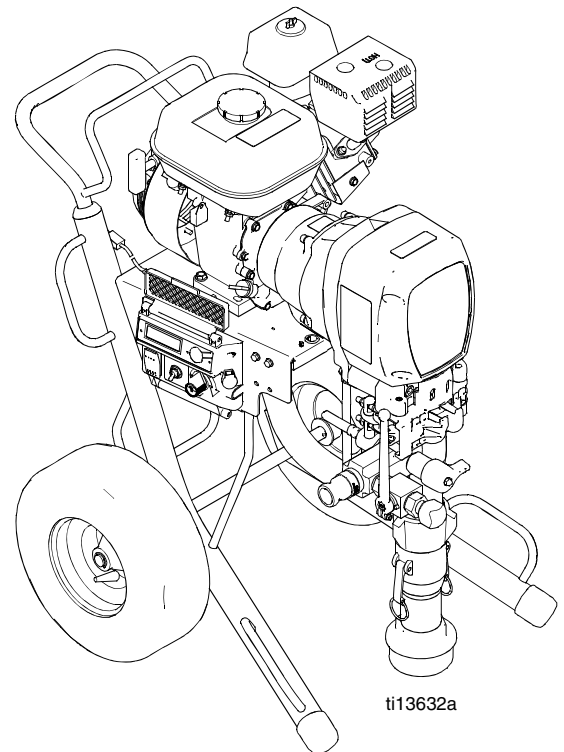





# Contents









<b>Contents</b> .....	<b>2</b>
<b>Warnings</b> .....	<b>3</b>
<b>Product Overview</b> .....	<b>5</b>
HTX 2030 with Base Coat Pump (257369) .....	5
Top Coat Pump (Kit 24B140) .....	6
<b>Component Identification - Sprayer</b> .....	<b>7</b>
<b>Component Identification - Base Coat Applicator</b>	<b>8</b>
<b>Component Identification - HTX2030 Air Spray</b>	
<b>Trigger Gun</b> .....	<b>9</b>
<b>Grounding</b> .....	<b>10</b>
<b>Pressure Relief Procedure</b> .....	<b>10</b>
Applicator (Base Coat Pump) .....	10
Spray Gun (Top Coat Pump) .....	11
<b>Start Engine</b> .....	<b>12</b>
<b>Setup</b> .....	<b>13</b>
Material and Sprayer Preparation .....	13
Prime Pump .....	13
Spray With Airless Tip .....	14
Spray Without Air - Clear Clog .....	15
Air Assisted Spray (Base Coat Applicator) .....	15
Air Assisted Spray (Air Spray Trigger Gun) .....	16
Spray Gun (Top Coat Pump) .....	17
<b>Cleanup</b> .....	<b>18</b>
<b>Digital Tracking System (DTS)</b> .....	<b>21</b>
Main Menu .....	21
Secondary Menu - Stored Data Mode .....	22
<b>Digital Display Messages</b> .....	<b>23</b>
<b>Maintenance</b> .....	<b>24</b>
<b>Technical Data</b> .....	<b>25</b>
Dimensions .....	25
<b>Notes</b> .....	<b>26</b>
<b>Notes</b> .....	<b>27</b>
<b>Graco Standard Warranty</b> .....	<b>28</b>

# Warnings

The following warnings are for the setup, use, grounding, maintenance, and repair of this equipment. The exclamation point symbol alerts you to a general warning and the hazard symbols refer to procedure-specific risks. When these symbols appear in the body of this manual or on warning labels, refer back to these Warnings. Product-specific hazard symbols and warnings not covered in this section may appear throughout the body of this manual where applicable.

 <h2 style="margin: 0;">WARNING</h2>	
	<p><b>FIRE AND EXPLOSION HAZARD</b></p> <p>Flammable fumes, such as solvent and paint fumes, in <b>work area</b> can ignite or explode. To help prevent fire and explosion:</p> <ul style="list-style-type: none"> <li>• Use equipment only in well ventilated area.</li> <li>• Do not fill fuel tank while engine is running or hot; shut off engine and let it cool. Fuel is flammable and can ignite or explode if spilled on hot surface.</li> <li>• Eliminate all ignition sources; such as pilot lights, cigarettes, portable electric lamps, and plastic drop cloths (potential static arc).</li> <li>• Keep work area free of debris, including solvent, rags and gasoline.</li> <li>• Do not plug or unplug power cords, or turn power or light switches on or off when flammable fumes are present.</li> <li>• Ground all equipment in the work area. See <b>Grounding</b> instructions.</li> <li>• Use only grounded hoses.</li> <li>• Hold gun firmly to side of grounded pail when triggering into pail. Do not use pail liners unless they are antistatic or conductive.</li> <li>• <b>Stop operation immediately</b> if static sparking occurs or you feel a shock. Do not use equipment until you identify and correct the problem.</li> <li>• Keep a working fire extinguisher in the work area.</li> </ul>
	<p><b>SKIN INJECTION HAZARD (SPRAY GUN)</b></p> <p>High-pressure fluid from gun, hose leaks, or ruptured components will pierce skin. This may look like just a cut, but it is a serious injury that can result in amputation. <b>Get immediate surgical treatment.</b></p> <ul style="list-style-type: none"> <li>• Do not point gun at anyone or at any part of the body.</li> <li>• Do not put your hand over the spray nozzle.</li> <li>• Do not stop or deflect leaks with your hand, body, glove, or rag.</li> <li>• Follow <b>Pressure Relief Procedure</b> in this manual when you stop spraying and before cleaning, checking, or servicing equipment.</li> </ul>
	<p><b>SKIN INJECTION HAZARD (APPLICATOR AND AIR SPRAY TRIGGER GUN)</b></p> <p>High-pressure fluid from dispensing device, hose leaks, or ruptured components will pierce skin. This may look like just a cut, but it is a serious injury that can result in amputation. <b>Get immediate surgical treatment.</b></p> <ul style="list-style-type: none"> <li>• Do not point dispensing device at anyone or at any part of the body.</li> <li>• Do not put your hand over the fluid outlet.</li> <li>• Do not stop or deflect leaks with your hand, body, glove, or rag.</li> <li>• Follow the <b>Pressure Relief Procedure</b> when you stop dispensing and before cleaning, checking, or servicing equipment.</li> <li>• Tighten all fluid connections before operating the equipment.</li> <li>• Check hoses and couplings daily. Replace worn or damaged parts immediately.</li> </ul>
	<p><b>MOVING PARTS HAZARD</b></p> <p>Moving parts can pinch, cut or amputate fingers and other body parts.</p> <ul style="list-style-type: none"> <li>• Keep clear of moving parts.</li> <li>• Do not operate equipment with protective guards or covers removed.</li> <li>• Pressurized equipment can start without warning. Before checking, moving, or servicing equipment, follow the <b>Pressure Relief Procedure</b> and disconnect all power sources.</li> </ul>

# ! WARNING

	<p><b>RECOIL HAZARD</b> Gun may recoil when triggered. If you are not standing securely, you could fall and be seriously injured.</p>
	<p><b>PRESSURIZED ALUMINUM PARTS HAZARD</b> Use of fluids that are incompatible with aluminum in pressurized equipment can cause serious chemical reaction and equipment rupture. Failure to follow this warning can result in death, serious injury, or property damage.</p> <ul style="list-style-type: none"> <li>Do not use 1,1,1-trichloroethane, methylene chloride, other halogenated hydrocarbon solvents or fluids containing such solvents.</li> <li>Many other fluids may contain chemicals that can react with aluminum. Contact your material supplier for compatibility.</li> </ul>
	<p><b>SUCTION HAZARD</b> Powerful suction could cause serious injury.</p> <ul style="list-style-type: none"> <li>Never place hands near the pump fluid inlet when pump is operating or pressurized.</li> </ul>
	<p><b>CARBON MONOXIDE HAZARD</b> Exhaust contains poisonous carbon monoxide, which is colorless and odorless. Breathing carbon monoxide can cause death.</p> <ul style="list-style-type: none"> <li>Do not operate in an enclosed area.</li> </ul>
	<p><b>TOXIC FLUID OR FUMES HAZARD</b> Toxic fluids or fumes can cause serious injury or death if splashed in the eyes or on skin, inhaled, or swallowed.</p> <ul style="list-style-type: none"> <li>Read MSDSs to know the specific hazards of the fluids you are using.</li> <li>Store hazardous fluid in approved containers, and dispose of it according to applicable guidelines.</li> </ul>
	<p><b>BURN HAZARD</b> Equipment surfaces and fluid that's heated can become very hot during operation. To avoid severe burns:</p> <ul style="list-style-type: none"> <li>Do not touch hot fluid or equipment.</li> </ul>
	<p><b>PERSONAL PROTECTIVE EQUIPMENT</b> Wear appropriate protective equipment when in the work area to help prevent serious injury, including eye injury, hearing loss, inhalation of toxic fumes, and burns. This protective equipment includes but is not limited to:</p> <ul style="list-style-type: none"> <li>Protective eyewear, and hearing protection.</li> <li>Respirators, protective clothing, and gloves as recommended by the fluid and solvent manufacturer.</li> </ul>
	<p><b>EQUIPMENT MISUSE HAZARD</b> Misuse can cause death or serious injury.</p> <ul style="list-style-type: none"> <li>Do not operate the unit when fatigued or under the influence of drugs or alcohol.</li> <li>Do not exceed the maximum working pressure or temperature rating of the lowest rated system component. See <b>Technical Data</b> in all equipment manuals.</li> <li>Use fluids and solvents that are compatible with equipment wetted parts. See Technical Data in all equipment manuals. Read fluid and solvent manufacturer's warnings. For complete information about your material, request MSDS from distributor or retailer.</li> <li>Do not leave the work area while equipment is energized or under pressure.</li> <li>Turn off all equipment and follow the <b>Pressure Relief Procedure</b> when equipment is not in use.</li> <li>Check equipment daily. Repair or replace worn or damaged parts immediately with genuine manufacturer's replacement parts only.</li> <li>Do not alter or modify equipment. Alterations or modifications may void agency approvals and create safety hazards.</li> <li>Make sure all equipment is rated and approved for the environment in which you are using it.</li> <li>Use equipment only for its intended purpose. Call your distributor for information.</li> <li>Route hoses and cables away from traffic areas, sharp edges, moving parts, and hot surfaces.</li> <li>Do not kink or over bend hoses or use hoses to pull equipment.</li> <li>Keep children and animals away from work area.</li> <li>Comply with all applicable safety regulations.</li> </ul>

# Product Overview

## HTX 2030 with Base Coat Pump (257369)

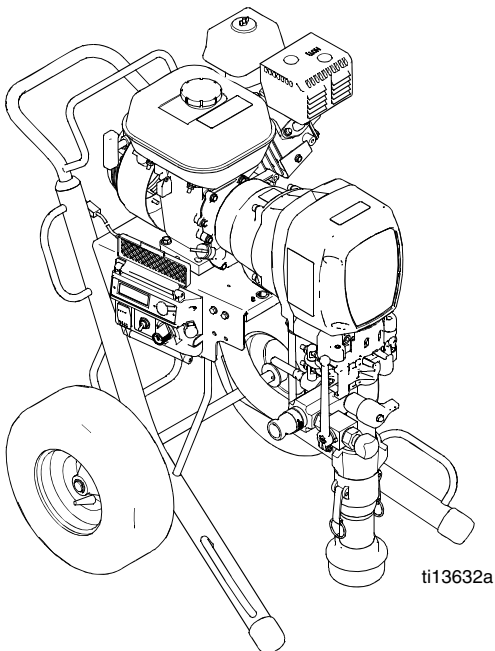

The HTX 2030 Sprayer comes equipped with a Base Coat Pump 24B321. Only water-based materials are to be used with this configuration, such as:

- Smooth to heavily aggregated textures with silica sand, perlite, vermiculite and polystyrene
- Smooth, medium, coarse and extra coarse textures
- Most materials with aggregates up to 2.5 mm (.100 in.) in longest dimension

### When Base Coat Pump is Installed

Pump will only run when on/off switch is in ON position AND:

- Pump control is rotated clockwise away from OFF position, and either of the following switches are also switched ON:

**Prime Switch** on pressure control box AND/OR

**Applicator Switch** near end of material hose

The pressure control will limit the sprayer to 1,000 psi (69 bar), stopping the pump whenever pressure limit is reached.

Flow rate is dependent on engine speed and the setting of the pump control knob.

1. Flow 3 (fully clockwise) - allows the pump to run continuously with minimal pulsation:

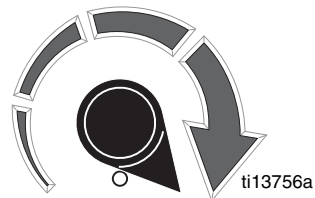

2. Flow 2 (near middle of the rotation) reduces flow slightly by briefly interrupting pump:



3. Flow 1 (near counterclockwise end of pump control) reduces flow more by interrupting pump longer:



4. OFF (fully counterclockwise) - stops pump completely:

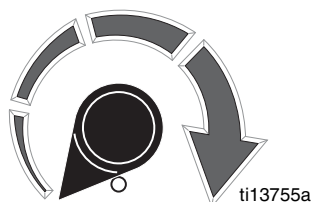

5. Adjust engine speed to control flow rate of sprayer. Start with the slowest speed possible for maximum spray control. Different spray tip nozzle sizes can also be tried.

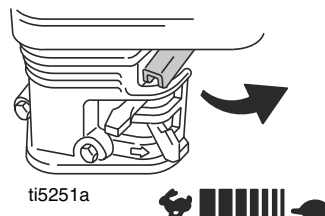

## Top Coat Pump (Kit 24B140)

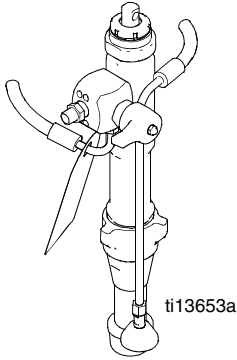

The pump on the HTX 2030 Sprayer can also be switched out with a Top Coat Kit 24B140 (**purchased separately**). This pump is used for less viscous materials such as:

- Oil-based coatings
- Enamels
- Latex
- Block fillers
- Elastomers
- Epoxies
- Drywall mud
- Other high-build materials

For instructions on installing the Top Coat Pump, see manual 313889.

### When Top Coat Pump is Installed

- Pump will only run when on/off switch is in ON position and pump control is rotated clockwise away from OFF position
- Pump control setting adjusts sprayer pressure
  - a. Rotating knob fully clockwise allows sprayer to reach maximum working pressure of 3300 psi (228 bar, 22.8 MPa)
  - b. Settings below maximum will lower system pressure
- Pump will run whenever system pressure is below the setting of the pump control
- Sprayer will not respond to Prime switch or Applicator switch when Top Coat pump is installed

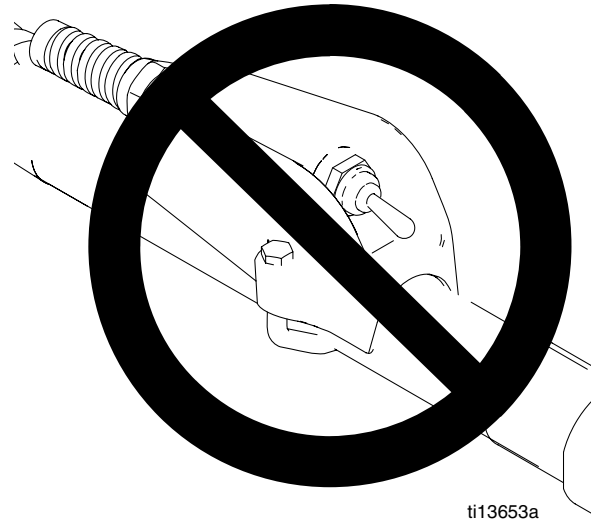

# Component Identification - Sprayer

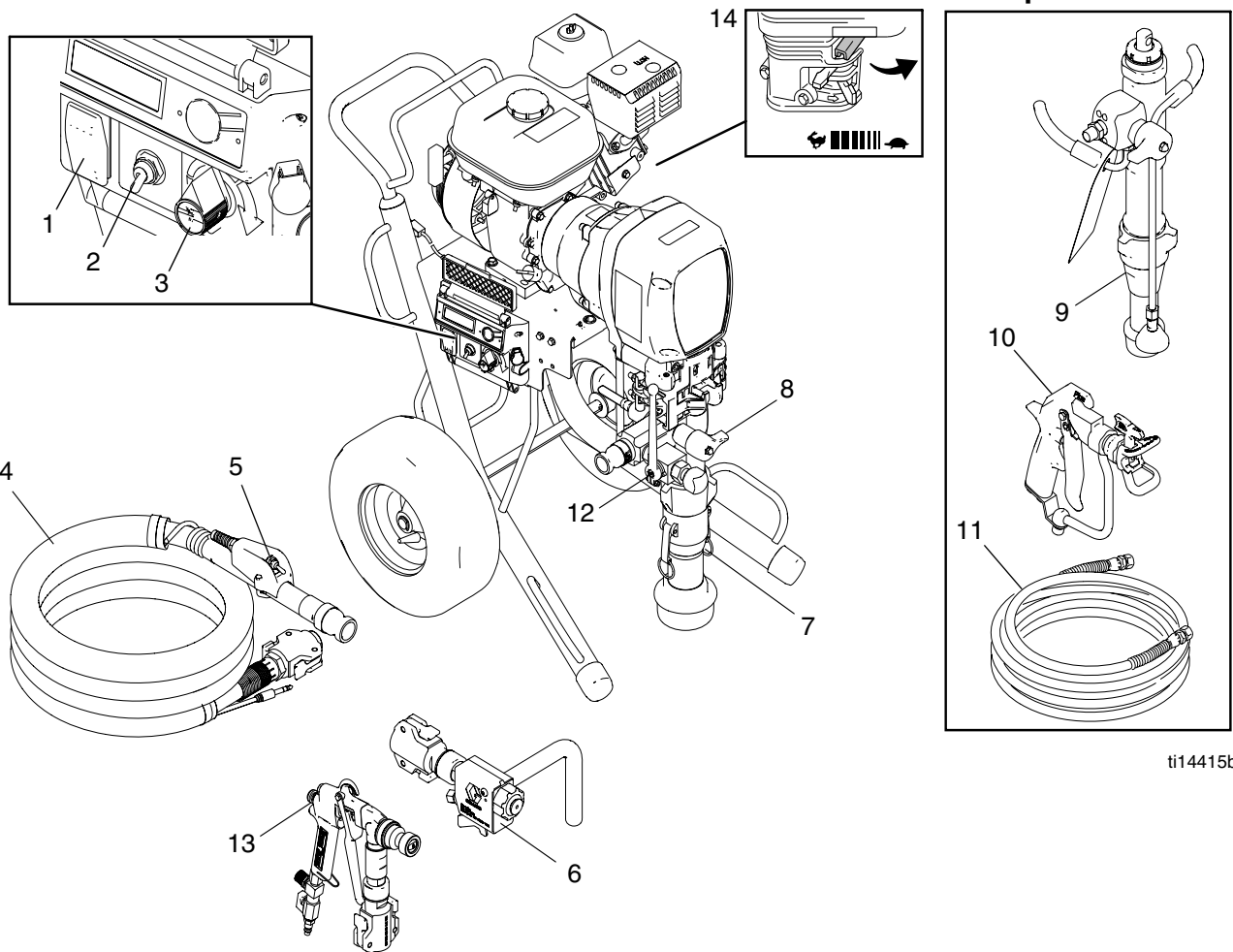

ti14415b

1	ON/OFF Switch
2	Prime Switch (used with Base Coat Pump)
3	Pump Control Knob
4	Heavy Texture Material Hose (used with Base Coat Pump)
5	Applicator Switch (used with Base Coat Pump--on Hose)
6	Applicator (Base Coat) (Model 257369)
7	Pump (Base Coat)
8	Over Pressure Relief Valve
9	Pump (Top Coat)
10	Spray Gun (Top Coat)
11	Paint/Texture Material Hose (used with Top Coat Pump)
12	Prime/Drain Valve
13	Air Spray Gun (24R054)
14	Engine Throttle Lever/Material Flow

# Component Identification - Base Coat Applicator

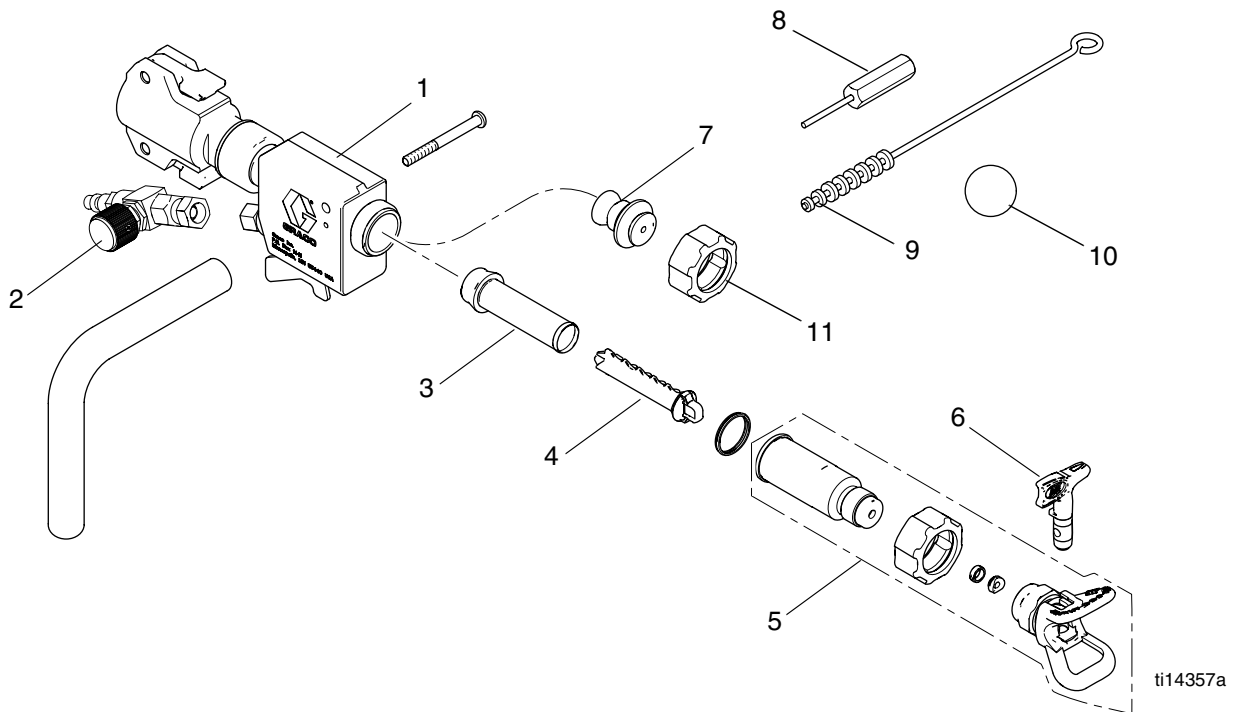

1	Applicator
2	Air Hose Adapter and Air Adjustment Valve
3	Airless Filter or Air Passage Plug
4	Filter Support
5	Airless Spray Assembly
6	Airless Spray Tip Nozzle
7	Air Nozzle (4 mm, 6mm, 8mm, 10mm)
8	Air Nozzle Cleaner
9	Cleaning Brush
10	Cleaning Ball
11	Retaining Nut



# Component Identification - HTX2030 Air Spray Trigger Gun

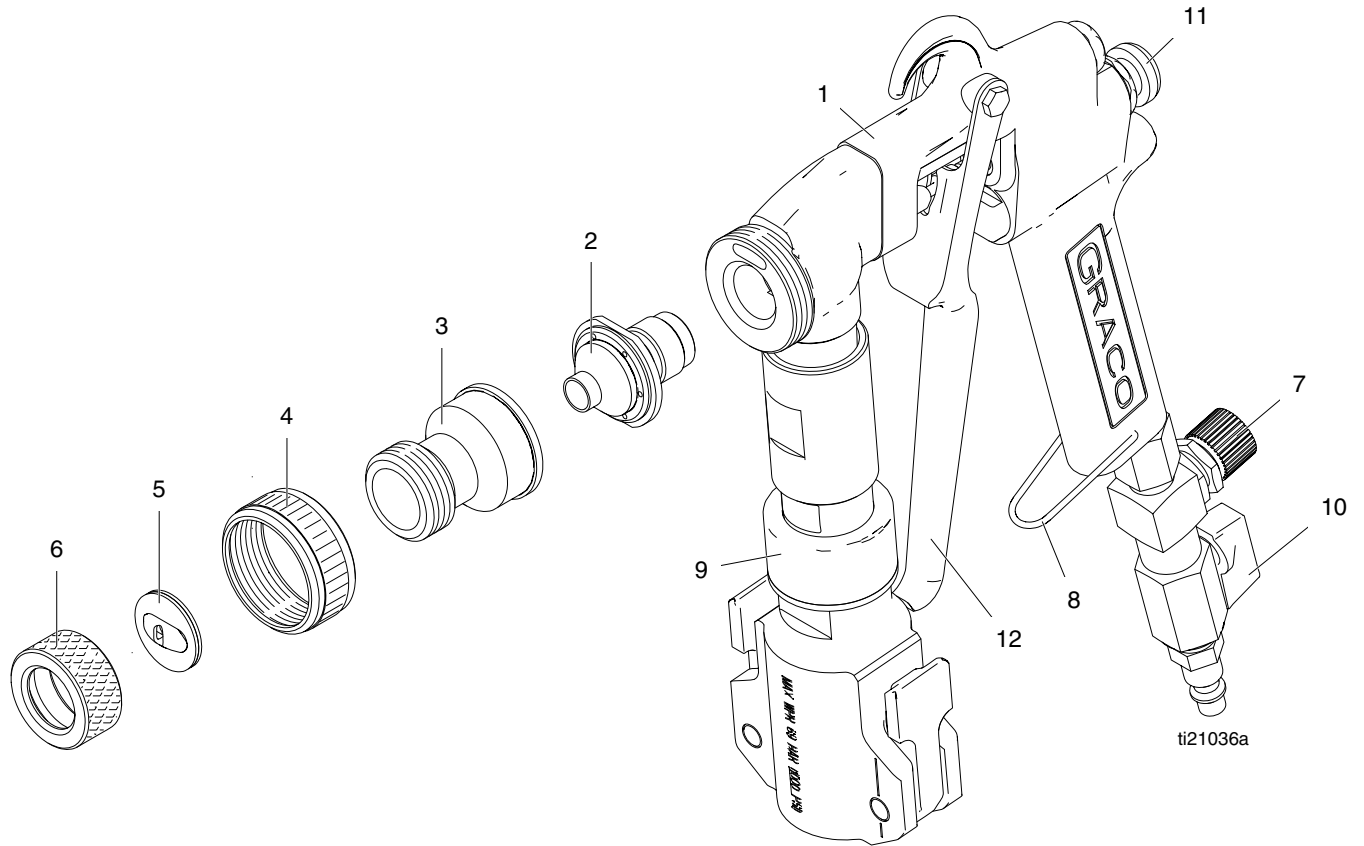

1	HTX2030 Air Spray Trigger Gun
2	Nozzle, Size #1, Size #2, Size #3
3	Adapter, Housing
4	Ring, Retaining Nozzles
5	Tip, Disc, Spray, 1/8 in. (3 mm), 1/4 in. (6.3 mm), 5/16 in. (8 mm), 3/8 in. (9.5 mm)
6	Ring, Retaining, Spray Discs
7	Air Adjustment Valve
8	Trigger, Latch On
9	HTX Swivel Assembly
10	Air, Control Ball Valve
11	Flow, Adjust Knob
12	Trigger

# Grounding

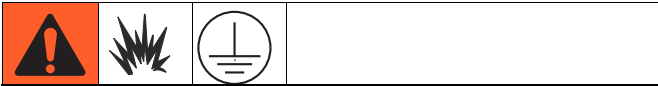

The equipment must be grounded to reduce the risk of static sparking. Static sparking can cause fumes to ignite or explode. Grounding provides an escape wire for the electric current.

Ground sprayer with grounding clamp to earth ground when flushing sprayer.

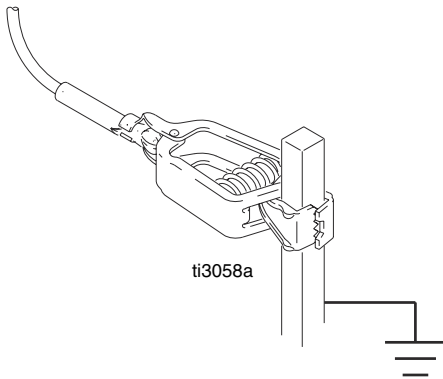

To maintain grounding continuity when flushing or relieving pressure: Hold metal part of the spray gun firmly to the side of a grounded metal pail, then trigger the gun/valve.

# Pressure Relief Procedure

## Applicator and Air Spray Trigger Gun (Base Coat Pump)



Follow the Pressure Relief Procedure whenever you see this symbol.



This equipment stays pressurized until pressure is manually relieved. To help prevent serious injury from pressurized fluid, such as skin injection, splashing fluid and moving parts, follow the **Pressure Relief Procedure** when you stop spraying and before cleaning, checking, or servicing the equipment.

1. Turn engine OFF.

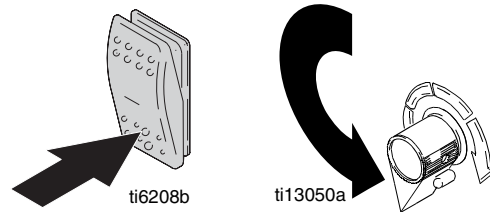

2. Turn on/off switch OFF and turn pressure control knob fully counterclockwise.

3. **HTX2030 Air Spray Trigger Gun only:** Pull gun trigger to release pressure.

4. Turn prime/drain valve down to DRAIN position. Fluid from drain valve can splash in eyes or skin and cause serious injury. Keep hands clear of pressure relief valve and always wear safety glasses.

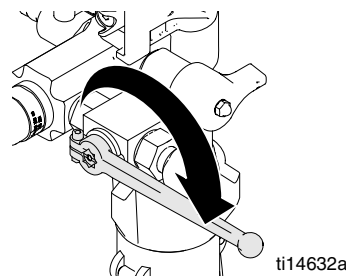

**NOTE:** If you suspect spray tip nozzle or hose is completely clogged or that pressure has not been fully relieved after following the previous steps, cover the connection at end of hose with a heavy rag and **very slowly** loosen connection.

## Spray Gun (Top Coat Pump)



1. Lock gun trigger safety and turn engine OFF.

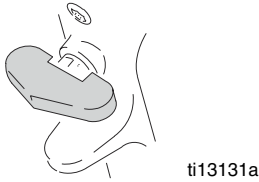

2. Turn on/off switch to OFF and turn pressure control knob fully counterclockwise.

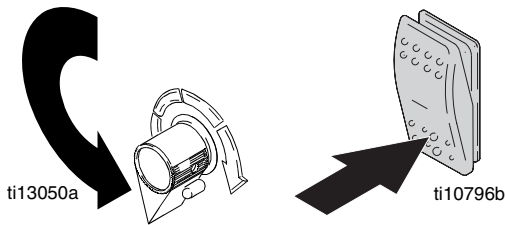

3. Unlock trigger safety. Hold metal part of gun firmly to side of grounded metal pail and trigger gun to relieve pressure.

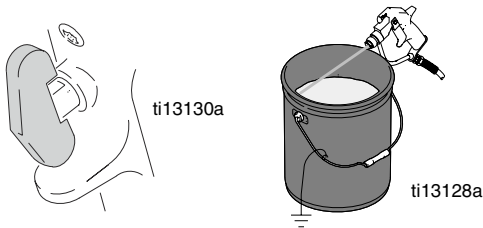

4. Lock gun trigger safety. Open pressure prime/drain valve. Leave valve open until ready to spray again.

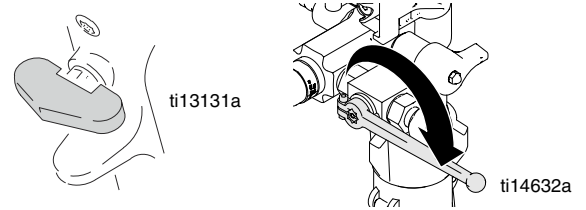

**NOTE:** If you suspect that the spray tip nozzle or hose is completely clogged, or that pressure has not been fully relieved after following the previous steps, **VERY SLOWLY** loosen the tip guard retaining nut or hose end coupling to relieve pressure gradually, then loosen completely. Then clear tip or hose.

# Start Engine

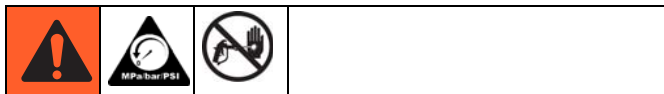

1. Move fuel valve to OPEN.

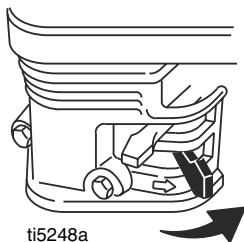

2. Move choke to CLOSED.

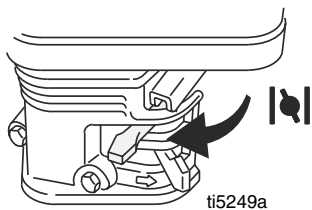

3. Set throttle to FAST.

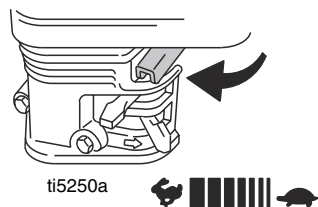

4. Set engine switch to ON.

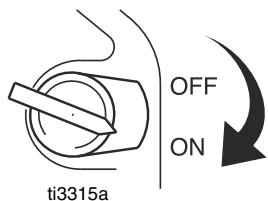

5. Pull starter rope.

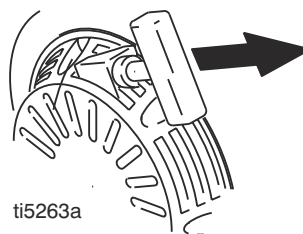

6. After engine starts, move choke to OPEN.

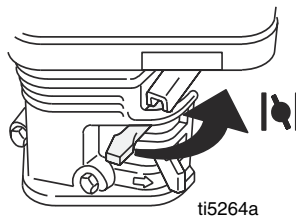

7. Set throttle to desired setting.

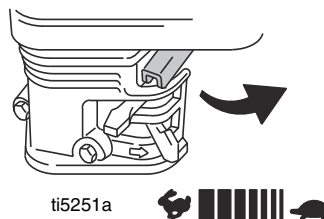

# Setup

## NOTICE

**DO NOT USE MATERIALS THAT CURE RAPIDLY!**  
Materials with a fast curing time could plug the pump, hose, gun, or applicator.

1. Fill mixing pail with pre-mixed texture material. Mix per material manufacturer instructions.

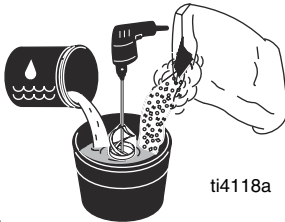

2. Connect material hose to pump outlet.

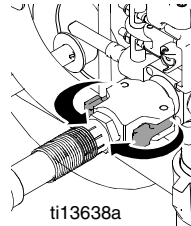
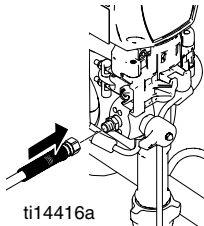

## Material and Sprayer Preparation

**NOTE:** To minimize material pack-out in hose when priming, completely empty hose of all water. In hot conditions, it may be necessary to wet the hose with water to lower internal hose temperature, slowing material setup. In this case, water removal is still recommended. If using hose lubricant/wetting solutions, refer to manufacturer instructions for proper priming techniques.

Cementitious and other curing materials can harden within the drain valve while spraying. At least once per hour stop spraying and open the drain valve to flush out the older material.

3. Pour mixed material into supply pail under sprayer.
4. Place pump suction tube into mixed material.

**NOTE:** For best results with aggregate, remove strainer.

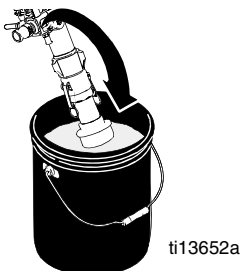

## Prime Pump

1. Start gasoline engine and adjust speed to half throttle. Turn prime/drain valve to DRAIN.

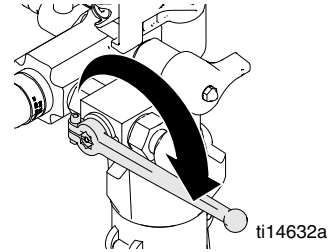

2. Place material hose outlet over supply pail.

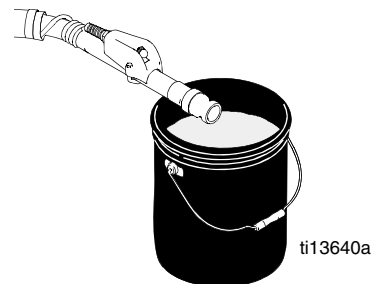

3. Turn on/off switch ON.

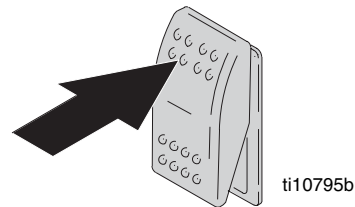

## Base Coat Pump:

Also turn Prime switch ON, or activate applicator switch on material hose.

4. Rotate pump control knob 1/4 turn. Run pump until a steady stream of material flows from drain valve.

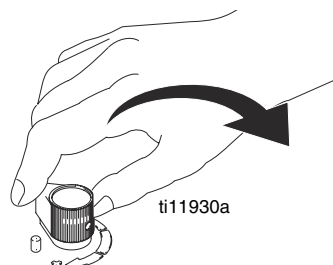

5. Turn on/off switch OFF and turn drain valve knob to SPRAY.

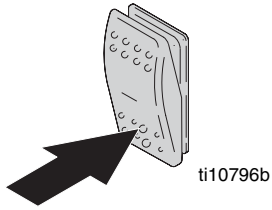

6. Turn on/off switch ON, and run pump until a steady stream of material flows from material hose. Turn on/off switch to OFF and turn drain valve knob to DRAIN.

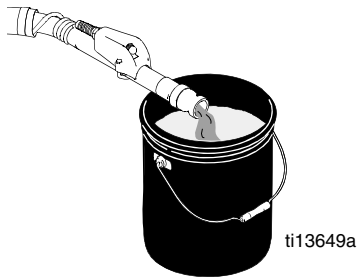

7. Connect applicator to material hose.

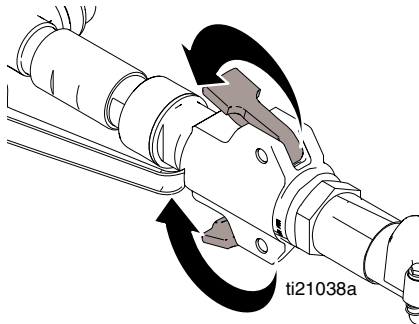

## Spray With Airless Tip

1. Install filter and tip extension.

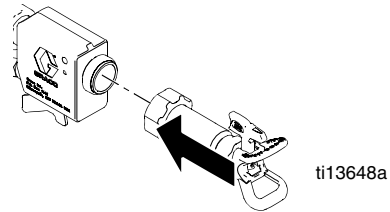

2. Insert metal seat and OneSeal. Insert Switch Tip. Screw assembly onto applicator.

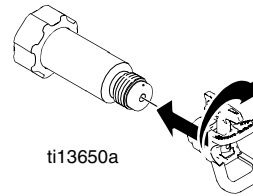
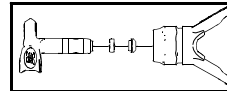

3. Turn drain valve to SPRAY, and turn on/off switch to ON. Turn pump control knob clockwise and/or adjust engine speed until desired material delivery rate is achieved.

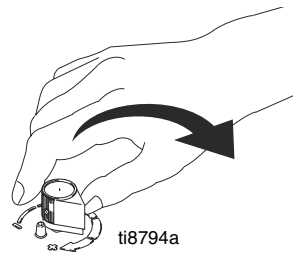

4. Spray test pattern. Aim applicator at floor. Turn applicator switch ON and move applicator to spray surface.

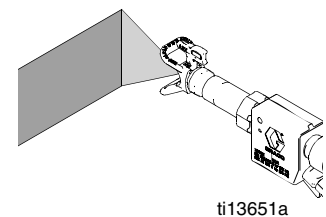
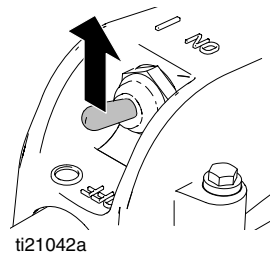

## Spray Without Air - Clear Clog

1. **Relieve Pressure**, page 10.
2. Rotate SwitchTip to Clear position. Aim applicator at floor and turn pump ON. When clog clears, turn pump OFF.



3. Rotate SwitchTip to Spray position. Turn pump ON. Spray test pattern.



## Air Assisted Spray (Base Coat Applicator)

1. Prepare material, page 13. Place material hose in supply pail.
2. Turn on/off switch OFF.

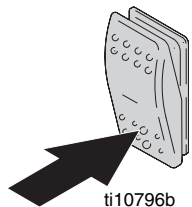

3. Remove cap and install air valve assembly.

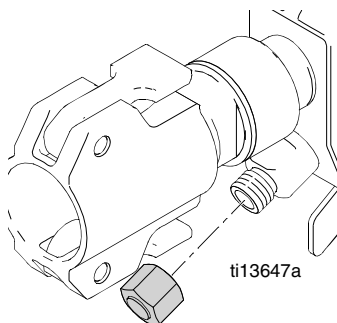

4. Turn air valve OFF. Connect applicator to material hose and air hose. Air supply minimum requirements vary with material thickness and desired thickness.

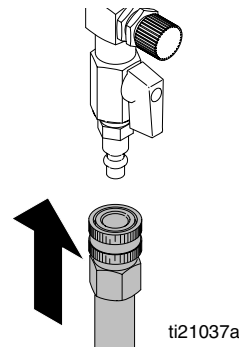

### NOTICE

**DO NOT USE MATERIALS THAT CURE RAPIDLY!**  
Materials with a fast curing time could plug the pump hose, gun, or applicator.

5. Turn on/off switch ON.

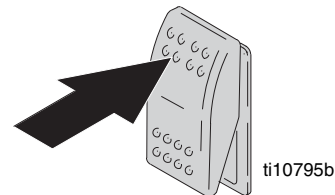

6. Hold applicator over material pail and turn pump ON using applicator switch on hose.

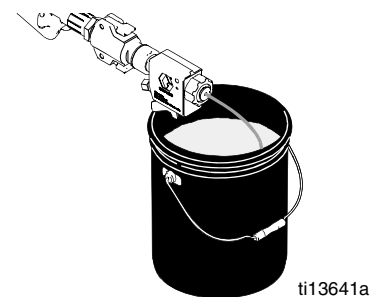

7. Turn pump control clockwise until desired material delivery rate is achieved.

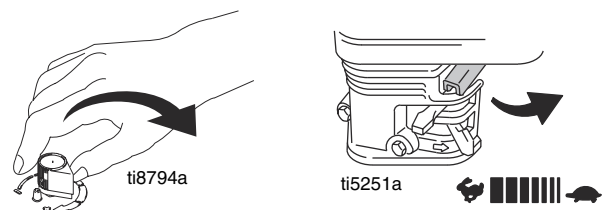

8. Spray test pattern. Aim applicator at floor. Turn air valve ON. Move applicator to spray surface.

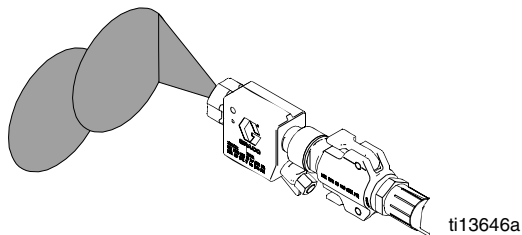

9. Adjust air valve and/or select alternative nozzle size (4 - 10mm) for desired finish.

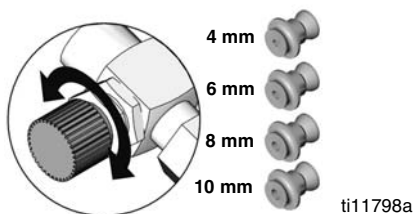

3. Turn air valve OFF. Connect applicator to material hose and air hose. Air supply minimum requirements vary with material thickness and desired thickness.

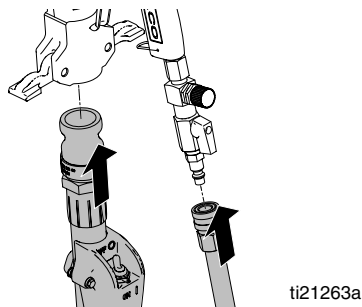

**NOTICE**

**DO NOT USE MATERIALS THAT CURE RAPIDLY!**  
Materials with a fast curing time could plug the pump hose, gun, or applicator.

**NOTICE**

**IF PUMP IS STOPPED LONGER THAN 3 MINUTES, TO AVOID PUMP PLUGGING:**

- Relieve pressure in the pump (See Pressure Relief procedure - page 10).
- Recirculate the material by pumping back into original material container.

## Air Assisted Spray (Air Spray Trigger Gun)

Due to the high pressure fluid emitted, a strong recoil action may occur when you trigger this gun. If you are unprepared, your hand could be forced back toward your body or you could lose your balance and fall, resulting in serious injury.

1. Prepare material, page 13. Place material hose in supply pail.
2. Turn on/off switch OFF.

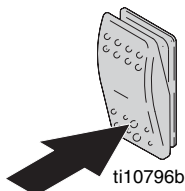

4. Turn on/off switch ON.

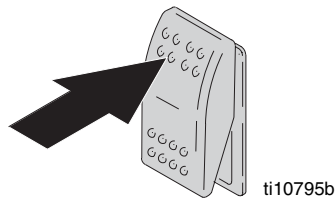

5. Hold applicator over material pail, trigger on, and turn pump ON using applicator switch on hose. **NOTE:** Remove spray disk then set material flow to prevent material from back-flowing into air passages of gun.

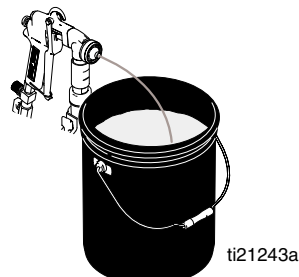

6. Turn pump control clockwise and adjust engine throttle to lowest setting until desired material delivery rate is achieved.

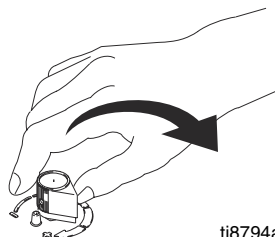



7. Turn air valve on and adjust air valve and/or select alternative nozzles or spray discs to achieve desired pattern.

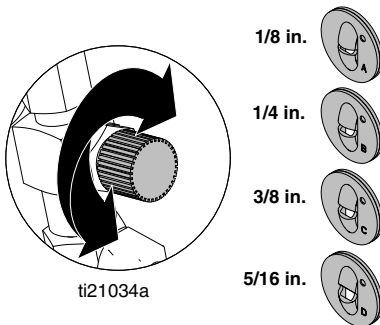

8. Spray test pattern. Move applicator to spray surface. **NOTE:** See Air Spray Trigger Gun manual for helpful hints on spray patterns.

#### NOTICE

- Keep gun triggered as much as possible to prevent pack-out.
- If gun has not been triggered for longer than 3 minutes, perform **Pressure Relief** (page 10) in the pump and hose to prevent packout.
- Turn off applicator switch on hose before detraggering to minimize retained pressure.
- Make sure air is flowing before triggering gun.

## Spray Gun (Top Coat Pump)

1. Lock gun trigger safety. Insert seat and OneSeal™. Insert SwitchTip.

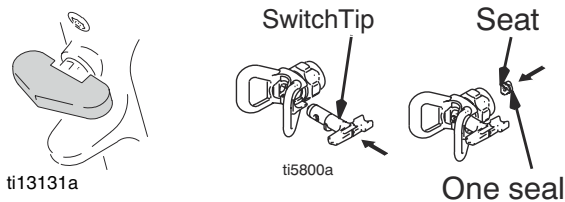

2. Screw assembly onto gun. Hand tighten.

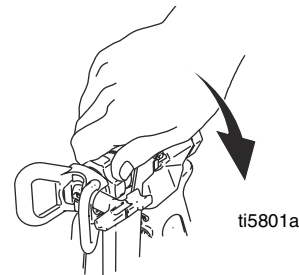

3. Trigger gun and spray test pattern. Slowly adjust pressure to eliminate heavy edges. Use smaller tip size if pressure adjustment can not eliminate heavy edges.

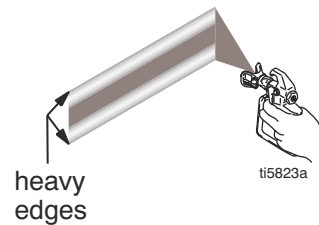

4. Hold gun perpendicular, 10-12 in. (25-30 cm) from surface. Spray back and forth. Use strokes overlapped by 50%. Start gun movement before triggering gun and release trigger before stopping gun movement.

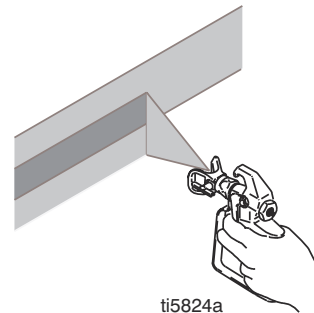

# Cleanup



1. Turn on/off switch OFF.

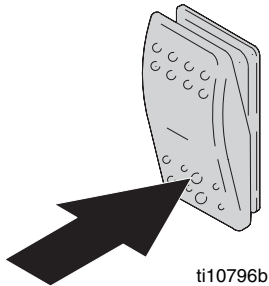

2. Perform **Pressure Relief** procedure, page 10.

3. Place pump in pail of clean water.

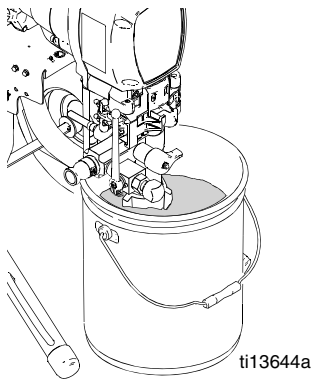

4. Shut OFF air if spraying with air. Remove applicator from material and air hoses.

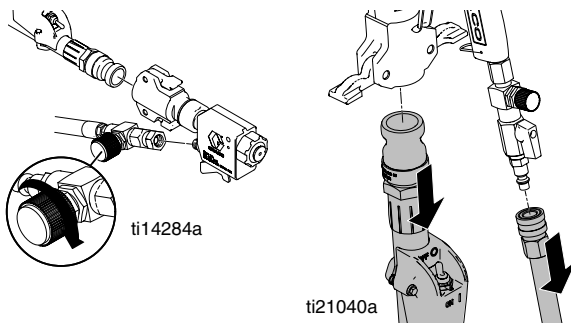

5. **Base Coat Pump:** Disconnect material hose from pump outlet.

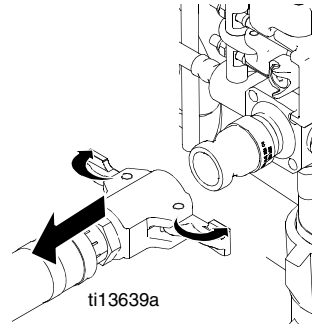

6. Insert wet cleaning ball into hose (Base Coat Only). Connect material hose to pump outlet.

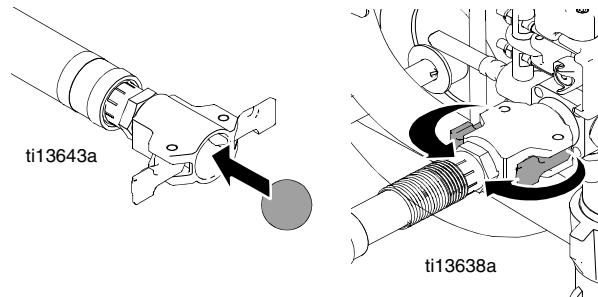

7. Hold material hose over waste pail.

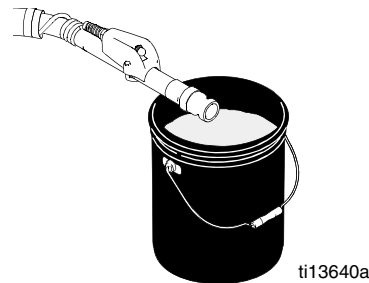

8. Turn on/off switch ON and prime switch ON, or applicator switch on material hose.

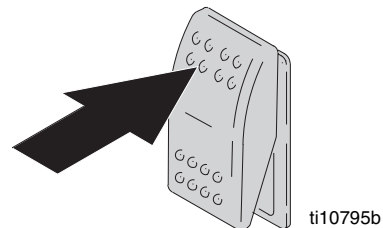

9. Run pump until cleaning ball exits material hose. Save cleaning ball (Base Coat Only).

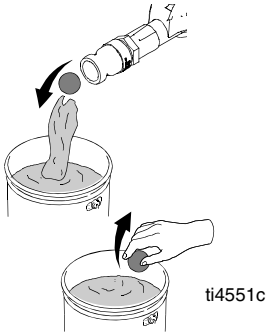

10. Turn on/off switch OFF and turn prime/drain valve to DRAIN. Clean outside of pump and suction tube with brush and water.

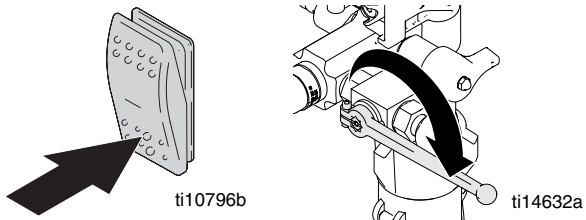

11. Connect applicator to material hose. Close prime/drain valve.

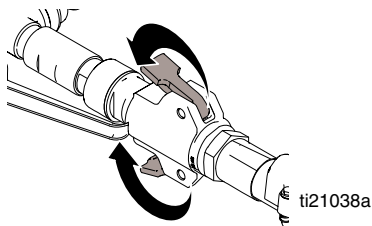

12. Turn on/off switch ON.

**Base Coat Pump:** Turn prime switch ON, or applicator switch on material hose.

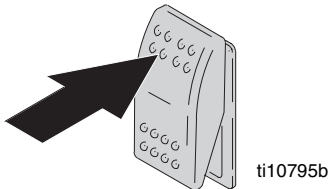

13. Run pump until clean water flows from applicator.

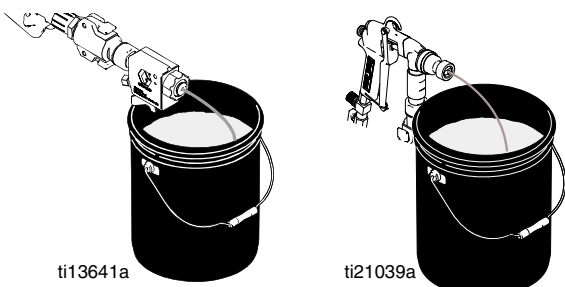

14. Add additional water and repeat steps 12 - 13 if necessary.

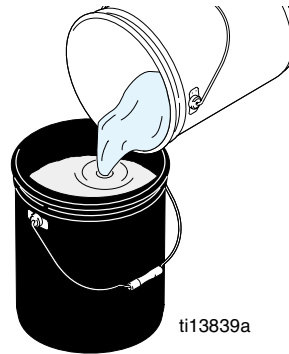

15. Open prime/drain valve and turn prime switch ON to flush valve.

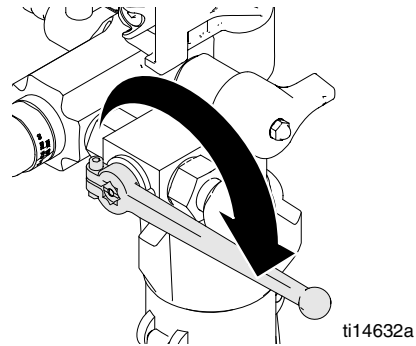

16. Turn on/off switch OFF when valve is thoroughly flushed.

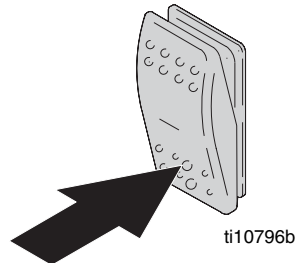

17. Open over pressure relief valve and turn prime switch ON to flush valve.

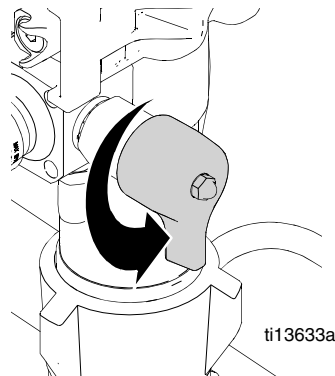

Cleanup

18. Remove and thoroughly clean applicator, spray tip nozzle and guard with brush.
19. Turn on/off switch OFF when valve is thoroughly flushed.
20. Clean hardened material from applicator nozzles with air nozzle cleaner.

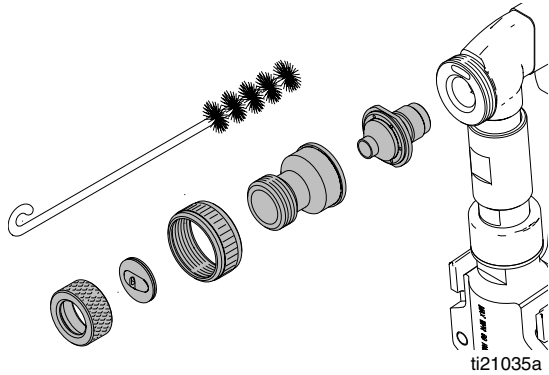
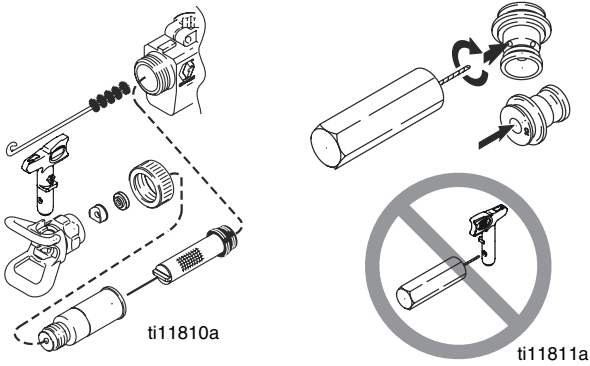

**NOTICE**

Do not use air nozzle cleaner to clean applicator check valve or airless spray tip nozzle. Damage will occur.

**Remove air check valve from applicator to clean hardened material from interior of applicator.**

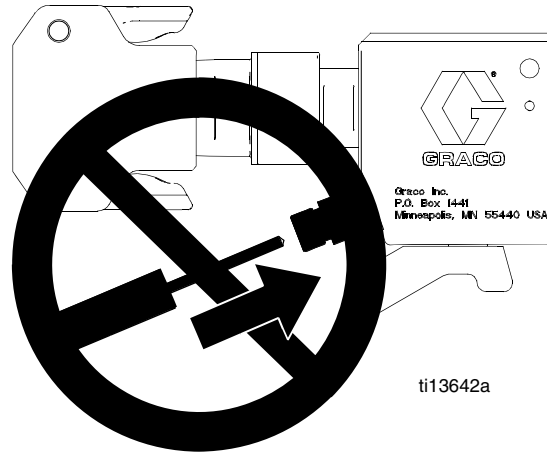

# Digital Tracking System (DTS)

## Main Menu

Close cover when spraying to protect display.



1. Perform **Startup** steps 1 - 2.
  - Open drain valve
  - Turn pump control counterclockwise to lowest setting
  - Set applicator switch to OFF
2. **Start Engine**, page 12. Display will momentarily show which pump is installed (Base or Top) and then Flow 1, 2, or 3 (if **Base Coat** pump is installed). Pressure display appears, then dashes appear when pressure is less than 60 psi (4 bar, 0.4 MPa).



**NOTE:** Information other than pressure cannot be accessed if applicator switch is ON. And, if system pressure is greater than 200 psi (14 bar, 1.4 MPa), the display will revert back to pressure after 3 seconds.

3. Short press DTS button to display installed pump.

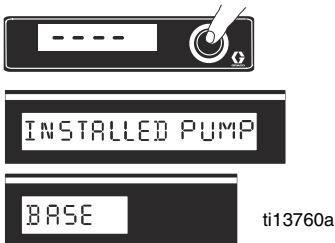

4. Short press DTS button to move to Engine RPM.

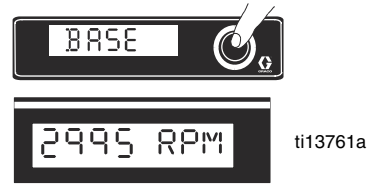

5. Short press DTS button to return to Pressure.

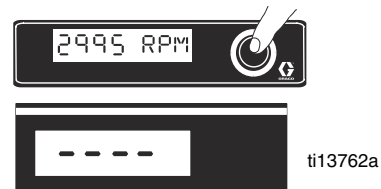

### To Change Pressure Units:

Press and hold (8 seconds) DTS button to change pressure unit (psi, bar, MPa).

Continue to press DTS button to cycle from psi to bar to MPa. Release DTS button to select units.

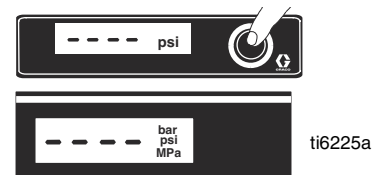

## Secondary Menu - Stored Data Mode

- Open drain valve
- Turn pump control counterclockwise to lowest setting
- Set applicator switch to OFF

1. Start Engine, page 12. Pressure display appears.



2. Press and hold DTS button and turn applicator switch ON.

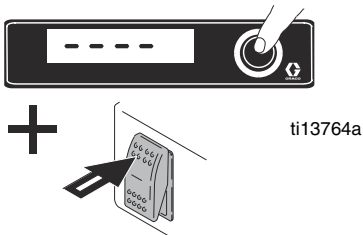

3. SERIAL NUM scrolls through display and a 3 to 5-digit serial number displays.



4. Short press DTS button and date code displays.



5. Short press DTS button and part number displays.



6. Short press DTS button and Base Coat hours displays.

Short press DTS button and Top Coat hours display.

Short press DTS button and Engine hours display.



7. Short press DTS button and LAST ERROR scrolls through display followed by stored error message and error code. This information cycles repeatedly until cleared.

See page 23 for error code explanations.



8. Press and hold DTS button until CLEAR ERROR NO ERROR CODE scrolls through the display and error code E=00 displays.



9. Short press DTS button again and SOFTWARE REV scrolls through display followed by revision level (for example 10102).





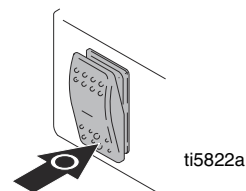



10. Short press to return to step 3. Turn on/off switch OFF at any time to exit stored data mode.



# Digital Display Messages



DISPLAY*	SPRAYER OPERATION	INDICATION	ACTION
No Display	Sprayer may be pressurized	Loss of power or display not connected	Check power source. Relieve pressure before repair or disassembly. Verify display is connected.
 ti6314a	Sprayer may be pressurized	Pressure less than 60 psi (4 bar, 0.4 MPa)	Increase pressure as needed
<b>BASE</b> or <b>TOP</b>	Displays installed pump when engine is started	Normal operation	Spray
<b>OFF FLOW 1</b> <b>FLOW 2</b> or <b>FLOW 3</b>	Displays flow control setting in Base Coat mode when pump control setting is changed	Normal operation (with Base Coat pump)	Spray
 ti6315a	Sprayer is pressurized. Power is applied. (Pressure varies with tip size and pressure control setting.)	Normal operation	Spray
 ti6316a	<b>Top Coat Only:</b> Sprayer stops. Engine is running.	Pressure greater than 4500 psi (310 bar, 31 MPa)	<ol style="list-style-type: none"> <li>1 Check fluid path for clogs.</li> <li>2 Use Graco paint hose, 3/8 in. x 50 ft minimum. Smaller hose or metal braid hose may result in pressure spikes.</li> <li>3 Replace transducer if fluid path is not clogged and proper hose is used.</li> </ol>
 ti6317a	Sprayer stops. Engine is running.	Pressure transducer faulty, bad connection or broken wire	<ol style="list-style-type: none"> <li>1 Check transducer connection.</li> <li>2 Disconnect and reconnect transducer plug to ensure good connection with control board socket.</li> <li>3 Open prime valve. Replace sprayer transducer with known good transducer and run sprayer. Replace transducer if sprayer runs or control board if sprayer does not run.</li> </ol>
 ti6318a	Sprayer stops. Engine is running.	High clutch current	<ol style="list-style-type: none"> <li>1 Check wiring connections.</li> <li>2 Measure: 1.7 + 0.2Ω across clutch field at 70°F.</li> <li>3 Replace clutch field assembly.</li> </ol>
	<b>Base Coat Only:</b> Sprayer stops. Engine is running.	Pressure greater than 1000 psi (69 bar, 6.9 MPa)	<ol style="list-style-type: none"> <li>1 Open prime valve and gun.</li> <li>2 Verify no flow obstructions. Use Graco texture hoses 3/4 in. x 50 ft minimum.</li> <li>3 Replace transducer if fluid path is not clogged and proper hose is used.</li> </ol>

\* Error codes also appear on control board as a blinking red LED. LED is an alternate to digital messages.

- 1 Remove two screws (71) and swing down cover (130).
- 2 Start engine. Blink count is the same as error code(E=0X).

After a fault, follow these steps to restart sprayer:

- 1 Correct fault condition.
- 2 Turn sprayer OFF.
- 3 Turn sprayer ON.

(E02 and E06 errors will self-correct when system is reduced)

# Maintenance

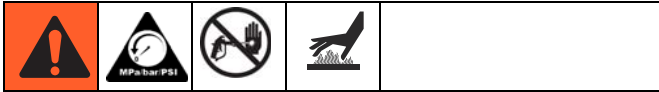

## NOTICE

For detailed engine maintenance and specifications, refer to separate Honda Engines Owner's Manual (supplied).

### DAILY

- Check engine oil level and fill as necessary
- Check hose for wear and damage
- Check that all hose fittings are secure
- Check gun safety for proper operation
- Check and fill the gas tank
- Check level of TSL in displacement pump packing nut. Fill nut, if necessary. Keep TSL in nut to help prevent fluid buildup on piston rod and premature wear of packings and pump corrosion.

### AFTER FIRST 20 HOURS OF OPERATION

- Drain engine oil and refill with clean oil. Reference Honda Engines Owner's Manual for correct oil viscosity.

### WEEKLY

- Remove engine air filter cover and clean element. Replace element if necessary. If operating in an unusually dusty environment, check filter daily and replace (if necessary).

Replacement elements can be purchased from your local Honda dealer.

### AFTER EACH 100 HOURS OF OPERATION

- Change engine oil. Reference Honda Engines Owner's Manual for correct oil viscosity.

### SPARK PLUG

Use only BPR6ES (NGK) or W20EPR-U (NIPPON-DENSO) plug. Gap plug to 0.028 to 0.031 in. (0.7 to 0.8 mm). Use spark plug wrench when installing and removing plug.

### ENGINE OIL FUNNEL

- Use the supplied engine oil funnel when draining oil.

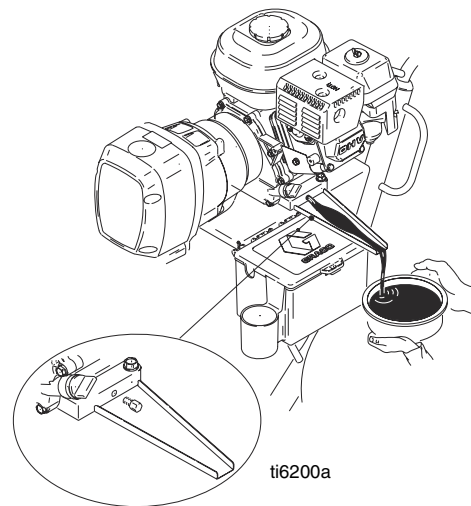



# Technical Data

<b>Honda GX 200 Engine:</b>	
ANSI Power Rating @ 3600 rpm	6.5 Horsepower (4.8 kW)
<b>Maximum Working Pressure:</b>	
Base Coat Pump	1000 psi (69 bar, 6.9 MPa)
Top Coat Pump	3300 psi (228 bar, 22.8 MPa)
<b>Noise Level:</b>	
Sound Power	105 dBa per ISO 3744
Sound Pressure	96 dBa measured at 3.1 ft (1 m)
<b>Maximum Delivery Rating:</b>	
Base Coat Pump	3.0 gpm (11.36 liter/min)
Top Coat Pump	2.20 gpm (8.33 liter/min)
<b>Maximum Tip Size:</b>	
Base Coat Pump	1 applicator with .071 in. tip or 10 mm Nozzle
Top Coat Pump	1 gun with 0.048 in. tip
	2 guns with 0.035 in. tip
	3 guns with 0.027 in. tip
	4 guns with 0.023 in. tip
<b>Inlet Paint Strainer:</b>	
Base Coat Pump	2 in. npsm, #5 mesh sst
Top Coat Pump	1 in. npsm, #8 mesh sst
<b>Pump Inlet Size:</b>	
Base Coat Pump	2 in. QD Camlock male coupler
Top Coat Pump	1 in. - 11.5 npsm
<b>Fluid Outlet Size:</b>	
Base Coat Pump	1 in. QD Camlock male coupler
Top Coat Pump	3/8 npsm
<b>Wetted Parts:</b>	
	zinc-plated carbon steel, PTFE, nylon, polyurethane, UHMW, polyethylene, fluoroelastomer, acetal, leather, aluminum, tungsten carbide, nickel- and zinc-plated carbon steel, stainless steel, chrome plating

## Dimensions

Part	Weight lb (kg)	Height in. (cm)	Width in. (cm)	Length in. (cm)
HTX 2030 Sprayer	155 (70.5)	34.25 (87.0)	24.5 (62.2)	33.0 (83.8)
3/4 in. Hose	29 (13.2)	—	—	—
Applicator/Swivel	3 (1.3)	—	—	—
HTX2030 Air Spray Trigger Gun	3.65 (1.7)	12 (30.5)	1.7 (2.5)	10.4 (26.4)





# Graco Standard Warranty

Graco warrants all equipment referenced in this document which is manufactured by Graco and bearing its name to be free from defects in material and workmanship on the date of sale to the original purchaser for use. With the exception of any special, extended, or limited warranty published by Graco, Graco will, for a period of twelve months from the date of sale, repair or replace any part of the equipment determined by Graco to be defective. This warranty applies only when the equipment is installed, operated and maintained in accordance with Graco's written recommendations.

This warranty does not cover, and Graco shall not be liable for general wear and tear, or any malfunction, damage or wear caused by faulty installation, misapplication, abrasion, corrosion, inadequate or improper maintenance, negligence, accident, tampering, or substitution of non-Graco component parts. Nor shall Graco be liable for malfunction, damage or wear caused by the incompatibility of Graco equipment with structures, accessories, equipment or materials not supplied by Graco, or the improper design, manufacture, installation, operation or maintenance of structures, accessories, equipment or materials not supplied by Graco.

This warranty is conditioned upon the prepaid return of the equipment claimed to be defective to an authorized Graco distributor for verification of the claimed defect. If the claimed defect is verified, Graco will repair or replace free of charge any defective parts. The equipment will be returned to the original purchaser transportation prepaid. If inspection of the equipment does not disclose any defect in material or workmanship, repairs will be made at a reasonable charge, which charges may include the costs of parts, labor, and transportation.

**THIS WARRANTY IS EXCLUSIVE, AND IS IN LIEU OF ANY OTHER WARRANTIES, EXPRESS OR IMPLIED, INCLUDING BUT NOT LIMITED TO WARRANTY OF MERCHANTABILITY OR WARRANTY OF FITNESS FOR A PARTICULAR PURPOSE.**

Graco's sole obligation and buyer's sole remedy for any breach of warranty shall be as set forth above. The buyer agrees that no other remedy (including, but not limited to, incidental or consequential damages for lost profits, lost sales, injury to person or property, or any other incidental or consequential loss) shall be available. Any action for breach of warranty must be brought within two (2) years of the date of sale.

**GRACO MAKES NO WARRANTY, AND DISCLAIMS ALL IMPLIED WARRANTIES OF MERCHANTABILITY AND FITNESS FOR A PARTICULAR PURPOSE, IN CONNECTION WITH ACCESSORIES, EQUIPMENT, MATERIALS OR COMPONENTS SOLD BUT NOT MANUFACTURED BY GRACO.** These items sold, but not manufactured by Graco (such as electric motors, switches, hose, etc.), are subject to the warranty, if any, of their manufacturer. Graco will provide purchaser with reasonable assistance in making any claim for breach of these warranties.

In no event will Graco be liable for indirect, incidental, special or consequential damages resulting from Graco supplying equipment hereunder, or the furnishing, performance, or use of any products or other goods sold hereto, whether due to a breach of contract, breach of warranty, the negligence of Graco, or otherwise.

## **FOR GRACO CANADA CUSTOMERS**

The Parties acknowledge that they have required that the present document, as well as all documents, notices and legal proceedings entered into, given or instituted pursuant hereto or relating directly or indirectly hereto, be drawn up in English. Les parties reconnaissent avoir convenu que la rédaction du présente document sera en Anglais, ainsi que tous documents, avis et procédures judiciaires exécutés, donnés ou intentés, à la suite de ou en rapport, directement ou indirectement, avec les procédures concernées.

# Graco Information

For the latest information about Graco products, visit [www.graco.com](http://www.graco.com).

**TO PLACE AN ORDER**, contact your Graco distributor or call 1-800-690-2894 to identify the nearest distributor.

*All written and visual data contained in this document reflects the latest product information available at the time of publication.  
Graco reserves the right to make changes at any time without notice.*

*This manual contains English. MM 313888*

**Graco Headquarters:** Minneapolis  
**International Offices:** Belgium, China, Japan, Korea

**GRACO INC. P.O. BOX 1441 MINNEAPOLIS, MN 55440-1441**

Copyright 2008, Graco Inc. is registered to I.S. EN ISO 9001

[www.graco.com](http://www.graco.com)

Revision E - March 2013

Download from [www.Son Manuals.com](http://www.Son Manuals.com). All Manuals Search And Download.

## Free Manuals Download Website

<http://myh66.com>

<http://usermanuals.us>

<http://www.somanuals.com>

<http://www.4manuals.cc>

<http://www.manual-lib.com>

<http://www.404manual.com>

<http://www.luxmanual.com>

<http://aubethermostatmanual.com>

Golf course search by state

<http://golfingnear.com>

Email search by domain

<http://emailbydomain.com>

Auto manuals search

<http://auto.somanuals.com>

TV manuals search

<http://tv.somanuals.com>