



Chariot / Chariot LX

GDRZ48-17KAE, GDRZ48-19KAE, GDRZ52-23KAE, GDRZ52-25KAE, GDRZ52-25KHE,
GDRZ61-25KAE, GDRZ61-25KHE, GDRZ61-25KAE, GDRZ61-25KHE, GDRZ61-26KHE,
GDRZ61-27KHE, GDRZ61-28KHE, GDRZ72-27KHE, GDRZ72-28KHE



OPERATOR'S MANUAL

⚠ WARNING: The Engine Exhaust from this product contains chemicals known to the State of California to cause cancer, birth defects or other reproductive harm.

California Proposition 65 Warning

OMTCU17095 J2

North American Version
Litho in U.S.A.

INTRODUCTION

Using Your Operator's Manual

This manual is an important part of your machine and should remain with the machine when you sell it.

An engine manufacturer's owner's manual has been provided with your machine. This will provide maintenance and troubleshooting information for the engine installed in your machine.

Reading your operator's manual will help you and others avoid personal injury or damage to the machine. Information given in this manual will provide the operator with the safest and most effective use of the machine.

Sections in your operator's manual are placed in a specific order to help you understand all the safety messages and learn the controls so you can operate this machine safely. You can also use this manual to answer any specific operating or servicing questions.

The machine shown in this manual may differ slightly from your machine, but will be similar enough to help you understand our instructions.

RIGHT-HAND and LEFT-HAND sides are determined by facing in the direction the machine will travel when going forward. When you see a broken line (-----), the item referred to is hidden from view.

Special Messages

Your manual contains special messages to bring attention to potential safety concerns, machine damage as well as helpful operating and servicing information. Please read all the information carefully to avoid injury and machine damage.



CAUTION: Avoid injury! This symbol and text highlight potential hazards or death to the operator or bystanders that may occur if the hazards or procedures are ignored.

IMPORTANT: Avoid damage! This text is used to tell the operator of actions or conditions that might result in damage to the machine.

NOTE: General information is given throughout the manual that may help the operator in the operation or service of the machine.

PRODUCT IDENTIFICATION

Record Identification Numbers

Chariot

**GDRZ48-17KAE, GDRZ48-19KAE, GDRZ52-23KAE,
GDRZ52-25KAE, GDRZ52-25KHE,
GDRZ61-25-KAE, GDRZ61-25KHE** Serial No. (010001 -)

Chariot LX

**GDRZ61-25KAE, GDRZ61-25KHE, GDRZ61-26KHE,
GDRZ61-27KHE, GDRZ61-28KHE, GDRZ72-27KHE,
GDRZ72-28KHE** Serial No. (010001 -)

If you need to contact an Authorized Service Center for information on servicing, always provide the product model and serial numbers.

You will need to locate the model and serial numbers for the machine and for the engine of your machine and record the information in the spaces provided.

DATE OF PURCHASE:

DEALER NAME:

DEALER PHONE:

MOWER DECK MODEL NUMBER (C):

MOWER DECK SERIAL NUMBER (C):

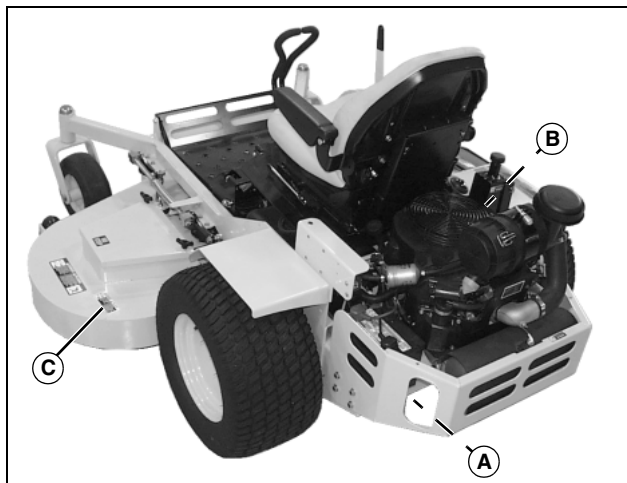

MX15355

MODEL NUMBER (POWER UNIT) (A):

SERIAL NUMBER (POWER UNIT) (A):

ENGINE MODEL NUMBER(B):

ENGINE SERIAL NUMBER (B):

ENGINE SPECIFICATION NUMBER (B):

TABLE OF CONTENTS

Safety	1
Operating	10
Replacement Parts	22
Service Intervals.....	23
Service Lubrication.....	24
Service Engine	26
Service Transmission.....	31
Service Steering & Brakes.....	37
Service Mower.....	41
Service Electrical.....	51
Service Miscellaneous.....	57
Troubleshooting	59
Storage	64
Assembly	65
Specifications	68
Index.....	70
Service Record GD	71

All information, illustrations and specifications in this manual are based on the latest information at the time of publication. The right is reserved to make changes at any time without notice.

COPYRIGHT© 2002

Deere & Co.

John Deere Worldwide Commercial and Consumer Equipment Division

All rights reserved

Previous Editions

COPYRIGHT©

OMTCU17095 J2 - English

SAFETY

Understanding The Machine Safety Labels



Safety-Alert Symbol

The machine safety labels shown in this section are placed in important areas on your machine to draw attention to potential safety hazards.

On your machine safety labels, the words DANGER, WARNING, and CAUTION are used with this safety-alert symbol. DANGER identifies the most serious hazards.

The operator's manual also explains any potential safety hazards whenever necessary in special safety messages that are identified with the word, CAUTION, and the safety-alert symbol.

DANGER

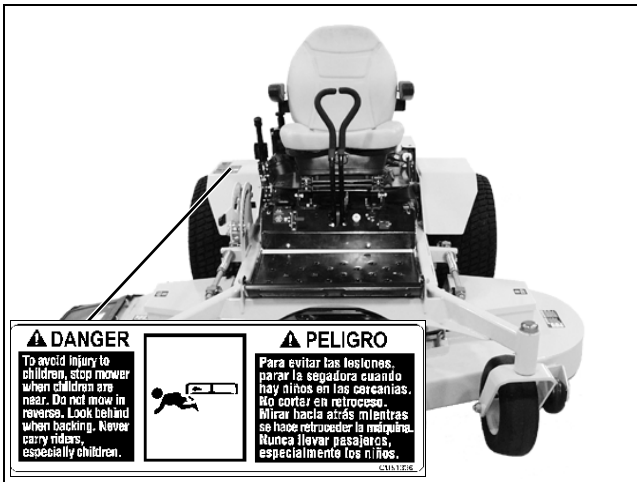

TCU51336, MX15340

To avoid injury to children, stop mower when children are near. Do not mow in reverse. Look behind when backing. Never carry riders, especially children.

DANGER

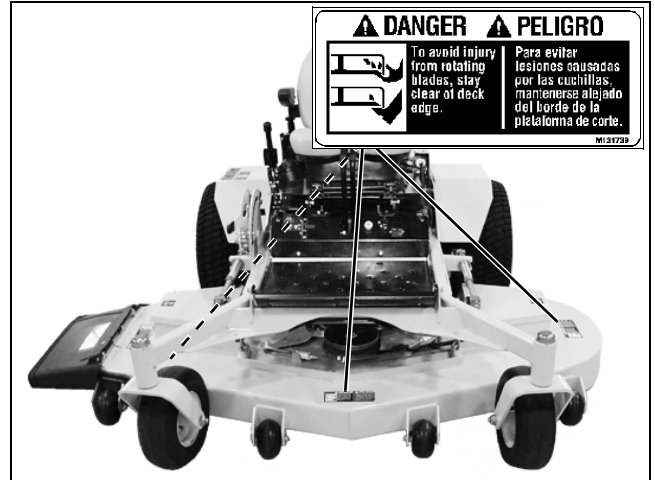

M131739, MX15340

To avoid injury from rotating blades, stay clear of deck edge.

DANGER

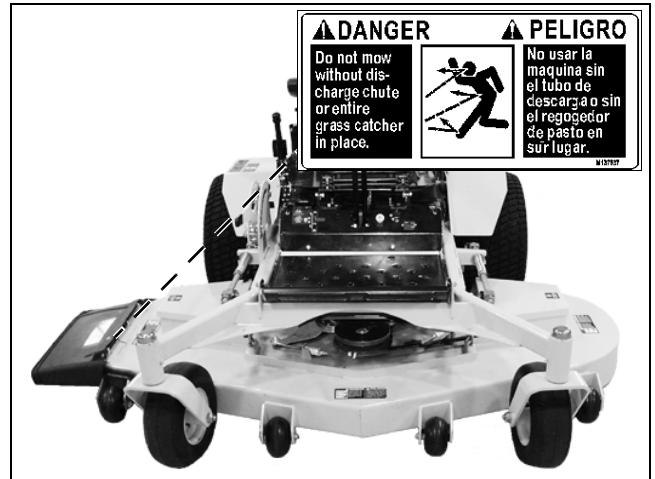

M137637, MX15340

Do not mow without discharge chute or entire grass catcher in place.

SAFETY

DANGER

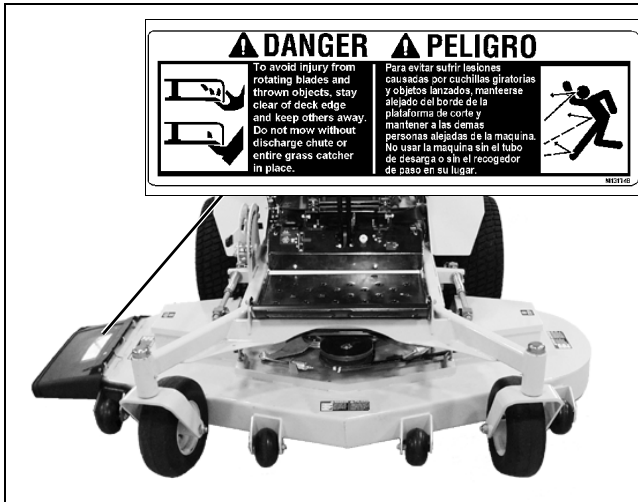

M131748, MX15340

To avoid injury from rotating blades and thrown objects, stay clear of deck edge and keep others away. Do not move without discharge chute or entire grass catcher in place.

DANGER: EXPLOSIVE GASES / POISON: CAUSES SEVERE BURNS

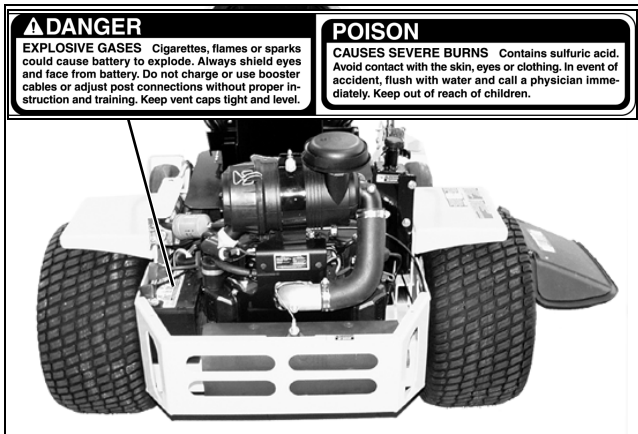

TCU14885, MX15274

- Cigarettes, flames or sparks could cause battery to explode. Always shield eyes and face from battery. Do not charge or use booster cables or adjust post connections without proper instruction and training.
- Contains sulfuric acid. Avoid contact with the skin, eyes or clothing. In event of accident, flush with water and call a physician immediately. Keep out of reach of children.

WARNING

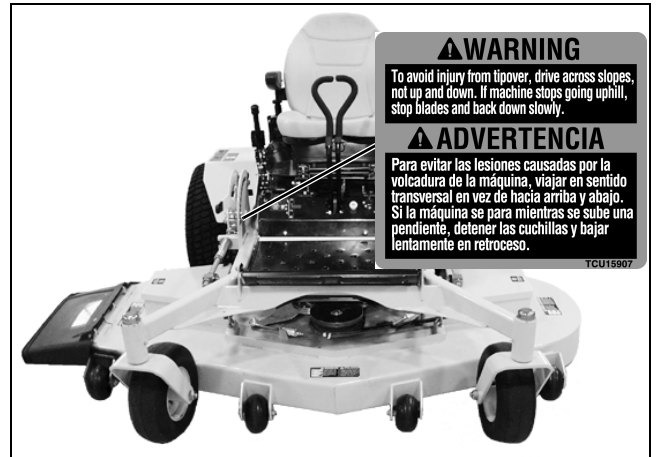

MX15340, TCU15907

To avoid injury from tipover, drive across slopes, not up and down. If machine stops going uphill, stop blades and back down slowly.

WARNING

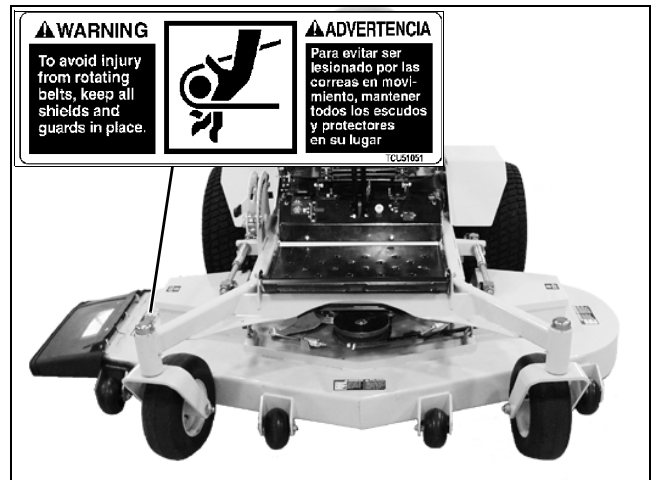

TCU51051, MX15340

To avoid injury from rotating belts, keep all shields and guards in place.

SAFETY

WARNING

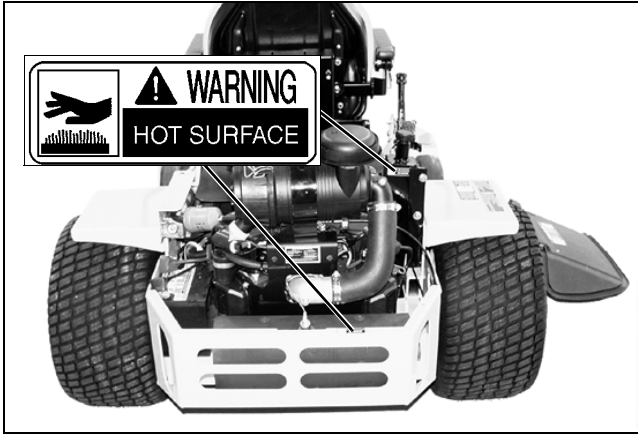

M117554, MX15274

Hot surface

CAUTION: HELP AVOID INJURY

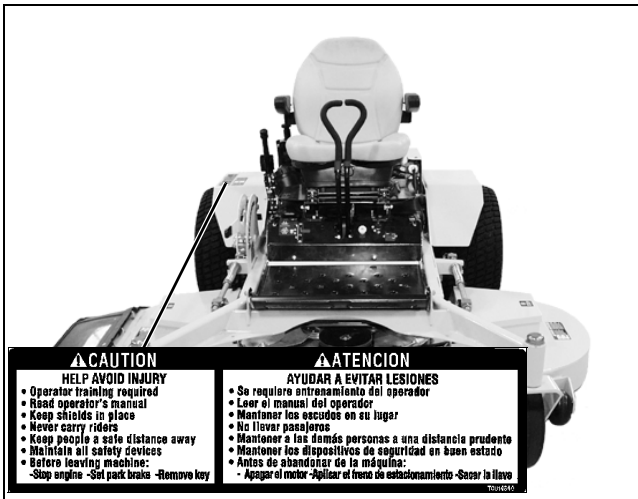

TCU14840, MX15340

- Operator training required
- Read operator's manual
- Keep shields in place
- Never carry riders
- Keep people a safe distance away
- Maintain all safety devices
- Before leaving machine:
 - Stop engine
 - Set park brake
 - Remove key

Emission Control System Certification Label

NOTE: Tampering with emission controls and components by unauthorized personnel may result in severe fines or penalties. Emission controls and components can only be adjusted by EPA and/or CARB authorized service centers. Contact your Great Dane Equipment Retailer concerning emission controls and component questions.

The presence of an emissions label signifies that the engine has been certified with the United States Environmental Protection Agency (EPA) and/or California Air Resources Board (CARB).

The emissions warranty applies only to those engines marketed by Great Dane that have been certified by the EPA and/or CARB; and used in the United States and Canada in off-road mobile equipment.

Emission Compliance Period

If your engine has the emission compliance category listed on the emission control system certification or air index label, this indicates the number of operating hours for which the engine has been certified to meet EPA and/or CARB emission requirements. The following table provides the engine compliance period in hours associated with the category found on the certification label.

Agency	Category	Hours
EPA	C	250
EPA	B	500
EPA	A	1000
CARB	Moderate	125
CARB	Intermediate	250
CARB	Extended	500

Certification

Your product has been tested and evaluated by the manufacturer and conforms with American National Standard B-71.4, "Safety Specifications" for commercial turf care equipment.

Canadian Electromagnetic Compatibility (EMC) Compliance

This spark ignition system complies with Canadian ICES-002.

SAFETY

Operator Training Required

- The owner of the machine is responsible for training the users and mechanics of the machine.
- The owner/user can prevent and is responsible for accidents or injuries occurring to themselves, other people, or property.
- Do not allow operation or service of the machine by untrained adults.
- Do not let children operate the machine. Local regulations may restrict the age of the operator.
- Read the operator's manual and study the safety and operation sections before operating the machine.
- If the operator of the machine cannot read or understand this manual, it is the machine's owner responsibility to explain this material to the operator.
- Operate the machine in an open, unobstructed area under the direction of an experienced operator.
- Learn the use of all controls.
- Operator experience is required to learn the moving, stopping, turning and other operating characteristics of the machine.

Operating Safely

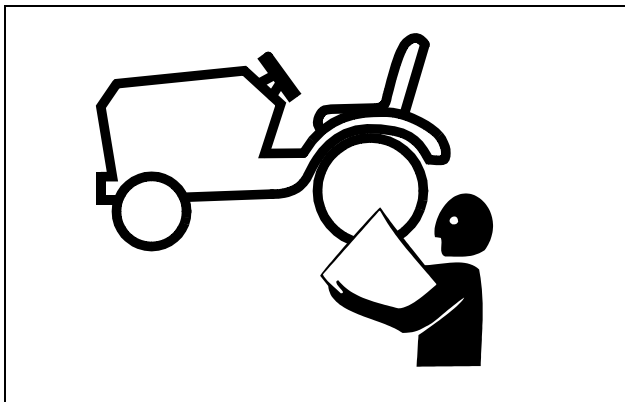

MIF

- Only allow responsible adults, who are familiar with the instructions to operate the machine. Local restrictions may restrict the age of the operator.
- Inspect machine before you operate. Be sure hardware is tight. Repair or replace damaged, badly worn, or missing parts. Replace faulty silencers. Be sure guards and shields are in good condition and fastened in place. Make any necessary adjustments before you operate.
- Before using, always visually inspect to see that the blades, blade bolts and the mower assembly are not worn and damaged. Replace worn and damaged blades and bolts in sets to preserve balance.

- Be sure all drives are in neutral and parking brake is locked before starting engine. Only start engine from the operator's position.
- Do not change the engine governor settings or overspeed the engine. Operating the engine at excessive speed can increase the hazard of personal injury.
- Do not operate mower without discharge chute or entire grass catcher in place. Never operate with the discharge deflector raised, removed, or altered, unless using a grass catcher.
- Check brake action before you operate. Adjust or service brakes as necessary.
- Stop machine if anyone enters the area.
- If you hit an object or if abnormal vibration occurs, stop and inspect the machine. Make repairs before you operate. Keep machine and attachments properly maintained and in good working order.
- Be aware of the mower discharge direction and make sure that no one is in the path of the discharge direction.
- Do not leave machine unattended when it is running.
- Only operate during daylight or with good artificial light.
- Stop the blades rotating before crossing surfaces other than grass.
- Use only accessories and attachments approved by the manufacturer of the machine. Keep safety labels visible when installing accessories and attachments.
- Do not operate machine if you are under the influence of drugs or alcohol.
- Check before each use that operator presence controls are functioning correctly. Test safety systems. Do not operate unless they are functioning correctly.
- Always wear seat belt if machine has a standard ROPS or a folding ROPS in the upright position.
- Never raise mower decks when blades are running.
- Slow down and be careful of traffic when operating near or crossing roadways. Stop blades before crossing roads or sidewalks. Use care when approaching blind corners, shrubs, trees, or other objects that may obscure vision.
- Do not wear radio or music headphones. Safe service and operation require your full attention.
- Disengage drive to attachments when transporting or not in use.
- Reduce the throttle setting during engine run-out and, if the engine is provided with a fuel shut-off valve, turn the fuel off at the conclusion of mowing.
- When machine is left unattended, stored, or parked, lower the mower deck unless a positive mechanical lock is used.

SAFETY

Using a Spark Arrestor

The engine in this machine is not equipped with a spark arrester muffler. It is a violation of California Public Resource Code Section 4442 to use or operate this engine on or near any forest-covered, brush-covered or grass-covered land unless the exhaust system is equipped with a spark arrester meeting any applicable local or state laws. Other states or federal areas may have similar laws.

A spark arrester for your machine may be available from your authorized dealer. An installed spark arrester must be maintained in good working order by the operator.

Checking Mowing Area

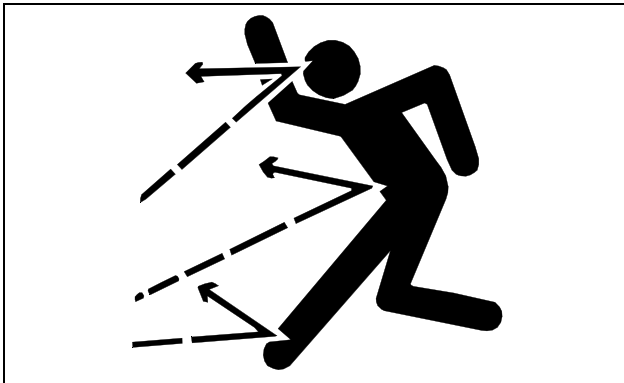

MIF

- Evaluate the terrain to determine what accessories and attachments are needed to properly and safely perform the job.
- Clear mowing area of objects that might be thrown. Keep people and pets out of mowing area.
- Low-hanging branches and similar obstacles can injure the operator or interfere with mowing operation. Before mowing, identify potential obstacles such as low-hanging branches, and trim or remove those obstacles.
- Study mowing area. Set up a safe mowing pattern. Do not mow where traction or stability is doubtful.
- Test drive area with mower lowered but not running. Slow down when you travel over rough ground.

Parking Safely

1. Stop machine on a level surface, not on a slope.
2. Disengage PTO.
3. Lower attachments to the ground.
4. Lock the park brake.
5. Stop the engine.
6. Remove the key.

7. Wait for engine and all moving parts to stop before you leave the operator's seat.

8. Disconnect the negative battery cable or remove the spark plug wire before servicing the machine.

Rotating Blades are Dangerous

HELP PREVENT SERIOUS OR FATAL ACCIDENTS:

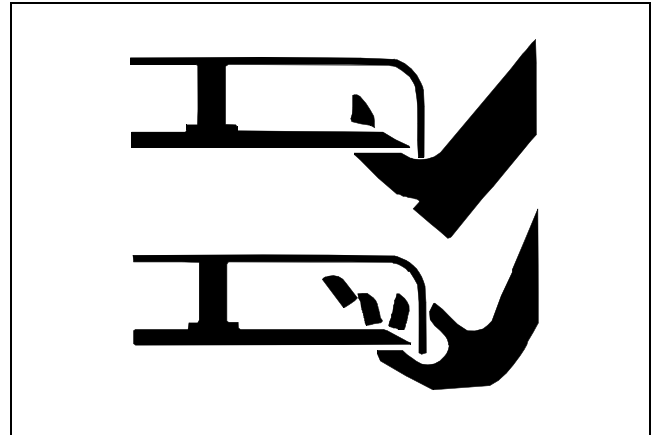

MIF

- Rotating blades can cut off arms and legs.
- Keep hands, feet and clothing away from mower deck when engine is running.
- Be alert at all times, drive forward carefully. People, especially children can move quickly into the mowing area before you know it.
- Before backing up, shut off PTO and look down and behind the machine carefully, especially for children.
- Do not mow in reverse.
- Shut off blades when you are not mowing.
- Park machine safely before inspecting or unplugging mower or bagger for any reason including emptying the catchers or unplugging the chute.

SAFETY

PROTECT CHILDREN:

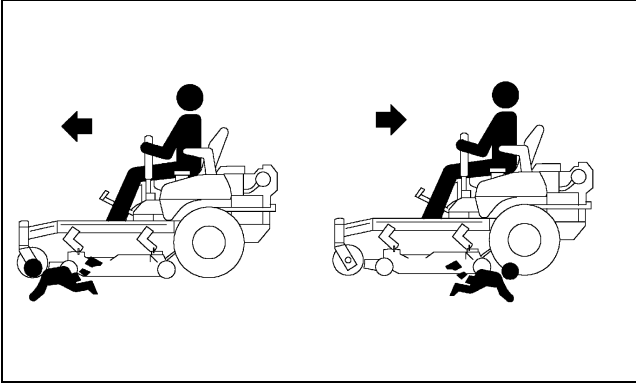

- Never assume that children will remain where you last saw them. Children are attracted to mowing activity, stay alert to the presence of children.
- Keep children indoors when you are mowing. Turn the machine off if a child enters the mowing area.
- Use extra care when you come to blind corners, shrubs, trees, or other objects that may block your vision.
- Do not let children or an untrained person operate the machine.
- Do not carry or let children ride on any attachment or machine even with the blades off. Do not tow children in a cart or trailer.

Avoid Tipping

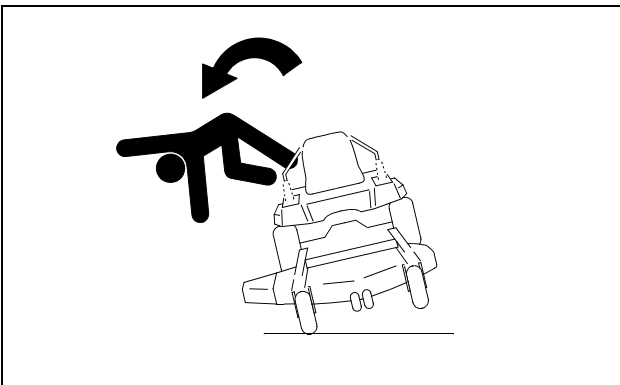

MIF

- Slopes are a major factor related to loss-of-control and tip-over accidents, which can result in severe injury or death.
- Do not drive where machine could slip or tip.
- Stay alert for holes and other hidden hazards in the terrain.
- Keep away from drop-offs, ditches, and embankments.
- Slow down before you make a sharp turn or operate on a slope.

- Transport machine with decks lowered to improve stability.
- Drive machine very slowly and avoid quick stops when attachment is removed.
- Drive across a hill, not up and down. Be careful when you change direction on a slope. If necessary, turn slowly and in the downhill direction.
- Mowing when grass is wet can cause reduced traction and sliding.

Keep Riders Off

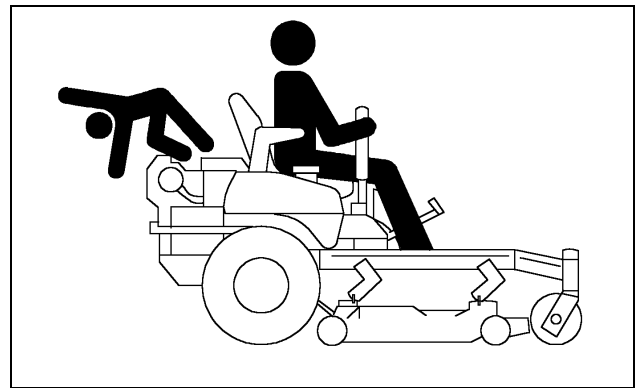

MIF

- Only allow the operator on the machine. Keep riders off.
- Riders on the machine or attachment may be struck by foreign objects or thrown off the machine causing serious injury.
- Riders obstruct the operator's view resulting in the machine being operated in an unsafe manner.

Checking Wheel Bolts

- A serious accident could occur causing serious injury if wheel bolts are not tight.
- Check wheel bolt tightness often during the first 100 hours of operation.
- Wheel hardware must be tightened to specified torque using the proper procedure anytime it is loosened.

SAFETY

Wear Appropriate Clothing

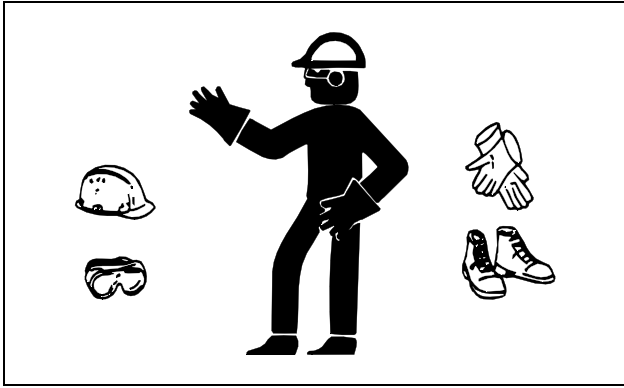

MIF

- Always wear safety goggles, or safety glasses with side shields, and a hard hat when operating the machine.
- Wear close fitting clothing and safety equipment appropriate for the job.
- While mowing, always wear substantial footwear and long trousers. Do not operate the equipment when barefoot or wearing open sandals.
- Wear a suitable protective device such as earplugs. Loud noise can cause impairment or loss of hearing.

Driving Safely on Public Roads

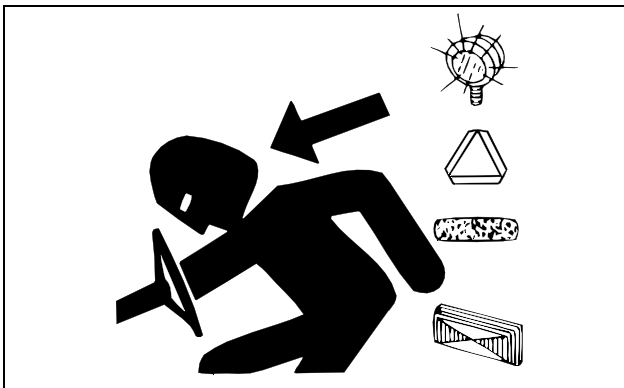

MIF

- Use safety lights and devices. Slow moving machines when driven on public roads are hard to see, especially at night.
- Whenever driving on public roads, use flashing warning lights and turn signals according to local regulations. Extra flashing warning lights may need to be installed.

Practice Safe Maintenance



MIF

- Only qualified, trained adults should service this machine.
- Understand service procedure before doing work. Keep area clean and dry.
- Never lubricate, service, or adjust machine while it is moving. Keep safety devices in place and in working condition. Keep hardware tight.
- Keep hands, feet, clothing, jewelry, and long hair away from any moving parts, to prevent them from getting caught.
- Lower attachments to the ground before servicing machine. Disengage all power and stop the engine. Lock park brake and remove the key. Let machine cool.
- Disconnect battery or remove spark plug wire (for gasoline engines) before making any repairs.
- Before servicing machine, carefully release pressure from any components with stored energy, such as hydraulic components.
- Keep all nuts and bolts tightened, especially blade attachment bolts.
- Securely support any machine elements that must be raised for service work. Use jack stands or lock service latches to support components when needed.
- Never run engine unless park brake is locked.
- Keep all parts in good condition and properly installed. Fix damage immediately. Replace worn or broken parts. Replace all worn or damaged safety and instruction decals.
- Grass catcher components are subject to wear, damage, and deterioration which could expose moving parts or allow objects to be thrown. Check components frequently and replace with manufacturer's recommended parts when necessary.
- To prevent fires, remove any buildup of grease, oil, or debris from the machine, especially the engine compartment.

SAFETY

- Charge batteries in an open, well-ventilated area, away from sparks. Unplug battery charger before connecting or disconnecting from the battery. Wear protective clothing and use insulated tools.
- Do not modify machine or safety devices. Unauthorized modifications may impair its function and safety.

Avoid High-Pressure Fluids



MIF

- Hydraulic hoses and lines can fail due to physical damage, kinks, age, and exposure. Check hoses and lines regularly. Replace damaged hoses and lines.
- Hydraulic fluid connections can loosen due to physical damage and vibration. Check connections regularly. Tighten loose connections.
- Escaping fluid under pressure can penetrate the skin causing serious injury. Avoid the hazard by relieving pressure before disconnecting hydraulic or other lines. Tighten all connections before applying pressure.
- Search for leaks with a piece of cardboard. Protect hands and body from high-pressure fluids.
- If an accident occurs, see a doctor immediately. Any fluid injected into the skin must be surgically removed within a few hours or gangrene may result. Doctors unfamiliar with this type of injury should reference a knowledgeable medical source.

Prevent Fires

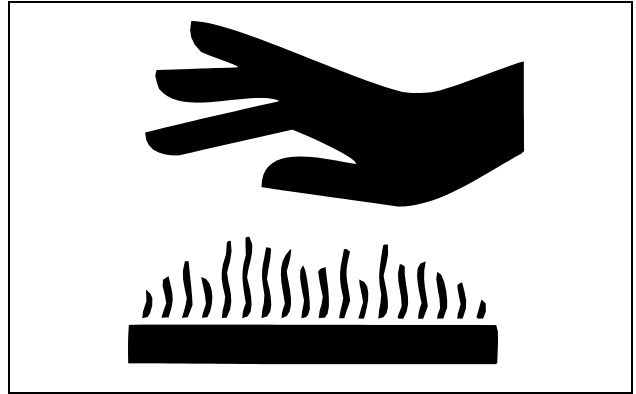

- Remove grass and debris from engine compartment and muffler area, before and after operating machine, especially after mowing or mulching in dry conditions.
- To reduce fire hazard, keep engine and engine compartment free of grass, leaves, or excessive grease.
- Allow engine to cool before storing in any enclosure.
- Never remove fuel cap, or add fuel with engine running or hot. Allow engine to cool for several minutes.
- Never store equipment with fuel in the tank inside a building where fumes may reach an open flame or spark.

Tire Safety



MIF

Explosive separation of a tire and rim parts can cause serious injury or death:

- Do not attempt to mount a tire without the proper equipment and experience to perform the job.
- Always maintain the correct tire pressure. Do not inflate the tires above the recommended pressure. Never weld or heat a wheel and tire assembly. The heat can cause an increase in air pressure resulting in a tire explosion. Welding can structurally weaken or deform the wheel.

SAFETY

- When inflating tires, use a clip-on chuck and extension hose long enough to allow you to stand to one side and NOT in front of or over the tire assembly.
- Check tires for low pressure, cuts, bubbles, damaged rims or missing lug bolts and nuts.

Handling Fuel Safely

Fuel and fuel vapors are highly flammable:

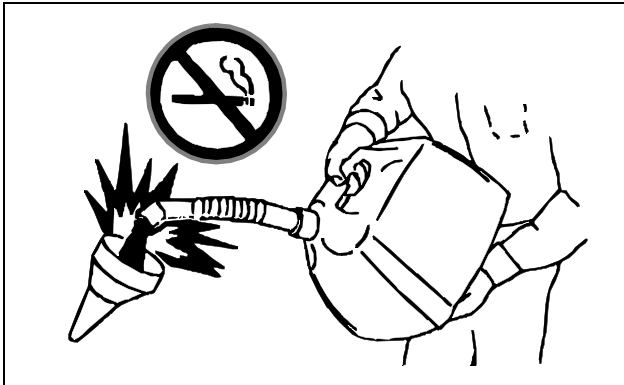

- Do not refuel machine while you smoke, when machine is near an open flame or sparks, or when engine is running. Stop engine and allow to cool before filling.
- Never remove the fuel cap or add fuel with the engine running.
- Never fill fuel tank or drain fuel from a machine in an enclosed area. Fill fuel tank outdoors.
- Prevent fires. Clean up spilled fuel immediately. If fuel is spilled on clothing, change clothing immediately.
- Do not store fuel in container or machine with fuel in tank in a building where fumes may reach an open flame or spark.
- Prevent fire and explosion caused by static electric discharge. Use only non-metal, portable fuel containers approved by the Underwriters Laboratories (UL) or the American Society for Testing and Materials (ASTM). If using a funnel, make sure it is plastic and has no screen or filter.



- Static electric discharge can ignite gasoline vapors in an ungrounded fuel container. Remove the fuel container from the bed of a vehicle or the trunk of a car and place on the ground away from the vehicle before filling. Keep nozzle in contact with container opening while filling. Do not use a nozzle lock-open device.
- When practical, remove equipment from trailers or truck beds and refuel them on the ground. If this is not possible, use a portable, plastic fuel container to refuel equipment on a truck bed or trailer.
- For gasoline engines, do not use gas with methanol. Methanol is harmful to your health and to the environment.

Handling Waste Products and Chemicals

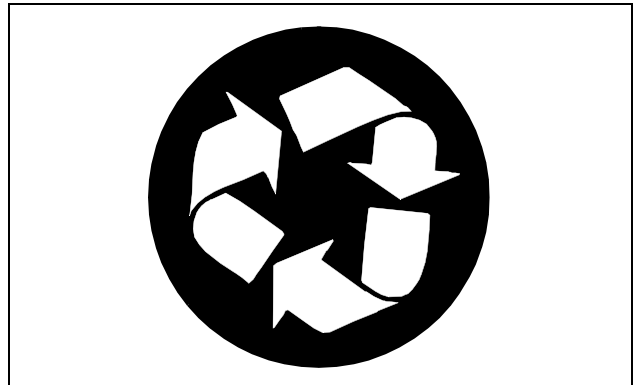

Waste products, such as, used oil, fuel, coolant, brake fluid, and batteries, can harm the environment and people:

- Do not use beverage containers for waste fluids - someone may drink from them.
- See your local Recycling Center or authorized dealer to learn how to recycle or get rid of waste products.
- A Material Safety Data Sheet (MSDS) provides specific details on chemical products: physical and health hazards, safety procedures, and emergency response techniques. The seller of the chemical products used with your machine is responsible for providing the MSDS for that product.

OPERATING

Daily Operating Checklist

- Make sure all necessary guards and shields are safely and securely attached. Check for loose, missing, or damaged parts.
- Remove mower deck belt shields. Clean grass and debris from belt area.
- Remove grass and debris from machine and mower deck.
- Test park brake.
- Test safety systems.
- Inspect battery terminals and hold-downs.
- Inspect for oil leaks.
- Check engine and hydraulic oil levels.
- Inspect all belts for damage or cracking.
- Inspect engine air filter.
- Inspect mower level.
- Adjust cutting height if necessary.
- Inspect wheel bolt torque. Tighten if necessary.
- Check tire air pressure. Check tires for damage or cracking.
- Inspect front caster spindles/wheels.

Operator Station Controls

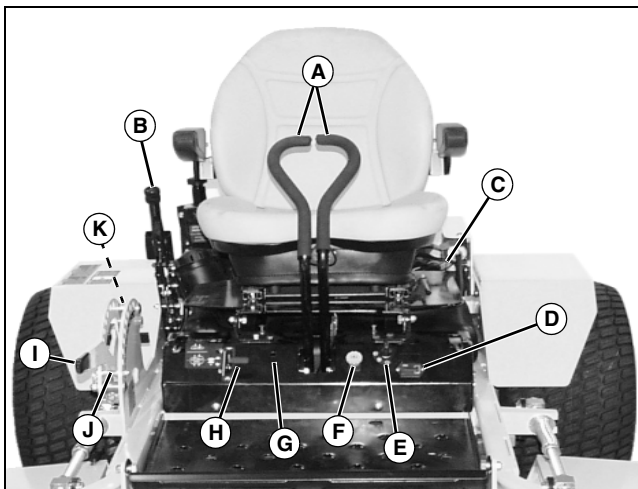

- A - Motion Control Levers
- B - Park Brake Lever
- C - Seat Adjustment Lever
- D - Hourmeter
- E - Ignition Key Switch
- F - PTO Knob
- G - Choke (Carbureted Engines Only)

- H - Throttle Lever
- I - Mower Deck Lift/Lower Lever
- J - Height-of-Cut (HOC) Adjustment Pin
- K - Mower Deck Transport Position Lock Lever

Miscellaneous Controls

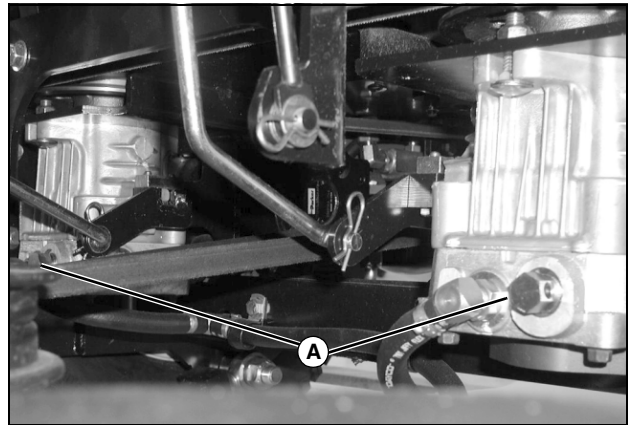

A - Hydraulic Pump Free-Wheel Valves

Testing Safety Systems

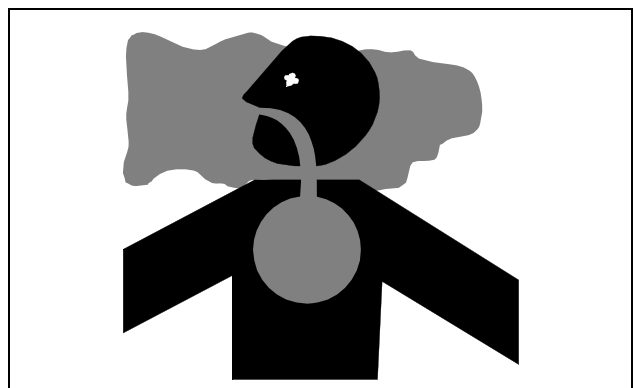

CAUTION: Avoid injury! Engine exhaust fumes contain carbon monoxide and can cause serious illness or death.

Move the machine to an outside area before running the engine.

Do not run an engine in an enclosed area without adequate ventilation.

- **Connect a pipe extension to the engine exhaust pipe to direct the exhaust fumes out of the area.**
- **Allow fresh outside air into the work area to clear the exhaust fumes out.**

OPERATING

The safety systems installed on your machine should be checked before each machine use. Be sure you have read the machine operator manual and are completely familiar with the operation of the machine before performing these safety system checks.

Use the following checkout procedures to check for normal operation of machine.

If there is a malfunction during one of these procedures, do not operate machine. **See your authorized dealer for service.**

Perform these tests in a clear open area. Keep bystanders away.

Testing PTO Switch

1. Sit on the operator seat with the motion control levers in the neutral detent position (standard levers) or neutral lock position (optional "over the lap" levers).
2. Lock the park brake.
3. Pull PTO knob up to engage.
4. Turn key switch to the start position.

Result: The engine must not crank.

Testing Park Brake Switch

1. Sit on the operator seat with the motion control levers in the neutral detent position (standard levers) or neutral lock position (optional "over the lap" levers).
2. Push PTO knob down to disengage.
3. Unlock the park brake.
4. Turn key switch to the start position.

Result: The engine must not crank.

Testing Neutral Start Switch

NOTE: Repeat this test three times, with the motion control levers in the following positions:

- **Right side motion control lever inward.**
- **Left side motion control lever inward.**
- **Both motion control levers inward.**

1. Move motion control lever(s) out of the neutral detent position (standard levers) or neutral lock position (optional "over the lap" levers).
2. Lock the park brake.
3. Push PTO knob down to disengage.
4. Turn key switch to the start position.

Result: The engine must not crank.

Testing Seat Switch

Procedure 1:

1. Sit on the operator seat with the motion control levers in the neutral detent position (standard levers) or neutral lock position (optional "over the lap" levers).
2. Unlock the park brake.
3. Push PTO knob down to disengage.
4. Turn key switch to the start position.
5. Raise slightly off the seat.

Result: The engine must stop.

Procedure 2:

1. Start engine.
2. Lock the park brake.



CAUTION: Avoid injury! Before engaging mower, make sure that area is clear of bystanders, especially children.

3. Pull PTO knob up to engage.
4. Raise slightly off the seat.

Result: The engine must stop.

Testing the Park Brake

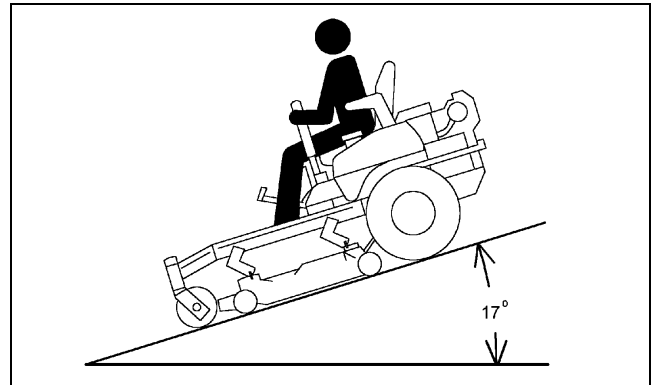

MIF

1. Stop machine on a 17° slope (30% grade). Stop the engine and lock the park brake.

Result: Park brake must hold the machine stationary. (Machine should move no more than 61 cm (24 in.) in one hour.) If machine moves more than that, brakes need to be adjusted. See Adjusting Park Brake in the Service Steering & Brakes section.

OPERATING

Mounting and Dismounting Machine Safely

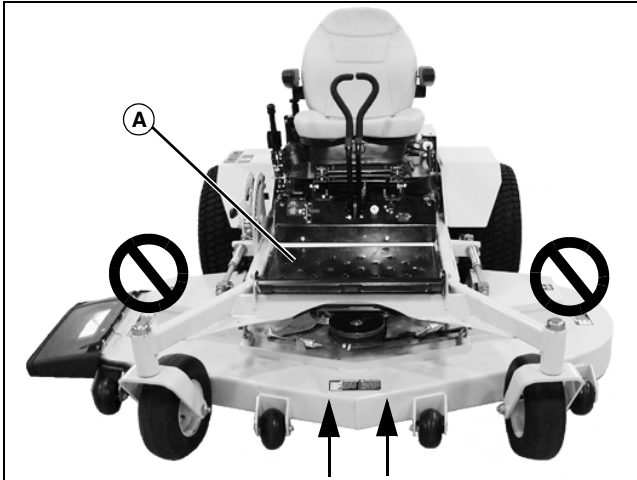

MX15340

Do not step on the mower deck when mounting and dismounting the machine. Mount the machine from the front using the foot plate (A). Park machine safely (see Parking Safely in the Safety section) before dismounting.

Keep the foot plate clean.

Raising and Lowering Operator Seat



CAUTION: Avoid injury! The seat is heavy and can cause injury if it falls. When performing any service function under the operator seat, make sure the seat is tilted forward and rests against the hinge stops.

Raising the Seat:

1. Park machine safely. (See Parking Safely in the Safety section.)
2. Slide seat to full rear position.

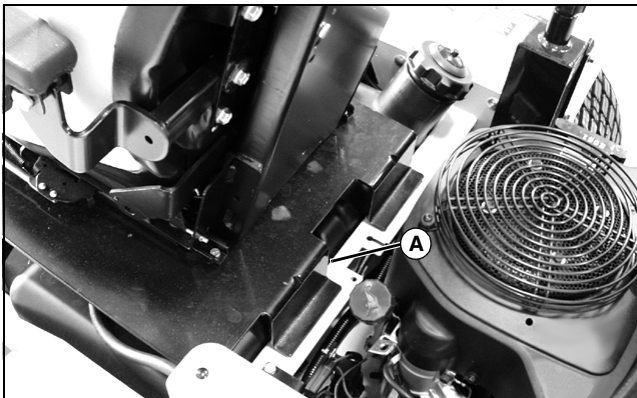

MX15282

3. Lift seat frame (A) and tilt forward until it rests against the hinge stops.

Lowering the Seat:

1. Stand on the side of the machine.
2. Push operator seat back and slowly lower seat frame.

Adjusting Seat

Front-to-Back Adjustment

1. Sit on the operator seat.

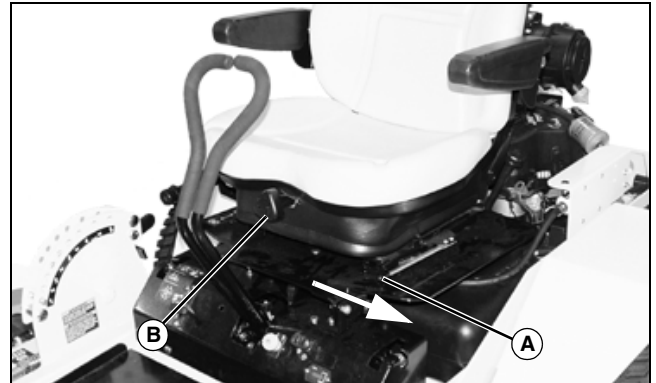

MX15280

Picture Note: Chariot LX suspension seat shown.

2. To adjust the seat front to back, push and hold the seat adjustment lever (A) away from the seat.
3. Slide forward or backward to desired position.
4. Release lever.

Seat Height Adjustment (Chariot LX only)

1. Sit on the operator seat.
2. To lower the seat, turn knob (B) counterclockwise.
3. To raise the seat, turn knob (B) clockwise.

Adjusting Mower Deck Cutting Height



CAUTION: Avoid injury! Before adjusting cutting height, stop engine and lock the park brake.

Cutting height can be adjusted from approximately 25-125 mm (1-5 in.). Each hole adjusts the height-of-cut (HOC) in approximately 12 mm (1/2 in.) increments.

The deck can also be raised and locked in a transport position, to provide maximum ground clearance when moving the machine from one area to another.

1. Park machine safely. (See Parking Safely in the Safety section.)

OPERATING

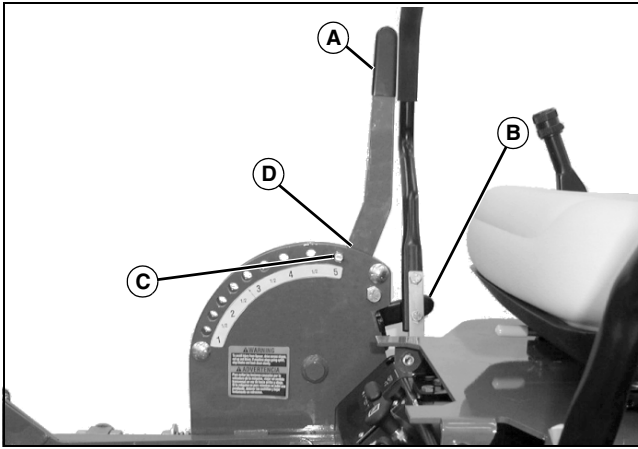

2. Move the mower deck lift lever (A) to the transport position (D).
3. Position the HOC adjustment pin (C) in the proper hole for the desired height-of-cut.
4. Pull back and hold the mower deck lift lever (A) and release the transport position lock lever (B).

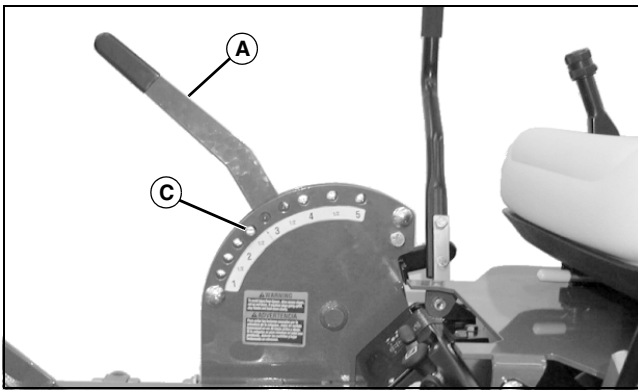

5. Allow the mower deck lift lever (A) to rest against the HOC adjustment pin (C).

Adjusting Mower Deck Anti-Scalp Wheels

CAUTION: Avoid injury! Fingers or loose clothing can get caught in rotating parts. Stop engine and wait for all moving parts to stop before servicing.

NOTE: The flattest cut can be achieved by having all anti-scalp wheels adjusted off the ground. Check anti-scalp wheel adjustments each time the mower deck cutting height is changed.

It is recommended that all anti-scalp wheels be kept off the ground to minimize scuffing.

1. Inflate tires to correct pressure.

2. Adjust mower deck to desired cutting height.

NOTE: The rear anti-scalp wheels are located under the rear of the mower deck.

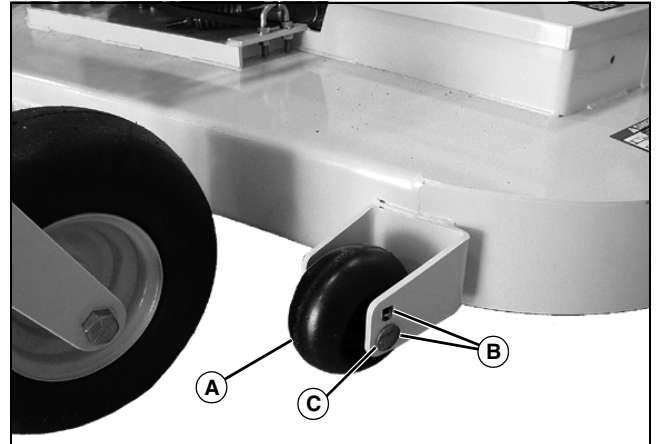

3. Adjust anti-scalp wheel (A) to one of two positions (B).
 - Remove screw (C), nut and washer.
 - Adjust wheel up or down so it is approximately 6-13 mm (1/4-1/2 in.) above mowing surface.
4. Install wheel with attaching hardware.
5. Adjust all wheels to same height.

Using the Park Brake

CAUTION: Avoid injury! Children or bystanders may attempt to move or operate an unattended machine.

Always lock the park brake and remove the key before leaving the machine unattended.

Locking Park Brake:

CAUTION: Avoid injury! If the engine should stop while operating on an incline, the mower will free-wheel. If this should occur, lock the park brake, start the engine, unlock the park brake and resume operation.

OPERATING



MX15275

- Raise and pull rearward park brake lever (A) to the lock park brake.

Unlocking Park Brake:



MX15292

- Lower park brake lever (A) forward to unlock the park brake.

Using the Key Switch

NOTE: Machine will only start if the following conditions exist:

- Park brake is locked.
- PTO is disengaged.
- Motion control levers are in the neutral detent position (standard levers) or neutral lock position (optional "over the lap" levers).

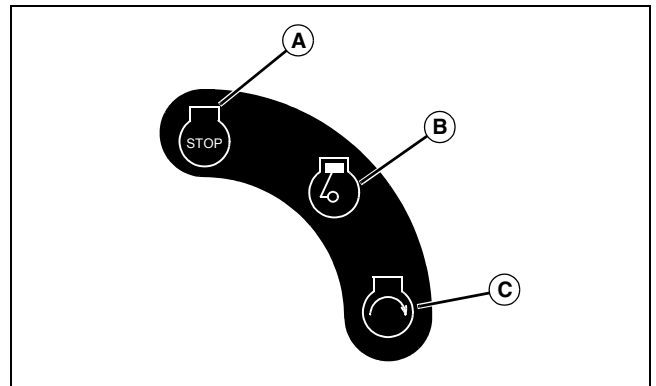

MIF

- To turn ignition off, turn key to the STOP position (A).
- To turn ignition on, turn key to the run position (B).
- To start engine, turn key to the start position (C). Once engine begins to run, release key back to the run position.

Using the PTO

Engage PTO:

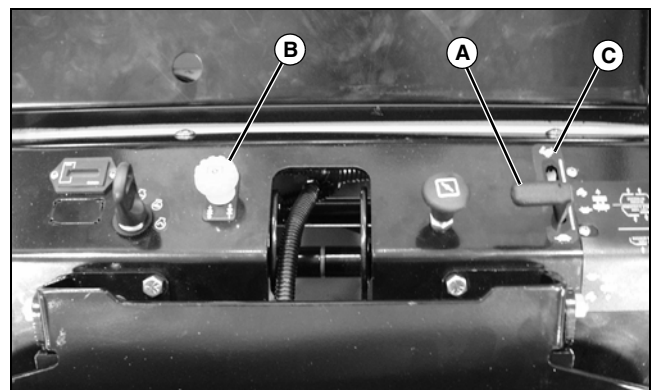

MX15284

1. Move throttle lever (A) to the 1/2- to 3/4-throttle position.
2. Pull PTO knob (B) up to engage mower deck.
3. Move throttle lever (A) forward to the fast detent position (C) for mowing.

Disengage PTO:

- Push PTO knob (B) down.

OPERATING

Using the Throttle Lever

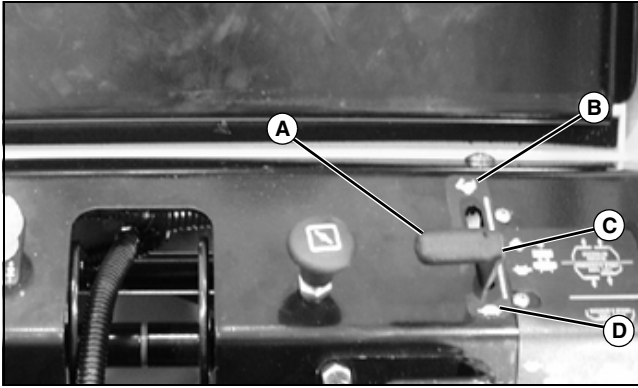

MX15284

- Push throttle lever (A) all the way forward to the full-throttle detent position (B) when mowing.
- Move throttle lever (A) to the 1/2-throttle position (C) when starting and warming the engine.
- Pull throttle lever (A) rearward to the slow position (D) to idle engine. Do not run engine at slow idle any longer than necessary.

Using the Hourmeter

NOTE: The machine is equipped with an electric start. The hourmeter will continue to run with the key switch left in the run position.

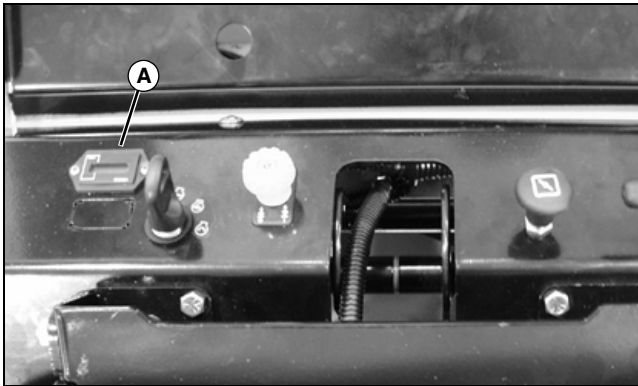

MX15284

- The hourmeter (A) shows the number of hours the machine has run.
- The service interval chart gives necessary service intervals. Use the hourmeter and service interval chart in the Service Intervals section to determine when machine will need service.

See the service interval chart in the engine manufacturer's owners manual supplied with your machine to determine when the engine will need service.

Using the Choke (Carbureted Engines Only)

Engage Choke:

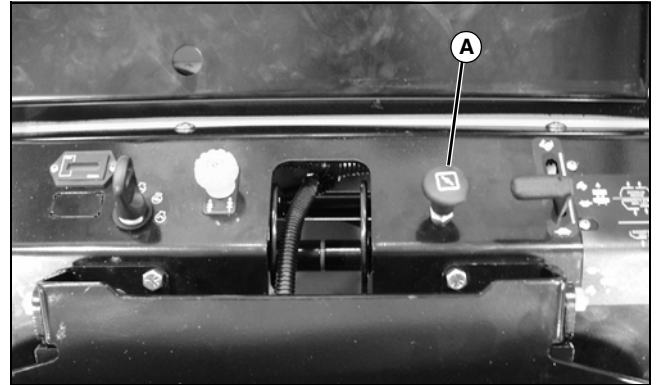

MX15284

- Pull choke knob (A) out.

Disengage Choke:

- Push choke knob (A) in.

Using the Motion Control Levers



CAUTION: Avoid injury! Learn use of the motion control levers and practice at half throttle until becoming proficient and comfortable with the operation of the machine.

Do not move motion control levers from forward to reverse or reverse to forward position rapidly. Sudden direction changes could cause loss of control or damage the machine.

NOTE: Two types of control levers are available - standard "center steer" levers and optional "over the lap" levers. The operation of both styles of levers is the same except as noted.

The functions of the motion control levers are:

- Dual function neutral position.
- Steering.
- Acceleration.
- Braking.

OPERATING

Neutral Detent Position - Standard “Center Steer” Levers

NOTE: When the control levers are in the neutral detent position, the control lever rollers (A) located on each side of the control console will be seated in the notches in the console.

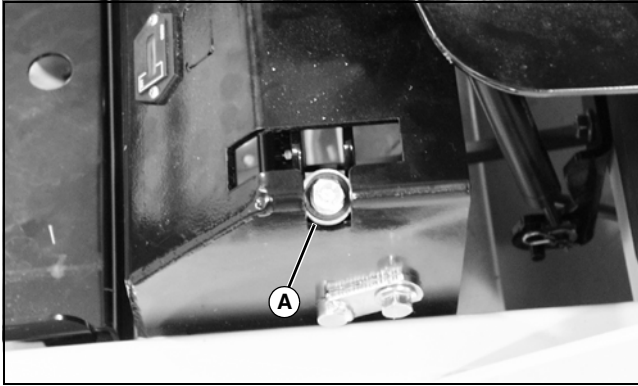

MX15341

- Motion control levers must be in the neutral detent position, the PTO switch disengaged and the park brake locked to start the engine.

Neutral Lock Position - Optional “Over the Lap” Levers

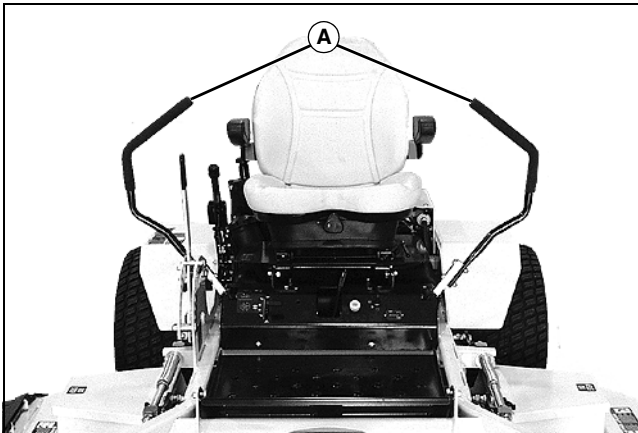

MX15276

Picture Note: Motion control levers (A) shown in the neutral lock position.

- Motion control levers must be in the neutral lock position, the PTO switch disengaged and the park brake locked to start the engine.
- Forward and reverse movement of the motion control levers is prevented when levers are moved to the neutral lock position.
- Operator can exit mower with the engine running when the PTO switch is disengaged, the motion control levers are in the neutral lock position and the park brake is locked.
- Motion control levers must be in the neutral lock position to safely enter and exit the operator seat.

Neutral Position - Optional “Over the Lap” Levers

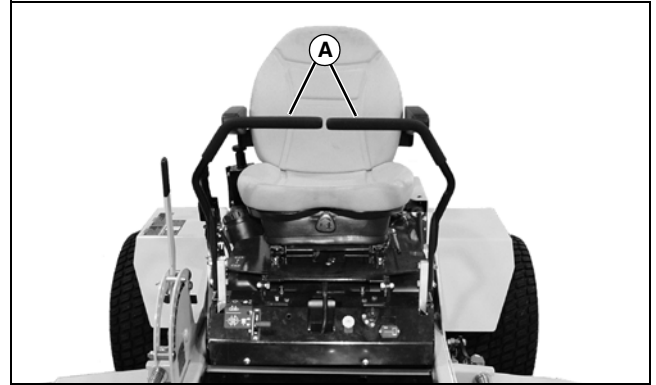

MX15293

Picture Note: Motion control levers (A) shown in the neutral position.

- Machine speed, motion, and direction can be controlled when the engine is running, operator is on the seat and the park brake is unlocked.

Forward and Reverse Motion:



CAUTION: Avoid injury! Children or bystanders may be injured by run over and rotating blades. Before traveling forward or rearward:

- Carefully check the area around the machine.
- Disengage the mower before backing up.

1. Move throttle lever to the full-throttle position.
2. Unlock the park brake.
3. Optional “over the lap” levers: Move both motion control levers from the neutral lock position inward to the neutral position.
4. Push the control levers forward to begin forward motion.
 - The farther forward the control levers are moved, the faster the machine will travel.
 - Forward speed range: 0-14 km/h (0-9 mph).
5. Pull both control levers rearward at the same time to begin reverse motion.
 - Reverse speed range: 0-6 km/h (0-4 mph).
6. To stop motion, move both motion control levers forward or rearward until the machine comes to a stop.

NOTE: The motion control linkages are adjustable. If adjustment is required, see *Checking and Adjusting Motion Control Linkages in the Service Transmission section*.

OPERATING

Forward:

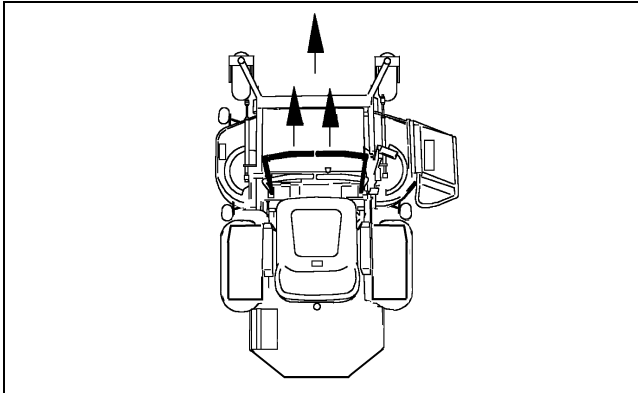

MX13114

- Push both motion control levers forward at the same time.

Reverse:

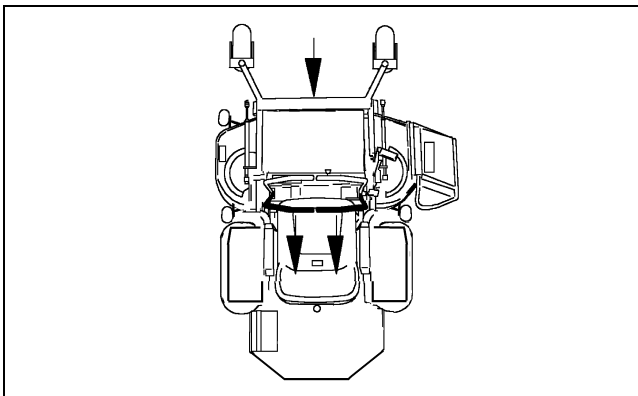

MX13115

- Pull both control levers past center rearward at the same time.

Gentle Left Turn:

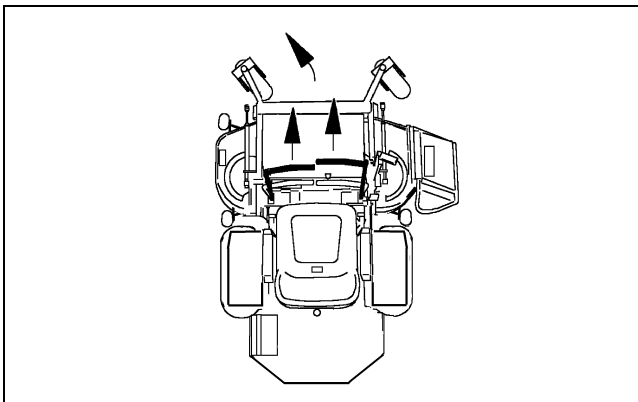

MX13116

- Push right control lever farther forward than the left control lever.

Gentle Right Turn:

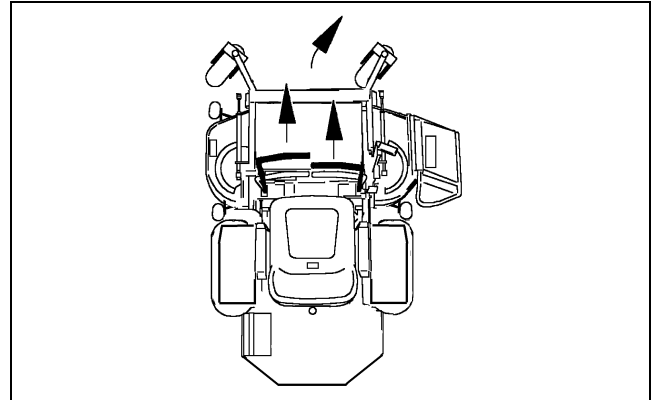

MX13117

- Push left control lever farther forward than the right control lever.

Sharp Left Turn:

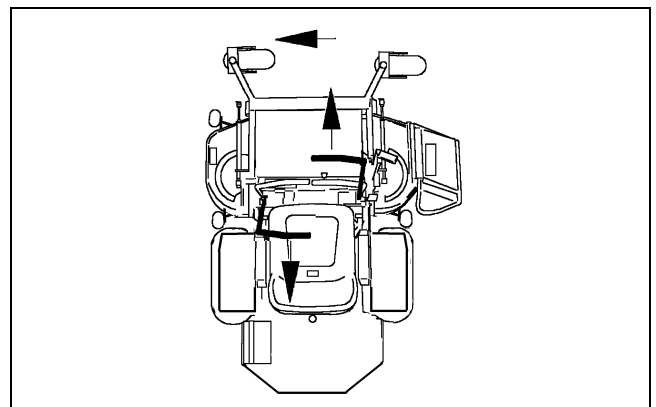

MX13118

- Push right control lever forward and pull left control lever rearward at the same time.

Sharp Right Turn:

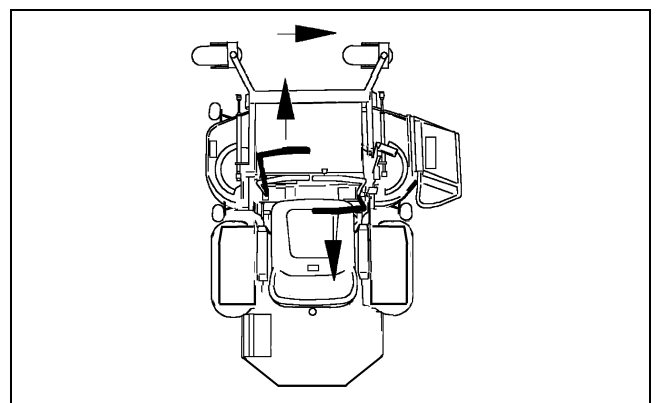

MX13119

- Push left control lever forward and pull right control lever rearward at the same time.

OPERATING

Starting the Engine



CAUTION: Avoid injury! Engine exhaust fumes contain carbon monoxide and can cause serious illness or death.

Move the vehicle to an outside area before running the engine.

Do not run an engine in an enclosed area without adequate ventilation.

- **Connect a pipe extension to the engine exhaust pipe to direct the exhaust fumes out of the area.**
- **Allow fresh outside air into the work area to clear the exhaust fumes out.**

1. Sit on the operator seat.
2. Lock the park brake.
3. Move both motion control levers to the neutral detent position (standard levers) or neutral lock position (optional "over the lap" levers).

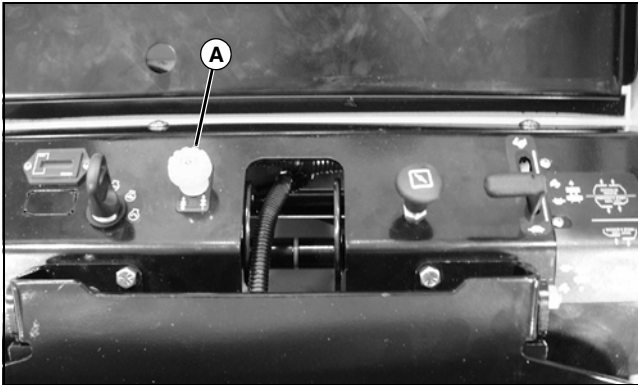

MX15284

4. Push PTO knob (A) down to disengage PTO.
5. Move throttle lever to set engine speed:
 - Cold engine: Set throttle lever at the 1/2- to 3/4-throttle position.
 - Warm/Hot engine: Set throttle lever to the 1/2-throttle position.
6. Carbureted Engines Only: Position choke knob (D):
 - Cold engine: Pull knob up and hold in choke position.
 - Warm/Hot engine: If necessary, pull knob up and hold in choke position.

IMPORTANT: Avoid damage! Starter may be damaged if starter is operated for more than 20 seconds at a time:

- **Wait 2 minutes before trying again if the engine does not start.**

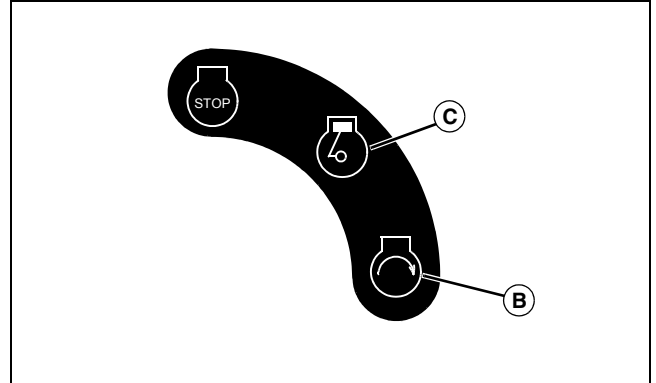

MIF

7. Turn key switch to start position (B).

If the engine does not start, wait 10 seconds.

- Turn key to start position again for no more than 5 seconds.
- Repeat the procedure if necessary.

IMPORTANT: Avoid damage! Unnecessary engine idling may cause engine damage. Excessive idling can cause engine overheating, carbon buildup and poor performance.

8. Release key to run position (C) when engine starts.
9. With engine started:
 - Push choke knob to off position.
 - Move throttle lever to full-throttle position.
 - Unlock the park brake.

OPERATING

Engaging Mower



CAUTION: Avoid injury! Clear mowing area of all bystanders when operating this machine. Thrown objects could cause serious injury or death.

Keep hands and feet away from blades and discharge opening.

Do not mow in reverse unless absolutely necessary.

IMPORTANT: Avoid damage! To help prevent damage to the PTO clutch:

- **Do not engage PTO with throttle in the fast position.**

1. Adjust mower deck to desired cutting height.
2. Start engine.

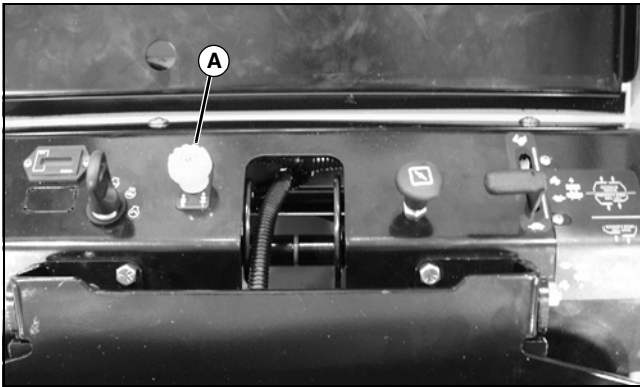

MX15284

3. Move throttle lever to the 1/2- to 3/4-throttle position.
4. Unlock the park brake.
5. Move both motion control levers to the neutral position.

NOTE: In cold weather or with a new machine, it may be necessary to engage the choke at the same time as the PTO knob to prevent the engine from stalling.

6. Pull PTO knob (A) up to engage mower deck.
7. Move throttle lever to full-throttle position.

NOTE: The travel speed and turn rate will vary with the amount that the control levers are moved.

8. Push motion control levers forward slowly. Mow at a safe travel speed.

Stopping the Engine

IMPORTANT: Avoid damage! To help prevent engine backfiring, throttle lever should be set at the 1/4-throttle position and run for 30 seconds prior to stopping the engine.

Do not stop engine when mower is on a slope of more than 30° for an extended period of time. Oil may run through valve train into carburetor and muffler.

1. Move the motion control levers to the neutral detent position (standard levers) or neutral lock position (optional "over the lap" levers).
2. Lock the park brake.
3. Push PTO switch down to disengage.
4. Move throttle lever to 1/4-throttle position and run for 30 seconds, then move throttle to slow position.

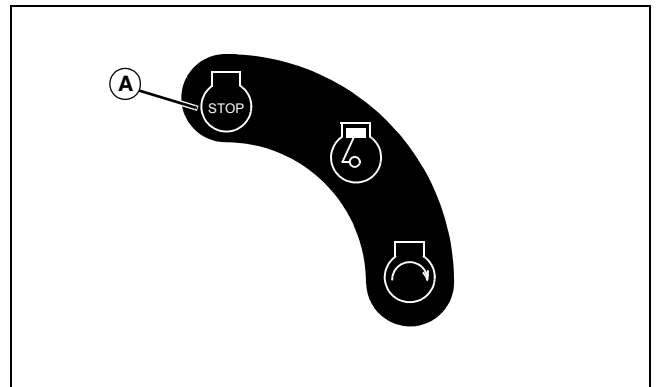

MIF

5. Turn key switch to STOP position (A).



CAUTION: Avoid injury! Children or bystanders may attempt to move or operate an unattended machine.

Always lock the park brake and remove the key before leaving the machine unattended.

6. Remove key.

OPERATING

Using Hydraulic Pump Free-Wheel Valves



CAUTION: Avoid injury! With the free-wheel valves open, the machine will have unrestricted motion.

- The machine may free-wheel out of control if the free-wheel valves are opened with the machine on an incline.
- Park the machine on a level surface before opening the free-wheel valves.

IMPORTANT: Avoid damage! Transmission damage may occur if the machine is moved or towed incorrectly:

- Move unit by hand only.
- Do not use another vehicle to move unit.
- Do not tow unit.

NOTE: The hydraulic pump free-wheel valves must be fully turned clockwise (closed) during normal vehicle operation.

When the machine needs to be moved without starting or running the engine, use the hydraulic pump free-wheel valves:

1. Lock the park brake.

NOTE: The pumps are located under the machine, behind the mower deck.

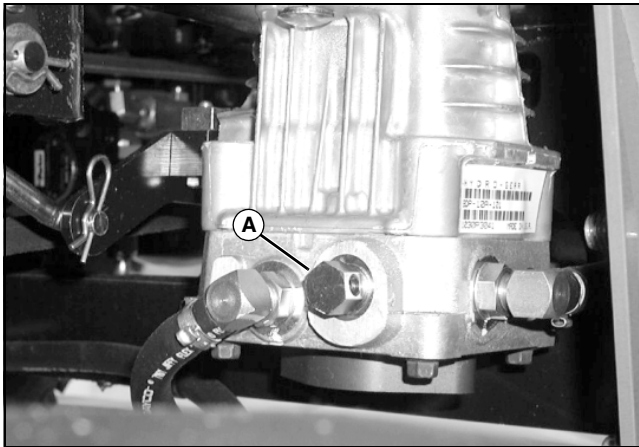

MX13120

Picture Note: Left pump shown.

2. Turn free-wheel valve (A) on both pumps one full turn counterclockwise (open position).
3. Unlock the park brake.
4. Push machine to desired location. Due to hydraulic system drag, machine will move slowly.
5. Turn free-wheel valve (A) on both pumps one full turn

clockwise (closed position). Tighten valve to 9-14 N•m (80-120 lb-in.).

6. Lock the park brake.

Transporting Machine



CAUTION: Avoid injury! Use caution when loading or unloading machine into a trailer or truck.

IMPORTANT: Avoid damage! Transmission damage may occur if the machine is moved or towed incorrectly:

- Move unit by hand only.
- Do not use another vehicle to move unit.
- Do not tow unit.

Use a heavy-duty trailer to transport your machine. Trailer must have signs and lights required by law.

1. Raise the mower deck lift lever to the transport position.
2. Drive machine on trailer.
3. Stop engine and lock the park brake.
4. Remove key.
5. Fasten machine to trailer with heavy-duty straps, chains or cables. Both front and rear straps must be directed down and outward from machine.

Mowing Tips

- Mow grass with throttle lever in the full-throttle position.
- Cut grass when it is dry.
- Keep mower deck and discharge chute clean.
- Mow with sharp blades.
- Properly level mower deck for a smooth cut.
- Mow grass high and often.
- Use a travel speed that fits the conditions:
 - Mow tall or wet grass twice. Cut grass at half desired height; then cut at desired height.
 - Travel slow when mowing tall, thick or wet grass.
 - Avoid damaging grass by slipping or skidding machine drive wheels. Practice smooth control lever movements.
 - When performing sharp turns, do not allow inside machine drive wheel to stop and twist on grass.

OPERATING

Mowing Travel Speeds

Use slow travel speed for:

- Trimming.
- Working in close quarters.
- Mowing tall grass.

Use faster travel speeds for:

- Normal mowing on level ground.

Dismounting to Inspect Mower



CAUTION: Avoid injury! Help prevent serious injury. Keep hands and feet away from blades and the discharge opening.

Do not step on either side of the mower deck when mounting and dismounting the machine. Mount and dismount the machine using the front foot plate.

1. Park machine on a hard, level surface.
2. Push PTO knob down to disengage mower.
3. Move motion control levers to the neutral detent position (standard levers) or neutral lock position (optional “over the lap” levers).
4. Lock the park brake.
5. Stop engine and remove key. Always wait for mower blades to stop turning before leaving operator seat.

Avoid Damage to Plastic and Painted Surfaces

- Do not wipe plastic parts unless rinsed first.
- Insect repellent spray may damage plastic and painted surfaces. Do not spray insect repellent near machine.
- Be careful not to spill fuel on machine. Fuel may damage surface. Wipe up spilled fuel immediately.

REPLACEMENT PARTS

Parts

We recommend Great Dane quality parts available at your Great Dane dealer.

Part numbers may change. Use part numbers listed below when you order. If a number changes, your dealer will have the latest number.

When you order parts, your Great Dane dealer needs your machine model and serial numbers and engine serial number. These are the numbers that you recorded in the Product Identification section of this manual.

Part Numbers

Item	Part Number
Battery	AM124356
Fuel Tank Cap	D18097
Oil Reservoir Cap	GDA10022
Oil Filter (Hydraulic System)	M16053
Traction (Hydro) Drive Belt	D28030
Mower Deck Drive Belt:	
• 1.22 m (48 in.) Deck	TCU16092
• 1.32 m (52 in.) Deck	TCU16093
• 1.55 m (61 in.) Deck	GDU10228
Engine to Deck Drive Belt:	
• 1.83 m (72 in.) Deck	GDU10229
Spindle Drive Belt:	
• 1.83 m (72 in.) Deck	D28028
Mower Blades:	
• 1.22 m (48 in.) Deck	GDU10230
• 1.32 m (52 in.) Deck	GDU10231
• 1.55 m (61 in.) Deck	GDU10232
• 1.83 m (72 in.) Deck	GDU10233

(Part numbers are subject to change without notice. Part numbers may be different outside the U.S.A.)

SERVICE INTERVALS

Servicing Your Machine

IMPORTANT: Avoid damage! Operating in extreme conditions may require more frequent service intervals:

- Engine components may become dirty or plugged when operating in extreme heat, dust or other severe conditions.
- Engine oil and spark plugs may lose efficiency if vehicle is operated constantly at slow or low engine speeds or with frequent short trips.

Please use the following timetables to perform routine maintenance on your machine.

NOTE: The following initial break-in items must be performed and verified to validate the warranty (dealer service invoice accepted).

Break-In (After First 8 Hours of Operation)

- Change engine oil and filter.
- Check drive belt tension.
- Check mower deck drive belt tension (48-, 52- and 61-Inch Mower Deck).
- Check engine-to-deck drive belt tension (72-Inch Mower Deck).
- Check spindle drive belt tension (72-Inch Mower Deck).
- Check transmission neutral adjustment.
- Check wheel nut torque.
- Check and adjust (as needed) park brake.
- Remove debris from the underside of the mower deck.

Every 25 Hours or Weekly (Whichever Comes First)

- Grease mower deck thrust arms (two places).
- Grease spindle bearings (three places).
- Grease traction drive belt tension arm.
- Grease mower deck drive belt tension arm.
- Grease engine-to-deck drive belt tension arm (72-Inch Mower Deck).
- Grease HOC shafts (four places).
- Lubricate spindle drive belt tension arm (72-Inch Mower Deck).
- Lubricate front caster wheels (Chariot LX).
- Lubricate front caster wheel spindles.

Remove debris from the underside of the mower deck.

Every 50 Hours or Weekly (Whichever Comes First)

- Change engine oil and filter. See the engine manufacturer's owner's manual provided with your machine for the complete procedure.
- Grease caster wheel spindle bearings (two places).
- Grease mower deck thrust arms (two places).
- Remove debris from the underside of the mower deck.
- Check drive belt tension.
- Check tire pressure.
- Clean engine air filter.
- Check wheel nut torque.

Every 160 Hours or Monthly (Whichever Comes First)

- Check transmission oil level.
- Lubricate mower deck idler pulley pivots (three places).
- Lubricate seat platform hinges (two places)
- Lubricate pump control arms (five places).
- Lubricate control lever pivot shafts (two places).
- Lubricate throttle cable.
- Lubricate choke control cable (Carbureted Engines Only).

Annually

- Inspect all spindle bearings (6). Replace as needed.
- Inspect all mower deck idler pulleys (3). Replace as needed.
- Remove and inspect caster wheel roller bearings; clean and pack with grease. Replace as needed.
- Remove and inspect caster pivot bearings; clean and pack with grease. Replace as needed.
- Inspect drive belts. Replace as needed. Run-in and adjust tension.
- Clean power unit.
- Change hydraulic oil and filter (annually or 500 hours whichever comes first).
- Check all bolts and nuts; tighten as needed.
- Remove battery. Clean battery and holder.
- Replace spark plugs.

SERVICE LUBRICATION

Grease

IMPORTANT: Avoid damage! If operating outside that temperature range, contact your servicing dealer for a special-use grease.

Use a general all-purpose grease with an NLGI grade No. 2 rating.

Wet or high-speed conditions may require use of a special-use grease. Contact your servicing dealer for information.

Spray Lubricant

Use a general-purpose petroleum-based spray lubricant.

Lubrication Points

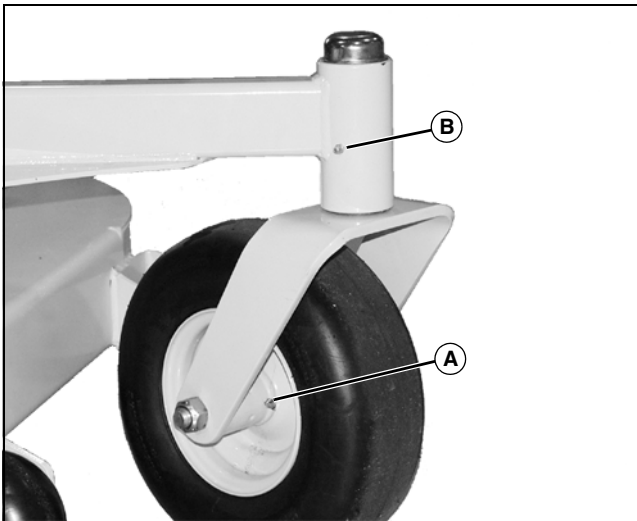

MX15286

- Chariot LX only: Grease caster wheel bearings (A).
- Grease caster wheel spindle bearings (B).

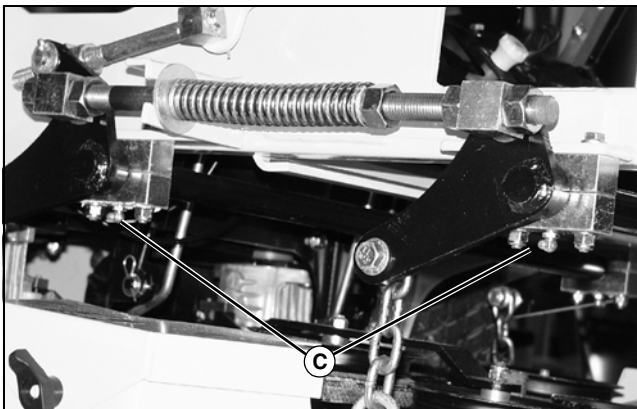

MX15289

- Grease HOC shafts (C) (two points on each side of the machine).

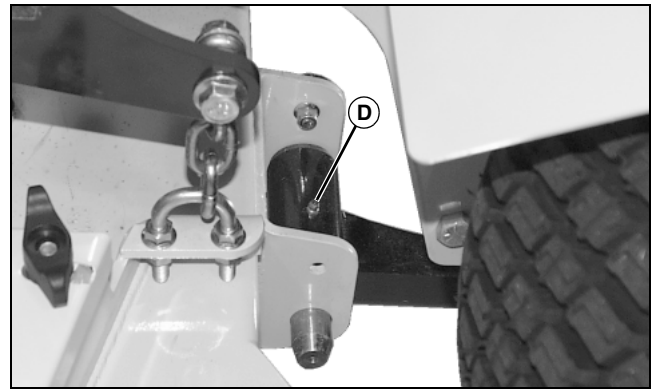

MX15319

- Grease mower deck thrust arms (D), located at the rear of the mower deck.

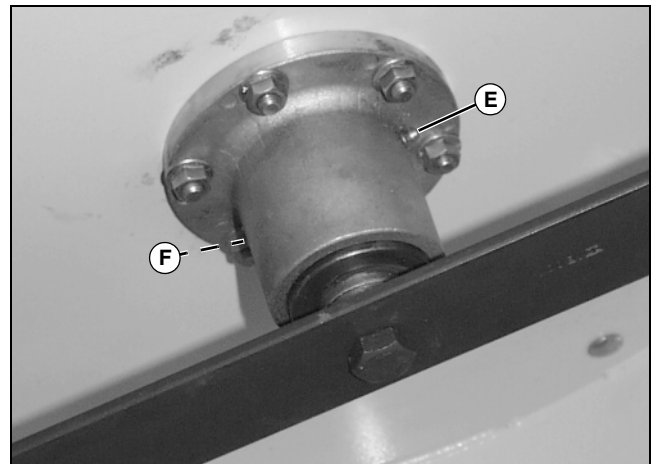

MX15287

- Apply grease to three spindle bearings (E), until grease is expelled from vent (F) on spindle housings.



MX15320

- Grease traction drive belt tension arm pivot (G).

SERVICE LUBRICATION

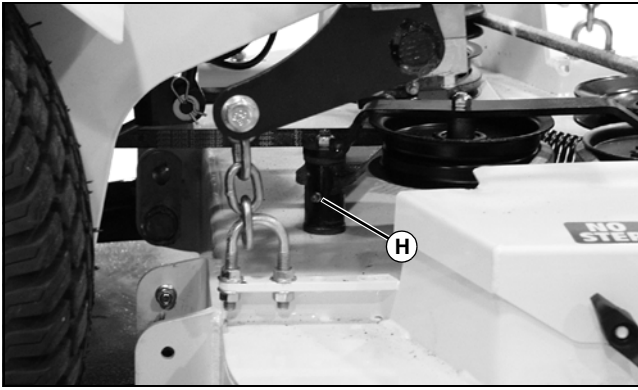

MX15288

- 48-, 51- and 61-Inch Mower Deck: Grease mower deck drive belt tension arm (H).

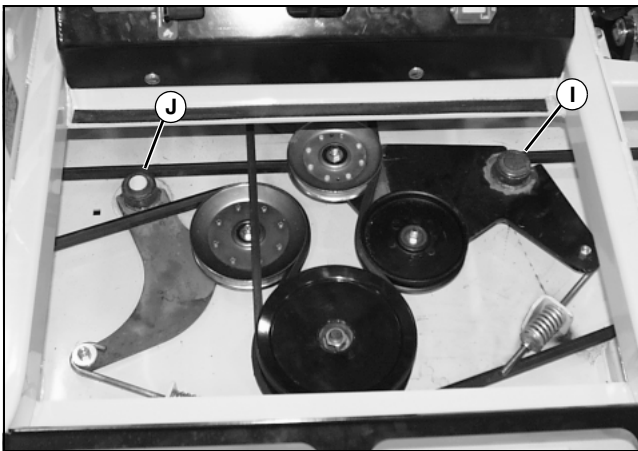

MX15331

- 72-Inch Mower Deck:
 - Grease engine-to-deck drive belt tension arm (I).
 - Apply spray lubricant to the spindle drive belt tension arm (J).

NOTE: Use spray lubricant to lubricate the following items:

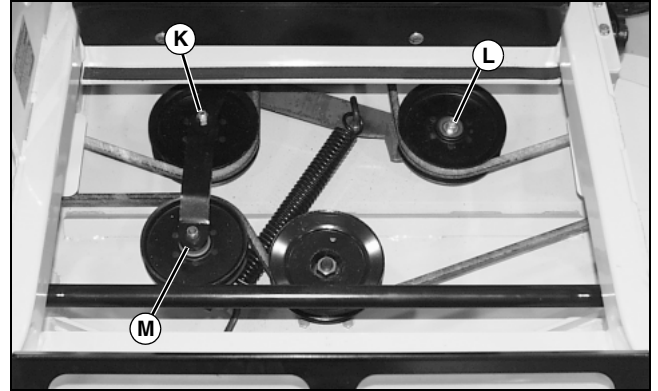

MX15335

Picture Note: 48-, 52- and 61-inch mower decks.

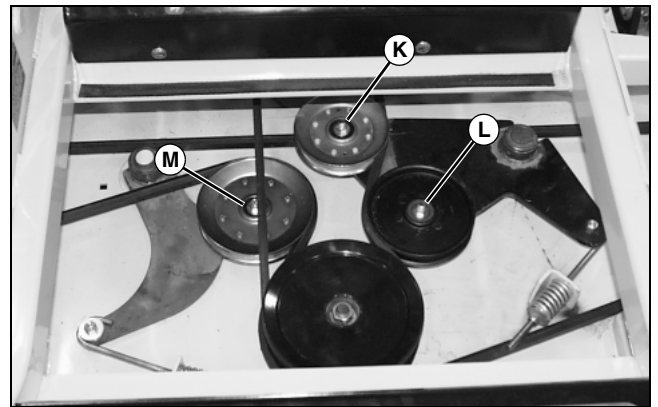

MX15331

Picture Note: 72-inch mower deck.

- Lubricate mower deck idler pulleys (K-M).

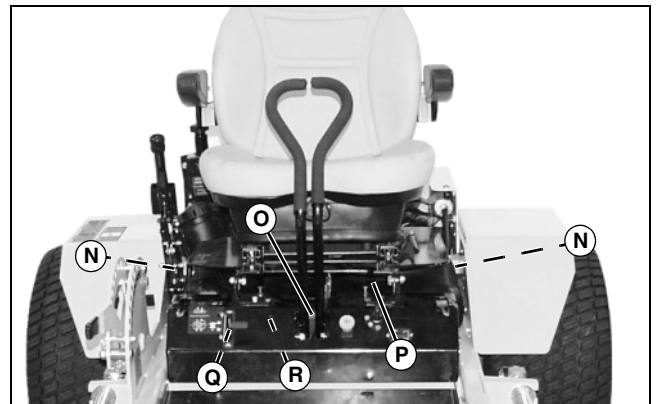

MX15290

- Lubricate hydraulic pump control arms (N).
- Lubricate control lever pivot shaft (O).
- Lubricate seat platform hinges (P).
- Lubricate throttle control cable (Q).
- Carbureted Engines Only: Lubricate choke control cable (R).

SERVICE ENGINE

Engine Warranty Maintenance Statement

Maintenance, repair, or replacement of the emission control devices and systems on this engine, which are being done at the customer's expense, may be performed by any non-road engine repair establishment or individual. Warranty repairs must be performed by an authorized Great Dane servicing dealer.

Avoid Fumes



CAUTION: Avoid injury! Engine exhaust fumes contain carbon monoxide and can cause serious illness or death.

Move the machine to an outside area before running the engine.

Do not run an engine in an enclosed area without adequate ventilation.

- **Connect a pipe extension to the engine exhaust pipe to direct the exhaust fumes out of the area.**
- **Allow fresh outside air into the work area to clear the exhaust fumes out.**

Engine Oil

Use oil viscosity based on the expected air temperature range during the period between oil changes.

Use oil that meets the following specification:

- See the engine manufacturer's owner's manual provided with your machine for the correct specifications.

Checking Engine Oil Level

IMPORTANT: Avoid damage! Failure to check the oil level regularly could lead to serious engine problems if oil level is low:

- **Check oil level before operating.**
- **Check oil level when the engine is cold and not running.**
- **Keep level between the FULL and ADD marks.**
- **Shut off engine before adding oil.**

NOTE: Check oil twice a day if you run engine over 4 hours in a day.

Make sure engine is cool when checking engine oil level.

1. Park machine safely. (See Parking Safely in the Safety section.)
2. Allow engine to cool.
3. Clean area around dipstick to prevent debris from falling into crankcase.
4. Remove dipstick (A). Wipe with a clean cloth.
5. Install dipstick and allow the cap to rest on the end of the tube. Do not tighten the cap.

IMPORTANT: Avoid damage! To prevent extensive engine wear or damage, always maintain the proper engine oil level. Never operate the engine with the oil level below the ADD mark or over the FULL mark.

6. Remove dipstick and check oil level on dipstick. Oil must be between the ADD and FULL marks.
 - If oil is low, add oil to bring oil level no higher than the FULL mark on dipstick.
 - If oil level is above the FULL mark, drain to proper level.
7. Install and tighten dipstick.

Changing Engine Oil and Filter



CAUTION: Avoid injury! Help prevent serious personal injury. Allow the engine, exhaust pipe and muffler to cool before performing this service function.

IMPORTANT: Avoid damage! Change the oil more often if the machine is used in extreme conditions:

- **Extremely dusty conditions.**
- **Frequent slow or low-speed operation.**
- **Frequent short trips.**

1. Run engine to warm oil.
2. Park machine safely. (See Parking Safely in the Safety section).

SERVICE ENGINE

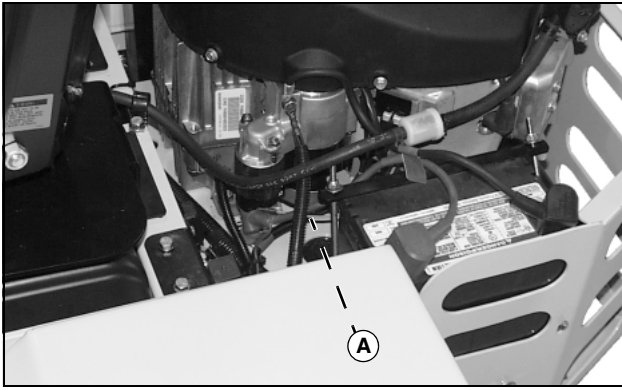

MX15321

3. Put container under drain tube.
4. Open drain valve (A) using a 10 mm socket, 1 ft extension, swivel and 3/8 in. drive ratchet.
5. Allow oil to drain into an oil drain pan.
6. After oil drains, close drain valve.
7. Remove oil filter using an appropriate filter wrench. Turn filter counterclockwise to remove.
8. Apply a film of clean engine oil on gasket of new filter.
9. Install filter. Turn filter clockwise until gasket makes contact with mounting surface. Tighten 1/2 to 3/4 turn after gasket contact.
10. Clean area around the dipstick.
11. Unscrew and remove dipstick.

IMPORTANT: Avoid damage! To prevent extensive engine wear or damage, always maintain the proper engine oil level. Never operate the engine with the oil level below the ADD mark or over the FULL mark.

12. Add approximately 1.4 L (1.5 qt) of oil.
13. Install and tighten dipstick.
14. Start engine and run at slow throttle for approximately two minutes. Check for leaks around filter and drain valve.
15. Stop engine.
16. Check oil level:
 - Remove dipstick. Wipe with a clean cloth.
 - Install dipstick and allow the cap to rest on the end of the tube. Do not tighten the cap.
 - Remove dipstick and check oil level on dipstick. Oil level should be between the ADD and FULL marks. Add oil if needed.
17. Install and tighten dipstick.

MODEL	Oil Capacity With Filter (Dry)
Kawasaki Engines	1.8 L (1.9 qt)
Kohler Engines	2.0 L (2.1 qt)

Checking and Cleaning Air Filter Elements



CAUTION: Avoid injury! Touching hot surfaces can burn skin. The engine and components will be hot if the engine has been running. Allow the engine to cool before servicing.

IMPORTANT: Avoid damage! Dirt and debris can enter the engine through a damaged filter element:

- Do not wash paper element.
- Do not attempt to clean paper element by tapping against another object.
- Do not use pressurized air to clean element.
- Replace element only if it is very dirty, damaged or the seal is cracked.

NOTE: It may be necessary to check the air filter more frequently if operating machine in dusty conditions.

Check and clean air filter elements at the intervals recommended in the Service Intervals section. See the engine manufacturer's owner's manual provided with your machine for the complete procedure.

Cleaning Engine Air Intake Screen and Fan

IMPORTANT: Avoid damage! The engine is air-cooled and requires a large amount of air intake when running. Reduced air intake can cause overheating:

- Keep air intake screen and cooling fins clean.
- Keep covers and screens in place.

Keep air intake screens and engine cooling fins clear of debris to ensure proper cooling. See the engine manufacturer's owner's manual provided with your machine for the complete procedure.

Cleaning Engine Oil Cooler - Kohler Engines

Keep engine oil cooler fins clear of debris to ensure proper cooling. See the engine manufacturer's owner's manual provided with your machine for the complete procedure.

SERVICE ENGINE

Checking Spark Plug



CAUTION: Avoid injury! Touching hot surfaces can burn skin. The engine and components will be hot if the engine has been running. Allow the engine to cool before servicing.

Check spark plugs at the intervals recommended in the Service Intervals section. See the engine manufacturer's owner's manual provided with your machine for the complete procedure.

Adjusting Carburetor - Carbureted Engines

NOTE: Carburetor is calibrated by the engine manufacturer and is not adjustable.

If engine is operated at altitudes above 1829 m (6000 ft), some carburetors may require a special high altitude main jet.

If engine is hard to start or runs rough, see Troubleshooting section of this manual.

Possible engine surging will occur at high throttle with transmission in neutral and mower disengaged. This is a normal condition due to the emission control system.

After performing checks in Troubleshooting section and your engine is still not performing correctly, contact the local engine manufacturer's authorized servicing dealer.

Replacing Fuel Filter - Carbureted Engines



CAUTION: Avoid injury! Fuel vapors are explosive and flammable:

- Do not smoke while handling fuel.
- Keep fuel away from flames or sparks.
- Shut off engine before servicing.
- Cool engine before servicing.
- Work in a well-ventilated area.
- Clean up spilled fuel immediately.

1. Park machine safely. (See Parking Safely in the Safety section.)

2. Allow engine to cool.

3. Place a drain pan under hoses to catch any fuel that may be left in hoses.

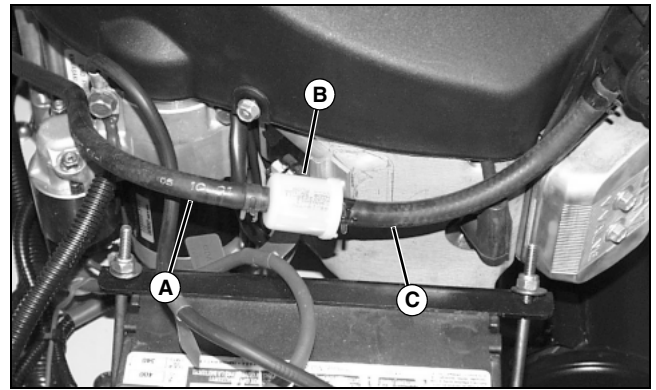

MX15300

Picture Note: Kawasaki engine shown.

4. Disconnect fuel hose (A) from the outlet side of fuel filter (B), and drain gasoline into a properly marked container.
5. Remove fuel filter from inlet fuel hose (C). Discard filter.

IMPORTANT: Avoid damage! When installing a new fuel filter, the filter arrow must be pointing in the direction of fuel flow. Make sure clamps are installed properly.

6. Connect a new fuel filter to hoses. Make sure fuel filter is installed with arrow pointing in direction of fuel flow.

Replacing Fuel Filter - Fuel Injected Engines



CAUTION: Avoid injury! Fuel vapors are explosive and flammable:

- Do not smoke while handling fuel.
- Keep fuel away from flames or sparks.
- Shut off engine before servicing.
- Cool engine before servicing.
- Work in a well-ventilated area.
- Clean up spilled fuel immediately.

1. Park machine safely. (See Parking Safely in the Safety section.)

2. Allow engine to cool.

3. Place a drain pan under hoses to catch any fuel that may be left in hoses.

SERVICE ENGINE



CAUTION: Avoid injury! Fuel system under pressure. Wear personal eye protection when disconnecting fuel hoses to guard against spraying fuel.

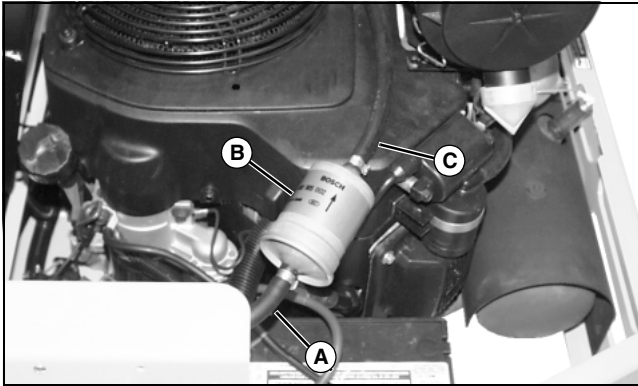

MX15301

4. Disconnect fuel hose (A) from the outlet side of fuel filter (B), and drain gasoline into a properly marked container.
5. Remove fuel filter from inlet fuel hose (C). Discard filter.

IMPORTANT: Avoid damage! When installing a new fuel filter, the filter arrow must be pointing in the direction of fuel flow. Make sure clamps are installed properly.

Use only approved replacement parts: fuel filter (Bosch P/N D28256) and clamps (P/N D18439).

6. Connect a new fuel filter to hoses using new clamps. Make sure fuel filter is installed with arrow pointing in direction of fuel flow.

Priming Fuel Injectors - Fuel Injected Engines

1. Park machine safely. (See Parking Safely in the Safety section.)
2. Allow engine to cool.
3. Fill fuel tank.
4. Turn key switch to run position and leave it in the run position for 15 seconds.
5. Start the engine. If the engine will not start, repeat step 4 two times.

Troubleshooting the Kohler Electronic Fuel Injection System

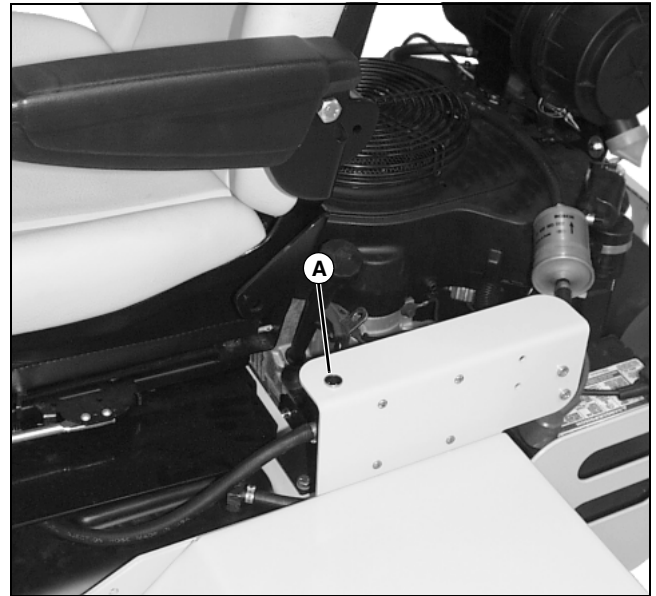

MX15334

Chariot LX models equipped with Kohler engines with the Electronic Fuel Injection (EFI) system will include an MIL (Malfunction Indicator Light) (A). This light will indicate potential problems with the EFI system.

The light will come on when the key switch is moved to the run position, but should go out once the engine has started.

If the light remains on after the engine has started, or if the engine fails to start, there may be a problem with the EFI system or its related electrical system.

The MIL can also be used to access diagnostic codes to aid service. These codes can be accessed only by an authorized Kohler EFI servicing dealer.

When troubleshooting a problem with the Kohler EFI system, basic engine operating problems must be eliminated before faulting the EFI system components. What appears to be an EFI problem could be something as simple as a fuel tank with debris in the bottom or a plugged vent. Be sure the engine is in good mechanical operating condition and other systems are operating properly before attempting to troubleshoot the EFI system.

The EFI system is a 12 VDC negative ground system, designed to operate down to a minimum of 7.0 volts. If the system voltage drops below this level, the operation of voltage sensitive components such as the ECU, fuel pump and injectors will be intermittent or disrupted, causing erratic operation or hard starting. A fully charged, 12-volt battery with a minimum of 250 cold cranking amps is important in maintaining steady and reliable system operation. Battery condition and state of charge should always be checked first when troubleshooting an operational problem.

SERVICE ENGINE

Keep in mind that EFI-related problems are more often caused by the wiring harness or connections than by the EFI components. Even small amounts of corrosion or oxidation on the terminals can interfere with the milliamperage currents used in system operation. Cleaning the connectors and grounds will solve problems in many cases. In an emergency situation, simply disconnecting and reconnecting the connectors may clean up the contacts enough to restore operation, at least temporarily.

IMPORTANT: Avoid damage! When performing voltage or continuity tests, avoid putting excessive pressure on or against the connector pins. Flat probes are recommended for testing to avoid spreading or bending the terminals.

If the MIL indicates a problem with the EFI system, first disconnect the Electronic Control Unit (ECU) connector and test for continuity between the component connector terminals and the corresponding terminals in the ECU connector using an ohmmeter. Little or no resistance should be measured, indicating that the circuit is good.

If the condition cannot be corrected by checking the electrical system and connections, the EFI system must be serviced by an authorized Kohler EFI servicing dealer.

SERVICE TRANSMISSION

Hydraulic Oil

Use only 5W-50 or 15W-50 all synthetic oil.

Checking Hydraulic Oil Level

IMPORTANT: Avoid damage! Check oil level in reservoir tank when oil is cold.

Do not overfill oil reservoir tank. Oil will expand during operation and could overflow.

1. Park machine safely. (See Parking Safely in the Safety section.)



MX15294

2. Unscrew and remove hydraulic reservoir cap/dipstick (A) from hydraulic oil reservoir.

3. Wipe dipstick with a clean cloth.

4. Install dipstick and allow the cap to rest on the end of the tube. Do not tighten the cap.

5. Remove dipstick and check oil level. Oil level should be at top mark on dipstick.

6. If necessary, add oil through oil reservoir filler neck.

7. Install cap on filler neck.

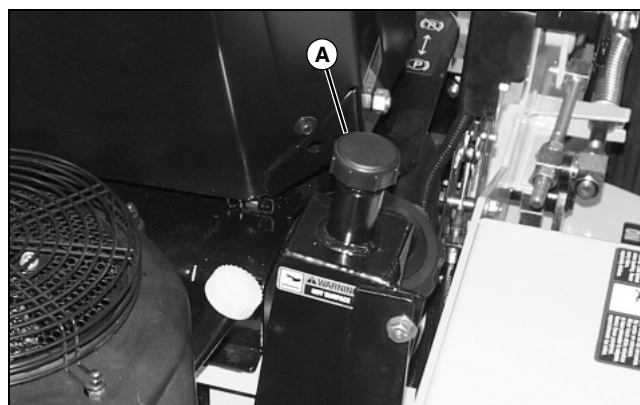

MX15294

4. Remove cap (A) from oil reservoir tank filler neck.

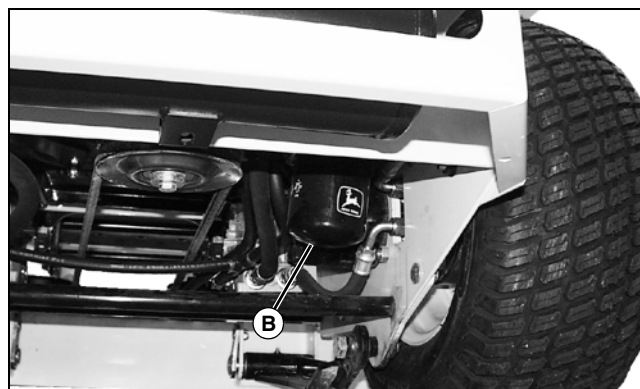

MX15312

5. Turn hydraulic oil filter (B) counterclockwise to remove.

6. Allow hydraulic oil to drain into a drain pan with at least a 3.8 L (1.0 gal) capacity.

7. Apply a film of clean oil on gasket of new filter.

8. Install filter. Turn filter clockwise until gasket makes contact with mounting surface. Tighten 1/2 to 3/4 turn after gasket contact.

NOTE: Reservoir capacity is approximately 1.9 L (2.0 qt). Total system capacity is approximately 3.5 L (3.75 qt).

9. Fill oil reservoir with approximately 1.9 L (2.0 qt) of oil.

10. Install reservoir cap.

Changing Hydraulic Oil and Filter

IMPORTANT: Avoid damage! Contamination of hydraulic fluid could cause transmission damage or failure. Do not open oil reservoir cap unless absolutely necessary.

Severe or unusual conditions may require a more frequent service interval.

1. Park machine safely. (See Parking Safely in the Safety section.)

2. Allow engine and hydraulic oil reservoir to cool.

3. Clean area around reservoir filler cap, and remove filler cap from reservoir.

SERVICE TRANSMISSION



CAUTION: Avoid injury! Engine exhaust fumes contain carbon monoxide and can cause serious illness or death.

Move the machine to an outside area before running the engine.

Do not run an engine in an enclosed area without adequate ventilation.

- Connect a pipe extension to the engine exhaust pipe to direct the exhaust fumes out of the area.
- Allow fresh outside air into the work area to clear the exhaust fumes out.

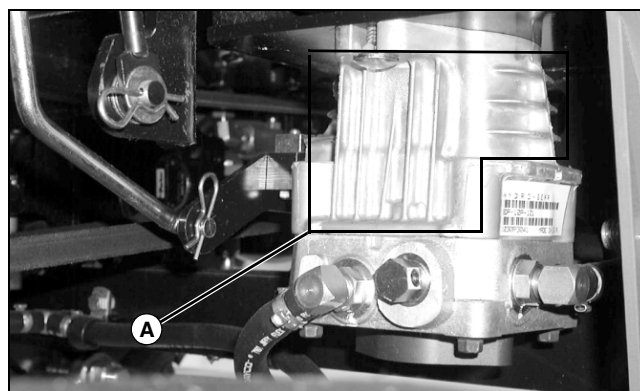

MX13120

2. Clean hydraulic oil cooler fins (A) on each hydraulic pump with a rag, brush, or compressed air.

11. Start engine.

12. Move throttle lever to 3/4-throttle position.

13. Unlock the park brake.



CAUTION: Avoid injury! Help prevent serious bodily injury. Remain alert to other people and the surroundings when operating the machine.

14. Run engine in full forward position for several minutes and then cycle motion control levers forward and rearward several times. Check for leaks around filter.

15. Stop engine. Check oil level. Add oil as necessary.

Cleaning Hydraulic Pump Cooling Fins



CAUTION: Avoid injury! Help prevent injury from foreign particles when using compressed air for cleaning purposes, clear area of bystanders, and wear personal eye protection to guard against flying debris.

IMPORTANT: Avoid damage! To ensure proper cooling, keep the cooling fins clean at all times. Operating the machine with obstructed cooling fins could cause damage due to overheating.

1. Park machine safely. (See Parking Safely in the Safety section.)

Removing and Installing Traction Drive Belt

1. Park machine safely. (See Parking Safely in the Safety section.)

2. Remove mower deck drive belt (48-, 52 and 61-inch mower decks), or engine-to-deck drive belt (72-inch mower decks).

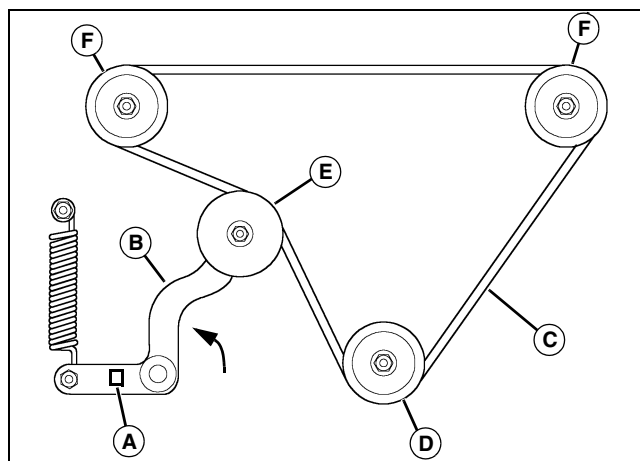

MX9232

Picture Note: Drive belt routing as viewed from top of machine.

A - 1/2 in. Square Opening

B - Tension Arm

C - Traction Drive Belt

D - Engine Drive Sheave

E - Tension Idler Sheave

F - Hydraulic Pump Sheave

3. Using a 1/2 in. drive breaker bar and extension, insert end of extension in 1/2 in. drive square opening (A) in tension arm (B) and carefully move tension arm (B) counter-clockwise to release belt tension.

4. Remove drive belt (C).

SERVICE TRANSMISSION

5. Install new drive belt.
6. Install mower deck drive belt as shown.

Checking and Adjusting Motion Control Linkages



CAUTION: Avoid injury! Do not attempt this adjustment unless you are a qualified and properly trained technician.

Check Neutral Creep



CAUTION: Avoid injury! Engine exhaust fumes can cause sickness or death:

- If it is necessary to run an engine in an enclosed area, use an exhaust pipe extension to remove the fumes.
- Always try to work in a well-ventilated area.

NOTE: Check and adjust motion control linkages with the machine parked on a hard, level surface.

1. Start engine.
2. Set throttle lever to full-throttle position.
3. Unlock the park brake.
4. If the rear drive wheels begin to creep, an adjustment is required.

Neutral Creep Adjustment

1. Stop engine and lock the park brake.
2. Move both motion control levers to neutral detent position (standard levers) or neutral lock position (optional "over the lap" levers).
3. Raise the rear wheels off the ground and securely support the rear of the machine.

NOTE: When tilting the seat forward, do not tilt the seat so far forward that it moves the motion control levers out of the neutral detent position.

4. Tilt operator seat forward and support the seat frame.

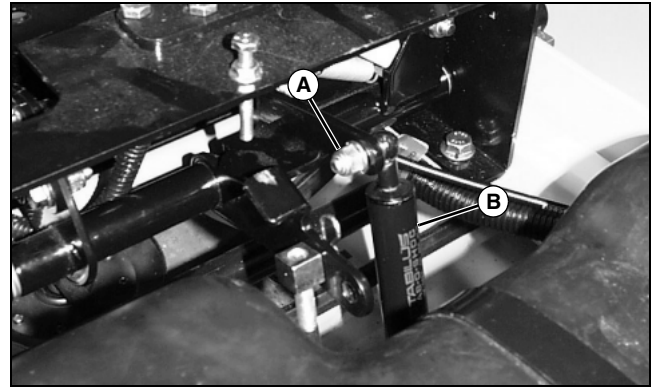

MX15350

5. Loosen nut (A), and move the dampener (B) in adjusting slot backward or forward to stop machine creep.

- If machine creeps forward, slide dampener to the rear of the adjusting slot. Tighten nut.
- If machine creeps backward, slide dampener to the front of the adjusting slot. Tighten nut.

6. Check for creep, and if the machine still creeps, continue with the next step.

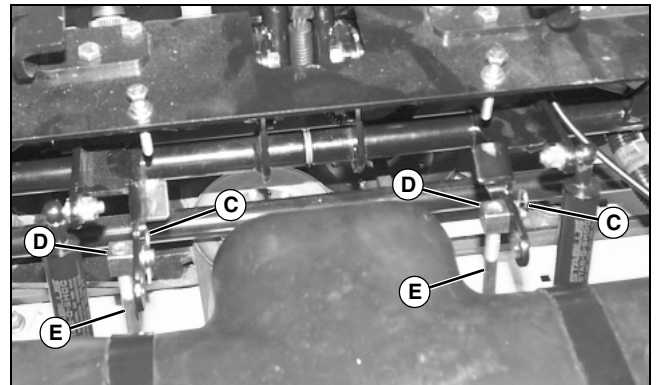

MX15351

7. Remove pin (C) and disconnect swivel (D) from each traction control rod (E), and rotate the swivel.

8. Rotate swivel (D) to adjust:

- To stop forward creep, rotate each swivel (D) counterclockwise one rotation.
- To stop rearward creep, rotate each swivel (D) clockwise one rotation.

9. Connect swivel to traction control rod.
10. Repeat as needed to stop machine creep.
11. Lower seat.
12. Lower the rear of the machine to the ground.
13. Check maximum speed drift.

Check Maximum Speed Drift

1. Check neutral creep, and adjust as needed.

SERVICE TRANSMISSION

2. Sit on the seat, and start the engine.
3. Operate machine to bring the hydraulic oil to normal operating temperature.
4. Move the machine in a level, wide-open area, such as an empty parking lot.
5. Run the engine at full throttle.
6. Move and hold both control levers to the full forward position. Observe the machine travel. If the machine does not travel in a straight line, adjustment is required. Note the direction the machine moves.

Maximum Speed Drift Adjustment

1. Park machine safely. (See Parking Safely in the Safety section.)
2. Tilt operator seat forward and support the seat frame.

NOTE: If the machine travels to the left, adjust the right speed drift screw (A). If the machine travels to the right, adjust the left speed drift screw (B).

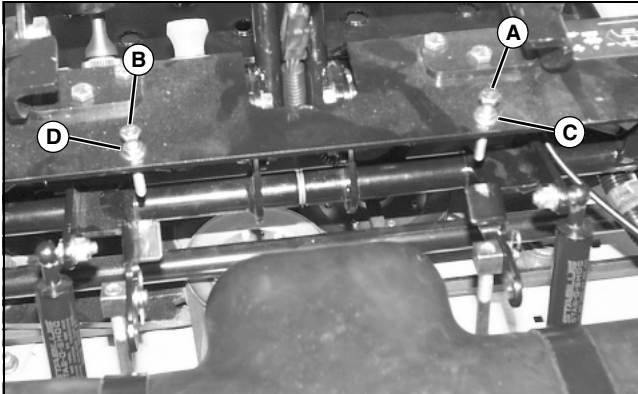

MX15351

3. Adjust the appropriate speed drift screw (A or B) as follows:
 - a. Loosen jam nut (C or D).
 - b. Adjust the screw (A or B) one turn clockwise.
 - c. Tighten the jam nut (C or D).
4. Lower the seat platform.
5. Perform Check Maximum Speed Drift procedure to check adjustment. Repeat the adjustment procedure as needed.

SERVICE TRANSMISSION

Hydraulic System Hose Routing

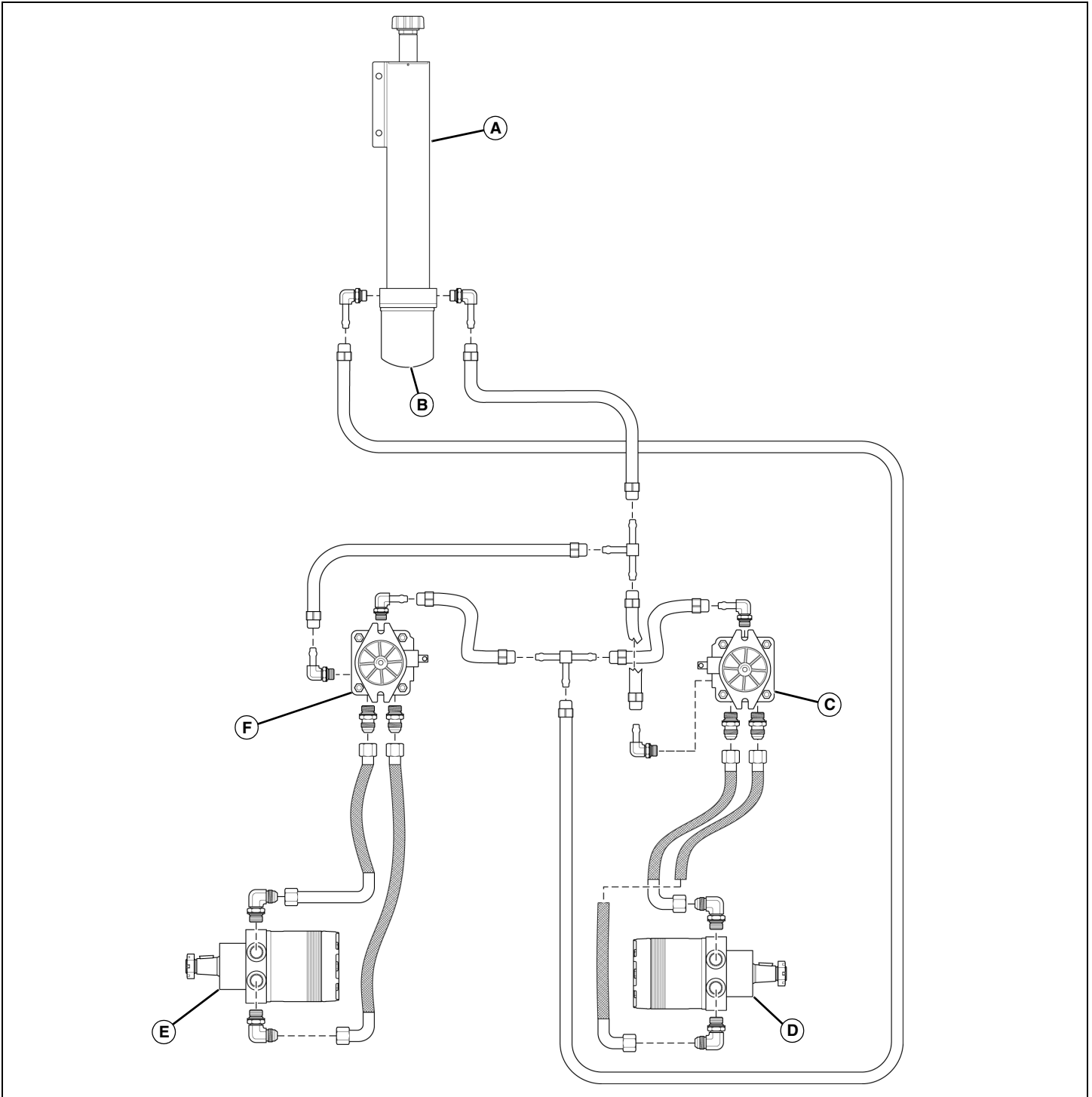

MX15332

- A - Hydraulic Reservoir**
- B - Oil Filter**
- C - Right Hydraulic Pump**
- D - Right Wheel Motor**
- E - Left Wheel Motor**
- F - Left Hydraulic Pump**

SERVICE TRANSMISSION

Hydraulic System Schematic

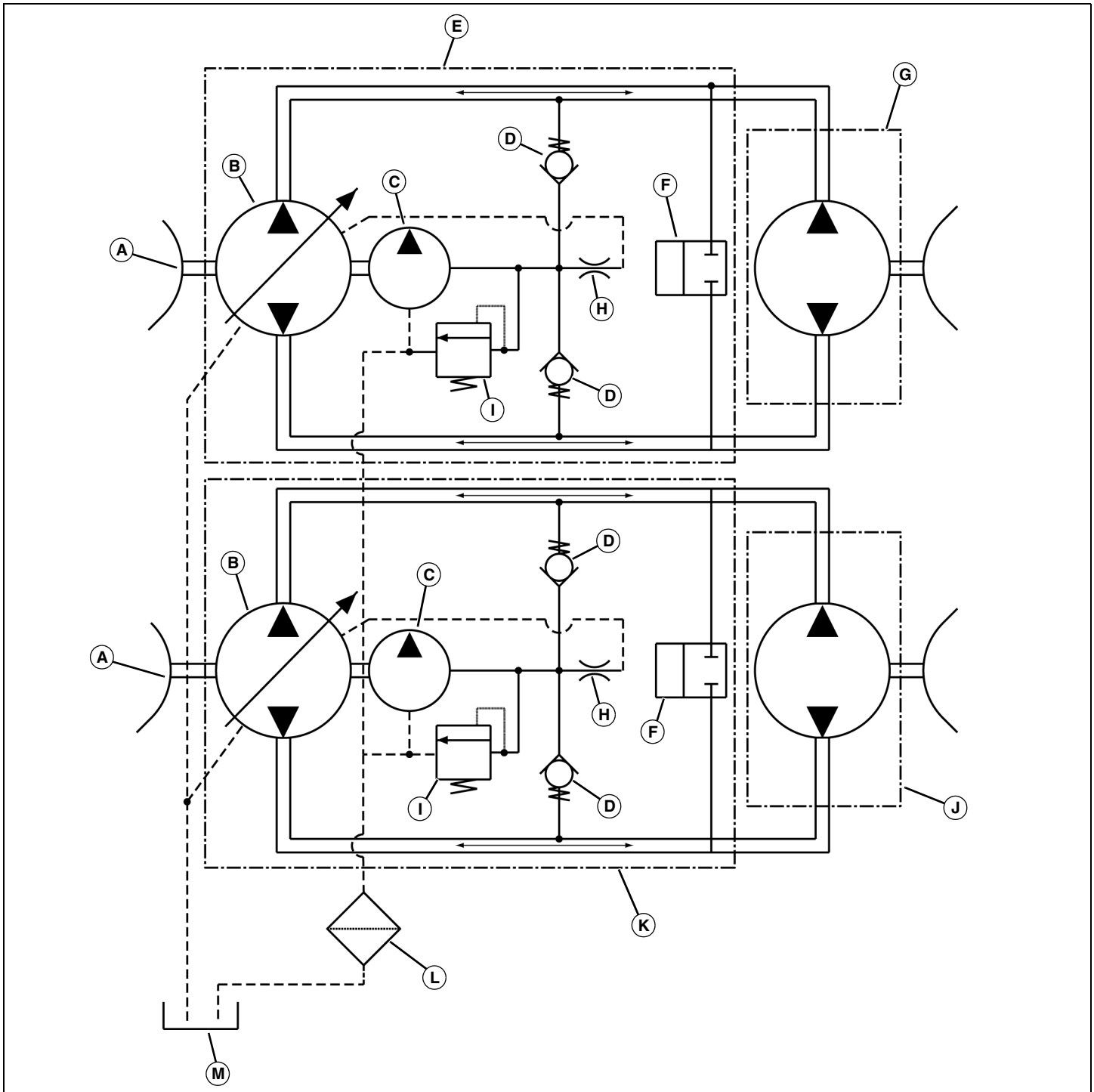

MX15333

A - Control Input Shaft

B - Pump Block

C - Charge Pump

D - Charge System Check Valve

E - Right Hydraulic Pump

F - Manual Bypass (Free-Wheel) Valve

G - Right Wheel Motor

H - Cooling Orifice

I - Charge Relief Valve

J - Left Wheel Motor

K - Left Hydraulic Pump

L - Oil Filter

M - Hydraulic Reservoir

SERVICE STEERING & BRAKES

Remove and Install Front Caster Wheels

Removing

1. Park machine safely. (See Parking Safely in the Safety section.)
2. Lift front of machine with a safe lifting device.

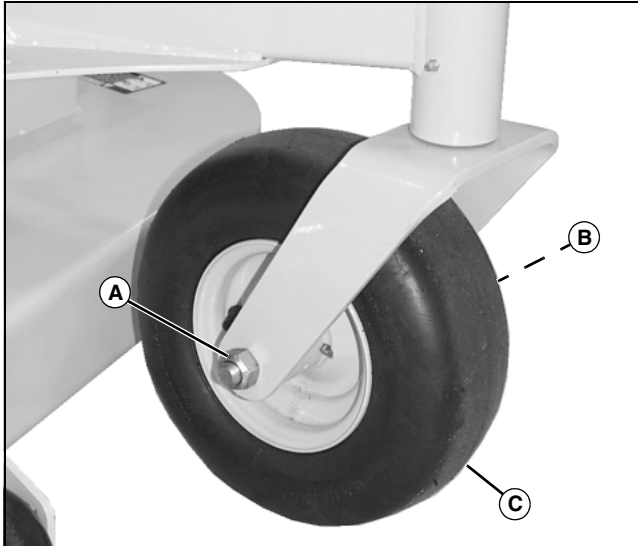

MX15323

3. Remove hex nut (A) and wheel bolt (B).
4. Remove wheel (C) from assembly yoke.

Installing

1. Install replacement wheel (C).
2. Install wheel bolt (B) and hex nut (A).
3. Tighten nut.
4. Lower machine.

Servicing Front Caster Wheel Roller Bearings - Chariot

1. Park machine safely. (See Parking Safely in the Safety section.)
2. Raise and securely support the front of the mower deck.

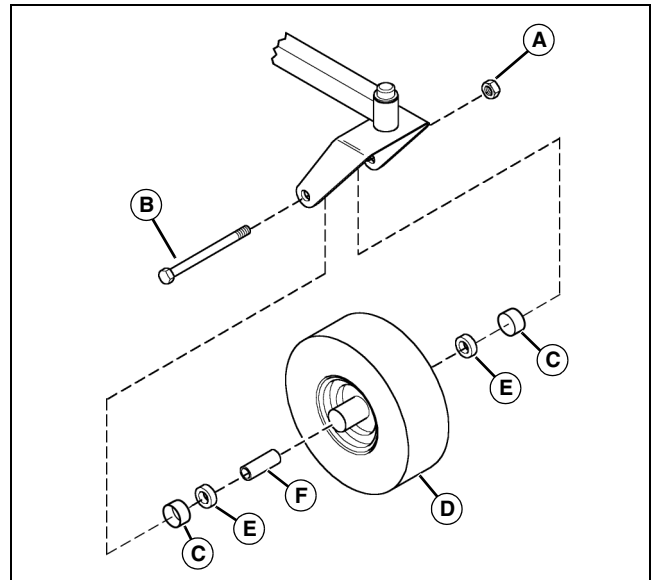

MX15324

3. Remove locknut (A), capscrew (B), two trash guards (C) and wheel and tire assembly (D).
4. Remove bearings (E) and spacer tube (F) from wheel.
5. Wipe clean and inspect bearings (E). Replace bearings as needed.
6. Install spacer tube (F), press bearings (E) into wheel and tire assembly.
7. Install wheel and tire assembly (D), two trash guards (C), capscrew (B) and locknut (A).

Servicing Front Caster Wheel Roller Bearings - Chariot LX

1. Park machine safely. (See Parking Safely in the Safety section.)
2. Raise and securely support the front of the mower deck.

SERVICE STEERING & BRAKES

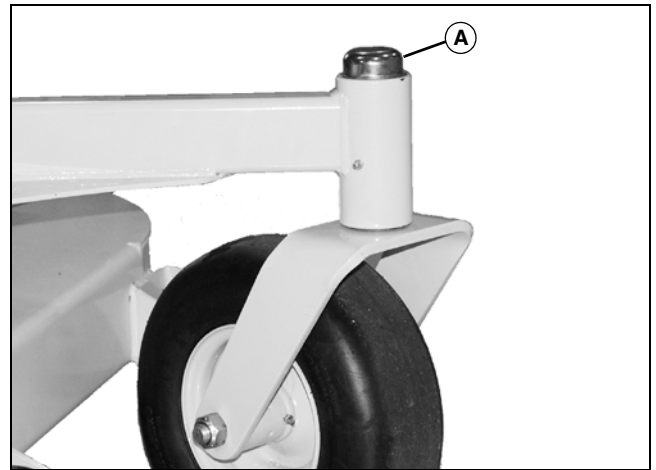
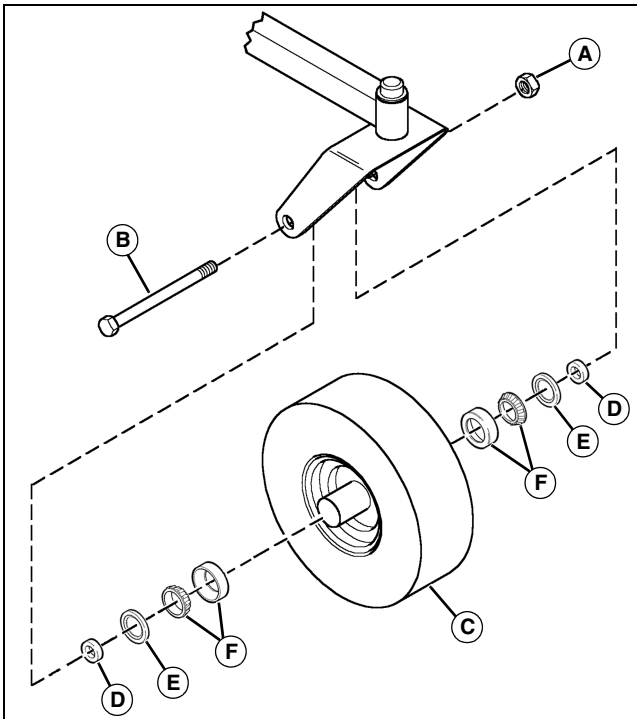

2. Remove dust cover (A) from top of spindle.

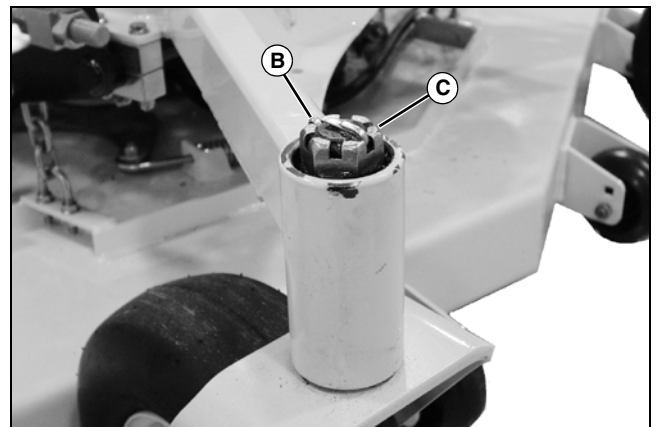

3. Remove locknut (A), cap screw (B) and wheel assembly (C).
 4. Remove spacers (D), seals (E) and bearings and bearing races (F) from wheel.
 5. Clean and inspect bearings (F) and pack with clean grease. Replace bearings with races as needed.
 6. Install bearings and races (F) and new seals (E).
 7. Install wheel assembly (C), two spacers (D), cap screw (B) and locknut (A). Tighten locknut until rolling resistance is felt.
3. Remove cotter pin (B).
 4. Turn castle nut (C) 1/4 turn clockwise.
 5. Install a new cotter pin. Do not loosen the castle nut to align cotter pin hole, tighten to align.
 6. Replace dust cover.
 7. Test machine to determine if shimmy is still present. Repeat adjustment as necessary.

Adjusting Front Caster Spindle Bearing

NOTE: Adjustment required only if the front caster wheel shimmies during travel.

1. Park machine safely. (See Parking Safely in the Safety section.)

Servicing Caster Spindle Bearings

1. Park machine safely. (See Parking Safely in the Safety section.)
2. Raise and securely support the front of the mower deck.

SERVICE STEERING & BRAKES

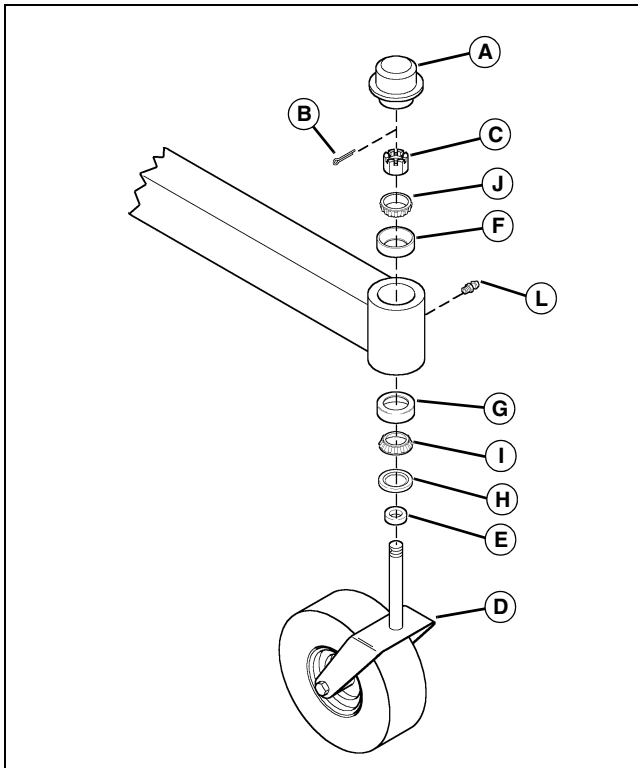

3. Remove cap (A), cotter pin (B), castle nut (C), castor yoke and wheel assembly (D) and castor bushing (E).

NOTE: It is not necessary to remove the bearing races (F and G), unless the bearings need to be replaced.

4. Remove seal (H) and lower bearing (I).

5. Remove upper bearing (J).

6. Clean and inspect bearings (I and J); pack with clean grease. Replace bearings if needed.

7. Install lower bearing (I).

8. Install castor bushing (E) into a new seal (H).

9. Install seal assembly (H).

10. Carefully install castor yoke and wheel assembly (D).

NOTE: Do not overtighten castle nut (C). Tighten castle nut only enough to install the cotter pin (B). The castor wheel yoke assembly must be free to rotate.

11. Install castle nut (C), cotter pin (B) and cap (A).

12. Apply grease to lubrication fitting (L).

Checking and Aligning Motion Control Levers - Standard "Center Steer" Levers

Check Alignment:

1. Park machine safely. (See Parking Safely in the Safety section.)

2. The control lever gap is pre-set at the factory. If the gap requires adjustment, see your authorized Great Dane servicing dealer.

Height Adjustment Procedure

The position of the control levers can be varied higher or lower by approximately 25 mm (1 in.) depending on the holes chosen for mounting the lever.

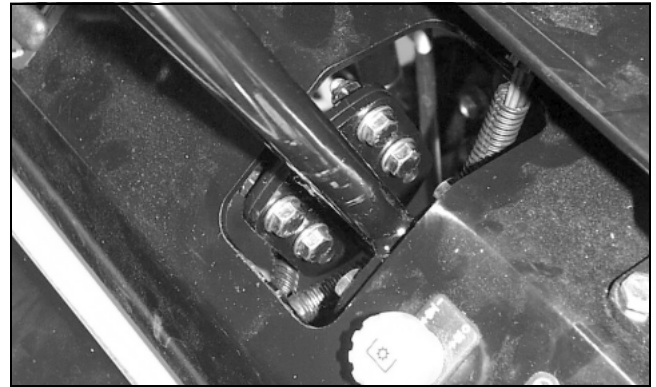

- To mount in the high position, mount the levers to the top four holes in the mounting bracket.

- To mount in the low position, mount the levers to the bottom four holes in the mounting bracket.

Checking and Aligning Motion Control Levers - Optional "Over the Lap" Levers

Check Alignment:

1. Park machine safely. (See Parking Safely in the Safety section.)

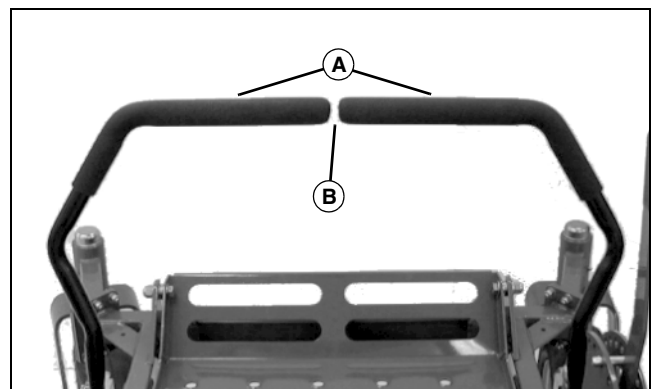

2. Move both motion control levers (A) from the neutral lock to the neutral steer position.

3. Check levers for equal alignment.

- Check gap (B) between the levers. The recommended gap is 3-6 mm (1/8-1/4 in.).

SERVICE STEERING & BRAKES

NOTE: If the ends of the levers strike against each other while in the neutral position, move the levers to the neutral lock position and carefully bend them outward. Move them back to the neutral position and check for the recommended gap of 3-6 mm (1/8-1/4 in.).

- If positions of the control levers are unequal, an adjustment is necessary.

Alignment Procedure

1. Adjust position of motion control levers:

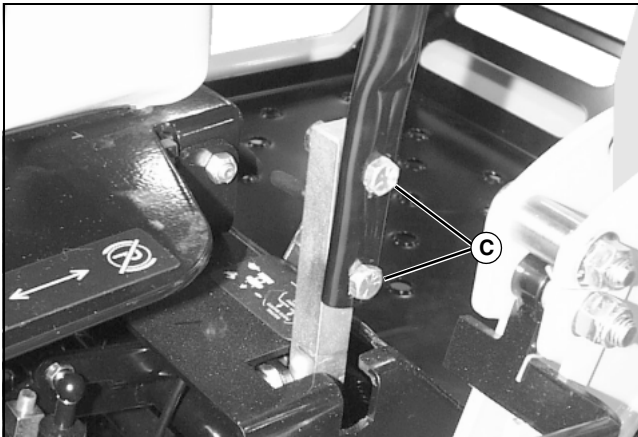

MX15353

- Loosen capscrews (C).
- Slide both levers forward or rearward to desired position on control arm until levers are aligned.
- Tighten capscrews.

Adjusting Park Brake

IMPORTANT: Avoid damage! Due to initial brake wear, the park brake should be checked and adjusted after the first 25 hours of use.

A park brake that is adjusted too tightly could damage the transmission or cause premature brake wear.

1. Park machine safely. (See Parking Safely in the Safety section.)

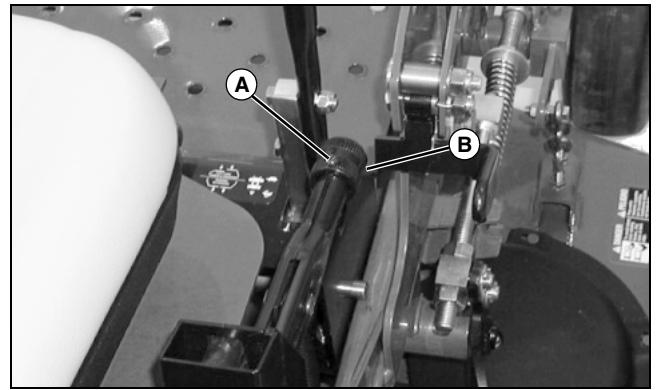

MX13130

2. Loosen set screw (A).
3. Turn knob (B) clockwise several times.
4. Tighten set screw down in the lower slot.
5. Test park brake.

SERVICE MOWER

Removing and Installing Mower Deck Foot Plate

 **CAUTION:** Avoid injury! Help prevent serious personal injury. Do not operate the mower without the foot plate installed.

Removing Foot Plate

1. Park machine safely. (See Parking Safely in the Safety section.)

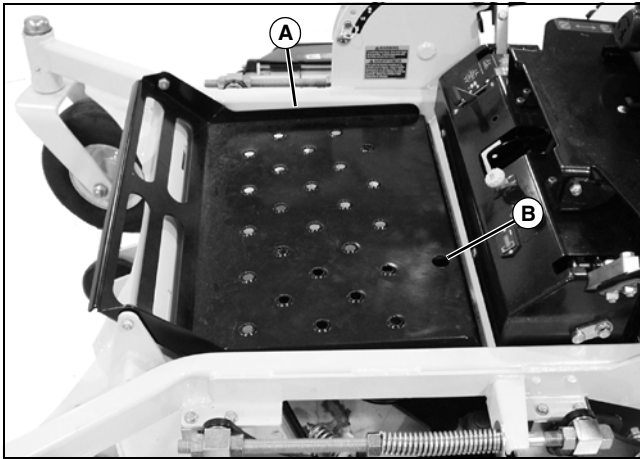

MX15314

2. Raise foot plate (A) using hole (B).

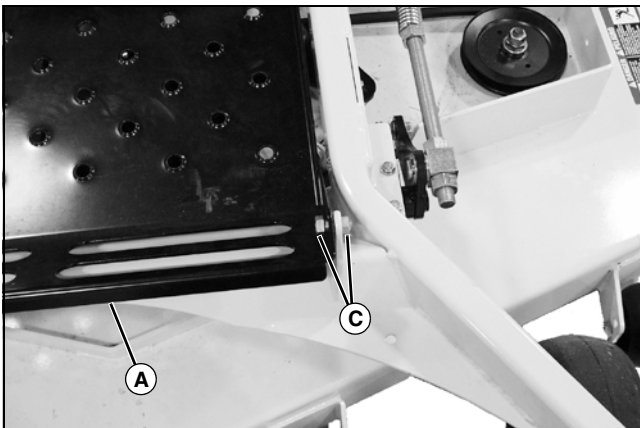

MX15315

3. Remove and retain hardware (C) securing foot plate (A) on both sides of machine.

4. Remove foot plate.

Installing Foot Plate

1. Install foot plate (A) using hardware (C) saved earlier.
2. Lower foot plate.

Removing and Installing Mower Deck Belt Shields

 **CAUTION:** Avoid injury! Help prevent serious personal injury. Do not operate the mower without the belt shields installed.

Removing Belt Shields

1. Park machine safely. (See Parking Safely in the Safety section.)

2. Lower mower deck to the lowest cutting height position.

NOTE: Two retaining knobs are used on each cover on the 72-inch mower deck.



MX15302

Picture Note: 48-, 52- and 61-inch mower deck belt shield.

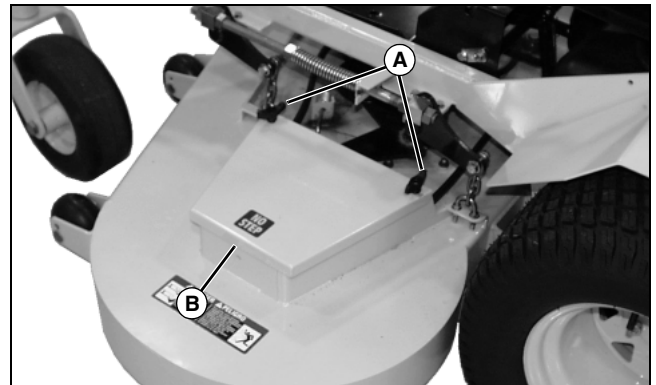

MX15303

Picture Note: 72-inch mower deck belt shield.

3. Remove knob(s) (A).
4. Remove belt shield (B).

Installing Belt Shields

1. Install belt shield (B).
2. Install knob(s) (A).

SERVICE MOWER

Leveling Mower Deck



CAUTION: Avoid injury! Rotating blades are dangerous. Before adjusting or servicing mower:

- Disconnect spark plug wire(s) to prevent engine from starting accidentally.
- Always wear gloves when handling mower blades or working near blades.

NOTE: Mower deck anti-scalp wheels should not contact the ground.

1. Park machine safely. (See Parking Safely in the Safety section.)
2. Inflate tires to the correct pressure.
3. Raise the mower deck lift lever to transport position.
4. Inspect mower blades for:
 - Blade sharpness.
 - Blade damage.
 - Bent blades.

Checking Level (Side-to-Side)

NOTE: Mower deck anti-scalp wheels should not contact the ground.

1. Lower deck to the 76 mm (3 in.) cutting height position.

NOTE: Position the left mower blade in the sideways (left-to-right) position.

Use a short ruler or a leveling gauge to check the mower blade level.

2. Measure from outside blade tip to the ground.

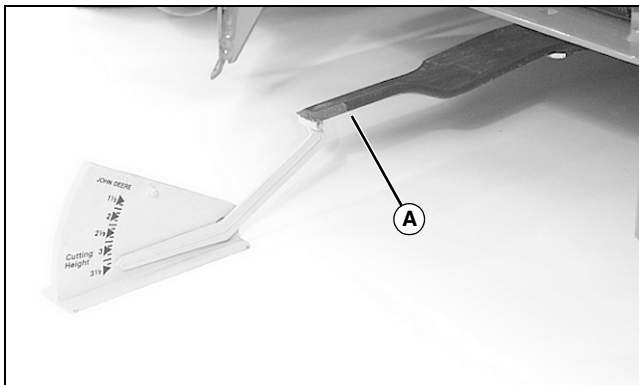

MX10371

Picture Note: Discharge chute raised for photo clarity.

3. Position right mower blade (A) (discharge side) in the side-to-side position.

4. Measure from outside blade tip to the ground.

- The difference between both measurements should be no greater than 3 mm (1/8 in.).

5. If side-to-side level is not within specifications, an adjustment is necessary.

Adjusting Level (Side-to-Side)

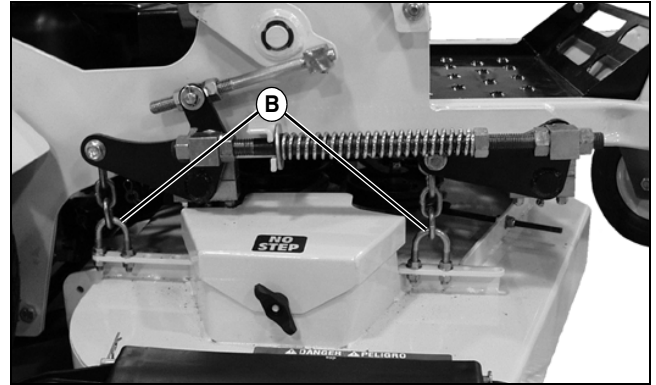

MX15285

1. Adjust four chain U-bolts (B) (two on each side of deck) until deck is within 3 mm (1/8 in.) of level from side to side.

Checking Level (Front-to-Rear)

1. Lower mower deck to the 76 mm (3 in.) cutting height position.
2. Position right mower blade (discharge side) in the straight forward (front-to-rear) position.
3. Measure from right front blade tip to the ground.
4. Turn blade 180° and measure from right rear blade tip to the ground.

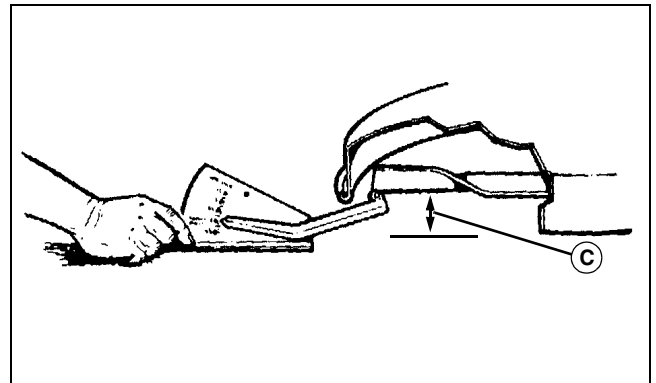

M40137

- The height (C) of the rear blade tip should be 3-6 mm (1/8-1/4 in.) higher than the front blade tip.

5. If the front-to-rear level is not within specifications, an adjustment is necessary.

SERVICE MOWER

Adjusting Level (Front-to-Rear)

IMPORTANT: Avoid damage! Adjust the left and right deck lift assist rods equally.

NOTE: Adjust side-to-side mower level before adjusting front-to-rear level.

Chariot LX model is equipped with a deck lift assist rod on each side of machine. Adjust both sides of the mower deck equally.

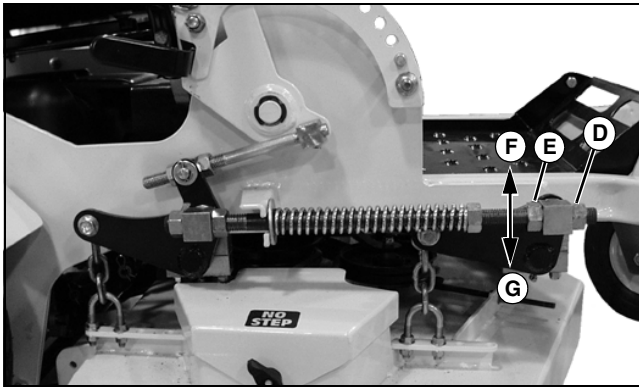

1. Loosen jam nut (D) on deck lift assist rod.
2. While positioned in front of the machine, adjust mower level:
 - Turn hex nut (E) counterclockwise (F) to lower front of mower deck.
 - Turn hex nut (E) clockwise (G) to raise front of mower deck.
3. For Chariot LX model, repeat for other side. Verify that the adjustment on right and left sides is equal.
4. Tighten jam nuts.
5. Check front-to-rear mower level.

Checking and Adjusting Cutting Height



CAUTION: Avoid injury! Rotating blades are dangerous. Before adjusting or servicing mower:

- Disconnect spark plug wire(s) to prevent engine from starting accidentally.
- Always wear gloves when handling mower blades or working near blades.

Checking Thrust Arm-to-Stop Rod Clearance (Transport Position)

1. Set mower deck to transport (fully raised) position.

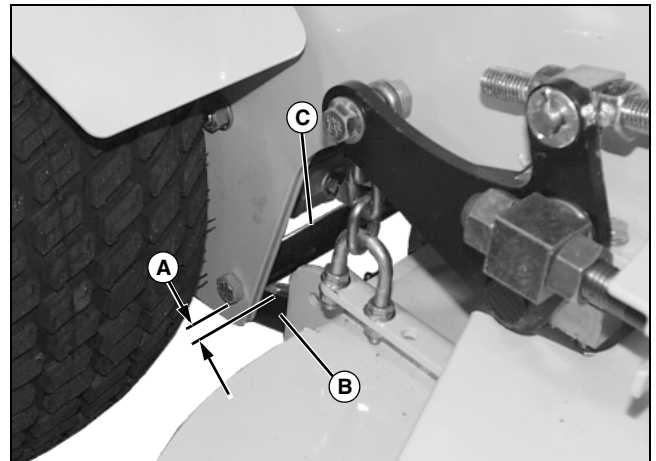

2. Check clearance (A) from the top of the thrust arms (B) to the bottom of the thrust arm stop rod (C). The clearance should be 3 mm (1/8 in.).

Adjust Thrust Arm-to-Stop Rod Clearance (Transport Position)

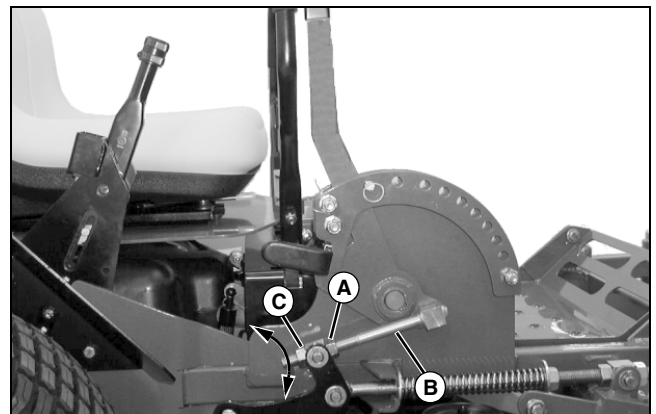

1. Loosen jam nut (A).

NOTE: If correct adjustment cannot be obtained by adjusting the lift handle connecting rod, further movement can be gained by adjusting the chain U-bolts.

Adjust all four chain U-bolts equally. All four chains should be tight. Tighten the U-bolt of the loose chain to correct.

2. Adjust deck lift handle connecting rod (B) while viewing adjusting mechanism from rear of machine.
 - To lower deck, turn nut (C) counterclockwise.
 - To raise deck, turn nut (C) clockwise.
3. Tighten jam nut (A).

SERVICE MOWER

Adjusting Deck Lift Assist Spring Tension

NOTE: Deck lift assist spring tension is adjusted at the factory. If the effort required to raise or lower the mower deck is not satisfactory, an adjustment may be necessary.

Check Spring Tension

1. Park machine on a hard, level surface.
2. Stop engine and lock park brake.
3. Raise the mower deck lift lever to the transport position.

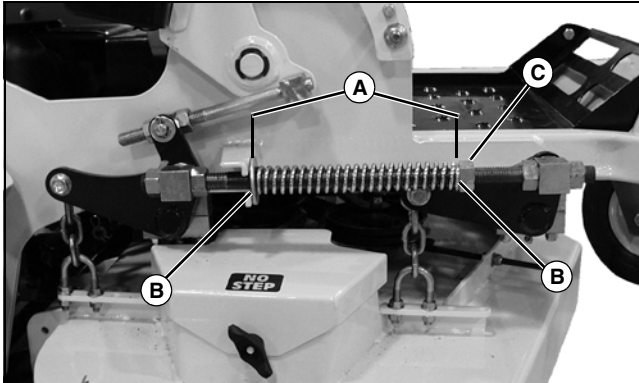

4. Measure distance (A) between the washers (B) on each deck lift spring assembly.

- The recommended factory setting is approximately 1 mm (1/32 in.) gap between the spring coils at the lowest HOC setting.

Adjust Assist Spring Tension

NOTE: The Chariot LX is equipped with two deck lift assist spring assemblies. Both deck lift assist springs must be adjusted equally.

Do not overtighten the deck lift assist springs. If the springs are compressed too tightly, the mower deck will float too freely.

Decrease deck lift assist spring tension if operating in rough terrain.

While positioned in front of the machine:

- Turn hex nut (C) clockwise to increase deck lift spring tension and reduce the effort to raise and lower the mower deck.
- Turn hex nut (C) counterclockwise to decrease deck lift spring tension and increase the effort to raise and lower the mower deck.

Checking and Adjusting Mower Deck Drive Belt Tension - 48-, 52- and 61-Inch Mower Deck

1. Park machine safely. (See Parking Safely in the Safety section.)
2. Adjust the mower deck for the lowest cutting height, and lower the deck.
3. Raise foot platform.

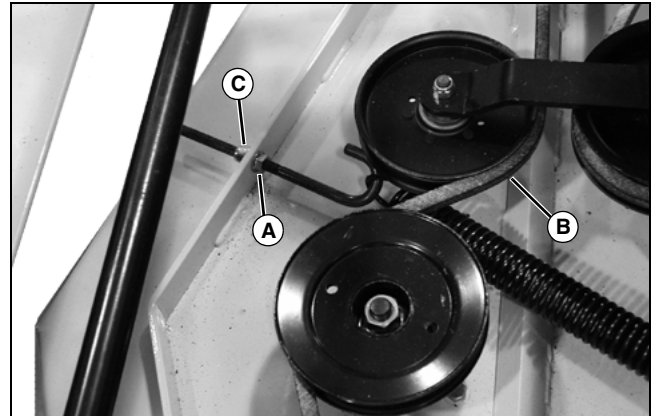

4. Loosen jam nut (A).
5. Check the mower deck drive belt (B) tension. The belt should deflect a maximum of 13 mm (1/2 in.) when a force of 4.5 kg (10 lb) is applied to the center of the longest span. When properly adjusted, there would be approximately a 2 mm (1/16 in.) gap between the spring coils.
 - To increase belt tension: Turn nut (C) clockwise.
 - To decrease belt tension: Turn nut (C) counterclockwise.
6. Tighten jam nut (A).
7. Lower foot platform.

Checking and Adjusting Engine-to-Deck Drive Belt Tension - 72-Inch Mower Deck

1. Park machine safely. (See Parking Safely in the Safety section.)
2. Adjust the mower deck for the lowest cutting height, and lower the deck.
3. Raise foot platform.

SERVICE MOWER

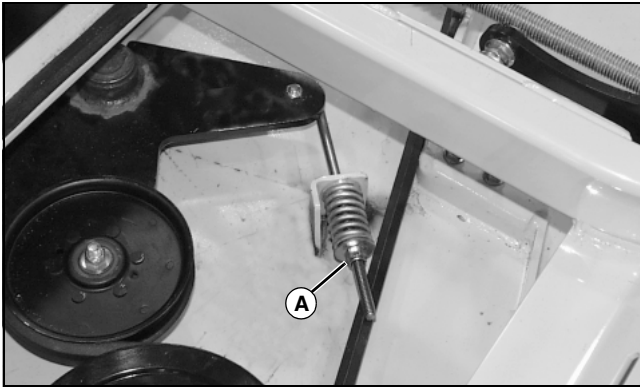

MX15328

4. Check the engine-to-deck drive belt tension. The belt should deflect a maximum of 13 mm (1/2 in.) when a force of 4.5 kg (10 lb) is applied to the center of the longest span.

When properly adjusted, there would be approximately a 2 mm (1/16 in.) gap between the spring coils.

- To increase belt tension: Turn nut (A) clockwise.
- To decrease belt tension: Turn nut (A) counterclockwise.

Checking and Adjusting Spindle Drive Belt Tension - 72-Inch Mower Deck

1. Park machine safely. (See Parking Safely in the Safety section.)
2. Adjust the mower deck for the lowest cutting height, and lower the deck.
3. Raise foot platform.

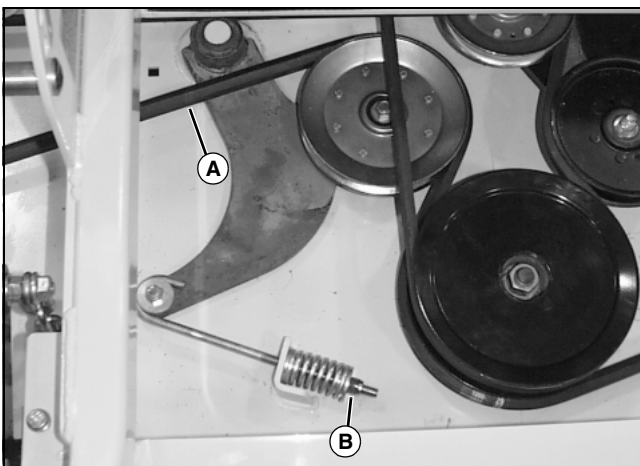

MX15327

4. Check the spindle drive belt (A) tension. The belt should deflect a maximum of 13 mm (1/2 in.) when a force of 4.5 kg (10 lb) is applied to the center of the longest span.

When properly adjusted, there would be approximately an 2 mm (1/16 in.) gap between the spring coils.

- To increase belt tension: Turn nut (B) clockwise.
- To decrease belt tension: Turn nut (B) counterclockwise.

Removing and Installing Mower Deck Drive Belt - 48-, 52- and 61-Inch Mower Deck

1. Park machine safely. (See Parking Safely in the Safety section.)
2. Raise foot platform.
3. Remove mower deck drive belt covers.

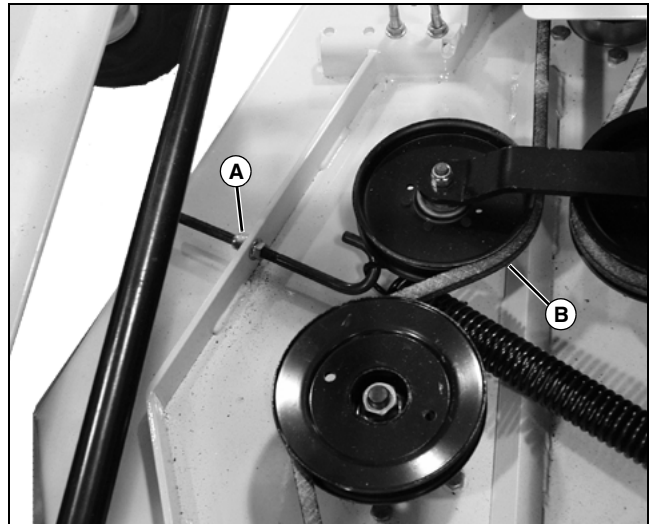

MX15317

4. Release mower deck drive belt tension by turning the tension adjuster nut (A) counterclockwise.
5. Remove mower deck drive belt (B).

SERVICE MOWER

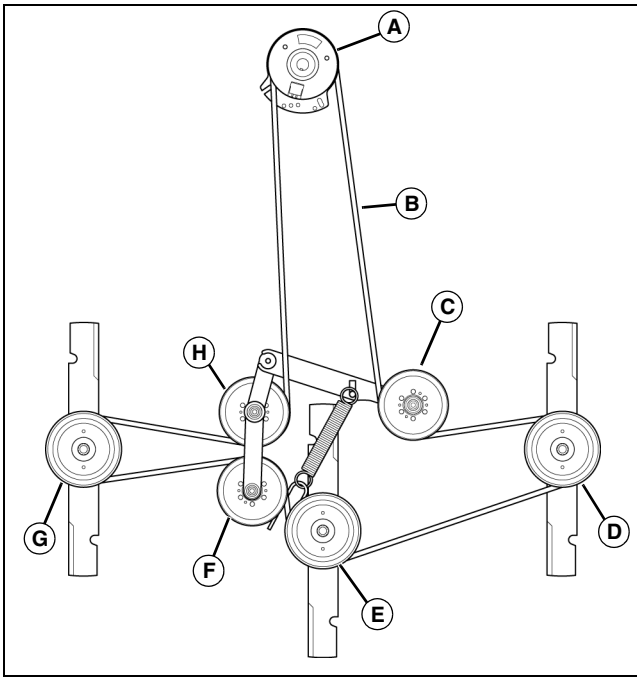

MX15318

- A - PTO Clutch Sheave**
- B - Mower Deck Drive Belt**
- C - Tension Idler Sheave**
- D - Left Spindle Sheave**
- E - Center Spindle Sheave**
- F - Idler Sheave**
- G - Right Spindle Sheave**
- H - Idler Sheave**

6. Install new mower deck drive belt (B) as shown.
7. Adjust belt tension.
8. Install mower deck drive belt covers.
9. Lower foot platform.

Removing and Installing Engine-to-Deck Drive Belt - 72-Inch Mower Deck

1. Park machine safely. (See Parking Safely in the Safety section.)
2. Remove mower deck drive belt covers.

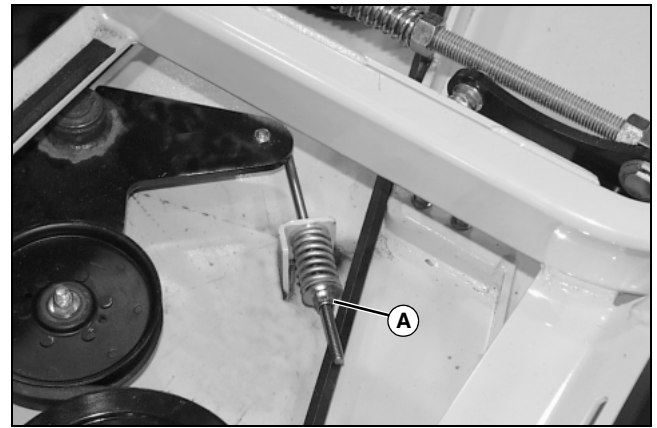

MX15328

3. Release engine-to-deck drive belt tension by turning the tension adjuster nut (A) counterclockwise.

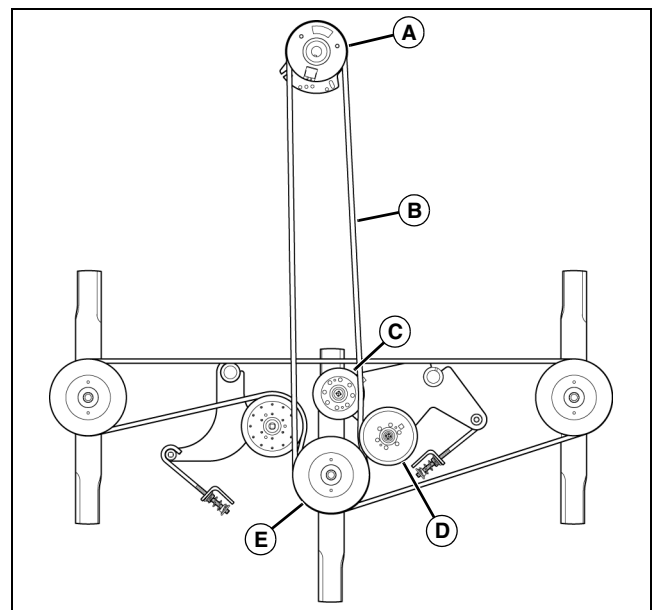

MX15329

- A - PTO Clutch Sheave**
- B - Mower Deck Drive Belt**
- C - Tension Idler Sheave**
- D - Tension Idler Sheave**
- E - Center Spindle Sheave**

4. Remove engine-to-deck drive belt (B).
5. Install new engine-to-deck drive belt (B) as shown.
6. Adjust drive belt tension.
7. Install mower deck drive belt covers.
8. Lower foot platform.

SERVICE MOWER

Removing and Installing Spindle Drive Belt - 72-Inch Mower Deck

1. Park machine safely. (See Parking Safely in the Safety section.)
2. Raise foot platform.
3. Remove mower deck drive belt covers.

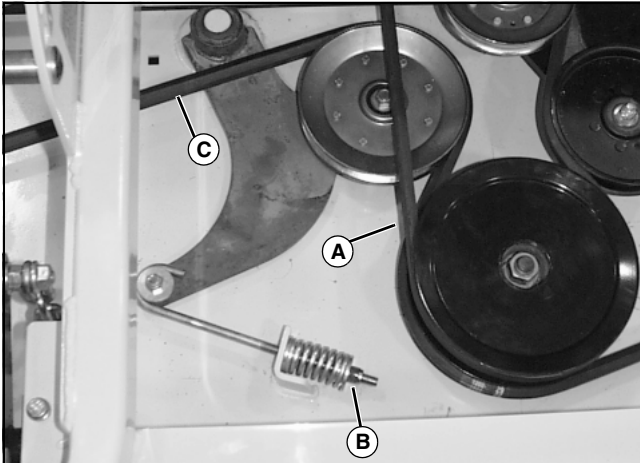

MX15327

4. Remove engine-to-deck drive belt (A).
5. Release spindle drive belt tension by turning tension adjustment nut (B) counterclockwise.
6. Remove spindle drive belt (C).

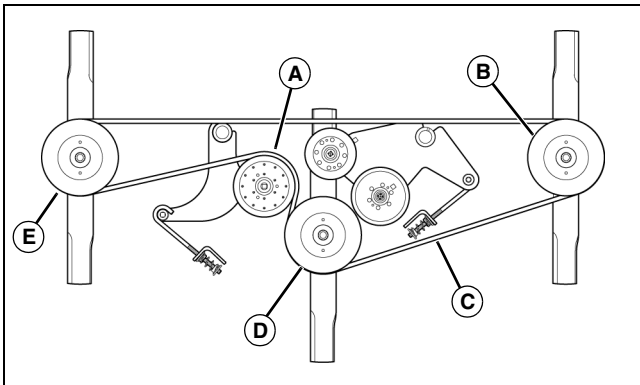

MX15330

- A - Tension Idler Sheave**
- B - Left Spindle Sheave**
- C - Spindle Drive Belt**
- D - Center Spindle Sheave**
- E - Right Spindle Sheave**

7. Install new spindle drive belt (C) as shown.
8. Adjust drive belt tension.
9. Install engine-to-deck drive belt and adjust belt tension.
10. Install mower deck drive belt covers.
11. Lower foot platform.

Checking and Replacing Mower Blades



CAUTION: Avoid injury! Help prevent serious personal injury. Do not work near a raised mower deck unless it is safely supported.

Never start the engine or engage the PTO switch when performing this service procedure.

Blades are sharp and could cause personal injury. Wear appropriate clothing including gloves when working near the underside of a raised mower deck.

Before performing any service function, wait for all moving parts to stop turning.

IMPORTANT: Avoid damage! When replacing mower blades, always use genuine Great Dane Service Parts.

NOTE: Only replace blades. Never straighten or weld them.

Checking Mower Blades

1. Park machine safely. (See Parking Safely in the Safety Section).
2. Raise the mower deck to the transport position (also the 12.7 cm [5 in.] cutting height position).
3. Raise front of machine with a safe lifting device.
 - Support with jack stands and/or wooden blocks.
4. Check mower blades:
 - Mower blades should be sharp and free of any damage.
 - Inspect blades; sharpen/balance or replace as necessary.

SERVICE MOWER

Replacing Mower Blades

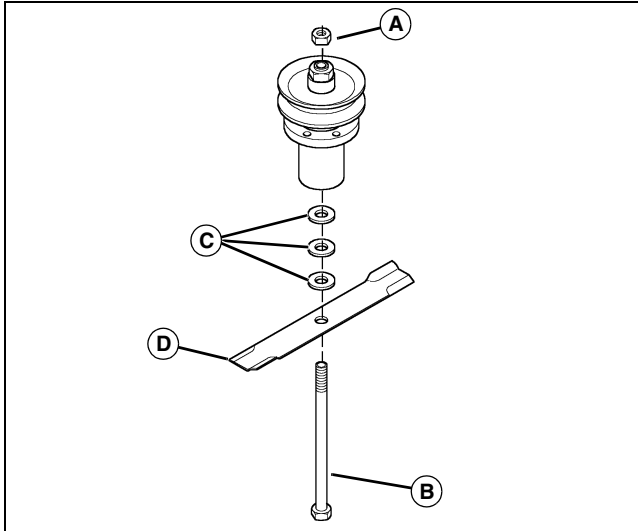

MX15357

1. Use two long-handled 15/16 in. wrenches to loosen nut (A).
2. Remove nut (A), blade bolt (B), three 1/4 in. washers (C) and blade (D).
3. Install replacement blade:
 - Blade wing must face toward top of mower deck.

IMPORTANT: Avoid damage! When installing the blade:

- Make sure the blade is properly seated on the spindle.
- Make sure the concave side of the large washer faces toward the blade.

- Install blade bolt (B), blade (D), three 1/4 in. washers (C) and nut (A).
 - Tighten blade nut to 81 N•m (60 lb-ft).
4. Lower machine.
 5. Adjust mower deck to a desirable cutting height.

Sharpening Blades

CAUTION: Avoid injury! Mower blades are dangerous!

- Always wear gloves while working on blades.
- Always wear safety eye protection when grinding.

- Sharpen blades with grinder, hand file or electric blade sharpener.

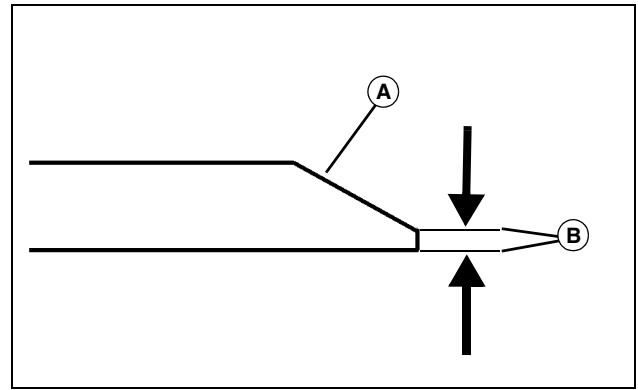

MX8333

- Keep original bevel (A) when grinding.
- Blade should have 0.40 mm (1/64 in.) cutting edge (B) or less.
- Balance blades before installing.

Balancing Blades



CAUTION: Avoid injury! Mower blades are sharp. Always wear gloves when handling mower blades or working near blades.

1. Clean blade.

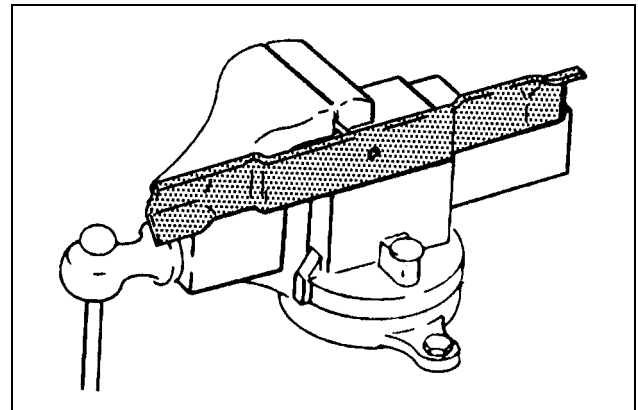

M61524

2. Put blade on nail in a vise. Turn blade to horizontal position.
3. Check balance. If blade is not balanced, heavy end of blade will drop.
4. Grind bevel of heavy end. Do not change blade bevel.

Replacing Mower Spindle Bearings - 48-, 52- and 61-Inch Mower Decks

1. Park machine safely. (See Parking Safely in the Safety section.)

SERVICE MOWER

2. Remove mower blade. (See Checking and Replacing Mower Blades.)

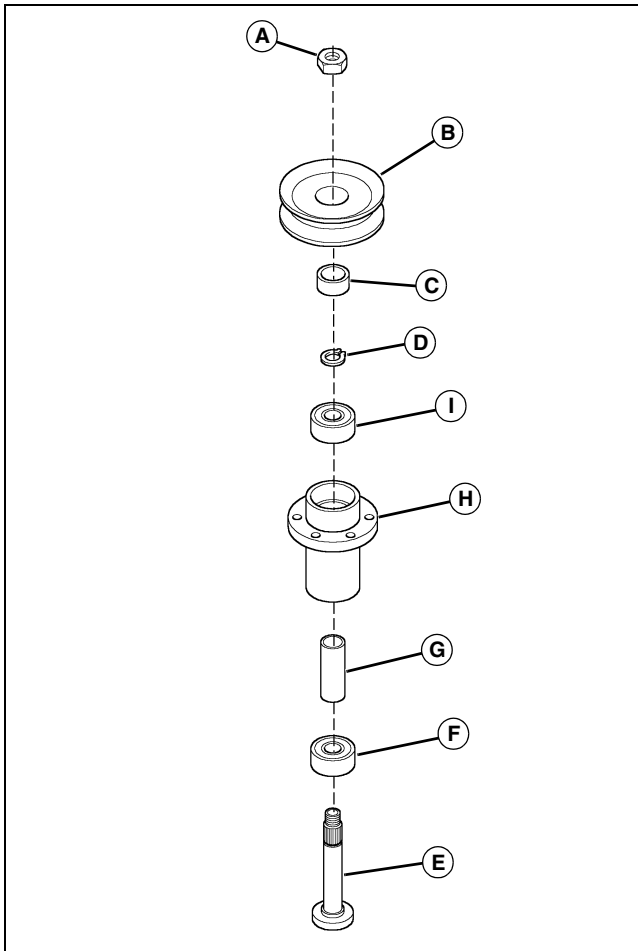

MX15354

3. Remove nut (A), pulley (B) and spacer (C).
4. Remove retaining ring (D), spindle shaft (E), lower bearing (F) and spacer (G) from spindle housing (H). Discard bearing.
5. Remove and discard upper bearing (I).
6. Clean entire assembly.
7. Install a new lower bearing (F) and spacer (G) on the spindle shaft (E).

IMPORTANT: Avoid damage! The clearance between the lower bearing and the housing is only 0.05 mm (0.002 in.). Do not force bearing into housing.

8. Install the spindle shaft (E), lower bearing (F) and spacer (G) into the spindle housing (H).
9. Install the upper bearing (I) and retaining ring (D).
10. Install spacer (C).
11. Install pulley (B) and nut (A). Tighten nut to 61 N•m (50 lb-ft).

12. Install mower blade, blade washers and blade bolt assembly. Tighten nut to 81 N•m (60 lb-ft). (See Checking and Replacing Mower Blades.)

Replacing Mower Spindle Bearings - 72-Inch Mower Deck

1. Park machine safely. (See Parking Safely in the Safety section.)
2. Remove engine-to-deck drive and spindle drive belts.
3. Remove mower blade. (See Checking and Replacing Mower Blades.)

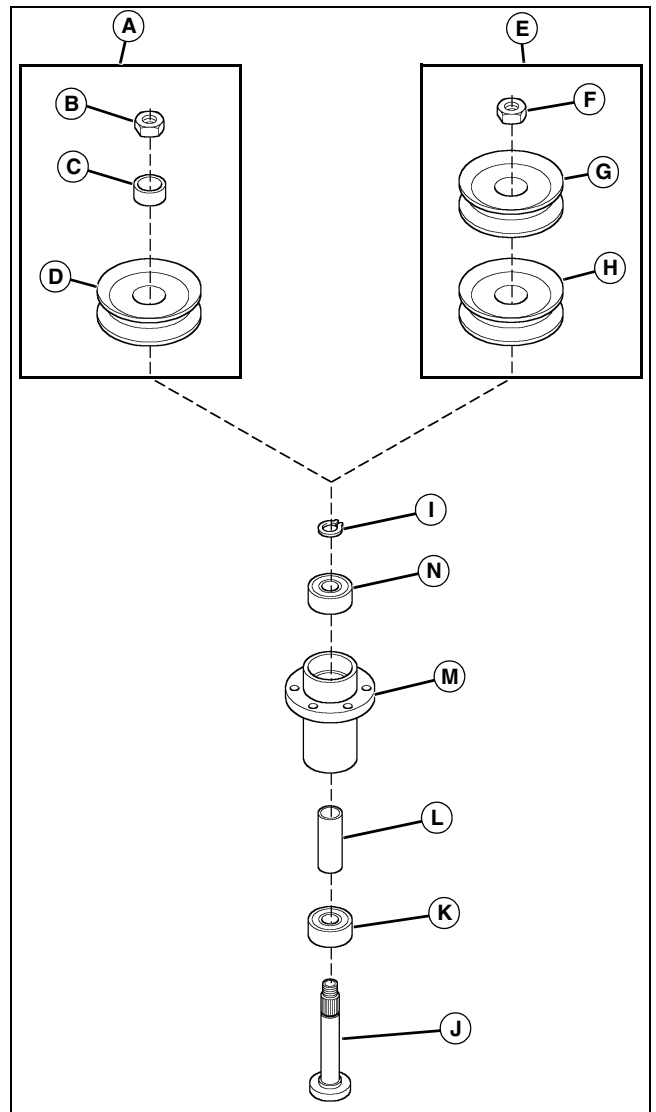

MX9222

4. Remove pulleys:
 - **Right and Left Spindles (A):** Remove nut (B), spacer (C) and pulley (D).
 - **Center Spindle (E):** Remove nut (F), drive pulley (G) and spindle pulley (H).

SERVICE MOWER

5. Remove retaining ring (I), spindle shaft (J), lower bearing (K) and spacer (L) from spindle housing (M). Discard bearing.
6. Remove and discard upper bearing (N).
7. Clean entire assembly.
8. Install a new lower bearing (K) and spacer (L) on the spindle shaft (J).

IMPORTANT: Avoid damage! The clearance between the lower bearing and the housing is only 0.05 mm (0.002 in.). Do not force bearing into housing.

9. Install the spindle shaft (J), lower bearing (K) and spacer (L) into the spindle housing (M).
10. Install the upper bearing (N) and retaining ring (I).
11. Install upper pulleys:
 - **Right and Left Spindles (A):** Install pulley (D), spacer (C) and nut (B). Tighten nut to 81 N•m (60 lb-ft).
 - **Center Spindle (E):** Install spindle pulley (H), drive pulley (G) and nut (F). Tighten nut to 81 N•m (60 lb-ft).
12. Install mower blade, blade washers and blade bolt assembly. Tighten nut to 81 N•m (60 lb-ft). (See Checking and Replacing Mower Blades.)

SERVICE ELECTRICAL

WARNING: Battery posts, terminals and related accessories contain lead and lead components, chemicals known to the State of California to cause cancer and reproductive harm. **Wash hands after handling.**

Removing and Installing the Battery



CAUTION: Avoid injury! The battery produces a flammable and explosive gas. The battery may explode:

- Do not smoke near battery.
- Wear eye protection and gloves.
- Do not allow direct metal contact across battery posts.
- Remove negative cable first when disconnecting.
- Install negative cable last when connecting.

Removing:

1. Park machine safely. (See Parking Safely in the Safety section.)

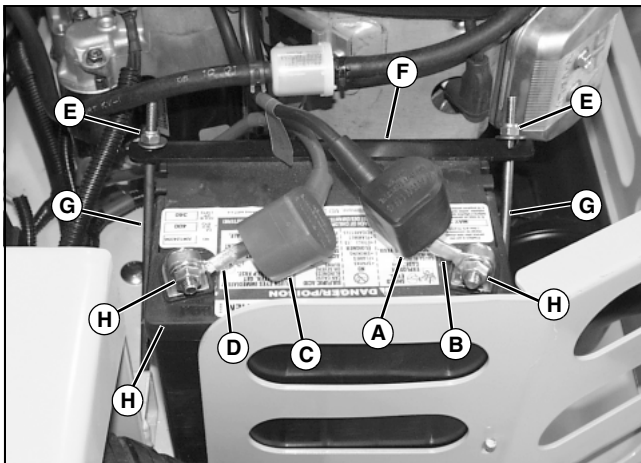

MX15326

2. Slide black cover (A) away from the negative battery terminal and disconnect the negative battery cable (B).
3. Slide red cover (C) away from the positive battery terminal and disconnect the positive battery cable (D).
4. Remove nuts (E) and washers from both sides of the bracket (F).
5. Remove bracket (F) and J-bolts (G).
6. Remove battery (H).

Installing:

1. Install battery (H) using J-bolts (G), bracket (F), washers and nuts (E).
2. Connect the positive battery cable (D) first, then the negative cable (B).
3. Apply petroleum jelly or silicone spray to the terminals to prevent corrosion.
4. Slide covers (A and C) over battery terminals.

Cleaning Battery and Terminals



CAUTION: Avoid injury! The battery produces a flammable and explosive gas. The battery may explode:

- Do not smoke near battery.
- Wear eye protection and gloves.
- Do not allow direct metal contact across battery posts.
- Remove negative cable first when disconnecting.
- Install negative cable last when connecting.

1. Disconnect and remove battery.
2. Wash battery with a solution of four tablespoons of baking soda to one gallon of water. Be careful not to get the soda solution into the battery cells.
3. Rinse the battery with plain water and dry.
4. Clean terminals and battery cable ends with wire brush until bright.
5. Install battery.
6. Attach cables to battery posts using washers and nuts (H).
7. Apply petroleum jelly or silicone spray to terminals to prevent corrosion.

SERVICE ELECTRICAL

Using Booster Battery



MIF TS204



CAUTION: Avoid injury! The battery produces a flammable and explosive gas. The battery may explode:

- Do not attempt to jump start a frozen battery. Warm to 16 degrees C (60 degrees F).
- Do not smoke near battery.
- Wear eye protection and gloves.
- Keep sparks and flames away.
- Do not connect the negative (-) booster cable to the negative (-) terminal of the discharged battery. Connect at a good ground location away from the discharged battery.
- Do not cross jump the battery, damage to electronic modules will result.

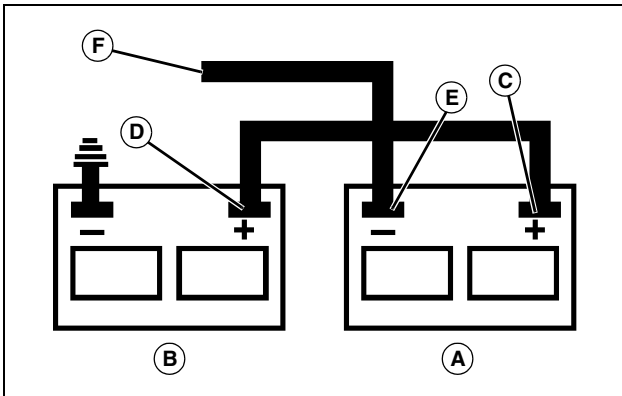

M71044

A - Booster Battery

B - Disabled Vehicle Battery

1. Connect positive booster cable to booster battery (A) positive post (C).
2. Connect the other end of positive booster cable to the disabled vehicle battery (B) positive post (D).

3. Connect negative booster cable to booster battery negative post (E).
4. Connect the other end (F) of negative booster cable to a unpainted metal part of the disabled machine's engine, away from battery.
5. Start the engine of the disabled machine and run machine for several minutes.
6. Carefully disconnect the booster cables in the exact reverse order: negative cable first and then the positive cable.

Replacing Fuse - Carbureted Engines

IMPORTANT: Avoid damage! When replacing fuses - use only a 20-amp fuse or you may damage the circuit.

One 20-amp fuse is located behind the seat area.



MX15336

1. Remove defective fuse (A) from socket.
2. Check metal clip in fuse window and discard fuse if clip is broken.
3. Install new fuse in socket.

Replacing Fuses - Fuel Injected Engines

IMPORTANT: Avoid damage! When replacing fuses - use only fuses of the same rating or you may damage the circuit.

SERVICE ELECTRICAL

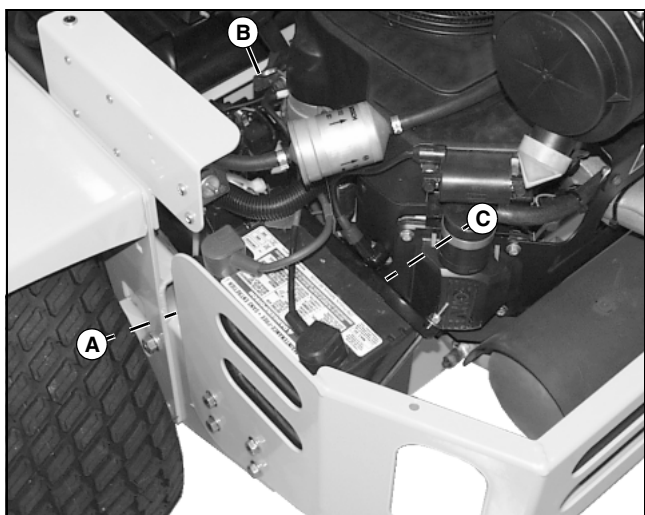

MX15337

Chariot LX models equipped with Kohler EFI engines have three additional fuses:

- One 10-amp fuse (A), used to protect the fuel pump circuit.
- One 20-amp fuse (B), used to protect the main power circuit.
- One 30-amp fuse (C), used to protect the charge circuit.

1. Remove defective fuse from socket.
2. Check metal clip in fuse window and discard fuse if clip is broken.
3. Install new fuse into socket.

Burnishing the PTO Clutch

NOTE: The clutch will only require burnishing if a new clutch has been installed.

1. Start and run the engine at 1/2 throttle.
2. Engage and disengage the PTO clutch five times (ten seconds on, ten seconds off).
3. Move throttle lever to 3/4 throttle.
4. Engage and disengage the PTO clutch five times (ten seconds on, ten seconds off).

SERVICE ELECTRICAL

Wiring Schematic - Carbureted Engines

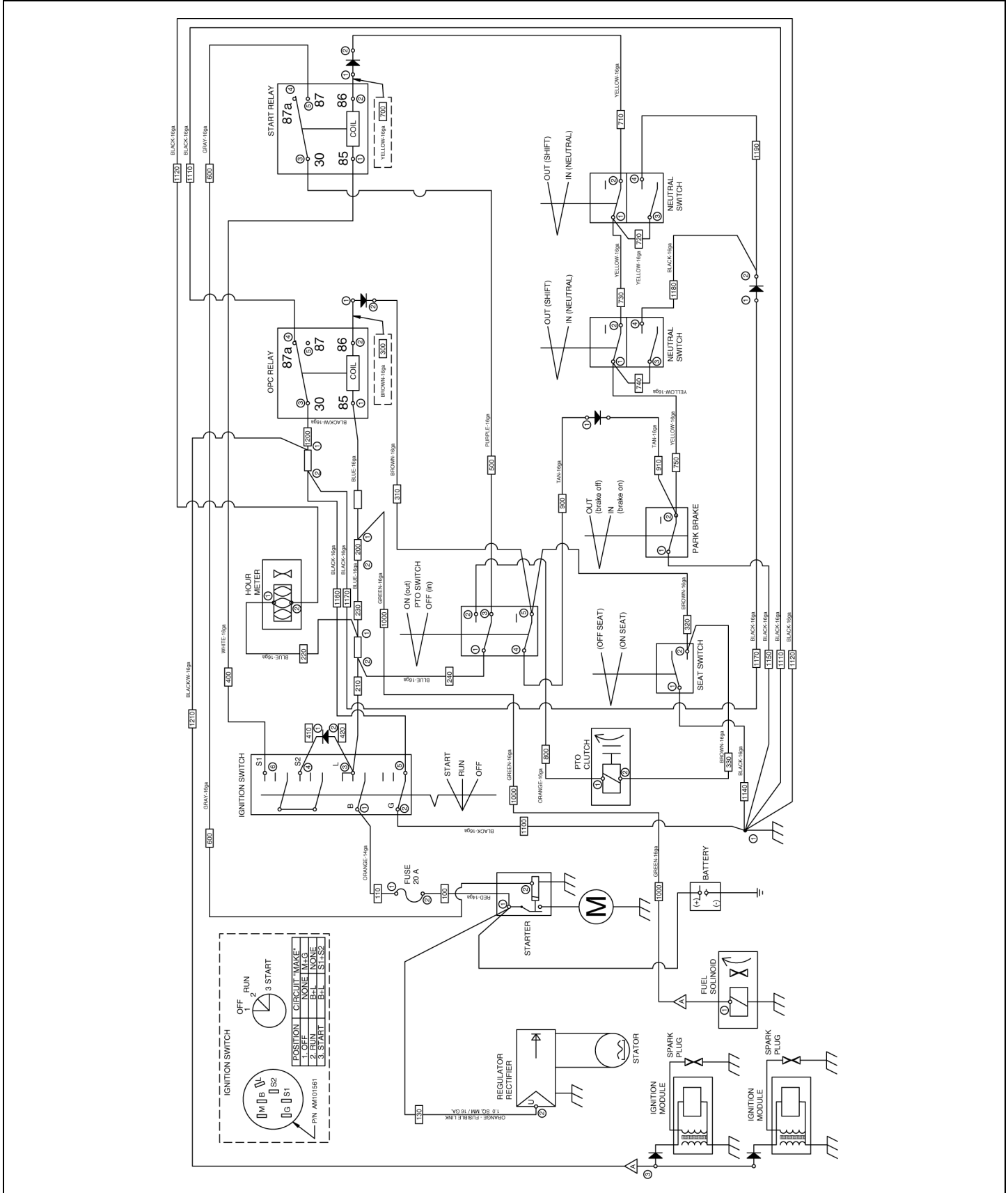

MX15338

SERVICE ELECTRICAL

Wiring Schematic - 26 HP Fuel Injected

Engine

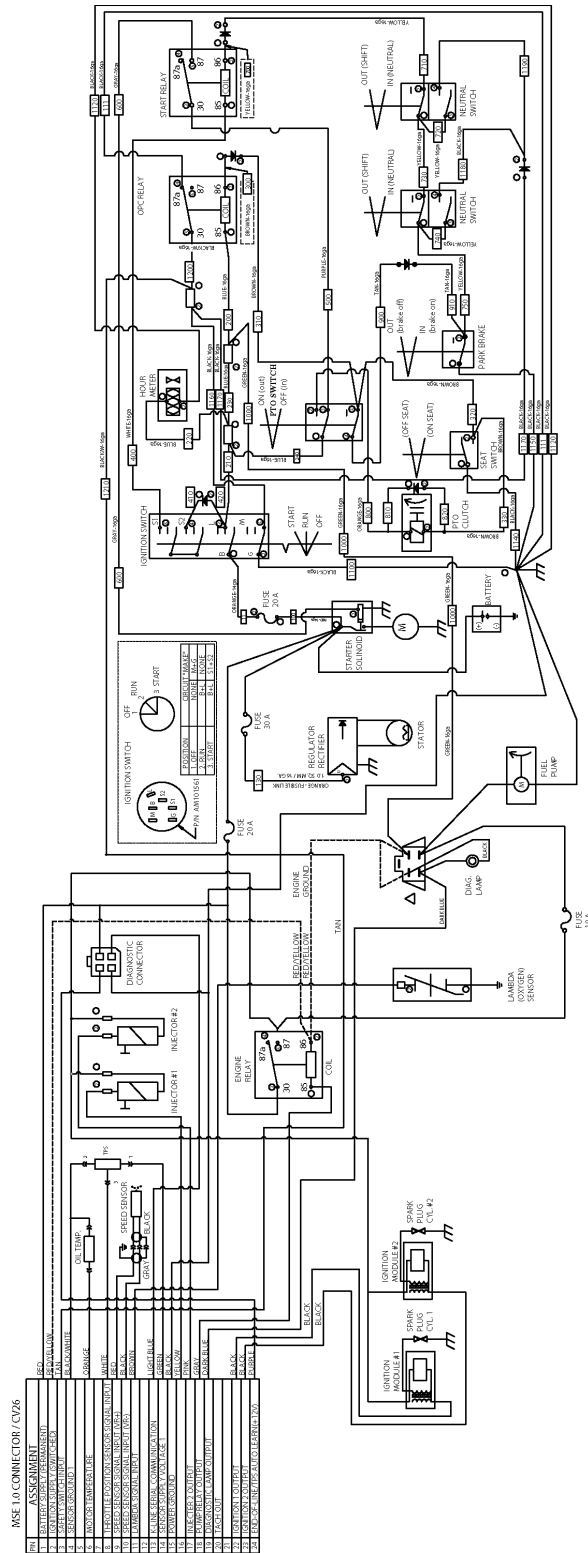

MX15345

SERVICE ELECTRICAL

Wiring Schematic - 28 HP Fuel Injected

Engine

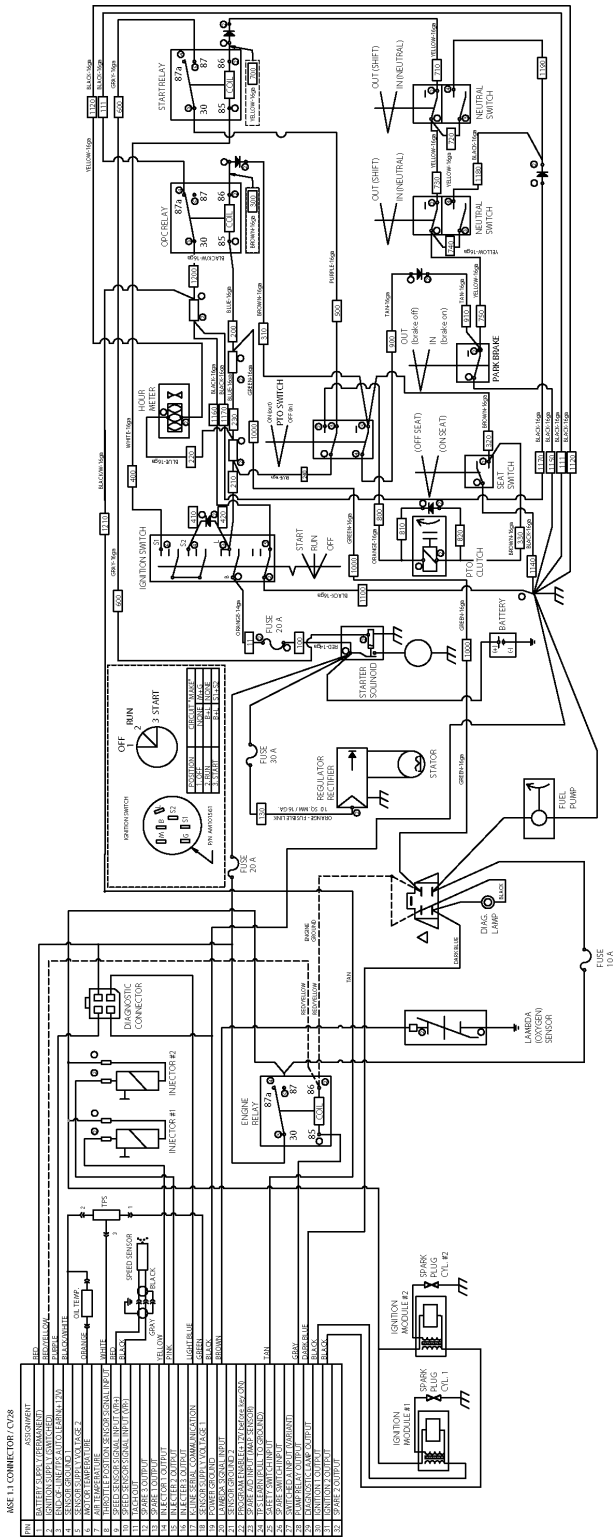

MX15356

SERVICE MISCELLANEOUS

Filling Fuel Tank

Use regular grade 87 octane unleaded fuel. (For gasoline engines only.)



CAUTION: Avoid injury! Fuel vapors are explosive and flammable:

- Shut engine off before filling fuel tank.
- Do not smoke while handling fuel.
- Keep fuel away from flames or sparks.
- Fill fuel tank outdoors or in well ventilated area.
- Clean up spilled fuel immediately.
- Use clean, approved non-metal container to prevent static electric discharge.
- Use clean, approved plastic funnel without screen or filter to prevent static electric discharge.

IMPORTANT: Avoid damage! Dirt and water in fuel can cause engine damage:

- Clean dirt and debris from the fuel tank opening.
- Use clean, fresh, stabilized fuel.
- Fill the fuel tank at the end of each day's operation to keep condensation out of the fuel tank.
- Use a non-metallic funnel with a plastic mesh strainer when filling the fuel tank or container.

NOTE: Capacity of fuel tank is 30.2 L (8 gal).

1. Stop engine and let it cool several minutes before adding fuel.
2. Remove any grass or debris from top of fuel tank.

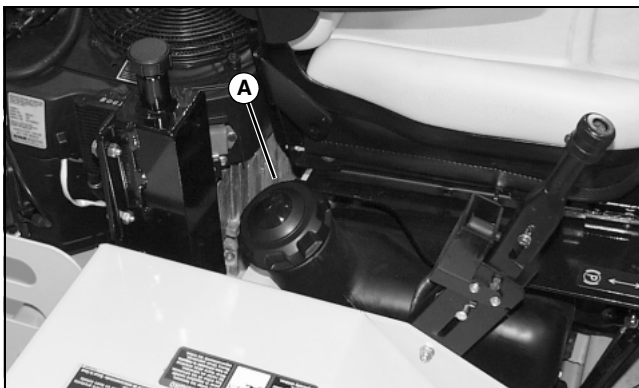

MX15309

3. Remove fuel tank cap (A).
4. Fill tank with fuel only to bottom of filler neck.
5. Install fuel tank cap.

Checking Tire Pressure



MIF



CAUTION: Avoid injury! Explosive separation of a tire and rim parts can cause serious injury or death:

- DO NOT attempt to mount a tire without the proper equipment and experience to perform the job.
- Always maintain the correct tire pressure. DO NOT inflate the tires above the recommended pressure. Never weld or heat a wheel and tire assembly. The heat can cause an increase in air pressure resulting in a tire explosion. Welding can structurally weaken or deform the wheel.
- When inflating tires, use a clip-on chuck and extension hose long enough to allow you to stand to one side and NOT in front of or over the tire assembly.
- Check tires for low pressure, cuts, bubbles, damaged rims or missing lug bolts and nuts.

1. Check tires for damage.
2. Check tire pressure with an accurate gauge.
3. Add air, if necessary:

Tire Size	Pressure
Front: 13 x 5.0-6	110-138 kPa (16-20 psi)
Rear - Chariot: 23 x 9.5-12	69-97 kPa (10-14 psi)
Rear - Chariot LX: 24 x 12-12	69-97 kPa (10-14 psi)

SERVICE MISCELLANEOUS

Remove and Install Rear Drive Wheels

Removing:

1. Park machine safely. (See Parking Safely in the Safety section.)

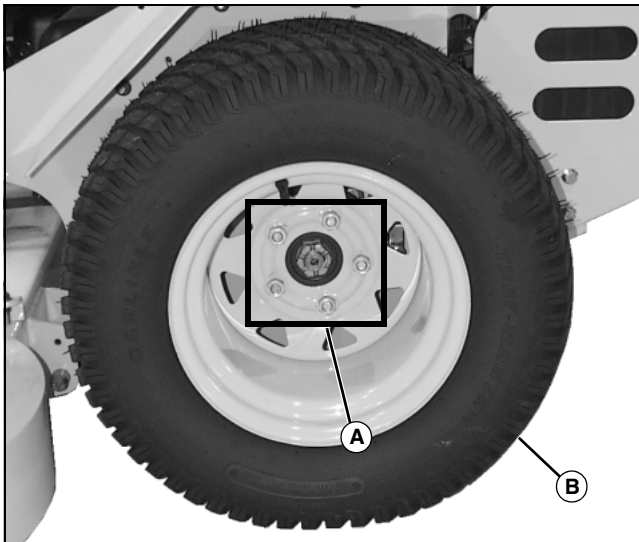

MX15322

2. Slightly loosen five wheel nuts (A).
3. Lift machine with a safe lifting device.
4. Remove wheel nuts.
5. Remove wheel and tire assembly (B).

Installing Rear Drive Wheels/Tightening Hardware:

1. Install new wheel and tire assembly.

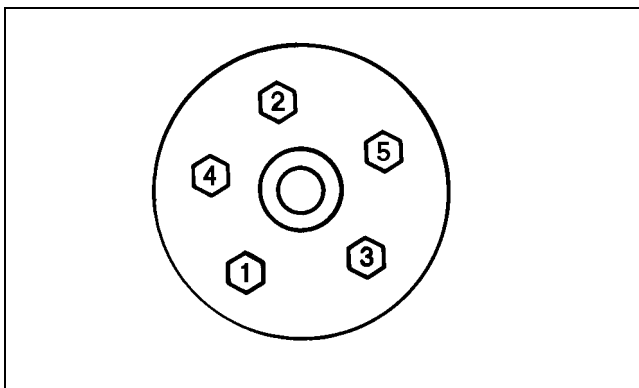

M77000

2. Install and tighten wheel nuts in numbered sequence shown for safe wheel installation. Tighten alternately until recommended torque value is reached.

- Tighten nuts to 100 N•m (75 lb-ft).

3. Lower machine.

Cleaning and Repairing Metal Surfaces

Cleaning:

Follow automotive practices to care for your machine's painted metal surfaces. Use a high-quality automotive wax regularly to maintain the factory look of your machine's painted surfaces.

Repairing Minor Scratches (Surface Scratch):

1. Clean area to be repaired thoroughly.

IMPORTANT: Avoid damage! Do not use rubbing compound on painted surfaces.

2. Use automotive polishing compound to remove surface scratches.
3. Apply wax to entire surface.

Repairing Deep Scratches (Bare Metal or Primer Showing):

1. Clean area to be repaired with rubbing alcohol or mineral spirits.
2. Use factory-matched colors available from your Great Dane dealer to fill scratches. Follow directions included on container for use and for drying.
3. Smooth out surface using an automotive polishing compound. Do not use power buffer.
4. Apply wax to surface.

TROUBLESHOOTING

Using Troubleshooting Chart

If you are experiencing a problem that is not listed in this chart, see your Great Dane servicing dealer for service.

When you have checked all the possible causes listed and you are still experiencing the problem, see your Great Dane servicing dealer.

Engine

If	Check
Engine Will Not Start or Is Hard to Start	Motion control levers not in the neutral detent (or neutral lock) position. Park brake lever unlocked. Key switch not in proper position. PTO engaged. Loose or corroded starter cable connections. Stale or improper fuel/fuel level. Plugged fuel filter. EFI Engines Only: Air in fuel line. Plugged air intake filter. Spark plug wire is loose or disconnected. Spark plug not gapped correctly. Blown 20-amp fuse (main power circuit). Carbureted Engines Only: Blown fusible link (charging circuit). Electrical problem - dead battery. Carbureted Engines Only: Choke adjusted incorrectly. See your Great Dane servicing dealer. EFI Engines Only: Blown 10-amp fuse (fuel pump circuit). EFI system problem - check EFI electrical system and connections. If problem continues, have system serviced by an authorized Kohler EFI servicing dealer.
Engine Will Not Slow Idle	Bent or kinked throttle cable. Carbureted Engines Only: Bent governor control. Carbureted Engines Only: Incorrect governor idle control. Carbureted Engines Only: Carburetion problems. See your Great Dane servicing dealer.

TROUBLESHOOTING

If	Check
Engine Runs Rough or Stalls	<p>Plugged fuel filter.</p> <p>Plugged air intake system.</p> <p>Fuel cap vent dirty.</p> <p>Stale or improper fuel/fuel level.</p> <p>Spark plug not gapped correctly.</p> <p>Replace spark plug.</p> <p>Carbureted Engines Only: Choke adjusted incorrectly. See your Great Dane servicing dealer.</p> <p>EFI system problem - check EFI electrical system and connections. If problem continues, have system serviced by an authorized Kohler EFI servicing dealer.</p>
Engine Knocks	<p>Engine oil level low.</p> <p>Reduce load. (Slower ground speed.)</p> <p>Fuel is bad. Fill tank with fresh fuel, correct octane.</p> <p>Idle speed too slow.</p> <p>EFI system problem - check EFI electrical system and connections. If problem continues, have system serviced by an authorized Kohler EFI servicing dealer.</p>
Engine Overheats	<p>Clean cooling fins.</p> <p>Low oil level.</p> <p>Do not operate at slow idle. Operate at full-throttle setting.</p> <p>Cooling air intake screen is dirty.</p> <p>Plugged air intake filter.</p> <p>Operating at too fast ground speed for conditions.</p>
Engine Lacks Power	<p>Plugged air intake system.</p> <p>Plugged fuel filter.</p> <p>Improper type of fuel. Drain tank and fill with correct fuel.</p> <p>Clean cooling fins to help prevent overheating.</p> <p>Replace spark plug.</p> <p>EFI system problem - check EFI electrical system and connections. If problem continues, have system serviced by an authorized Kohler EFI servicing dealer.</p>
Engine Uses Too Much Oil	<p>Find and correct oil leaks.</p> <p>Incorrect engine oil.</p> <p>Plugged oil filter.</p> <p>Plugged air intake filter.</p>

TROUBLESHOOTING

If	Check
Engine Backfires Through Muffler	<p>Throttle should be at low idle for several seconds before turning off machine.</p> <p>Leaking/damaged exhaust manifold gasket.</p> <p>EFI system problem - check EFI electrical system and connections. If problem continues, have system serviced by an authorized Kohler EFI servicing dealer.</p>
High Fuel Consumption	<p>Improper type of fuel.</p> <p>Plugged air intake system.</p> <p>Operating at too fast ground speed for conditions.</p> <p>Improper valve clearance. See your Great Dane servicing dealer.</p> <p>Restricted air intake system.</p> <p>EFI system problem - check EFI electrical system and connections. If problem continues, have system serviced by an authorized Kohler EFI servicing dealer.</p>

Electrical System

If	Check
Starter Will Not Work	<p>Dead battery.</p> <p>Blown 20-amp fuse (main power circuit).</p> <p>Blown fusible link (charging circuit).</p> <p>Loose or corroded battery or ground connections.</p> <p>Loose or corroded starter cable connections.</p> <p>Neutral start switches faulty or not adjusted properly. See your Great Dane servicing dealer.</p> <p>Key switch or starter faulty. See your Great Dane servicing dealer.</p> <p>PTO engaged.</p> <p>Motion control levers and park brake lever not in proper position.</p>
Battery Will Not Charge	<p>Loose or corroded battery or ground connections.</p> <p>Blown fusible link (charging circuit).</p> <p>Battery cables and terminals are dirty.</p> <p>Dead cell in battery.</p>
PTO Clutch Does Not Engage	<p>Blown 20-amp fuse (main power circuit).</p> <p>Faulty PTO switch.</p> <p>Faulty PTO clutch.</p> <p>Loose PTO clutch connections.</p>

TROUBLESHOOTING

If	Check
Starter Turns Slowly	Loose or corroded battery or ground connections. Low battery power - charge battery. Engine oil viscosity too heavy. Hydraulic pump linkages failed and are engaged.

Machine

If	Check
Excessive Machine Vibration	Engine speed too slow.
Machine Will Not Move With Engine Running	Park brake locked. Transmission hydraulic oil level low. Transmission oil cold - allow engine to warm. Traction drive belt slipping. Hydraulic pump free-wheel valves open. Traction drive belt damaged or worn. Hydrostatic pump and/or wheel motor problems. See your Great Dane servicing dealer.
Machine Creeps With Engine Running and Motion Control Levers in a Neutral Position	Needs shift control linkage adjustment.

Park Brake

If	Check
Park Brake Not Working Correctly	Brakes out of adjustment - adjust linkage. Brake drums wet. Worn brake shoes. Brake cables damaged.

Steering

If	Check
Steering Not Working	Park brake locked. Hydraulic pump free-wheel valves partially open. Improper tire Inflation. Hydrostatic transmission oil low. Traction drive belt slipping. Traction drive belt damaged or worn.
Machine Will Not Follow a Straight Path	Steering tracking out of adjustment.

TROUBLESHOOTING

If	Check
Machine Moves to the Left or Right With Engine Running and Transmission in Neutral	Pump linkage (neutral position) out of adjustment.

Mower Deck

If	Check
Discharge Chute Plugged	<p>Grass is wet - mow grass only when dry.</p> <p>Raise cutting height.</p> <p>Mow at full throttle.</p> <p>Ground speed too fast for conditions.</p> <p>Correct installation of deck drive belt.</p>
Mower Deck Vibrates	<p>Run engine at full throttle.</p> <p>Loose hardware.</p> <p>Check/replace mower deck drive belt.</p> <p>Check/replace spindle drive belt (72-inch mower deck).</p> <p>Blades bolts are loose.</p> <p>Blades are bent or worn.</p> <p>Sharpen and balance blades.</p> <p>Remove belt shields and check for debris on sheaves.</p> <p>Check sheaves for proper alignment or damage. See your Great Dane servicing dealer.</p>
Mower Blades Do Not Engage	<p>Mower deck drive belt slipping or broken.</p> <p>Spindle drive belt slipping or broken (72-inch mower deck).</p> <p>Mower deck belt tension spring not installed or broken.</p> <p>PTO switch failure.</p> <p>20-amp fuse is blown (main power circuit).</p> <p>Loose electrical connections.</p> <p>Faulty PTO clutch.</p>
Mower Mows Unevenly	<p>Mower deck not properly leveled.</p> <p>Ground speed too fast for conditions.</p> <p>Run engine at full throttle.</p> <p>Reduce ground speed when making turns.</p> <p>Blades are bent or worn.</p> <p>Sharpen or replace blades.</p> <p>Change mowing pattern.</p> <p>Check tire pressure.</p>

STORAGE

Storing Safety



CAUTION: Avoid injury! Fuel vapors are explosive and flammable. Engine exhaust fumes contain carbon monoxide and can cause serious illness or death:

- Run the engine only long enough to move the machine to or from storage.
- Do not store vehicle with fuel in the tank inside a building where fumes may reach an open flame or spark.
- Allow the engine to cool before storing the machine in any enclosure.

Preparing Machine for Storage

1. Repair any worn or damaged parts. Replace parts if necessary. Tighten loose hardware.
2. Repair scratched or chipped metal surfaces to prevent rust.
3. Clean under the deck and remove grass and debris from inside chute.
4. Wash the machine and apply wax to metal surfaces.
5. Run machine for five minutes to dry belts and pulleys.
6. Apply light coat of engine oil to pivot and wear points to prevent rust.

Preparing Fuel and Engine for Storage

Fuel:

If you have been using "Stabilized Fuel", add stabilized fuel to tank until the tank is full.

NOTE: Filling the fuel tank reduces the amount of air in the fuel tank and helps reduce deterioration of fuel.

If you are not using "Stabilized Fuel":

1. Park machine safely in a well-ventilated area.

NOTE: Try to anticipate the last time the machine will be used for the season so very little fuel is left in the fuel tank.

2. Turn on engine and allow to run until it runs out of fuel.
3. Turn key to off position.
4. Mix fresh fuel and fuel stabilizer in separate container. Follow stabilizer instructions for mixing.
5. Fill fuel tank with stabilized fuel.
6. Run engine for a few minutes to allow fuel mixture to circulate through fuel system.

Engine:

Engine storage procedure should be used when vehicle is not to be used for longer than 60 days.

1. Change engine oil and filter while engine is warm.
2. Service air filter if necessary.
3. Clean debris from engine air intake screen.
4. Remove spark plugs. Put 30 mL (1 oz.) of clean engine oil in cylinders.
5. Crank the engine five or six times to allow oil to be distributed.
6. Install spark plugs.
7. Clean the engine and engine compartment.
8. Remove battery.
9. Clean the battery and battery posts.
10. Store the battery in a cool, dry place where it will not freeze.

NOTE: The stored battery should be recharged every 90 days.

11. Charge the battery.
12. Store the machine in a dry, protected place. If machine is stored outside, put a waterproof cover over it.

Removing Machine From Storage

1. Check tire pressure.
2. Check engine oil level.
3. Charge battery if necessary.
4. Install battery.
5. Check spark plug gap. Install and tighten plugs to specified torque.
6. Lubricate all grease points.
7. Run the engine 5 minutes without the mower or any attachments running to allow oil to be distributed throughout engine.
8. Be sure all shields and guards or deflectors are in place.

ASSEMBLY

Bag of Parts

Qty.	Description
1	Key
1	Operator's Manual
1	PDR Check List

Prepare for Assembly

- Remove machine from the shipping crate:
 - Remove box containing operator seat.
 - Cut plastic tie straps fastening the front wheels to the shipping crate.
 - Cut plastic tie straps holding the discharge chute up.
 - Cut plastic tie straps securing the motion control levers to the machine.

Check Hydraulic Oil Level

IMPORTANT: Avoid damage! Check all fluid levels before attempting to start the machine. Machine should be parked on a hard, level surface with the key switch in the STOP position.

1. Park machine safely. (See Parking Safely in the Safety section.)

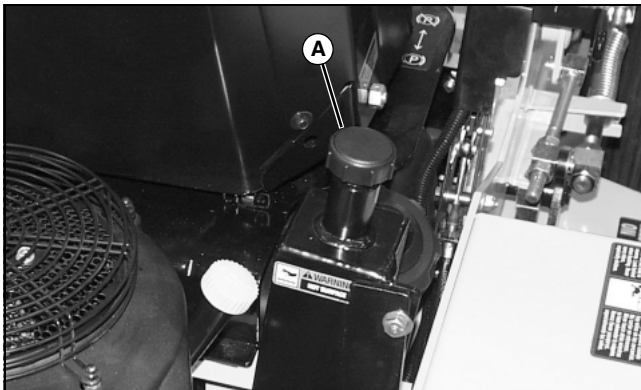

MX15294

2. Unscrew and remove hydraulic reservoir cap/dipstick (A) from hydraulic oil reservoir.
3. Wipe dipstick with a clean cloth.
4. Install dipstick and allow the cap to rest on the end of the tube. Do not tighten the cap.
5. Remove dipstick and check oil level. Oil level should be at top mark on dipstick.
6. If necessary, add oil through oil reservoir filler neck.

7. Install cap on filler neck.

Check Engine Oil Level

Remove dipstick from tube by unscrewing it. Wipe it clean.

8. Install dipstick and allow the cap to rest on the end of the tube. Do not tighten the cap.

9. Remove dipstick. Check oil level on dipstick; oil level should be between the ADD and FULL marks.

- If oil is low, add oil to bring oil level no higher than the FULL mark on dipstick.
- If oil level is above the FULL mark, drain to proper level.

10. Install and tighten dipstick.

Check Tire Pressure



CAUTION: Avoid injury! Explosive separation of a tire and rim parts can cause serious injury or death:

- **DO NOT** attempt to mount a tire without the proper equipment and experience to perform the job.
- **Always** maintain the correct tire pressure. **DO NOT** inflate the tires above the recommended pressure. **Never** weld or heat a wheel and tire assembly. The heat can cause an increase in air pressure resulting in a tire explosion. **Welding** can structurally weaken or deform the wheel.
- **When** inflating tires, use a clip-on chuck and extension hose long enough to allow you to stand to one side and **NOT** in front of or over the tire assembly.
- **Check** tires for low pressure, cuts, bubbles, damaged rims or missing lug bolts and nuts.

1. Check tires for damage.
2. Check tire pressure with an accurate gauge.
3. Check that tires have correct pressure. Add air, if necessary:

Tire Size	Pressure
Front: 13 x 5.0-6	110-138 kPa (16-20 psi)
Rear - Chariot: 23 x 9.5-12	69-97 kPa (10-14 psi)
Rear - Chariot LX: 24 x 12-12	69-97 kPa (10-14 psi)

ASSEMBLY

Install Motion Control Levers



MX15343

1. Remove hardware from control arms.

NOTE: The control lever mounting brackets have six holes. The levers can be installed in the top four holes, or for a lower lever position, install the levers in the lower four holes.

2. Align motion control levers (A) with control arms. Install hardware and tighten.
3. Check motion control lever alignment.
 - Move both motion control levers forward.

Install Seat

1. Remove protective covers from seat screws.

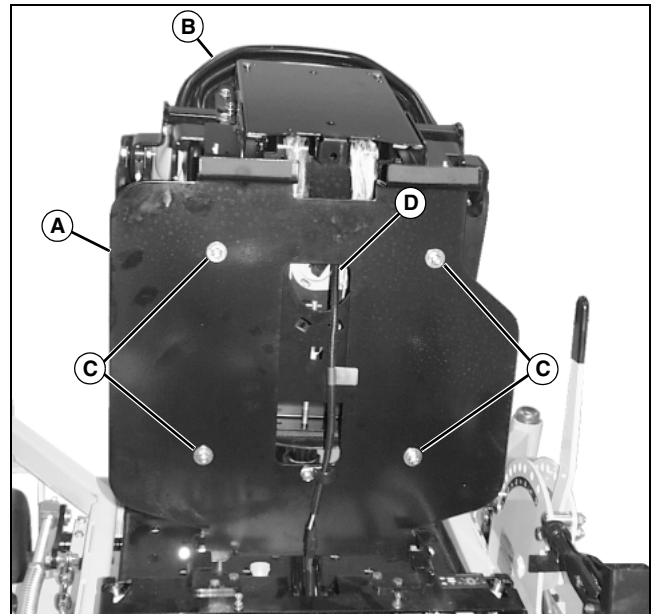

MX15344

2. Pivot seat frame (A) forward until it rests on the hinge stops.

NOTE: The seat mounting hardware is attached to the seat plate with tie straps.

3. Install seat (B) to the seat frame, using four 5/16-18 locknuts and heavy flat washers (C). Tighten locknuts to 27 N•m (20 lb-ft).
4. Connect wire harness to seat safety switch (D).

Lubricate Machine

Lubricate all moving parts before operating the machine. See Lubrication Points in the Service Lubrication section.

Check Mower Deck Level

The mower deck is assembled and adjusted at the factory. After machine is completely assembled, check the mower front-to-rear and side-to-side deck level.

Check Safety System

For a complete checkout procedure of the safety interlock system, see Testing the Safety Interlock System in the Operating section.

ASSEMBLY

Initial Adjustments



CAUTION: Avoid injury! Clear area of bystanders before performing this service procedure.

1. Check free-wheel valves on both pump assemblies to make sure that the valves are closed. Tighten valves to 108-163 N•m (80-120 lb-ft).
2. Raise the rear of the machine until the drive wheels are off the ground. Support the machine with jackstands.



CAUTION: Avoid injury! Engine exhaust fumes contain carbon monoxide and can cause serious illness or death.

Move the vehicle to an outside area before running the engine.

Do not run an engine in an enclosed area without adequate ventilation.

- **Connect a pipe extension to the engine exhaust pipe to direct the exhaust fumes out of the area.**
- **Allow fresh outside air into the work area to clear the exhaust fumes out.**

3. Start and run the engine until it reaches normal operating temperature.
4. Move control levers to the forward position and observe drive wheel rotation; the drive wheels should rotate in the correct direction.
5. Move the control levers to the reverse position and observe drive wheel rotation; the drive wheels should rotate in the correct direction.
6. Move PTO clutch switch to on position; mower clutch should engage. Run blades for several minutes.
7. Move PTO clutch switch to off position and shut the engine off.
8. Check all belts for proper tension.
9. Start the engine and test drive the machine in an open area. Drive the machine forward; if the machine drifts to the right or left, adjust the transmission control linkage.

SPECIFICATIONS

Engine

NOTE: See engine manufacturer's owner's manual provided with your machine for engine specifications.

Battery

Voltage	12 volt
CCA	340 amp
Reserve Capacity	90 minutes
BCI Group Size	51

Tires - Chariot

Front	13 x 5.0-6
Rear	23 x 9.50-12
Inflation Front (Maximum)	110-138 kPa (16-20 psi)
Inflation Rear (Maximum)	69-97 kPa (10-14 psi)
Wheel Nut Torque	100 N•m (75 lb-ft)

Tires - Chariot LX

Front	13 x 5.0-6
Rear	24 x 12-12
Inflation Front (Maximum)	110-138 kPa (16-20 psi)
Inflation Rear (Maximum)	69-97 kPa (10-14 psi)
Wheel Nut Torque	100 N•m (75 lb-ft)

Capacities

Fuel Tank	30.2 L (8 gal)
Hydraulic System	3.54 L (3.75 qt)

Net Weight - Chariot (With Mower Deck and Without Fuel)

17-hp Kawasaki Engine/48-in. Deck	479 kg (1055 lb)
19-hp Kawasaki Engine/48-in. Deck	479 kg (1055 lb)
23-hp Kawasaki Engine/52-in. Deck	489 kg (1079 lb)
25-hp Kawasaki Engine/52-in. Deck	489 kg (1079 lb)
25-hp Kohler Engine/52-in. Deck	489 kg (1079 lb)
25-hp Kawasaki Engine/61-in. Deck	489 kg (1079 lb)
25-hp Kohler Engine/61-in. Deck	489 kg (1079 lb)

Net Weight - Chariot LX (With Mower Deck and Without Fuel)

25-hp Kawasaki Engine/61-in. Deck	501 kg (1104 lb)
25-hp Kohler Engine/61-in. Deck	501 kg (1104 lb)
26-hp Kohler Engine/61-in. Deck	501 kg (1104 lb)
27-hp Kohler Engine/61-in. Deck	500 kg (1103 lb)
28-hp Kohler Engine/61-in. Deck	501 kg (1104 lb)
27-hp Kohler Engine/72-in. Deck	545 kg (1202 lb)
28-hp Kohler Engine/72-in. Deck	545 kg (1202 lb)

Travel Speeds

Forward	0-14 km/h (0-9 mph)
Reverse	0-8 km/h (0-5 mph)

Dimensions - Chariot

Wheel Base	1.10 m (43.375 in.)
Track Width	1.21 m (47.5 in.)
Overall Height	1.09 m (42.75 in.)
Overall Length (with Kawasaki Engines)	1.92 m (75.5 in.)
Overall Length (with Kohler Engines)	1.97 m (77.75 in.)
Overall Width (with 48-in. Deck)	1.50 m (59 in.)
Overall Width (with 52-in. Deck)	1.63 m (64 in.)
Overall Width (with 61-in. Deck)	1.86 m (73.375 in.)

Dimensions - Chariot LX

Wheel Base	1.27 m (49.875 in.)
Track Width	1.35 m (53 in.)
Overall Height	1.22 m (48 in.)
Overall Length (with Kawasaki Engines)	2.00 m (78.75 in.)
Overall Length (with Kohler Engines)	2.06 m (81 in.)
Overall Width (with 61-in. Deck)	1.86 m (73.375 in.)
Overall Width (with 72-in. Deck)	2.13 m (83.75 in.)

48-Inch Mower Deck

Mower Type	Mulch, Bag or Side Discharge
Cutting Blades	3
Blade Bolt Torque	81 N•m (60 lb-ft)
Cutting Width	1.22 m (48 in.)
Cutting Height (approximate)	25 to 127 mm (1 to 5 in.)

SPECIFICATIONS

Height Adjustment Increments 13 mm (1/2 in.)

52-Inch Mower Deck

Mower Type Mulch, Bag or Side Discharge
Cutting Blades 3
Blade Bolt Torque 81 N•m (60 lb-ft)
Cutting Width 1.32 m (52 in.)
Cutting Height (approximate) . . . 25 to 127 mm (1 to 5 in.)
Height Adjustment Increments 13 mm (1/2 in.)

61-Inch Mower Deck

Mower Type Mulch, Bag or Side Discharge
Cutting Blades 3
Blade Bolt Torque 81 N•m (60 lb-ft)
Cutting Width 1.55 m (61 in.)
Cutting Height (approximate) . . . 25 to 127 mm (1 to 5 in.)
Height Adjustment Increments 13 mm (1/2 in.)

72-Inch Mower Deck

Mower Type Mulch, Bag or Side Discharge
Cutting Blades 3
Blade Bolt Torque 81 N•m (60 lb-ft)
Cutting Width 1.83 m (72 in.)
Cutting Height (approximate) . . . 25 to 127 mm (1 to 5 in.)
Height Adjustment Increments . 13 mm (1/2 in.) increments

(Specifications and design subject to change without notice.)

INDEX

A

Air Cleaner Elements, Checking and Cleaning	27
Assembly	65

B

Balancing Blades	48
Battery, Cleaning	51
Battery, Remove and Install	51
Battery, Specifications	68
Battery, Using Booster	52
Belt Shields, Removing and Installing Mower Deck	41
Blades, Balance	48
Blades, Check and Replace Mower	47
Blades, Sharpen	48
Brake, Testing Park	11

C

Carburetor, Adjusting	28
Certification	3
Chariot	-1
Chart, Service Interval	23
Choke, Using	15
Controls, Miscellaneous	10
Cutting Height, Adjusting Mower Deck	12

D

Daily Operating Checklist	10
Deck Anti-Scalp Wheels, Adjusting Mower	13
Deck Belt Shields, Removing and Installing Mower	41
Deck Cutting Height, Adjusting Mower	12
Deck Level, Check Mower	66
Deck Lift Assist Spring, Adjust Tension	44
Dimensions, Chariot	68
Dimensions, Chariot LX	68

E

Electrical System, Troubleshooting	61
Emission Compliance Period	3
Emission Control System Certification Label	3
Engine Air Intake Screen and Fan, Cleaning	27
Engine Oil and Filter, Changing	26
Engine Warranty Maintenance Statement	26
Engine and Fuel Storage, Preparing	64
Engine, Checking Oil Level	26
Engine, Specifications	68
Engine, Starting	18
Engine, Stopping	19
Engine, Troubleshooting	59
Engine-to-Deck Belt, Check/Adjust Tension, 72-In.	44
Engine-to-Deck Drive Belt, Remove/Install, 72-In.	46

F

Filter, Changing Engine Oil and	26
Front Caster Spindle Bearings, Adjust	38

Front Caster Spindle Bearings, Service	38
Front Caster Wheels, Remove and Install	37
Front Caster Wheels, Service Bearings, Chariot	37
Front Caster Wheels, Service Bearings, Chariot LX	37
Fuel Filter, Replacing Fuel Injected Engines	28
Fuel Filter, Replacing, Carbureted Engines	28
Fuel Injectors, Prime	29
Fuel Safety	9
Fuel Tank, Filling	57
Fuse, Replace	
Carbureted Engines	52
Fuses, Replacing - Carbureted Engines	52
Fuses, Replacing - Fuel Injected Engines	52

G

Grease	24
--------------	----

H

Hourmeter, Using	15
Hydraulic Oil	31
Hydraulic Oil, Change	31
Hydraulic Oil, Check Level	31
Hydraulic Pump Free-Wheel Valves, Using	20
Hydraulic Pump, Clean Cooling Fins	32
Hydraulic System, Hose Routing	35
Hydraulic System, Schematic	36

K

Key Switch, Using	14
-------------------------	----

L

Labels, Safety	1
Linkages, Check and Adjust Motion Control	33
Lubrication Points	24

M

Machine, Transporting	20
Metal Surfaces, Repairing and Cleaning	58
Motion Control Levers, Check and Align	39
Motion Control Levers, Installing	66
Motion Control Levers, Using	15
Motion Control Linkages, Check and Adjust	33
Mower Blades, Balance	48
Mower Blades, Check and Replace	47
Mower Blades, Sharpen	48
Mower Deck Anti-Scalp Wheels, Adjusting	13
Mower Deck Belt Shields, Removing and Installing	41
Mower Deck Cutting Height, Adjusting	12
Mower Deck Drive Belt, Check/Adjust Tension, 48-In. ...	44
Mower Deck Drive Belt, Check/Adjust Tension, 52-In. ...	44
Mower Deck Drive Belt, Check/Adjust Tension, 61-In. ...	44
Mower Deck Drive Belt, Remove/Install, 48-In	45
Mower Deck Drive Belt, Remove/Install, 52-In.	45
Mower Deck Drive Belt, Remove/Install, 61-In.	45
Mower Deck Foot Plate, Removing and Installing	41
Mower Deck Level, Check	66
Mower Deck, Level	42

INDEX

Mower Deck, Troubleshooting	63	Storage, Removing Machine	64
Mower, Dismounting to Inspect	21	Storing Safety	64
Mower, Engaging	19	T	
Mowing Tips	20	Testing Park Brake	11
Mowing Travel Speeds	21	Testing Safety Systems	10
N		Throttle Lever, Using	15
Neutral Start Switch, Test	11	Tire Pressure, Checking	57
O		Tire Specifications, Chariot	68
Oil Level, Checking Engine	26	Tire Specifications, Chariot LX	68
Oil and Filter, Changing Engine	26	Traction Drive Belt, Remove and Install	32
Oil, Engine	26	Transporting Machine	20
Oil, Hydraulic	31	Travel Speeds, Mowing	21
Operating Checklist, Daily	10	Troubleshooting, Electrical	61
P		Troubleshooting, Engines	59
PTO Clutch, Burnishing	53	Troubleshooting, Kolher Fuel Injection System	29
PTO Switch, Test	11	Troubleshooting, Mower Deck	63
PTO Switch, Using	14	Troubleshooting, Park Brake	62
Park Brake Switch, Test	11	Troubleshooting, Steering	62
Park Brake, Adjust	40	V	
Park Brake, Testing	11	Valves, Using Hydraulic Pump Free-Wheel	20
Park Brake, Troubleshooting	62	W	
Park Brake, Using	13	Warranty Maintenance Statement, Engine	26
Part Numbers, Replacement	22	Weights, Chariot	68
Parts, Replacement	22	Weights, Chariot LX	68
Plastic and Painted Surfaces, Avoid Damage	21	Wheels	
R		Remove and Install Rear Drive	58
Rear Drive Wheels, Remove and Install	58	Wheels, Adjusting Mower Deck Anti-Scalp	13
S		Wheels, Remove and Install Front Caster	37
Safety Systems, Testing	10	Wiring Schematic, Carbureted Engines	54
Safety, Tire	8	Wiring Schematic, Fuel Injected Engine (26 HP)	55
Safety-Alert Symbol	1	Wiring Schematic, Fuel Injected Engine (28 HP)	56
Seat Switch, Test	11		
Seat, Adjusting	12		
Seat, Install	66		
Seat, Raise and Lower	12		
Service Interval Chart	23		
Service Record	71		
Service, Lubrication	24		
Spark Arrestor, Using	5		
Spark Plugs, Checking	28		
Specifications	68		
Specifications, 48-Inch Mower Deck	68		
Specifications, 52-Inch Mower Deck	69		
Specifications, 61-Inch Mower Deck	69		
Specifications, 72-Inch Mower Deck	69		
Spindle Bearings, Replace - 72-Inch Mower Deck	49		
Spindle Bearings, Replace, 48-, 52- and 61-In. Decks ..	48		
Spindle Drive Belt, Check and Adjust Tension	45, 47		
Spindle Drive Belt, Remove and Install	47		
Steering, Troubleshooting	62		
Storage, Preparing Fuel and Engine	64		
Storage, Preparing Machine	64		

Free Manuals Download Website

<http://myh66.com>

<http://usermanuals.us>

<http://www.somanuals.com>

<http://www.4manuals.cc>

<http://www.manual-lib.com>

<http://www.404manual.com>

<http://www.luxmanual.com>

<http://aubethermostatmanual.com>

Golf course search by state

<http://golfingnear.com>

Email search by domain

<http://emailbydomain.com>

Auto manuals search

<http://auto.somanuals.com>

TV manuals search

<http://tv.somanuals.com>