

Installation, Operation and Maintenance Manual

Please read and save these instructions. Read carefully before attempting to assemble, install, operate or maintain the product described. Protect yourself and others by observing all safety information. Failure to comply with instructions could result in personal injury and/or property damage! Retain instructions for future reference.

Model LFC

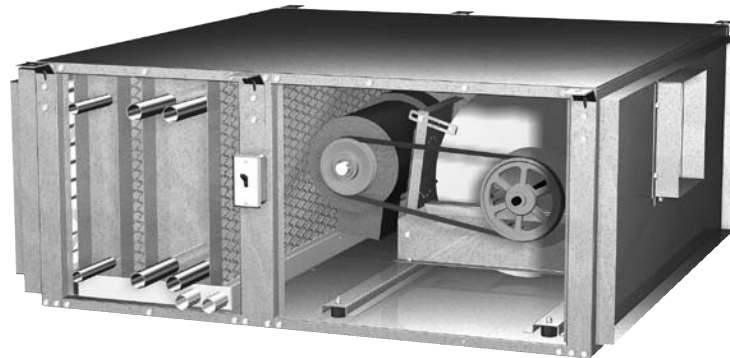

General Safety Information

Only qualified personnel should install this unit. Personnel should have a clear understanding of these instructions and should be aware of general safety precautions. Improper installation can result in electric shock, possible injury due to coming in contact with moving parts, as well as other potential hazards. Other considerations may be required if high winds or seismic activity are present. If more information is needed, contact a licensed professional engineer before moving forward.

1. Follow all local electrical and safety codes, as well as the National Electrical Code (NEC), the National Fire Protection Agency (NFPA), where applicable. Follow the Canadian Electric Code (CEC) in Canada.

DANGER

Always disconnect power before working on or near a unit. Lock and tag the disconnect switch or breaker to prevent accidental power up.

CAUTION

When servicing the unit, motor may be hot enough to cause pain or injury. Allow motor to cool before servicing.

2. The rotation of the wheel is critical. It must be free to rotate without striking or rubbing any stationary objects.
3. Motor must be securely and adequately grounded.
4. Do not spin fan wheel faster than the maximum cataloged fan rpm. Adjustments to fan speed significantly affects motor load. If the fan RPM is changed, the motor current should be checked to make sure it is not exceeding the motor nameplate amps.
5. Do not allow the power cable to kink or come in contact with oil, grease, hot surfaces, or chemicals. Replace cord immediately if damaged.
6. Verify that the power source is compatible with the equipment.
7. Never open blower access doors while the fan is running.

Receiving

Upon receiving the product, check to make sure all items are accounted for by referencing the bill of lading to ensure all items were received. Inspect each crate for shipping damage before accepting delivery. Notify the carrier if any damage is noticed. The carrier will make notification on the delivery receipt acknowledging any damage to the product. All damage should be noted on all the copies of the bill of lading which is countersigned by the delivering carrier. A Carrier Inspection Report should be filled out by the carrier upon arrival and reported to the Traffic Department. If damaged upon arrival, file claim with carrier. Any physical damage to the unit after acceptance is not the responsibility of Greenheck Fan Corporation.

Unpacking

Verify that all required parts and the correct quantity of each item have been received. If any items are missing, report shortages to your local representative to arrange for obtaining missing parts. Sometimes it is not possible that all items for the unit be shipped together due to availability of transportation and truck space. Confirmation of shipment(s) must be limited to only items on the bill of lading.

Handling

Units are to be rigged and moved by the lifting brackets provided or by the skid when a forklift is used. Location of brackets varies by model and size. Handle in such a manner as to keep from scratching or chipping the coating. Damaged finish may reduce ability of unit to resist corrosion.

Storage

Units are protected against damage during shipment. If the unit cannot be installed and operated immediately, precautions need to be taken to prevent deterioration of the unit during storage. The user assumes responsibility of the unit and accessories while in storage. The manufacturer will not be responsible for damage during storage. These suggestions are provided solely as a convenience to the user.

INDOOR — The ideal environment for the storage of units and accessories is indoors, above grade, in a low humidity atmosphere which is sealed to prevent the entry of blowing dust, rain, or snow. Temperatures should be evenly maintained between 30°F (-1°C) and 110°F (43°C) (wide temperature swings may cause condensation and “sweating” of metal parts). All accessories must be stored indoors in a clean, dry atmosphere.

Remove any accumulations of dirt, water, ice, or snow and wipe dry before moving to indoor storage. To avoid “sweating” of metal parts allow cold parts to reach room temperature. To dry parts and packages use a portable electric heater to get rid of any moisture build up. Leave coverings loose to permit air circulation and to allow for periodic inspection.

The unit should be stored at least 3½ in. (89 mm) off the floor on wooden blocks covered with moisture proof paper or polyethylene sheathing. Aisles between parts and along all walls should be provided to permit air circulation and space for inspection.

Inspection and Maintenance during Storage

While in storage, inspect fans once per month. Keep a record of inspection and maintenance performed.

If moisture or dirt accumulations are found on parts, the source should be located and eliminated. At each inspection, rotate the fan wheel by hand ten to fifteen revolutions to distribute lubricant on motor. Every three months, the fan motor should be energized. If paint deterioration begins, consideration should be given to touch-up or repainting. Fans with special coatings may require special techniques for touch-up or repair.

Machined parts coated with rust preventive should be restored to good condition promptly if signs of rust occur. Immediately remove the original rust preventive coating with petroleum solvent and clean with lint-free cloths. Polish any remaining rust from surface with crocus cloth or fine emery paper and oil. Do not destroy the continuity of the surfaces. Wipe thoroughly clean with Tectyl® 506 (Ashland Inc.) or the equivalent. For hard to reach internal surfaces or for occasional use, consider using Tectyl® 511M Rust Preventive or WD-40® or the equivalent.

REMOVING FROM STORAGE — As units are removed from storage to be installed in their final location, they should be protected and maintained in a similar fashion, until the equipment goes into operation.

Prior to installing the unit and system components, inspect the unit assembly to make sure it is in working order.

1. Check all fasteners, set screws on the fan, wheel, bearings, drive, motor base, and accessories for tightness.
2. Rotate the fan wheel(s) by hand and assure no parts are rubbing.

Service Clearance

Units require service clearance for:

- filter replacement
- coil and drain pan inspection - cleaning, and replacement
- motor and drive inspection - maintenance and replacement

Access panels are provided for inspection and cleaning of unit components. Allow service clearance of 26 inches for removal of filters. Allow a service clearance equal to the unit width for removal of coils and drain pan.

Table of Contents

Installation

- Unit Layout3
- Lifting / Hanging Instructions..... 3
- Dimensions / Weights..... 4
- Filter Sizes / Quantity 4
- Coil Dimensions5-6

Start-Up

- System Start-Up 7

Troubleshooting

- Blower 8
- Motor Overamps 8
- Insufficient / Too Much Airflow..... 8
- Excessive Noise or Vibration 8

Start-Up

- Coil Module9-10
- Drain Pan / Drain Trap 10

Maintenance

- Fan 11
- Coil..... 12
- Drain Pan..... 12

Reference

- Start-Up Documentation..... 12
- Maintenance Log13-15
- WarrantyBackcover

Unit Layout

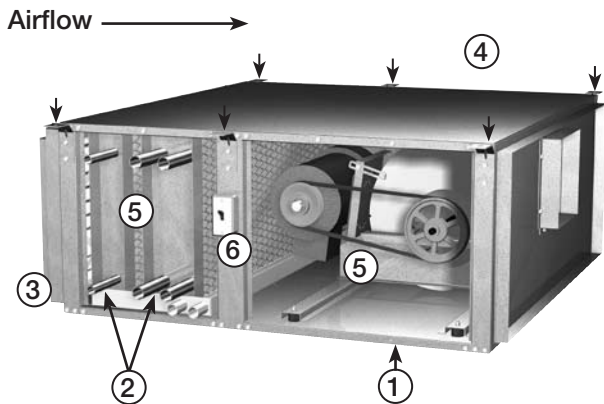

1. Fan Section
2. Coil Section
 - Chilled Water
 - Hot Water
 - DX Coils
 - Steam Coils
3. Inlet Filter
Vertical inlet filter with quarter-turn fasteners
4. Lifting Lugs/Hanging Brackets
Six (6) lifting lugs for each unit
5. Side Access Panels
Right and left access to each unit. (Image shows panels removed).
6. 1¼ inch knockout is provided for the recommended electrical wiring penetration or disconnect switch.

Lifting Instructions

Greenheck's Low-Profile Fan Coil (LFC) should be lifted by the factory supplied lifting lugs or frame rails and a spreader bar (by others) to prevent damage from occurring to the equipment (see Figure 1). Avoid twisting or uneven lifting of equipment. Do not lift equipment by coil connections or headers. The unit must remain upright during lifting. All access doors and panels must be closed during lifting to avoid damage.

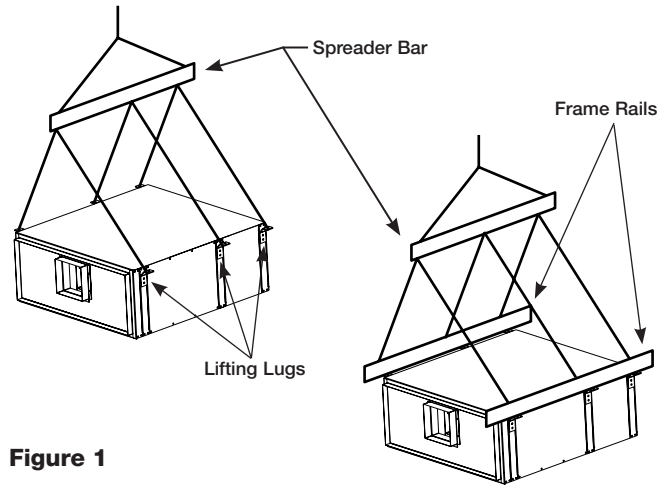

Figure 1

Hanging Instructions

The LFC should be hung by the factory supplied lifting lugs or field supplied frame rails as shown respectively in Figures 2 and 3. All hanging brackets must be used to mount the unit. The LFC is available with both external neoprene and spring isolation options.

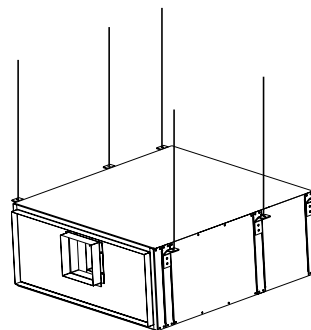

Figure 2

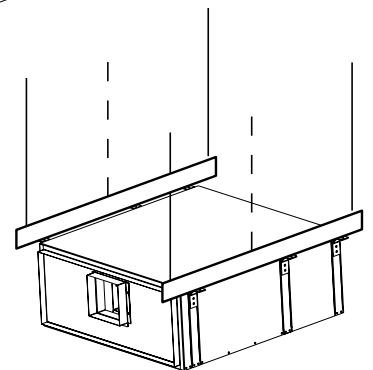
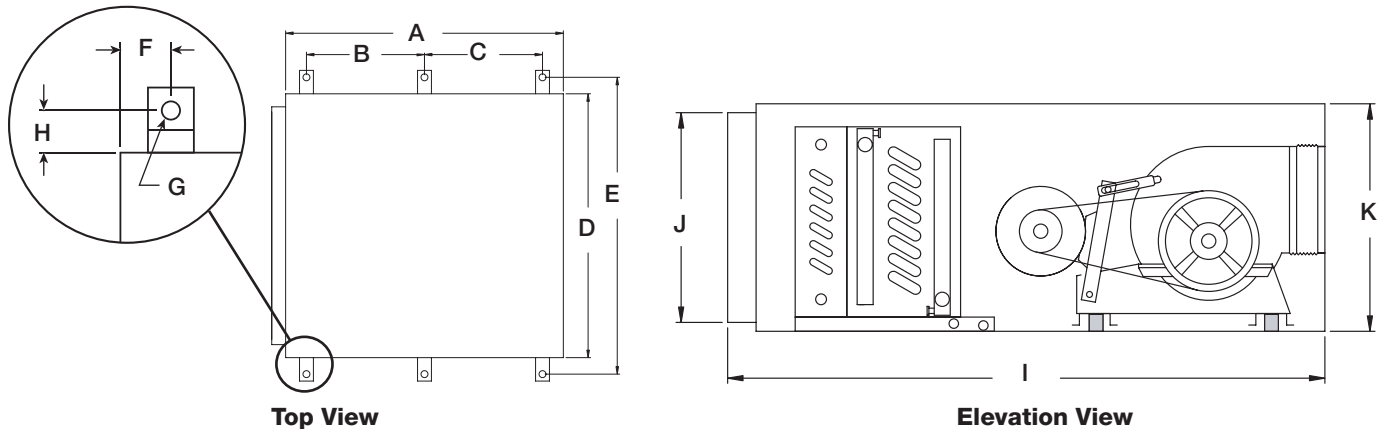

Figure 3

Unit Dimensions



Unit Size	I			J	K	Width	Inlet		Outlet	
	w/o Filter	w/ 2 in. Filter	w/ 4 in. Filter				Height	Width	Height	Width
15	40	42	44	8.0	11.0	38	9.0	36	4.0	6.75
20	40	42	44	11.0	14.0	38	12.0	36	6.5	6.75
25	40	42	44	13.0	16.0	38	14.0	36	8.0	8.5
30	45	47	49	15.5	18.5	38	16.5	36	9.0	9.0
45	45	47	49	14.25	18.5	50	16.5	48	9.0	10.0
50	48	50	52	16.75	21.0	50	19.0	48	10.25	10.0
65	52	54	56	21.75	26.0	50	24.0	48	12.0	12.75
85	52	54	56	21.75	26.0	62	24.0	60	12.0	15.0

All dimensions are in inches.

Weights

Unit Size	Fan w/ Drain Pan			1 Row	2 Row	4 Row	6 Row	8 Row	2 in. Vertical Filter	4 in. Vertical Filter
	Fan	Motor	Total							
15	128	50	178	25	31	44	60	75	5	8
20	151	50	201	32	41	61	83	105	6	10
25	175	60	235	38	51	77	106	135	8	13
30	199	60	259	45	61	94	129	165	9	15
45	250	75	325	51	70	110	152	195	11	17
50	316	75	391	58	80	127	175	225	12	19
65	405	75	480	64	90	143	198	255	14	22
85	450	100	550	71	100	160	221	285	15	24

All weights are shown in pounds (lbs.) Motor weights may vary depending on enclosure type and horsepower.

Mounting Dimensions

Unit Size	Horizontal Hanging							
	A	B	C	D	E	F	G	H
15	40	18.25	19.75	38	43	1	0.5	2.5
20	40	19	19	38	43	1	0.5	2.5
25	40	19	19	38	43	1	0.5	2.5
30	45	19	24	38	43	1	0.5	2.5
45	45	19	24	50	55	1	0.5	2.5
50	48	19	27	50	55	1	0.5	2.5
65	52	19	31	50	55	1	0.5	2.5
85	52	19	31	62	67	1	0.5	2.5

All dimensions are in inches.

Filter Sizes and Quantity

Size	Filter Size	Qty	Face Area (ft ²)
15	9 x 18	2	1.8
20	12 x 12	1	2.5
	12 x 24		
25	14 x 18	2	3.0
30	16 x 16	1	3.4
	16 x 20		
45	16 x 24	2	4.8
50	18 x 24	2	5.4
65	24 x 24	2	7.2
85	12 x 24	1	8.9
	24 x 24	2	

All dimensions are in inches.

Coil Dimensions

Hot Water • 1 and 2 Row

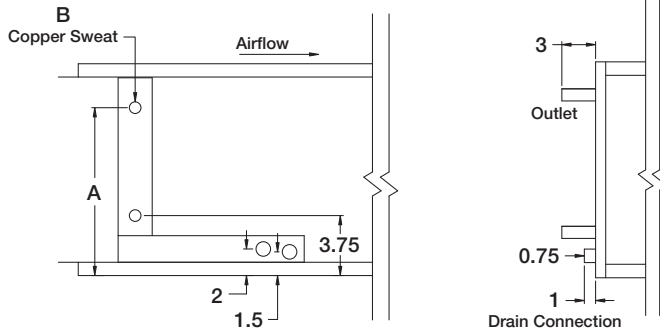

0.25 vent and drain supplied. Right side connection shown.

Unit Size	A	B
15	7.63	0.75
20	10.13	0.75
25	12.63	0.875
30	15.13	0.875
45	15.13	0.875
50	17.63	1.125
65	22.63	1.375
85	22.63	1.375

All dimensions are in inches.

NOTE

Fluid enters the coil from the bottom connection (Inlet) and exits from the top (Outlet).

Hot Water • 4 Row

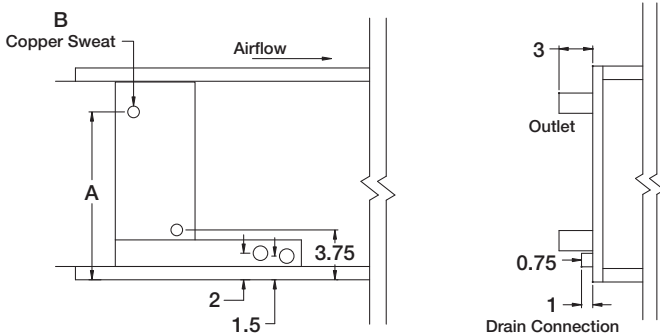

0.25 vent and drain supplied. Right side connection shown.

Unit Size	A	B
15	7.63	0.75
20	10.13	0.75
25	12.63	0.875
30	15.13	0.875
45	15.13	0.875
50	17.63	1.375
65	22.63	1.375
85	22.63	1.375

All dimensions are in inches.

NOTE

With airflow from left to right, the fluid enters the coil from the bottom connection (Inlet) and exits from the top (Outlet). The other two coil connections should be capped off (Cap).

Steam • 1 and 2 Row

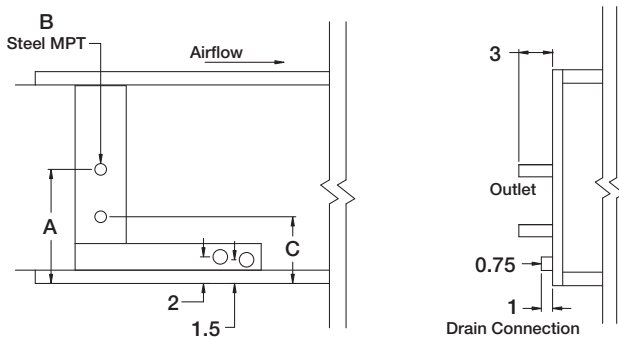

Right side connection shown.

Unit Size	A	B	C
15	7.0	1.5	3.81
20	6.94	1.5	3.56
25	8.19	2.5	3.81
30	9.44	2.5	3.56
45	9.44	2.5	3.56
50	10.69	2.5	4.81
65	13.19	2.5	3.56
85	13.19	2.5	3.56

All dimensions are in inches.

NOTE

Steam enters the coil from the center connection (Inlet) and exits from the bottom (Outlet).

Chilled Water • 4, 6 or 8 Row

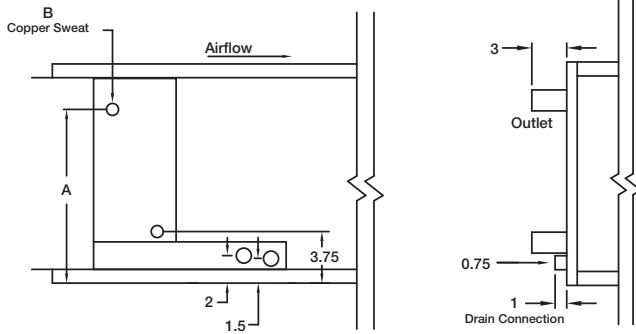

0.25 vent and drain supplied. Right side connection shown.

Unit Size	A	4 row	6 row	8 row
		B	B	B
15	7.63	0.75	0.75	1.375
20	10.13	0.75	0.75	1.375
25	12.63	0.875	0.875	1.375
30	15.13	0.875	0.875	1.375
45	15.13	0.875	0.875	1.375
50	17.63	1.375	1.375	1.625
65	22.63	1.375	1.375	1.625
85	22.63	1.375	1.375	1.625

All dimensions are in inches.

NOTE

With airflow from left to right, the fluid enters the coil from the bottom connection (Inlet) and exits from the top (Outlet). The other two coil connections should be capped off (Cap)

Direct Expansion (DX) • Single Circuit • 4, 6 or 8 Row

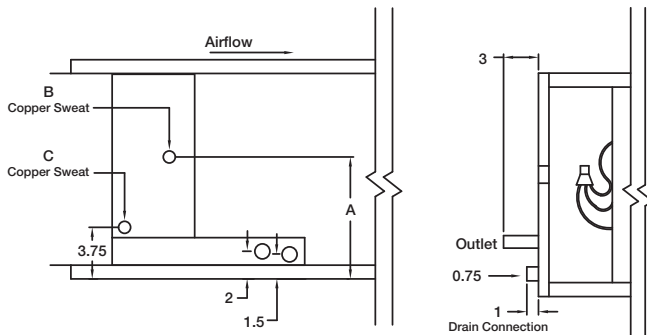

Distributor hookup is done inside module through 2-inch access hole. Right side connection shown.

Unit Size	A	4 row		6 row		8 row	
		B	C	B	C	B	C
15	5.75	0.625	0.625	0.625	0.625	0.625	1.375
20	7.0	0.625	0.625	0.625	0.625	0.625	1.375
25	8.0	0.875	1.375	0.875	1.375	0.875	1.375
30	9.5	0.875	1.375	0.875	1.375	0.875	1.375
45	9.5	0.875	1.375	0.875	1.375	0.875	1.375
50	10.75	0.875	1.375	1.125	1.375	0.875	1.625
65	13.00	1.125	1.375	1.125	1.375	1.125	1.625
85	13.00	1.125	1.375	1.125	1.375	1.125	1.625

All dimensions are in inches.

NOTE

With airflow from left to right, the fluid enters the coil from the center connection (Inlet) and exits from the bottom (Outlet). The other coil connections should be capped off (Cap).

Direct Expansion (DXI) • Dual Circuit with 50/50 Face Interlaced Construction • 4, 6 or 8 Row

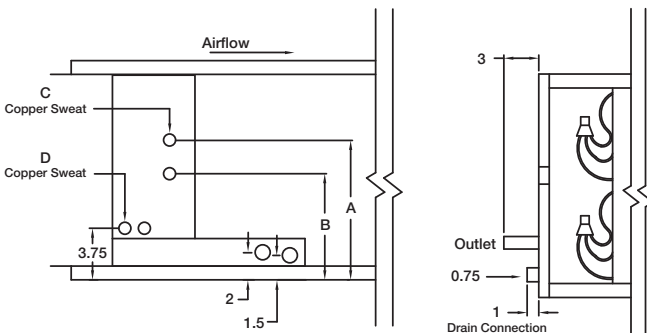

Distributor hookup is done inside module through 2-inch access hole. Right side connection shown.

Unit Size	A	B	4 row		6 row		8 row	
			C	D	C	D	C	D
30	12.00	7.00	0.625	0.625	0.625	0.875	0.625	0.875
45	12.00	7.00	0.625	0.625	0.625	0.875	0.625	0.875
50	13.50	7.75	0.625	0.625	0.625	0.875	0.625	1.125
65	17.00	9.50	0.875	0.875	0.875	1.125	0.875	1.125
85	17.00	9.50	0.875	0.875	0.875	1.125	0.875	1.125

All dimensions are in inches.

NOTE

The first suction header on the entering air side of the coil is circuited to the top distributor. With airflow from left to right, the fluid enters the coil from the center connection (Inlet) and exits from the bottom (Outlet). The other coil connections should be capped off (Cap).

System Start-Up

For proper unit function and safety, follow everything in this start-up procedure in the order presented. This is to be done after the electrical connections are complete.

PRE-START CHECK LIST

1. Disconnect and lock-out all power switches to fan.
2. Check all fasteners, set screws and locking collars on the fan, bearings, drive, motor base and accessories for tightness.
3. Rotate the fan wheel by hand and assure no parts are rubbing.
4. Check the V-belt drive for proper alignment and tension.

SPECIAL TOOLS REQUIRED

- Voltage Meter
- Tachometer
- Amperage Meter

1. Check Voltage

Before starting the unit, compare the supplied voltage with the unit's nameplate voltage and the motor voltage. Units are not provided with thermal overload protection unless a control center has been ordered with the unit or the motor has been selected with thermal overload protection.

2. Check Blower Rotation

If the blower is rotating in the wrong direction, the unit will move some air, but will not perform properly. To check the rotation, open the blower access door and run the blower momentarily to determine the rotation.

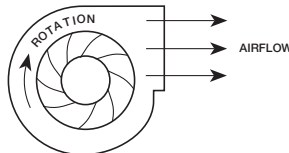

To reverse the rotation, turn the power off and use the following procedure:

- For single phase units, rewire the motor per the instructions on the motor.
- For three phase units, interchange any two power leads. This can be done at the motor starter.

3. Check for Vibration

Check for unusual noise, vibration or overheating of bearings. Excessive vibration maybe experienced during initial start-up. Left unchecked, excessive vibration can cause a multitude of problems, including structural and/or component failure. Many conditions can be discovered by careful observation. If the problem is wheel unbalance, in-place balancing can be done providing there is access to the fan wheel. Generally, fan vibration and noise is transmitted to other parts of the building by the ductwork. If noise is an issue, we recommend using heavy canvas connections on the inlet of the fan. Refer to the Troubleshooting section of this manual if a problem develops.

4. Air Volume Check and Measurement

Along with the building balance, the unit's air volume (cfm) should be measured and compared with its rated air volume. This unit is flexible for varying air volume, but the actual air volume should be known for making final adjustments. The most accurate way to measure the air volume is by using the pitot traverse method in the ductwork away from the blower. Other methods can be used, but should be proven and accurate. To adjust the air volume, change the fan rpm or the system losses. See Troubleshooting section in this guide.

5. Measure Motor Voltage, Amperage and Fan RPM

All access doors must be installed. Measure and record the input voltage and motor amperage(s).

To measure the fan RPM, the blower door will need to be removed. Minimize measurement time because the motor may over amp with the door removed.

Compare measured amps to the motor nameplate full load amps and correct if over amping. See the Troubleshooting section in this guide.

Troubleshooting

Symptom	Possible Cause	Corrective Action
Blower fails to operate	Blown fuse or open circuit breaker	Replace fuse or reset circuit breaker and check amps
	Broken fan belt	Replace
	Defective motor or capacitor	Replace
	Motor starter overloaded	Reset starter and check amps
Motor overamps	Airflow too high	Check airflow and adjust drives if needed
	Static pressures are higher or lower than design	If higher, ductwork should be improved If lower, fan RPMs should be lower
	Blower rotation is incorrect	Check rotation and correct
	Motor voltage incorrect	Check motor nameplate and supplied voltage
	Motor horsepower too low	See specifications and catalog for fan curves to determine if horsepower is sufficient
	Shorted windings in motor	Replace motor
Insufficient airflow	Mixing box damper not fully open	Adjust damper linkage or replace damper motor
	System static pressure too high	Improve ductwork to eliminate losses using good duct practices
	Blower speed too low	Check for correct drives and RPMs with catalog data
	Mixing box dampers closed	Open and adjust
	Dirty or clogged filters	Clean or replace
	Leaks in ductwork	Repair
	Elbows, or other obstructions may restrict fan outlet	Correct or improve ductwork
	Belt slippage	Adjust belt tension
Too much airflow	Blower fan speed too high	Check for correct fan RPM
	Filter(s) not in place	Install filters
	Insufficient static pressure (airflow resistance)	Induce static pressure into system ductwork
Excessive noise or vibration	Wheel rubbing on housing	Center wheel
	Loose wheel on shaft	Tighten wheel setscrew
	Loose motor or blower sheave	Tighten sheave setscrew
	Belts too loose	Adjust belt tension after 24 hours of operation
	Belts too tight	Loosen to maintain 3/8 inch deflection per ft. of span between sheaves
	Worn belt	Replace
	Motor base or blower loose	Tighten mountings bolts
	Worn bearings	Replace
	Bearing and drive alignment	Realign
	Motor out of balance	Replace
	Wheel out of balance	Replace or rebalance
	Sheaves eccentric or out-of-balance	Replace or rebalance
Accumulation of material on wheel	Clean wheel and housing	

Start-Up of Coil Module

Hot Water, Chilled Water Coils

1. Piping should be in accordance with accepted industry standards. Pipework should be supported independently of the coils. Water pipes are copper with sweat connections. **USE WET TOWEL TO AVOID BURNING COIL CONNECTION GROMMETS.** When installing coupling, do not apply undue stress to the connection extending through the unit. Use a back-up pipe wrench to avoid breaking the weld between coil connection and header.
2. Connect the water supply to the bottom connection on the air-leaving side and the water return to the top connection on the air-entering side. The extra bottom connection can be used for an auxiliary manual drain connection, and the extra top connection may be used for an automatic air vent or the extra connections can be capped. To ensure proper venting, an external air vent in the piping is recommended. Connecting the supply and/or return in any other manner will result in very poor performance. **CAP UNUSED CONNECTIONS.**
3. The air vent at the uppermost point should be temporarily opened during system start-up to release all of the air from the coil. To maintain heat transfer capacity, periodically vent any air in the coil. Vent is to be located behind the connections side access door.
4. Water coils are not normally recommended for use with entering air temperatures below 40°F. No control system can be depended on to be 100% safe against freeze-up with water coils. Glycol solutions or brines are the only safe media for operation of water coils with low entering air conditions.

WARNING

Continuous water circulation through the coil at all times is highly recommended.

5. Pipe sizes for the system must be selected on the basis of the head (pressure) available from the circulation pump. Piping should be in accordance with accepted industry standards.
6. For chilled water coils, the condensate drain pipe should be sized adequately to ensure the condensate drains properly. See Drain Pan Traps section and related drawing.

Direct Expansion (DX) Coils

1. Piping should be in accordance with accepted industry standards. Pipework should be supported independently of the coils. Undue stress should not be applied at the connection to coil headers.

2. The condensate drain pipe should be sized adequately to ensure the condensate drains properly. See Drain Pan Traps section and related drawing.
3. When connecting suction and liquid connections, make sure the coil is free from all foreign material. Make sure all joints are tight and free of leakage.
4. Dual circuits are recommended to be run by two compressors. One compressor with the appropriate valves and piping can be used but is not recommended. Greenheck does not supply compressor or condensing units, for further instruction on DX coil installation and operation, contact your compressor and/or condenser manufacturer.

DXI coils have dual connections and should be used with two compressors.

WARNING

Standard unit insulation of 1.5 lbs. density has an insulation R-value of 3.7.

For applications where the unit discharge temperatures are below 55°F and the unit is installed in a warm, humid environment, additional insulation may need to be applied to the exterior of the unit to prevent condensation.

Steam Coils Application Recommendations

Satisfactory operation and service life are best ensured when coils are installed with proper piping, trap and support arrangement. The following notes and drawing are recommended for the coil unit installation and operation.

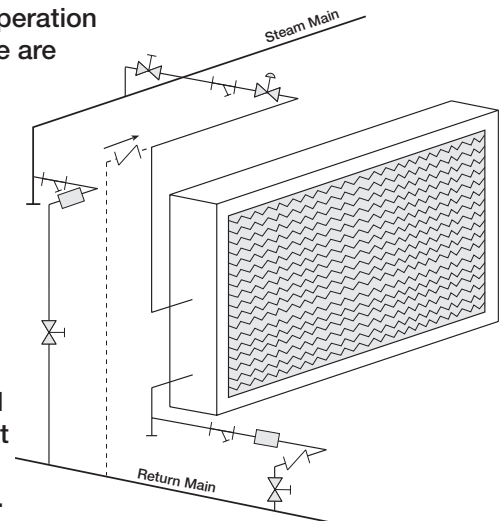

General

1. Provide separate supports and hangers for the unit and the piping.
2. Be certain that adequate piping flexibility is provided. Stresses resulting from expansion of closely coupled piping and coil arrangement can cause serious damage.

Steam Coils, General - *continued*

3. Standard steam coils are pitched in the casings when installed for horizontal airflow. The casing must be level after the unit is installed for proper condensate drainage. If condensate is not removed, the coil will suffer from water hammering and will have a shortened life. On vertical airflow applications, the coils must be pitched when installed.
4. Do not reduce pipe size at the coil return connection. Carry return connection size through the dirt pocket, making the reduction at the branch leading to the trap.
5. It is recommended that vacuum breakers be installed on all applications to prevent retaining condensate in the coil. Generally, the vacuum breaker is to be connected between the coil inlet and the return main. The vacuum breaker should be open to the atmosphere and the trap design should allow venting of large quantities of air.
6. Do not attempt to lift condensate when using modulating or on-off control.
7. Do not reduce the pipe size leaving the coil.

Traps

1. Size traps in accordance with the manufacturer's recommendations. Be certain that the required pressure differential will always be available. **DO NOT UNDERSIZE.**
2. Float and thermostatic or bucket traps are recommended for low pressure steam. On high pressure systems, bucket traps are normally recommended. The thermostatic traps should be used only for air venting.
3. Bucket traps are recommended for use with on-off control only.
4. Locate traps at least 12 inches below the coil return connection.

Controls

1. On high pressure installations, a two-position steam valve with a face and bypass arrangement is preferred where modulating control is required.
2. Modulating valves must be sized properly. **DO NOT UNDERSIZE.**

Freezing Conditions (entering air below 35°F)

1. 5 PSI steam must be supplied to the coil at all times.
2. Modulating valves are not recommended. Control should be by means of face and bypass dampers.
3. Provision should always be made to thoroughly mix fresh air and return air before it enters the coil on return air units. Also, temperature control elements must be properly located to obtain true air mixture temperatures.
4. As additional protection against freeze-up, the trap should be installed sufficiently—far below the coil to provide an adequate hydrostatic head to ensure removal of condensate during an interruption in the steam pressure. Estimate 3 feet for each 1 PSI of trap differential required.
5. On start-up, admit steam to coil ten minutes before admitting outdoor air.
6. Provision must be made to close fresh air dampers if steam supply pressure falls below minimum specified.

Drain Pan / Drain Trap

Drain lines and traps should be run full size from the drain pan connection. Drain pans should have drain lines and traps to permit the condensate from the coils to drain freely. On all units with drain pans, the trap depth and the distance between the trap outlet and the drain pan outlet should be twice the static pressure (P) in the drain pan section under normal operation to assure the trap remains sealed.

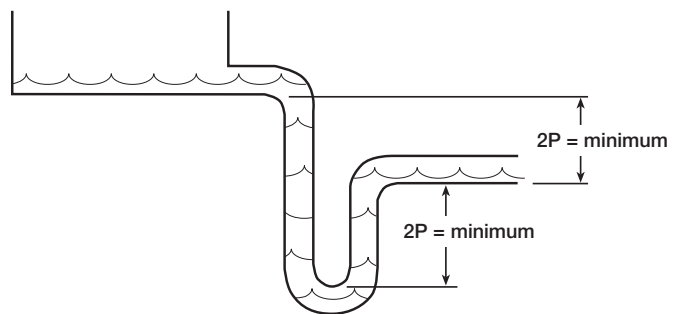

Drain Pan / Drain Trap

Fan Maintenance

Greenheck recommends these procedures to ensure trouble free operation of this unit. It is especially important to maintain heater units for clean and efficient operation. Most unit failures can be attributed to poor setup or poor maintenance.

A record of maintenance performed on this unit should be kept. This information will provide essential information if problems are encountered. A section at the back of this manual is provided for recording the unit's maintenance history.

CAUTION

When performing any maintenance on this unit, be sure that the power is disconnected and cannot be accidentally turned on. The control center disconnect can be locked in the off position.

Two Weeks after Start-Up

Belts - Belts tend to stretch after a period of time. They should be periodically checked for wear and tightness. Approximately 3/8 inch of deflection per ft. of span between sheaves is standard for belt tightness. When replacing belts, use the same type as supplied with the unit. Matched belts should always be used on units with multigroove pulleys.

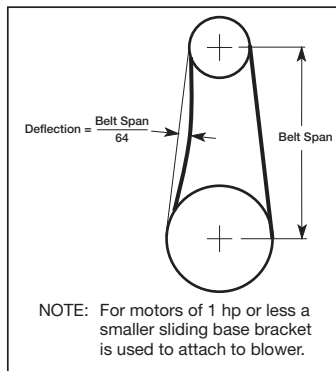

Replacement of belts can be accomplished by loosening the motor to the point where the belts can be removed by hand. Do not force belts on or off as this may cause breakage of cords leading to premature belt failure. Belts should be adjusted as above.

Every Three (3) Months

Filters - The filter in the unit should be inspected at least every three (3) months. Depending on the environment, filters could require changing or cleaning more or less often. The filters can be slid out of either side of the unit.

If washable filters are installed, they can be washed in warm soapy water. An adhesive spray can be applied to increase filter efficiency.

If disposable filters are installed, check by holding up to a light source. If light cannot pass through the filter, it should be replaced. Replacement filters should be of the same manufacturer and size. When reinstalling filters, be sure to install with the airflow in the correct direction indicated on the filter.

Yearly

Bearings — Most bearings are permanently lubricated and require no further lubrication under normal use. Normal use being considered -20°F to 120°F and in a relatively clean environment. Some bearings are relubricatable and will need to be regreased depending on fan use. Check your bearings for grease fittings to find out what type of bearing you have. If your fan is not being operated under normal use, bearings should be checked monthly for lubrication.

Motors — Motor maintenance is generally limited to cleaning and lubrication (where applicable). Cleaning should be limited to the exterior surfaces only. Removing dust and grease buildup on motor housing assures proper motor cooling. Greasing of motors is intended only when grease fittings are provided. Many fractional motors are permanently lubricated and require no further lubrication. Motors supplied with grease fittings should be greased in accordance with manufacturer's recommendations. When motor temperature does not exceed 104°F (40°C), the grease should be replaced after 2000 hours of running time as a general rule.

Wheels — Wheels require very little attention when moving clean air. Occasionally, oil and dust may accumulate on the wheel causing imbalance. When this occurs the wheel and housing should be cleaned to assure smooth and safe operation. Inspect fan impeller and housing for fatigue, corrosion or wear. Routinely check all fasteners, set screws and locking collars on the fan, bearing, drive, motor base and accessories for tightness.

Coil Maintenance

Coils must be clean to obtain maximum performance. Check once a year under normal operating conditions and, if dirty, brush or vacuum clean. Soiled fins reduce the capacity of the coil, demand more energy from the fan, and create an environment for odor and bacteria to grow and spread through the conditioned zone.

High pressure water (400 psi or less) may be used to clean coils with fin thickness over 0.006 inches thick.

Test the spray pressure over a small corner of the coil to determine if the fins will withstand the spray pressure.

For coils with fragile fins or high fin density, foaming chemical sprays and washes are available. Many coil cleaners contain harsh chemicals, so they must be used with caution by qualified personnel only. Care must be taken not to damage the coils, including fins, while cleaning.

CAUTION

Fin edges are sharp.

Winterizing Coils

Coil freeze-up can be caused by such things as air stratification and failure of outdoor air dampers and/or preheat coils. Routine draining of water cooling coils for winter shutdown cannot be depended upon as insurance against freeze-up. Severe coil damage may result. It is recommended that all coils be drained as thoroughly as possible and then treated in the following manner.

Fill each coil independently with an antifreeze solution using a small circulating pump and again thoroughly drain. Check freezing point of antifreeze before proceeding to next coil. Due to a small amount of water always remaining in each coil, there will be diluting effect. The small amount of antifreeze solution remaining in the coil must always be concentrated enough to prevent freeze-up.

NOTE: Carefully read instructions for mixing antifreeze solution used. Some products will have a higher freezing point in their natural state than when mixed with water.

Drain Pan Maintenance

Drain pans in any air conditioning unit will have some moisture in them, therefore, algae and other organisms will grow due to airborne spores and bacteria. Periodic cleaning is necessary to prevent this buildup from plugging the drain and causing the drain pan to overflow. Inspect twice a year to avoid the possibility of overflow. Also, drain pans should be kept clean to prevent the spread of disease. Cleaning should be performed by qualified personnel.

Start-Up Documentation

Job Information

Job Name _____

Address _____

City _____ State _____ Zip _____

Phone Number _____

Contact Person _____

Start-Up Company Information

Service Organization _____

Address _____

City _____ State _____ Zip _____

Phone Number _____

Fax Number _____

Start-Up Date _____

Start-Up Personnel Name _____

Nameplate Information

Unit Model Number _____

Volts _____ Hertz _____ Phase _____

Amps _____ Mark _____

Fan rpm _____

Unit Serial Number _____

Field Start-Up Documentation

Check blower rotation

Check air volume (cfm)

_____ Design

_____ Actual

Actual motor voltage _____ Volts

Actual motor hertz _____ Hertz

Actual motor phase _____ Phase

Actual motor amps _____ Amps

Drive

Fan RPM Range

_____ Minimum

_____ Maximum

Maintenance Log

Date _____ Time _____ AM/PM

Notes: _____

Date _____ Time _____ AM/PM

Notes: _____

Date _____ Time _____ AM/PM

Notes: _____

Date _____ Time _____ AM/PM

Notes: _____

Date _____ Time _____ AM/PM

Notes: _____

Date _____ Time _____ AM/PM

Notes: _____

Date _____ Time _____ AM/PM

Notes: _____

Date _____ Time _____ AM/PM

Notes: _____

Date _____ Time _____ AM/PM

Notes: _____

Date _____ Time _____ AM/PM

Notes: _____

Date _____ Time _____ AM/PM

Notes: _____

Date _____ Time _____ AM/PM

Notes: _____



Maintenance Log

Date _____ Time _____ AM/PM

Notes: _____

Date _____ Time _____ AM/PM

Notes: _____

Date _____ Time _____ AM/PM

Notes: _____

Date _____ Time _____ AM/PM

Notes: _____

Date _____ Time _____ AM/PM

Notes: _____

Date _____ Time _____ AM/PM

Notes: _____

Date _____ Time _____ AM/PM

Notes: _____

Date _____ Time _____ AM/PM

Notes: _____

Date _____ Time _____ AM/PM

Notes: _____

Date _____ Time _____ AM/PM

Notes: _____

Date _____ Time _____ AM/PM

Notes: _____

Date _____ Time _____ AM/PM

Notes: _____



Maintenance Log

Date _____ Time _____ AM/PM

Notes: _____

Date _____ Time _____ AM/PM

Notes: _____

Date _____ Time _____ AM/PM

Notes: _____

Date _____ Time _____ AM/PM

Notes: _____

Date _____ Time _____ AM/PM

Notes: _____

Date _____ Time _____ AM/PM

Notes: _____

Date _____ Time _____ AM/PM

Notes: _____

Date _____ Time _____ AM/PM

Notes: _____

Date _____ Time _____ AM/PM

Notes: _____

Date _____ Time _____ AM/PM

Notes: _____

Date _____ Time _____ AM/PM

Notes: _____

Date _____ Time _____ AM/PM

Notes: _____



Warranty

Greenheck warrants this equipment to be free from defects in material and workmanship for a period of one year from the shipment date. Any units or parts which prove defective during the warranty period will be replaced at our option when returned to our factory, transportation prepaid. Motors are warranted by the motor manufacturer for a period of one year. Should motors furnished by Greenheck prove defective during this period, they should be returned to the nearest authorized motor service station. Greenheck will not be responsible for any removal or installation costs.

As a result of our commitment to continuous improvement, Greenheck reserves the right to change specifications without notice.

Greenheck Catalog IAH Series (MSCF-FC • MSCF-BI • LFC-C • VFC-FC • VFCD-FC) provides additional information describing the equipment, fan performance, available accessories, and specification data.

AMCA Publication 410-96, Safety Practices for Users and Installers of Industrial and Commercial Fans, provides additional safety information. This publication can be obtained from AMCA International, Inc. at www.amca.org.



Phone: (715) 359-6171 • Fax: (715) 355-2399 • E-mail: gfcinfo@greenheck.com • Web site: www.greenheck.com

Free Manuals Download Website

<http://myh66.com>

<http://usermanuals.us>

<http://www.somanuals.com>

<http://www.4manuals.cc>

<http://www.manual-lib.com>

<http://www.404manual.com>

<http://www.luxmanual.com>

<http://aubethermostatmanual.com>

Golf course search by state

<http://golfingnear.com>

Email search by domain

<http://emailbydomain.com>

Auto manuals search

<http://auto.somanuals.com>

TV manuals search

<http://tv.somanuals.com>