

APPLICATION

Model FSD-311V is a vertical blade class I leakage rated combination fire smoke damper. High strength airfoil blades ensure the lowest resistance to airflow in HVAC systems with velocities to 4000 fpm (20.3m/s) and 4 in. wg (1.0 kPa).

RATINGS

UL 555 Fire Resistance Rating:

Fire Rating: 1½ hours
Dynamic Closure Rating: Actual ratings are size dependent
Max. Velocity: up to 4000 fpm (20.3 m/s)
Max. Pressure: 4 in. wg (1 kPa)

UL555S Leakage Rating:

Leakage Class: I
Operational Rating: Actual ratings are size dependent
Max. Velocity: up to 4000 fpm (20.3m/s)
Max. Pressure: 4 in. wg (1 kPa)
Maximum Temperature: 350°F (177°C)- depending upon the actuator

STANDARD CONSTRUCTION

Frame: 5 in. x 1 in. (127mm x 25mm) galvanized steel hat channel with reinforced corners. A low profile head and sill are used on sizes less than 17 in. (432mm) high to maximize free area and performance.

Blades: Double skin airfoil shape of galvanized steel with full length structural reinforcement. 14 ga. (2 mm) equivalent thickness.

Seals: Extruded silicone rubber blade seals. Flexible stainless steel jamb seals.

Closure Device: RRL 165°F (74°C)

Linkage: Concealed in jamb.

Axles: 1/2 in. (13mm) dia. plated steel.

Bearings: 304 stainless steel

SIZE LIMITATIONS:

Minimum Size: 6 in. W x 8 in. H
 (152mm W x 203mm H)

**Maximum Size-
 Single Section:** 50 in. W x 32 in. H
 (1270mm W x 813mm H)

Multiple Section: 100 in. W x 32 in. H
 (2540mm W x 813mm H)

OPTIONAL FEATURES

- OCI (Open closed indication switches)
- Electric or pneumatic actuators to accomplish smoke management and system functions.
- Transitions (R, C, O)
- POC retaining angles
- Momentary Switch
- Sealed transitions and sleeves
- RRL/OCI (Open closed indication switches)
- 165°F (74°C), 212°F (100°C), 250°F (121°C), 350°F (177°C) RRL's available
- TOR (remote override closure allows damper to perform smoke management functions during a fire emergency.)
- PRV (pneumatic relief valve)
- Security Bars
- Sealed transitions and sleeves

Model FSD-311V meets the requirements for fire dampers, smoke dampers and combination fire smoke dampers established by:

National Fire Protection Association

NFPA Standards 80, 90A, 92A, 92B, 101 & 105

IBC International Building Codes

ICBO Uniform Building Codes

CSFM California State Fire Marshal

Fire Damper Listing (#3225-0981:103)

Leakage (Smoke) Damper Listing (#3230-0981:104)

New York City (MEA listing #260-91-M)

"UL CLASSIFIED (see complete marking on product)"

"UL CLASSIFIED to Canadian safety standards (see complete marking on product)"
 Standard 555 & 555S (Listing #R13317)

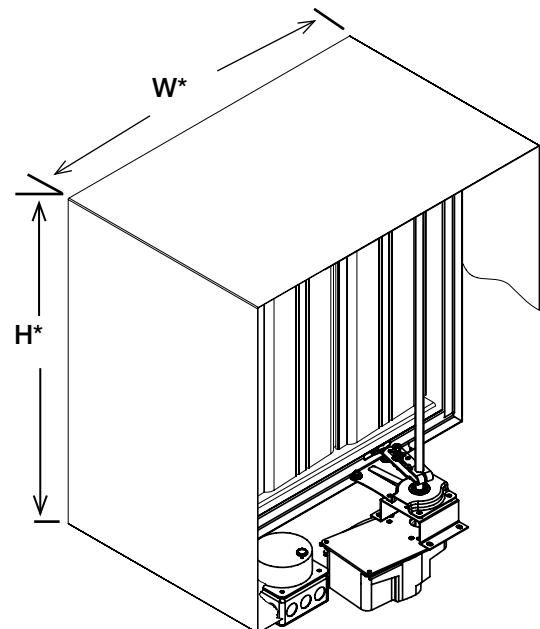

*W&H dimensions furnished approximately 1/4 in. (6mm) undersize.

Installation instructions available at www.greenheck.com

This pressure drop testing was conducted in accordance with AMCA Standard 500-D₃ using the three configurations shown. All data has been corrected to represent standard air at a density of .075 lb/ft³ (1.2 kg/m³).

Actual pressure drop found in any HVAC system is a combination of many factors. This pressure drop information along with an analysis of other system influences should be used to estimate actual pressure losses for a damper installed in a given HVAC system.

AMCA Test Figures

Figure 5.3 Illustrates a fully ducted damper. This configuration has the lowest pressure drop of the three test configurations because entrance and exit losses are minimized by straight duct runs upstream and downstream of the damper.

Figure 5.2 Illustrates a ducted damper exhausting air into an open area. This configuration has a lower pressure drop than Figure 5.5 because entrance losses are minimized by a straight duct run upstream of the damper.

Figure 5.5 Illustrates a plenum mounted damper. This configuration has the highest pressure drop because of extremely high entrance and exit losses due to the sudden changes of area in the system.

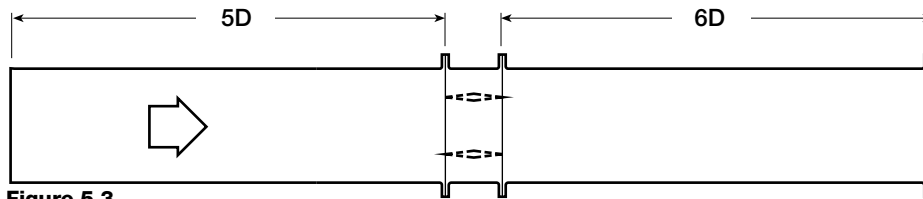

Figure 5.3

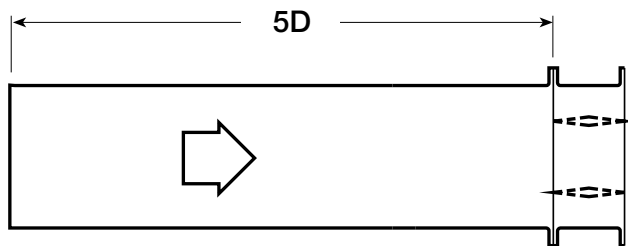

Figure 5.2

$$D = \sqrt{\frac{4(W)(H)}{3.14}}$$

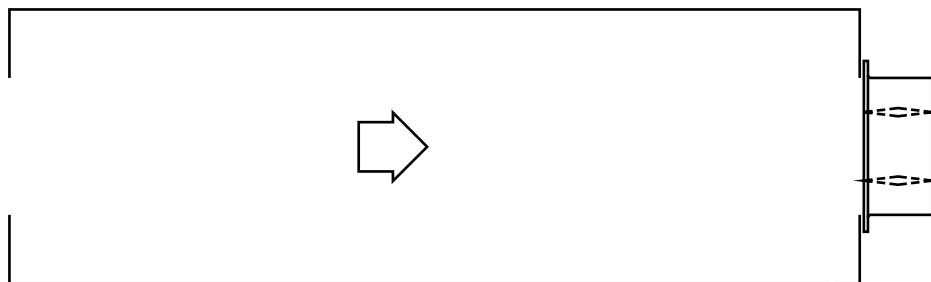
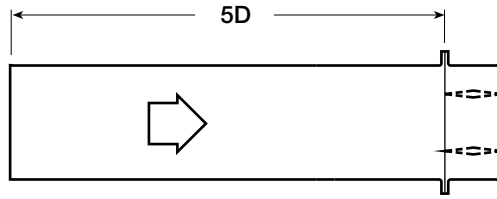
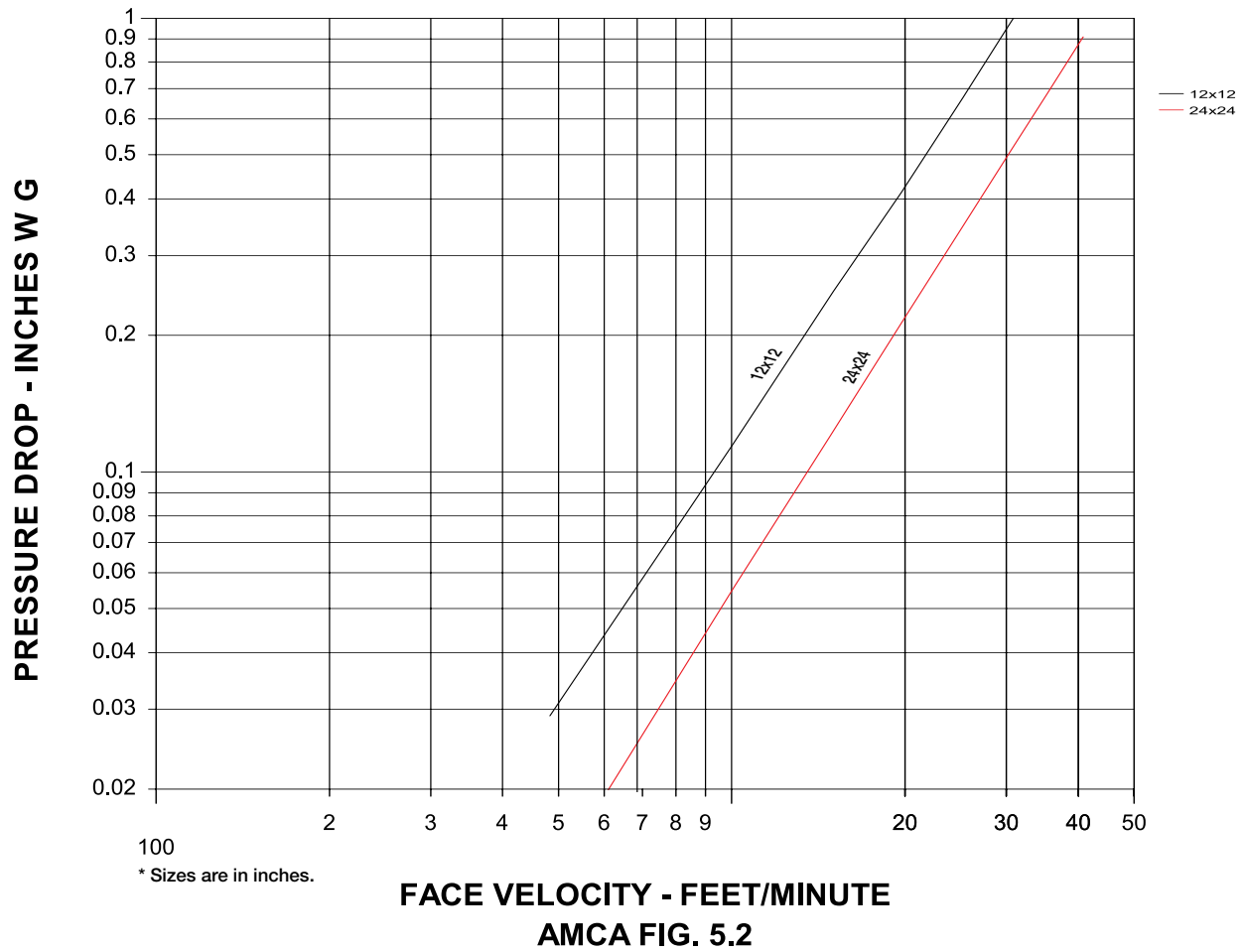

Figure 5.5



VELOCITY VS. PRESSURE DROP



12 in. x 12 in. (305mm x 305mm)

Velocity (fpm)	Pressure Drop (in. wg)
500	0.03
1000	0.12
1500	0.26
2000	0.46
2500	0.72
3000	1.04
3500	1.41
4000	1.84

24 in. x 24 in. (610mm x 610mm)

Velocity (fpm)	Pressure Drop (in. wg)
500	0.01
1000	0.06
1500	0.12
2000	0.22
2500	0.34
3000	0.49
3500	0.67
4000	0.87

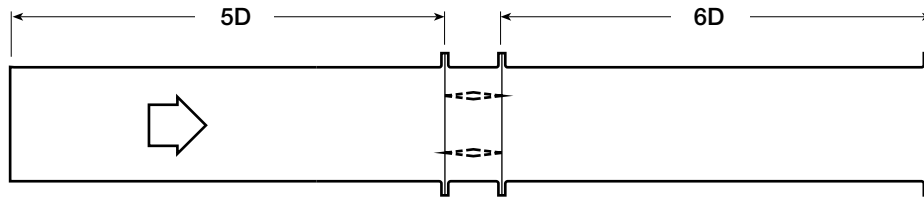

VELOCITY VS. PRESSURE DROP

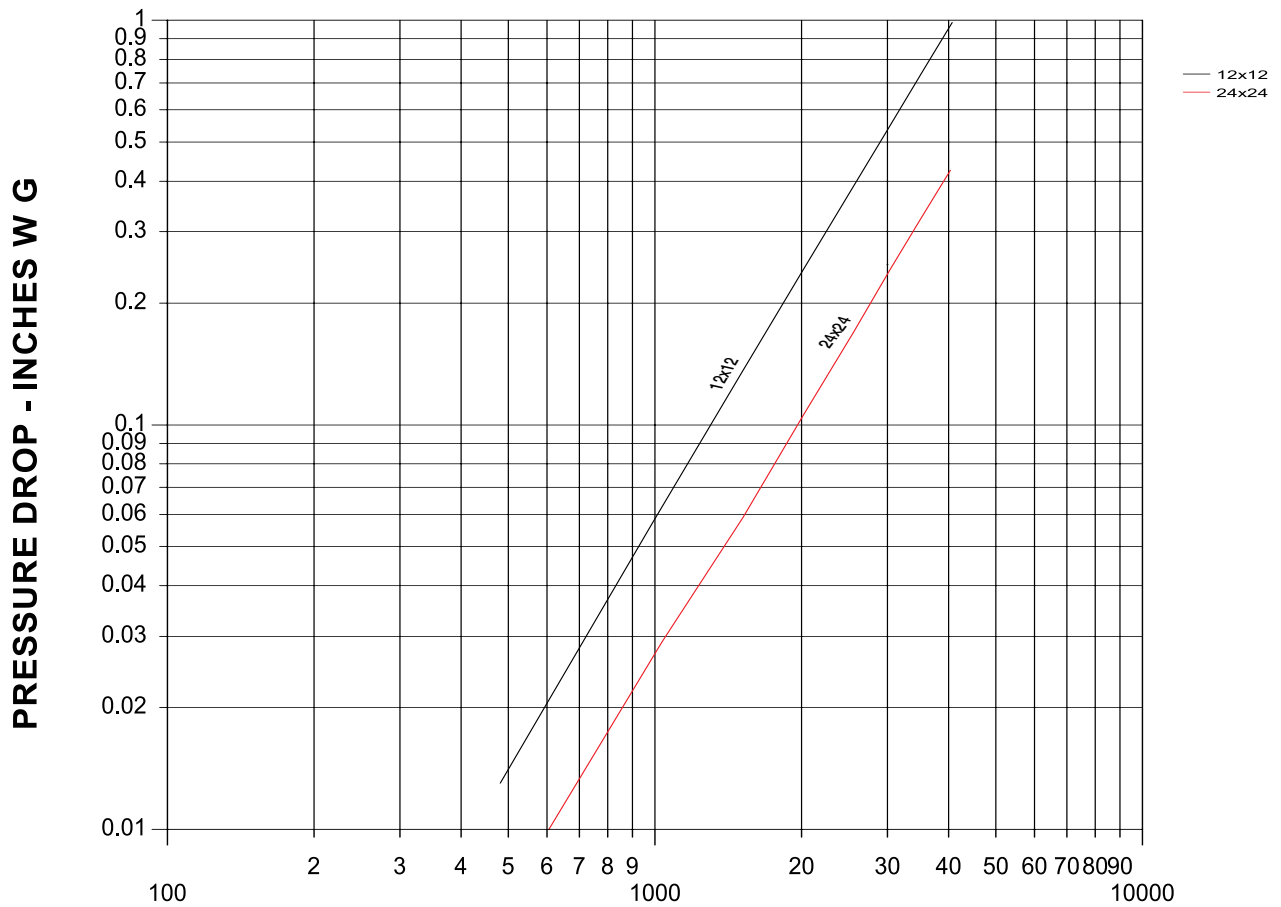

* Sizes are in inches.

FACE VELOCITY - FEET/MINUTE

AMCA FIG. 5.3

12 in. x 12 in. (305mm x 305mm)

Velocity (fpm)	Pressure Drop (in. wg)
500	0.01
1000	0.06
1500	0.13
2000	0.23
2500	0.37
3000	0.53
3500	0.73
4000	0.95

24 in. x 24 in. (610mm x 610mm)

Velocity (fpm)	Pressure Drop (in. wg)
500	0.01
1000	0.02
1500	0.06
2000	0.10
2500	0.16
3000	0.23
3500	0.32
4000	0.42

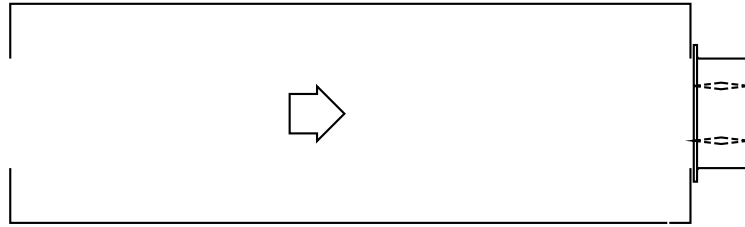

VELOCITY VS. PRESSURE DROP

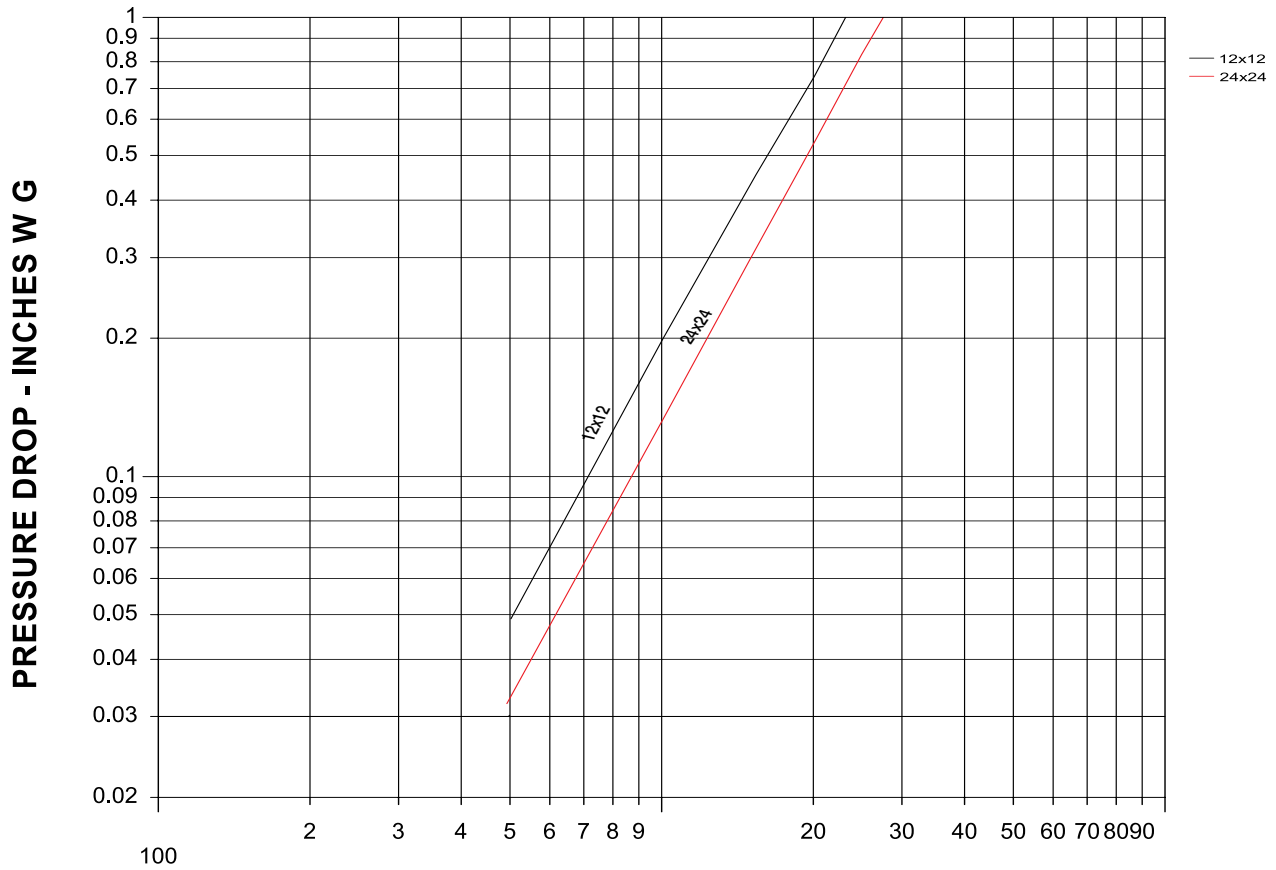

* Sizes are in inches.

FACE VELOCITY - FEET/MINUTE
AMCA FIG. 5.5

12 in. x 12 in. (305mm x 305mm)

Velocity (fpm)	Pressure Drop (in. wg)
500	0.04
1000	0.18
1500	0.42
2000	0.75
2500	1.17
3000	1.68
3500	2.29
4000	2.09

24 in. x 24 in. (610mm x 610mm)

Velocity (fpm)	Pressure Drop (in. wg)
500	0.03
1000	0.13
1500	0.29
2000	0.52
2500	0.81
3000	1.17
3500	1.60
4000	2.14

Transitioned Damper Dimensions

When a combination fire smoke damper is being used in conjunction with round or oval ductwork, the FSD-311V can be supplied in a factory sleeve with round or oval transitions on both ends of the sleeve. Dampers should be ordered to the duct dimensions. Drawings below show overall damper size.

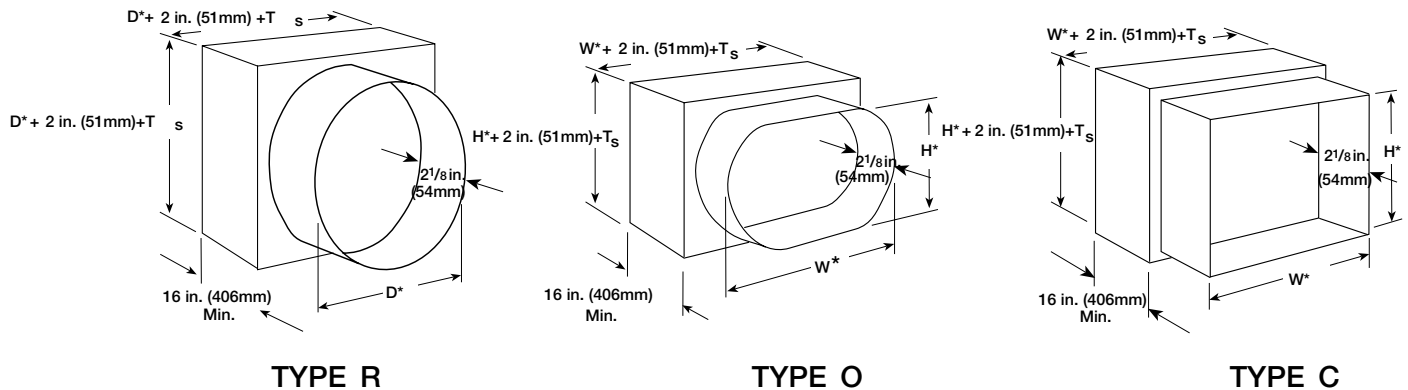

* These dimensions are furnished approximately 1/4 in. (6mm) undersize, except round and oval dimensions which are approximately 1/8 in. (3mm) undersize.
 $T_s = 2(\text{Sleeve Thickness})$

Specifications

Combination Fire Smoke Dampers meeting the following specifications shall be furnished and installed where shown on plans and/or as described in schedules. Dampers shall meet the requirements of NFPA 80, 90A, 92A, 92B, 101 & 105 and further shall be tested, rated and labeled in accordance with the latest edition of UL Standards 555 and 555S. Dampers shall have a UL555 fire rating of 1 1/2 hours and be of low leakage design qualified to UL 555S Leakage Class I.

Each damper/actuator combination shall have a UL555S elevated temperature rating of 250°F (121° C) minimum and shall be rated to operate at maximum design air flow at its installed location. Each damper shall be supplied with an appropriate actuator installed by the damper manufacturer at the time of damper fabrication. Damper actuator shall be (specifier select one of the following) electric type for 120 (or 24) Volt operation or pneumatic type for 25 psi minimum (30 psi maximum) operation.

Damper blades shall be of the double skin airfoil type and shall have an equivalent metal thickness of 14 ga. (2mm). Damper frame shall be galvanized steel formed into a structural hat channel shape with

reinforced corners. Bearings shall be 304 stainless steel rotating in extruded holes in the damper frame. Blade edge seals shall be silicone rubber designed to inflate and provide a tighter seal against leakage as pressure on either side of the damper increases. Jamb seals shall be stainless steel compression type. Blades shall be completely symmetrical relative to their axle pivot point, presenting identical resistance to airflow in either direction or pressure on either side of the damper.

Damper must be rated for mounting vertically (with blades running vertical) and be UL 555S rated for leakage and airflow in either direction through the damper. Each damper shall be supplied with 165°F (74°C) RRL.

The Damper manufacturer's submittal data shall certify all air performance pressure drop data is tested in accordance with the AMCA Certified Ratings Program for Test Figures 5.2, 5.3, and 5.5. Damper air performance data shall be developed in accordance with the latest edition of AMCA Standard 500-D.

The basis of design is Greenheck Model FSD-311V.



P.O. Box 410 • Schofield, WI 54476-0410 • 715.359.6171 • greenheck.com

Copyright ©2007 Greenheck Fan Corporation
 FSD-311V Rev. 3 June 2007

Free Manuals Download Website

<http://myh66.com>

<http://usermanuals.us>

<http://www.somanuals.com>

<http://www.4manuals.cc>

<http://www.manual-lib.com>

<http://www.404manual.com>

<http://www.luxmanual.com>

<http://aubethermostatmanual.com>

Golf course search by state

<http://golfingnear.com>

Email search by domain

<http://emailbydomain.com>

Auto manuals search

<http://auto.somanuals.com>

TV manuals search

<http://tv.somanuals.com>