

## WARRANTY INFORMATION

Qua Tech Inc. warrants the **DS-2000** to be free of defects for **one (1) year** from the date of purchase. Qua Tech Inc. will repair or replace any board that fails to perform under normal operating conditions and in accordance with the procedures outlined in this document during the warranty period. Any damage that results from improper installation, operation, or general misuse voids all warranty rights.

Although every attempt has been made to guarantee the accuracy of this manual, Qua Tech Inc. assumes no liability for damages resulting from errors in this document. Qua Tech Inc. reserves the right to edit or append to this document at any time without notice.

Please complete the following information and retain for your records. Have this information available when requesting warranty service.

DATE OF PURCHASE:

MODEL NUMBER: **DS-2000**

PRODUCT DESCRIPTION: **DUAL CHANNEL RS-422 ASYNC.**  
**COMMUNICATIONS ADAPTER**

SERIAL NUMBER:

IBM PC/XT/AT™, PS/2™, and MicroChannel™ are trademarks of International Business Machines.

## TABLE OF CONTENTS

WARRANTY INFORMATION . . . . .	i
LIST OF FIGURES . . . . .	iii
I. INTRODUCTION . . . . .	1
II. BOARD DESCRIPTION . . . . .	1
III. 16550 FUNCTIONAL DESCRIPTION . . . . .	3
A. INTERRUPT ENABLE REGISTER . . . . .	4
B. INTERRUPT IDENTIFICATION REGISTER . . . . .	5
C. FIFO CONTROL REGISTER . . . . .	7
D. LINE CONTROL REGISTER . . . . .	8
E. MODEM CONTROL REGISTER . . . . .	10
F. LINE STATUS REGISTER . . . . .	11
G. MODEM STATUS REGISTER . . . . .	13
H. SCRATCHPAD REGISTER . . . . .	14
IV. FIFO INTERRUPT MODE OPERATION . . . . .	14
V. BAUD RATE SELECTIONS . . . . .	14
VI. ADDRESSING . . . . .	16
VII. INTERRUPTS . . . . .	16
VIII. PROGRAMMABLE OPTION SELECT . . . . .	16
IX. OUTPUT CONFIGURATIONS . . . . .	19
X. EXTERNAL CONNECTIONS . . . . .	23
XI. INSTALLATION . . . . .	24
XII. SPECIFICATIONS . . . . .	24

## LIST OF FIGURES

Figure 1.	DS-2000 board layout . . . . .	2
Figure 2.	16550 internal registers . . . . .	3
Figure 3.	Interrupt enable register . . . . .	4
Figure 4.	Interrupt identification register . . . . .	5
Figure 5.	Interrupt source identification . . . . .	6
Figure 6.	FIFO control register . . . . .	7
Figure 7.	FIFO receiver trigger levels . . . . .	7
Figure 8.	Line control register . . . . .	8
Figure 9.	Parity options . . . . .	9
Figure 10.	Word length and stop bit options . . . . .	9
Figure 11.	MODEM control register . . . . .	10
Figure 12.	Line status register . . . . .	11
Figure 13.	MODEM status register . . . . .	13
Figure 14.	Input clock frequency options . . . . .	15
Figure 15.	Divisor latch options . . . . .	15
Figure 16.	POS implementation . . . . .	17
Figure 17.	Base address locations . . . . .	18
Figure 18.	Interrupt request levels . . . . .	18
Figure 19.	Output control block diagram . . . . .	21
Figure 20.	J2/J3 layout and settings . . . . .	21
Figure 21.	Auxiliary channel configuration (handshake mode) . . . . .	22
Figure 22.	Auxiliary channel configuration (external clock mode) . . . . .	22
Figure 23.	Auxiliary channel configuration (loopback mode) . . . . .	22
Figure 24.	Output connections . . . . .	23
Figure 25.	Output signal definitions . . . . .	23

## **I. INTRODUCTION**

The DS-2000 is a dual channel asynchronous serial communication adapter which utilizes balanced differential drivers and receivers to provide RS-422-A communications. It is capable of reliable communications over long distances (4000 feet) within noisy industrial environment. Data is communicated through two D-9 connectors which provide shielding from environmental noise. Optional high speed transient suppressers may also be installed on the DS-2000 to further reduce the effects of environmental signal transients and surges.

The serial interface is accomplished through a pair of 16550 Asynchronous Communication Elements (ACEs). The 16550 is compatible with the 8250 and 16450 ACEs used in the IBM PC/XT/AT models. The 16550 also has an additional FIFO mode that reduces CPU overhead at higher data rates.

The DS-2000 supports sixteen base addresses for each ACE through the Programmable Option Select (POS) including the eight addresses designated SERIAL 1 through SERIAL 8. The addresses are independent for each channel. CPU interrupt level selections are also handled through the POS. Each channel may select a separate interrupt or share an interrupt level with other devices.

## **II. BOARD DESCRIPTION**

A component diagram of the DS-2000 showing the locations of the 16550 ACEs, configuration jumpers, and D-9 connectors is shown in figure 1. The first communication channel is controlled by the 16550 labeled U9, jumper J2, and is accessed through the connector labeled CN1. The second channel uses the 16550 labeled U10, jumper J3, and is accessed through the connector labeled CN2. The clock rate divider for both channels is controlled by jumper J1.

FUNCTIONAL DESCRIPTION

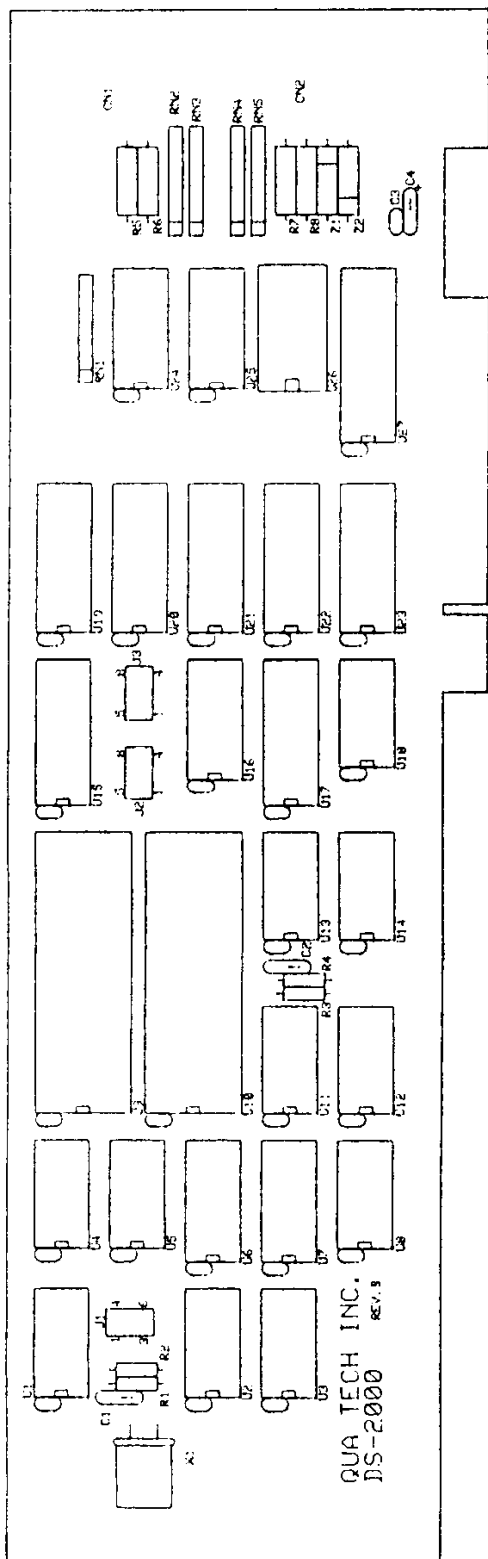

Figure 1. DS-2000 board layout.

## FUNCTIONAL DESCRIPTION

### III. 16550 FUNCTIONAL DESCRIPTION

The 16550 is an upgrade of the standard 16450 Asynchronous Communications Element (ACE). Designed to be compatible with the 16450, the 16550 enters the character mode on reset and in this mode will appear as a 16450 to user software. An additional mode, FIFO mode, can be selected to reduce CPU overhead at high data rates. The FIFO mode increases performance by providing two internal 16-byte FIFOs (one transmit and one receive) to buffer data and reduce the number of interrupts issued to the CPU.

Other features of the 16550 include:

- Programmable baud rate, character length, parity, and number of stop bits

- Automatic addition and removal of start, stop, and parity bits

- Independent and prioritized transmit, receive and status interrupts

- Transmitter clock output to drive receiver logic

- External receiver clock input

The following pages provide a brief summary of the internal registers available within the 16550 ACE. The registers are addressed as shown in figure 2 below.

DLAB	A2	A1	A0	REGISTER DESCRIPTION
0	0	0	0	Receive buffer (read)
				Transmit holding register (write)
0	0	0	1	Interrupt enable
x	0	1	0	Interrupt identification (read)
				FIFO control (write)
x	0	1	1	Line control
x	1	0	0	MODEM control
x	1	0	1	Line status
x	1	1	0	MODEM status
x	1	1	1	Scratch
1	0	0	0	Divisor latch (least significant)
1	0	0	1	Divisor latch (most significant)

Figure 2. Internal register map for 16550 ACE. DLAB is accessed through the Line Control Register.

## FUNCTIONAL DESCRIPTION

### A . INTERRUPT ENABLE REGISTER

D7	0	
D6	0	
D5	0	
D4	0	
D3	EDSSI	----- MODEM status
D2	ELSI	----- Receiver line status
D1	ETBEI	----- Transmitter holding register empty
D0	ERBFI	----- Received data available

Figure 3. Interrupt enable register bit definitions.

EDSSI - MODEM Status Interrupt:

When set (logic 1), enables interrupt on clear to send, data set ready, ring indicator, and data carrier detect.

ELSI - Receiver Line Status Interrupt:

When set (logic 1), enables interrupt on overrun, parity, and framing errors, and break indication.

ETBEI - Transmitter Holding Register Empty Interrupt:

When set (logic 1), enables interrupt on transmitter register empty.

ERBFI - Received Data Available Interrupt:

When set (logic 1), enables interrupt on received data available or FIFO trigger level.

**FUNCTIONAL DESCRIPTION**

**B . INTERRUPT IDENTIFICATION REGISTER**

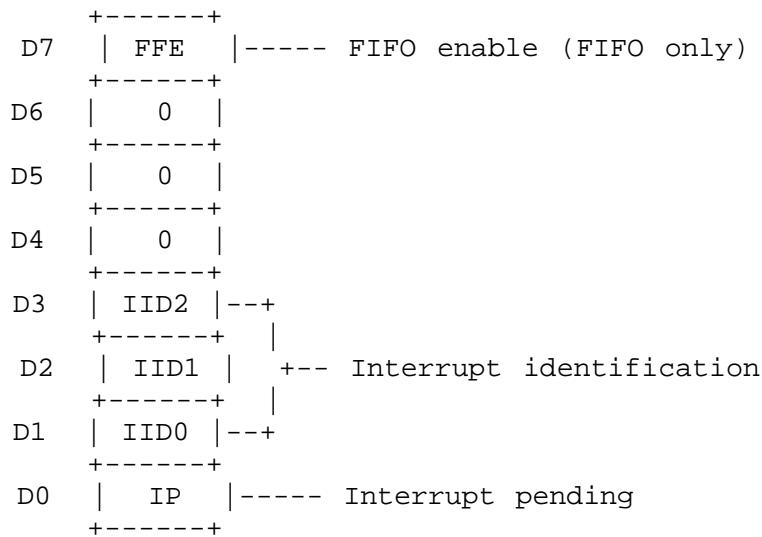

Figure 4. Interrupt identification register bit definitions.

- FFE - FIFO Enable:  
When logic 1, indicates FIFO mode enabled.
  
- IIDx - Interrupt Identification:  
Indicates highest priority interrupt pending if any. See IP and figure 5. NOTE: IID2 is always a logic 0 in character mode.
  
- IP - Interrupt Pending:  
When logic 0, indicates that an interrupt is pending and the contents of the interrupt identification register may be used to determine the interrupt source. See IIDx and figure 5.



**TIONAL DESCRIPTION**

IID2	IID1	IID0	IP	Priority	Interrupt Type
x	x	x	1	N/A	None
0	1	1	0	Highest	Receiver Line Status
0	1	0	0	Second	Received Data Ready
1	1	0	0	Second	Character Timeout (FIFO only)
0	0	1	0	Third	Transmitter Holding Register Empty
0	0	0	0	Fourth	MODEM Status

Figure 5. Interrupt identification bit definitions.

**Receiver Line Status:**

Indicates overrun, parity, or framing errors or break interrupts. The interrupt is cleared by reading the line status register.

**Received Data Ready:**

Indicates receive data available. The interrupt is cleared by reading the receiver buffer register.

**FIFO mode:**

Indicates the receiver FIFO trigger level has been reached. The interrupt is reset when the FIFO drops below the the trigger level.

**Character Timeout: (FIFO mode only)**

Indicates no characters have been removed from or input to the receiver FIFO for the last four character times and there is at least one character in the FIFO during this time. The interrupt is cleared by reading the receiver FIFO.

**Transmitter Holding Register Empty:**

Indicates the transmitter holding register is empty. The interrupt is cleared by reading the interrupt identification register or writing to the transmitter holding register.

**MODEM Status:**

Indicates clear to send, data set ready, ring indicator, or data carrier detect have changed state. The interrupt is cleared by reading the MODEM status register.

**C . FIFO CONTROL REGISTER**

D7	RXT1	--+	
	+-----+		+-- Receiver trigger
D6	RXT0	--+	
	+-----+		
D5	x	--+	
	+-----+		+-- Reserved
D4	x	--+	
	+-----+		
D3	DMAM	-----	DMA mode select
	+-----+		
D2	XRST	-----	Transmit FIFO reset
	+-----+		
D1	RRST	-----	Receive FIFO reset
	+-----+		
D0	FE	-----	FIFO enable
	+-----+		

Figure 6. FIFO control register bit definitions.

RXTx - Receiver FIFO Trigger Level:  
 Determines the trigger level for the FIFO interrupt as given in figure 7 below.

RXT1 RXT0		RCVR FIFO Trigger level (bytes)
0	0	1
0	1	4
1	0	8
1	1	14

Figure 7. FIFO trigger levels.

DMAM - DMA Mode Select:  
 When set (logic 1), RxDY and TxRDY change from mode 0 to mode 1. (DMA mode not supported on DS-2000.)

XRST - Transmit FIFO Reset:  
 When set (logic 1), all bytes in the transmitter FIFO are cleared and the counter is reset. The shift register is not cleared. XRST is self-clearing.

## FUNCTIONAL DESCRIPTION

- RRST - Receive FIFO Reset:  
When set (logic 1), all bytes in the receiver FIFO are cleared and the counter is reset. The shift register is not cleared. RRST is self-clearing.
- FE - FIFO Enable:  
When set (logic 1), enables transmitter and receiver FIFOs. When cleared (logic 0), all bytes in both FIFOs are cleared. This bit must be set when other bits in the FIFO control register are written to or the bits will be ignored.

### D . LINE CONTROL REGISTER

D7	DLAB	-----	Divisor latch access bit
D6	BKN	-----	Break control
D5	STKP	-----	Stick parity
D4	EPS	-----	Even parity select
D3	PEN	-----	Parity enable
D2	STB	-----	Number of stop bits
D1	WLS1	--+	Word length select
D0	WLS0	--+	

Figure 8. Line Control Register bit definitions.

- DLAB - Divisor Latch Access Bit:  
DLAB must be set to logic 1 to access the baud rate divisor latches. DLAB must be set to logic 0 to access the receiver buffer, transmitting holding register and interrupt enable register.
- BKN - Break Control:  
When set (logic 1), the serial output (SOUT) is forced to the spacing state (logic 0).

**FUNCTIONAL DESCRIPTION**

- STKP - Stick Parity:  
 Forces parity to logic 1 or logic 0 if parity is enabled. See EPS, PEN, and figure 9.
- EPS - Even Parity Select:  
 Selects even or odd parity if parity is enabled. See STKP, PEN, and figure 9.
- PEN - Parity Enable:  
 Enables parity on transmission and verification on reception. See EPS, STKP, and figure 9.

STKP	EPS	PEN	Parity
x	x	0	None
0	0	1	Odd
0	1	1	Even
1	0	1	Logic 1
1	1	1	Logic 0

Figure 9. 16550 parity selections.

- STB - Number of Stop Bits:  
 Sets the number of stop bits transmitted. See WLSx and figure 10.
- WLSx - Word Length Select:  
 Determines the number of bits per transmitted word. See STB and figure 10.

STB	WLS1	WLS0	Word length	Stop bits
0	0	0	5 bits	1
0	0	1	6 bits	1
0	1	0	7 bits	1
0	1	1	8 bits	1
1	0	0	5 bits	1½
1	0	1	6 bits	2
1	1	0	7 bits	2
1	1	1	8 bits	2

Figure 10. Word length and stop bit selections.

**FUNCTIONAL DESCRIPTION**

**E . MODEM CONTROL REGISTER**

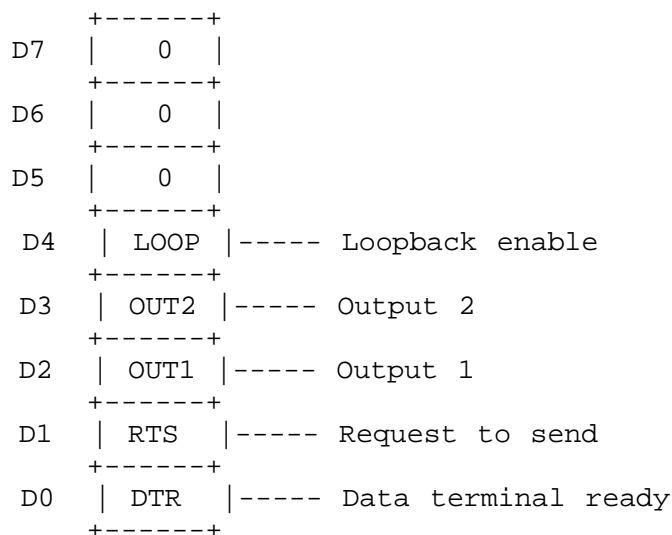

Figure 11. MODEM control register bit definitions.

**LOOP - Loopback Enable:**

When set (logic 1), the transmitter shift register is connected to the receiver shift register and the MODEM control inputs are connected to the MODEM control outputs. All characters transmitted are immediately received to verify transmit and receive data paths. Transmit and receive interrupts still operate normally but MODEM control interrupts are now controlled by the MODEM control register.

Bits OUT2, OUT1, RTS, and DTR perform identical functions on their respective outputs. When these bits are set (logic 1) in the register, the associated output is forced to a logic 0. When cleared (logic 0), the output is forced to logic 1.

**OUT2 - Output 2:**

Controls the OUT2 output as described above. Used for interrupt enable. See section VII.

**OUT1 - Output 1:**

Controls the OUT1 output as described above. Unused on DS-2000.

**RTS - Request To Send:**

Controls the RTS output as described above.

**DTR - Data Terminal Ready:**

Controls the DTR output as described above. Used for half-duplex control. See section IX.

## FUNCTIONAL DESCRIPTION

### F . LINE STATUS REGISTER

D7	FFRX	-----	Error in FIFO RCVR (FIFO only)
D6	TEMT	-----	Transmitter empty
D5	THRE	-----	Transmitter holding register empty
D4	BI	-----	Break interrupt
D3	FE	-----	Framing error
D2	PE	-----	Parity error
D1	OE	-----	Overrun error
D0	DR	-----	Data ready

Figure 12. Line status register bit definitions.

FFRX - FIFO Receiver Error:

Always logic 0 in character mode.

FIFO mode:

Indicates one or more parity errors, framing errors, or break indications in the receiver FIFO. FFRX is reset by reading the line status register.

TEMT - Transmitter Empty:

Indicates the transmitter holding register (or FIFO) and the transmitter shift register are empty and are ready to receive new data. TEMT is reset by writing a character to the transmitter holding register.

THRE - Transmitter Holding Register Empty:

Indicates the transmitter holding register (or FIFO) is empty and it is ready to accept new data. THRE is reset by writing data to the transmitter holding register (or FIFO).

## FUNCTIONAL DESCRIPTION

Bits BI, FE, PE, and OE are the sources of receiver line status interrupts. The bits are reset by reading the line status register. In FIFO mode, these bits are associated with a specific character in the FIFO and the exception is revealed only when that character reaches the top of the FIFO.

- BI - Break Interrupt:  
Indicates the receive data input has been in the spacing state (logic 0) for longer than one full word transmission time.
- FIFO mode:  
Only one zero character is loaded into the FIFO and transfers are disabled until SIN goes to the mark state (logic 1) and a valid start bit is received.
- FE - Framing Error:  
Indicates the received character had an invalid stop bit. The stop bit following the last data or parity bit was a 0 bit (spacing level).
- PE - Parity Error:  
Indicates that the received data does not have the correct parity.
- OE - Overrun Error:  
Indicates the receive buffer was not read before the next character was received and the character is destroyed.
- FIFO mode:  
Indicates the FIFO is full and another character has been shifted in. The character in the shift register is destroyed but is not transferred to the FIFO.
- DR - Data ready:  
Indicates data is present in the receive buffer or FIFO. DR is reset by reading the receive buffer register or receiver FIFO.

## FUNCTIONAL DESCRIPTION

### G . MODEM STATUS REGISTER

	+-----+	
D7	DCD	----- Data carrier detect
	+-----+	
D6	RI	----- Ring indicator
	+-----+	
D5	DSR	----- Data set ready
	+-----+	
D4	CTS	----- Clear to send
	+-----+	
D3	DDCD	----- Delta data carrier detect
	+-----+	
D2	TERI	----- Trailing edge ring indicator
	+-----+	
D1	DDSR	----- Delta data set ready
	+-----+	
D0	DCTS	----- Delta clear to send
	+-----+	

Figure 13. MODEM status register bit definitions.

DCD - Data Carrier Detect:  
Complement of the DCD input.

RI - Ring Indicator:  
Complement of the RI input.

DSR - Data Set Ready:  
Complement of the DSR input.

CTS - Clear To Send:  
Complement of the CTS input.

Bits DDCD, TERI, DDSR, and DCTS are the sources of MODEM status interrupts. These bits are reset when the MODEM status register is read.

DDCD - Delta Data Carrier Detect:  
Indicates the Data Carrier Detect input has changed state.

TERI - Trailing Edge Ring Indicator:  
Indicates the Ring Indicator input has changed from a low to a high state.

DDSR - Delta Data Set Ready:  
Indicates the Data Set Ready input has changed state.

DCTS - Delta Clear To Send:  
Indicates the Clear to Send input has changed state.



## **FUNCTIONAL DESCRIPTION**

### **H. SCRATCHPAD REGISTER**

This register is not used by the 16550. It may be used by the programmer for data storage.

### **IV. FIFO INTERRUPT MODE OPERATION**

1. The receive data interrupt is issued when the FIFO reaches the trigger level. The interrupt is cleared as soon as the FIFO falls below the trigger level.
2. The interrupt identification register's receive data available indicator is set and cleared along with the receive data interrupt above.
3. The data ready indicator is set as soon as a character is transferred into the receiver FIFO and is cleared when the FIFO is empty.

### **V. BAUD RATE SELECTION**

The 16550 UART determines the baud rate of the serial output from a combination of the clock input frequency and the value written to the divisor latches. Standard PC, PC/XT, PC/AT, and PS/2 serial interfaces use an input clock of 1.8432 MHz. To increase versatility, the DS-2000 uses an 18.432 MHz clock and a frequency divider circuit to produce the standard clock frequency.

Jumper block J1 is used to set the frequency of the 16550. It may be connected to divide the clock input by 1, 2, 5, or 10. For compatibility, J1 should be configured to divide by 10 as shown in figure 14(d).

**AUD RATE SELECTION**

Figure 14. Input clock frequency options. For compatibility, the jumper should be set at ÷10 ( 18.432 MHz ÷ 10 = 1.8432 MHz ).

The baud rate may now be calculated using the equation

$$\text{baud rate} = \frac{\text{crystal frequency}}{16 \times \text{divider} \times \text{DL}}$$

where

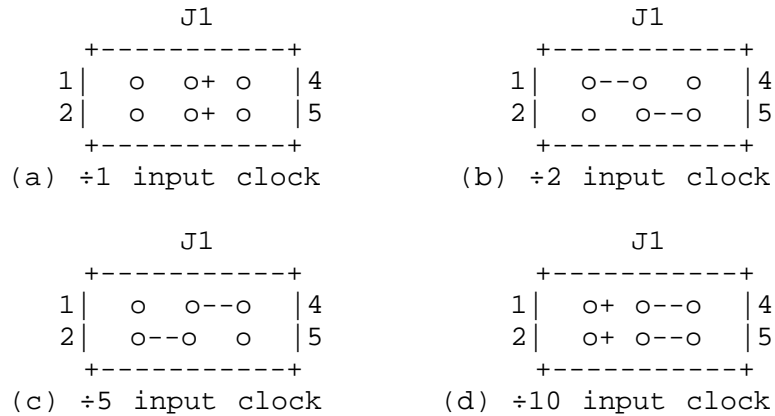
divider = the clock divider setting of jumper J1  
 DL = the value programmed into the baud rate divisor latches of the 16550.

Desired Baud Rate	Divisor Latch Value	Error Between Desired and Actual Value (%)
110	1047	0.026
300	384	-
1200	96	-
2400	48	-
4800	24	-
9600	12	-
19200	6	-
38400	3	-
56000	2	2.86

Figure 15. Divisor latch settings for common baud rates using a 1.8432 MHz input clock.

## ADDRESSING

### **VI. ADDRESSING**

Each channel of the DS-2000 uses 8 consecutive I/O address locations. The base addresses are independent but must begin on an even 8-byte boundary (xxx0H - xxx7H or xxx8H - xxxFH). The numbers xxx are controlled by the Programmable Option Select (POS) and address decoders to provide complete 16-bit addressing for each channel. Sixteen choices of base address are provided for each channel and include the eight addresses defined as SERIAL 1 through SERIAL 8. The remaining eight addresses are a constant 8000H offset from these values. A complete table of available addresses is given in figure 17. The 16550 utilizes its eight assigned addresses as shown in figure 2.

### **VII. INTERRUPTS**

The DS-2000 is capable of supporting four interrupt levels, IRQ 3,4,7 and 9. Each channel may select a separate interrupt or one may be shared by both channels. If interrupt sharing is used, the interrupt pending (IP) bit in the interrupt identification register should be used to test for the source of the interrupt.

#### **CAUTION:**

To maintain compatibility with earlier personal computer systems, the user defined output, OUT 2, is used as an external interrupt enable and must be set active for interrupts to be acknowledged. OUT 2 is accessed through the 16550's MODEM control register.

### **VIII. PROGRAMMABLE OPTION SELECT**

The IBM PS/2 family of computers using the MicroChannel bus structure utilize on board registers referred to as the Programmable Option Select (POS) registers to hold the adapter's configuration information. The first two POS registers hold a unique adapter identification number that has been issued to Qua Tech for the DS-2000. This number is defined in hardware and can not be changed. These registers are read only.

ABLE OPTION SELECT

The remaining POS registers are used for address and interrupt selections. These registers are programmed by the user through the IBM installation utility supplied with the PS/2. These registers are read/write but should not be written to by user software. The bit definitions of these registers are given in figures 16(a) and 16(b).

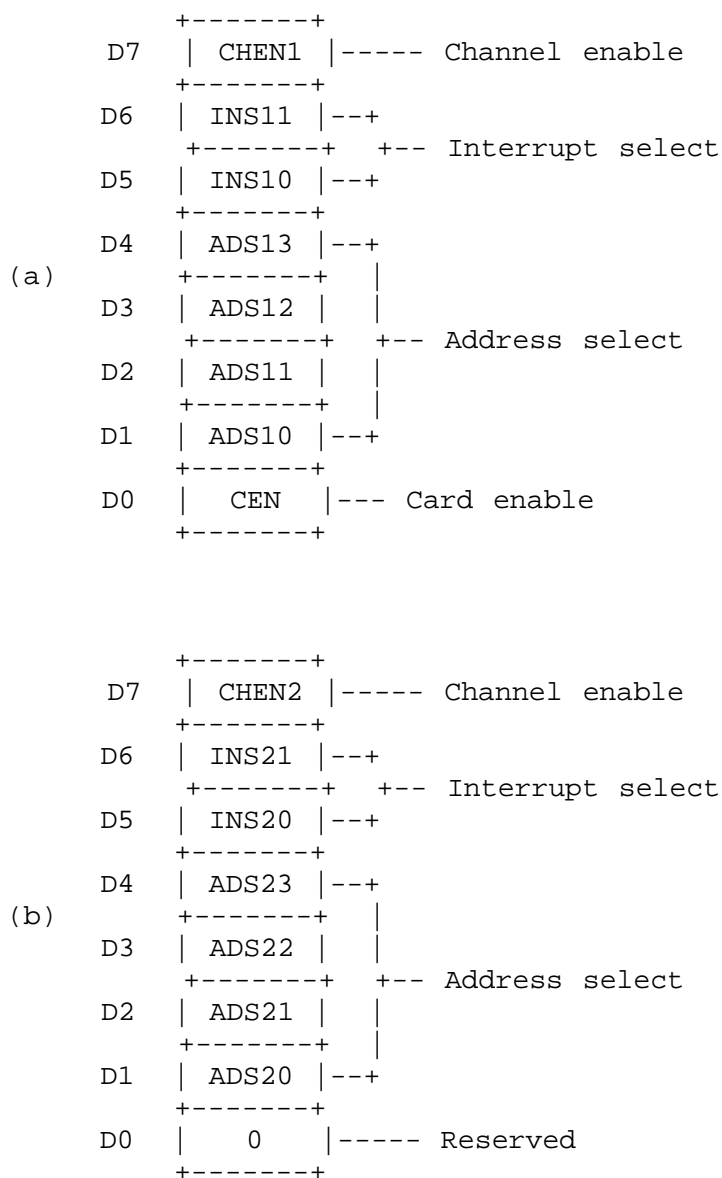

Figure 16. DS-2000 POS implementation.

(a) POS location 102H

(b) POS location 103H

**PROGRAMMABLE   OPTION   SELECT**

ADSx3	ADSx2	ADSx1	ADSx0	Base address
0	0	0	0	3F8H (Serial 1)
0	0	0	1	2F8H (Serial 2)
0	0	1	0	3220H (Serial 3)
0	0	1	1	3228H (Serial 4)
0	1	0	0	4220H (Serial 5)
0	1	0	1	4228H (Serial 6)
0	1	1	0	5220H (Serial 7)
0	1	1	1	5228H (Serial 8)
1	0	0	0	83F8H
1	0	0	1	82F8H
1	0	1	0	B220H
1	0	1	1	B228H
1	1	0	0	C220H
1	1	0	1	C228H
1	1	1	0	D220H
1	1	1	1	D228H

Figure 17. Available base addresses.

INSx1	INSx0	IRQ
0	0	3
0	1	4
1	0	7
1	1	9

Figure 18. Available interrupt levels.

PUT CONFIGURATIONS

**IX. OUTPUT CONFIGURATIONS**

Two sets of jumpers are implemented on the DS-2000 to control the auxiliary driver/receiver set. Jumpers J2 and J3 perform identical functions on channels 1 and 2 respectively.

The function of J2 and J3 is to control the source of the data exchanged on the auxiliary communication lines. The output sources are request to send (RTS), transmit clock (XCLK), and the auxiliary input (AUX IN). The inputs are clear to send (CTS) and receive clock (RCLK).

Transmission of RTS, when combined with reception of clear to send (CTS), allows for handshaking between the 16550 and a peripheral device. RTS is transmitted by connecting pins 5 and 6 of the jumper block (figure 21). CTS is received by connecting pins 1 and 2 (figure 21). The RTS/CTS handshake can be defeated by looping the RTS output back to the CTS input. This is accomplished by connecting pins 1 and 5 of the jumper block (figures 22 and 23).

RCLK is the input to the 16550 which controls the shift rate for the receiver portion of the chip. Generally this input is provided by connecting it to the XCLK output. This is performed by connecting pins 3 and 7 of the jumper block (figures 21 and 23). RCLK may be received from an external source by connecting pins 2 and 3 (figure 22).

Transmission of XCLK can be used to help synchronize communications with a peripheral or to provide a shift clock for a receiver. Transmission of XCLK is accomplished by connecting pins 6 and 7 of the jumper block (figure 22).

AUX IN is the auxiliary input from a peripheral device. Connecting AUX IN to AUX OUT provides a loopback mode of operation. That is, whatever is transmitted by the peripheral will be fed back to the peripheral. AUX IN/ AUX OUT loopback is implemented by connecting pins 2 and 6 of the jumper (figure 23).

## OUTPUT CONFIGURATIONS

The other function of J2 and J3 is to configure the communication channel in half or full duplex mode. Half duplex operation is achieved by connecting pins 4 and 8 of the jumper block (figure 23). This allows the transmitter to be enabled and disabled using the data terminal ready (DTR) output in the modem control register. Full duplex operation is restored by removing the jumper on pins 4 and 8 (figures 21 and 22).

Jumper J4 selects the level of DTR that enables the transmitter outputs. When the enable control line is connected to +DTR (factory configuration), writing a logic 1 to the DTR bit location in the MODEM control register enables transmission. Writing a logic 0 disables transmission. In this configuration, transmission is disabled on power-up.

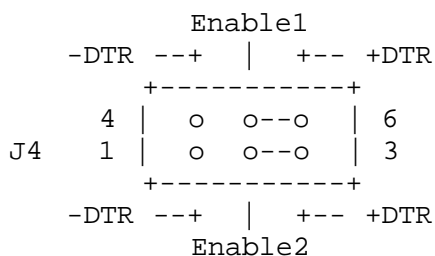

To maintain compatibility with some other Quatech products, the enable control line can be connected to -DTR. In this configuration, writing a logic 0 to the DTR bit location in the MODEM control register enables transmission, logic 1 disables transmission. In this configuration, transmission is enabled on power-up.

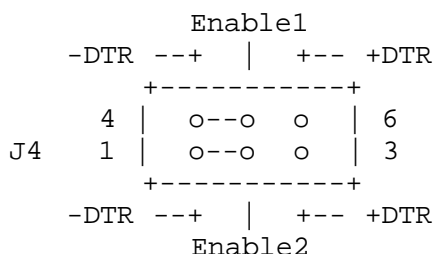

### **CAUTION:**

When operating in half duplex mode, the transmitter must be disabled before receiving any information. Failure to do so will result in two output drivers being connected together which may cause damage to the DS-2000, the computer and the peripheral equipment.

## OUTPUT CONFIGURATIONS

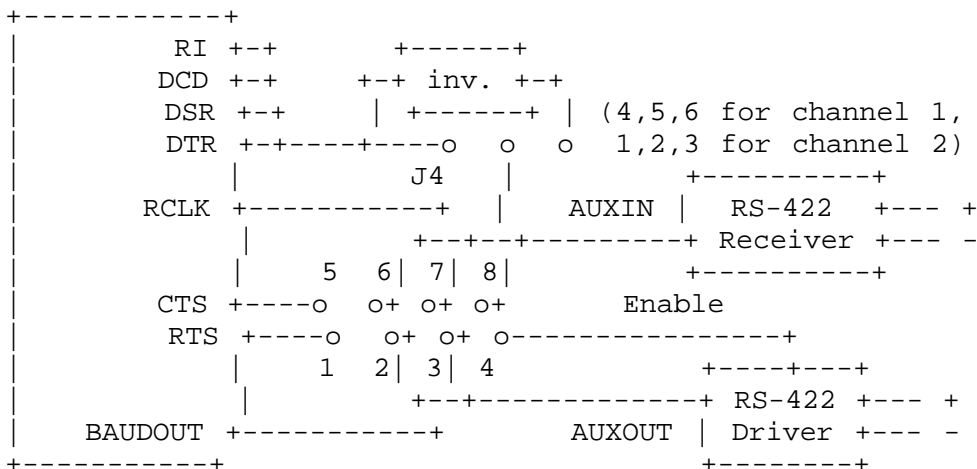
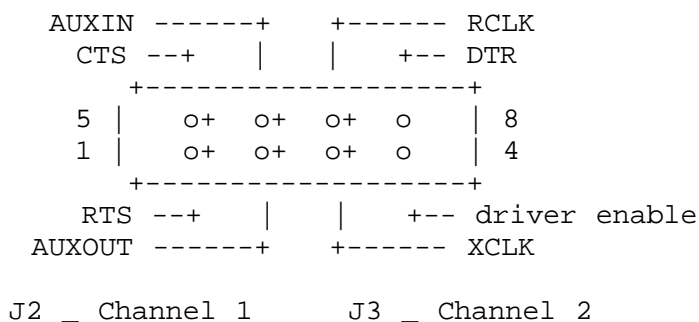

Figure 19. Output control block diagram.



Function	Connect	Disconnect
RTS/CTS loopback *	1-5	1-2
Transmit RTS	5-6	6-7
Receive CTS	1-2	2-3
RCLK/XCLK loopback *	3-7	2-3
Transmit XCLK	6-7	5-6
Receive RCLK	2-3	1-2
AUX OUT/AUX IN loopback *	2-6	5-6,6-7
Half duplex	4-8	
Full duplex *		4-8

\*Indicates factory jumper settings.

Figure 20. J2/J3 jumper layout and settings.



**OUTPUT CONFIGURATIONS**

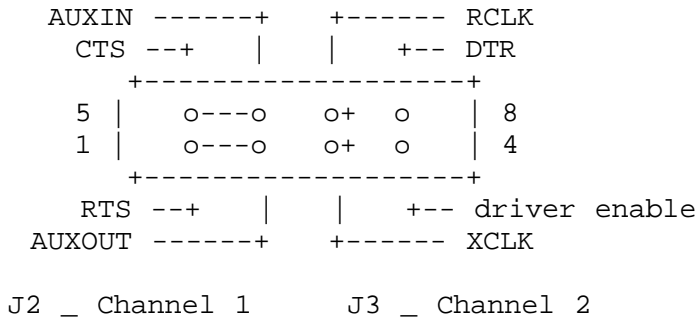

Figure 21. Jumper configuration showing:  
 (1) RTS transmission  
 (2) CTS reception  
 (3) XCLK/RCLK loopback  
 (4) Full duplex operation

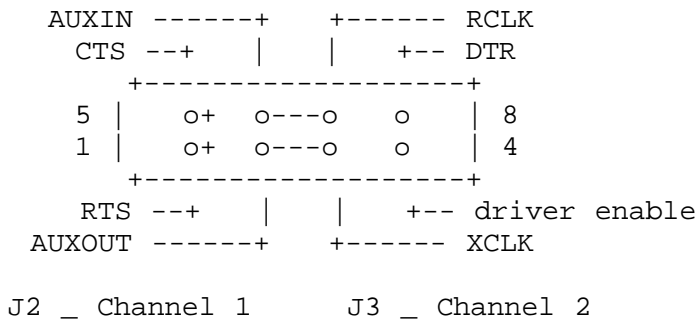

Figure 22. Jumper configuration showing:  
 (1) RTS/CTS loopback  
 (2) XCLK transmission  
 (3) RCLK reception  
 (4) Full duplex operation

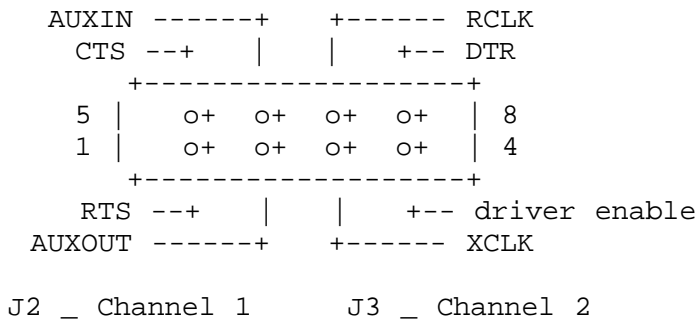

Figure 23. Jumper configuration showing:  
 (1) RTS/CTS loopback  
 (2) XCLK/RCLK loopback  
 (3) AUX OUT/AUX IN loopback  
 (4) Half duplex operation

TERNAL CONNECTIONSX. EXTERNAL CONNECTIONS

Connections to peripheral equipment are made via a female D-9 connector. A pin-out of the D-9 connector and a detailed description of each output signal is illustrated in figures 24 and 25.

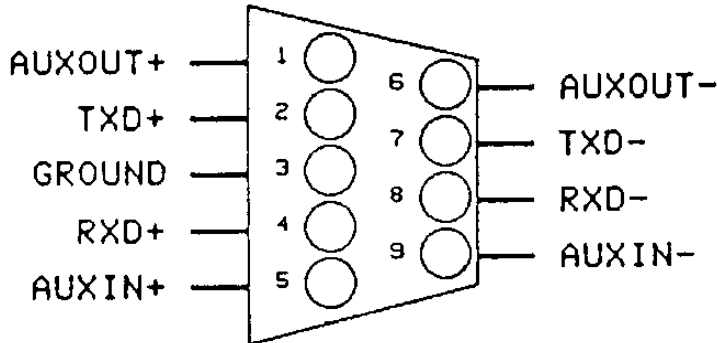

Figure 24. D-9 output configuration.

PIN	SIGNAL	DESCRIPTION
1	AUX OUT+	When combined with AUX OUT-, provides the auxiliary channel output defined by jumpers J2/J3.
2	DATA OUT+	When combined with DATA OUT-, provides the serial data output.
3	SIGNAL GND	
4	DATA IN+	When combined with DATA IN-, provides the serial data input.
5	AUX IN+	When combined with AUX IN-, provides the auxiliary channel input defined by jumpers J2/J3.
6	AUX OUT-	See AUX OUT+
7	DATA OUT-	See DATA OUT+
8	DATA IN-	See DATA IN+
9	AUX IN-	See AUX IN+

Figure 25. D-9 signal definitions.

## INSTALLATION

### **XI. INSTALLATION**

Make sure there is a copy of the original reference diskette available. This diskette must be modified to accept any option adapters.

1. Turn unit off.
2. Remove system cover as instructed in the IBM Quick Reference Guide.
3. Insert adapter into any vacant slot following the guidelines for installing an optional adapter in the IBM Quick Reference Guide.
4. Replace system cover.
5. Turn unit on and insert copy of reference diskette into drive A.
6. Respond "N" to automatic configuration.
7. Select "Copy an option diskette" and follow copying instructions.
8. Select "Set configuration"
9. Select "Change configuration" or "Run automatic configuration" and follow instructions.

After the initial installation, the reference diskette will contain the configuration file for the DS-2000. Subsequent re-installation or address changes may omit step 7 and a "Y" response may be given in step 6 (automatically configure system) if desired.

### **XII. SPECIFICATIONS**

Bus interface: IBM MicroChannel 16-bit bus  
Controllers: 2 - 16550 Asynchronous Communication Elements (ACEs)  
RS-422 interface: 2 - D-9 connectors (female)  
Transmit drivers: MC3486 or compatible  
Receive buffers: MC3487 or compatible  
I/O Address range: See figure 17  
Interrupt levels: IRQ 3,4,7,9

Power requirements:

$I_T$	$I_{MS}$	Supply
630mA	720mA	+5 Volts
--	--	+12 Volts
--	--	-12 Volts

$I_T$  - Typical adapter current

$I_{MS}$  - Maximum statistical adapter current

## Free Manuals Download Website

<http://myh66.com>

<http://usermanuals.us>

<http://www.somanuals.com>

<http://www.4manuals.cc>

<http://www.manual-lib.com>

<http://www.404manual.com>

<http://www.luxmanual.com>

<http://aubethermostatmanual.com>

Golf course search by state

<http://golfingnear.com>

Email search by domain

<http://emailbydomain.com>

Auto manuals search

<http://auto.somanuals.com>

TV manuals search

<http://tv.somanuals.com>