

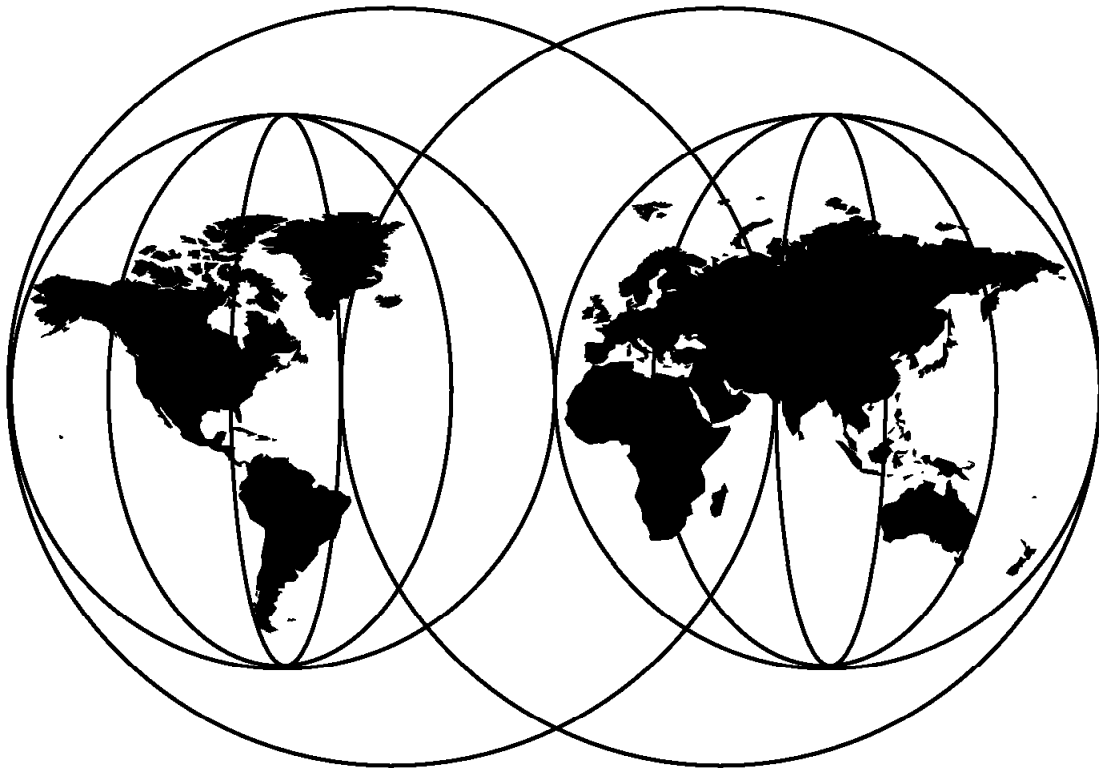

RAMAC Virtual Array, Peer-to-Peer Remote Copy, and IXFP/SnapShot for VSE/ESA

Alison Pate Dionisio Dychioco Guenter Rebmann Bill Worthington



International Technical Support Organization

<http://www.redbooks.ibm.com>

This book was printed at 240 dpi (dots per inch). The final production redbook with the RED cover will be printed at 1200 dpi and will provide superior graphics resolution. Please see "How to Get ITSO Redbooks" at the back of this book for ordering instructions.

SG24-5360-00



International Technical Support Organization

SG24-5360-00

**RAMAC Virtual Array,
Peer-to-Peer Remote Copy,
and IXFP/SnapShot for VSE/ESA**

January 1999

Take Note!

Before using this information and the product it supports, be sure to read the general information in Appendix E, "Special Notices" on page 65.

First Edition (January 1999)

This edition applies to Version 6 of VSE Central functions, Program Number 5686-066, Version 2, Release 3.1 of VSE/ESA, Program Number 5590-VSE, and Version 1, Release 16 of Initialize Disk (ICKDSF), Program Number 5747-DS2 for use with the VSE/ESA operating system.

Comments may be addressed to:

IBM Corporation, International Technical Support Organization
Dept. QXXE Building 80-E2
650 Harry Road
San Jose, California 95120-6099

When you send information to IBM, you grant IBM a non-exclusive right to use or distribute the information in any way it believes appropriate without incurring any obligation to you.

© **Copyright International Business Machines Corporation 1999. All rights reserved.**

Note to U.S. Government Users — Documentation related to restricted rights — Use, duplication or disclosure is subject to restrictions set forth in GSA ADP Schedule Contract with IBM Corp.

Contents

| | |
|---|------|
| Preface | vii |
| The Team That Wrote This Redbook | vii |
| Comments Welcome | viii |
| | |
| Chapter 1. The IBM RAMAC Virtual Array | 1 |
| 1.1 What Is an IBM RAMAC Virtual Array? | 1 |
| 1.1.1 Overview of RVA and the Virtual Disk Architecture | 1 |
| 1.1.2 Log Structured File | 1 |
| 1.1.3 Data Compression and Compaction | 2 |
| 1.2 VSE/ESA Support for the RVA | 3 |
| 1.2.1 What Is IXFP/SnapShot for VSE/ESA? | 3 |
| 1.2.2 What Is SnapShot? | 3 |
| 1.2.3 What Is IXFP? | 4 |
| 1.3 What Is Peer-to-Peer Remote Copy? | 5 |
| | |
| Chapter 2. RVA Benefits for VSE/ESA | 7 |
| 2.1 RVA Simplifies Your Storage Management | 7 |
| 2.1.1 Disk Capacity | 7 |
| 2.1.2 Administration | 8 |
| 2.1.3 IXFP | 8 |
| 2.2 Batch Window Improvement | 8 |
| 2.2.1 RAMAC Virtual Array | 9 |
| 2.2.2 IXFP/SnapShot for VSE/ESA | 9 |
| 2.3 Application Development | 10 |
| 2.4 RVA Data Availability | 10 |
| 2.4.1 Hardware | 10 |
| 2.4.2 SnapShot | 11 |
| 2.4.3 PPRC | 11 |
| | |
| Chapter 3. VSE/ESA Support for the RVA | 13 |
| 3.1 Prerequisites | 13 |
| 3.2 Volumes | 14 |
| 3.3 Host Connection | 14 |
| 3.3.1 VSE/ESA Input/Output Configuration Program | 14 |
| 3.4 ICKDSF | 15 |
| 3.4.1 Volume Minimal Init | 15 |
| 3.4.2 Partial Disk Minimal Init | 15 |
| | |
| Chapter 4. IXFP/SnapShot for VSE/ESA | 17 |
| 4.1 IXFP SNAP | 21 |
| 4.1.1 A Full Volume | 21 |
| 4.1.2 A Range of Cylinders | 23 |
| 4.1.3 A Non-VSAM File | 24 |
| 4.2 IXFP DDSR | 25 |
| 4.2.1 Expired Files | 25 |
| 4.2.2 A Total Volume | 26 |
| 4.2.3 A Range of Cylinders | 26 |
| 4.2.4 A Specified File | 27 |
| 4.3 IXFP REPORT | 27 |
| 4.3.1 Device Detail Report | 29 |
| 4.3.2 Device Summary Report | 31 |

| | |
|--|-----------|
| 4.3.3 Subsystem Summary Report | 31 |
| Chapter 5. Peer-to-Peer Remote Copy | 33 |
| 5.1 PPRC and VSE/ESA Software Requirements | 34 |
| 5.2 PPRC Hardware Requirements | 35 |
| 5.3 Invoking peer-to-peer remote copy | 35 |
| 5.4 SnapShot Considerations | 36 |
| 5.4.1 Primary Devices of a PPRC Pair | 36 |
| 5.4.2 Secondary Devices of a PPRC Pair | 36 |
| 5.5 Examples of PPRCOPY Commands | 36 |
| 5.5.1 Setting Up PPRC Paths and Pairs | 37 |
| 5.5.2 Recovering from a Primary Site Failure | 37 |
| 5.5.3 Recovering from a Secondary Site Failure | 38 |
| 5.5.4 Deleting PPRC Pairs and Paths | 38 |
| 5.6 Physical Connections to the RVA | 38 |
| 5.6.1 Determining the Logical Control Unit Number for RVA | 39 |
| 5.6.2 Determining the Channel Connection Address | 39 |
| Appendix A. RVA Functional Device Configuration | 41 |
| Appendix B. IXFP Command Examples | 43 |
| B.1 SNAP Command | 43 |
| B.1.1 Syntax | 43 |
| B.1.2 Using SnapShot to Copy One Volume to Another | 45 |
| B.1.3 Using SnapShot to Copy a File from One Volume to Another | 47 |
| B.1.4 Using SnapShot to Copy Files with Relocation | 47 |
| B.1.5 Other Uses of SnapShot | 48 |
| B.2 DDSR Command | 49 |
| B.2.1 Syntax | 49 |
| B.2.2 Using DDSR to Delete a Single Data Set | 50 |
| B.2.3 Using DDSR to Delete the Contents of a Volume | 50 |
| B.2.4 Using DDSR to Delete the Free Space on an RVA | 51 |
| B.3 Report Command | 52 |
| B.3.1 Syntax | 52 |
| B.3.2 Reporting on the Capacity of a Single Volume | 53 |
| B.3.3 Reporting on the Capacity of Multiple Volumes | 53 |
| B.3.4 Reporting on the Capacity of the RVA Subsystem | 53 |
| B.4 IXFP/SnapShot Setup Job Streams | 54 |
| Appendix C. VSE/VSAM Considerations | 59 |
| C.1 Backing up VSAM Volumes | 60 |
| Appendix D. IOCDS Example | 63 |
| Appendix E. Special Notices | 65 |
| Appendix F. Related Publications | 67 |
| F.1 International Technical Support Organization Publications | 67 |
| F.2 Redbooks on CD-ROMs | 67 |
| F.3 Other Publications | 67 |
| How to Get ITSO Redbooks | 69 |
| IBM Redbook Fax Order Form | 70 |
| Index | 71 |

ITSO Redbook Evaluation 73

Preface

This redbook provides a foundation for understanding VSE/ESA's support for the IBM 9393 RAMAC Virtual Array (RVA). It covers existing support and the recently available IXFP/SnapShot for VSE/ESA and peer-to-peer remote copy support for the RVA. It also covers using IXFP/SnapShot for VSE/ESA for VSE/VSAM.

The redbook is intended for use by IBM client representatives, IBM technical specialists, IBM Business Partners, and IBM customers who are planning to implement IXFP/SnapShot for VSE/ESA on the RVA.

The Team That Wrote This Redbook

This redbook was produced by a team of specialists from around the world working at the International Technical Support Organization, San Jose Center.

Alison Pate is a project leader in the International Technical Support Organization, San Jose Center. She joined IBM in the UK after completing an MSc in Information Technology. A large-systems specialist since 1990, Alison has eight years of practical experience in using and implementing IBM DASD solutions. She has acted as a consultant to some of the largest, leading-edge customers in the United Kingdom—providing technical support and guidance to their key business projects.

Guenter Rebmann is a DASD HW Support Specialist in Germany. He joined IBM in 1983 as a Customer Engineer for large system customers. Since 1993 Guenter has worked in the DASD-EPDG (EMEA Product Support Group) in Mainz, Germany. His area of expertise is large system hardware products.

Dionisio Dychioco III is a Technical Support Manager in the Philippines. He has 19 years of experience in data processing, including 17 years in technical support in the IBM mainframe environment. Dionisio has worked at the Far East Bank & Trust Co. for 12 years. His areas of expertise include MVS, VSE, and mainframe-PC connectivity.

Bill Worthington is a Consulting IT Technical Specialist in the United States. He has 38 years of experience in data processing, including 34 years in technical sales support within IBM. His areas of expertise include high-end disk storage products as well as VSE/ESA and VM/ESA. Bill has been in his current position supporting RAMAC DASD products since 1995.

Thanks to the following people for their invaluable contributions to this project:

Janet Anglin, Storage Systems Division, San Jose
Maria Sueli Almeida, International Technical Support Organization, San Jose
Fred Borchers, International Technical Support Organization, Poughkeepsie
Jack Flynn, Storage Systems Division, San Jose
Bob Haimowitz, International Technical Support Organization, Poughkeepsie
Dan Janda, Jr., Advanced Technical Support, Endicott
Teresa Leamon, Storage Systems Division, San Jose
Axel Pieper, VSE Development, Boeblingen, Germany
Hanns-Joachim Uhl, VSE Development, Boeblingen, Germany

Comments Welcome

Your comments are important to us!

We want our redbooks to be as helpful as possible. Please send us your comments about this or other redbooks in one of the following ways:

- Fax the evaluation form found in "ITSO Redbook Evaluation" on page 73 to the fax number shown on the form.
- Use the online evaluation form found at <http://www.redbooks.ibm.com/>
- Send your comments in an Internet note to redbook@us.ibm.com

Chapter 1. The IBM RAMAC Virtual Array

In this chapter we describe the RAMAC Virtual Array (RVA) and the support that VSE/ESA delivers for it.

1.1 What Is an IBM RAMAC Virtual Array?

We explain functions here on a level that is needed to understand how data is stored and organized on an RVA. If you would like more detailed descriptions of this interesting virtual disk architecture, see the redbook entitled *IBM RAMAC Virtual Array*, SG24-4951.

1.1.1 Overview of RVA and the Virtual Disk Architecture

Traditional storage subsystems such as the 3990 and 3390 use the count key data (CKD) architecture. The CKD architecture defines how and where on the disk device the data is physically stored. Any updates to the data are written directly to the same position on the physical disk from which the updated data was read. This is referred to as *update in place*.

IBM's RVA provides a high-availability, high-performance storage solution thanks to its revolutionary *virtual disk architecture*. To the host, the RVA appears as up to four traditional 3990 storage controls, with up to 256 3380 or 3390 volumes—64 functional volumes on each 3990. These devices do not physically exist in the subsystem and are referred to as *functional devices*. Physically, the subsystem contains RAID 6-protected arrays of fixed block architecture (FBA) disk devices.

1.1.2 Log Structured File

The RAID-protected FBA disk arrays that make up the RVA's physical disk space are sequentially filled with data. New and updated data is placed at the end of the file, as it is on a sequential or log file. We call this architecture a *log structured file*.

Updates leave areas in the log file that are no longer needed. A microcode process called *freespace collection* ensures that these areas are put back so that there is always enough freespace for writing. This process runs as a background task. You can control the freespace by observing the net capacity load (NCL) of the RVA and using the IBM Extended Facilities Product (IXFP) program. See the RVA redbook entitled *IBM RAMAC Virtual Array* for more information. The RVA's physical disk space typically should be kept below 75% NCL. Above that level, the freespace collection process runs with higher priority, and performance degradation may result. A service information message (SIM) informs operators when this threshold is reached.

The following tables are used to map the tracks of functional devices to the FBA blocks related to those tracks:

- *Functional device table*

The functional device table (FDT) holds the information about the functional volumes that have been defined to the RVA.

- *Functional track directory*

The functional track directory (FTD) is the collective name for two tables that together map each functional track to an area in the RVA's physical storage:

- *Functional track table*

The functional track table (FTT) contains the host-related pointers, that is, the functional-device-related track pointers of the FTD.

- *Track number table*

The track number table (TNT) contains the back-end data pointers of the FTD. A *reference counter* is also part of this table.

Although the FTD consists of two tables, we discuss it as one entity (see Figure 1). In fact, each functional track has an entry in the FDT. If a functional track contains data, its associated FTD entry has a pointer to the FBA block where the data starts. The data of a functional track may fit on one or more FBA blocks.

If the data of a functional track is updated, the RVA puts the new data in a new place in the log structured file, and the FTD entry points to the new data location. There is no update in place.

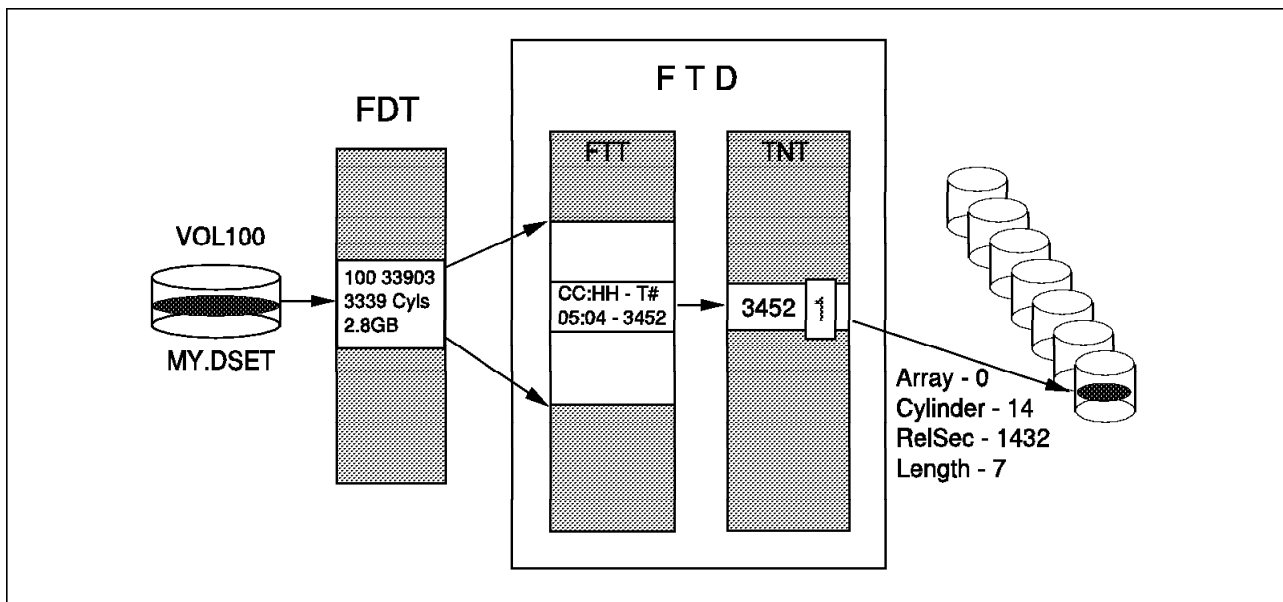

Figure 1. The RAMAC Virtual Array Tables

1.1.3 Data Compression and Compaction

All data in the RVA is compressed; compression occurs when data enters an RVA. In addition, the gaps between the records, as they appear on the CKD devices, are removed before the data is written to disk. Similarly, the unused space at the end of a track is removed. This is called *compaction*. The compression and compaction ratio depends on the nature of the data. Experience shows that RVA customers can achieve an overall compression and compaction ratio of 3.6:1.

Data compression speeds up the transfer from and to the arrays. It increases the effectiveness of cache memory because when compressed more data can fit in cache.

1.2 VSE/ESA Support for the RVA

The RVA has been supported by VSE/ESA since its introduction. Because the RVA presents itself as logical 3380 or 3390 direct access storage devices (DASD) attached to a logical 3990 Model 3 storage control, releases of VSE/ESA supporting this logical environment have functioned with the RVA. However, until now, VSE/ESA has not provided SnapShot, deleted data space release (DDSR) or capacity reporting natively. It has depended on VM/ESA's IXFP and SnapShot to provide that benefit to VSE/ESA guests.

1.2.1 What Is IXFP/SnapShot for VSE/ESA?

IXFP/SnapShot for VSE/ESA is a feature of VSE Central Functions in conjunction with VSE/ESA Version 2, Release 3.1. It provides SnapShot, DDSR, and capacity reporting support for the RVA. OS/390 and VM/ESA provide two distinct products—IXFP and SnapShot—for supporting the RVA, whereas VSE/ESA has integrated many of the functions provided by these products into a single feature that implements the support in an Attention Routine command.

1.2.2 What Is SnapShot?

SnapShot, one of the three functions in IXFP/SnapShot for VSE/ESA, enables you to produce almost instantaneous copies of non-VSAM data sets, volumes, and data within CYLINDER ranges.

Note: Although not officially supported, VSAM data sets can be indirectly copied through techniques we discuss in Appendix C, "VSE/VSAM Considerations" on page 59.

The speed in copying is attained by exploiting the RVA's virtual disk architecture. Snapshot produces copies without data movement. We call making a copy with SnapShot a *snap*. The result of a SnapShot is also called a *snap*.

Conventional methods of copying data on DASD consist of making a physical copy of the data on either DASD or tape. Host processors, channels, tape, and DASD controllers are involved in these conventional copy processes. Copying may take a long time, depending on available system resources.

In the RVA's virtual disk architecture, a functional device is represented by a certain number of pointers in the FTD. Every used track has a pointer in the FTD to its back-end data. You *snap* a copy of the data by copying its FTD pointers. As you can imagine, snapping is a very fast process that takes seconds rather than minutes or hours. No data movement takes place, and no additional back-end physical space is used. Both FTD pointers, the original and the copy, point to the same physical data location (see Figure 2 on page 4). Notice too that the TNT entry now has a value of 2, which indicates that the data is in use by two logical volumes.

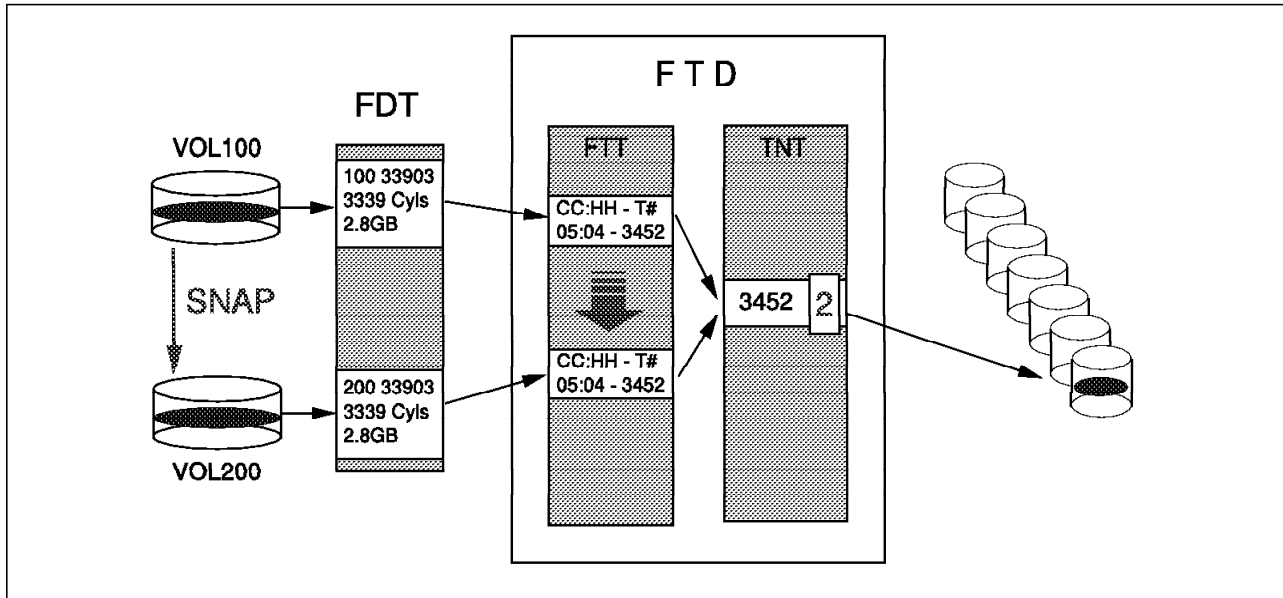

Figure 2. Data Snapping. SnapShot creates a logical copy by copying the FTD pointers.

Only when either the original or the copied track is updated is its associated FTD pointer changed to point to the new data location. The other FTD pointer remains unchanged. Additional space is needed in this case. As long as there is a pointer to a data block in the physical disk storage, the block cannot become free for the freespace collection process. A reference counter in the TNT prevents the block from becoming free.

Although the creation of the copy is a logical manipulation of pointers, the data exists on disk, so in this sense is not a logical copy. As far as the operating system is concerned, the two copies are completely independent of each other. On the RVA hardware side, the *snap* is a virtual copy of the data.

1.2.3 What Is IXFP?

The IXFP portion of IXFP/SnapShot for VSE/ESA provides two functions: DDSR and reporting.

1.2.3.1 Deleted Data Space Release

The RVA manages the freespace in the back-end storage by monitoring space that is no longer occupied by active data. This may be space formerly occupied by temporary files, such as DFSORT for VSE work files, or it may be space that previously held data that has been updated and written back to a different array track in the back-end storage of the RVA. The difference is that the RVA does not know that the sort work space is no longer needed without being explicitly told to release it into the free space pool.

The DDSR option of the IXFP operator command provides the ability to release this freespace back to the RVA. Using DDSR, allocated space can be returned to the RVA on a subsystem or volume basis. Individual files can also be deleted and their space returned. DDSR is done using the new IXFP Attention Routine command when space reclamation is needed. Either the operator can invoke the commands, or a job stream can include them.

1.2.3.2 Reporting Functions

The IXFP/SnapShot for VSE/ESA reporting function displays logical volume utilization, such as space allocated and data stored on the volume. It can also display a summary of the entire subsystem and its NCL, freespace, capacity allocated and used, and the compression and compaction ratio.

For the capacity management functions supported by OS/390 and VM/ESA, such as reconfiguring the DASD, adding or deleting volumes, and draining an array, you use the RVA's local operator panel.

1.3 What Is Peer-to-Peer Remote Copy?

We explain functions here on a level that is needed to understand how peer-to-peer remote copy (PPRC) functions on an RVA. If you would like more detailed descriptions of this data availability architecture, see the RVA redbook entitled *Implementing PPRC on RVA*, SG24-4951.

PPRC allows the synchronous copying of data from a primary RVA to one or more secondary RVAs at the same or a different location while providing enterprisewide data protection, availability, and ease of system management. The secondary site may be up to 43 km away from the primary. The synchronous nature of PPRC offers a full recovery solution while delivering the highest levels of data integrity and data availability for both operational and disaster recovery environments.

The availability of PPRC on the RVA Model T82 now places the RVA at the heart of mission-critical enterprise storage solutions—including remote site disaster recovery protection, high availability, and data migration capabilities.

Chapter 2. RVA Benefits for VSE/ESA

In this chapter we describe how VSE/ESA's support for the RVA assists in managing storage, affects batch window characteristics, improves application development, and increases the availability of data to the applications running on the host system.

2.1 RVA Simplifies Your Storage Management

The RVA virtual disk architecture has many benefits to simplify your storage management. In this section we discuss the improvements in storage management that the functions and features of the RVA provide.

The space management improvements come from; more effective space use from compression, minimizing administration, and ease of management using IXFP/SnapShot for VSE/ESA (see Figure 3).

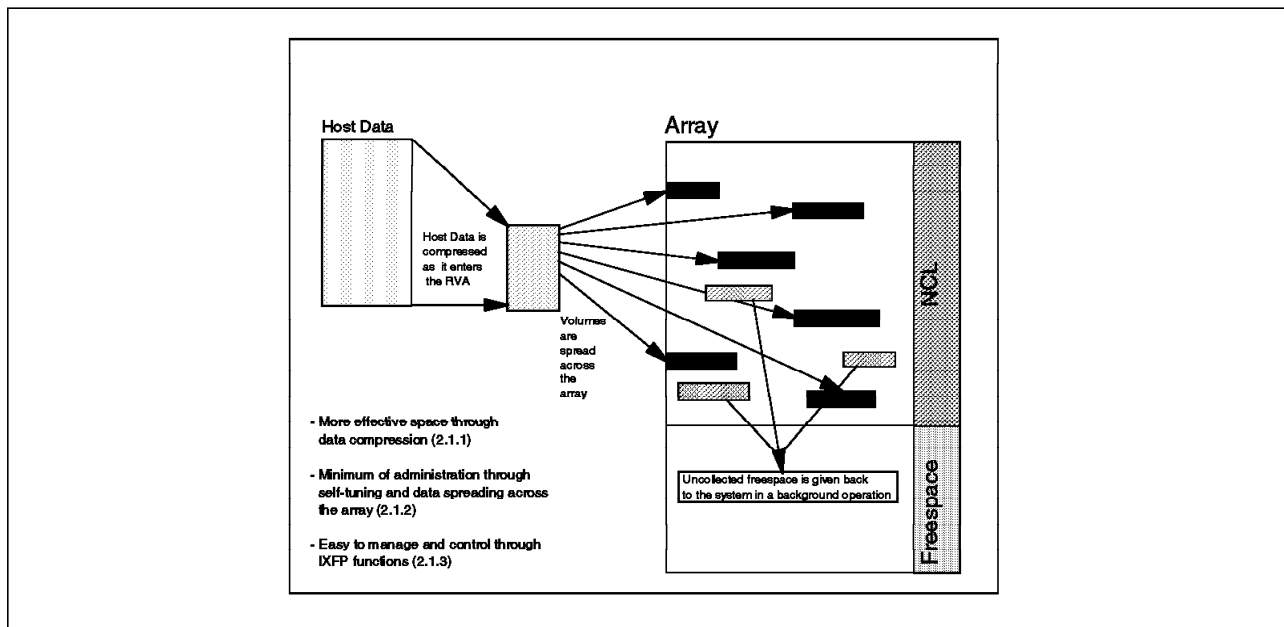

Figure 3. Space Management Improvements

2.1.1 Disk Capacity

The virtual disk architecture and the use of data compression enable you to store data more effectively in the arrays of the RVA than in a traditional disk architecture subsystem. The virtual disk architecture reduces the cost per megabyte in your subsystem and increases the internal transfer rate in the RVA.

There is no allocation of physical disk space for logical volumes, as there is in traditional subsystems, so unused disk space is not given away. When data is written to the RVA, the arrays are filled sequentially, independent of the volume or data set to which the data belongs. The logical capacity that you define is independent of the physical capacity that you have installed. Therefore you can define more logical volumes than you would be able to define in a traditional

disk architecture, for the same physical space. Thus you can spread data over more volumes to improve performance and data availability of the subsystem.

The hardware design of the RVA allows you to upgrade physical disk space to 726 GB without any subsystem outage time and without any change to the logical device configuration. Cache upgrades are also concurrent with subsystem operation. Therefore you have a high level of data availability and low subsystem outage time for planned configuration changes.

2.1.2 Administration

The subsystem administration activity is reduced for space management. Space management is simplified with the RVA, because there is no penalty for overallocation. Data placement activity is also reduced. With the use of the log structure file, the data from all volumes is spread across all physical disks in the array. This eliminates the requirement to separate data for availability or performance reasons, such as preventing high activity data sets, tables, or indexes from being placed on the same disk volumes.

When the RVA is installed, you can define up to 256 volumes as either 3390 or 3380 devices. This gives you flexibility in your configuration and eases migration from previous installed hardware. With the virtual disk architecture data management and tuning activities are minimized. Data is spread across all disks in the array, automatically balancing the I/O load. When data is updated it is written to another physical location in the array. As a result uncollected freespace is created, which the RVA recycles independently in a background routine to have it available for further use. This automatic freespace collection keeps the level of the NCL as low as possible without any intervention from space management, thus reducing the time and cost of storage management.

2.1.3 IXFP

With IXFP it is easy to manage the subsystem and monitor the NCL. With the use of IXFP SnapShot, the time expended to copy volumes, data sets, or files is considerably reduced. Backups can be done more often to increase the consistency and data availability of your system.

The IXFP reporting function provides information about the space utilization of a single RVA device or range of RVA devices. With the DDSR function of IXFP you can release expired files residing on all VSE-managed RVA volumes whose expiration date has been reached. You can process a complete volume, a cylinder range, or a specified file. Thus the RVA can manage subsystem freespace more efficiently than before.

2.2 Batch Window Improvement

Reducing the batch processing time increases the availability of online applications. RVA and IXFP/SnapShot for VSE/ESA help reduce batch processing time in several areas.

2.2.1 RAMAC Virtual Array

The RVA's virtual disk architecture enables performance improvement in batch processing. This new architecture, coupled with data compression and self-tuning capabilities, improves disk capacity utilization. Data from all logical volumes is written across all the physical disks the array. Automatic load balancing across the volumes occurs as data is written to the array. Further, the ability of the RVA to dynamically configure additional volumes of various sizes eliminates volume contention and thereby reduces I/O bottlenecks.

In the RVA, space that has never been allocated or is allocated but unused takes up no capacity. Data set size can increase and new files can be created with minimal need to reorganize existing stored data. Users of traditional storage systems keep lots of available free space to avoid batch application failures, wasting valuable space and increasing storage costs. With the RVA it is not necessary to keep lots of free space to avoid out-of-space conditions.

2.2.2 IXFP/SnapShot for VSE/ESA

Based on the belief that the best I/O is no I/O, IXFP/SnapShot for VSE/ESA reduces online system outage by reducing the amount of elapsed time backups and copies need to complete. IXFP/SnapShot for VSE/ESA improves these aspects of batch processing:

- Data backup

Data is backed up during batch processing for many different reasons. Copying data to protect against a hardware, software, or application failure in the computer center is considered an *operational backup*. The backup might be a complete copy of all data, or an incremental copy, that is, a backup of the changes made since the last backup.

Data backups can be taken between processing steps to protect against data loss if a subsequent job or step fails. These backups are called *interim backups*. In some data centers, interim backups are done with tapes.

Using SnapShot to replace the backup and/or copy operations speeds up processing. Tapes are no longer required, and interim backups are done more quickly. Additional interim backup points are now possible because of the instantaneous copy capability and reduced batch processing time. The interim backups are deleted after successful completion of the batch process.

In many cases the operational backups made are also used for disaster recovery. Many of the considerations for disaster recovery are also valid for operational backup. You can minimize the time for disaster backups using SnapShot, by making a SnapShot copy to disk. You can then restart online applications before making a tape backup of the SnapShot copy.

- Data set reorganization

Data set reorganization is very often a time-consuming part of nightly batch processing. The REORG becomes important especially when it is part of the critical path of batch processing. Traditional reorganization procedures copy the affected VSAM key-sequenced data set (KSDS) into a sequential data set on tape or on another DASD. This activity takes a long time when large data sets are copied. SnapShot can dramatically reduce the run time when used in place of IDCAMS REPRO to copy the KSDS into a sequential data set on another DASD.

- Report generation
A large part of batch processing is often dedicated to generating output reports from production data. Often read access only is required by the applications. SnapShot can be used to decrease the contention of multiple read jobs accessing the same data set by replicating critical files and allowing parallel access to multiple copies of the data.
- Production problem resolution
You can use SnapShot to create a copy of the production database when you need to simulate and resolve problem conditions in production. This reduces disruption to the production environment as it is possible to snap complete copies of the production database in a very short time.
- Application processing
SnapShot can be used to speed up any data copy steps during batch processing.

2.3 Application Development

In the area of application development, the RVA and IXFP/SnapShot for VSE/ESA provide dynamic volume configuration and rapid data duplication.

- Dynamic volume configuration
Additional volumes can be easily created if and when required. Using the RVA local operator panel and device address predefinition in the VSE I/O Configuration Program (IOCP), you can dynamically create or remove volumes. You can easily add volumes required to simulate the production environment. Temporary scratch volumes needed as work areas or testing areas can be easily created. Production volumes can be cloned to re-create and resolve a problem.
- Data duplication (including Year 2000)
Several copies of test databases can be easily produced for several testing units to use at the same time, for example, maintenance, user acceptance testing, and enhancements. After a test cycle the test database can be reset by resnapping from the original with SnapShot. Year 2000 testing requires several iterations, to verify code changes with a new date. You can snap your existing production database to create a new test database.

2.4 RVA Data Availability

The design and concept of the RVA are predicated on a very high level of data availability. In this section we discuss the components, functions, and features that guarantee and improve the data availability of the RVA.

2.4.1 Hardware

The RVA hardware is based on an N+1 concept. All functional areas in the machine are duplicated. If one of these areas becomes inoperable because of a hardware problem, other parts of the machine can take over its functions, without losing data availability. In most cases there is no significant performance degradation.

The disk arrays have two spare drives. If a drive fails, the data is immediately reconstructed on one of the spare drives, and the broken drive is fenced. During this process data availability is maintained without performance degradation.

All necessary repair actions due to a hardware failure are performed concurrently with customer operation.

With the RVA, data availability is also maintained during upgrades. Upgrading disk arrays or cache size can be done concurrently with subsystem operation, without impact or performance degradation.

2.4.2 SnapShot

With SnapShot you can make a copy of your online data to use for different tests while the original data is available to the production system. In the same way, you can use a SnapShot copy to back up volumes to tape or other media while online applications continue to have access to the original data.

2.4.3 PPRC

PPRC provides a synchronous copying capability for protection against loss of access to data in the event of an outage at the primary site. Whenever a disaster occurs at the primary site and the data there is no longer available, you can switch to the secondary site. The switch is nearly without impact to or outage of your operating system, and all data is again available with minimal effort.

Chapter 3. VSE/ESA Support for the RVA

In this chapter we cover several utilities and the VSE/ESA Base Programs that support the RVA.

3.1 Prerequisites

The RVA has been supported since VSE/ESA Version 1.4 and RVA microcode level of LIC 03.00.00 or higher. An equivalent microcode level is required for the StorageTek Iceberg 9200.

To use IXFP/SnapShot and PPRC for VSE/ESA (see Chapter 4, "IXFP/SnapShot for VSE/ESA" on page 17 and Chapter 5, "Peer-to-Peer Remote Copy" on page 33) the prerequisites are different from the basic RVA support. The requirements for IXFP/SnapShot for VSE/ESA support are:

- RAMAC Virtual Array Licensed Internal Code (LIC) 04.03.00 or higher. An equivalent microcode level is required for the StorageTek Iceberg 9200.
Note: LIC level 03.02.00 contains support for SnapShot. However, level 04.03.00 introduced nondisruptive code load for the RVA's microcode and is the recommended minimum level.
- VSE/ESA 2.3.0 (5690-VSE) installed with VSE/AF Supervisor with PTF DY44820 or higher.
- SnapShot requires Feature 6001 for existing 9393 systems or RPQ 8S0421 for StorageTek Icebergs.
- If IXFP/SnapShot for VSE/ESA is used in a VM/VSE environment, VM APAR VM61486 is required for minidisk cache (MDC) support.

For PPRC, the requirements are discussed in 5.1, "PPRC and VSE/ESA Software Requirements" on page 34 and 5.2, "PPRC Hardware Requirements" on page 35.

The RVA subsystem provides a set of control and monitoring functions that extend the set of IBM 3990 control functions. Many of these functions can be invoked either from the host with the IXFP/SnapShot for VSE/ESA or directly from the RVA. The Extended Control and Monitoring (ECAM) interface is the protocol for communications between the host CPU and the RVA. The use of the ECAM interface is generally transparent to the user.

These functions require that APAR DY44820 be installed and the phase \$IJBIXFP has been loaded to the SVA via the SET SDL interface. Once the phase has loaded, any of above functions can be invoked through simple operator commands.

If you want to enable SnapShot on a StorageTek 9200, you must submit an RPQ to IBM for each serial number.

Before you use IXFP/SnapShot or PPRC for the RVA, we recommend checking with your local IBM support center to get information about the latest levels of VSE/ESA, microcode, and required APARs.

3.2 Volumes

With VSE/ESA and the RVA, the subsystem volumes can be defined in different emulation modes. This makes the RVA absolutely adaptable to your needs.

The following device type emulations are supported with the RVA:

- 3380 model J, K, and KE (KE is a 3380K compatible device with the same number of cylinders (1770) as a 3380E).
- 3390 models 1, 2, and 3

3.3 Host Connection

Host connectivity options include parallel and/or ESCON attachment. Extended connectivity parallel channel configurations of up to 32 channels are available and supported without bus and tag output connections. The bus and tag outputs are internally terminated, so the RVA must physically be the last in a daisy-chained configuration. ESCON configurations include up to 128 logical links, either as direct links or through an ESCON Director.

The physical channel configuration must match the definitions in the I/O configuration data set (IOCDS). The physical connections on the CPU and the RVA must reflect the statements in the IOCDS. Mistakes can go undetected until later maintenance actions cause unnecessary impact. The channel configuration should be planned such that the impact of a single component failure is minimized. For an IOCDS example, refer to Appendix D, "IOCDS Example" on page 63.

3.3.1 VSE/ESA Input/Output Configuration Program

Support for the stand-alone IOCP is supplied with the hardware system's service processor or processor controller. IOCP describes a system's I/O configuration to the CPU.

Before you install VSE/ESA natively (not under VM/ESA or an LPAR), make sure that you have fully configured your system through IOCP. Starting with VSE/ESA 1.3, the VSE/ESA IOCP is automatically installed during initial installation of VSE/ESA. You can use the IOCP batch program to create a new IOCDS when you change the hardware configuration. You can use the IOCP batch program to define and validate the IOCP macro instructions if you prepare for the installation of a new processor. Use skeleton SKIOPCN (available in VSE/ICCF library 59) as a base for configuration changes.

An IOCDS must be generated for the hardware the first time through the stand-alone IOCP delivered with the processor. For this program you can use prepared IOCP macro instructions that have been generated on another processor. The specified device numbers for VSE/ESA must be within the range 0000 through 0FFF. The devices themselves can be attached to any available link.

For more information about IOCP, refer to the processor's IOCP manual and to the *IOCP User's Guide and ESCON Channel-to-Channel Reference*, GC38-0401.

3.4 ICKDSF

Once the 9393 is installed and the functional devices are defined on the operator panel (see Appendix A, "RVA Functional Device Configuration" on page 41) the only initialization needed for the RVA functional devices is a minimal init, ICKDSF INIT, with the additional parameters needed to define the VOLID and the volume table of contents (VTOC) size and location. The CHECK parameter is not supported, because surface checking is not needed on an RVA. Other ICKDSF functions for surface checking, such as INSTALL or REVALIDATE, also are not supported for the RVA.

The RVA internally uses FBA disk drives with internal data error recovery, so surface checking in this way is inappropriate. If a media surface check is needed, the IBM service representative can do this on the maintenance panel.

ICKDSF Release 16 with applicable PTFs is needed to support the RVA. To run the VSE version of ICKDSF in batch mode, submit a job with an EXEC ICKDSF job control statement.

3.4.1 Volume Minimal Init

In the example in Figure 4 a volume is initialized at minimal level under VSE. A VSE format VTOC is written at cylinder 32, track 0 for a length of 20 tracks. The volume is labeled 338001.

```
// JOB      jobname
// ASSGN    SYS002,151
// EXEC     ICKDSF,SIZE=AUTO
           INIT SYSNAME(SYS002) NOVERIFY -
           VSEVTOC(X'20',X'0',X'14') VOLID(338001)
/*
/ &
```

Figure 4. ICKDSF INIT Volume at the Minimal Level

3.4.2 Partial Disk Minimal Init

In the example in Figure 5, an emulated partial disk is initialized under VSE. A VSE format VTOC is written at cylinder 0, track 1 for a length of one track. The volume is labeled AA3380.

```
// JOB      jobname
// ASSGN    SYS000,353
// EXEC     ICKDSF,SIZE=AUTO
           INIT SYSNAME(SYS000) NVFY VSEVTOC(0,1,1) -
           VOLID(AA3380) MIMIC(EMU(20))
/*
/ &
```

Figure 5. ICKDSF INIT Emulated Partial Disk

For more information about and examples of running ICKDSF under VSE, refer to the *ICKDSF R16 User's Guide*, GC35-0033.

Chapter 4. IXFP/SnapShot for VSE/ESA

IXFP/SnapShot for VSE/ESA is a combination of software and RVA microcode functions. It has three main functions, namely, SnapShot, DDSR, and Report. SnapShot is the data duplication utility that exploits the RVA's virtual disk architecture to achieve instantaneous copy without actually using resources. DDSR releases space occupied by a volume, a cylinder range, and a specified data set. The report functions provide information about the space utilization and subsystem utilization summary of the RVA.

A new attention routine (\$IJBIXFP) has been provided in VSE. You invoke IXFP/SnapShot for VSE/ESA functions through the attention routine in three basic ways:

1. From a console

You enter the IXFP/SnapShot for VSE/ESA functions on the command line of the VSE operator console or through the interactive computing and control facility (ICCF) console operator interface.

Note: Make sure that you are authorized to enter operator commands when using the ICCF console operator interface.

Figure 6 illustrates invoking IXFP REPORT functions directly from the operator console.

```
SYSTEM : VSE/ESA          VSE/ESA 2.3          USER :  
                                TIME :  
  
AR 0015 1140I  READY  
  
-----  
==> IXFP REPORT<enter>
```

Figure 6. Sample Operator Console Screen to Invoke IXFP REPORT Functions

2. From a batch job

You can code the function you want to invoke in the PARM field of the VSE-provided DTRIATTN module and submit the batch job for execution. Figure 7 illustrates the report function (IXFP REPORT) being invoked by a batch job using DTRIATTN.

```
// JOB      jobname
// log
// EXEC     DTRIATTN,PARM=' IXFP REPORT'
/ &
```

Figure 7. Sample Batch Job to Invoke IXFP Report Function

3. From a REXX CLIST

You can code the IXFP function in the SENDCMD of REXX. Use of a REXX CLIST allows use of logic for automated procedures. Figure 8 shows the statements required to catalog the REXX procedure. Figure 9 on page 19 illustrates invoking the report function (IXFP REPORT) from a REXX CLIST in a batch job. The second SENDCMD in the job is a dummy. It is coded to illustrate the possibility of coding other IXFP/SnapShot for VSE/ESA or VSE commands, thus providing flexibility for creating automated procedures.

```
* $$ JOB JNM=IXFPREXC,CLASS=0,DISP=D
// JOB IXFPREXC
// EXEC LIBR
ACC S=PRD2.CONFIG
CAT IXFPREXX.PROC R=Y
/* ----- */
/*      REXX/VSE procedure to issue console commands      */
/* ----- */
trace off
arg parm_string
parse var parm_string command1 '#' command2
rc = SENDCMD( command1 )      /* Submit first command      */
if rc = 0
then do
  call sleep 5                /* Wait before submitting next command */
  rc = SENDCMD( command2 )    /* Submit second command     */
end
exit rc
/+
/*
/ &
* $$ EOJ
```

Figure 8. Cataloging a REXX CLIST Procedure to Invoke an IXFP Function

```
* $$ JOB JNM=IXFPREXX,CLASS=0,DISP=D
// JOB IXFPREXX
// LIBDEF *,SEARCH=(PRD2.CONFIG,PRD1.BASE)
// EXEC REXX=IXFPREXX,PARM='IXFP REPORT#<your-console-cmd-2>'
/&
* $$ E0J
```

Figure 9. Using a REXX CLIST As a Batch Job Step to Invoke an IXFP Function

Note: More information about the REXX/VSE console automation capability can be found in Chapter 14 of the *REXX/VSE V6 R1.2 Reference Manual*, SC33-6642-01.

4.1 IXFP SNAP

SNAP identifies this command as a SNAP function. Figure 12 shows the syntax of the IXFP SNAP command.

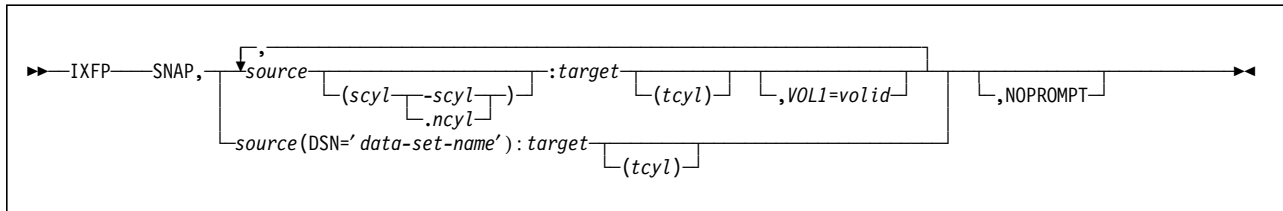

Figure 12. Syntax of IXFP SNAP Command

Note: SnapShot commands can be set up to be invoked by end users as well as by database administrators and system programmers.

There are three ways to do a SnapShot. You can take a copy of:

- A full volume
- A range of cylinders
- A non-VSAM file

4.1.1 A Full Volume

You copy a full volume by identifying the device address (cuu) or VOLID label of the source and target in the IXFP SNAP command. Intermixing of the device address and VOLID label to specify the source and target in the IXFP command is allowed. Use the VOL1= parameter to specify the volume label that the target will assume after the copy has completed. If the VOL1= parameter is omitted, the source and target volumes will have the same VOLID label when the copy is completed.

To illustrate, we use two volumes: PATEV1 and PATEV2. The device addresses of these volumes are 80E and 80F, respectively. To copy the first volume onto the second volume, issue any of the following commands:

- IXFP SNAP,80E:80F,NOPROMPT
- IXFP SNAP,PATEV1:PATEV2,NOPROMPT
- IXFP SNAP,PATEV1:80F,NOPROMPT

In this case the source 80E and target 80F will have the same VOLID label (PATEV1) after the snap completes. A VOL1= parameter can be used to give the target a specific VOLID label after the snap of the source volume. Continuing with the example, to give the target volume a VOLID label of PATEV3, we include a VOL1= parameter indicating VOLID label PATEV3. Use one of the following commands;

- IXFP SNAP,80E:80F,VOL1=PATEV3,NOPROMPT
- IXFP SNAP,PATEV1:80F,VOL1=PATEV3,NOPROMPT

The NOPROMPT parameter is included to prevent decision-type messages from being issued. Otherwise, decision-type messages are issued for the operator to verify and confirm (see Figure 13 on page 22).

```

AR 0015 1I40I  READY

ixfp snap,80e:80f,vol1=patev3

AR+0015 IXFP23D SNAP FROM CUU=80E CYL='0000' TO CUU=80F CYL='0000' NCYL='0DOB
- REPLY 'YES' TO PROCEED
15 yes
AR 0015 IXFP22I SNAP TO  CUU= 80F STARTED AT 18:46:51  11/16/1998
AR 0015 IXFP20I SNAP FUNCTION COMPLETED  AT 18:46:51  11/16/1998
AR 0015 1I40I  READY

```

Figure 13. Decision-Type Message Issued to Confirm SNAP

VSE/VSAM

VSE/VSAM support is not currently included in IXFP/SnapShot for VSE/ESA. However, you can still take advantage of IXFP/SnapShot for VSE/ESA with VSE/VSAM data sets. With volume snap, VSAM data sets can be indirectly copied when the VSAM catalog, space, and cluster are in the same volume. In VSE, you can reference the two USER CATALOGs individually through the use of the ASSGN JCL statement; however, the VSAM share option restrictions still apply. The ideal scenario is to assign the target volume into another LPAR so as not to encounter the restrictions and further processing or copy to tape using IDCAMS REPRO. If the purpose of the volume snap is for backup using FASTCOPY or DDR (VM), the VSAM share option restrictions will not be encountered.

See Appendix C, "VSE/VSAM Considerations" on page 59.

Notes:

If the source is identified by its VOLID, it must be either the only volume with that VOLID or the only VOLUME with that VOLID that is up (DVCUP). Otherwise an error message will be issued.

The target device must be down (DVCDN) before you initiate the volume snap.

If the target device is identified by its VOLID, it must be either the only volume with that VOLID or the only volume with that VOLID which is down (DVCDN). Otherwise an error message will be issued.

Only when doing full volume snaps can you use the VOL1 parameter.

Volume copying is done unconditionally within the specified or assumed boundaries. VSE does not perform any VTOC checking on the specified target device and thus does not provide any warning messages regarding overlapping extents or secured or unexpired files.

When you duplicate a volume, both the source and the target must be within the same RVA. (If you are using test partitions, the source and the target must also be in the same partition.)

4.1.2 A Range of Cylinders

You copy a range of cylinders by identifying the device address or VOL1 label of the source and target in the IXFP SNAP command. In addition, the decimal start cylinder (scyl) and end cylinder (-scyl) or number of cylinders (,ncyl) are specified in parentheses and appended to the source specification. Optionally, the target start cylinder (tcyl) can be included to specify where copying is to start on the target device.

To illustrate, we use two volumes: PATEV1 and PATEV2. The device addresses of these volumes are 80E and 80F, respectively. To copy cylinders 0 through 999 in the first volume onto the second volume, issue one of the following commands:

- IXFP SNAP,80E(0000-0999):80F,NOPROMPT
- IXFP SNAP,80E(0000,1000):80F,NOPROMPT
- IXFP SNAP,PATEV1(0000-0999):PATEV2,NOPROMPT
- IXFP SNAP,PATEV1(0000,1000):PATEV2,NOPROMPT

You specify the target start-cylinder (tcyl) to relocate the range of cylinders on the target volume. Indicate target start-cylinder 1000 to relocate the range of cylinders on the target volume. You can issue one of the following modified commands:

- IXFP SNAP,80E(0000-0999):80F(1000),NOPROMPT
- IXFP SNAP,80E(0000,1000):80F(1000),NOPROMPT
- IXFP SNAP,PATEV1(0000-0999):PATEV2(1000),NOPROMPT
- IXFP SNAP,PATEV1(0000,1000):PATEV2(1000),NOPROMPT

You may or may not include the NOPROMPT parameter to prevent or allow decision-type messages (see Figure 13 on page 22).

Notes:

If the source is identified by its VOLID, it must be either the only volume with that VOLID or the only VOLUME with that VOLID which is up (DVCUP). Otherwise an error message will be issued.

The target device must be down (DVCDN) before you initiate the volume snap, except when the source and the target device are the same device.

If the target device is identified by its VOLID, it must be either the only volume with that VOLID or the only volume with that VOLID which is down (DVCDN). Otherwise an error message will be issued.

The highest (end) cylinder number must not exceed 32767 or the maximum number of cylinders of the devices. The start cylinder number must not be greater than the end cylinder number.

You cannot use the VOL1 parameter when copying cylinder ranges.

Cylinder range copying is done unconditionally within the specified or assumed boundaries. VSE does not perform any VTOC checking on the specified target device and thus does not provide any warning messages regarding overlapping extents or secured or unexpired files.

The source and the target device must be of the same type and must be within the same RVA subsystem. (If you are using test partitions, the source and the target must also be in the same partition.)

4.1.3 A Non-VSAM File

You copy a file by indicating the data set name on the source device, using the DSN= (data set name) parameter, in addition to identifying the source and target device address or VOLID labels. The file specified must be non-VSAM. Optionally, the target start cylinder (tcyl) can be included to specify where copying is to start on the target device if relocation is required.

To illustrate, we use two volumes: PATEV1 and PATEV2. The device addresses of these volumes are 80E and 80F, respectively. To copy file 'test.data.1' in volume 80E onto volume 80F, issue one of the following commands:

- IXFP SNAP,80E(DSN=' test.data.1'):80F,NOPROMPT
- IXFP SNAP,PATEV1(DSN=' test.data.1'):80F,NOPROMPT

If you want to copy file 'test.data.1' to cylinder 1000 on volume 80F, you must specify the target start cylinder (tcyl). Issue one of the following modified commands:

- IXFP SNAP,80E(DSN=' test.data.1'):80F(1000),NOPROMPT
- IXFP SNAP,80E(DSN=' test.data.1'): PATEV2(1000),NOPROMPT

Notes:

If source is identified by its VOLID, it must be either the only volume with that VOLID or the only VOLUME with that VOLID that is up (DVCUP). Otherwise an error message will be issued.

The target device must be down (DVCDN) before you initiate the volume snap, except when the source and the target are the same device.

If the target device is identified by its VOLID, it must be either the only volume with that VOLID or the only volume with that VOLID that is down (DVCDN). Otherwise an error message will be issued.

The highest (end) cylinder number must not exceed 32767 or the maximum number of cylinders of the devices. The start cylinder number must not be greater than the end cylinder number.

You cannot use the VOL1 parameter when copying a non-VSAM file.

When you snap files, VSE performs VTOC checking on the specified target device and provides warning messages regarding overlapping extents or secured or unexpired files.

The source and the target device must be of the same type and must be within the same RVA subsystem. (If you are using test partitions, the source and the target must also be in the same partition.)

See B.1, "SNAP Command" on page 43 for additional illustrations.

4.2 IXFP DDSR

DDSR identifies this command as a DDSR function. DDSR causes the release of the physical storage space associated with:

- Expired files
- A total volume
- A range of cylinders
- A specified file

This function ensures that all space releases done on the VSE system (normally through deletes) result in space releases in the RVA subsystem. Figure 14 shows the syntax of the IXFP DDSR command.

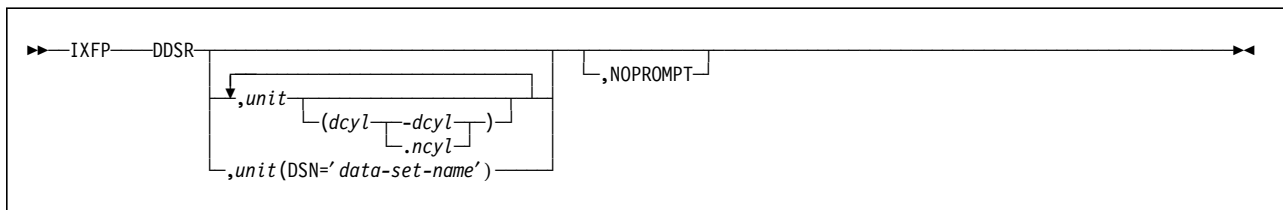

Figure 14. Syntax of IXFP DDSR Command

4.2.1 Expired Files

DDSR, when specified without any additional parameters, deletes the VTOC entries and all physical space for all expired nonsecured files residing on VSE managed RVA devices. These extents are freed up and become part of free space.

To illustrate, we use two volumes: PATEV1 and PATEV3. The device addresses of these volumes are 80E and 80F, respectively. To delete all VSE-recognized expired files, issue the following command:

```
IXFP DDSR,NOPROMPT
```

The NOPROMPT parameter is included to prevent decision-type messages from being issued. Otherwise, decision-type messages are issued for the operator to verify and confirm (see Figure 15).

```
AR 0015 1I40I  READY
IXFP DDSR
AR+0015 IXFP26D 'TEST.DATA.1' HAS EXPIRED ON CUU=80E - REPLY 'YES' FOR DELETION
15 YES
AR+0015 IXFP26D 'TEST.DATA.1' HAS EXPIRED ON CUU=80F - REPLY 'YES' FOR DELETION
15 YES
AR 0015 1I40I  READY
```

Figure 15. Decision-Type Message Issued to Confirm DDSR Expired Files

Notes:

When you do DDSR for expired files, VSE performs checking on the online (up) units.

DDSR checks only those RVA devices managed by the VSE system.

DDSR considers only the files created by VSE.

4.2.2 A Total Volume

It is possible to delete and release space for an entire volume when you include the device address or VOLID label with no other operands.

To illustrate, we use volume PATEV3 with device address 80F. To delete all data including the VTOC and VOLID label of PATEV3, issue the following command:

```
IXFP DDSR,PATEV3
```

The NOPROMPT parameter is included to prevent decision-type messages from being issued. Otherwise, decision-type messages are issued for the operator to verify and confirm (see Figure 16).

```
AR 0015 1I40I  READY
IXFP DDSR,PATEV3
AR+0015 IXFP29D DDSR FOR  CUU=80F (WHOLE VOLUME) - REPLY 'YES' FOR DELETION
15 YES
AR 0015 1I40I  READY
```

Figure 16. Decision-Type Message Issued to Confirm DDSR Volume

Notes:

The device should belong to the RVA subsystem managed by the VSE system.

The device should be in the offline (DVCDN) condition.

The device should be reinitialized before you use it as a regular volume again. However, if you are going to use it as a target for a volume snap, you can leave it as is.

4.2.3 A Range of Cylinders

This command is similar to the DDSR volume command, except that additional specifications are added to signify the decimal start cylinder and end cylinder (dcyl-dcyl) or the decimal start cylinder and the number of cylinders (dcyl,ncyl) to delete.

To illustrate, we use volume PATEV3 with device address 80F. To delete all data from cylinders 0 through cylinder 999, issue the following command:

```
IXFP DDSR,PATEV3(0000-0999),NOPROMPT
```

The NOPROMPT parameter is included to prevent decision-type messages from being issued. Otherwise, decision-type messages are issued for the operator to verify and confirm (similar to Figure 16).

Notes:

The device should belong to the RVA subsystem managed by the VSE system.

The device should be in the offline (DVCDN) condition.

The highest (end) cylinder number must not exceed 32767 or the maximum number of cylinders of the devices. The start cylinder number must not be greater than the end cylinder number.

4.2.4 A Specified File

This command is similar to doing DDSR for a specific range of cylinders. The difference is that a DSN= specification is coded in place of the decimal start cylinder and decimal end cylinder (dcyl-dcyl).

To illustrate, we use volume PATEV3 with device address 80F. To delete file 'test.data.3' on volume PATEV3, issue the following command:

```
IXFP DDSR,PATEV3(DSN=' test.data.3' ),NOPROMPT
```

The NOPROMPT parameter is included to prevent decision-type messages from being issued. Otherwise, decision-type messages are issued for the operator to verify and confirm (similar to Figure 16 on page 26).

Notes:

The device should belong to the RVA subsystem managed by the VSE system.

The device should be in the online (DVCUP) condition. Otherwise the command is rejected, and an error message is displayed.

The file must be non-VSAM.

The file will be deleted unconditionally and the space returned to the RVA freespace.

When you process multivolume files, repeat DDSR for all volumes containing the file extents.

See B.2, "DDSR Command" on page 49 for additional illustrations.

4.3 IXFP REPORT

The IXFP REPORT command provides information about the space utilization of a single RVA device or a range of RVA devices. It also provides information about the space utilization of all devices (that were added during IPL) of an RVA subsystem as well as important subsystem utilization summary information.

Figure 17 on page 28 shows the syntax of the IXFP REPORT command.

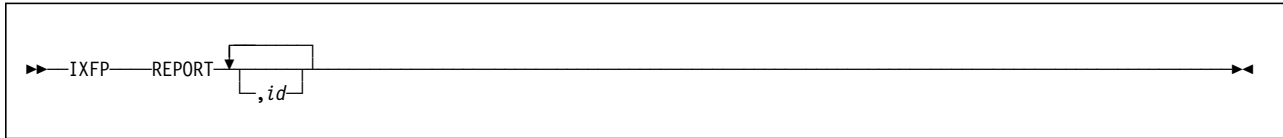

Figure 17. Syntax of IXFP REPORT Command

When the command is issued without the *id* parameter, all information about every RVA subsystem, including all devices known to the VSE system, is displayed.

If you need information about a specific device, a specific range of devices, or a specific RVA subsystem, include the *id* parameter to limit the scope of the report output.

To illustrate, we use two volumes: PATEV1 and PATEV2. The device addresses of these volumes are 80E and 80F, respectively. To display space utilization for one of the devices, issue one of the following commands:

- IXFP REPORT,80E
- IXFP REPORT,80F

It is also possible to display the space utilization of the two devices in one command by including the addresses of the two devices. Issue the following command:

```
IXFP REPORT,80E,80F
```

To get all space information for the entire VSE system, issue the command without any additional parameter:

```
IXFP REPORT
```

Notes:

The device must belong to the RVA subsystem managed by the VSE system.

If used under VM, REPORT only works for full-pack minidisks or dedicated devices.

NOPROMPT is not a valid parameter for IXFP REPORT.

Issuing IXFP REPORT or IXFP REPORT,80 yields the same result because we are only using one RVA subsystem and there is only one device address range (80).

Figure 18 on page 29 shows a sample IXFP REPORT output.

```

ixfp report
AR 0015 SUBSYSTEM 1321117
AR 0015 *** DEVICE    DETAIL REPORT ***
AR 0015    <---FUNC. CAPACITY (MB)---> <---CAPACITY (%)--->  PHYS.  COMP.
AR 0015 CUU  DEF  ALLOC STORED UNUSED  ALLOC  STORED UNUSED USED(MB)  RATIO
AR 0015 80E 2838.0 N/A  369.2 2468.7  N/A   13.01 86.99  213.6  1.72
AR 0015 80F 2838.0 N/A    0.8 2837.1  N/A    0.03 99.97   0.0   9.65
AR 0015
AR 0015 *** DEVICE    SUMMARY REPORT
AR 0015 CAPACITY      <-----TOTAL-----> <-----TOTALS %------>  COMP.
AR 0015  DEFINED                5676.032 MB 100.00                                RATIO
AR 0015  STORED                  370.129 MB          6.52
AR 0015  PHYS.USED                213.688 MB          3.76          1.73
AR 0015  UNUSED                  5305.903 MB          93.48
AR 0015
AR 0015 *** SUBSYSTEM SUMMARY REPORT ***
AR 0015 SYSTEM  DEFINED-CAPACITY  DISK-ARRAY-CAP  FREE-DISK-ARRAY-CAP
AR 0015  PROD      726532.208 MB  117880.209 MB  57752.311 MB
AR 0015
AR 0015 NET-CAPACITY-LOAD(%)  COLL.-FREE-SPACE(%)  UNCOLL-FREE-SPACE(%)
AR 0015 TEST  PROD  OVERALL  TEST  PROD  OVERALL  TEST  PROD  OVERALL
AR 0015 0.00 51.01 51.01  0.00 47.55 47.55  0.00 1.44 1.44
AR 0015 1I40I  READY

```

Figure 18. Sample Output of IXFP REPORT Command

See B.3, "Report Command" on page 52 for further illustrations.

In the sections that follow we define the field names and column headings of the reports that IXFP REPORT provides.

4.3.1 Device Detail Report

- cuu** This is the device ID of the device to which the data applies.
- <---FUNC. CAPACITY (MB)--->** This heading covers the fields that provide information about the functional capacity in megabytes for a certain device. Functional capacity in this sense is the capacity that would exist on traditional count key data (CKD) or extended count key data (ECKD) devices.
 - DEF** This field contains the functional capacity in megabytes defined to the subsystem for this specific device.
 - ALLOC** This field is the functional space allocated by the VTOC. This data is not currently available for VSE/ESA.
 - STORED** This field contains the functional capacity in megabytes stored (occupying disk array storage) for the device or subsystem.
 - UNUSED** This field contains the part of the functional capacity defined for the device or subsystem that is not mapped and thus unused (that is, not occupying disk array storage).
- <--- CAPACITY (%)--->** This heading covers the fields that provide information about the percentage of the defined functional capacity assigned to the individual groups.
 - ALLOC** This field is the percentage of functional space allocated by the VTOC. This data is not currently available for VSE/ESA.

STORED This field contains the percentage of the defined functional capacity that contains stored data (occupying disk array storage) for the device or subsystem.

UNUSED This field contains the percentage of the defined functional capacity for the device or subsystem that does not yet contain data and is thus unused (that is, not occupying disk array storage).

PHYS. USED(MB) This heading covers the field containing the real capacity in megabytes, that occupies disk array storage, as opposed to the functional capacity. The difference between the stored and the physical used capacity is the savings due to compression and compaction performed by the RVA subsystem for this device.

COMP. RATIO This heading covers the field containing the real compaction ratio, which is the quotient of functional capacity stored/physical used capacity.

4.3.2 Device Summary Report

CAPACITY This column covers the capacity groups that are being differentiated.

<-----TOTAL-----> This column covers the total capacity in megabytes that has been allocated to the appropriate group in that line. The capacity is the sum of all the devices that were selected for the report.

<-----TOTALS %-----> This column shows the percentage of capacity that the group in the appropriate line is occupying, always compared to the 100% defined functional capacity in the first row. The percentage is based on all the devices that were selected for the report.

COMP. RATIO This column shows the real compaction ratio, which is the quotient of the total functional capacity stored/total physical used capacity and is a measure of the overall compaction for the devices selected for the report.

4.3.3 Subsystem Summary Report

SYSTEM This column identifies the system to which the capacity outlined in the appropriate line applies. If a test system has not been configured, only the PROD system information is provided.

DEFINED-CAPACITY This column contains the functional capacity in megabytes for the whole subsystem as it has been configured.

DISK-ARRAY-CAP This column contains the total disk array capacity in megabytes for the whole subsystem that has been installed.

FREE-DISK-ARRAY-CAP This column contains the current free disk array capacity in megabytes that is still available for allocation by the RVA subsystem.

NET-CAPACITY-LOAD(%) This column contains the percentage of the disk array capacity that is currently being occupied by the TEST, PROD, or both (OVERALL) systems. This is probably the most important value and has been placed at the beginning of the very last report line to make it easy to find.

COLL.-FREE-SPACE(%) This column contains the percentage of the array cylinders in the subsystem that are free array cylinders (that is, the total space that can be written to).

UNCOLL-FREESPACE(%) This column contains the percentage of the array capacity originally occupied when a functional track has been rewritten to a new location in the disk array.

Chapter 5. Peer-to-Peer Remote Copy

In this chapter we describe the VSE/ESA support for the RVA and the PPRC.

As part of the continuing effort to meet customer requirements for 24-hour 7-day availability, the RVA Model T82 provides remote copy for disaster and critical volume protection. PPRC is supported by OS/390, VSE/ESA, and VM/ESA. PPRC complements the existing availability functions of the RVA, such as the dual power systems, nonvolatile storage (NVS), and nondisruptive installation and repair.

PPRC standardizes and streamlines today's disaster recovery data backup capabilities by providing data-type independent remote copy. The implementation provides a choice based on business requirements such as performance needs, data synchrony criteria, system resource considerations, operational control requirements, and recovery distance requirements.

PPRC provides an RVA synchronous data copying capability for protection against loss of access to data in the event of an outage at the primary site. Updates are sent from the primary RVA directly to the recovery RVA in a cache to cache communication through dedicated ESCON links between the two RVAs. The RVA can be located up to 43 km (26.7 mi) from the host. The primary and secondary volumes must be of the same track geometry.

Figure 19 shows two host systems with an RVA attached to each. The two RVAs are attached on at least one ESCON path. ESCON Directors can be used to extend the distance between the two hosts up to 43 km. The second host is optional if PPRC is being used to migrate data from one RVA to a second within the same data center.

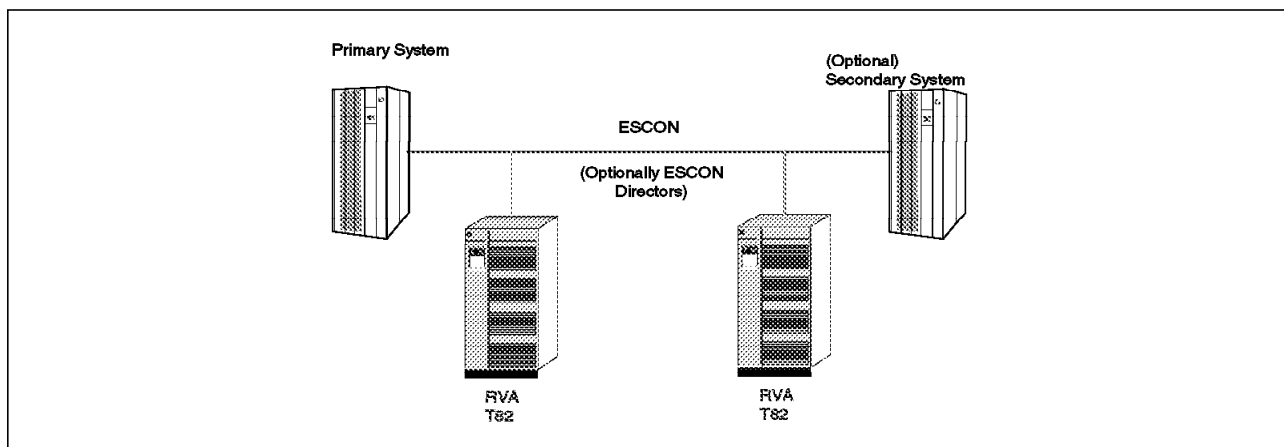

Figure 19. Peer-to-Peer Remote Copy

Both RVAs can treat writes as DASD fast write (DFW) operations. The primary RVA write is handled normally, and it is processed as a cache hit whenever possible; the write to the secondary subsystem is always treated as a write hit. This capability, and the inherent performance capabilities of the RVA, help to mitigate the unavoidable performance impacts of writing the data to both RVAs before signaling the operation as complete to the primary host application.

Figure 20 on page 34 shows the data flow between the host and the two RVAs. This would be the sequence of a write operation to the primary RVA:

1. The host application issues a write request to a file, and the VSE/ESA supervisor converts the request to a start subchannel request to the RVA. The RVA receives the request, compresses the data as it comes across the ESCON host adapter, and stores the data in both its cache and NVS.
2. Channel end is returned to the host, indicating that the channel and device are available for additional I/O operations.
3. At the same time, the updated array data, in its compressed and compacted form, is transferred across the ESCON channel to the secondary RVA. Because the primary RVA looks like a host to the secondary, the secondary RVA stores the data in its cache and NVS and returns channel end to the primary.
4. When the primary RVA receives the channel end from the secondary, it presents device end for the write request.

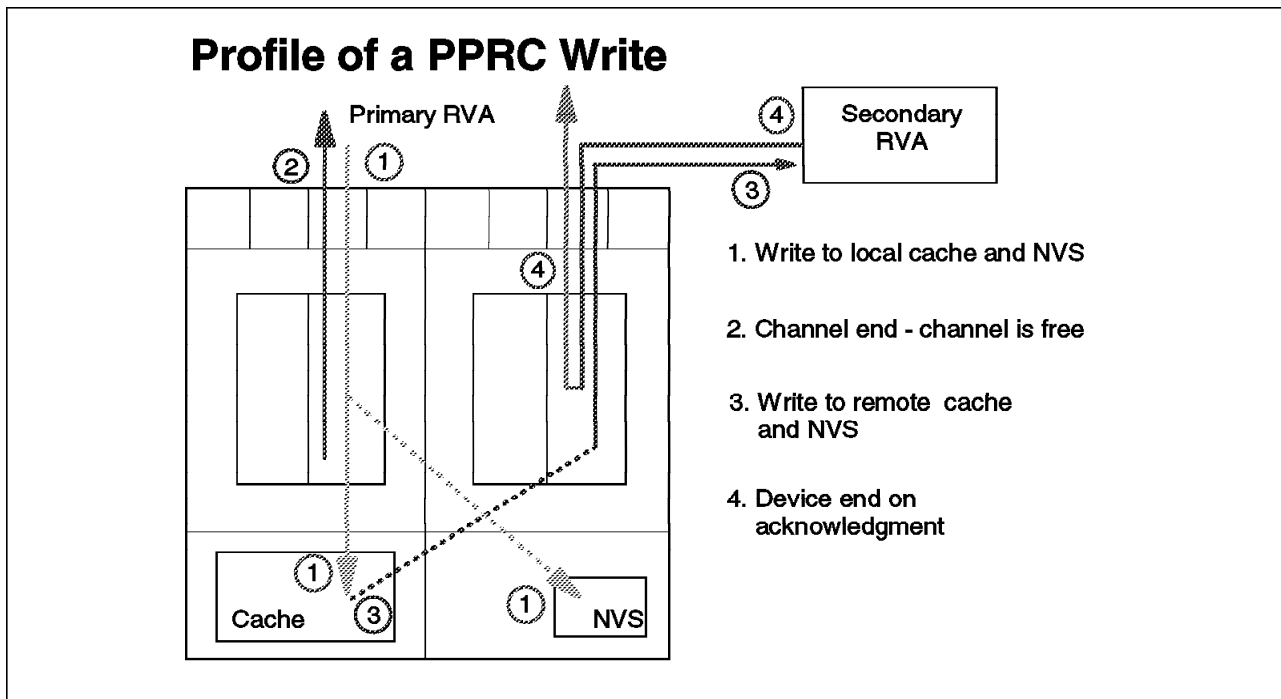

Figure 20. PPRC Data Flow

5.1 PPRC and VSE/ESA Software Requirements

As always, when preparing for new functions, be sure to check with the IBM Software Support Center before implementing PPRC. Order, install, and test PTFs, using the customer's normal change management processes. **Check Information APAR II08303 for the latest list of APARs and PTFs required to use the PPRC functions.**

VSE/ESA Version 2 Release 3.1 is the minimum release level for PPRC support. APAR fixes DY44407 and DY44616 are needed to support PPRC.

ICKDSF Release 16 "refreshed" by APAR PQ20390 contains the support for PPRC on the RVA.

5.2 PPRC Hardware Requirements

The hardware requirements for both the primary and secondary RVAs to support PPRC are:

- RVA Model T82
- Feature code 7001
- PPRC-enabling LIC
(LIC level T04.05.xx is the minimum level)
- Remote Service capability

Note: We recommend that 4 GB of cache be installed on the RVAs to maximize performance. We also recommend four ESCON links between the two subsystems.

5.3 Invoking peer-to-peer remote copy

You initiate PPRC by using the ICKDSF PPRCOPY command with the options shown in Table 1.

| PPRCOPY Command Option | Function | Primary Site | Secondary Site |
|------------------------|---|--------------|----------------|
| ESTPATH | Establishes ESCON paths between the RVA of an application (primary) site and a recovery (secondary) site. | Yes | No |
| DELPATH | Deletes all established ESCON paths between primary and secondary site RVA. | Yes | No |
| ESTPAIR | Establishes a remote copy device pair. | Yes | No |
| DELPAIR | Removes primary and secondary volumes from PPRC and returns the devices to a simplex state. | Yes | No |
| QUERY | Queries the status of a PPRC volume pair and the paths associated with the RVA for the addressed device. | Yes | Yes |
| RECOVER | Allows the recovery site system to regain control of a DASD volume on its RVA. | No | Yes |
| SUSPEND | Suspends PPRC operation between a primary and secondary pair. | Yes | Yes |

Note: The ICKDSF PPRCOPY commands for the primary device are issued at the primary (application) site. Commands for the secondary device are issued at the secondary (recovery) site.

Note: The PPRCOPY QUERY VOLUME command should be used to display the subsystem identifier (SSID), serial number, and channel connection (logical) address (CCA) of a device. (The CONTROL CONFIGURE (DISPLAY) command does not work with the RVA. It works only with the 3990/9390 storage controls.)

For an example of using the PPRCOPY command, see 5.5, “Examples of PPRCOPY Commands” on page 36. For a more detailed description of the PPRCOPY command, see *Device Support Facilities User’s Guide and Reference, Release 16 Refresh with Peer-to-Peer Remote Copy*, GC35-0033.

5.4 SnapShot Considerations

The RVA provides the unique ability to combine SnapShot functions with PPRC functions. There are some considerations regarding the interaction of SnapShot with volumes that are part of a PPRC pair.

You cannot use SnapShot to copy data onto any volume that is part of a PPRC pair. SnapShot requires that addresses be available on the same RVA subsystem where the source of the copy resides. If SnapShot is going to be used on an RVA subsystem that also has PPRC pairs, there must be some logical volumes on that subsystem that are not part of a PPRC pair. Therefore, all 256 logical volumes in an RVA subsystem cannot be part of a PPRC pair and also use SnapShot on that same RVA.

5.4.1 Primary Devices of a PPRC Pair

You cannot use SnapShot to copy to a target that is the primary of a PPRC pair, regardless of whether the primary is in an active or suspended state. The primary volume can be the source for a SnapShot copy. Making a copy does not require modifying the PPRC state of the primary volume.

When dynamically allocating space for a SnapShot target, SnapShot uses all volumes available to it on a space available basis. It does not check PPRC status. SnapShot should not be provided a volume list that includes volumes that are part of a PPRC pair. The SnapShot copy will fail if any part of a data set is allocated to a volume that is part of a PPRC pair.

5.4.2 Secondary Devices of a PPRC Pair

If SnapShot will be used on a secondary RVA subsystem, there must be space available on the subsystem in addition to that used by PPRC pairs. You cannot have all 256 logical volumes as part of PPRC pairs.

Remember that you cannot issue reads or writes to a secondary volume of a PPRC pair. However, by using a procedure like the following, you can make SnapShot copies of data from the secondary device—and return it to active status very quickly:

1. SUSPEND the pair.
2. RECOVER the secondary—returning it to simplex status.
3. Make the SnapShot copy.
4. ESTPAIR RESYNC the secondary to copy only the changes from the primary.

5.5 Examples of PPRCOPY Commands

In this section we demonstrate the use of the ICKDSF PPRCOPY commands to initiate a PPRC pair.

In the examples that follow, two devices are used. At the primary site, the RVA's SSID is x'0057', the serial number of the storage control is 7390007, and the CCA is x'D48'. (The serial number actually has two parts—the first two digits indicate the plant of manufacture, and the last five digits are the machine serial number.) At the secondary site, the RVA's SSID is x'053F', the serial number of the storage control is 7390014, and the CCA is x'D8C'. (See 5.6, "Physical Connections to the RVA" on page 38 for the relationship between the logical control unit number and the CCA.)

In the examples that follow, the short form of some of the parameters is used. The long form of these parameters is:

- NoVeriFY
- PRIMary
- SECondary
- UNITaddress

5.5.1 Setting Up PPRC Paths and Pairs

The sequence of tasks for setting up PPRC at the primary site is:

1. Obtain the SSID, serial number, and CCA for both the primary and secondary sites' storage controls. The PPRCOPY QUERY command can be used to obtain this information. Issue the following commands at the respective host processors:

```
PPRCOPY QUERY UNIT(D48)
PPRCOPY QUERY UNIT(D8C)
```

2. Obtain the physical RVA system adapter IDs (SAIDs). There are 8 for an 8-channel machine and 16 for a 16-channel machine.
3. Use the PPRCOPY QUERY command to check the status of the primary and secondary devices to determine whether they are in simplex mode and the paths are already set. Issue the following commands at the respective host processors:

```
PPRCOPY QUERY UNIT(D48) PATHS
PPRCOPY QUERY UNIT(D8C) PATHS
```

4. Establish the path, using ESTPATH:

```
PPRCOPY ESTPATH UNIT(D48)
  PRIM(X'0057',7390007) SEC(X'053F',7390014)
  LINK(X'004D600', X'00510003')
```

Warning: The ESTPATH command acts as a *replace* function. The paths specified in it establish the link between the storage controls at the primary and secondary sites. They replace any PPRC paths previously established between the pair of storage controls.

Note: This example uses two links. Although a single link is possible, it is advisable to define more than one LINK between the primary and secondary for availability reasons.

5. Establish a pair, using ESTPAIR:

```
PPRCOPY ESTPAIR UNIT(D48) MODE(COPY)
  PRIM(X'0057',7390007,X'07') SEC(X'053F',7390014,X'0F')
```

Note: The PACE parameter of the ESTPAIR command is ignored.

6. Monitor the progress, using QUERY:

```
PPRCOPY QUERY UNIT(D48)
```

5.5.2 Recovering from a Primary Site Failure

Assume that a primary site failure occurred after step 6 above, PPRC has been activated, and the pair has been established. This example shows the recovery at the secondary site:

1. Suspend the secondary site device, using SUSPEND:

```
PPRCOPY SUSPEND(SEC) UNIT(D48)
PRIM(X'0057',7390007,X'07') SEC(X'053F',7390014,X'0F')
```

2. Check on the secondary device, using QUERY at the recovery site:

```
PPRCOPY QUERY UNIT(D8C)
```

3. Issue the RECOVER command at the recovery site:

```
PPRCOPY RECOVER UNIT(D8C) NVFY
PRIM(X'0057',7390007,X'07') SEC(X'053F',7390014,X'0F')
```

The secondary device is now available for use at the recovery site.

5.5.3 Recovering from a Secondary Site Failure

Assume that a secondary site failure occurred after step 6 of 5.5.1, "Setting Up PPRC Paths and Pairs" on page 37, PPRC has been activated, and the ESTPAIR was completed. This example shows the recovery at the primary site:

1. Suspend the primary site device, using SUSPEND:

```
PPRCOPY SUSPEND(PRIM) UNIT(D48)
PRIM(X'0057',7390007,X'07') SEC(X'053F',7390014,X'0F')
```

2. Repair the problem with the secondary device.

3. Reestablish the PPRC pair. Update the volume by copying only the changed track(s), using ESTPAIR:

```
PPRCOPY ESTPAIR UNIT(D48) MODE(RESYNC)
PRIM(X'0057',7390007,X'07') SEC(X'053F',7390014,X'0F')
```

5.5.4 Deleting PPRC Pairs and Paths

Now, assume that you want to terminate the pair—if no failure occurred after step 6 of 5.5.1, "Setting Up PPRC Paths and Pairs" on page 37. (This example could be used if you were using PPRC to migrate data from the primary site to the secondary site.)

1. Issue DELPAIR:

```
PPRCOPY DELPAIR UNIT(D48)
PRIM(X'0057',7390007,X'07') SEC(X'053F',7390014,X'0F')
```

This command must complete before the paths can be deleted.

2. Issue DELPATH:

```
PPRCOPY DELPATH UNIT(D48) PRIM(X'0057',7390007) SEC(X'053F',7390014)
```

Note: Execute the PPRCOPY DELPATH command if there are no actively paired devices between the primary and secondary site RVAs. There is no single ICKDSF command that can identify all active PPRC devices. For each device attached to an RVA for which you want to suspend a path, you must use the PPRCOPY QUERY command.

5.6 Physical Connections to the RVA

Neither the logical control unit (LCU) nor the CCA is intuitively obvious.

5.6.1 Determining the Logical Control Unit Number for RVA

You can calculate the LCU number by using the CUADD value used in the IOCP configuration for each LCU. Each of the four CUADDs contains 64 devices.

If the device numbers on the RVA have been generated as a contiguous group of 256 addresses, the LCU can be calculated from the last two digits of the device number. For example, for devices with an address between A40 and A7F, the corresponding LCU is LCU1. Table 2 shows the relationship between the device numbers and LCUs.

5.6.2 Determining the Channel Connection Address

The CCA on an RVA is relative to the LCU and is always between 00 and 3F. If the device numbers have been generated as a contiguous group of 256 addresses, the CCA can be calculated from the last two digits of the device number as shown in Table 2. For example, for device numbers AC0 through AFF, subtract x'C0' from the last two digits of the device number, and the corresponding CCAs are 00 through 3F.

| Device Number | Logical Control Unit Number | Channel Connection Address |
|---------------|-----------------------------|---|
| 00 - 3F | LCU00 | 00 - 3F |
| 40 - 7F | LCU01 | 00 - 3F (subtract x'40' from device number) |
| 80 - BF | LCU02 | 00 - 3F (subtract x'80' from device number) |
| C0 - FF | LCU03 | 00 - 3F (subtract x'C0' from device number) |

Appendix A. RVA Functional Device Configuration

The procedure presented here describes the steps to configure functional devices through the 9393 operator panel. Figure 21 shows the steps required to get to the Functional Device Configuration screen.

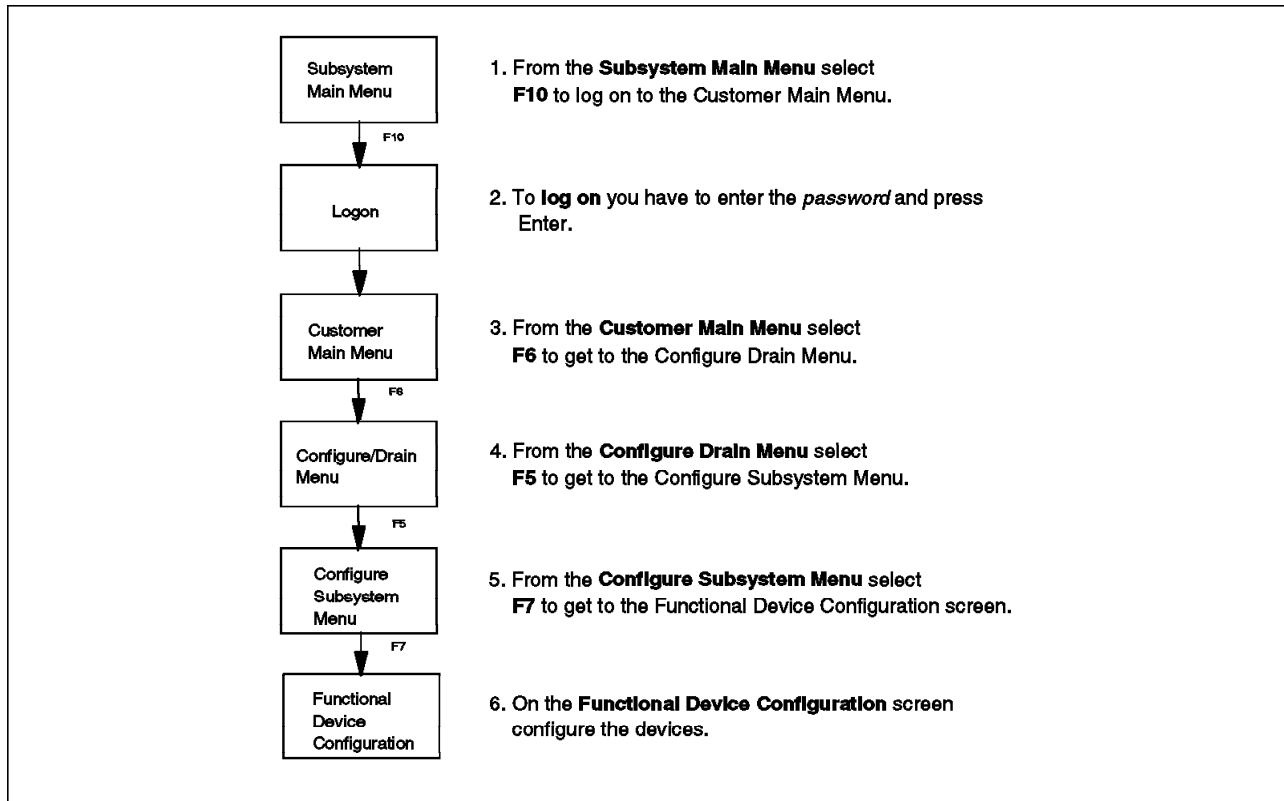

Figure 21. Functional Device Configuration

On Functional Device Configuration screen CD23 (Figure 22 on page 42) follow the steps to modify the devices:

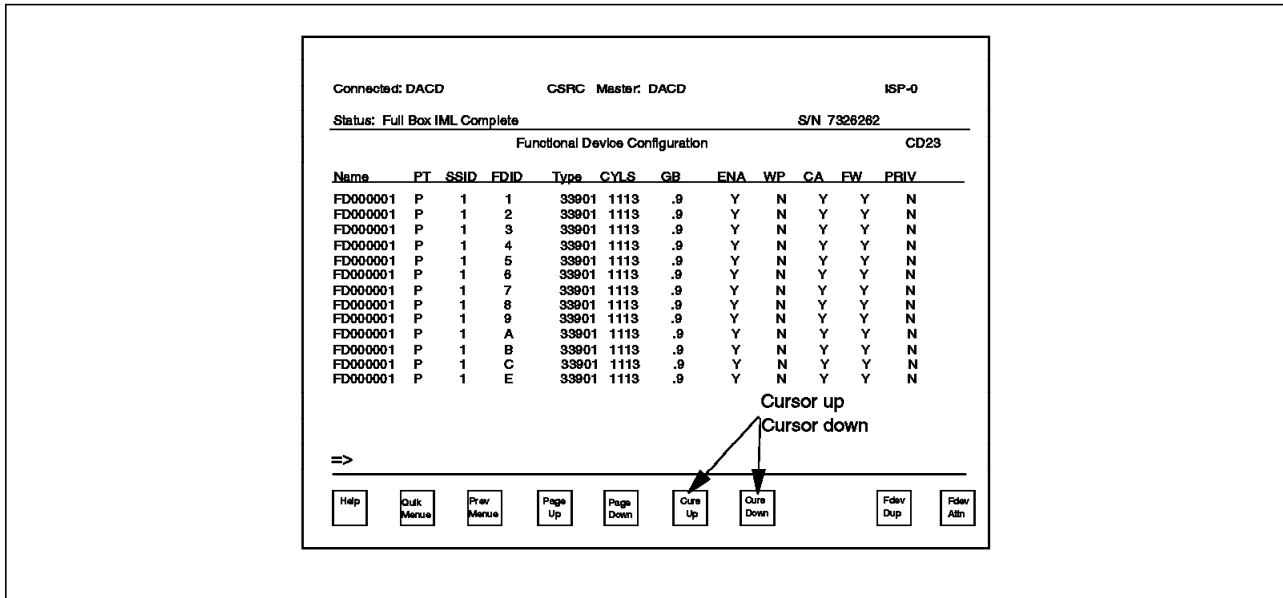

Figure 22. Functional Device Configuration Screen CD23

1. Move the cursor up or down to select the device you want to modify and press Enter to get to Modify Functional Device screen CD32 (Figure 23).

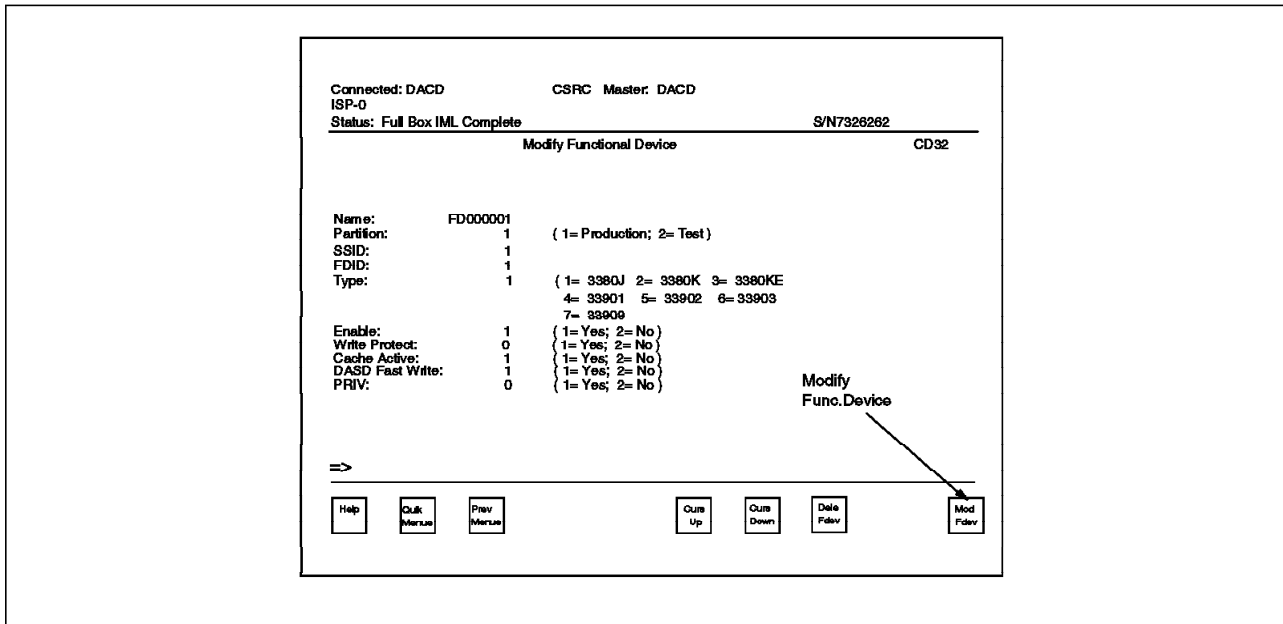

Figure 23. Modify Functional Device Screen CD32

2. On screen CD32 enter the name of the device, modify the device accordingly, and press F10 to save and go back to CD23.
3. Repeat steps 1 and 2 for each device you want to modify, or press F3 several times to leave the screen.

Appendix B. IXFP Command Examples

In this appendix we present the syntax and use of the various IXFP commands.

B.1 SNAP Command

In this section we present examples of the IXFP SNAP command. The command syntax is followed by examples of using the command.

Remember: Before you can use the SNAP option, you must bring the target offline by using the VSE/ESA DVCDN command.

B.1.1 Syntax

Figure 24 shows the syntax of the SNAP command.

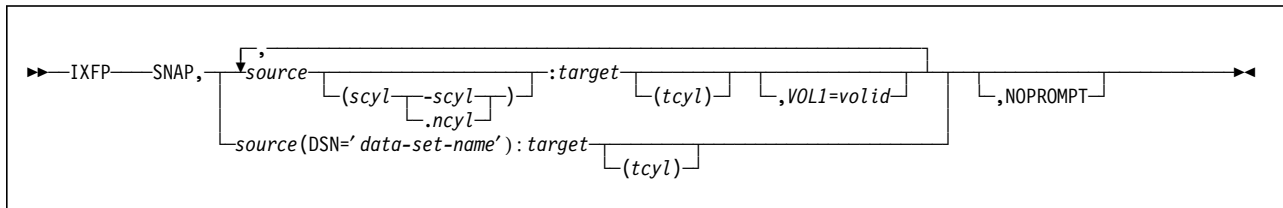

Figure 24. Syntax of IXFP SNAP Command: Details

SNAP identifies this command as a SNAP command.

source The device ID=(cuu) or the VOL1 label of the source device that the user wants to be used as the source when copying data to a target device. If the source device is identified by its VOLID, it must be either the only volume with that VOLID or the only volume with that VOLID that is up (DVCUP). Otherwise an error message will be issued. The whole volume will be copied unless the operator has provided additional information that either identifies a cylinder range or a DSN on the source device that he or she wants to be copied.

scyl-scyl Specifies the decimal start cylinder and end cylinder range where copying is to start and to end on the source device. Cylinder is the smallest entity that can be specified for any SNAP command function. The highest (end) cylinder number must not exceed 32767 or the device's primary number of cylinders and the start cylinder number must not be higher than the end cylinder number.

scyl.ncyl Specifies the decimal start cylinder where copying is to start on the source device and provides the number of cylinders (ncyl) that should be copied. Cylinder is the smallest entity that can be specified for any SNAP command function. The highest resulting cylinder number must not exceed 32767 or the device's number of primary cylinders.

DSN= The data set name identifying the file on the source device that the operator wants to be copied onto the target device. The file must be a non-VSAM file. The file will be copied into the exact extent boundaries where it was located on the source device. Sequential

access method (SAM) files, however, can be relocated to a different, single extent disk location on the target device. In this case, the `tcyl` operand must be supplied, but the device must not be a VM partial pack minidisk. The proper label information (single FORMAT-1 label) will be created and added to the target VTOC. Processing multivolume files is the responsibility of the operator, such that the SNAP command should be repeated for all the source volumes containing file extents. The number of extents to be copied is limited by the limits existing for the source device. Copying will be performed only if the appropriate extent boundaries on the target device are available or have already expired. Otherwise an error message will be issued. Use the DDSR command to delete the overlaid file and release the space.

target The device ID (`cuu`) or the VOL1 label of the target device to which the user wants the data to be copied. You must set the target device DOWN (DVCDN command) before initiating the SNAP function, unless the source and target devices are the same device. If the target device is identified by its VOLID, it must be either the only volume with that VOLID or the only volume with that VOLID that is DOWN (DVCDN). Otherwise an error message is issued. As many extents as allocated on the source device will be used for file copying to the target device (DSN=). Otherwise as many cylinders as specified for the source device, or the entire source volume will be copied to the target device. Relocation of data records will be assumed if the specified cylinder range does not match the cylinder range that was given for the source device. If the cylinder range does not match the cylinder range of the source device and the target device is a VM partial-pack minidisk, the command will be rejected because VM uses virtual cylinder values for partial-pack minidisks, and the cylinder ranges must match for VM partial-pack minidisks. The source and the target devices must be of the same type and must be in the same RVA subsystem.

tcyl The decimal specification of where copying is to start on the target device. Cylinder is the smallest entity that can be specified for any SNAP command function. The target `cyl` specification (`tcyl`) added to the specified or calculated `ncyl-1` value for the source device is the resulting target end cylinder address and must not exceed 32767 or the device's primary number of cylinders.

VOL1= Specifies the VOL1 label that the target device is to receive after the source volume has been copied. This operand is required if unique VOLIDs are to be maintained. Otherwise the source and the target devices would have the same VOL1 label after the copy function has completed. The VOL1 label specification for a target device is accepted only when both the `cyl` and the DSN= specification have been omitted, that is, for full volume snaps only.

NOPROMPT

Prevents decision-type messages from being issued. Some messages require an operator reply before the specified function is initiated. The specification of the NOPROMPT keyword causes the system to bypass this decision-type message and initiates the function without any additional notice.

Note: With the exception of file snapping (DSN=), VSE does not perform any VTOC checking on the specified target device and thus does not provide any warning message of any kind, be it overlapping extents, secured or unexpired files, or anything else. Cylinder or volume copying will be done unconditionally within the specified or assumed boundaries.

B.1.2 Using SnapShot to Copy One Volume to Another

In Figure 25 on page 46, we show the copying of one volume to another. We duplicate the contents of device 80E onto device 80F.

```

ixfp report
AR 0015 SUBSYSTEM 1321117
AR 0015 *** DEVICE    DETAIL REPORT ***
AR 0015    <---FUNC. CAPACITY (MB)---> <---CAPACITY (%)--->  PHYS.  COMP.
AR 0015 CUU  DEF  ALLOC STORED UNUSED  ALLOC  STORED UNUSED USED(MB)  RATIO
AR 0015 80E 2838.0 N/A   369.2 2468.7  N/A   13.01 86.99  213.6  1.72
AR 0015 80F 2838.0 N/A     0.8 2837.1  N/A    0.03 99.97   0.0   9.65
AR 0015
AR 0015 *** DEVICE    SUMMARY REPORT
AR 0015 CAPACITY      <-----TOTAL-----> <-----TOTALS %------>  COMP.
AR 0015  DEFINED                5676.032 MB 100.00                                RATIO
AR 0015  STORED                  370.129 MB          6.52
AR 0015  PHYS.USED                213.688 MB                                3.76  1.73
AR 0015  UNUSED                  5305.903 MB          93.48
AR 0015
AR 0015 *** SUBSYSTEM SUMMARY REPORT ***
AR 0015 SYSTEM  DEFINED-CAPACITY  DISK-ARRAY-CAP  FREE-DISK-ARRAY-CAP
AR 0015  PROD      726532.208 MB  117880.209 MB  57752.311 MB
AR 0015
AR 0015 NET-CAPACITY-LOAD(%)  COLL.-FREE-SPACE(%)  UNCOLL-FREE-SPACE(%)
AR 0015 TEST  PROD OVERALL  TEST  PROD OVERALL  TEST  PROD OVERALL
AR 0015 0.00 51.01 51.01  0.00 47.55 47.55  0.00 1.44 1.44
AR 0015 1140I  READY

```

ixfp snap,80e:80f,vol1=patev3

```

AR+0015 IXFP23D SNAP FROM CUU=80E CYL='0000' TO CUU=80F CYL='0000' NCYL='0DOB
- REPLY 'YES' TO PROCEED
15 yes
AR 0015 IXFP22I SNAP TO CUU= 80F STARTED AT 18:46:51 11/16/1998
AR 0015 IXFP20I SNAP FUNCTION COMPLETED AT 18:46:51 11/16/1998
AR 0015 1140I  READY

```

```

ixfp report
AR 0015 SUBSYSTEM 1321117
AR 0015 *** DEVICE    DETAIL REPORT ***
AR 0015    <---FUNC. CAPACITY (MB)---> <---CAPACITY (%)--->  PHYS.  COMP.
AR 0015 CUU  DEF  ALLOC STORED UNUSED  ALLOC  STORED UNUSED USED(MB)  RATIO
AR 0015 80E 2838.0 N/A   369.2 2468.7  N/A   13.01 86.99  213.6  1.72
AR 0015 80F 2838.0 N/A   369.2 2468.7  N/A   13.01 86.99  213.6  1.72
AR 0015
AR 0015 *** DEVICE    SUMMARY REPORT
AR 0015 CAPACITY      <-----TOTAL-----> <-----TOTALS %------>  COMP.
AR 0015  DEFINED                5676.032 MB 100.00                                RATIO
AR 0015  STORED                  738.558 MB          13.01
AR 0015  PHYS.USED                427.200 MB                                7.53  1.72
AR 0015  UNUSED                  4937.474 MB          86.99
AR 0015
AR 0015 *** SUBSYSTEM SUMMARY REPORT ***
AR 0015 SYSTEM  DEFINED-CAPACITY  DISK-ARRAY-CAP  FREE-DISK-ARRAY-CAP
AR 0015  PROD      726532.208 MB  117880.209 MB  57752.578 MB
AR 0015
AR 0015 NET-CAPACITY-LOAD(%)  COLL.-FREE-SPACE(%)  UNCOLL-FREE-SPACE(%)
AR 0015 TEST  PROD OVERALL  TEST  PROD OVERALL  TEST  PROD OVERALL
AR 0015 0.00 51.01 51.01  0.00 47.67 47.67  0.00 1.32 1.32
AR 0015 1140I  READY

```

Figure 25. Console Log from Volume Snap Operation

Notes: In Figure 25, in the DEVICE DETAIL REPORT, the data stored for device 80F reflects snapping the data from 80E. Also, the physical used capacity reflects its source on device 80E. The key indicator is the NET-CAPACITY-LOAD (%), which shows that the PROD capacity of the RVA has remained constant at 51.01%.

Using the VOLUME command, we verified that the target volume serial number had been changed to PATEV3.

The actual time to accomplish the copy was less than 1 sec, as indicated by messages IXFP22I and IXFP20I, which show the start and end times for the copy.

We used the above configuration as the base for all other manipulations of the RVA during the creation of this redbook. The RVA now contains two volumes, which have the same content but different volume serial numbers.

B.1.3 Using SnapShot to Copy a File from One Volume to Another

In the Figure 26, we show the snapping of a single file from one volume to another. The example shows the copy being done twice—once without the NOPROMPT option, and once with it. When NOPROMPT is selected, message IXFP23D is suppressed.

```
ixfp snap,80e(dsn=' test.data.1'):80f
AR+0015 IXFP23D SNAP FROM CUU=80E DSN=' TEST.DATA.1' TO CUU=80F - REPLY 'YES'
TO PROCEED
15 yes
AR 0015 IXFP22I SNAP TO CUU= 80F STARTED AT 11:44:44 11/20/1998
AR 0015 IXFP20I SNAP FUNCTION COMPLETED AT 11:44:44 11/20/1998
AR 0015 1I40I READY

ixfp snap,80e(dsn=' test.data.1'):80f,noprompt
AR 0015 IXFP22I SNAP TO CUU= 80F STARTED AT 18:16:59 11/17/1998
AR 0015 IXFP20I SNAP FUNCTION COMPLETED AT 18:16:59 11/17/1998
AR 0015 1I40I READY
```

Figure 26. Making a SnapShot of a Single File

B.1.4 Using SnapShot to Copy Files with Relocation

In the Figure 27 on page 48, we show two attempts to copy a file from device 80E to 80F with relocation of the data on the target volume. The first copy is successful. The second copy fails because there is already a file on the target with the same file ID in the VTOC and it is unexpired. (The first would have failed also except that the first file's expiration date had been reached.)

```

ixfp snap,80e(dsn=' test.data.1'):80f(1000),noprompt
AR 0015 IXFP22I SNAP TO CUU= 80F STARTED AT 18:52:48 11/17/1998
AR 0015 IXFP20I SNAP FUNCTION COMPLETED AT 18:52:48 11/17/1998
AR 0015 1I40I READY
ixfp snap,80e(dsn=' test.data.2'):80f(2000),noprompt
AR 0015 IXFP25I VTOC ERROR DURING WRITEANY PROCESSING RC='10' ON DEVICE=80F
AR 0015 1I40I READY

```

Figure 27. Making a SnapShot with Relocation

B.1.5 Other Uses of SnapShot

In this section we present some other uses of SnapShot in a VSE/ESA environment.

B.1.5.1 Creating a Test Copy of a VSE/ESA System

SnapShot can be used to make a copy of VSE/ESA system-resident volumes for use in testing new applications in another LPAR. Before taking the snap copy of DOSRES and SYSWK1, however, you need to be sure that all open files on these volumes have been closed. An example of this would be the shutting down of CICS. After DOSRES and SYSWK1 have been snapped, the target volumes could be reassigned from the production LPAR and reallocated to the test LPAR. You now have an exact copy of the production system's DOSRES and SYSWK1.

B.1.5.2 Copying Data from a Production Virtual Machine to a Test System

IXFP/SnapShot for VSE/ESA can be used to copy selected volumes from the production virtual machine to the test LPAR, using the procedure in B.1.5.1, "Creating a Test Copy of a VSE/ESA System." The difference here is that we have a functioning VSE/ESA system already running in the test virtual machine and now want to provide updated data to it.

An example would be that the production virtual machine has access to the full range of device addresses for the RVA—while the test virtual machine has a subset of those addresses. The addresses of the test virtual machine would be in a DVCDN condition to the production virtual machine and thus are available as a target.

In this case, the production data would be quiesced to ensure that all updates were completed. SnapShot would be invoked to copy the selected volumes to addresses accessible by the test virtual machine. The volumes would be made available again to the production virtual machine.

The test partition would then be able to use a current copy of live data for testing of new or revised applications.

Notes: The same process could be used for a data warehousing application where there is no need for up-to-the-minute information, but the full set of data is required to be in the warehouse.

The same approach could be used where the test virtual machine is assigned the task of backing up the data as a low priority virtual machine.

B.2 DDSR Command

In this section we present examples of the IXFP DDSR command.

Remember: Before you can use the DDSR option against a volume, you must bring it offline by using the DVCDN VSE/ESA command.

B.2.1 Syntax

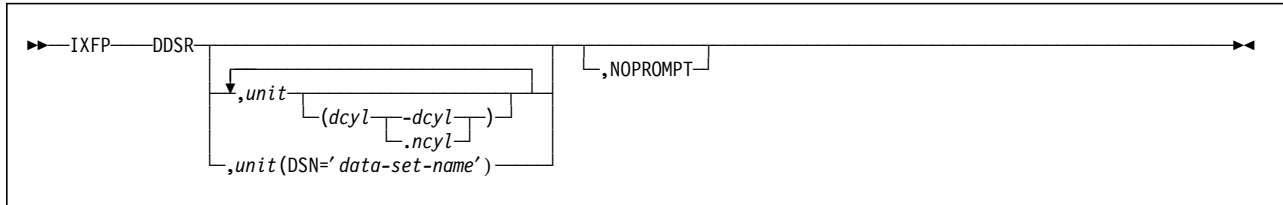

Figure 28. Syntax of IXFP DDSR Command: Details

DDSR If specified without any additional operand, the operator can delete the VTOC entries and all physical space for all non secured files residing on VSE-managed RVA devices whose associated expiration date has been reached and which have been created by VSE. A request is sent to the RVA subsystem, causing the RVA subsystem to release the physical extents that VSE considers as free space. Once released, these extents are reclaimed for free space allocation.

If a unit parameter is used, without any additional operands, the data on the entire volume will be deleted (including the VTOC and the VOL1 label). Therefore the volume must be reinitialized (ICKDSF) before it is used as a regular data-pack again, assuming it is not going to be used as a SNAP target device, in which case such an initialization run would be obsolete. VSE requires the volume to be **DOWN** (DVCDN command) if the whole volume or a range of cylinders is to be deleted.

unit The device ID (cuu) or the VOL1 label of the device that should be either totally released or, if a data set name (DSN=) or a cylinder range has been specified, partially released. The VTOC on this device will remain unchanged unless a file was released, in which case the appropriate labels will be deleted from the VTOC. If you release the whole volume, or the cylinder range containing the VTOC, the VTOC will be deleted.

dcyl-dcyl Specifies the decimal start cylinder and end cylinder where deletion is to start and to end. Cylinder is the smallest entity that can be specified for any DDSR command function. The highest (end) cylinder number must not exceed 32767, and the start cylinder number must not be higher than the end cylinder number.

dcyl.ncyl Specifies the decimal start cylinder where deletion is to start and provides the number of cylinders (ncyl) that should be released. Cylinder is the smallest entity that can be specified for any DDSR command function. The highest resulting cylinder number must not exceed 32767 or the device's number of primary cylinders.

DSN= The data set name identifying the file on the specified unit that the operator wants to be deleted. The file must be a non-VSAM file, If the specified unit is in the

UP (DVCUP) state, the file will be deleted unconditionally and the space returned to the RVA freespace. If the device is DOWN (DVCDN), the command will be rejected and an error message provided. Processing multivolume files is the responsibility of the operator, such that the DDSR command should be repeated for all volumes containing file extents.

NOPROMPT

Prevents decision-type messages from being issued. Some messages require an operator reply before the specified function is initiated. The specification of the NOPROMPT keyword causes the system to bypass this decision-type message and initiates the function without any additional notice.

B.2.2 Using DDSR to Delete a Single Data Set

To show the effects of using DDSR on the RVA, we deleted a single data set from the RVA, using the commands in Figure 29.

```
ixfp report,80f
AR 0015 SUBSYSTEM 1321117
AR 0015 *** DEVICE    DETAIL  REPORT ***
AR 0015    <---FUNC. CAPACITY (MB)---> <---CAPACITY (%)--->  PHYS.  COMP.
AR 0015 CUU  DEF  ALLOC STORED UNUSED  ALLOC  STORED  UNUSED  USED(MB)  RATIO
AR 0015 80F 2838.0 N/A   369.2 2468.7  N/A   13.01  86.99  213.6   1.72
AR 0015 1I40I  READY
ixfp ddsr,patev3(dsn='test.data.3')
AR+0015 IXFP29D DDSR FOR  CUU=80F DSN='TEST.DATA.3 - REPLY 'YES' FOR DELETION

15 yes
AR 0015 1I40I  READY
ixfp report,80f
AR 0015 SUBSYSTEM 1321117
AR 0015 *** DEVICE    DETAIL  REPORT ***
AR 0015    <---FUNC. CAPACITY (MB)---> <---CAPACITY (%)--->  PHYS.  COMP.
AR 0015 CUU  DEF  ALLOC STORED UNUSED  ALLOC  STORED  UNUSED  USED(MB)  RATIO
AR 0015 80F 2838.0 N/A   288.9 2549.0  N/A   10.18  89.82  210.6   1.37
AR 0015 1I40I  READY
```

Figure 29. Console Log from Releasing the Space of One Data Set on a Volume

B.2.3 Using DDSR to Delete the Contents of a Volume

In Figure 30 on page 51, we used the DDSR option to free the entire volume with serial number PATEV3. After the space was released, all the data and the volume serial number were erased from the volume. The volume must be reinitialized to put the volume label back on the device.

```

ixfp report,80f
AR 0015 SUBSYSTEM 1321117
AR 0015 *** DEVICE    DETAIL  REPORT ***
AR 0015    <---FUNC. CAPACITY (MB)---> <---CAPACITY (%)--->  PHYS.  COMP.
AR 0015 CUU  DEF  ALLOC STORED UNUSED  ALLOC  STORED UNUSED USED(MB)  RATIO
AR 0015 80F 2838.0 N/A   369.2 2468.7  N/A   13.01 86.99  213.6  1.72
AR 0015 1I40I  READY
ixfp ddsr,patev3
AR+0015 IXFP29D DDSR FOR  CUU=80F (WHOLE VOLUME) - REPLY 'YES' FOR DELETION
15 yes
AR 0015 1I40I  READY
ixfp report,80f
AR 0015 SUBSYSTEM 1321117
AR 0015 *** DEVICE    DETAIL  REPORT ***
AR 0015    <---FUNC. CAPACITY (MB)---> <---CAPACITY (%)--->  PHYS.  COMP.
AR 0015 CUU  DEF  ALLOC STORED UNUSED  ALLOC  STORED UNUSED USED(MB)  RATIO
AR 0015 80F 2838.0 N/A     0.0 2838.0  N/A     0.00 100.00   0.0  N/A
AR 0015 1I40I  READY

```

Figure 30. Console Log from Releasing the Space of an Entire Volume

Note: When you use DDSR, IXFP/SnapShot for VSE/ESA always prompts the operator before executing the desired function, unless the NOPROMPT keyword is selected—in which case, the function will execute without an operator prompt.

B.2.4 Using DDSR to Delete the Free Space on an RVA

Figure 31 on page 52 shows the result of using DDSR to release the space occupied by expired files in a subsystem. Both the space occupied by the data and the VTOC entry are released. (There are two occurrences of TEST.DATA.1 because device 80E was snapped to 80F.) Note that the capacity stored decreases while the capacity unused increases.

```

ixfp report,80e,80f
AR 0015 SUBSYSTEM 1321117
AR 0015 *** DEVICE    DETAIL REPORT ***
AR 0015    <---FUNC. CAPACITY (MB)---> <---CAPACITY (%)--->  PHYS.  COMP.
AR 0015 CUU  DEF  ALLOC STORED UNUSED  ALLOC  STORED UNUSED USED(MB)  RATIO
AR 0015 80E 2838.0 N/A  369.2 2468.7  N/A   13.01 86.99  213.6  1.72
AR 0015 80F 2838.0 N/A  369.2 2468.7  N/A   13.01 86.99  213.6  1.72
AR 0015 1I40I  READY
ixfp ddsr
AR+0015 IXFP26D 'TEST.DATA.1' HAS EXPIRED ON CUU=80E - REPLY 'YES' FOR
DELETION
15 yes
AR+0015 IXFP26D 'TEST.DATA.1' HAS EXPIRED ON CUU=80F - REPLY 'YES' FOR
DELETION
15 yes
AR 0015 1I40I  READY
ixfp report,80e,80f
AR 0015 SUBSYSTEM 1321117
AR 0015 *** DEVICE    DETAIL REPORT ***
AR 0015    <---FUNC. CAPACITY (MB)---> <---CAPACITY (%)--->  PHYS.  COMP.
AR 0015 CUU  DEF  ALLOC STORED UNUSED  ALLOC  STORED UNUSED USED(MB)  RATIO
AR 0015 80E 2838.0 N/A  345.6 2492.3  N/A   12.18 87.82  212.7  1.62
AR 0015 80F 2838.0 N/A  345.6 2492.3  N/A   12.18 87.82  212.7  1.62
AR 0015 1I40I  READY

```

Figure 31. Console Log from Releasing the Space of All Expired Files in the RVA

B.3 Report Command

In this section we present examples of using the IXFP REPORT command.

B.3.1 Syntax

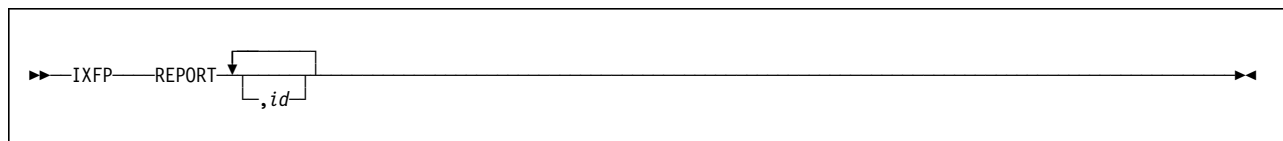

Figure 32. Syntax of IXFP REPORT Command: Details

REPORT Provides information about the utilization of the RVA devices or, if the **id** parameter has been omitted, of the whole subsystem including all devices known (ADDED) to the VSE system.

id The **id** of the device or the scope of devices for which detailed device utilization information is requested.

The **id** can be either a VOL1 label, a channel ID, a channel+CU ID, or the device ID.

"IXFP REPORT,80" will thus provide report information for all capable devices (non-partial-pack minidisks) in the device ID range X'800' through X'80F' that have been ADDED to the VSE/ESA system during IPL.

If we had specified the address for a non-RVA device, a report would not be produced. If the RVA had 256 devices specified

and they were all on channel 8, "IXFP REPORT,8" would show all the devices in the RVA, because a storage control address was not specified.

Note: The REPORT function, if used under VM, only works for full-pack minidisks or dedicated devices.

B.3.2 Reporting on the Capacity of a Single Volume

Figure 33 shows the response to a single volume request.

```
ixfp report,80e
AR 0015 SUBSYSTEM 1321117
AR 0015 *** DEVICE    DETAIL  REPORT ***
AR 0015    <---FUNC. CAPACITY (MB)---> <---CAPACITY (%)--->  PHYS.  COMP.
AR 0015 CUU  DEF  ALLOC STORED UNUSED  ALLOC  STORED  UNUSED  USED(MB)  RATIO
AR 0015 80E 2838.0 N/A  392.9 2445.1  N/A   13.84  86.16  214.4  1.83
AR 0015 1I40I  READY
```

Figure 33. Single Volume IXFP REPORT

B.3.3 Reporting on the Capacity of Multiple Volumes

Figure 34 shows the response to a multiple volume request.

```
ixfp report,80e,80f
AR 0015 SUBSYSTEM 1321117
AR 0015 *** DEVICE    DETAIL  REPORT ***
AR 0015    <---FUNC. CAPACITY (MB)---> <---CAPACITY (%)--->  PHYS.  COMP.
AR 0015 CUU  DEF  ALLOC STORED UNUSED  ALLOC  STORED  UNUSED  USED(MB)  RATIO
AR 0015 80E 2838.0 N/A  392.9 2445.1  N/A   13.84  86.16  214.4  1.83
AR 0015 80F 2838.0 N/A  392.9 2445.1  N/A   13.84  86.16  214.4  1.83
AR 0015 1I40I  READY
```

Figure 34. Multiple Volume IXFP REPORT

B.3.4 Reporting on the Capacity of the RVA Subsystem

Figure 35 on page 54 shows the response to an entire subsystem request.

```

ixfp report
AR 0015 SUBSYSTEM 1321117
AR 0015 *** DEVICE    DETAIL REPORT ***
AR 0015    <---FUNC. CAPACITY (MB)---> <---CAPACITY (%)--->  PHYS.  COMP.
AR 0015 CUU  DEF  ALLOC STORED UNUSED  ALLOC  STORED UNUSED USED(MB)  RATIO
AR 0015 80E 2838.0 N/A  392.9 2445.1  N/A   13.84 86.16  214.4  1.83
AR 0015 80F 2838.0 N/A  392.9 2445.1  N/A   13.84 86.16  214.4  1.83
AR 0015
AR 0015 *** DEVICE    SUMMARY REPORT
AR 0015 CAPACITY      <-----TOTAL-----> <-----TOTALS %------>  COMP.
AR 0015  DEFINED              5676.032 MB 100.00                                RATIO
AR 0015  STORED                785.816 MB           13.84
AR 0015  PHYS.USED             428.908 MB           7.56           1.83
AR 0015  UNUSED               4890.216 MB           86.16
AR 0015
AR 0015 *** SUBSYSTEM SUMMARY REPORT ***
AR 0015 SYSTEM  DEFINED-CAPACITY  DISK-ARRAY-CAP  FREE-DISK-ARRAY-CAP
AR 0015  PROD      726532.208 MB  117880.209 MB  57750.030 MB
AR 0015
AR 0015 NET-CAPACITY-LOAD(%)  COLL.-FREE-SPACE(%)  UNCOLL-FREE-SPACE(%)
AR 0015 TEST  PROD  OVERALL  TEST  PROD  OVERALL  TEST  PROD  OVERALL
AR 0015 0.00 51.01 51.01  0.00 47.55 47.55  0.00 1.44 1.44
AR 0015 1I40I  READY

```

Figure 35. Entire Subsystem IXFP REPORT

Submitting the batch job shown in Figure 36 would achieve the same results.

```

// JOB WCWTEST1
// LOG
// EXEC DTRIATTN,PARM=' IXFP REPORT'
/&

```

Figure 36. JCL to Produce an Entire Subsystem IXFP REPORT

B.4 IXFP/SnapShot Setup Job Streams

For the verification of IXFP/SnapShot for VSE/ESA, two RVA disks were made available. In this section we present the job streams used to allocate and create the test data. We used the following job stream to release the space on the RVA and write the VTOCs to the disks:

```

// JOB INITDISK
  DVCN X'80E'
// EXEC DTRIATTN,PARM=' IXFP DDSR,80E'
  DVCN X'80F'
// EXEC DTRIATTN,PARM=' IXFP DDSR,80F'
// LOG
* WAIT UNTIL IXFP/SNAPSHOT HAS RELEASED THE SPACE BEFORE CONTINUING
// EXEC IESWAIT
  DVCUP X'80E'
  DVCUP X'80F'
// ASSGN SYS004,80E,SHR
// EXEC ICKDSF,SIZE=AUTO

```



```

INIT SYSNAME(SYS004) NOVERIFY PURGE VOLID(PATEV1)
/*
// ASSGN SYS004,80F,SHR
// EXEC ICKDSF,SIZE=AUTO
INIT SYSNAME(SYS004) NOVERIFY PURGE VOLID(PATEV2)
/*
/&

```

Figure 37 shows the console log from the above job stream. Notice that we used DDSR to free any extraneous space on the disks.

```

BG 0000 // JOB INITDISK
      DATE 11/16/1998, CLOCK 14/39/38
BG 0000 1A86I FOLLOWING ASSIGNMENTS ARE RELEASED
BG 0000      ** NONE **
IXFP DDSR,80E
AR+0015 IXFP29D DDSR FOR CUU=80E (WHOLE VOLUME) - REPLY 'YES' FOR DELETION
BG 0000 1A86I FOLLOWING ASSIGNMENTS ARE RELEASED
BG 0000      ** NONE **
15 yes
AR 0015 1I40I READY
IXFP DDSR,80F
AR+0015 IXFP29D DDSR FOR CUU=80F (WHOLE VOLUME) - REPLY 'YES' FOR DELETION
BG 0000 * WAIT UNTIL IXFP/SNAPSHOT HAS RELEASED THE SPACE BEFORE CONTINUING
15 yes
AR 0015 1I40I READY
BG 0000 DVCUP X'80E'
BG 0000 DVCUP X'80F'
BG 0000 EOJ INITDISK MAX.RETURN CODE=0000
      DATE 11/16/1998, CLOCK 14/40/03, DURATION 00/00/24

```

Figure 37. Console Log from Formatting RVA to Receive Test Data

Figure 38 on page 56 shows the report of the setup job. Notice that there is no data stored on either of the volumes.

```

ixfp report
AR 0015 SUBSYSTEM 1321117
AR 0015 *** DEVICE    DETAIL REPORT ***
AR 0015    <---FUNC. CAPACITY (MB)---> <---CAPACITY (%)--->  PHYS.  COMP.
AR 0015 CUU  DEF  ALLOC STORED UNUSED  ALLOC  STORED UNUSED USED(MB)  RATIO
AR 0015 80E 2838.0 N/A    0.0 2838.0  N/A    0.00 100.00   0.0  N/A
AR 0015 80F 2838.0 N/A    0.0 2838.0  N/A    0.00 100.00   0.0  N/A
AR 0015
AR 0015 *** DEVICE    SUMMARY REPORT
AR 0015 CAPACITY      <-----TOTAL-----> <-----TOTALS %------>  COMP.
AR 0015  DEFINED                5676.032 MB  100.00                                RATIO
AR 0015  STORED                  0.000 MB           0.00
AR 0015  PHYS.USED                0.000 MB           0.00      0.00
AR 0015  UNUSED                  5676.032 MB       100.00
AR 0015
AR 0015 *** SUBSYSTEM SUMMARY REPORT ***
AR 0015 SYSTEM  DEFINED-CAPACITY  DISK-ARRAY-CAP  FREE-DISK-ARRAY-CAP
AR 0015  PROD      726532.208 MB   117880.209 MB   57966.680 MB
AR 0015
AR 0015 NET-CAPACITY-LOAD(%)  COLL.-FREE-SPACE(%)  UNCOLL-FREE-SPACE(%)
AR 0015 TEST  PROD  OVERALL  TEST  PROD  OVERALL  TEST  PROD  OVERALL
AR 0015 0.00 50.83 50.83  0.00 47.86 47.86  0.00 1.31 1.31
AR 0015 1I40I  READY

```

Figure 38. RVA Status before Loading Any Data

We used the following job stream (which uses DITTO to create six files) to load the data onto the RVA:

```

// JOB BUILD DATA ON PATEV1 (80E)
// OPTION NODUMP
// ASSGN SYS005,DISK,VOL=PATEV1,SHR
// DLBL OUTPUT,' EXPIRED.DSF.DATA.FILE',1998/300,SD,DSF
// EXTENT SYS005,PATEV1,1,1,4035,1500
// UPSI 1
// LOG
* DISPLAY RVA DATA FOR PATEV1 (80E) -- BEFORE DATA LOAD.
// NOLOG
// EXEC DTRIATTN,PARM=' IXFP REPORT,PATEV1'
// LOG
* BUILD EXPIRED, DATA-SECURED FILE ON 80E
*      17,000 RECORDS, 4,000 BYTES LONG, RANDOM FILL CHARACTER
// NOLOG
// EXEC DITTO,SIZE=AUTO
$$DITTO BSQ FILEOUT=OUTPUT,RECSIZE=4000,NLRECS=17000,FILLCHAR=RAND,    X
$$DITTO      BLKFACTOR=1
$$DITTO EOJ
/*
// DLBL OUTPUT,' UNEXPIRED.DSF.DATA.FILE',1998/365,SD,DSF
// EXTENT SYS005,PATEV1,1,1,5535,1500
// LOG
* BUILD UNEXPIRED, DATA-SECURED FILE ON 80E
*      17,000 RECORDS, 4,000 BYTES LONG, RANDOM FILL CHARACTER
// NOLOG
// EXEC DITTO,SIZE=AUTO
$$DITTO BSQ FILEOUT=OUTPUT,RECSIZE=4000,NLRECS=17000,FILLCHAR=RAND,    X
$$DITTO      BLKFACTOR=1
$$DITTO EOJ

```

```

/*
// DLBL OUTPUT,'TEST.DATA.1',1998/300,SD
// EXTENT SYS005,PATEV1,1,1,135,450
// LOG
* BUILD EXPIRED SEQUENTIAL FILE ON 80E
*      5,000 RECORDS, 4,000 BYTES LONG, "1" FILL CHARACTER
// NOLOG
// EXEC DITTO,SIZE=AUTO
$$DITTO BSQ FILEOUT=OUTPUT,RECSIZE=4000,NLRECS=5000,FILLCHAR=1,      X
$$DITTO      BLKFACTOR=1
$$DITTO EOJ
/*
// DLBL OUTPUT,'TEST.DATA.2',,SD
// EXTENT SYS005,PATEV1,1,1,585,450
// LOG
* BUILD SEQUENTIAL FILE ON 80E
*      5,000 RECORDS, 4,000 BYTES LONG, "2" FILL CHARACTER
// NOLOG
// EXEC DITTO,SIZE=AUTO
$$DITTO BSQ FILEOUT=OUTPUT,RECSIZE=4000,NLRECS=5000,FILLCHAR=2,      X
$$DITTO      BLKFACTOR=1
$$DITTO EOJ
/*
// DLBL OUTPUT,'TEST.DATA.3',,SD
// EXTENT SYS005,PATEV1,1,1,1035,1500
// LOG
* BUILD SEQUENTIAL FILE ON 80E
*      17,000 RECORDS, 4,000 BYTES LONG, "3" FILL CHARACTER
// NOLOG
// EXEC DITTO,SIZE=AUTO
$$DITTO BSQ FILEOUT=OUTPUT,RECSIZE=4000,NLRECS=17000,FILLCHAR=3,      X
$$DITTO      BLKFACTOR=1
$$DITTO EOJ
/*
* BUILD SEQUENTIAL FILE ON 80E
*      5,000 RECORDS, 4,000 BYTES LONG, "1" FILL
// LOG
* BUILD SEQUENTIAL FILE ON 80E
*      17,000 RECORDS, 4,000 BYTES LONG, RANDOM FILL CHARACTER
// NOLOG
// EXEC DITTO,SIZE=AUTO
$$DITTO BSQ FILEOUT=OUTPUT,RECSIZE=4000,NLRECS=17000,FILLCHAR=RAND,      X
$$DITTO      BLKFACTOR=1
$$DITTO EOJ
/*
// LOG
* DISPLAY RVA DATA FOR PATEV1 (80E) -- AFTER DATA LOAD.
// NOLOG
// EXEC DTRIATTN,PARM='IXFP REPORT,PATEV1'
// EXEC IESWAIT
// EXEC LISTLOG
/&

```

The result (Figure 39 on page 58) is six sequential files with varying types of data. Two of the files are data secured to prevent "unauthorized" access. Three of the files are highly compressible because they contain a repeating data character, and the other three have random fill characters.

```

ixfp report
AR 0015 SUBSYSTEM 1321117
AR 0015 *** DEVICE    DETAIL REPORT ***
AR 0015    <----FUNC. CAPACITY (MB)----> <----CAPACITY (%)---->  PHYS.  COMP.
AR 0015 CUU   DEF   ALLOC STORED UNUSED  ALLOC  STORED UNUSED USED(MB)  RATIO
AR 0015 80E 2838.0 N/A   369.2 2468.7  N/A   13.01 86.99  213.6  1.72
AR 0015 80F 2838.0 N/A     0.8 2837.1  N/A    0.03 99.97   0.0   9.65
AR 0015
AR 0015 *** DEVICE    SUMMARY REPORT
AR 0015 CAPACITY      <-----TOTAL-----> <-----TOTALS %------>  COMP.
AR 0015   DEFINED                5676.032 MB 100.00                                RATIO
AR 0015   STORED                  370.129 MB           6.52
AR 0015   PHYS.USED                213.688 MB           3.76      1.73
AR 0015   UNUSED                  5305.903 MB           93.48
AR 0015
AR 0015 *** SUBSYSTEM SUMMARY REPORT ***
AR 0015 SYSTEM   DEFINED-CAPACITY   DISK-ARRAY-CAP  FREE-DISK-ARRAY-CAP
AR 0015  PROD     726532.208 MB     117880.209 MB   57754.953 MB
AR 0015
AR 0015 NET-CAPACITY-LOAD(%)  COLL.-FREE-SPACE(%)  UNCOLL-FREE-SPACE(%)
AR 0015 TEST  PROD OVERALL  TEST  PROD OVERALL  TEST  PROD OVERALL
AR 0015 0.00 51.01 51.01  0.00 47.67 47.67  0.00 1.32 1.32
AR 0015 1I40I  READY

```

Figure 39. RVA Status after Loading Data

Appendix C. VSE/VSAM Considerations

VSE/VSAM support is not included in IXFP/SnapShot for VSE/ESA. This does not mean however that you cannot take advantage of IXFP/SnapShot for VSE/ESA with VSE/VSAM data sets.

It does mean that there is no support in IXFP/SnapShot for VSE/ESA to dynamically adjust the VSAM catalog to reflect the target of the SnapShot copy. However, through job control, a user catalog can point to the SnapShot copy and access the data on the copy. In our test, we created a VSAM user catalog (UCAT), space, and cluster on a volume at address 80E with serial number PATEV1. We then snapped the volume to device address 80F with serial number PATEV2, changing the volume serial number to PATEV1 in the process using the following procedure:

1. Close any opened files on the volume. (This may include shutting down CICS or other applications.)

2. Issue the following commands:

```
0 dvcdn 80f
ixfp snap,patev1:80f,vol1=patev1
0 dvcup 80f
```

3. The JCL to access the source volume is:

```
// DLBL UCAT01,'VOLSER.USER.CATALOG',,VSAM
// DLBL DDNAME,'USER.FILE.ID',,VSAM,CAT=UCAT01
```

4. To process data from the target volume, use the following JCL to access the VSAM file:

```
// DLBL UCAT01,'VOLSER.USER.CATALOG',,VSAM
// EXTENT SYS099,PATEV1
// ASSGN SYS099,80F,SHR
// DLBL DDNAME,'USER.FILE.ID',,VSAM,CAT=UCAT01
// EXTENT SYS099,PATEV1
```

The first JCL finds the source volume because its device address is lower than the target volume's. The second JCL can only use the data from device address 80F because we have explicitly pointed to that device with the ASSGN statement. In this case, we can access the snapped copy of the VSAM files on device 80F and copy it to the original volume, if required as part of a recovery effort.

5. After using the target volume and its VSAM file, release the space back to the RVA by issuing the **ixfp ddsr 80f** command. (Remember that 80F would have to be DVCDNed before the IXFP DDSR command could be successfully executed.) You can also retain it online for use in a VSE/ESA partition—as long as the duplicate volume serial number and UCAT will not create a problem.

Warning

This approach may not work with VSAM files that specify share options 2 or 4. The reason for the problem here is that, with SHROPTN(2), or SHROPTN(4), VSE/VSAM's method of enqueueing the file (to protect it during a write) uses the file ID of the VSAM catalog and the volume serial number of the volume.

Notes:

Share option 2 provides that the file may be opened by more than one request for input processing and, at the same time, by one request for output processing. This option ensures write integrity; however, the file might be modified while records are retrieved from it, so every user must ensure his or her own file's read integrity.

Share option 4 provides that a key-sequenced or relative-record file can be opened by any number of requests (ACBs) for both input and output processing by users in the first system requesting output to the file. Once a file has been opened for output by one system, VSE/VSAM accepts only open for input requests from another system. Share option 4 for an entry-sequenced file is treated as though it were a share option 2.

If, for any reason, the file were to be opened for output processing while the target is online to the VSE/ESA system, return code x'A8' (168) might be returned indicating that the data set is in use. This is caused by the lock with duplicate volume serial numbers. The situation can be corrected by canceling and restarting the job after taking the target offline; there is no data integrity exposure.

C.1 Backing up VSAM Volumes

There are several instances where SnapShot can be used to back up VSAM volumes for use within the same LPAR or different LPARs. In a first example, we wanted to copy a VSAM volume that contained both the user catalog (UCAT) and all of the UCAT's files on a single volume. In this case, we would make a snap copy of the volume with the target volume having a volume serial number different from that of the source. Before we actually issue the IXFP SNAP command, any files that are open have to be closed so that the data is written to the disk. Then a utility like VSE/FASTCOPY or the VM/ESA DDR could be used to back up the volume to tape. If all that we were trying to establish was a restart copy in case there was an application failure, the tape backup is superfluous. The VSAM volume cannot be used because the VSAM catalog's contents include the volume serial number of the volume on which it was created. If VSAM finds a different volume serial number, it cannot process the catalog.

In a second example, the VSAM files reside on several volumes and have a unique UCAT for these files. Here, we would use the same procedure as above to quiesce activity against the files. The volumes containing the files would then be snap copied and, optionally, backed up to tape.

In a third example, we again have one or more VSAM volumes controlled by a single UCAT. This time, we would like to carry the data from our production

LPAR to a test LPAR. We would quiesce the files as above. And we would also make the SnapShot copy. But, this time, the volume serial number of the source would be retained on the target. Because the target volume for a SNAP copy is always in a DVCDN condition, the duplicate volume serial number would not interfere with the production system. The target volumes would then be taken away from the VSE production system through the use of the **offline** command. The volumes would then be placed online to the test LPAR and then, using the IDCAMS IMPORT CONNECT to access the UCAT, you can use the files in the test LPAR. In this case, IDCAMS BACKUP could be used to back up the files.

Appendix D. IOCDS Example

IOCDS must have an LCU defined for each group of 64 functional devices. Each LCU should have two CNTLUNIT macros, one for each cluster.

Figure 40 shows a sample IOCDS from the RVA.

```
CHPID    PATH=((0A),(0B),(0C),(0D)),TYPE=CNC
```

```
CNTLUNIT CUNUMBR=001,  
        UNIT=3990,  
        UNITADD=((00,64)),  
        PATH=(0A,0B),  
        CUADD=2
```

```
CNTLUNIT CUNUMBR=002,  
        UNIT=3990,  
        UNITADD=((00,64)),  
        PATH=(0C,0D),  
        CUADD=2
```

```
CNTLUNIT CUNUMBR=003,  
        UNIT=3990,  
        UNITADD=((00,64)),  
        PATH=(0A,0B),  
        CUADD=3
```

```
CNTLUNIT CUNUMBR=004,  
        UNIT=3990,  
        UNITADD=((00,64)),  
        PATH=(0C,0D),  
        CUADD=3
```

```
IODEVICE UNIT=3390,  
        ADDRESS=(180,64),  
        UNITADD=00,  
        STADET=Y,  
        CUNUMBR=(001,002),
```

```
IODEVICE UNIT=3390,  
        ADDRESS=(1C0,64),  
        UNITADD=00,  
        STADET=Y,  
        CUNUMBR=(003,004),
```

Figure 40. IOCDS Example

Appendix E. Special Notices

This publication is intended to help IBM, Business Partner, and customer personnel understand how VSE/ESA provides support for the RAMAC Virtual Array. The information in this publication is not intended as the specification of any programming interfaces that are provided by IXFP/SnapShot for VSE/ESA, RAMAC Virtual Array, and peer-to-peer remote copy. See the PUBLICATIONS section of the IBM Programming Announcement for IXFP/SnapShot for VSE/ESA and peer-to-peer remote copy for the RAMAC Virtual Array for more information about what publications are considered to be product documentation.

References in this publication to IBM products, programs or services do not imply that IBM intends to make these available in all countries in which IBM operates. Any reference to an IBM product, program, or service is not intended to state or imply that only IBM's product, program, or service may be used. Any functionally equivalent program that does not infringe any of IBM's intellectual property rights may be used instead of the IBM product, program or service.

Information in this book was developed in conjunction with use of the equipment specified, and is limited in application to those specific hardware and software products and levels.

IBM may have patents or pending patent applications covering subject matter in this document. The furnishing of this document does not give you any license to these patents. You can send license inquiries, in writing, to the IBM Director of Licensing, IBM Corporation, North Castle Drive, Armonk, NY 10504-1785.

Licensees of this program who wish to have information about it for the purpose of enabling: (i) the exchange of information between independently created programs and other programs (including this one) and (ii) the mutual use of the information which has been exchanged, should contact IBM Corporation, Dept. 600A, Mail Drop 1329, Somers, NY 10589 USA.

Such information may be available, subject to appropriate terms and conditions, including in some cases, payment of a fee.

The information contained in this document has not been submitted to any formal IBM test and is distributed AS IS. The information about non-IBM ("vendor") products in this manual has been supplied by the vendor and IBM assumes no responsibility for its accuracy or completeness. The use of this information or the implementation of any of these techniques is a customer responsibility and depends on the customer's ability to evaluate and integrate them into the customer's operational environment. While each item may have been reviewed by IBM for accuracy in a specific situation, there is no guarantee that the same or similar results will be obtained elsewhere. Customers attempting to adapt these techniques to their own environments do so at their own risk.

Any pointers in this publication to external Web sites are provided for convenience only and do not in any manner serve as an endorsement of these Web sites.

Any performance data contained in this document was determined in a controlled environment, and therefore, the results that may be obtained in other

operating environments may vary significantly. Users of this document should verify the applicable data for their specific environment.

Reference to PTF numbers that have not been released through the normal distribution process does not imply general availability. The purpose of including these reference numbers is to alert IBM customers to specific information relative to the implementation of the PTF when it becomes available to each customer according to the normal IBM PTF distribution process.

The following terms are trademarks of the International Business Machines Corporation in the United States and/or other countries:

| | |
|---------|--------|
| CICS | DFSORT |
| ECKD | ESCON |
| IBM | OS/390 |
| RAMAC | VM/ESA |
| VSE/ESA | |

The following terms are trademarks of other companies:

| | |
|------------|--------------------------------|
| IXFP | Storage Technology Corporation |
| Iceberg | Storage Technology Corporation |
| StorageTek | Storage Technology Corporation |

C-bus is a trademark of Corollary, Inc.

Java and HotJava are trademarks of Sun Microsystems, Incorporated.

Microsoft, Windows, Windows NT, and the Windows 95 logo are trademarks or registered trademarks of Microsoft Corporation.

PC Direct is a trademark of Ziff Communications Company and is used by IBM Corporation under license.

Pentium, MMX, ProShare, LANDesk, and ActionMedia are trademarks or registered trademarks of Intel Corporation in the U.S. and other countries.

UNIX is a registered trademark in the United States and other countries licensed exclusively through X/Open Company Limited.

Other company, product, and service names may be trademarks or service marks of others.

Appendix F. Related Publications

The publications listed in this section are considered particularly suitable for a more detailed discussion of the topics covered in this redbook.

F.1 International Technical Support Organization Publications

For information on ordering these ITSO publications see "How to Get ITSO Redbooks" on page 69.

- *IBM RAMAC Virtual Array*, SG24-4951
- *RAMAC Virtual Array: Implementing Peer-to-Peer Remote Copy*, SG24-5338
- *Implementing SnapShot*, SG24-2241

F.2 Redbooks on CD-ROMs

Redbooks are also available on CD-ROMs. **Order a subscription** and receive updates 2-4 times a year.

| CD-ROM Title | Subscription Number | Collection Kit Number |
|---|---------------------|-----------------------|
| System/390 Redbooks Collection | SBOF-7201 | SK2T-2177 |
| Networking and Systems Management Redbooks Collection | SBOF-7370 | SK2T-6022 |
| Transaction Processing and Data Management Redbook | SBOF-7240 | SK2T-8038 |
| Lotus Redbooks Collection | SBOF-6899 | SK2T-8039 |
| Tivoli Redbooks Collection | SBOF-6898 | SK2T-8044 |
| AS/400 Redbooks Collection | SBOF-7270 | SK2T-2849 |
| RS/6000 Redbooks Collection (HTML, BkMgr) | SBOF-7230 | SK2T-8040 |
| RS/6000 Redbooks Collection (PostScript) | SBOF-7205 | SK2T-8041 |
| RS/6000 Redbooks Collection (PDF Format) | SBOF-8700 | SK2T-8043 |
| Application Development Redbooks Collection | SBOF-7290 | SK2T-8037 |

F.3 Other Publications

These publications are also relevant as further information sources:

- *Device Support Facilities User's Guide and Reference, Release 16 Refresh with Peer-to-Peer Remote Copy*, GC35-0033
- *IOCP User's Guide and ESCON Channel-to-Channel Reference*, GC38-0401
- *Memo to Licensees* (ships with the IXFP/SnapShot for VSE/ESA feature)

How to Get ITSO Redbooks

This section explains how both customers and IBM employees can find out about ITSO redbooks, redpieces, and CD-ROMs. A form for ordering books and CD-ROMs by fax or e-mail is also provided.

- **Redbooks Web Site** <http://www.redbooks.ibm.com/>

Search for, view, download or order hardcopy/CD-ROMs redbooks from the redbooks Web site. Also read redpieces and download additional materials (code samples or diskette/CD-ROM images) from this redbooks site.

Redpieces are redbooks in progress; not all redbooks become redpieces and sometimes just a few chapters will be published this way. The intent is to get the information out much quicker than the formal publishing process allows.

- **E-mail Orders**

Send orders via e-mail including information from the redbook order form to:

| | IBMMAIL | Internet |
|------------------------|---------------------|----------------------|
| In United States: | usib6fpl at ibmmail | usib6fpl@ibmmail.com |
| In Canada: | caibmbkz at ibmmail | lmannix@vnet.ibm.com |
| Outside North America: | dkibmbsh at ibmmail | bookshop@dk.ibm.com |

- **Telephone Orders**

| | | |
|---------------------------|-------------------------------|-----------------------------|
| United States (toll free) | 1-800-879-2755 | |
| Canada (toll free) | 1-800-IBM-4YOU | |
| Outside North America | (long distance charges apply) | |
| (+45) 4810-1320 - Danish | (+45) 4810-1220 - French | (+45) 4810-1270 - Norwegian |
| (+45) 4810-1420 - Dutch | (+45) 4810-1020 - German | (+45) 4810-1120 - Spanish |
| (+45) 4810-1540 - English | (+45) 4810-1620 - Italian | (+45) 4810-1170 - Swedish |
| (+45) 4810-1670 - Finnish | | |

This information was current at the time of publication, but is continually subject to change. The latest information for customers may be found at <http://www.redbooks.ibm.com/> and for IBM employees at <http://w3.itso.ibm.com/>.

IBM Intranet for Employees

IBM employees may register for information on workshops, residencies, and redbooks by accessing the IBM Intranet Web site at <http://w3.itso.ibm.com/> and clicking the ITSO Mailing List button. Look in the Materials repository for workshops, presentations, papers, and Web pages developed and written by the ITSO technical professionals; click the Additional Materials button. Employees may also view redbook, residency and workshop announcements at <http://inews.ibm.com/>.

IBM Redbook Fax Order Form

Fax your redbook orders to:

| | |
|---------------------------|---|
| United States (toll free) | 1-800-445-9269 |
| Canada | 1-403-267-4455 |
| Outside North America | (+45) 48 14 2207 (long distance charge) |

Please send me the following:

| Title | Order Number | Quantity |
|-------|--------------|----------|
| | | |
| | | |
| | | |
| | | |
| | | |
| | | |
| | | |
| | | |
| | | |

First name Last name

Company

Address

City Postal code Country

Telephone number Telefax number VAT number

• Invoice to customer number

• Credit card number

Credit card expiration date Card issued to Signature

We accept American Express, Diners, Eurocard, Master Card, and Visa. Payment by credit card not available in all countries. Signature mandatory for credit card payment.

Index

B

- batch
 - application processing 10
 - data set reorganization 9
 - incremental backup 9
 - interim backup 10
 - report generation 10

C

- catalog
 - implications 4
- CKD 1
- compaction 2
- compression 2
- configuration
 - device 41
- count key data
 - See CKD

D

- data placement 8
- DDSR
 - command detail 49
 - command syntax 25
 - cylinder range 26
 - example 50
 - expired files 25
 - file 27
 - volume 26
- deleted data space release
 - See DDSR
- device definition 41
- device emulation 14
- dynamic configuration 10

E

- ESCON connectivity 14

F

- FBA 1
- FDT 1
- fixed block architecture
 - See FBA
- freespace collection 1
- FTD 1
- FTT 2
- functional device
 - description 1
- functional device definition 41

- functional device table
 - See FDT
- functional track directory
 - See FTD
- functional track table
 - See FTT

H

- hardware
 - availability 10
 - requirements 13

I

- I/O configuration definition data set
 - See IOCDs
- I/O Configuration Program
 - See IOCP
- IBM Extended Facilities Program
 - See IXFP
- ICKDSF
 - commands 15
 - initialization 15
- IOCDs
 - example 63
- IOCP
 - definition 14
- IXFP
 - function 1
- IXFP/SnapShot for VSE/ESA
 - command environment 17
 - command syntax 20
 - functions 17

L

- LIC requirements 13

N

- NCL
 - description 1
- net capacity load
 - See NCL

P

- peer-to-peer remote copy
 - See PPRC
- physical copy 3
- PPRC 5
 - addressing 38
 - benefits 33
 - command syntax 36

PPRC (*continued*)
 distance 33
 hardware requirements 34
 operation 33
 PPRCOPY command 35
 recovery 37
 SnapShot considerations 36
 software requirements 34
PPRCOPY command
 parameters 35

R

REPORT

 command detail 52
 command syntax 27
 device detail 29
 device summary 31
 example 53
 sample output 54
requirements
 PPRC 34

S

SnapShot

 architecture 3
 command details 43
 command syntax 21
 cylinder range 23
 example 45
 file relocation 47
 file snap 24
 logical copy 3
 operation 4
 PPRC considerations 36
 resources 3
 test system 48
 volume snap 21
 VSE/VSAM 22, 59
software
 requirements 13
space management 7
storage management 7
system testing
 SnapShot 48

T

TNT

 description 2
 reference counter 2, 4
track number table
 See TNT

U

update in place 1

V

virtual disk architecture 1
VM minidisks 17
VSE/VSAM
 sample JCL 59
 SnapShot 22, 59
 volume backup 60

ITSO Redbook Evaluation

RAMAC Virtual Array, Peer-to-Peer Remote Copy,
SG24-5360-00

Your feedback is very important to help us maintain the quality of ITSO redbooks. **Please complete this questionnaire and Fax it to: USA International Access Code + 1 914 432 8264 or:**

- Use the online evaluation form found at <http://www.redbooks.ibm.com>
- Send your comments in an Internet note to redbook@us.ibm.com

Which of the following best describes you?

Customer **Business Partner** **Solution Developer** **IBM employee**
 None of the above

Please rate your overall satisfaction with this book using the scale:
(1 = very good, 2 = good, 3 = average, 4 = poor, 5 = very poor)

Overall Satisfaction _____

Please answer the following questions:

Was this redbook published in time for your needs? Yes____ No____

If no, please explain:

What other redbooks would you like to see published?

Comments/Suggestions: **(THANK YOU FOR YOUR FEEDBACK!)**



Free Manuals Download Website

<http://myh66.com>

<http://usermanuals.us>

<http://www.somanuals.com>

<http://www.4manuals.cc>

<http://www.manual-lib.com>

<http://www.404manual.com>

<http://www.luxmanual.com>

<http://aubethermostatmanual.com>

Golf course search by state

<http://golfingnear.com>

Email search by domain

<http://emailbydomain.com>

Auto manuals search

<http://auto.somanuals.com>

TV manuals search

<http://tv.somanuals.com>