

**iCOM**

**SERVICE  
MANUAL**

MULTIBAND FM TRANSCEIVER

**IC-T90A**

---

---

---

---

---

**Icom Inc.**

---

## INTRODUCTION

---

This service manual describes the latest service information for the IC-T90A MULTIBAND FM TRANSCEIVER at the time of publication.

MODEL	VERSION	SYMBOL
T90A	U.S.A.	USA
	General	GEN
	Canada	CAN
	S.E. Asia	SEA

**To upgrade quality, all electrical or mechanical parts and internal circuits are subject to change without notice or obligation.**

---

## DANGER

---

**NEVER** connect the transceiver to an AC outlet or to a DC power supply that uses more than 12 V. Such a connection could cause a fire hazard and/or electric.

**DO NOT** expose the transceiver to rain, snow or any liquids.

**DO NOT** reverse the polarities of the power supply when connecting the transceiver.

**DO NOT** apply an RF signal of more than 20 dBm (100 mW) to the antenna connector. This could damage the transceiver's front end.

---

## ORDERING PARTS

---

Be sure to include the following four points when ordering replacement parts:

1. 10-digit order numbers
2. Component part number and name
3. Equipment model name and unit name
4. Quantity required

**<SAMPLE ORDER>**

1130006220 S.IC TC4W53FU IC-T90A LOGIC UNIT 1 piece  
8930054290 2372 Main seal IC-T90A Chassis 5 pieces

Addresses are provided on the inside back cover for your convenience.



---

## REPAIR NOTES

---

1. Make sure a problem is internal before disassembling the transceiver.
2. **DO NOT** open the transceiver until the transceiver is disconnected from its power source.
3. **DO NOT** force any of the variable components. Turn them slowly and smoothly.
4. **DO NOT** short any circuits or electronic parts. An insulated tuning tool **MUST** be used for all adjustments.
5. **DO NOT** keep power ON for a long time when the transceiver is defective.
6. **DO NOT** transmit power into a signal generator or a sweep generator.
7. **ALWAYS** connect a 40 dB or 50 dB attenuator between the transceiver and a deviation meter or spectrum analyser when using such test equipment.
8. **READ** the instructions of test equipment thoroughly before connecting equipment to the transceiver.

---

## TABLE OF CONTENTS

---

<b>SECTION 1</b>	<b>SPECIFICATIONS</b>	
<b>SECTION 2</b>	<b>INSIDE VIEWS</b>	
<b>SECTION 3</b>	<b>DISASSEMBLY INSTRUCTIONS</b>	
<b>SECTION 4</b>	<b>CIRCUIT DESCRIPTION</b>	
4 - 1	RECEIVER CIRCUITS .....	4 - 1
4 - 2	TRANSMITTER CIRCUITS .....	4 - 4
4 - 3	PLL CIRCUITS.....	4 - 5
4 - 4	POWER SUPPLY CIRCUITS .....	4 - 7
4 - 5	PORT ALLOCATIONS .....	4 - 7
<b>SECTION 5</b>	<b>ADJUSTMENT PROCEDURES</b>	
5 - 1	PREPARATION.....	5 - 1
5 - 2	TRIMMER ADJUSTMENT .....	5 - 3
5 - 3	ADJUSTMENT MODE ADJUSTMENTS .....	5 - 5
<b>SECTION 6</b>	<b>PARTS LIST</b>	
<b>SECTION 7</b>	<b>MECHANICAL PARTS AND DISASSEMBLY</b>	
<b>SECTION 8</b>	<b>SEMI-CONDUCTOR INFORMATION</b>	
<b>SECTION 9</b>	<b>BOARD LAYOUTS</b>	
9 - 1	LOGIC UNIT .....	9 - 1
9 - 2	RF UNIT.....	9 - 3
9 - 3	AF UNIT / VCO UNIT .....	9 - 5
<b>SECTION 10</b>	<b>BLOCK DIAGRAM</b>	
<b>SECTION 11</b>	<b>VOLTAGE DIAGRAM</b>	

# SECTION 1 SPECIFICATIONS

## ■ GENERAL

- Frequency range :

(Unit: MHz)

Version	50 MHz	145 MHz	440 MHz	Receiving
USA	50 – 53.995	144 – 148	430 – 450* <sup>2</sup>	0.495–999.990* <sup>4</sup>
CAN		136 – 174* <sup>1</sup>	400 – 470* <sup>3</sup>	
GEN		140 – 150* <sup>1</sup>	430 – 440	
SEA				

\*<sup>1</sup>Specifications guaranteed 144 – 148 MHz

\*<sup>2</sup>Specifications guaranteed 440 – 450 MHz

\*<sup>3</sup>Specifications guaranteed 430 – 440 MHz

\*<sup>4</sup>Except 824 – 849 MHz, 869 – 894 MHz [USA] only

- Mode : FM, AM (RX only) and WFM (Rx only)
- Number of memory channels : 555 (incl. 50 scan edges and 5 call channels)
- Frequency stability :  $\pm 6$  ppm max. ( $-10^{\circ}\text{C}$  to  $+60^{\circ}\text{C}$ ;  $14^{\circ}\text{F}$  to  $140^{\circ}\text{F}$ )
- Tuning steps : 5, 6.25, 8.33, 9, 10, 12.5, 15, 20, 25, 30, 50 100, and 200 kHz
- Usable temperature range :  $-10^{\circ}\text{C}$  to  $+60^{\circ}\text{C}$ ;  $14^{\circ}\text{F}$  to  $140^{\circ}\text{F}$
- Power supply requirement : 5.5 – 11 V DC or specified battery pack
- Usable battery pack/case : BP-217 (7.4 V) and BP-216 (3.2 V)
- Polarity : Negative ground
- Current drain (at 8.0 V DC) : (typical value)

		50/145 MHz	440 MHz
TX	High power	2.0 A	2.0 A
	Low power	0.8 A	1.2 A
RX	Rated output	220 mA	
	Standby	100 mA	
	Power saved* <sup>1</sup>	65 mA	

\*<sup>1</sup>Power save duty is 1:4.

- Antenna connector : SMA (50  $\Omega$ )
- Dimensions (projections not included) : 58(W)  $\times$  87(H)  $\times$  29(D) mm; 2<sup>17</sup>/<sub>32</sub>(W)  $\times$  3<sup>7</sup>/<sub>16</sub>(H)  $\times$  1<sup>5</sup>/<sub>32</sub>(D) in
- Weight (with BP-217/Ant.) : 280 g; 9<sup>7</sup>/<sub>8</sub> oz

## ■ TRANSMITTER

- Output power (at 8.0 V DC) : High 5.0 W typical  
Low 0.5 W typical
- Modulation system : Variable reactance modulation
- Max. freq. deviation :  $\pm 5$  kHz
- Spurious Emissions : Less than  $-60$  dB
- External MIC connector : 3-conductor 2.5(d) mm ( $1/8''$ ); 2 k $\Omega$

## RECEIVER

- Receiver system : Double-conversion superheterodyne
- Intermediate frequency : 1st 13.350 MHz (FM/AM)  
13.350 MHz (WFM)  
2nd 450 kHz

- Sensitivity\*1: (except spurious points; typical values)

Frequency (MHz)	FM	AM	WFM
0.495–1.625	–	1.3 $\mu$ V	–
1.625–4.995	0.4 $\mu$ V		
5.000–29.995	0.18 $\mu$ V	0.56 $\mu$ V	1.0 $\mu$ V*4
29.995–49.995		–	
50.000–54.000	0.16 $\mu$ V		
54.005–76.000	0.18 $\mu$ V	–	
76.000–108.000			
108.000–118.000	0.18 $\mu$ V	0.5 $\mu$ V	–
118.000–136.000			
136.000–143.995	0.16 $\mu$ V	–	–
144.000–148.000			
148.005–175.000	0.4 $\mu$ V	–	1.8 $\mu$ V
175.000–221.995			
222.000–225.000	0.32 $\mu$ V	0.79 $\mu$ V*2	–
225.005–246.995	0.4 $\mu$ V		
247.000–329.995	0.32 $\mu$ V	1.0 $\mu$ V*3	
329.995–429.995			
430.000–450.000	0.16 $\mu$ V	–	3.2 $\mu$ V
450.005–470.000	0.32 $\mu$ V		
470.000–770.000		0.32 $\mu$ V	–
770.000–832.995			
833.000–999.990	1.0 $\mu$ V	–	–

\*1 FM and WFM are measured at 12 dB SINAD, AM is measured at 10 dB S/N.

\*2 The frequency range is between 222.000 MHz and 229.995 MHz.

\*3 The frequency range is between 320.000 MHz and 329.995 MHz.

\*4 The frequency range is between 40.000 MHz and 108.000 MHz.

- Selectivity
  - AM and FM : Less than 15 kHz/–9 dB  
More than 30 kHz/–60 dB
  - WFM : Less than 350 kHz/–3 dB  
More than 700 kHz/–20 dB
- Spurious and image rejection ratio
  - 50 MHz More than 60 dB  
IF/2: More than 50 dB  
IF: More than 40 dB
  - 145 MHz More than 60 dB  
IF/2: More than 50 dB
  - 440 MHz More than 50 dB  
IF: More than 60 dB
- Audio output power : 200 mW typical at 10 % distortion with an 8  $\Omega$  load

- AF output impedance : 8  $\Omega$
- Squelch sensitivity\*1: (typical; Except spurious points)

Frequency (MHz)	FM	AM	WFM
0.495–1.625	–	1.3 $\mu$ V	–
1.625–4.995	0.4 $\mu$ V		
5.000–29.995	0.18 $\mu$ V	0.56 $\mu$ V	1.0 $\mu$ V*4
29.995–49.995		–	
50.000–54.000	0.16 $\mu$ V		
54.005–76.000	0.18 $\mu$ V	–	
76.000–108.000			
108.000–118.000	0.18 $\mu$ V	0.5 $\mu$ V	–
118.000–136.000			
136.000–143.995	0.16 $\mu$ V	–	–
144.000–148.000			
148.005–175.000	0.4 $\mu$ V	–	1.8 $\mu$ V
175.000–221.995			
222.000–225.000	0.32 $\mu$ V	0.79 $\mu$ V*2	–
225.005–246.995	0.4 $\mu$ V		
247.000–329.995	0.32 $\mu$ V	1.0 $\mu$ V*3	
329.995–429.995			
430.000–450.000	0.16 $\mu$ V	–	3.2 $\mu$ V
450.005–470.000	0.32 $\mu$ V		
470.000–770.000		0.32 $\mu$ V	–
770.000–832.995			
833.000–1319.995	1.0 $\mu$ V	–	–

\*1 FM and WFM are measured at 12 dB SINAD, AM is measured at 10 dB S/N.

\*2 The frequency range is between 222.000 MHz and 229.995 MHz.

\*3 The frequency range is between 320.000 MHz and 330.000 MHz.

\*4 The frequency range is between 40.000 MHz and 108.000 MHz.

All stated specifications are subject to change without notice or obligation.

## SECTION 2 INSIDE VIEWS

### • LOGIC UNIT

Top view

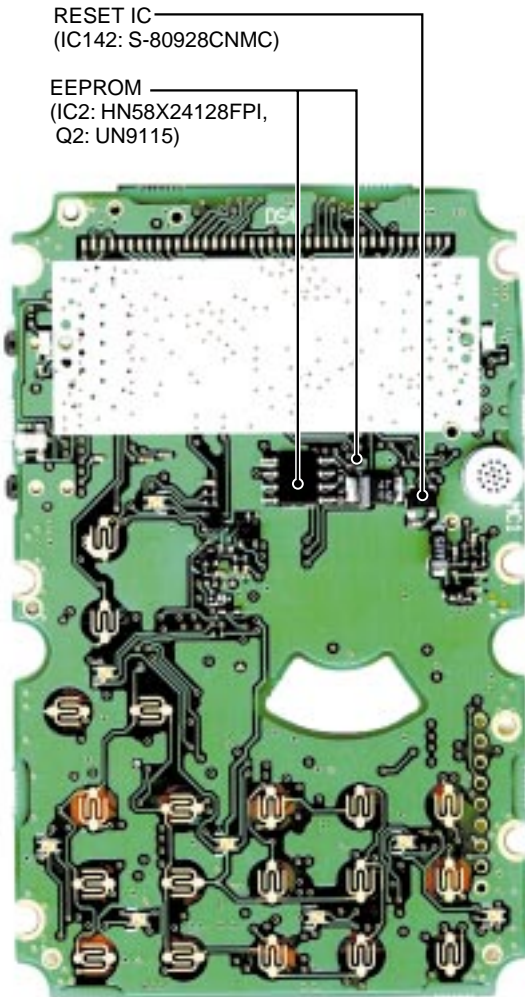

### • LOGIC UNIT

Bottom view

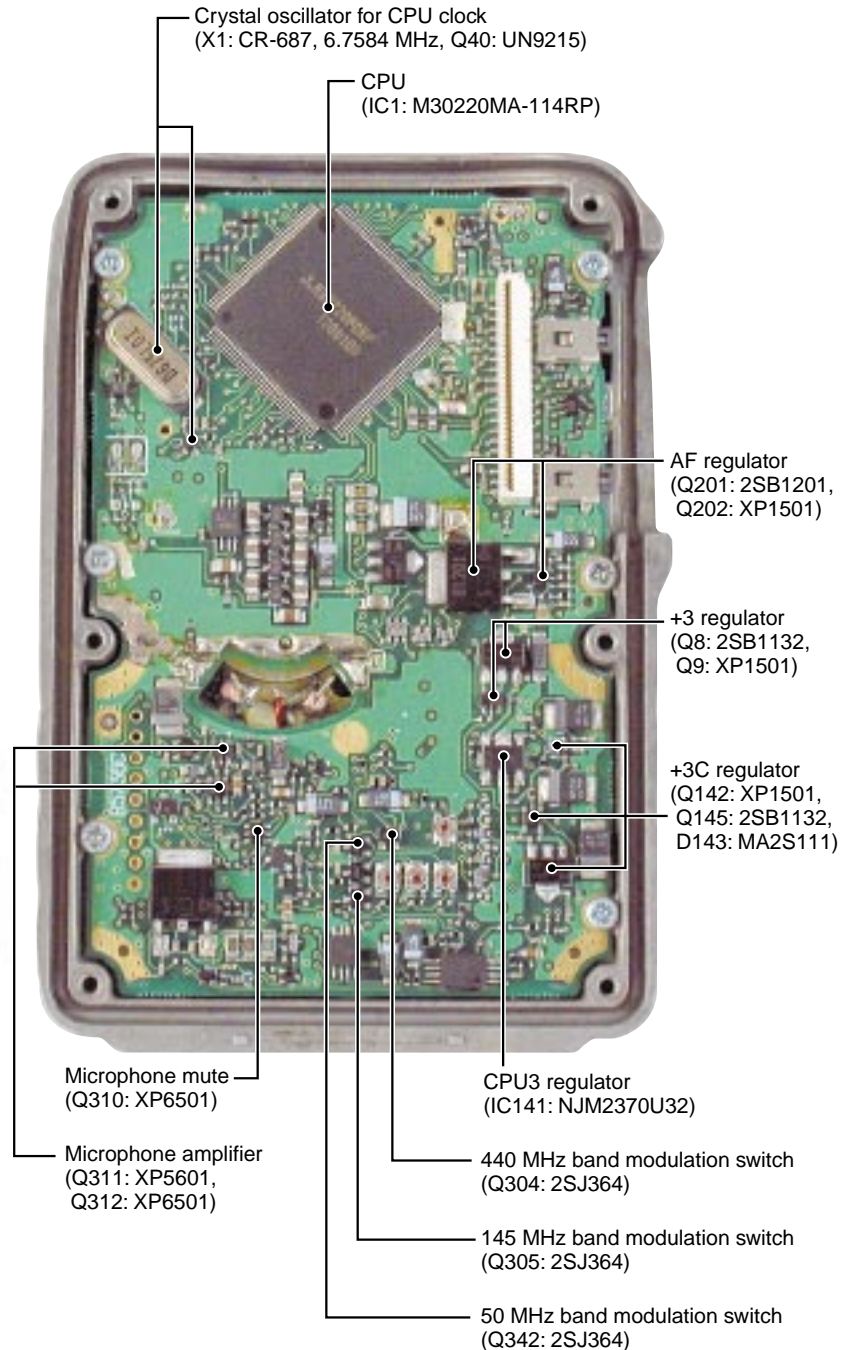

• **AF UNIT**

Top view

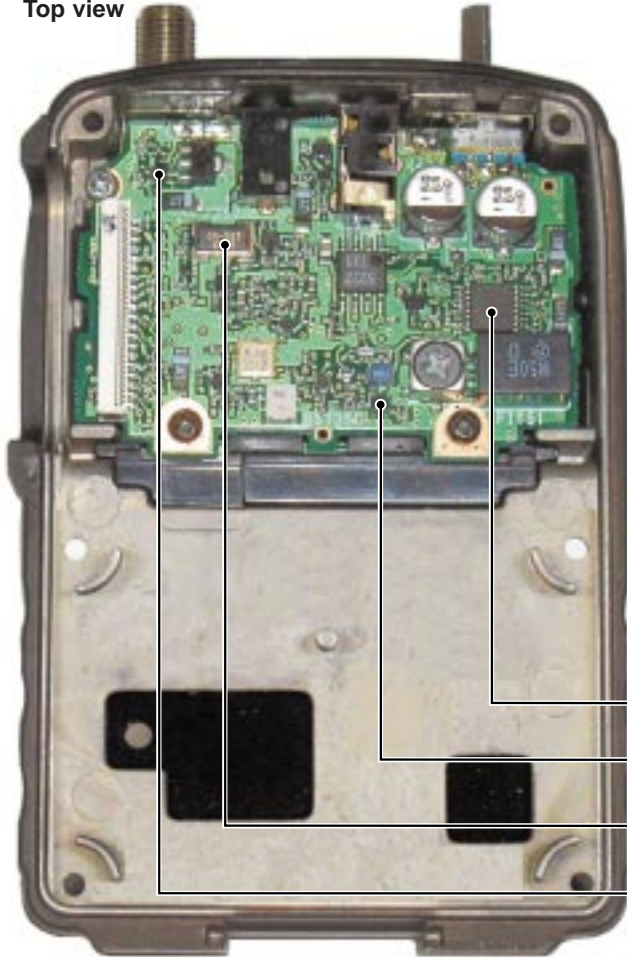

• **AF UNIT**

Bottom view

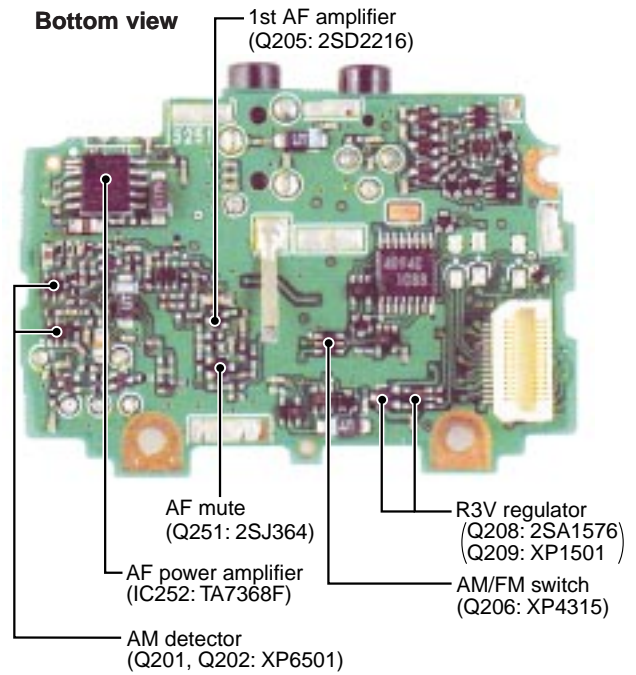

- 1st AF amplifier (Q205: 2SD2216)
- AF mute (Q251: 2SJ364)
- AF power amplifier (IC252: TA7368F)
- AM detector (Q201, Q202: XP6501)
- R3V regulator (Q208: 2SA1576) (Q209: XP1501)
- AM/FM switch (Q206: XP4315)
- FM IF IC (IC151: TA31136FN)
- IF amplifier (Q102: 2SC4403)
- Crystal oscillator (X1: VR-583, 13.800 MHz)
- T5V regulator (Q11: XP1501, Q55: 2SB1132)

• **RF UNIT**

Top view

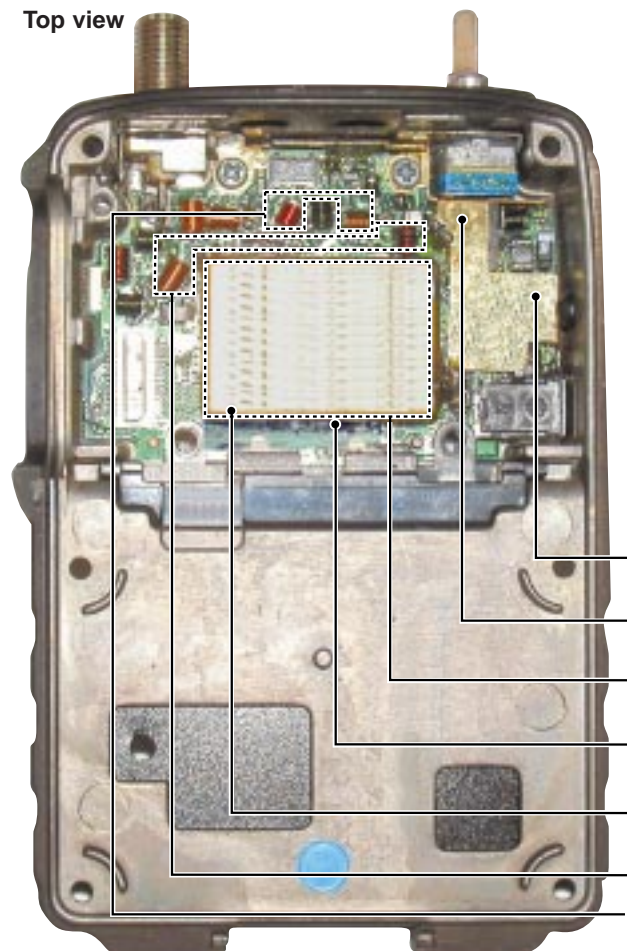

• **RF UNIT**

Bottom view

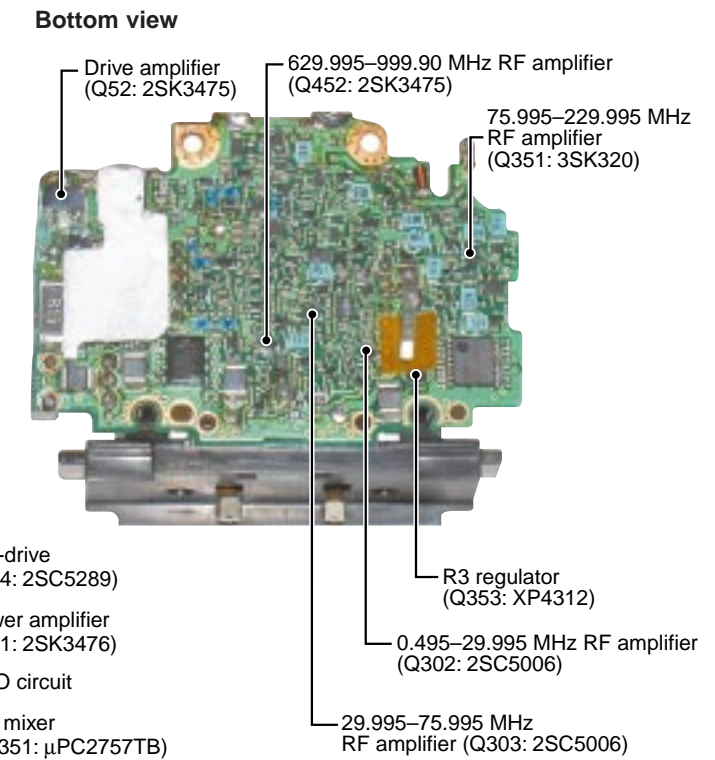

- Drive amplifier (Q52: 2SK3475)
- 629.995-999.90 MHz RF amplifier (Q452: 2SK3475)
- 75.995-229.995 MHz RF amplifier (Q351: 3SK320)
- R3 regulator (Q353: XP4312)
- 0.495-29.995 MHz RF amplifier (Q302: 2SC5006)
- 29.995-75.995 MHz RF amplifier (Q303: 2SC5006)
- Pre-drive (Q54: 2SC5289)
- Power amplifier (Q51: 2SK3476)
- VCO circuit
- 1st mixer (IC351:  $\mu$ PC2757TB)
- T3 regulator (Q56: XP4315, D50: MA6S121)
- 144 MHz TX high-pass filter circuit
- 50 MHz TX low-pass filter circuit

## SECTION 3 DISASSEMBLY INSTRUCTIONS

### 1. Removing the rear panel

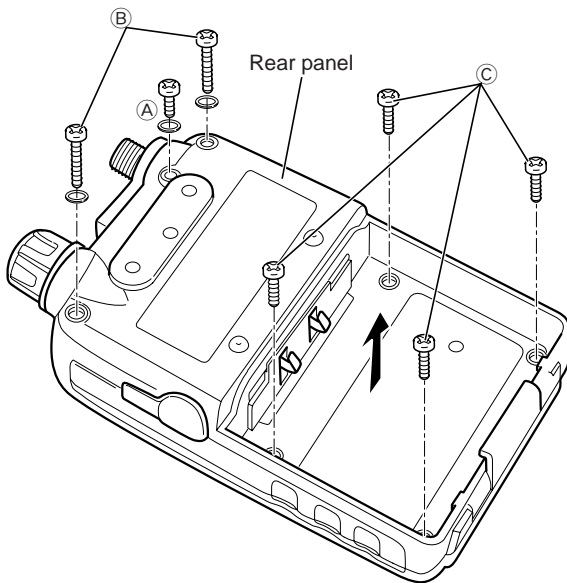

- ① Unscrew 1 screw **A** (M2 × 4 mm, black).
- ② Unscrew 2 screws **B** (M2 × 20 mm, black), and 4 screws **C** (M2 × 6 mm, black) from the rear panel.
- ③ Take off the rear panel in the direction of the arrow.

### 2. Removing the LOGIC unit

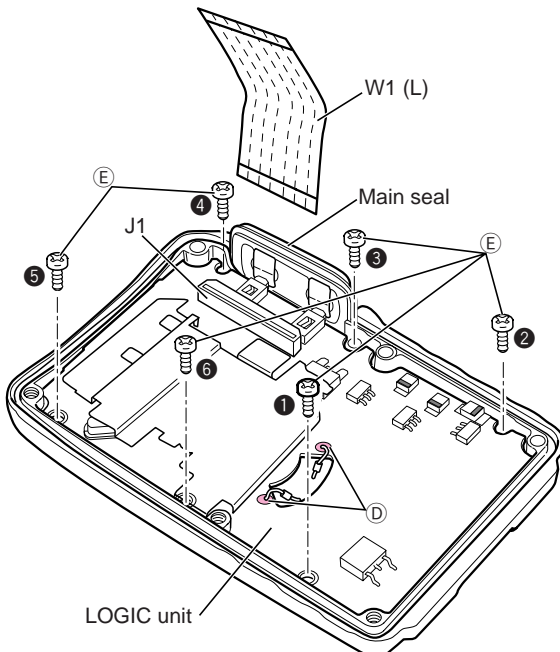

- ① Unplug the flexible cable W1 from J1 on the LOGIC unit to separate the rear panel.
- ② Take off the main seal.
- ③ Unsolder 2 points **D** at the speaker lead.
- ④ Unscrew 6 screws **E** (2 × 4 mm, silver) to separate the LOGIC unit.

#### NOTE:

When you tighten 6 screws **E**, tighten those in turn of **1-6**.

### 3. Removing the AF unit

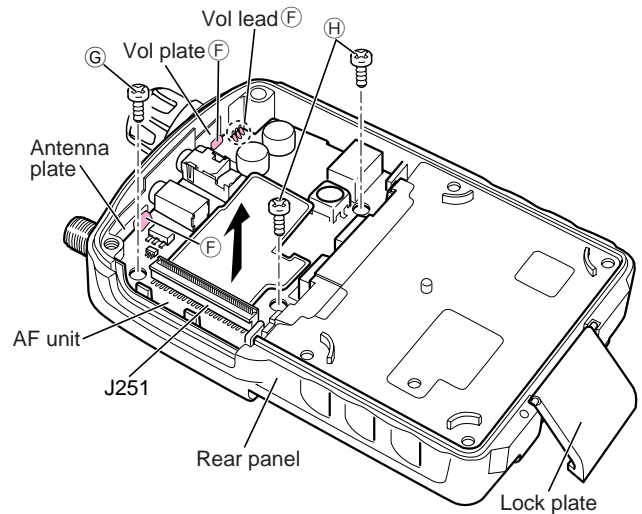

- ① Take off the lock plate.
- ② Unsolder 5 points **F** at the antenna plate, vol plate and lead.
- ③ Unscrew 1 screw **G** (2 × 4 mm, silver), and 2 screws **H** (M2 × 12 mm, black) from the AF unit.
- ④ Take off the AF unit in the direction of the arrow to separate the rear panel.

### 4. Removing the RF unit

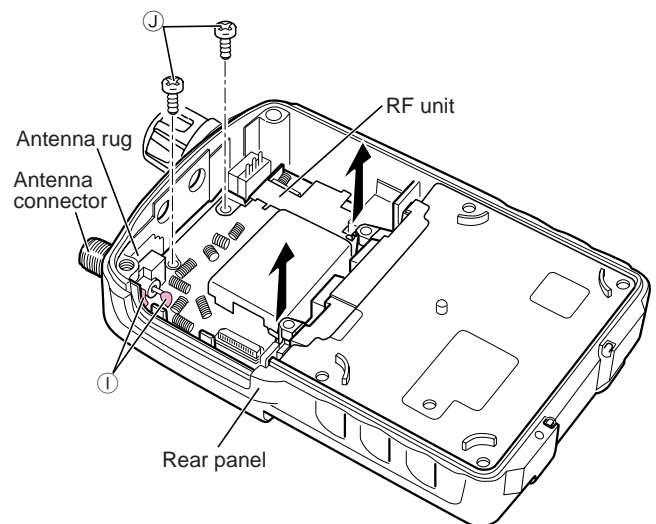

- ① Unsolder 2 points **I** at the antenna rug plate and antenna connector.
- ② Unscrew 2 screws **J** (M2 × 4 mm, silver) from the FRONT panel.
- ③ Take off the RF unit in the direction of the arrow to separate the rear panel.



# SECTION 4 CIRCUIT DESCRIPTION

## 4-1 RECEIVER CIRCUITS

### 4-1-1 TRIPLEXER CIRCUIT (RF UNIT)

The transceiver has a triplexer (low-pass and bandpass filters) on the first stage from the antenna switching diode to separate the signals.

- **RF signals 0.495 MHz–75.995 MHz**

The 0.495 MHz–75.995 MHz RF signals are passed through the low-pass filters (L5, L6, L24, C43, C483–C486, L11–L13, L17–L19, C21, C481, C482) and are applied to the antenna switching circuit.

- **RF signals 76.0 MHz–299.995 MHz**

The 76.0 MHz–299.995 MHz RF signals are passed through the low-pass (L5, L6, L24, C43, C483–C486) and high-pass (L9, C9–C11) filters and are applied to the antenna switching circuit.

- **RF signals 230.0 MHz–629.995 MHz**

The 230.0 MHz–629.995 MHz RF signals are passed through the high-pass (L1, C1–C3) and low-pass (F11) filters and are applied to the antenna switching circuit.

- **RF signals 630.0 MHz–999.990 MHz**

The 630.0 MHz–999.990 MHz RF signals are passed through the high-pass (L3, L4, C6–C8) filter and are applied to the RF circuit.

### 4-1-2 ANTENNA SWITCHING CIRCUIT (RF UNIT)

The antenna switching circuit functions as a low-pass filter while receiving. However, its impedance becomes very high while transmitting by applying a current to D4, D6, D9, D12, D13, D19.

Thus, transmit signals are blocked from the entering the receiver circuits. The antenna switching circuit employs a  $1/4\lambda$  type diode switching system. The signals are applied to the each antenna switching circuit.

- **RF signals 0.495 MHz–75.995 MHz**

The signals pass through the antenna switching circuit (D9), and then applied to the RF circuit.

- **RF signals 76.0 MHz–299.995 MHz**

The signals pass through the antenna switching circuit (D8), and then applied to the RF circuit.

- **RF signals 230.0.0 MHz–629.995 MHz**

The signals pass through the antenna switching circuit (D7), and then applied to the RF circuit.

### 4-1-3 RF CIRCUIT (RF UNIT)

The RF circuit amplifies the received signals within the range of frequency coverage and filters out-of-band signals.

#### (1) 0.495 MHz–29.995 MHz RF CIRCUIT

The signals from the antenna switching circuit pass through the attenuator (D305) and band switch (D301). The signals applied to the bandpass filter (L301, L302, C301–C307) to suppress unwanted signals, then amplified at the RF amplifier (Q302).

#### (2) 30.0 MHz–75.995 MHz RF CIRCUIT

The signals from the antenna switching circuit pass through the attenuator (D305) and band switch (D306). The signals applied to the bandpass filter (D307, D308, L303, L304, C317–C320) to suppress unwanted signals, then pass through the bandpass filter (D309, D310, L306, L307, L323–C325, C331) after being amplified at the RF amplifier (Q303).

- **TRIPLEXER AND ANTENNA SWITCHING CIRCUITS**

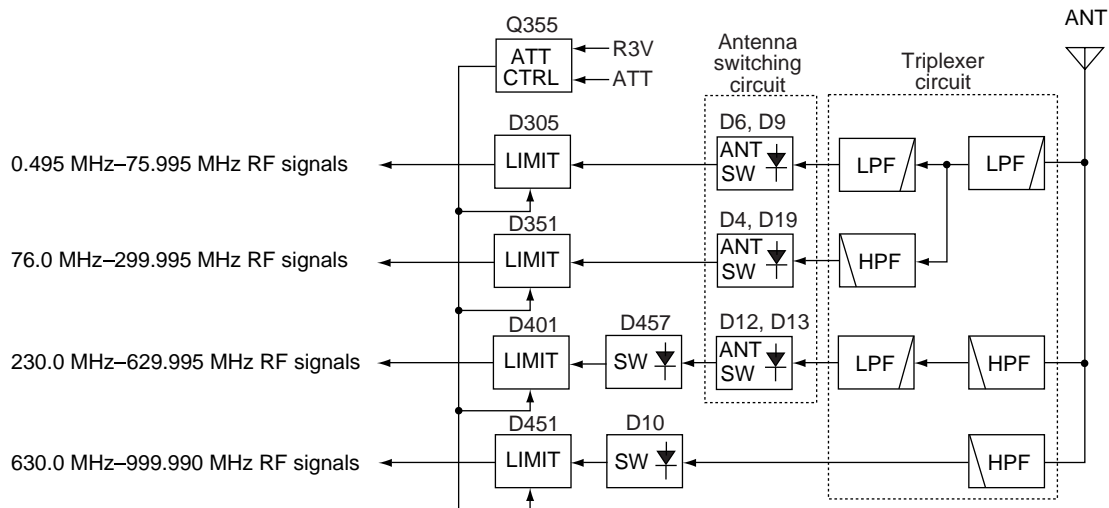

**(3) 76.0 MHz–229.995 MHz RF CIRCUIT**

The signals from the antenna switching circuit pass through the attenuator (D351), and then applied to the bandpass filter (D352, D353, L351, L352) to suppress unwanted signals. The signals pass through the bandpass filter (D354–D356, D359, L354, L355, L357, L358, C357–C364) after being amplified at the RF amplifier (Q351).

**(4) 230.0 MHz–629.995 MHz RF CIRCUIT**

The signals from the antenna switching circuit are applied to the band switch (D457), and then pass through the attenuator (D401). The signals pass through the bandpass filter (D402, D403, L401, L402, C402, C404–C406) to suppress unwanted signals, then applied to the RF amplifier (Q401). The amplified signals pass through the bandpass filter (D405, D407, L409, C414, C415), and are then amplified at the RF amplifier (Q402).

**(5) 630.0 MHz–999.990 MHz RF CIRCUIT**

The signals from the antenna pass through the high-pass filter (L3, L4, C6–C8), and then applied to the attenuator (D451) after being passed through the band switch (D10). The signals pass through the bandpass filter (D452, L451, C451–C454), then applied to the RF amplifier (Q451). The amplified signals pass through the bandpass filter (D453, D454, L452, L453, C456, C460, C462–C464) and RF amplifier (Q452).

The amplified or filtered signals pass through one of the band switch (D303, D313, D358, D408, D455), and then applied to the 1st mixer circuit (IC351, pin 1).

**4-1-4 1ST MIXER AND 1ST IF CIRCUITS (RF, AF AND VCO UNITS)**

The 1st mixer circuit converts the received RF signals to a fixed frequency of the 1st IF signal with a PLL output frequency. By changing the PLL frequency, only the desired frequency will pass through the bandpass filter at the next stage of the 1st mixer.

The amplified or filtered RF signals are mixed with 1st LO signals at the 1st mixer (IC351) to produce a 69.45 MHz 1st IF signal. The 1st IF signal is output from pin 6, and passed through the bandpass filter (Narrow: AF unit; FI101, Wide: AF unit; FI102) to suppress unwanted harmonic components via the mode switch (AF unit; D101, D102). The filtered 1st IF signal is applied to the IF amplifier (AF unit; Q102). The amplified signal is applied to the 2nd mixer circuit.

The 1st LO signals (53.350 MHz–99.345 MHz, 99.350 MHz–560.545 MHz or 281.675 MHz–534.720 MHz) are generated at the 144 MHz VCO (VCO unit; Q3–Q5, D3, D4) or 430 MHz VCO (VCO unit; Q1, Q2, D1) circuits. The oscillated signal is applied to the 1st mixer via the doubler circuit (Q354, D357) or directly.

**4-1-5 2ND IF AND DEMODULATOR CIRCUITS (AF UNIT)**

The 2nd mixer circuit converts the 1st IF signal to a 2nd IF signal. A double conversion superheterodyne system (which converts receive signals twice) improves the image rejection ratio and obtain stable receiver gain.

The FM IF IC (IC151) contains 2nd local oscillator, 2nd mixer, limiter amplifier, quadrature detector and S-meter detector circuits.

The amplified 69.45 MHz 1st IF signal from the IF amplifier (Q102) is mixed with the 2nd LO signal at the 2nd mixer (IC151) to produce a 455 kHz 2nd IF signal. The 2nd IF signal from the IC151, pin 3 passes through (AM and FM mode) or bypasses (WFM mode) the 2nd IF filter (FI151) where unwanted heterodyne signals are suppressed via the mode switch (D151, D152). The filtered signals are applied to the AM detector circuit or FM detector circuit respectively.

**• RF CIRCUIT**

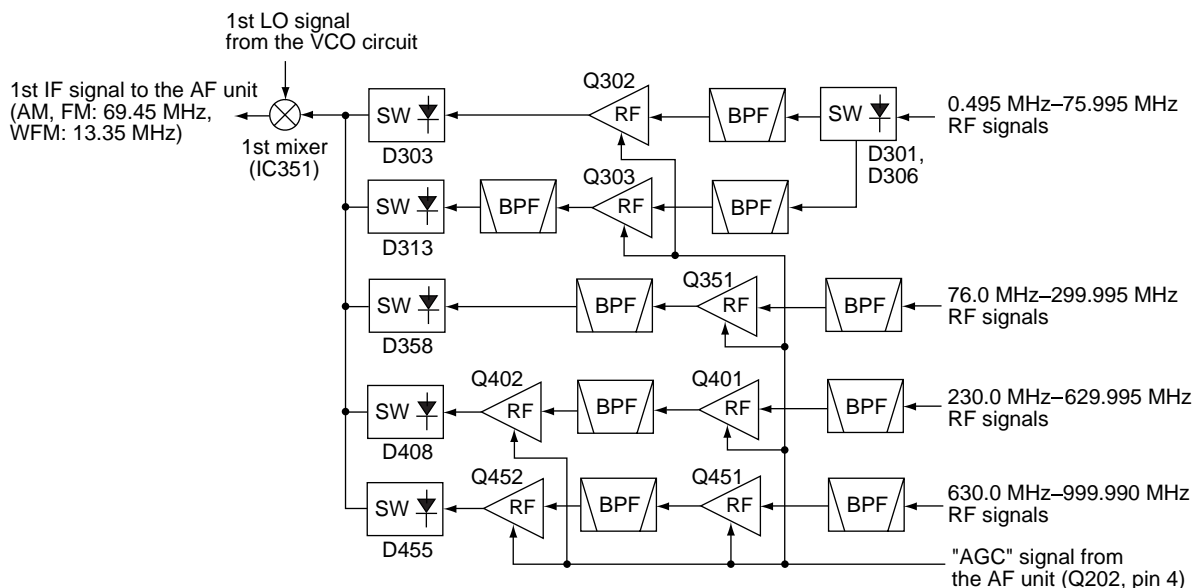

**(1) AM DETECTOR CIRCUIT**

The filtered signals are applied to the AM detector circuit (Q201, Q202) to demodulate the 2nd IF signal into the AM AF signals.

**(2) FM AND WFM DETECTOR CIRCUIT**

The filtered signals are applied to the limiter amplifier section in the FM IF IC (IC151, pin 5), and then applied to the quadrature detector section to demodulate the 2nd IF signal into FM and WFM AF signals.

The demodulated AM, FM or WFM signals are applied to the AF amplifier circuit.

**4-1-6 AF AMPLIFIER CIRCUIT (AF UNIT)**

The AF amplifier circuit which is included a low-pass filter, AF mute switch, AF volume controller and AF amplifier amplifies the demodulated AF signals to drive a speaker.

**(1) AM AND FM AF SIGNALS**

The demodulated AM or FM ("DETO" signal) AF signals from the AM detector (Q201, Q202) or FM detector (IC151, pin 9) circuits are passed through the low-pass filter (Q204) via the mode switch (D201). The filtered signals are applied to the 1st AF amplifier (Q205).

**(2) WFM AF SIGNALS**

The demodulated WFM ("DETO" signal) AF signals from FM detector (IC151, pin 9) circuit are bypassed the low-pass filter (Q204) via the mode switch (D201). The demodulated signals are applied to the 1st AF amplifier (Q205).

The amplified AF signals from the 1st AF amplifier (Q205) are applied to the AF mute switch (Q251) which is controlled by "MUTE" signal from the CPU (LOGIC unit; IC1, pin 48), and are then applied to the electronic volume control circuit (IC251, pin 6). The level controlled AF signals are output from the volume IC (LOGIC unit; IC251, pin 7) and are then applied to the AF power amplifier (IC252, pin 4). The power amplified AF signals are then applied to the internal speaker (LOGIC unit; SP1) through the "INTSP" signal via the [EXT SP] jack (J253) when no plug is connected to the jack.

The AF filter circuit (LOGIC unit; IC241, pin 5) removes AF signals below 300 Hz (CTCSS signals) for clear AF output and these are applied to the CPU (LOGIC unit; IC1, pin 7) for the CTCSS squelch detection via the "CTCIN" line.

The electronic volume control circuit controls AF gain, therefore, the AF output level is according to the [VOL] setting and also the squelch conditions.

**4-1-7 SQUELCH CIRCUIT(AF AND LOGIC UNITS)**

**• NOISE SQUELCH**

The noise squelch circuit cuts out AF signals when no RF signals are received. By detecting noise components in the AF signals, the squelch circuit switches the AF mute switch.

A portion of the AF signals from the FM IF IC (IC151, pin 9) are applied to the active filter section (IC151, pins 7, 8). The active filter section amplifies and filters noise components. The filtered signals are applied to the noise detector section and output from IC151 (pin 13) as the "NOISE" signal.

The "NOISE" signal from IC151 (pin 13) is applied to the CPU (LOGIC unit; IC1, pin 47). The CPU analyzes the noise condition and outputs the "MUTE" signal to AF mute switch (Q251).

Even when the squelch is closed, the AF mute switch (Q251) opens at the moment of emitting beep tones.

**• TONE SQUELCH**

The tone squelch circuit detects AF signals and opens the squelch only when receiving a signal containing a matching subaudible tone (CTCSS). When tone squelch is in use, and a signal with a mismatched or no subaudible tone is received, the tone squelch circuit mutes the AF signals even when noise squelch is open.

A portion of the AF signals from the FM IF IC (IC151, pin 9) passes through the low-pass filter (LOGIC unit; IC241, pins 5, 7) to remove AF (voice) signals and is applied to the CTCSS decoder inside the CPU (LOGIC unit; IC1, pin 8) via the "CTCIN" line to control the AF mute switch.

**• 2ND IF AND DEMODULATOR CIRCUIT**

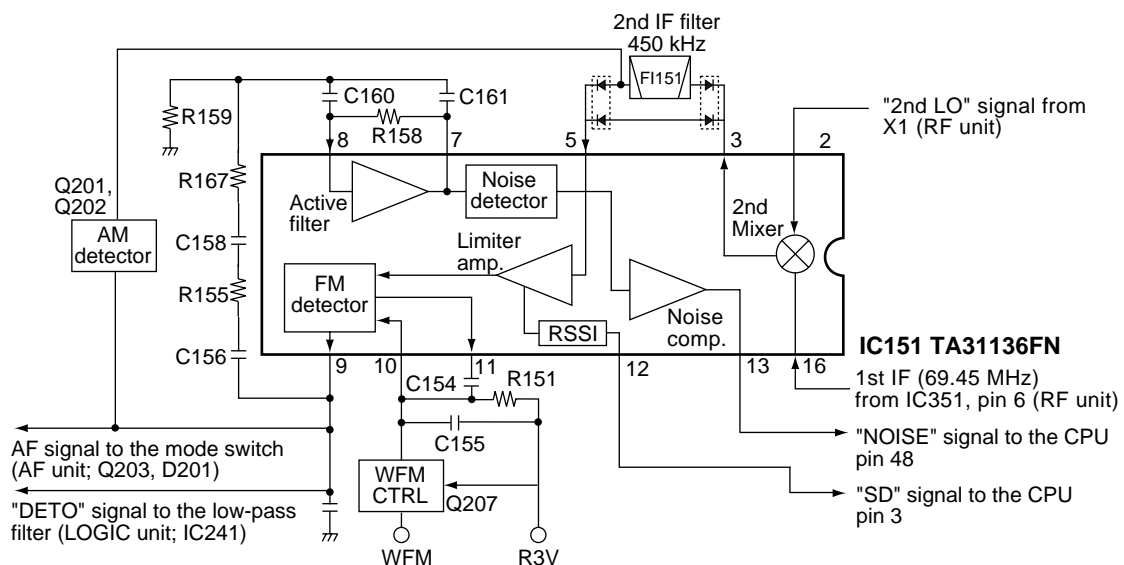

#### 4-1-8 AGC CIRCUIT (AF AND RF UNITS)

The AGC (Automatic Gain Control) circuit reduce signal fading and keeps the audio output level constant.

A portion of AF signals from the AM detector circuit (Q201) are applied to the amplifier (Q202). The amplified DC voltage from the Q202, pin 4 is applied to the RF amplifiers (RF unit; Q302, Q303, Q351, Q401, Q402, Q451, Q452) to reduce the amplifier gain when strong signals are received.

### 4-2 TRANSMITTER CIRCUITS

#### 4-2-1 MICROPHON AMPLIFIER CIRCUIT (LOGIC UNIT)

The microphone amplifier circuit amplifies the audio signals from the microphone, within +6 dB/octave pre-emphasis characteristics (300 Hz–3 kHz), to a level needed for the modulation circuit. The microphone amplifier circuit is used for both the VHF and UHF bands.

The AF signals from the microphone (MC1) or external [MIC] jack (AF unit; J252) passes through the microphone mute circuit (Q310, pins 4, 2) which is controlled by the CPU (IC1, pin 48) via the "MUTE" signal. The AF signals are applied to the microphone (limiter) amplifier (Q311, Q312) which has +6 dB/octave pre-emphasis characteristics, and are then passed through the low-pass filter (Q310, pins 4, 1). The filtered signals are applied to the modulation circuit (VCO unit) as the "VMOD" signal via the each modulation band switch (Q342, R365: for 50 MHz band, Q305, R326: for 145 MHz band, Q304, R325: for the 440 MHz band).

#### 4-2-2 MODULATION CIRCUIT (RF AND VCO UNITS)

The modulation circuit modulates the VCO oscillating signal (RF signal) using the microphone AF signals.

The signals from the modulation band switches (LOGIC unit) are then applied to the 144 MHz VCO or 430 MHz VCO circuits separately.

##### • 144 MHz VCO

The applied signals from the RF unit change the reactance of D3 to modulate the oscillated signal at the 144 MHz VCO circuit (VCO unit; Q4, Q5).

##### • 430 MHz VCO

The applied signals from the RF unit change the reactance of D1 to modulate the oscillated signal at the 430 MHz VCO circuit (VCO unit; Q1, Q2).

The modulated signal is amplified at the buffer amplifier (VCO unit; Q7) and is then bypassed divider circuit (VCO unit; IC1) via the divider switch (VCO unit; D8, D10). The signal is amplified at the two LO amplifiers (VCO unit; Q16, Q212), and then applied to the drive/power amplifier circuits.

#### 4-2-3 DRIVE/POWER AMPLIFIER CIRCUITS (RF UNIT)

The drive amplifier circuit amplifies the transmit signal to a level needed for the power amplifier circuit. The power amplifier circuit amplifies this to obtain a specified transmit output power.

The signal from the two LO amplifiers (VCO unit; Q16, Q212) is passed through the Transmit/Receive switch (Q51), and is amplified at the buffer amplifier (IC51, pin 1). The signal is applied to the pre-driver (Q54) via the attenuator (D54). The amplified signal is applied to the power amplifier via the 50 MHz line, 144 MHz and 430 MHz line separately.

##### • 50 MHz LINE

The amplified signal passes through the low-pass filter (L54, C60, C89, R81, R82) via the D57, and is then applied to the power amplifier (Q51).

##### • 144 MHz AND 430 MHz LINE

The amplified signal passes through the high-pass filter (L56, C65, C68, C69), and is then applied to the drive amplifier (Q52). The signal is applied to the power amplifier (Q51).

The amplified signal is applied to the each TX filter circuit.

#### 4-2-4 TX FILTER CIRCUIT (RF UNIT)

The amplified signal from the drive/power amplified circuit is passed through the each TX filter circuit to suppress high-harmonics spurious components

##### (1) 50 MHz TX FILTER CIRCUIT

The amplified 50 MHz signal from the power amplifier passes through the low-pass filter (L22, L23, C34, C44, C480) and  $1/4\lambda$  type antenna switch (D6). The filtered signal is applied to the low-pass filter (L11–L13, L17–L19, C21, C481, C482) again, and is then passed through the triplexer circuit (L5, L6, L24, C43, C483, C486).

##### (2) 144 MHz TX FILTER CIRCUIT

The amplified 144 MHz signal from the power amplifier passes through the bandpass filter (L18, L19, C24, C26, C27) and  $1/4\lambda$  type antenna switch (D4, D19). The filtered signal is applied to the high-pass filter (L9, C9–C11), and is then passed through the triplexer circuit (L5, L6, L24, C43, C483–C486).

##### (3) 430 MHz TX FILTER CIRCUIT

The amplified 430 MHz signal from the power amplifier passes through the high-pass filter (L16, L456, C32, C33, C98) and  $1/4\lambda$  type antenna switch (D2, D18). The filtered signal is applied to the low-pass filter (F11), and is then passed through the triplexer circuit (L1, C1–C3).

The filtered signal is applied to the antenna connector (CHASSIS unit; J1).

Collector voltage for the drive amplifier (Q52) and control voltage for the power amplifier (Q51) are controlled by the APC circuit to protect the power module from a mismatched condition as well as to stabilize the output power.

### 4-2-5 APC CIRCUIT (RF UNIT)

The APC circuit protects the power amplifier from a mismatched output load and stabilizes the output power. The APC circuit is designed to use VHF and UHF bands commonly.

The APC sensor (R109) detects driving current from the drive voltage at the drive (Q52) and power (Q51) amplifiers. The detected current is converted into DC voltage at Q101, then applied to the APC control circuit (IC101, pin 2). The applied voltage is compared with a "PSET" voltage from the CPU via the D/A convertor (IC251), and the APC control circuit outputs control voltage from pin 1 to control the drive and power amplifiers.

When the driving current is increased, input voltage of the differential amplifier (IC101, pin 2) will be increased. In such cases, the differential amplifier output voltage (IC101, pin 1) is decreased to reduce the driving current.

### 4-3 PLL CIRCUITS

#### 4-3-1 GENERAL

A PLL circuit provides stable oscillation of the transmit frequency and the receive local frequency. The PLL circuit compares the phase of the divided VCO frequency to the reference frequency. The PLL output frequency is controlled by the divided ratio (N-data) of a programmable divider.

#### 4-3-2 144 MHz AND 430 MHz VCO CIRCUITS (VCO UNIT)

##### • 144 MHz VCO CIRCUIT

The oscillated signal at the 144 MHz VCO circuit (Q1–Q3, D1, D2) is amplified at two buffer amplifiers (Q7, Q11), and is then applied to the PLL IC (IC201, pin 19). The signal is divided by serial data from the CPU (LOGIC unit; IC1) and phase detected with the divided reference frequency (5 kHz). The phase difference is output from pin 5 as pulses.

#### • APC CIRCUIT

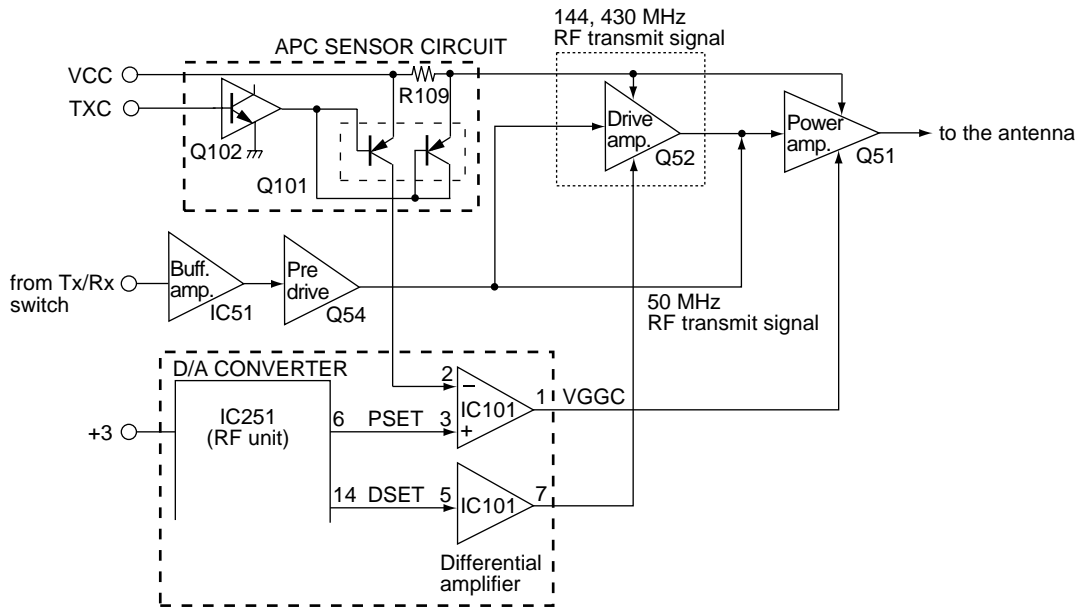

**• 430 MHz VCO CIRCUIT**

The oscillated signal at the 430 MHz VCO circuit (Q4, Q5, D3) is amplified at two buffer amplifiers (Q7, Q11), and is then applied to the PLL IC (IC201, pin 19). The signal is divided by serial data from the CPU (LOGIC unit; IC1) and phase-detected with the divided reference frequency (5 kHz). The phase difference is output from pin 5 as pulses.

The output signals from the PLL IC (IC201, pin 5) are converted to DC voltages (lock voltage) by the loop filter, and are then fed back to the 144 MHz and 430 MHz VCO circuits to stabilize the VCO frequency.

**4-3-3 VCO DIVIDER CIRCUIT (VCO AND RF UNITS)**

The PLL circuit employs the two VCO circuits (144 MHz and 430 MHz) and VCO divider (IC1) to transmit on 3 bands and receive wide band.

The oscillated signal at the 144 MHz or 430 MHz VCO circuit is amplified at the buffer amplifier (Q7), and is then passed through the divider switch (D7, D8).

When the signal is applied to the divider circuit (IC1, pin 2), the circuit divides the VCO signal into the ratio of 1/2. The divided signal passes through the low-pass filter (L12, L13, C48–C51) and divider switch (D9).

When the signal bypasses the divider circuit (IC1), it passes through the divider switch (D8, D10).

The VCO signal is applied to the LO amplifiers (Q16, Q212), and then passed through the transmit/receive switch (D21, D202). The signal is applied to the buffer amplifier (RF unit; IC51, pin 1) for the TX LO frequency, or applied to the 1st mixer circuit (IC351, pin 3) for the RX 1st LO frequency as “LO” signal via or bypass the doubler circuit (Q354).

**• PLL CIRCUIT**

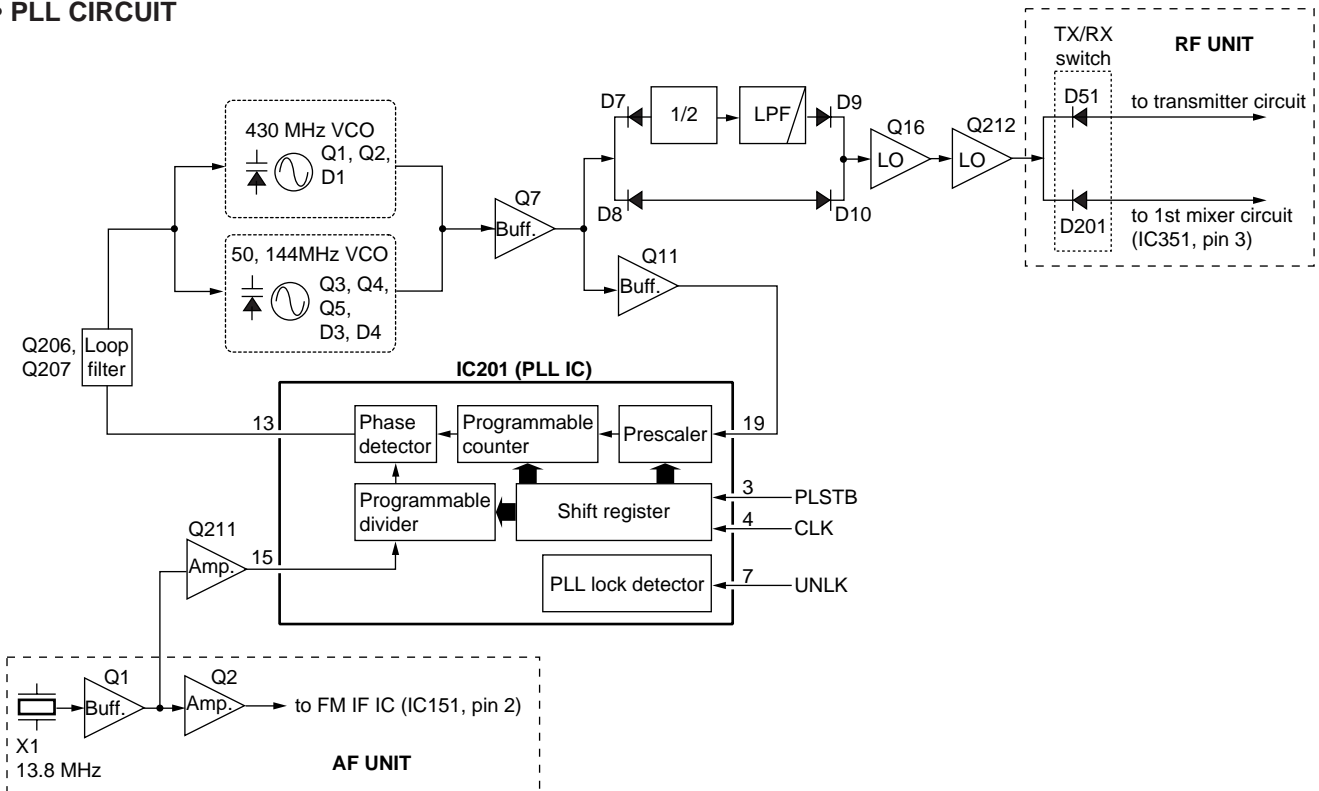

## 4-4 POWER SUPPLY CIRCUITS

### VOLTAGE LINE

LINE	DESCRIPTION
HV	The voltage from the external power supply or attached battery pack.
VCC	The same voltage as the "HV" line (external power supply or battery pack).
CPU3	Common 3 V converted from the "VCC" line by CPU3 regulator IC (LOGIC unit; IC141). The output voltage is supplied to the +3C regulator circuits, etc.
+3C	Common 3 V converted from the "VCC" line by the +3C regulator circuit (LOGIC unit; Q142 and Q145) using the +3CPU regulator (LOGIC unit; IC141.)
+3	Common 3 V converted from the "VCC" line by the +3 regulator circuit (LOGIC unit; Q8 and Q9) using the +3C regulator (LOGIC unit; Q142 and Q145).
+10V	Common 10 V converted from the "+3" line by the +10 regulator circuit (LOGIC unit; IC91, IC92, Q91, D91, D300–D302). The output voltage is applied to the RF and VCO units.
AFV	6 V for receiver circuit converted from the "VCC" line by the "AF" regulator circuit (LOGIC unit; Q201, Q202). The output voltage is applied to the AF amplifier (AF unit; IC252, pin 2).
R3	3 V for receiver circuit converted from the "+3" line by the "R3" regulator circuit (RF unit; O353).
R3V	3 V for the receiver circuit converted from the "VCC" line by the "R3V" regulator circuit (AF unit; Q208 and Q209).
T3	3 V for transmitter circuit converted from the "+3" line by the "T3" regulator circuit (RF unit; Q56 and D20). The output voltage is applied to the buffer amplifier (RF unit; IC51, pin 6).

## 4-5 PORT ALLOCATIONS

### 4-5-1 D/A CONVERTOR IC (RF UNIT; IC251)

Pin number	Port name	Description
5	FSET	Outputs frequency setting D/A data to the reference oscillator (RF unit; X1).
6	PSET	Outputs the power amplifier's output power setting data to the APC controller (RF unit; IC101).
11	TUNE	Outputs D/A data to the tuned band-pass filters (RF unit).
12	RXC	Outputs the R3 regulator (RF unit; Q353) control signal. High: While receiving.
13	ATT	Outputs attenuator control signal. Low: Attenuator is ON.
14	DSET	Outputs the drive amplifier's output power setting data to the APC controller (RF unit; IC101).

### 4-5-2 R3V SWITCH IC (AF UNIT; IC51)

Pin number	Port name	Description
4	BSFT	Outputs frequency shift control signal to tuned bandpass filters (RF unit).
5	B1C	Outputs 0.5–29.995 MHz band control signal. Low: While 0.5–29.995 MHz band is receiving.
6	B2C	Outputs 30–75.995 MHz band control signal. Low: While 30–75.995 MHz band is receiving.
7	B3	Outputs 76–229.995 MHz band control signal. Low: While 76–229.995 MHz band is receiving.
14	B4C	Outputs 230–629.995 MHz band control signal. Low: While 230–629.995 MHz band is receiving.
15	B5	Outputs 630–999.995 MHz band control signal. Low: While 630–999.995 MHz band is receiving.

#### 4-5-3 CPU (LOGIC UNIT; IC1)

Pin number	Port name	Description
1	PATMP	Input port for the PA's temperature while transmitting.
3	SD	Input port for the S-meter signal.
5	CHG	Input port for the battery voltage divide signal.
6	VIN	Input port for the power supply voltage divide signal.
7	CTCIN	Input port for the CTCSS decoded signal (67.0–254.1 Hz analog signal).
12	WFM	Outputs the FM or WFM regulator control signal. Low: FM or WFM mode is selected.
13	AM	Outputs the AM mode regulator control signal. Low: AM mode is selected.
14	CLSFT	Outputs the clock shift control signal.
19	RESET	Input port for the CPU reset signal. High: The CPU is reset.
25	POWER	Input port for the [POWER] switch. Low: Power is ON.
26	CPUHV	Input port for the external power supply connecting signal. Low: While the external power supply is connected.
28	IOSTB	Outputs the expander IC (AF unit; IC51, pin 1) strobe signal.
29	DASTB	Outputs strobe signals to the D/A IC (RF unit; IC251, pin 2).
30	CLIN	Input port for the cloning signal.
31	CLOUT	Output port for the cloning signal.
33	PDAUL	I/O port for the PLL IC (VCO unit; IC201, pin 7) data signal. Low: PLL is unlocked. High: PLL is locked.
34	CK	Outputs clock signals to the R3V switch (AF unit; IC51, pin 3), D/A IC (RF unit; IC251, pin 3) and PLL IC (VCO unit; IC201, pin 4).
35	PLSTB	Outputs the PLL IC strobe signal.
40	ECK	Outputs the EEPROM clock signal.
42	CHGC	Outputs the battery charger control signal.
43	PCON	Outputs the +3C regulator control signal.
44	R3C	Outputs the R3C regulator control signal. Low: While receiving.
45	TXC	Outputs the T5V regulator control signal. High: While transmitting.

Pin number	Port name	Description
46	MICC	Outputs the mic amplifier regulator control signal.
47	NOISE	Input port for the SQL detection noise signal.
48	MUTE	Outputs mute control signal. High: AF muting while receiving. MIC muting while transmitting.
49	AFON	Output AF amplifier regulator control signal.
51	BUSYL	Outputs BUSY LED control signal. High: The BUSY LED is ON.
52	GLED	Outputs key backlight control signal. High: Green backlight is ON.
53	RLED	Outputs key backlight control signal. High: Red backlight is ON.
54	LCDL	Outputs LCD backlight control signal. Low: Lights ON.
55	V3C	Outputs the 430 MHz VCO regulator control signal. Low: 430 MHz is selected.
56 57	DIUD DICK	Input port for the up/down signal from the main dial (AF unit; S251).
58–61	KS3–KS0	Output ports for key matrix.
62–65	I3–I0	Output ports for Initial matrix.
66–69	KR3–KR1	Input ports for key matrix.
70	V1C	Outputs the 50 MHz VCO regulator control signal. Low: 50 MHz is selected.
71	VOLDN	Input port for the volume level control signal. Low: Volume level is low.
72	VOLUP	Input port for the volume level control signal. Low: Volume level is high.
73	SQL	Input port for the [SQL] switch. Low: While [SQL] switch is pushed.
74	430M	Outputs the 430 MHz modulation circuit control signal. Low: While 430 MHz is transmitting.
75	144M	Outputs the 144 MHz modulation circuit control signal. Low: While 144 MHz is transmitting.
77	PTT	Input port for the [PTT] switch. High: While [PTT] switch is pushed.
81	V2C	Outputs 144 MHz VCO regulator control signal. Low: 144 MHz is selected.
82	VSFT	Outputs the VCO select signal.



#### 4-5-3 CPU (Continued)

Pin number	Port name	Description
84	50M	Outputs the 50 MHz modulation circuit control signal. Low: While 50 MHz is transmitting.
85	CTSEL	Outputs the CT3 switch (LOGIC unit; Q301) control signal. Low: DTCS/CTCSS is selected.
86	DTCS	Outputs the DTCS decoder filter control signal.
88–90	SEG37–SEG35	Output segment data to the LCD (LOGIC unit; DS4, pins 5–7).
92	SEG34	Outputs segment data to the LCD (LOGIC unit; DS4, pin 8).
94–96	SEG33–SEG31	Output segment data to the LCD (LOGIC unit; DS4, pins 9–11).
97 98	CONT1 CONT0	Output the LCD contrast control signals.
99–127	SEG28–SEG0	Output segment data to the LCD (LOGIC unit; DS4, pins 12–40).
128–131	COM3–COM0	Output common data to the LCD (LOGIC unit; DS4, pins 1–4).
138	VOLC	Outputs the volume IC (AF unit; IC251, pin 5) control signal.
139	CTCOUT	Outputs CTCSS/DTCS signals.
141	BEEP	Output beep, DTMF tone, 1750 Hz tone sounds.
144	WXALT	Input port for the WX alert signal.

# SECTION 5 ADJUSTMENT PROCEDURES

## 5-1 PREPARATION

Some adjustments must be adjusted on the adjustment mode. When entering the adjustment mode, the 68 kΩ terminator (shown at page 5-2) is required.

### ■ REQUIRED TEST EQUIPMENT

EQUIPMENT	GRADE AND RANGE	EQUIPMENT	GRADE AND RANGE
DC power supply	Output voltage : 11 V DC	Ammeter	Measuring capacity : 10 A and 30 A
	Current capacity : 3 A or more	DC voltmeter	Input impedance : 50 kΩ/V DC or better
RF power meter (terminated type)	Measuring range : 1–10 W	Audio generator	Frequency range : 300–3000 Hz Measuring range : 1–500 mV
	Frequency range : 28–600 MHz	Standard signal generator (SSG)	Frequency range : 1–1300 MHz Output level : 0.1 μV–32 mV (–127 to –17 dBm)
	Impedance : 50 Ω		Oscilloscope
SWR : Less than 1.2 : 1	Attenuator	Power attenuation : 40 or 50 dB	
Frequency counter	Frequency range : 0.1–600 MHz Frequency accuracy : ±1 ppm or better Sensitivity : 100 mV or better		
FM deviation meter	Frequency range : 30–600 MHz Measuring range : 0 to ±10 kHz		

### ■ ENTERING THE ADJUSTMENT MODE

- ① Connect a 68 kΩ terminator to the [SP] jack.
- ② Push and hold the [SQL] and [8] keys, and then turn power ON.

### ■ OPERATION ON THE ADJUSTMENT MODE

- Change the adjustment value : [DIAL]
- Change the adjustment channel or item [UP] : [VFO] key
- Change the adjustment channel or item [DOWN] : [MR] key
- Verify the setting condition : [8] key

### ■ OPERATION ON THE “OUTPUT POWER” ADJUSTMENT

When adjusting the “OUTPUT POWER” adjustment, need to change the adjustment channel indicator manually.

When displayed channel indicator “DH” on the LCD at first, push the “0” or “.” keys to change the channel indicator as follow.

Pushing key	LCD (Before)	LCD (After)
“0” key	DH	PH
“0” key	PH	DH

Pushing key	LCD (Before)	LCD (After)
“.” key	DH	DL
“.” key	DL	DE
“.” key	DE	DH

• CONNECTION

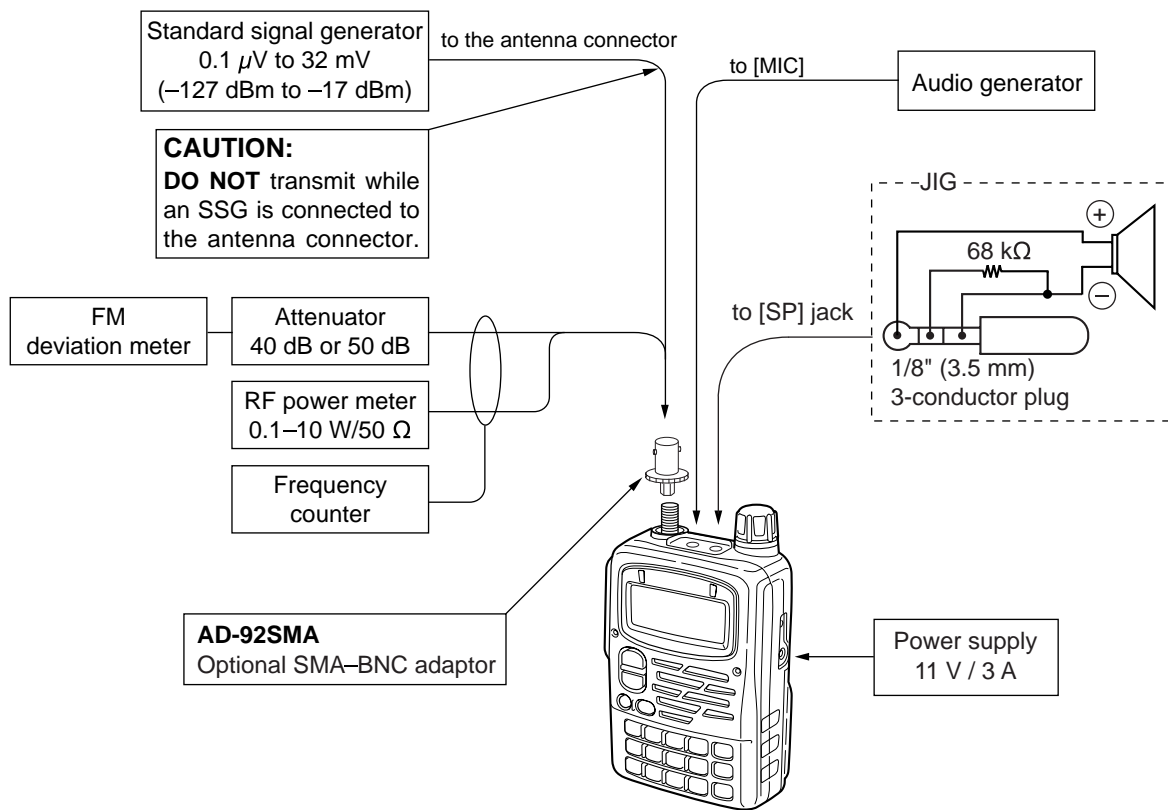

## 5-2 TRIMMER ADJUSTMENT

The following adjustment must be performed on the normal mode.

ADJUSTMENT	ADJUSTMENT CONDITION	MEASUREMENT		VALUE	ADJUSTMENT POINT			
		UNIT	LOCATION		UNIT	ADJUST		
PLL LOCK VOLTAGE	1	<ul style="list-style-type: none"> <li>• Displayed frequency : 30.000 MHz</li> <li>• Mode : FM</li> <li>• Receiving</li> </ul>	VCO	Connect the DC voltmeter or an oscilloscope to the checkpoint "CP".	0.4 V–1.0 V		Verify	
	2	<ul style="list-style-type: none"> <li>• Displayed frequency : 29.995 MHz</li> <li>• Mode : FM</li> <li>• Receiving</li> </ul>					7.0 V–11.0 V	Verify
	3	<ul style="list-style-type: none"> <li>• Displayed frequency : 150.000 MHz</li> <li>• Mode : WFM</li> <li>• Receiving</li> </ul>					0.7 V–2.0 V	verify
	4	<ul style="list-style-type: none"> <li>• Displayed frequency : 169.995 MHz</li> <li>• Mode : WFM</li> <li>• Receiving</li> </ul>					7.0 V–11.0 V	Verify
	5	<ul style="list-style-type: none"> <li>• Displayed frequency : 550.000 MHz</li> <li>• Mode : WFM</li> <li>• Receiving</li> </ul>					0.6 V–1.2 V	Verify
	6	<ul style="list-style-type: none"> <li>• Displayed frequency : 629.990 MHz</li> <li>• Mode : FM</li> <li>• Receiving</li> </ul>					7.0 V–11.0 V	Verify
POWER BALANCE	1	<ul style="list-style-type: none"> <li>• Displayed frequency : 144.000 MHz</li> <li>• Transmitting</li> </ul>	Top panel	Connect an RF power meter to the antenna connector.	144.000 MHz's power	RF	L19	
	2	<ul style="list-style-type: none"> <li>• Displayed frequency : 148.000 MHz</li> <li>• Transmitting</li> </ul>					Same value as 144.000 MHz's power	L19
	3	<ul style="list-style-type: none"> <li>• Displayed frequency : 440.000 MHz</li> <li>• Transmitting</li> </ul>					440.000 MHz's power	L16, L456
	4	<ul style="list-style-type: none"> <li>• Displayed frequency : 460.000 MHz</li> <li>• Transmitting</li> </ul>					Same value as 440.000 MHz's power	L16, L456
	5	• Same adjustments as steps 1–4 several times.						

• VCO UNIT

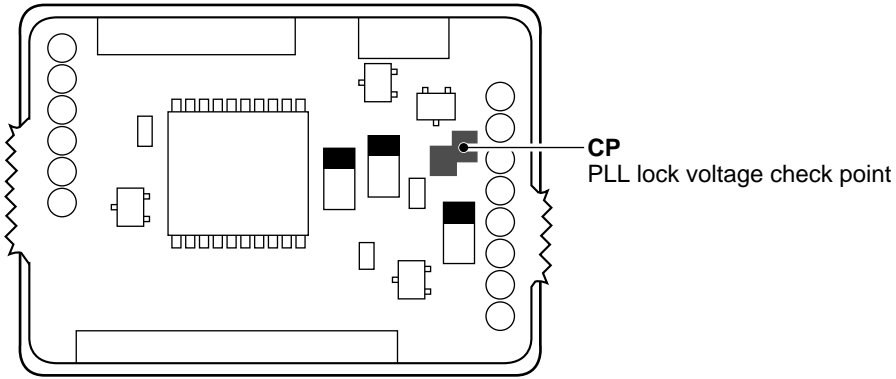

• RF UNIT

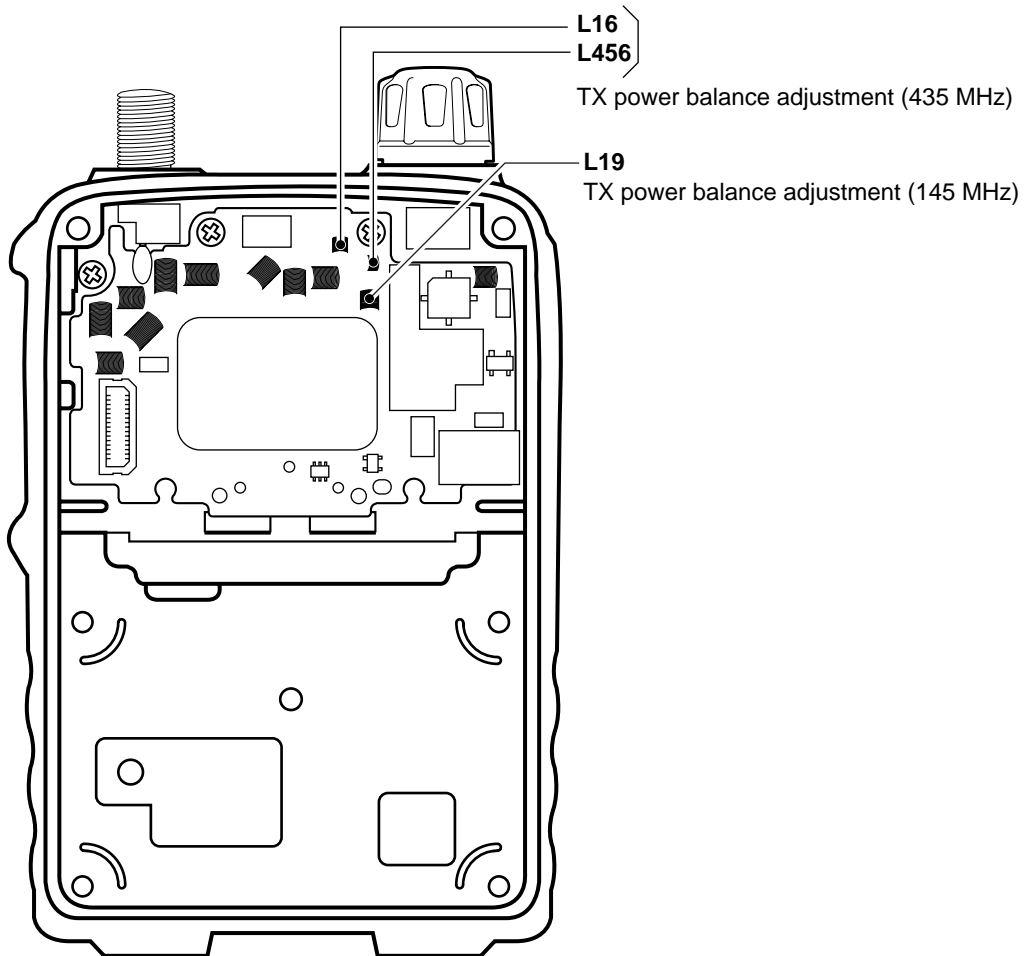

### 5-3 ADJUSTMENT MODE ADJUSTMENTS

The following adjustment must be performed at "ADJUSTMENT MODE".

ADJUSTMENT	ADJUSTMENT CONDITION	MEASUREMENT		VALUE	ADJUSTMENT POINT	
		UNIT	LOCATION		UNIT	ADJUST
REFERENCE FREQUENCY	1 • Displayed frequency : (Fr ch.) 445.000 MHz • Output power : Low • Transmitting	Top panel	Loosely couple the frequency counter to the antenna connector.	445.0000 MHz	Top panel	[DIAL]
OUTPUT POWER (11V 50 MHz High power)	1 • Displayed frequency : (PH ch.) 50.000 MHz • Output power : High • Transmitting	Top panel	Connect an RF power meter to the [ANT] connector.	5.0 W	Top panel	[DIAL]
	2 • Displayed frequency : (PH ch.) 53.900 MHz • Transmitting			5.0 W		[DIAL]
(11V 145 MHz High power)	3 • Displayed frequency : (PH ch.) 144.000 MHz • Output power : High • Transmitting	Top panel	Connect an RF power meter to the [ANT] connector.	5.0 W	Top panel	[DIAL]
	4 • Displayed frequency : (PH ch.) 148.000 MHz • Transmitting			5.0 W		[DIAL]
(11V 440 MHz High power)	5 • Displayed frequency : (PH ch.) 440.000 MHz • Output power : High • Transmitting	Top panel	Connect an RF power meter to the [ANT] connector.	5.0 W	Top panel	[DIAL]
	6 • Displayed frequency : (PH ch.) 450.000 MHz • Transmitting			5.0 W		[DIAL]
(11V 50 MHz Low power)	7 • Displayed frequency : (PH ch.) 50.000 MHz • Output power : Low • Transmitting	Top panel	Connect an RF power meter to the [ANT] connector.	0.5 W	Top panel	[DIAL]
	8 • Displayed frequency : (PH ch.) 53.900 MHz • Transmitting			0.5 W		[DIAL]
(11V 145 MHz Low power)	9 • Displayed frequency : (PH ch.) 144.000 MHz • Output power : Low • Transmitting	Top panel	Connect an RF power meter to the [ANT] connector.	0.5 W	Top panel	[DIAL]
	10 • Displayed frequency : (PH ch.) 148.000 MHz • Transmitting			0.5 W		[DIAL]

## ADJUSTMENT MODE ADJUSTMENTS (Continued)

- The following adjustment must be performed at "ADJUSTMENT MODE".
- The adjustment channel indicators (PL, DL, PH, DH, PE, DE) need to change from "DH" channel indicator to use "0" or "." keys.

ADJUSTMENT	ADJUSTMENT CONDITION	MEASUREMENT		VALUE	ADJUSTMENT POINT		
		UNIT	LOCATION		UNIT	ADJUST	
OUTPUT POWER (11 V 440 MHz Low power)	11	<ul style="list-style-type: none"> <li>• Displayed frequency : (DH ch.) 440.000 MHz</li> <li>• Output power : Low</li> <li>• Transmitting</li> </ul>	Front panel	LCD display	DH = "00"	Top panel	[DIAL]
	12	<ul style="list-style-type: none"> <li>• Set the channel indicator : "PH"</li> <li>• Transmitting</li> </ul>	Side panel	Connect an ammeter between a power supply and the transceiver.	1.1 A		[DIAL]
	13	<ul style="list-style-type: none"> <li>• Set the channel indicator : "DH"</li> <li>• Transmitting</li> </ul>	Top panel	Connect an RF power meter to the [ANT] connector.	0.5 W		[DIAL]
	14	<ul style="list-style-type: none"> <li>• Displayed frequency : (DH ch.) 450.000 MHz</li> <li>• Output power : Low</li> <li>• Transmitting</li> </ul>	Front panel	LCD display	DH = "00"		[DIAL]
	15	<ul style="list-style-type: none"> <li>• Set the channel indicator : "PH"</li> <li>• Transmitting</li> </ul>	Side panel	Connect an ammeter between a power supply and the transceiver.	1.1 A		[DIAL]
	16	<ul style="list-style-type: none"> <li>• Set the channel indicator : "DH"</li> <li>• Transmitting</li> </ul>	Top panel	Connect an RF power meter to the [ANT] connector.	0.5 W		[DIAL]
OUTPUT POWER (8V 50 MHz High power)	1	<ul style="list-style-type: none"> <li>• Displayed frequency : (PL ch.) 50.000 MHz</li> <li>• Output power : High</li> <li>• Transmitting</li> </ul>	Top panel	Connect an RF power meter to the [ANT] connector.	5.0 W	Top panel	[DIAL]
	2	<ul style="list-style-type: none"> <li>• Displayed frequency : (PL ch.) 53.900 MHz</li> <li>• Transmitting</li> </ul>			5.0 W		[DIAL]
(8V 144 MHz High power)	3	<ul style="list-style-type: none"> <li>• Displayed frequency : (PL ch.) 144.000 MHz</li> <li>• Output power : High</li> <li>• Transmitting</li> </ul>	Top panel	Connect an RF power meter to the [ANT] connector.	5.0 W	Top panel	[DIAL]
	4	<ul style="list-style-type: none"> <li>• Displayed frequency : (PL ch.) 148.000 MHz</li> <li>• Transmitting</li> </ul>			5.0 W		[DIAL]
(8V 440 MHz High power)	5	<ul style="list-style-type: none"> <li>• Displayed frequency : (PL ch.) 440.000 MHz</li> <li>• Output power : High</li> <li>• Transmitting</li> </ul>	Top panel	Connect an RF power meter to the [ANT] connector.	5.0 W	Top panel	[DIAL]
	6	<ul style="list-style-type: none"> <li>• Displayed frequency : (PL ch.) 450.000 MHz</li> <li>• Transmitting</li> </ul>			5.0 W		[DIAL]

## ADJUSTMENT MODE ADJUSTMENTS (Continued)

- The following adjustment must be performed at "ADJUSTMENT MODE".
- The adjustment channel indicators (PL, DL, PH, DH, PE, DE) need to change from "DH" channel indicator to use "0" or "." keys.

ADJUSTMENT	ADJUSTMENT CONDITION	MEASUREMENT		VALUE	ADJUSTMENT POINT	
		UNIT	LOCATION		UNIT	ADJUST
OUTPUT POWER (8V 50 MHz Low power)	7 • Displayed frequency : (PH ch.) 50.000 MHz • Output power : Low • Transmitting	Top panel	Connect an RF power meter to the [ANT] connector.	0.5 W	Top panel	[DIAL]
	8 • Displayed frequency : (PH ch.) 53.900 MHz • Transmitting					[DIAL]
(8V 145 MHz Low power)	9 • Displayed frequency : (PH ch.) 144.000 MHz • Output power : Low • Transmitting	Top panel	Connect an RF power meter to the [ANT] connector.	0.5 W	Top panel	[DIAL]
	10 • Displayed frequency : (PH ch.) 148.000 MHz • Transmitting					[DIAL]
(8V 440 MHz Low power)	11 • Displayed frequency : (DL ch.) 440.000 MHz • Output power : Low • Transmitting	Front panel	LCD display	DL = "00"	Top panel	[DIAL]
	12 • Set the channel indicator : "PL" • Transmitting	Side panel	Connect an ammeter between a power supply and the transceiver.	1.1 A		[DIAL]
	13 • Set the channel indicator : "DL" • Transmitting	Top panel	Connect an RF power meter to the [ANT] connector.	0.5 W		[DIAL]
	14 • Displayed frequency : (DL ch.) 450.000 MHz • Output power : Low • Transmitting	Front panel	LCD display	DL = "00"		[DIAL]
	15 • Set the channel indicator : "PL" • Transmitting	Side panel	Connect an ammeter between a power supply and the transceiver.	1.1 A		[DIAL]
	16 • Set the channel indicator : "DL" • Transmitting	Top panel	Connect an RF power meter to the [ANT] connector.	0.5 W		[DIAL]



## ADJUSTMENT MODE ADJUSTMENTS (Continued)

- The following adjustment must be performed at "ADJUSTMENT MODE".
- The adjustment channel indicators (PL, DL, PH, DH, PE, DE) need to change from "DH" channel indicator to use "0" or "." keys.

ADJUSTMENT	ADJUSTMENT CONDITION	MEASUREMENT		VALUE	ADJUSTMENT POINT		
		UNIT	LOCATION		UNIT	ADJUST	
OUTPUT POWER (5V 50 MHz)	1 • Displayed frequency : (PE ch.) 50.000 MHz • Output power : Low • Transmitting	Side panel	Connect an ammeter between a power supply and the transceiver.	0.45 A	Top panel	[DIAL]	
	2 • Displayed frequency : (PE ch.) 53.900 MHz • Transmitting					[DIAL]	
(5V 145 MHz)	3 • Displayed frequency : (DE ch.) 144.000 MHz • Output power : Low • Transmitting	Front panel	LCD display	DE = "00"	Top panel	[DIAL]	
	4 • Set the channel indicator : "PE" • transmitting	Side panel	Connect an ammeter between a power supply and the transceiver.	0.40 A		[DIAL]	
	5 • Set the channel indicator : "DE" • Transmitting			0.45 A	[DIAL]		
	6 • Displayed frequency : (DE ch.) 148.000 MHz • Output power : Low • Transmitting	Front panel	LCD display	DE = "00"	Top panel	[DIAL]	
	7 • Set the channel indicator : "PE" • transmitting	Side panel	Connect an ammeter between a power supply and the transceiver.	0.40 A		[DIAL]	
	8 • Set the channel indicator : "DE" • Transmitting			0.45 A		[DIAL]	
	(5V 440 MHz)	9 • Displayed frequency : (DE ch.) 440.000 MHz • Output power : Low • Transmitting	Front panel	LCD display		DE = "00"	Top panel
		10 • Set the channel indicator : "PE" • transmitting	Side panel	Connect an ammeter between a power supply and the transceiver.	0.35 A	[DIAL]	
11 • Set the channel indicator : "DE" • Transmitting		Front panel	LCD display	DE = "60"	Top panel	[DIAL]	
12 • Displayed frequency : (DE ch.) 450.000 MHz • Output power : Low • Transmitting		Front panel	LCD display	DE = "00"		[DIAL]	
13 • Set the channel indicator : "PE" • transmitting		Side panel	Connect an ammeter between a power supply and the transceiver.	0.35 A		[DIAL]	
14 • Set the channel indicator : "DE" • Transmitting		Front panel	LCD display	DE = "60"		[DIAL]	

## ADJUSTMENT MODE ADJUSTMENTS (Continued)

• The following adjustment must be performed at "ADJUSTMENT MODE".

ADJUSTMENT	ADJUSTMENT CONDITION	MEASUREMENT		VALUE	ADJUSTMENT POINT	
		UNIT	LOCATION		UNIT	ADJUST
FM DEVIATION (50 MHz)	1 • Displayed frequency : (DH ch.) 53.900 MHz • Connect a audio generator to the [MIC] jack and set as: 1 kHz/90 mVrms • Set an FM deviation meter as: HPF : OFF LPF : 20 kHz De-emphasis : OFF Detector : (p-p)/2 • Output power : High • Transmitting	Top Panel	Connect an FM deviation meter to the [ANT] connector through an attenuator.	± 4.2 kHz	LOGIC	R365
	2 • Displayed frequency : (DH ch.) 144.000 MHz • Transmitting					R326
	3 • Displayed frequency : (DH ch.) 440.000 MHz • Transmitting					R325
DTMF DEVIATION (50 MHz)	1 • Displayed frequency : (DM ch.) 52.000 MHz • No audio applied to the [MIC] jack. • Set an FM deviation meter as: HPF : OFF LPF : 20 kHz De-emphasis : OFF Detector : (p-p)/2 • Output power : High • Transmitting	Top panel	Connect an FM deviation meter to the [ANT] connector through an attenuator.	± 3.5 kHz	Top panel	[DIAL]
	2 • Displayed frequency : (DM ch.) 144.000 MHz • Transmitting					[DIAL]
	3 • Displayed frequency : (DM ch.) 440.000 MHz • Transmitting					[DIAL]

### • LOGIC UNIT

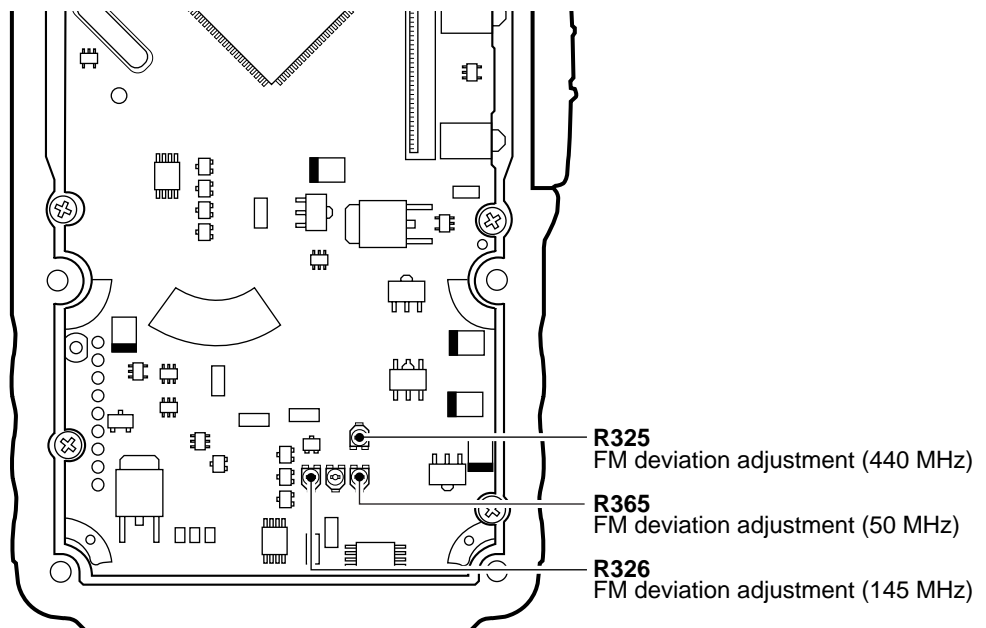

## ADJUSTMENT MODE ADJUSTMENTS (Continued)

• The following adjustment must be performed at "ADJUSTMENT MODE".

ADJUSTMENT	ADJUSTMENT CONDITION	MEASUREMENT		VALUE	ADJUSTMENT POINT				
		UNIT	LOCATION		UNIT	ADJUST			
CTCSS DEVIATION (50 MHz)	1	<ul style="list-style-type: none"> <li>• Displayed frequency : (CT ch.) 53.900 MHz</li> <li>• No audio applied to the [MIC] jack.</li> <li>• Set an FM deviation meter as:                HPF : OFF                LPF : 20 kHz                De-emphasis : OFF                Detector : (p-p)/2</li> <li>• Output power : High</li> <li>• Transmitting</li> </ul>	Top Panel	Connect an FM deviation meter to the [ANT] connector through an attenuator.	± 0.55 kHz	Top panel	[DIAL]		
	(145 MHz)	2					<ul style="list-style-type: none"> <li>• Displayed frequency : (CT ch.) 145.000 MHz</li> <li>• Transmitting</li> </ul>	± 0.55 kHz	[DIAL]
	(440 MHz)	3					<ul style="list-style-type: none"> <li>• Displayed frequency : (CT ch.) 445.500 MHz</li> <li>• Transmitting</li> </ul>	± 0.65 kHz	[DIAL]
DTCS DEVIATION (50 MHz)	1	<ul style="list-style-type: none"> <li>• Displayed frequency : (DS ch.) 51.000 MHz</li> <li>• No audio applied to the [MIC] jack.</li> <li>• Set an FM deviation meter as:                HPF : OFF                LPF : 20 kHz                De-emphasis : OFF                Detector : (p-p)/2</li> <li>• Output power : High</li> <li>• Transmitting</li> </ul>	Top panel	Connect an FM deviation meter to the [ANT] connector through an attenuator.	± 0.5 kHz	Top panel	[DIAL]		
	(145 MHz)	2					<ul style="list-style-type: none"> <li>• Displayed frequency : (DS ch.) 145.000 MHz</li> <li>• Transmitting</li> </ul>	± 0.6 kHz	[DIAL]
	(440 MHz)	3					<ul style="list-style-type: none"> <li>• Displayed frequency : (DS ch.) 445.500 MHz</li> <li>• Transmitting</li> </ul>	± 0.6 kHz	[DIAL]

## ADJUSTMENT MODE ADJUSTMENTS (Continued)

The following adjustment must be performed at "ADJUSTMENT MODE".

"DETECTOR COIL" adjustment must be performed on same channel as "DTCS DEVIATION ADJUSTMENT" (DT ch.).

ADJUSTMENT	ADJUSTMENT CONDITION	MEASUREMENT		VALUE	ADJUSTMENT POINT	
		UNIT	LOCATION		UNIT	ADJUST
DETECTOR COIL	1 <ul style="list-style-type: none"> <li>• Displayed frequency : (DS ch.) 445.000 MHz</li> <li>• Connect the SSG to the antenna connector and set as:               <ul style="list-style-type: none"> <li>Level : 1.0 <math>\mu</math>V* (-47 dBm)</li> <li>Modulation : OFF</li> </ul> </li> <li>• Receiving</li> </ul>	AF	Connect a multimeter to check point CP0.	1.0 V	AF	L151
RF TRACKING	1 <ul style="list-style-type: none"> <li>• Displayed frequency : (TL ch.) 30.100 MHz</li> <li>• Connect the SSG to the antenna connector and set as:               <ul style="list-style-type: none"> <li>Level : 0.5 <math>\mu</math>V* (-113 dBm)</li> <li>Modulation : 1 kHz</li> <li>Deviation : <math>\pm</math>3.5 kHz</li> </ul> </li> <li>• Receiving</li> </ul>	AF	Connect a DC voltmeter or oscilloscope to the IC151, pin 12 ("SD" line).	Maximum voltage	Top panel	[DIAL]
	2 <ul style="list-style-type: none"> <li>• Displayed frequency : (TH ch.) 47.100 MHz</li> <li>• Receiving</li> </ul>			Maximum voltage		[DIAL]
	3 <ul style="list-style-type: none"> <li>• Displayed frequency : (TL ch.) 48.100 MHz</li> <li>• Receiving</li> </ul>			Maximum voltage		[DIAL]
	4 <ul style="list-style-type: none"> <li>• Displayed frequency : (TH ch.) 75.100 MHz</li> <li>• Set the SSG as:               <ul style="list-style-type: none"> <li>Level : 1 <math>\mu</math>V* (-107 dBm)</li> </ul> </li> <li>• Receiving</li> </ul>			Maximum voltage		[DIAL]
	5 <ul style="list-style-type: none"> <li>• Displayed frequency : (TL ch.) 76.100 MHz</li> <li>• Set the SSG as:               <ul style="list-style-type: none"> <li>Level : 1 <math>\mu</math>V* (-107 dBm)</li> </ul> </li> <li>• Receiving</li> </ul>			Maximum voltage		[DIAL]
	6 <ul style="list-style-type: none"> <li>• Displayed frequency : (TH ch.) 149.100 MHz</li> <li>• Receiving</li> </ul>			Maximum voltage		[DIAL]
	7 <ul style="list-style-type: none"> <li>• Displayed frequency : (TL ch.) 150.100 MHz</li> <li>• Receiving</li> </ul>			Maximum voltage		[DIAL]
	8 <ul style="list-style-type: none"> <li>• Displayed frequency : (TH ch.) 229.100 MHz</li> <li>• Set the SSG as:               <ul style="list-style-type: none"> <li>Level : 3.2 <math>\mu</math>V* (-97 dBm)</li> </ul> </li> <li>• Receiving</li> </ul>			Maximum voltage		[DIAL]
	9 <ul style="list-style-type: none"> <li>• Displayed frequency : (TL ch.) 280.100 MHz</li> <li>• Receiving</li> </ul>			Maximum voltage		[DIAL]
	10 <ul style="list-style-type: none"> <li>• Displayed frequency : (TM ch.) 370.100 MHz</li> <li>• Set the SSG as:               <ul style="list-style-type: none"> <li>Level : 0.5 <math>\mu</math>V* (-113 dBm)</li> </ul> </li> <li>• Receiving</li> </ul>			Maximum voltage		[DIAL]

\*This output level of the standard signal generator (SSG) is indicated as SSG's open circuit.

• AF UNIT

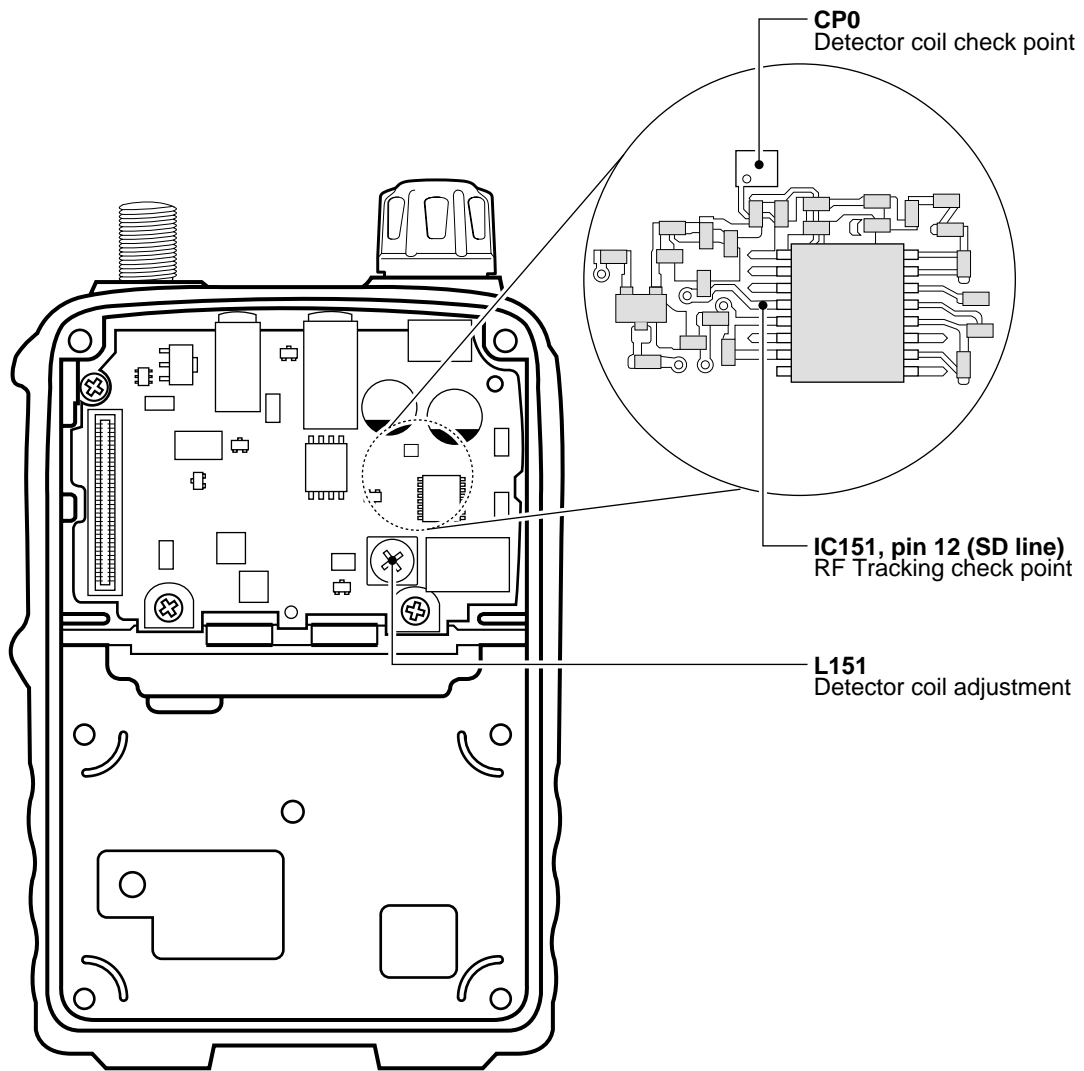

## ADJUSTMENT MODE ADJUSTMENTS (Continued)

The following adjustment must be performed at "ADJUSTMENT MODE".

ADJUSTMENT	ADJUSTMENT CONDITION	MEASUREMENT		VALUE	ADJUSTMENT POINT		
		UNIT	LOCATION		UNIT	ADJUST	
RF TRACKING	11	<ul style="list-style-type: none"> <li>• Displayed frequency : (TM ch.) 430.100 MHz</li> <li>• Connect the SSG to the antenna connector and set as:                             <ul style="list-style-type: none"> <li>Level : 0.5 <math>\mu</math>V* (-113 dBm)</li> <li>Modulation : 1 kHz</li> <li>Deviation : <math>\pm</math> 3.5 kHz</li> </ul> </li> <li>• Receiving</li> </ul>	AF	Connect a DC voltmeter or oscilloscope to the IC151, pin 12 ("SD" line).	Maximum voltage	Top panel	[DIAL]
	12	<ul style="list-style-type: none"> <li>• Displayed frequency : (TH ch.) 499.100 MHz</li> <li>• Receiving</li> </ul>			Maximum voltage		[DIAL]
	13	<ul style="list-style-type: none"> <li>• Displayed frequency : (TL ch.) 450.100 MHz</li> <li>• Receiving</li> </ul>			Maximum voltage		[DIAL]
	14	<ul style="list-style-type: none"> <li>• Displayed frequency : (TH ch.) 569.100 MHz</li> <li>• Receiving</li> </ul>			Maximum voltage		[DIAL]
	15	<ul style="list-style-type: none"> <li>• Displayed frequency : (TL ch.) 630.100 MHz</li> <li>• Set the SSG as:                             <ul style="list-style-type: none"> <li>Level : 1 <math>\mu</math>V* (-107 dBm)</li> </ul> </li> <li>• Receiving</li> </ul>			Maximum voltage		[DIAL]
	16	<ul style="list-style-type: none"> <li>• Displayed frequency : (TH ch.) 900.100 MHz</li> <li>• Set the SSG as:                             <ul style="list-style-type: none"> <li>Level : 3.2 <math>\mu</math>V* (-97 dBm)</li> </ul> </li> <li>• Receiving</li> </ul>			Maximum voltage		[DIAL]
<p><b>CONVENIENT:</b> The "RF TRACKING" can be adjusted automatically.</p> <ol style="list-style-type: none"> <li>①: Set the Displayed frequency (TL ch.) 30.100 MHz</li> <li>②: Connect the SSG to the antenna connector and set as:                             <ul style="list-style-type: none"> <li>Level : 0.5 <math>\mu</math>V* (-113 dBm)</li> <li>Modulation : 1 kHz</li> <li>Deviation : <math>\pm</math> 3.5 kHz</li> </ul> </li> <li>③: Receiving</li> <li>④: Push the [BAND] key to start tuning, automatically.</li> <li>⑤: Repeat ①-④ to perform additional frequencies.</li> </ol>							

\*This output level of the standard signal generator (SSG) is indicated as SSG's open circuit.

When adjusting by automatically, must change the SSG's level which is depended on adjustment frequencies as shown above.

## ADJUSTMENT MODE ADJUSTMENTS (Continued)

The following adjustment must be performed at "ADJUSTMENT MODE".

ADJUSTMENT	ADJUSTMENT CONDITION	OPERATION																							
S-METER	1 <ul style="list-style-type: none"> <li>• Displayed frequency : (SM ch.) 1.620 MHz</li> <li>• Mode : FM</li> <li>• Connect the SSG to the antenna connector and set as:               <ul style="list-style-type: none"> <li>Level : 0.63 <math>\mu</math>V* (-111 dBm)</li> <li>Modulation : 1 kHz</li> <li>Deviation : <math>\pm</math>3.5 kHz</li> </ul> </li> <li>• Receiving</li> </ul>	Push the [BAND] key.																							
	2 <ul style="list-style-type: none"> <li>• Same operation as step 1 for the listed frequencies and SSG level shown below.</li> <li>• Some adjustment frequencies must adjust both FM and WFM modes.</li> <li><b>When adjust the WFM mode, set the SSG's deviation as <math>\pm</math>52.5 kHz.</b></li> </ul> <table border="1"> <thead> <tr> <th>ADJUSTMENT freq.</th> <th>SSG level (FM)</th> <th>SSG level (WFM)</th> </tr> </thead> <tbody> <tr> <td>(SM Ch.) 28.100 MHz</td> <td>0.5 <math>\mu</math>V (-113 dBm)</td> <td>-</td> </tr> <tr> <td>(SM Ch.) 51.000 MHz</td> <td>0.5 <math>\mu</math>V (-113 dBm)</td> <td>1.8 <math>\mu</math>V (-102 dBm)</td> </tr> <tr> <td>(SM Ch.) 145.100 MHz</td> <td>0.5 <math>\mu</math>V (-113 dBm)</td> <td>1.8 <math>\mu</math>V (-102 dBm)</td> </tr> <tr> <td>(SM Ch.) 180.100 MHz</td> <td>0.63 <math>\mu</math>V (-111 dBm)</td> <td>3.2 <math>\mu</math>V (- 97 dBm)</td> </tr> <tr> <td>(SM Ch.) 435.100 MHz</td> <td>0.5 <math>\mu</math>V (-113 dBm)</td> <td>-</td> </tr> <tr> <td>(SM Ch.) 520.100 MHz</td> <td>0.79 <math>\mu</math>V (-109 dBm)</td> <td>3.2 <math>\mu</math>V (- 97 dBm)</td> </tr> <tr> <td>(SM Ch.) 729.100 MHz</td> <td>0.5 <math>\mu</math>V (-113 dBm)</td> <td>3.2 <math>\mu</math>V (- 97 dBm)</td> </tr> </tbody> </table>	ADJUSTMENT freq.	SSG level (FM)	SSG level (WFM)	(SM Ch.) 28.100 MHz	0.5 $\mu$ V (-113 dBm)	-	(SM Ch.) 51.000 MHz	0.5 $\mu$ V (-113 dBm)	1.8 $\mu$ V (-102 dBm)	(SM Ch.) 145.100 MHz	0.5 $\mu$ V (-113 dBm)	1.8 $\mu$ V (-102 dBm)	(SM Ch.) 180.100 MHz	0.63 $\mu$ V (-111 dBm)	3.2 $\mu$ V (- 97 dBm)	(SM Ch.) 435.100 MHz	0.5 $\mu$ V (-113 dBm)	-	(SM Ch.) 520.100 MHz	0.79 $\mu$ V (-109 dBm)	3.2 $\mu$ V (- 97 dBm)	(SM Ch.) 729.100 MHz	0.5 $\mu$ V (-113 dBm)	3.2 $\mu$ V (- 97 dBm)
ADJUSTMENT freq.	SSG level (FM)	SSG level (WFM)																							
(SM Ch.) 28.100 MHz	0.5 $\mu$ V (-113 dBm)	-																							
(SM Ch.) 51.000 MHz	0.5 $\mu$ V (-113 dBm)	1.8 $\mu$ V (-102 dBm)																							
(SM Ch.) 145.100 MHz	0.5 $\mu$ V (-113 dBm)	1.8 $\mu$ V (-102 dBm)																							
(SM Ch.) 180.100 MHz	0.63 $\mu$ V (-111 dBm)	3.2 $\mu$ V (- 97 dBm)																							
(SM Ch.) 435.100 MHz	0.5 $\mu$ V (-113 dBm)	-																							
(SM Ch.) 520.100 MHz	0.79 $\mu$ V (-109 dBm)	3.2 $\mu$ V (- 97 dBm)																							
(SM Ch.) 729.100 MHz	0.5 $\mu$ V (-113 dBm)	3.2 $\mu$ V (- 97 dBm)																							

\*This output level of the standard signal generator (SSG) is indicated as SSG's open circuit.

### • AF UNIT

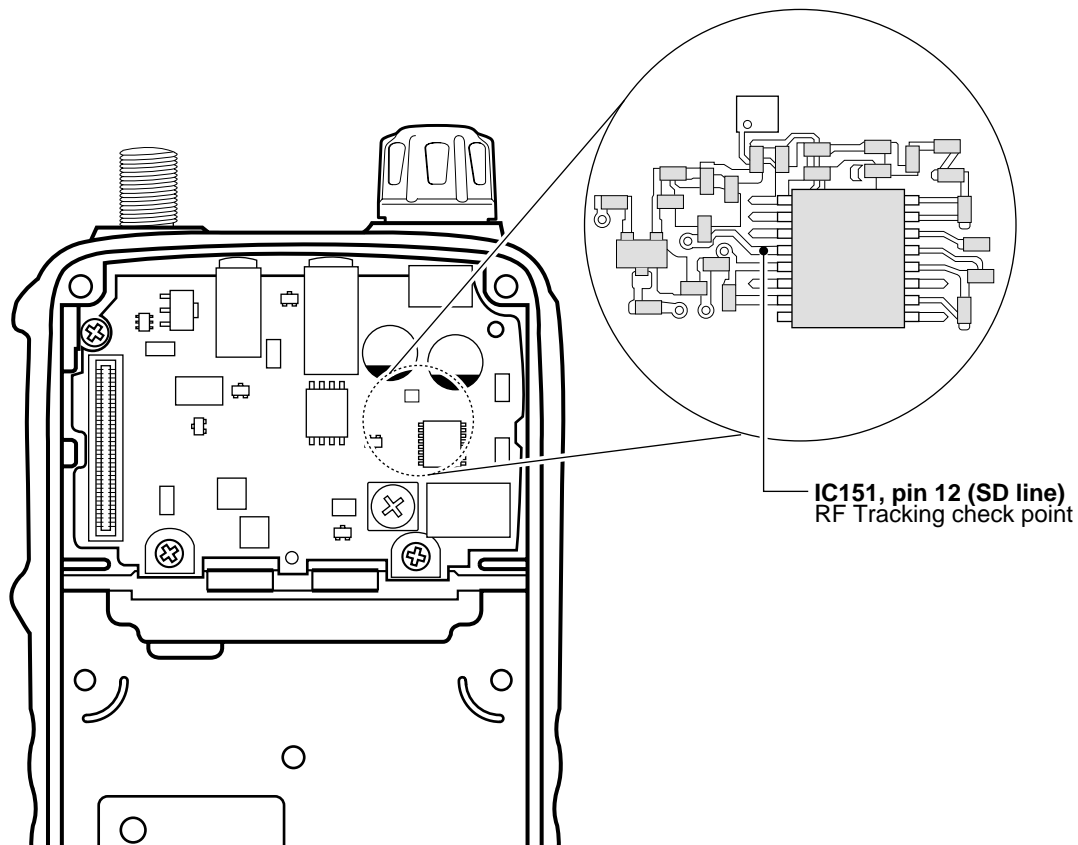

# SECTION 6 PARTS LIST

[RF UNIT]

REF NO.	ORDER NO.	DESCRIPTION
IC51	1110005590	S.IC μPC2762TB-E3
IC101	1110004050	S.IC NJM3404AV-TE1
IC251	1110004530	S.IC M62368GP 70ED
IC351	1110005230	S.IC μPC2757TB-E3
Q1	1590001150	S.TRANSISTOR UN9211 (TX)
Q2	1590001860	S.TRANSISTOR UN9215 (TX)
Q51	1560001150	S.FET 2SK3476 (TE12L)
Q52	1560001160	S.FET 2SK3475 (TE12L)
Q54	1530003790	S.TRANSISTOR 2SC5289-T1
Q56	1590001670	S.TRANSISTOR XP4316 (TX)
Q101	1590002160	S.TRANSISTOR XP6401-(TX)
Q102	1590001860	S.TRANSISTOR UN9215 (TX)
Q205	1590001470	S.TRANSISTOR UN9213 (TX)
Q251	1590002950	S.FET HAT1023R-EL
Q301	1590001470	S.TRANSISTOR UN9213 (TX)
Q302	1530003260	S.TRANSISTOR 2SC5006-T1
Q303	1530003260	S.TRANSISTOR 2SC5006-T1
Q351	1580000740	S.FET 3SK320 (TE85L)
Q352	1590001650	S.TRANSISTOR XP4601 (TX)
Q353	1590001660	S.TRANSISTOR XP4312 (TX)
Q354	1530003760	S.TRANSISTOR 2SC5508-T2
Q355	1590001690	S.TRANSISTOR UN9115 (TX)
Q356	1590001660	S.TRANSISTOR XP4312 (TX)
Q401	1530003810	S.TRANSISTOR 2SC5008-T1
Q402	1530003260	S.TRANSISTOR 2SC5006-T1
Q451	1530003780	S.TRANSISTOR 2SC5624VH-TL
Q452	1530003810	S.TRANSISTOR 2SC5008-T1
Q453	1590001440	S.TRANSISTOR UN9214 (TX)
D2	1790001620	S.DIODE 1SV308 (TPL3)
D3	1790000850	S.DIODE MA132WK (TX)
D4	1750000580	S.DIODE 1SV307 (TPH3)
D6	1790001620	S.DIODE 1SV308 (TPL3)
D7	1790001620	S.DIODE 1SV308 (TPL3)
D8	1790001620	S.DIODE 1SV308 (TPL3)
D9	1790001620	S.DIODE 1SV308 (TPL3)
D10	1790001620	S.DIODE 1SV308 (TPL3)
D12	1750000530	S.DIODE 1SV271 (TPH3)
D13	1750000530	S.DIODE 1SV271 (TPH3)
D16	1750000530	S.DIODE 1SV271 (TPH3)
D18	1790001620	S.DIODE 1SV308 (TPL3)
D19	1750000530	S.DIODE 1SV271 (TPH3)
D50	1790001200	S.DIODE MA6S121 (TX)
D51	1750000800	S.DIODE HVC136TRF
D54	1750000860	S.DIODE HVC132
D57	1790001620	S.DIODE 1SV308 (TPL3)
D201	1750000800	S.DIODE HVC136TRF
D251	1750000540	S.DIODE RB060L-40 TE-25
D252	1790001240	S.DIODE MA2S728-(TX)
D301	1750000800	S.DIODE HVC136TRF
D302	1790001260	S.DIODE MA2S077-(TX)
D303	1750000800	S.DIODE HVC136TRF
D304	1790001200	S.DIODE MA6S121 (TX)
D305	1790001160	S.DIODE 1SS362 (TE85R)
D306	1750000800	S.DIODE HVC136TRF
D307	1790001260	S.DIODE MA2S077-(TX)
D308	1720000790	S.VARICAP HVC321B1TRF
D309	1790001260	S.DIODE MA2S077-(TX)
D310	1720000790	S.VARICAP HVC321B1TRF
D313	1750000800	S.DIODE HVC136TRF
D351	1790001160	S.DIODE 1SS362 (TE85R)
D352	1790001260	S.DIODE MA2S077-(TX)
D353	1720000800	S.VARICAP 1SV290 (TPH3)
D354	1790001260	S.DIODE MA2S077-(TX)
D355	1720000800	S.VARICAP 1SV290 (TPH3)
D356	1720000800	S.VARICAP 1SV290 (TPH3)
D358	1750000800	S.DIODE HVC136TRF
D359	1790001260	S.DIODE MA2S077-(TX)
D360	1790001250	S.DIODE MA2S111-(TX)
D401	1790001160	S.DIODE 1SS362 (TE85R)
D402	1790001260	S.DIODE MA2S077-(TX)
D403	1720000790	S.VARICAP HVC321B1TRF
D404	1790001260	S.DIODE MA2S077-(TX)

[RF UNIT]

REF NO.	ORDER NO.	DESCRIPTION
D405	1720000790	S.VARICAP HVC321B1TRF
D406	1790001260	S.DIODE MA2S077-(TX)
D407	1720000790	S.VARICAP HVC321B1TRF
D408	1750000800	S.DIODE HVC136TRF
D451	1790001160	S.DIODE 1SS362 (TE85R)
D452	1720000790	S.VARICAP HVC321B1TRF
D453	1720000790	S.VARICAP HVC321B1TRF
D454	1720000790	S.VARICAP HVC321B1TRF
D455	1750000800	S.DIODE HVC136TRF
D456	1790001250	S.DIODE MA2S111-(TX)
D457	1790001620	S.DIODE 1SV308 (TPL3)
FI1	4580000130	S.FILTER GLP10-512M
L1	6200010200	S.COIL 0.26-0.9-8TR 26N
L3	6200005660	S.COIL ELJRE 10NG-F
L4	6200005670	S.COIL ELJRE 12NG-F
L5	6200008260	S.COIL 0.30-1.7-8TL 60N
L6	6200008150	S.COIL 0.35-1.6-7TL 44N
L9	6200007810	S.COIL LQH31HN95NK01L (LQN 1H 95NK04)
L11	6200008360	S.COIL 0.25-1.9-13TL
L12	6200008360	S.COIL 0.25-1.9-13TL
L13	6200008360	S.COIL 0.25-1.9-13TL
L14	6200004480	S.COIL MLF1608D R82K-T
L15	6200004480	S.COIL MLF1608D R82K-T
L16	6200008510	S.COIL 0.30-0.9-4TR 10.5N
L17	6200004480	S.COIL MLF1608D R82K-T
L18	6200008260	S.COIL 0.30-1.7-8TL 60N
L19	6200008480	S.COIL 0.30-1.4-5TR 25N
L20	6200004480	S.COIL MLF1608D R82K-T
L21	6200004480	S.COIL MLF1608D R82K-T
L22	6200008190	S.COIL 0.25-1.9-8TL 80N
L23	6200008210	S.COIL 0.45-1.5-5TL 23.2N
L24	6200008300	S.COIL 0.35-1.6-9TL 65N
L25	6200004480	S.COIL MLF1608D R82K-T
L26	6200004480	S.COIL MLF1608D R82K-T
L30	6200009980	S.COIL C2012C-18NG
L32	6200009930	S.COIL C2012C-68NG
L34	6200010320	S.COIL C2012C-R15G
L51	6200010260	S.COIL 0.40-1.5-5TL 24N
L53	6200010410	S.COIL ELJRE 1NOZ-F2
L54	6200006670	S.COIL ELJRE 68NG-F
L56	6200006990	S.COIL ELJRE 56NG-F
L57	6200009990	S.COIL C2012C-R22G
L65	6200002630	S.COIL NL 252018T-R10J
L66	6200007810	S.COIL LQH31HN95NK01L (LQN 1H 95NK04)
L68	6200010410	S.COIL ELJRE 1NOZ-F2
L101	6200003640	S.COIL MLF1608E 100K-T
L102	6200004480	S.COIL MLF1608D R82K-T
L252	6200003590	S.COIL EXCCL3225U1
L253	6200003590	S.COIL EXCCL3225U1
L301	6200007170	S.COIL MLF1608A 3R3K-T
L302	6200003350	S.COIL ELJNC R27K-F
L303	6200010350	S.COIL C2012C-R27G
L304	6200007340	S.COIL ELJND R22J 0.22U
L306	6200010340	S.COIL C2012C-R33G
L307	6200007340	S.COIL ELJND R22J 0.22U
L351	6200010010	S.COIL C2012C-39NG
L352	6200010010	S.COIL C2012C-39NG
L353	6200007820	S.COIL ELJND R33J 0.33U
L354	6200010100	S.COIL C2012C-33NG
L355	6200010010	S.COIL C2012C-39NG
L357	6200010100	S.COIL C2012C-33NG
L358	6200010010	S.COIL C2012C-39NG
L359	6200005710	S.COIL ELJRE 27NG-F
L401	6200010130	S.COIL LQW18AN6N8C00
L402	6200010120	S.COIL LQW18AN5N6C00
L403	6200010130	S.COIL LQW18AN6N8C00
L404	6200010130	S.COIL LQW18AN6N8C00
L405	6200010130	S.COIL LQW18AN6N8C00
L406	6200010130	S.COIL LQW18AN6N8C00
L408	6200005700	S.COIL ELJRE 22NG-F
L409	6200009070	S.COIL LQW18AN18NG00D (LQW1608A18NG00)
L451	6200005600	S.COIL ELJRE 3N3Z-F

S.=Surface mount



## [RF UNIT]

REF NO.	ORDER NO.	DESCRIPTION	
L452	6200005610	S.COIL	ELJRE 3N9Z-F
L453	6200005610	S.COIL	ELJRE 3N9Z-F
L454	6200006980	S.COIL	ELJRE R10G-F
L455	6200005720	S.COIL	ELJRE 33NG-F
L456	6200010240	S.COIL	0.4-0.8-2TL
R1	7030009280	S.RESISTOR	ERJ2GE
R2	7030004980	S.RESISTOR	ERJ2GEJ 101 X (100 Ω)
R6	7030004980	S.RESISTOR	ERJ2GEJ 101 X (100 Ω)
R7	7030007270	S.RESISTOR	ERJ2GEJ 151 X (150 Ω)
R8	7510001660	S.THRMISTOR	NTCG16 4LH 473KT
R9	7030005240	S.RESISTOR	ERJ2GEJ 473 X (47 kΩ)
R10	7030007290	S.RESISTOR	ERJ2GEJ 222 X (2.2 kΩ)
R11	7030007290	S.RESISTOR	ERJ2GEJ 222 X (2.2 kΩ)
R13	7030009280	S.RESISTOR	ERJ2GE
R16	7030009280	S.RESISTOR	ERJ2GE
R40	7030005040	S.RESISTOR	ERJ2GEJ 472 X (4.7 kΩ)
R41	7030005040	S.RESISTOR	ERJ2GEJ 472 X (4.7 kΩ)
R51	7030005050	S.RESISTOR	ERJ2GEJ 103 X (10 kΩ)
R52	7030007250	S.RESISTOR	ERJ2GEJ 220 X (22 Ω)
R53	7030007280	S.RESISTOR	ERJ2GEJ 331 X (330 Ω)
R54	7030007270	S.RESISTOR	ERJ2GEJ 151 X (150 Ω)
R55	7030005120	S.RESISTOR	ERJ2GEJ 102 X (1 kΩ)
R56	7030009200	S.RESISTOR	ERJ2GEJ 390 X (39 Ω)
R57	7030005090	S.RESISTOR	ERJ2GEJ 104 X (100 kΩ)
R59	7030005030	S.RESISTOR	ERJ2GEJ 152 X (1.5 kΩ)
R60	7030009270	S.RESISTOR	ERJ2GEJ 821 X (820 Ω)
R61	7030004990	S.RESISTOR	ERJ2GEJ 221 X (220 Ω)
R63	7030005000	S.RESISTOR	ERJ2GEJ 471 X (470 Ω)
R64	7030005120	S.RESISTOR	ERJ2GEJ 102 X (1 kΩ)
R73	7030007290	S.RESISTOR	ERJ2GEJ 222 X (2.2 kΩ)
R77	7030005120	S.RESISTOR	ERJ2GEJ 102 X (1 kΩ)
R78	7030005580	S.RESISTOR	ERJ2GEJ 560 X (56 Ω)
R79	7030005580	S.RESISTOR	ERJ2GEJ 560 X (56 Ω)
R80	7030007280	S.RESISTOR	ERJ2GEJ 331 X (330 Ω)
R81	7030007280	S.RESISTOR	ERJ2GEJ 331 X (330 Ω)
R82	7030010670	S.RESISTOR	ERJ2GEJ 3R9X (3.9 Ω)
R101	7030005160	S.RESISTOR	ERJ2GEJ 105 X (1 MΩ)
R102	7030005230	S.RESISTOR	ERJ2GEJ 334 X (330 kΩ)
R103	7030005110	S.RESISTOR	ERJ2GEJ 224 X (220 kΩ)
R104	7030005160	S.RESISTOR	ERJ2GEJ 105 X (1 MΩ)
R105	7030005050	S.RESISTOR	ERJ2GEJ 103 X (10 kΩ)
R106	7030005050	S.RESISTOR	ERJ2GEJ 103 X (10 kΩ)
R107	7030005230	S.RESISTOR	ERJ2GEJ 334 X (330 kΩ)
R108	7030005110	S.RESISTOR	ERJ2GEJ 224 X (220 kΩ)
R109	7030007330	S.RESISTOR	ERJ1WRSJR15U (0.15 Ω)
R110	7030008400	S.RESISTOR	ERJ2GEJ 182 X (1.8 kΩ)
R111	7030005050	S.RESISTOR	ERJ2GEJ 103 X (10 kΩ)
R112	7030005230	S.RESISTOR	ERJ2GEJ 334 X (330 kΩ)
R205	7030007570	S.RESISTOR	ERJ2GEJ 122X (1.2 kΩ)
R206	7030005080	S.RESISTOR	ERJ2GEJ 823 X (82 kΩ)
R209	7030005120	S.RESISTOR	ERJ2GEJ 102 X (1 kΩ)
R251	7030005090	S.RESISTOR	ERJ2GEJ 104 X (100 kΩ)
R301	7030007290	S.RESISTOR	ERJ2GEJ 222 X (2.2 kΩ)
R302	7030007290	S.RESISTOR	ERJ2GEJ 222 X (2.2 kΩ)
R303	7030005050	S.RESISTOR	ERJ2GEJ 103 X (10 kΩ)
R304	7030005220	S.RESISTOR	ERJ2GEJ 223 X (22 kΩ)
R305	7030004980	S.RESISTOR	ERJ2GEJ 101 X (100 Ω)
R306	7030004990	S.RESISTOR	ERJ2GEJ 221 X (220 Ω)
R307	7030005120	S.RESISTOR	ERJ2GEJ 102 X (1 kΩ)
R308	7030007290	S.RESISTOR	ERJ2GEJ 222 X (2.2 kΩ)
R309	7030007290	S.RESISTOR	ERJ2GEJ 222 X (2.2 kΩ)
R310	7030005050	S.RESISTOR	ERJ2GEJ 103 X (10 kΩ)
R311	7030007350	S.RESISTOR	ERJ2GEJ 393 X (39 kΩ)
R312	7030004990	S.RESISTOR	ERJ2GEJ 221 X (220 Ω)
R313	7030005030	S.RESISTOR	ERJ2GEJ 152 X (1.5 kΩ)
R314	7030005090	S.RESISTOR	ERJ2GEJ 104 X (100 kΩ)
R315	7030009160	S.RESISTOR	ERJ2GEJ 181 X (180 Ω)
R316	7030005090	S.RESISTOR	ERJ2GEJ 104 X (100 kΩ)
R317	7030007290	S.RESISTOR	ERJ2GEJ 222 X (2.2 kΩ)
R318	7030005030	S.RESISTOR	ERJ2GEJ 152 X (1.5 kΩ)
R351	7030005120	S.RESISTOR	ERJ2GEJ 102 X (1 kΩ)
R352	7030005040	S.RESISTOR	ERJ2GEJ 472 X (4.7 kΩ)
R353	7030005070	S.RESISTOR	ERJ2GEJ 683 X (68 kΩ)
R354	7030005240	S.RESISTOR	ERJ2GEJ 473 X (47 kΩ)
R355	7030005240	S.RESISTOR	ERJ2GEJ 473 X (47 kΩ)
R356	7030009200	S.RESISTOR	ERJ2GEJ 390 X (39 Ω)
R357	7030007250	S.RESISTOR	ERJ2GEJ 220 X (22 Ω)
R358	7030005090	S.RESISTOR	ERJ2GEJ 104 X (100 kΩ)
R359	7030005090	S.RESISTOR	ERJ2GEJ 104 X (100 kΩ)
R360	7030005040	S.RESISTOR	ERJ2GEJ 472 X (4.7 kΩ)

## [RF UNIT]

REF NO.	ORDER NO.	DESCRIPTION	
R361	7030007290	S.RESISTOR	ERJ2GEJ 222 X (2.2 kΩ)
R362	7030007300	S.RESISTOR	ERJ2GEJ 332 X (3.3 kΩ)
R363	7030007570	S.RESISTOR	ERJ2GEJ 122X (1.2 kΩ)
R364	7030005830	S.RESISTOR	RR0510R-223-D (22 kΩ)
R365	7030005860	S.RESISTOR	RR0510R-823-D (82 kΩ)
R366	7030005090	S.RESISTOR	ERJ2GEJ 104 X (100 kΩ)
R367	7030005580	S.RESISTOR	ERJ2GEJ 560 X (56 Ω)
R368	7030004970	S.RESISTOR	ERJ2GEJ 470 X (47 Ω)
R369	7030007290	S.RESISTOR	ERJ2GEJ 222 X (2.2 kΩ)
R401	7030005120	S.RESISTOR	ERJ2GEJ 102 X (1 kΩ)
R402	7030005090	S.RESISTOR	ERJ2GEJ 104 X (100 kΩ)
R403	7030005050	S.RESISTOR	ERJ2GEJ 103 X (10 kΩ)
R404	7030005720	S.RESISTOR	ERJ2GEJ 563 X (56 kΩ)
R405	7030005120	S.RESISTOR	ERJ2GEJ 102 X (1 kΩ)
R407	7030004990	S.RESISTOR	ERJ2GEJ 221 X (220 Ω)
R408	7030005050	S.RESISTOR	ERJ2GEJ 103 X (10 kΩ)
R409	7030008410	S.RESISTOR	ERJ2GEJ 392 X (3.9 kΩ)
R410	7030005090	S.RESISTOR	ERJ2GEJ 104 X (100 kΩ)
R412	7030005720	S.RESISTOR	ERJ2GEJ 563 X (56 kΩ)
R414	7030004990	S.RESISTOR	ERJ2GEJ 221 X (220 Ω)
R415	7030005050	S.RESISTOR	ERJ2GEJ 103 X (10 kΩ)
R416	7030005090	S.RESISTOR	ERJ2GEJ 104 X (100 kΩ)
R417	7030007290	S.RESISTOR	ERJ2GEJ 222 X (2.2 kΩ)
R418	7030007290	S.RESISTOR	ERJ2GEJ 222 X (2.2 kΩ)
R419	7030008410	S.RESISTOR	ERJ2GEJ 392 X (3.9 kΩ)
R420	7030005120	S.RESISTOR	ERJ2GEJ 102 X (1 kΩ)
R451	7030005120	S.RESISTOR	ERJ2GEJ 102 X (1 kΩ)
R452	7030005090	S.RESISTOR	ERJ2GEJ 104 X (100 kΩ)
R453	7030005220	S.RESISTOR	ERJ2GEJ 223 X (22 kΩ)
R454	7030005050	S.RESISTOR	ERJ2GEJ 103 X (10 kΩ)
R456	7030004990	S.RESISTOR	ERJ2GEJ 221 X (220 Ω)
R457	7030005090	S.RESISTOR	ERJ2GEJ 104 X (100 kΩ)
R459	7030005050	S.RESISTOR	ERJ2GEJ 103 X (10 kΩ)
R460	7030004990	S.RESISTOR	ERJ2GEJ 221 X (220 Ω)
R461	7030007280	S.RESISTOR	ERJ2GEJ 331 X (330 Ω)
R462	7030005090	S.RESISTOR	ERJ2GEJ 104 X (100 kΩ)
R463	7030007290	S.RESISTOR	ERJ2GEJ 222 X (2.2 kΩ)
R465	7030007250	S.RESISTOR	ERJ2GEJ 220 X (22 Ω)
R466	7030004970	S.RESISTOR	ERJ2GEJ 470 X (47 Ω)
R467	7030009280	S.RESISTOR	ERJ2GE
R468	7030005050	S.RESISTOR	ERJ2GEJ 103 X (10 kΩ)
R469	7030005120	S.RESISTOR	ERJ2GEJ 102 X (1 kΩ)
R470	7030005120	S.RESISTOR	ERJ2GEJ 102 X (1 kΩ)
R471	7030005120	S.RESISTOR	ERJ2GEJ 102 X (1 kΩ)
C1	4030017620	S.CERAMIC	ECJ0EC1H100C
C2	4030017650	S.CERAMIC	ECJ0EC1H270J
C3	4030017600	S.CERAMIC	ECJ0EC1H080C
C6	4030017350	S.CERAMIC	ECJ0EC1H020B
C7	4030017550	S.CERAMIC	ECJ0EC1H1R5B
C8	4030017360	S.CERAMIC	ECJ0EC1H030B
C9	4030017660	S.CERAMIC	ECJ0EC1H330J
C10	4030017430	S.CERAMIC	ECJ0EC1H101J
C11	4030017670	S.CERAMIC	ECJ0EC1H390J
C17	4030017600	S.CERAMIC	ECJ0EC1H080C
C18	4030017420	S.CERAMIC	ECJ0EC1H470J
C19	4030016790	S.CERAMIC	ECJ0EC1C103K
C21	4030017510	S.CERAMIC	ECJ0EC1H680J
C23	4030007070	S.CERAMIC	C1608 CH 1H 330J-T
C24	4030017640	S.CERAMIC	ECJ0EC1H150J
C26	4030017600	S.CERAMIC	ECJ0EC1H080C
C27	4030017670	S.CERAMIC	ECJ0EC1H390J
C30	4030017460	S.CERAMIC	ECJ0EB1E102K
C31	4030017460	S.CERAMIC	ECJ0EB1E102K
C32	4030017630	S.CERAMIC	ECJ0EC1H120J
C33	4030007010	S.CERAMIC	C1608 CH 1H 100D-T
C34	4030017690	S.CERAMIC	ECJ0EC1H121J
C35	4030017460	S.CERAMIC	ECJ0EB1E102K
C36	4030017570	S.CERAMIC	ECJ0EC1H040B
C37	4030017340	S.CERAMIC	ECJ0EC1H010B
C39	4030017390	S.CERAMIC	ECJ0EC1H180J
C40	4030017650	S.CERAMIC	ECJ0EC1H270J
C41	4030017500	S.CERAMIC	ECJ0EC1H560J
C42	4030017500	S.CERAMIC	ECJ0EC1H560J
C43	4030017400	S.CERAMIC	ECJ0EC1H220J
C44	4030017500	S.CERAMIC	ECJ0EC1H560J
C51	4030017330	S.CERAMIC	ECJ0EF1C104Z
C52	4550007000	S.TANTALUM	ECST1VY105R
C55	4030017460	S.CERAMIC	ECJ0EB1E102K
C57	4030017330	S.CERAMIC	ECJ0EF1C104Z
C59	4030018010	S.CERAMIC	ECJ0EC1H360J

S.=Surface mount

## [RF UNIT]

REF NO.	ORDER NO.	DESCRIPTION
C60	4030017510	S.CERAMIC ECJ0EC1H680J
C62	4030016790	S.CERAMIC ECJ0EB1C103K
C64	4030017330	S.CERAMIC ECJ0EF1C104Z
C65	4030017640	S.CERAMIC ECJ0EC1H150J
C66	4030017460	S.CERAMIC ECJ0EB1E102K
C67	4030016790	S.CERAMIC ECJ0EB1C103K
C68	4030017660	S.CERAMIC ECJ0EC1H330J
C69	4030017460	S.CERAMIC ECJ0EB1E102K
C70	4030016790	S.CERAMIC ECJ0EB1C103K
C76	4030016790	S.CERAMIC ECJ0EB1C103K
C77	4030017630	S.CERAMIC ECJ0EC1H120J
C78	4030017330	S.CERAMIC ECJ0EF1C104Z
C79	4030017460	S.CERAMIC ECJ0EB1E102K
C80	4030017330	S.CERAMIC ECJ0EF1C104Z
C81	4030016790	S.CERAMIC ECJ0EB1C103K
C82	4030017460	S.CERAMIC ECJ0EB1E102K
C83	4030017460	S.CERAMIC ECJ0EB1E102K
C84	4030017460	S.CERAMIC ECJ0EB1E102K
C85	4030017460	S.CERAMIC ECJ0EB1E102K
C87	4030016790	S.CERAMIC ECJ0EB1C103K
C88	4030017460	S.CERAMIC ECJ0EB1E102K
C89	4030017330	S.CERAMIC ECJ0EF1C104Z
C91	4030016790	S.CERAMIC ECJ0EB1C103K
C92	4030017460	S.CERAMIC ECJ0EB1E102K
C93	4030016790	S.CERAMIC ECJ0EB1C103K
C94	4030016790	S.CERAMIC ECJ0EB1C103K
C95	4030016790	S.CERAMIC ECJ0EB1C103K
C98	4030018220	S.CERAMIC ERA21B6C2D300JD01L (GRH708 CH)
C101	4030017330	S.CERAMIC ECJ0EF1C104Z
C102	4030017330	S.CERAMIC ECJ0EF1C104Z
C103	4030017330	S.CERAMIC ECJ0EF1C104Z
C104	4030017330	S.CERAMIC ECJ0EF1C104Z
C105	4030017460	S.CERAMIC ECJ0EB1E102K
C106	4030017460	S.CERAMIC ECJ0EB1E102K
C107	4030017460	S.CERAMIC ECJ0EB1E102K
C108	4030017460	S.CERAMIC ECJ0EB1E102K
C109	4030017460	S.CERAMIC ECJ0EB1E102K
C110	4030017330	S.CERAMIC ECJ0EF1C104Z
C111	4030017330	S.CERAMIC ECJ0EF1C104Z
C112	4030017460	S.CERAMIC ECJ0EB1E102K
C114	4030017460	S.CERAMIC ECJ0EB1E102K
C115	4030016790	S.CERAMIC ECJ0EB1C103K
C116	4030017460	S.CERAMIC ECJ0EB1E102K
C204	4030017460	S.CERAMIC ECJ0EB1E102K
C205	4030017460	S.CERAMIC ECJ0EB1E102K
C220	4030017460	S.CERAMIC ECJ0EB1E102K
C252	4030017460	S.CERAMIC ECJ0EB1E102K
C253	4550007000	S.TANTALUM ECST1VY105R
C254	4030017460	S.CERAMIC ECJ0EB1E102K
C255	4030017460	S.CERAMIC ECJ0EB1E102K
C256	4030017460	S.CERAMIC ECJ0EB1E102K
C257	4030016790	S.CERAMIC ECJ0EB1C103K
C258	4030017330	S.CERAMIC ECJ0EF1C104Z
C259	4030017460	S.CERAMIC ECJ0EB1E102K
C301	4030018100	S.CERAMIC ECJ0EB1H681K
C302	4030016930	S.CERAMIC ECJ0EB1A104K
C303	4030018100	S.CERAMIC ECJ0EB1H681K
C304	4030017680	S.CERAMIC ECJ0EC1H820J
C305	4030017660	S.CERAMIC ECJ0EC1H330J
C306	4030017690	S.CERAMIC ECJ0EC1H121J
C307	4030016930	S.CERAMIC ECJ0EB1A104K
C308	4030016930	S.CERAMIC ECJ0EB1A104K
C309	4030016930	S.CERAMIC ECJ0EB1A104K
C310	4030016930	S.CERAMIC ECJ0EB1A104K
C311	4030017460	S.CERAMIC ECJ0EB1E102K
C314	4030016930	S.CERAMIC ECJ0EB1A104K
C315	4030016930	S.CERAMIC ECJ0EB1A104K
C316	4030016930	S.CERAMIC ECJ0EB1A104K
C317	4030017640	S.CERAMIC ECJ0EC1H150J
C318	4030016790	S.CERAMIC ECJ0EB1C103K
C319	4030017460	S.CERAMIC ECJ0EB1E102K
C320	4030017620	S.CERAMIC ECJ0EC1H100C
C321	4030016790	S.CERAMIC ECJ0EB1C103K
C323	4030017610	S.CERAMIC ECJ0EC1H090C
C324	4030016790	S.CERAMIC ECJ0EB1C103K
C325	4030017460	S.CERAMIC ECJ0EB1E102K
C331	4030017630	S.CERAMIC ECJ0EC1H120J
C332	4030016790	S.CERAMIC ECJ0EB1C103K
C333	4030016930	S.CERAMIC ECJ0EB1A104K
C351	4030017460	S.CERAMIC ECJ0EB1E102K
C352	4030017380	S.CERAMIC ECJ0EC1H050B
C353	4030017460	S.CERAMIC ECJ0EB1E102K

## [RF UNIT]

REF NO.	ORDER NO.	DESCRIPTION
C354	4030017460	S.CERAMIC ECJ0EB1E102K
C355	4030017460	S.CERAMIC ECJ0EB1E102K
C356	4030017460	S.CERAMIC ECJ0EB1E102K
C357	4030017460	S.CERAMIC ECJ0EB1E102K
C358	4030017460	S.CERAMIC ECJ0EB1E102K
C359	4030017440	S.CERAMIC ECJ0EC1H221J
C360	4030017590	S.CERAMIC ECJ0EC1H070C
C361	4030017620	S.CERAMIC ECJ0EC1H100C
C362	4030017430	S.CERAMIC ECJ0EC1H101J
C363	4030017460	S.CERAMIC ECJ0EB1E102K
C364	4030017640	S.CERAMIC ECJ0EC1H150J
C365	4030017460	S.CERAMIC ECJ0EB1E102K
C367	4030017570	S.CERAMIC ECJ0EC1H040B
C368	4030016790	S.CERAMIC ECJ0EB1C103K
C369	4030017460	S.CERAMIC ECJ0EB1E102K
C370	4030017610	S.CERAMIC ECJ0EC1H090C
C371	4030017460	S.CERAMIC ECJ0EB1E102K
C372	4030017440	S.CERAMIC ECJ0EC1H221J
C373	4030017460	S.CERAMIC ECJ0EB1E102K
C374	4030017460	S.CERAMIC ECJ0EB1E102K
C375	4030017520	S.CERAMIC ECJ0EC1H0R3B
C376	4030017460	S.CERAMIC ECJ0EB1E102K
C401	4030017400	S.CERAMIC ECJ0EC1H220J
C402	4030017350	S.CERAMIC ECJ0EC1H020B
C403	4030017460	S.CERAMIC ECJ0EB1E102K
C404	4030017570	S.CERAMIC ECJ0EC1H040B
C405	4030017460	S.CERAMIC ECJ0EB1E102K
C406	4030017430	S.CERAMIC ECJ0EC1H101J
C407	4030017460	S.CERAMIC ECJ0EB1E102K
C408	4030017460	S.CERAMIC ECJ0EB1E102K
C409	4030017710	S.CERAMIC ECJ0EC1H181J
C410	4030017460	S.CERAMIC ECJ0EB1E102K
C411	4030017360	S.CERAMIC ECJ0EC1H030B
C412	4030017460	S.CERAMIC ECJ0EB1E102K
C413	4030017460	S.CERAMIC ECJ0EB1E102K
C414	4030017530	S.CERAMIC ECJ0EC1H0R5B
C415	4030017430	S.CERAMIC ECJ0EC1H101J
C416	4030017620	S.CERAMIC ECJ0EC1H100C
C417	4030017460	S.CERAMIC ECJ0EB1E102K
C419	4030017460	S.CERAMIC ECJ0EB1E102K
C420	4030016790	S.CERAMIC ECJ0EB1C103K
C421	4030016790	S.CERAMIC ECJ0EB1C103K
C451	4030017430	S.CERAMIC ECJ0EC1H101J
C452	4030017570	S.CERAMIC ECJ0EC1H040B
C453	4030017510	S.CERAMIC ECJ0EC1H680J
C454	4030017380	S.CERAMIC ECJ0EC1H050B
C455	4030017460	S.CERAMIC ECJ0EB1E102K
C456	4030017510	S.CERAMIC ECJ0EC1H680J
C457	4030017460	S.CERAMIC ECJ0EB1E102K
C458	4030017570	S.CERAMIC ECJ0EC1H040B
C460	4030017340	S.CERAMIC ECJ0EC1H010B
C461	4030017460	S.CERAMIC ECJ0EB1E102K
C462	4030017570	S.CERAMIC ECJ0EC1H040B
C463	4030017680	S.CERAMIC ECJ0EC1H820J
C464	4030017430	S.CERAMIC ECJ0EC1H101J
C465	4030016790	S.CERAMIC ECJ0EB1C103K
C466	4030017460	S.CERAMIC ECJ0EB1E102K
C467	4030017460	S.CERAMIC ECJ0EB1E102K
C468	4030017460	S.CERAMIC ECJ0EB1E102K
C469	4030017460	S.CERAMIC ECJ0EB1E102K
C470	4030017460	S.CERAMIC ECJ0EB1E102K
C472	4030017730	S.CERAMIC ECJ0EB1E471K
C473	4030016790	S.CERAMIC ECJ0EB1C103K
C474	4030017460	S.CERAMIC ECJ0EB1E102K
C476	4030017460	S.CERAMIC ECJ0EB1E102K
C477	4030017460	S.CERAMIC ECJ0EB1E102K
C478	4030016790	S.CERAMIC ECJ0EB1C103K
C479	4030016790	S.CERAMIC ECJ0EB1C103K
C480	4030017690	S.CERAMIC ECJ0EC1H121J
C481	4030017640	S.CERAMIC ECJ0EC1H150J
C482	4030017510	S.CERAMIC ECJ0EC1H680J
C483	4030017630	S.CERAMIC ECJ0EC1H120J
C484	4030017350	S.CERAMIC ECJ0EC1H020B
C485	4030017650	S.CERAMIC ECJ0EC1H270J
C486	4030017570	S.CERAMIC ECJ0EC1H040B
C487	4030017570	S.CERAMIC ECJ0EC1H040B
C488	4030017460	S.CERAMIC ECJ0EB1E102K
C489	4030016790	S.CERAMIC ECJ0EB1C103K
C490	4030017460	S.CERAMIC ECJ0EB1E102K
C492	4030017400	S.CERAMIC ECJ0EC1H220J

S.=Surface mount

[RF UNIT]

REF NO.	ORDER NO.	DESCRIPTION	
J251	6510022860	S.CONNECTOR	AXK6S30445P
J252	6450000870	CONNECTOR	HEC2711-01-020
W1	7030010040	S.JUMPER	ERJ2GE-JPW
W2	7030010040	S.JUMPER	ERJ2GE-JPW
EP1	0910055443	PCB	B 5845C
EP2	6910013310	S.BEAD	MMZ1608D121B
EP3	6910014640	S.BEAD	MPZ2012S221A-T
EP4	6910014640	S.BEAD	MPZ2012S221A-T
EP5	6910014640	S.BEAD	MPZ2012S221A-T
EP6	6910014640	S.BEAD	MPZ2012S221A-T

[AF UNIT]

REF NO.	ORDER NO.	DESCRIPTION	
IC51	1130007570	S.IC	BU4094BCFV-E2
IC151	1110003200	S.IC	TA31136FN (EL)
IC251	1110004520	S.IC	M5222FP 600C
IC252	1110001810	S.IC	TA7368F (TP1)
Q1	1530003010	S.TRANSISTOR	2SC4117-GR (TE85R)
Q2	1530003220	S.TRANSISTOR	2SC4406-4-TL
Q11	1590001170	S.TRANSISTOR	XP1501-(TX) .AB
Q51	1510000670	S.TRANSISTOR	2SA1588-GR (TE85R)
Q52	1510000670	S.TRANSISTOR	2SA1588-GR (TE85R)
Q53	1510000670	S.TRANSISTOR	2SA1588-GR (TE85R)
Q54	1590002700	S.TRANSISTOR	XP4214 (TX)
Q55	1520000460	S.TRANSISTOR	2SB1132 T100 R
Q56	1590002700	S.TRANSISTOR	XP4214 (TX)
Q57	1540000350	S.TRANSISTOR	2SD2216-S (TX)
Q58	1590002380	S.TRANSISTOR	XP1115 (TX)
Q59	1590001690	S.TRANSISTOR	UN9115 (TX)
Q61	1590001690	S.TRANSISTOR	UN9115 (TX)
Q62	1590002380	S.TRANSISTOR	XP1115 (TX)
Q63	1590002380	S.TRANSISTOR	XP1115 (TX)
Q64	1510000620	S.TRANSISTOR	2SA1576 T106 S
Q65	1590001730	S.TRANSISTOR	UN9113 (TX)
Q66	1590001730	S.TRANSISTOR	UN9113 (TX)
Q67	1590001730	S.TRANSISTOR	UN9113 (TX)
Q101	1590001980	S.TRANSISTOR	XP4315 (TX)
Q102	1530002560	S.TRANSISTOR	2SC4403-3-TL
Q103	1590001730	S.TRANSISTOR	UN9113 (TX)
Q201	1590001190	S.TRANSISTOR	XP6501-(TX) .AB
Q202	1590001190	S.TRANSISTOR	XP6501-(TX) .AB
Q203	1550000010	S.FET	2SJ364-Q (TX)
Q204	1590001190	S.TRANSISTOR	XP6501-(TX) .AB
Q205	1540000350	S.TRANSISTOR	2SD2216-S (TX)
Q206	1590001980	S.TRANSISTOR	XP4315 (TX)
Q207	1590002380	S.TRANSISTOR	XP1115 (TX)
Q208	1510000510	S.TRANSISTOR	2SA1576A T106R
Q209	1590001170	S.TRANSISTOR	XP1501-(TX) .AB
Q251	1550000010	S.FET	2SJ364-Q (TX)
Q253	1590001690	S.TRANSISTOR	UN9115 (TX)
D1	1750000770	S.VARICAP	HVC376BTRF
D2	1750000360	S.DIODE	1SS364 (TE85L)
D3	1750000360	S.DIODE	1SS364 (TE85L)
D51	1790001240	S.DIODE	MA2S728-(TX)
D52	1790001250	S.DIODE	MA2S111-(TX)
D101	1750000360	S.DIODE	1SS364 (TE85L)
D102	1750000360	S.DIODE	1SS364 (TE85L)
D103	1790000860	S.DIODE	MA133 (TX)
D104	1790001250	S.DIODE	MA2S111-(TX)
D151	1750000360	S.DIODE	1SS364 (TE85L)
D152	1750000360	S.DIODE	1SS364 (TE85L)
D201	1750000360	S.DIODE	1SS364 (TE85L)
FI101	2020001950	S.CERAMIC	FL-338 (69.450 MHz)
FI102	2020001940	S.CERAMIC	SFEC513M3DA0001-B0 (SFEC513.35M)
FI151	2020001270	CERAMIC	CFWLB450KE2A-B0 (CFWM450E)

[AF UNIT]

REF NO.	ORDER NO.	DESCRIPTION	
X1	6050010160	S.XTAL	CR-583 (13.800 MHz)
L3	6200004600	S.COIL	MLF1608D R15K-T
L4	6200004590	S.COIL	MLF1608D R18K-T
L5	6200004590	S.COIL	MLF1608D R18K-T
L8	6200005700	S.COIL	ELJRE 22NG-F
L9	6200004600	S.COIL	MLF1608D R15K-T
L101	6200004480	S.COIL	MLF1608D R82K-T
L103	6200004780	S.COIL	MLF1608A 1R5K-T
L104	6200001980	S.COIL	NL 252018T-1R0J
L151	6150005010	S.COIL	LS-528 (637AN-0223GW=P3)
R1	7030005600	S.RESISTOR	ERJ2GEJ 273 X (27 kΩ)
R2	7030005090	S.RESISTOR	ERJ2GEJ 104 X (100 kΩ)
R3	7030005090	S.RESISTOR	ERJ2GEJ 104 X (100 kΩ)
R4	7030006610	S.RESISTOR	ERJ2GEJ 394 X (390 kΩ)
R5	7030004970	S.RESISTOR	ERJ2GEJ 470 X (4.7 kΩ)
R7	7030005120	S.RESISTOR	ERJ2GEJ 102 X (1 kΩ)
R8	7030005240	S.RESISTOR	ERJ2GEJ 473 X (47 kΩ)
R9	7030004970	S.RESISTOR	ERJ2GEJ 470 X (47 Ω)
R10	7030008010	S.RESISTOR	ERJ2GEJ 123 X (12 kΩ)
R11	7030008400	S.RESISTOR	ERJ2GEJ 182 X (1.8 kΩ)
R12	7030008010	S.RESISTOR	ERJ2GEJ 123 X (12 kΩ)
R13	7030008010	S.RESISTOR	ERJ2GEJ 123 X (12 kΩ)
R51	7030005040	S.RESISTOR	ERJ2GEJ 472 X (4.7 kΩ)
R52	7030005000	S.RESISTOR	ERJ2GEJ 471 X (470 Ω)
R54	7030005040	S.RESISTOR	ERJ2GEJ 472 X (4.7 kΩ)
R55	7030005000	S.RESISTOR	ERJ2GEJ 471 X (470 Ω)
R56	7030005040	S.RESISTOR	ERJ2GEJ 472 X (4.7 kΩ)
R57	7030005000	S.RESISTOR	ERJ2GEJ 471 X (470 Ω)
R58	7030005050	S.RESISTOR	ERJ2GEJ 103 X (10 kΩ)
R59	7030005050	S.RESISTOR	ERJ2GEJ 103 X (10 kΩ)
R60	7030005000	S.RESISTOR	ERJ2GEJ 471 X (470 Ω)
R61	7030005090	S.RESISTOR	ERJ2GEJ 104 X (100 kΩ)
R62	7030005160	S.RESISTOR	ERJ2GEJ 105 X (1 MΩ)
R63	7030005040	S.RESISTOR	ERJ2GEJ 472 X (4.7 kΩ)
R64	7030007290	S.RESISTOR	ERJ2GEJ 222 X (2.2 kΩ)
R101	7030005040	S.RESISTOR	ERJ2GEJ 472 X (4.7 kΩ)
R102	7030005040	S.RESISTOR	ERJ2GEJ 472 X (4.7 kΩ)
R103	7030005040	S.RESISTOR	ERJ2GEJ 472 X (4.7 kΩ)
R104	7030005040	S.RESISTOR	ERJ2GEJ 472 X (4.7 kΩ)
R105	7030005040	S.RESISTOR	ERJ2GEJ 472 X (4.7 kΩ)
R107	7030007340	S.RESISTOR	ERJ2GEJ 153 X (1.5 kΩ)
R108	7030005290	S.RESISTOR	ERJ2GEJ 682 X (6.8 kΩ)
R109	7030004970	S.RESISTOR	ERJ2GEJ 470 X (47 Ω)
R110	7030004990	S.RESISTOR	ERJ2GEJ 221 X (220 Ω)
R111	7030004990	S.RESISTOR	ERJ2GEJ 221 X (220 Ω)
R112	7030005040	S.RESISTOR	ERJ2GEJ 472 X (4.7 kΩ)
R113	7030007270	S.RESISTOR	ERJ2GEJ 151 X (150 Ω)
R114	7030007280	S.RESISTOR	ERJ2GEJ 331 X (330 Ω)
R151	7030005220	S.RESISTOR	ERJ2GEJ 223 X (22 kΩ)
R152	7030007290	S.RESISTOR	ERJ2GEJ 222 X (2.2 kΩ)
R153	7030007570	S.RESISTOR	ERJ2GEJ 122X (1.2 kΩ)
R154	7030005120	S.RESISTOR	ERJ2GEJ 102 X (1 kΩ)
R155	7030005720	S.RESISTOR	ERJ2GEJ 563 X (56 kΩ)
R156	7030007340	S.RESISTOR	ERJ2GEJ 153 X (1.5 kΩ)
R158	7030005110	S.RESISTOR	ERJ2GEJ 224 X (220 kΩ)
R159	7030005040	S.RESISTOR	ERJ2GEJ 472 X (4.7 kΩ)
R161	7030008010	S.RESISTOR	ERJ2GEJ 123 X (12 kΩ)
R162	7030005040	S.RESISTOR	ERJ2GEJ 472 X (4.7 kΩ)
R163	7030008010	S.RESISTOR	ERJ2GEJ 123 X (12 kΩ)
R164	7030008010	S.RESISTOR	ERJ2GEJ 123 X (12 kΩ)
R165	7030008010	S.RESISTOR	ERJ2GEJ 123 X (12 kΩ)
R166	7030008010	S.RESISTOR	ERJ2GEJ 123 X (12 kΩ)
R167	7030005110	S.RESISTOR	ERJ2GEJ 224 X (220 kΩ)
R201	7030005000	S.RESISTOR	ERJ2GEJ 471 X (470 Ω)
R202	7030005230	S.RESISTOR	ERJ2GEJ 334 X (330 kΩ)
R203	7030009280	S.RESISTOR	ERJ2GE
R204	7030005050	S.RESISTOR	ERJ2GEJ 103 X (10 kΩ)
R205	7030005240	S.RESISTOR	ERJ2GEJ 473 X (47 kΩ)
R206	7030005160	S.RESISTOR	ERJ2GEJ 105 X (1 MΩ)
R207	7030005110	S.RESISTOR	ERJ2GEJ 224 X (220 kΩ)
R208	7030005220	S.RESISTOR	ERJ2GEJ 223 X (22 kΩ)
R209	7030005030	S.RESISTOR	ERJ2GEJ 152 X (1.5 kΩ)
R210	7030004980	S.RESISTOR	ERJ2GEJ 101 X (100 Ω)
R211	7030005060	S.RESISTOR	ERJ2GEJ 333 X (33 kΩ)
R212	7030007290	S.RESISTOR	ERJ2GEJ 222 X (2.2 kΩ)
R213	7030005040	S.RESISTOR	ERJ2GEJ 472 X (4.7 kΩ)
R214	7030005040	S.RESISTOR	ERJ2GEJ 472 X (4.7 kΩ)
R215	7030008290	S.RESISTOR	ERJ2GEJ 183 X (1.8 kΩ)

S.=Surface mount

## [AF UNIT]

REF NO.	ORDER NO.	DESCRIPTION	
R216	7030008290	S.RESISTOR	ERJ2GEJ 183 X (18 kΩ)
R217	7030008290	S.RESISTOR	ERJ2GEJ 183 X (18 kΩ)
R218	7030005050	S.RESISTOR	ERJ2GEJ 103 X (10 kΩ)
R219	7030008290	S.RESISTOR	ERJ2GEJ 183 X (18 kΩ)
R220	7030005090	S.RESISTOR	ERJ2GEJ 104 X (100 kΩ)
R221	7030005050	S.RESISTOR	ERJ2GEJ 103 X (10 kΩ)
R222	7030008300	S.RESISTOR	ERJ2GEJ 184 X (180 kΩ)
R223	7030005160	S.RESISTOR	ERJ2GEJ 105 X (1 MΩ)
R224	7030005240	S.RESISTOR	ERJ2GEJ 473 X (47 kΩ)
R225	7030007340	S.RESISTOR	ERJ2GEJ 153 X (15 kΩ)
R228	7030008300	S.RESISTOR	ERJ2GEJ 184 X (180 kΩ)
R229	7030009160	S.RESISTOR	ERJ2GEJ 181 X (180 Ω)
R230	7030005530	S.RESISTOR	ERJ2GEJ 100 X (10 Ω)
R231	7030005120	S.RESISTOR	ERJ2GEJ 102 X (1 kΩ)
R232	7030007290	S.RESISTOR	ERJ2GEJ 222 X (2.2 kΩ)
R233	7030005050	S.RESISTOR	ERJ2GEJ 103 X (10 kΩ)
R234	7030005050	S.RESISTOR	ERJ2GEJ 103 X (10 kΩ)
R251	7030005160	S.RESISTOR	ERJ2GEJ 105 X (1 MΩ)
R252	7030005240	S.RESISTOR	ERJ2GEJ 473 X (47 kΩ)
R253	7030005060	S.RESISTOR	ERJ2GEJ 333 X (33 kΩ)
R254	7030005110	S.RESISTOR	ERJ2GEJ 224 X (220 kΩ)
R256	7030007340	S.RESISTOR	ERJ2GEJ 153 X (15 kΩ)
R257	7030005070	S.RESISTOR	ERJ2GEJ 683 X (68 kΩ)
R258	7030005080	S.RESISTOR	ERJ2GEJ 823 X (82 kΩ)
R259	7030005210	S.RESISTOR	ERJ2GEJ 822 X (8.2 kΩ)
R260	7030005310	S.RESISTOR	ERJ2GEJ 124 X (120 kΩ)
R261	7030005060	S.RESISTOR	ERJ2GEJ 333 X (33 kΩ)
R262	7030005040	S.RESISTOR	ERJ2GEJ 472 X (4.7 kΩ)
R263	7030007270	S.RESISTOR	ERJ2GEJ 151 X (150 Ω)
R264	7030005530	S.RESISTOR	ERJ2GEJ 100 X (10 Ω)
R265	7030007280	S.RESISTOR	ERJ2GEJ 331 X (330 Ω)
R266	7030008280	S.RESISTOR	ERJ2GEJ 271 X (270 Ω)
C1	4030017460	S.CERAMIC	ECJ0EB1E102K
C2	4030017460	S.CERAMIC	ECJ0EB1E102K
C3	4030017460	S.CERAMIC	ECJ0EB1E102K
C4	4030016790	S.CERAMIC	ECJ0EB1C103K
C5	4030017710	S.CERAMIC	ECJ0EC1H181J
C6	4030017690	S.CERAMIC	ECJ0EC1H121J
C7	4030017430	S.CERAMIC	ECJ0EC1H101J
C8	4030017600	S.CERAMIC	ECJ0EC1H080C
C9	4030016790	S.CERAMIC	ECJ0EB1C103K
C10	4030017570	S.CERAMIC	ECJ0EC1H040B
C11	4030017400	S.CERAMIC	ECJ0EC1H220J
C12	4030017350	S.CERAMIC	ECJ0EC1H020B
C13	4030017400	S.CERAMIC	ECJ0EC1H220J
C14	4030017570	S.CERAMIC	ECJ0EC1H040B
C17	4030017460	S.CERAMIC	ECJ0EB1E102K
C18	4030016790	S.CERAMIC	ECJ0EB1C103K
C23	4030017590	S.CERAMIC	ECJ0EC1H070C
C24	4030017660	S.CERAMIC	ECJ0EC1H330J
C25	4030017580	S.CERAMIC	ECJ0EC1H060C
C26	4030017660	S.CERAMIC	ECJ0EC1H330J
C51	4030017460	S.CERAMIC	ECJ0EB1E102K
C52	4030017460	S.CERAMIC	ECJ0EB1E102K
C53	4030017460	S.CERAMIC	ECJ0EB1E102K
C54	4550006620	S.TANTALUM	ECST0JY226R
C55	4030017460	S.CERAMIC	ECJ0EB1E102K
C56	4030017460	S.CERAMIC	ECJ0EB1E102K
C57	4030017460	S.CERAMIC	ECJ0EB1E102K
C58	4550006620	S.TANTALUM	ECST0JY226R
C59	4550006620	S.TANTALUM	ECST0JY226R
C60	4030017460	S.CERAMIC	ECJ0EB1E102K
C101	4030016790	S.CERAMIC	ECJ0EB1C103K
C103	4030017570	S.CERAMIC	ECJ0EC1H040B
C105	4030016790	S.CERAMIC	ECJ0EB1C103K
C107	4030017460	S.CERAMIC	ECJ0EB1E102K
C109	4030017430	S.CERAMIC	ECJ0EC1H101J
C110	4030017460	S.CERAMIC	ECJ0EB1E102K
C111	4030017460	S.CERAMIC	ECJ0EB1E102K
C113	4030016790	S.CERAMIC	ECJ0EB1C103K
C114	4030017600	S.CERAMIC	ECJ0EC1H080C
C115	4030017460	S.CERAMIC	ECJ0EB1E102K
C116	4030016790	S.CERAMIC	ECJ0EB1C103K
C117	4550006200	S.TANTALUM	ECST0JY106R
C151	4030017460	S.CERAMIC	ECJ0EB1E102K
C152	4030017330	S.CERAMIC	ECJ0EF1C104Z
C153	4030016790	S.CERAMIC	ECJ0EB1C103K
C154	4030017670	S.CERAMIC	ECJ0EC1H390J
C155	4030017700	S.CERAMIC	ECJ0EC1H151J
C156	4030017460	S.CERAMIC	ECJ0EB1E102K

## [AF UNIT]

REF NO.	ORDER NO.	DESCRIPTION	
C157	4030017460	S.CERAMIC	ECJ0EB1E102K
C158	4030017460	S.CERAMIC	ECJ0EB1E102K
C159	4030017330	S.CERAMIC	ECJ0EF1C104Z
C160	4030017460	S.CERAMIC	ECJ0EB1E102K
C161	4030017460	S.CERAMIC	ECJ0EB1E102K
C162	4030017330	S.CERAMIC	ECJ0EF1C104Z
C163	4030017330	S.CERAMIC	ECJ0EF1C104Z
C164	4550006200	S.TANTALUM	ECST0JY106R
C165	4030016790	S.CERAMIC	ECJ0EB1C103K
C166	4030016790	S.CERAMIC	ECJ0EB1C103K
C167	4030016790	S.CERAMIC	ECJ0EB1C103K
C168	4550006620	S.TANTALUM	ECST0JY226R
C201	4030017400	S.CERAMIC	ECJ0EC1H220J
C202	4030017460	S.CERAMIC	ECJ0EB1E102K
C203	4030016790	S.CERAMIC	ECJ0EB1C103K
C204	4030012610	S.CERAMIC	C2012 JB 1C 474K-T
C205	4550005980	S.TANTALUM	TEMSVA 1A 475M-8L
C206	4030017330	S.CERAMIC	ECJ0EF1C104Z
C207	4030009660	S.CERAMIC	C1608 JF 1C 224Z-T
C208	4030016790	S.CERAMIC	ECJ0EB1C103K
C209	4030017330	S.CERAMIC	ECJ0EF1C104Z
C210	4030017330	S.CERAMIC	ECJ0EF1C104Z
C211	4030017330	S.CERAMIC	ECJ0EF1C104Z
C212	4030016950	S.CERAMIC	ECJ0EB1A473K
C213	4030017780	S.CERAMIC	ECJ0EB1E472K
C214	4030016790	S.CERAMIC	ECJ0EB1C103K
C215	4030017780	S.CERAMIC	ECJ0EB1E472K
C216	4030017760	S.CERAMIC	ECJ0EB1H222K
C217	4030016790	S.CERAMIC	ECJ0EB1C103K
C218	4030016960	S.CERAMIC	ECJ0EB1C183K
C219	4030017330	S.CERAMIC	ECJ0EF1C104Z
C220	4030017330	S.CERAMIC	ECJ0EF1C104Z
C221	4030017330	S.CERAMIC	ECJ0EF1C104Z
C223	4030017330	S.CERAMIC	ECJ0EF1C104Z
C225	4030017490	S.CERAMIC	C1608 JB 1A 105K-T
C227	4030017460	S.CERAMIC	ECJ0EB1E102K
C228	4550006620	S.TANTALUM	ECST0JY226R
C229	4030017460	S.CERAMIC	ECJ0EB1E102K
C230	4030017460	S.CERAMIC	ECJ0EB1E102K
C251	4030017460	S.CERAMIC	ECJ0EB1E102K
C252	4030016950	S.CERAMIC	ECJ0EB1A473K
C253	4030017330	S.CERAMIC	ECJ0EF1C104Z
C254	4030017330	S.CERAMIC	ECJ0EF1C104Z
C255	4030017460	S.CERAMIC	ECJ0EB1E102K
C256	4030017330	S.CERAMIC	ECJ0EF1C104Z
C257	4030017460	S.CERAMIC	ECJ0EB1E102K
C258	4030017330	S.CERAMIC	ECJ0EF1C104Z
C259	4030008680	S.CERAMIC	C2012 JF 1C 105Z-T
C260	4030008680	S.CERAMIC	C2012 JF 1C 105Z-T
C261	4510006960	S.ELECTROLYTIC	ECEV0JA151WP
C263	4030017330	S.CERAMIC	ECJ0EF1C104Z
C265	4030017420	S.CERAMIC	ECJ0EC1H470J
C267	4550003080	S.TANTALUM	TEMSVA 1A 335M-8L
C268	4030016950	S.CERAMIC	ECJ0EB1A473K
C269	4510006960	S.ELECTROLYTIC	ECEV0JA151WP
C270	4030017460	S.CERAMIC	ECJ0EB1E102K
C272	4030017460	S.CERAMIC	ECJ0EB1E102K
C274	4030017420	S.CERAMIC	ECJ0EC1H470J
C275	4030017460	S.CERAMIC	ECJ0EB1E102K
C276	4030017460	S.CERAMIC	ECJ0EB1E102K
C277	4030017460	S.CERAMIC	ECJ0EB1E102K
C278	4030017460	S.CERAMIC	ECJ0EB1E102K
C279	4030017460	S.CERAMIC	ECJ0EB1E102K
C282	4030017420	S.CERAMIC	ECJ0EC1H470J
C283	4030017420	S.CERAMIC	ECJ0EC1H470J
C284	4030017420	S.CERAMIC	ECJ0EC1H470J
C286	4030017690	S.CERAMIC	ECJ0EC1H121J
C287	4030017420	S.CERAMIC	ECJ0EC1H470J
C289	4030017460	S.CERAMIC	ECJ0EB1E102K
C293	4030017420	S.CERAMIC	ECJ0EC1H470J
C296	4030017460	S.CERAMIC	ECJ0EB1E102K
C298	4030017330	S.CERAMIC	ECJ0EF1C104Z
C299	4030017330	S.CERAMIC	ECJ0EF1C104Z
C300	4030017330	S.CERAMIC	ECJ0EF1C104Z
C301	4030017330	S.CERAMIC	ECJ0EF1C104Z
C302	4030017460	S.CERAMIC	ECJ0EB1E102K
C303	4030017460	S.CERAMIC	ECJ0EB1E102K
C304	4030017460	S.CERAMIC	ECJ0EB1E102K
J51	6510022880	S.CONNECTOR	AXK5S30340P
J251	6510022470	S.CONNECTOR	40FLT-SM1-TB

S.=Surface mount

[AF UNIT]

REF NO.	ORDER NO.	DESCRIPTION	
J252	6450001680	CONNECTOR	HSJ1122-010010
J253	6450002250	CONNECTOR	HSJ1456-010320
S251	7600000210	ENCODER	TP70N00E20-15F-1903
W1	7030010040	S.JUMPER	ERJ2GE-JPW
W2	7030010040	S.JUMPER	ERJ2GE-JPW
W3	9014505003	WIRE	22/07/070/W02/W02
EP1	0910054435	PCB	B 5735E
EP3	6910012350	S.BEAD	MMZ1608Y 102BT
EP4	6910012350	S.BEAD	MMZ1608Y 102BT
EP5	6910012350	S.BEAD	MMZ1608Y 102BT
EP6	6910013310	S.BEAD	MMZ1608D121B
EP7	6910013310	S.BEAD	MMZ1608D121B
EP8	6910013310	S.BEAD	MMZ1608D121B

[LOGIC UNIT]

REF NO.	ORDER NO.	DESCRIPTION	
D141	1790001250	S.DIODE	MA2S111-(TX)
D143	1790001250	S.DIODE	MA2S111-(TX)
D152	1790001250	S.DIODE	MA2S111-(TX)
D253	1790001250	S.DIODE	MA2S111-(TX)
D300	1790001560	S.DIODE	1SS372 (TE85R)
D301	1790001560	S.DIODE	1SS372 (TE85R)
D302	1790001560	S.DIODE	1SS372 (TE85R)
X1	6050011080	S.XTAL	CR-687 (6.7584 MHz)
L24	6200003640	S.COIL	MLF1608E 100K-T
L140	6200003640	S.COIL	MLF1608E 100K-T
R1	7510001660	S.THRMISTOR	NTCG16 4LH 473KT
R2	7030005090	S.RESISTOR	ERJ2GEJ 104 X (100 kΩ)
R4	7030008280	S.RESISTOR	ERJ2GEJ 271 X (270 Ω)
R5	7030008280	S.RESISTOR	ERJ2GEJ 271 X (270 Ω)
R8	7030005240	S.RESISTOR	ERJ2GEJ 473 X (47 kΩ)
R9	7030005310	S.RESISTOR	ERJ2GEJ 124 X (120 kΩ)
R10	7030005050	S.RESISTOR	ERJ2GEJ 103 X (10 kΩ)
R11	7030000150	S.RESISTOR	MCR10EZHJ 12 Ω (120)
R12	7030005240	S.RESISTOR	ERJ2GEJ 473 X (47 kΩ)
R13	7030005240	S.RESISTOR	ERJ2GEJ 473 X (47 kΩ)
R14	7030005240	S.RESISTOR	ERJ2GEJ 473 X (47 kΩ)
R15	7030000150	S.RESISTOR	MCR10EZHJ 12 Ω (120)
R16	7030005120	S.RESISTOR	ERJ2GEJ 102 X (1 kΩ)
R17	7030005120	S.RESISTOR	ERJ2GEJ 102 X (1 kΩ)
R18	7030010390	S.RESISTOR	ERA3YED 821V
R19	7030005050	S.RESISTOR	ERJ2GEJ 103 X (10 kΩ)
R20	7030010370	S.RESISTOR	ERJ2RHD 561 X (560 Ω)
R21	7030005120	S.RESISTOR	ERJ2GEJ 102 X (1 kΩ)
R22	7030004980	S.RESISTOR	ERJ2GEJ 101 X (100 Ω)
R23	7030005120	S.RESISTOR	ERJ2GEJ 102 X (1 kΩ)
R24	7030004980	S.RESISTOR	ERJ2GEJ 101 X (100 Ω)
R27	7030005240	S.RESISTOR	ERJ2GEJ 473 X (47 kΩ)
R28	7030005120	S.RESISTOR	ERJ2GEJ 102 X (1 kΩ)
R29	7030010380	S.RESISTOR	ERJ2RHD 471 X (470 Ω)
R32	7030004980	S.RESISTOR	ERJ2GEJ 101 X (100 Ω)
R33	7030005120	S.RESISTOR	ERJ2GEJ 102 X (1 kΩ)
R34	7030004980	S.RESISTOR	ERJ2GEJ 101 X (100 Ω)
R35	7030005120	S.RESISTOR	ERJ2GEJ 102 X (1 kΩ)
R38	7030005090	S.RESISTOR	ERJ2GEJ 104 X (100 kΩ)
R39	7030005240	S.RESISTOR	ERJ2GEJ 473 X (47 kΩ)
R40	7030008010	S.RESISTOR	ERJ2GEJ 123 X (12 kΩ)
R42	7030005010	S.RESISTOR	ERJ2GEJ 681 X (680 Ω)
R43	7030009160	S.RESISTOR	ERJ2GEJ 181 X (180 Ω)
R46	7030005710	S.RESISTOR	ERJ2GEJ 121 X (120 Ω)
R47	7030005710	S.RESISTOR	ERJ2GEJ 121 X (120 Ω)
R51	7030005160	S.RESISTOR	ERJ2GEJ 105 X (1 MΩ)
R53	7030005070	S.RESISTOR	ERJ2GEJ 683 X (68 kΩ)
R54	7030005050	S.RESISTOR	ERJ2GEJ 103 X (10 kΩ)
R55	7030008270	S.RESISTOR	RR0510R-104-D (100 kΩ)
R56	7030005040	S.RESISTOR	ERJ2GEJ 472 X (4.7 kΩ)
R61	7030005010	S.RESISTOR	ERJ2GEJ 681 X (680 Ω)
R62	7030004990	S.RESISTOR	ERJ2GEJ 221 X (220 Ω)
R63	7030005010	S.RESISTOR	ERJ2GEJ 681 X (680 Ω)
R64	7030004990	S.RESISTOR	ERJ2GEJ 221 X (220 Ω)
R65	7030005010	S.RESISTOR	ERJ2GEJ 681 X (680 Ω)
R66	7030004990	S.RESISTOR	ERJ2GEJ 221 X (220 Ω)
R67	7030005010	S.RESISTOR	ERJ2GEJ 681 X (680 Ω)
R68	7030004990	S.RESISTOR	ERJ2GEJ 221 X (220 Ω)
R69	7030005010	S.RESISTOR	ERJ2GEJ 681 X (680 Ω)
R70	7030004990	S.RESISTOR	ERJ2GEJ 221 X (220 Ω)
R71	7030005010	S.RESISTOR	ERJ2GEJ 681 X (680 Ω)
R72	7030004990	S.RESISTOR	ERJ2GEJ 221 X (220 Ω)
R73	7030005010	S.RESISTOR	ERJ2GEJ 681 X (680 Ω)
R74	7030004990	S.RESISTOR	ERJ2GEJ 221 X (220 Ω)
R75	7030005040	S.RESISTOR	ERJ2GEJ 472 X (4.7 kΩ)
R80	7030005080	S.RESISTOR	ERJ2GEJ 823 X (82 kΩ)
R81	7030005080	S.RESISTOR	ERJ2GEJ 823 X (82 kΩ)
R82	7030005720	S.RESISTOR	ERJ2GEJ 563 X (56 kΩ)
R83	7030005720	S.RESISTOR	ERJ2GEJ 563 X (56 kΩ)
R84	7030005310	S.RESISTOR	ERJ2GEJ 124 X (120 kΩ)
R85	7030005050	S.RESISTOR	ERJ2GEJ 103 X (10 kΩ)
R88	7030005050	S.RESISTOR	ERJ2GEJ 103 X (10 kΩ)
R89	7030005240	S.RESISTOR	ERJ2GEJ 473 X (47 kΩ)
R91	7030005050	S.RESISTOR	ERJ2GEJ 103 X (10 kΩ)
R92	7030004970	S.RESISTOR	ERJ2GEJ 470 X (47 Ω)
R93	7030004970	S.RESISTOR	ERJ2GEJ 470 X (47 Ω)

[LOGIC UNIT]

REF NO.	ORDER NO.	DESCRIPTION	
IC1	1140010730	S.IC	M30220MA-116RP [USA]
	1140010710	S.IC	M30220MA-114RP except [USA]
IC2	1140009240	S.IC	HN58X24128FPI
IC5	1130006220	S.IC	TC4W53FU (TE12L)
IC91	1130007110	S.IC	TC7W04FU (TE12L)
IC92	1130007020	S.IC	TC7S66FU (TE85R)
IC141	1180002150	S.IC	NJM2370U32-TE1
IC142	1110005730	S.IC	S-80928CNMC
IC241	1110003800	S.IC	NJM2904V-TE1
Q1	1590001690	S.TRANSISTOR	UN9115 (TX)
Q2	1590001690	S.TRANSISTOR	UN9115 (TX)
Q3	1590001400	S.TRANSISTOR	XP1214 (TX)
Q4	1520000650	S.TRANSISTOR	2SB1201-S-TL
Q6	1590001400	S.TRANSISTOR	XP1214 (TX)
Q8	1520000460	S.TRANSISTOR	2SB1132 T100 R
Q9	1590001170	S.TRANSISTOR	XP1501-(TX) .AB
Q10	1540000350	S.TRANSISTOR	2SD2216-S (TX)
Q11	1590001140	S.TRANSISTOR	UN9210 (TX)
Q40	1590001860	S.TRANSISTOR	UN9215 (TX)
Q91	1540000350	S.TRANSISTOR	2SD2216-S (TX)
Q141	1540000350	S.TRANSISTOR	2SD2216-S (TX)
Q142	1590001170	S.TRANSISTOR	XP1501-(TX) .AB
Q145	1520000460	S.TRANSISTOR	2SB1132 T100 R
Q146	1590001170	S.TRANSISTOR	XP1501-(TX) .AB
Q147	1520000460	S.TRANSISTOR	2SB1132 T100 R
Q151	1540000350	S.TRANSISTOR	2SD2216-S (TX)
Q201	1520000650	S.TRANSISTOR	2SB1201-S-TL
Q202	1590001170	S.TRANSISTOR	XP1501-(TX) .AB
Q301	1590002380	S.TRANSISTOR	XP1115 (TX)
Q302	1520000430	S.TRANSISTOR	2SB1462-R (TX)
Q304	1550000010	S.FET	2SJ364-Q (TX)
Q305	1550000010	S.FET	2SJ364-Q (TX)
Q307	1590001440	S.TRANSISTOR	UN9214 (TX)
Q310	1590001190	S.TRANSISTOR	XP6501-(TX) .AB
Q311	1590001210	S.TRANSISTOR	XP5601-(TX) .AB
Q312	1590001190	S.TRANSISTOR	XP6501-(TX) .AB
Q342	1550000010	S.FET	2SJ364-Q (TX)
Q343	1550000010	S.FET	2SJ364-Q (TX)
Q451	1530002690	S.TRANSISTOR	2SC4116-GR (TE85R)
D5	1790000860	S.DIODE	MA133 (TX)
D6	1790000670	S.DIODE	SB07-03C-TB
D51	1790000820	S.DIODE	MA132K (TX) [USA], [CAN]
	1790000850	S.DIODE	MA132WK (TX) [GEN], [SEA]
D52	1790000820	S.DIODE	MA132K (TX)
D53	1790000850	S.DIODE	MA132WK (TX) except [GEN]
D56	1790001250	S.DIODE	MA2S111-(TX) except [GEN]
D58	1790001200	S.DIODE	MA6S121 (TX)
D60	1790001250	S.DIODE	MA2S111-(TX) [USA], [CAN] only
D91	1790001560	S.DIODE	1SS372 (TE85R)

S.=Surface mount

[LOGIC UNIT]

REF NO.	ORDER NO.	DESCRIPTION
R139	7030005530	S.RESISTOR ERJ2GEJ 100 X (10 Ω)
R140	7030005040	S.RESISTOR ERJ2GEJ 472 X (4.7 kΩ)
R141	7030007340	S.RESISTOR ERJ2GEJ 153 X (15 kΩ)
R142	7030005830	S.RESISTOR RR0510R-223-D (22 kΩ)
R143	7030005050	S.RESISTOR ERJ2GEJ 103 X (10 kΩ)
R144	7030005040	S.RESISTOR ERJ2GEJ 472 X (4.7 kΩ)
R145	7030005050	S.RESISTOR ERJ2GEJ 103 X (10 kΩ)
R146	7030005050	S.RESISTOR ERJ2GEJ 103 X (10 kΩ)
R147	7030005240	S.RESISTOR ERJ2GEJ 473 X (47 kΩ)
R148	7030008270	S.RESISTOR RR0510R-104-D (100 kΩ)
R149	7030005050	S.RESISTOR ERJ2GEJ 103 X (10 kΩ)
R151	7030005120	S.RESISTOR ERJ2GEJ 102 X (1 kΩ)
R152	7030005240	S.RESISTOR ERJ2GEJ 473 X (47 kΩ)
R153	7030005050	S.RESISTOR ERJ2GEJ 103 X (10 kΩ)
R154	7030005040	S.RESISTOR ERJ2GEJ 472 X (4.7 kΩ)
R203	7030000240	S.RESISTOR MCR10EZJH 68 Ω (680)
R204	7030000240	S.RESISTOR MCR10EZJH 68 Ω (680)
R205	7030000240	S.RESISTOR MCR10EZJH 68 Ω (680)
R207	7030005160	S.RESISTOR ERJ2GEJ 105 X (1 MΩ)
R208	7030005090	S.RESISTOR ERJ2GEJ 104 X (100 kΩ)
R209	7030005120	S.RESISTOR ERJ2GEJ 102 X (1 kΩ)
R210	7030008010	S.RESISTOR ERJ2GEJ 123 X (12 kΩ)
R211	7030005050	S.RESISTOR ERJ2GEJ 103 X (10 kΩ)
R241	7030005230	S.RESISTOR ERJ2GEJ 334 X (330 kΩ)
R243	7030005080	S.RESISTOR ERJ2GEJ 823 X (82 kΩ)
R244	7030005080	S.RESISTOR ERJ2GEJ 823 X (82 kΩ)
R245	7030005080	S.RESISTOR ERJ2GEJ 823 X (82 kΩ)
R246	7030005070	S.RESISTOR ERJ2GEJ 683 X (68 kΩ)
R247	7030005240	S.RESISTOR ERJ2GEJ 473 X (47 kΩ)
R248	7030005160	S.RESISTOR ERJ2GEJ 105 X (1 MΩ)
R249	7030005100	S.RESISTOR ERJ2GEJ 154 X (150 kΩ)
R301	7030009290	S.RESISTOR ERJ2GEJ 562 X (5.6 kΩ)
R302	7030007280	S.RESISTOR ERJ2GEJ 331 X (330 Ω)
R305	7030005290	S.RESISTOR ERJ2GEJ 682 X (6.8 kΩ)
R306	7030007290	S.RESISTOR ERJ2GEJ 222 X (2.2 kΩ)
R307	7030004980	S.RESISTOR ERJ2GEJ 101 X (100 Ω)
R308	7030005110	S.RESISTOR ERJ2GEJ 224 X (220 kΩ)
R309	7030005720	S.RESISTOR ERJ2GEJ 563 X (56 kΩ)
R310	7030008051	S.RESISTOR ERA3YKD 184V (180 kΩ)
R311	7030007300	S.RESISTOR ERJ2GEJ 332 X (3.3 kΩ)
R312	7030005710	S.RESISTOR ERJ2GEJ 121 X (120 Ω)
R313	7030007300	S.RESISTOR ERJ2GEJ 332 X (3.3 kΩ)
R314	7030005000	S.RESISTOR ERJ2GEJ 471 X (470 Ω)
R315	7030005461	S.RESISTOR ERA3YKD 204V (200 kΩ)
R316	7030005000	S.RESISTOR ERJ2GEJ 471 X (470 Ω)
R317	7030005110	S.RESISTOR ERJ2GEJ 224 X (220 kΩ)
R318	7030005120	S.RESISTOR ERJ2GEJ 102 X (1 kΩ)
R319	7030007290	S.RESISTOR ERJ2GEJ 222 X (2.2 kΩ)
R320	7030005060	S.RESISTOR ERJ2GEJ 333 X (33 kΩ)
R321	7030007340	S.RESISTOR ERJ2GEJ 153 X (15 kΩ)
R324	7030009290	S.RESISTOR ERJ2GEJ 562 X (5.6 kΩ)
R325	7310004660	S.TRIMMER EVM-2WSX80 B54 (503)
R326	7310004660	S.TRIMMER EVM-2WSX80 B54 (503)
R328	7030005170	S.RESISTOR ERJ2GEJ 474 X (470 kΩ)
R329	7030005170	S.RESISTOR ERJ2GEJ 474 X (470 kΩ)
R330	7030005120	S.RESISTOR ERJ2GEJ 102 X (1 kΩ)
R331	7030005210	S.RESISTOR ERJ2GEJ 822 X (8.2 kΩ)
R332	7030005080	S.RESISTOR ERJ2GEJ 823 X (82 kΩ)
R333	7030005830	S.RESISTOR RR0510R-223-D (22 kΩ)
R335	7030005120	S.RESISTOR ERJ2GEJ 102 X (1 kΩ)
R336	7030005050	S.RESISTOR ERJ2GEJ 103 X (10 kΩ)
R340	7030005070	S.RESISTOR ERJ2GEJ 683 X (68 kΩ)
R360	7030005050	S.RESISTOR ERJ2GEJ 103 X (10 kΩ)
R361	7030005240	S.RESISTOR ERJ2GEJ 473 X (47 kΩ)
R363	7030005530	S.RESISTOR ERJ2GEJ 100 X (10 Ω)
R364	7030005310	S.RESISTOR ERJ2GEJ 124 X (120 kΩ)
R365	7310004660	S.TRIMMER EVM-2WSX80 B54 (503)
R366	7310004660	S.TRIMMER EVM-2WSX80 B54 (503)
R367	7030005170	S.RESISTOR ERJ2GEJ 474 X (470 kΩ)
R368	7030005170	S.RESISTOR ERJ2GEJ 474 X (470 kΩ)
R400	7030005090	S.RESISTOR ERJ2GEJ 104 X (100 kΩ)
R451	7030008300	S.RESISTOR ERJ2GEJ 184 X (180 kΩ)
R452	7030005600	S.RESISTOR ERJ2GEJ 273 X (27 kΩ)
R453	7030005240	S.RESISTOR ERJ2GEJ 473 X (47 kΩ)
R454	7030005120	S.RESISTOR ERJ2GEJ 102 X (1 kΩ)
R455	7030005240	S.RESISTOR ERJ2GEJ 473 X (47 kΩ)
R456	7030005240	S.RESISTOR ERJ2GEJ 473 X (47 kΩ)
R457	7030005110	S.RESISTOR ERJ2GEJ 224 X (220 kΩ)
R458	7030005240	S.RESISTOR ERJ2GEJ 473 X (47 kΩ)
R459	7030005050	S.RESISTOR ERJ2GEJ 103 X (10 kΩ)
R460	7030007290	S.RESISTOR ERJ2GEJ 222 X (2.2 kΩ)

[LOGIC UNIT]

REF NO.	ORDER NO.	DESCRIPTION
C3	4030017640	S.CERAMIC ECJ0EC1H150J
C4	4030017390	S.CERAMIC ECJ0EC1H180J
C5	4030017460	S.CERAMIC ECJ0EB1E102K
C7	4030017460	S.CERAMIC ECJ0EB1E102K
C8	4030017330	S.CERAMIC ECJ0EF1C104Z
C9	4030017460	S.CERAMIC ECJ0EB1E102K
C10	4030016790	S.CERAMIC ECJ0EB1C103K
C11	4030016790	S.CERAMIC ECJ0EB1C103K
C12	4030016790	S.CERAMIC ECJ0EB1C103K
C13	4030017460	S.CERAMIC ECJ0EB1E102K
C14	4550006780	S.TANTALUM TEMSVB2 0J 476M-8R
C15	4030017440	S.CERAMIC ECJ0EC1H221J
C16	4030017780	S.CERAMIC ECJ0EB1E472K
C17	4030017760	S.CERAMIC ECJ0EB1H222K
C20	4030017400	S.CERAMIC ECJ0EC1H203K
C23	4030017500	S.CERAMIC ECJ0EC1H560J
C24	4030017420	S.CERAMIC ECJ0EC1H470J
C25	4030017460	S.CERAMIC ECJ0EB1E102K
C26	4030017460	S.CERAMIC ECJ0EB1E102K
C27	4030017420	S.CERAMIC ECJ0EC1H470J
C29	4030017420	S.CERAMIC ECJ0EC1H470J
C30	4030017420	S.CERAMIC ECJ0EC1H470J
C32	4030017460	S.CERAMIC ECJ0EB1E102K
C33	4030017420	S.CERAMIC ECJ0EC1H470J
C34	4030017460	S.CERAMIC ECJ0EB1E102K
C35	4030017420	S.CERAMIC ECJ0EC1H470J
C36	4030017420	S.CERAMIC ECJ0EC1H470J
C37	4030017420	S.CERAMIC ECJ0EC1H470J
C38	4030016790	S.CERAMIC ECJ0EB1C103K
C39	4030017420	S.CERAMIC ECJ0EC1H470J
C40	4030017390	S.CERAMIC ECJ0EC1H180J
C41	4030017460	S.CERAMIC ECJ0EB1E102K
C43	4030017460	S.CERAMIC ECJ0EB1E102K
C44	4030017460	S.CERAMIC ECJ0EB1E102K
C45	4030017460	S.CERAMIC ECJ0EB1E102K
C46	4030017460	S.CERAMIC ECJ0EB1E102K
C47	4030017460	S.CERAMIC ECJ0EB1E102K
C55	4030017460	S.CERAMIC ECJ0EB1E102K
C57	4030017460	S.CERAMIC ECJ0EB1E102K
C75	4550002980	S.TANTALUM TEMSVA 1C 225M-8L
C76	4030017460	S.CERAMIC ECJ0EB1E102K
C80	4550006960	S.TANTALUM TEMSVB2 0G 107M8R
C81	4030017460	S.CERAMIC ECJ0EB1E102K
C88	4030017510	S.CERAMIC ECJ0EC1H680J
C89	4030017460	S.CERAMIC ECJ0EB1E102K
C90	4030017460	S.CERAMIC ECJ0EB1E102K
C91	4030017460	S.CERAMIC ECJ0EB1E102K
C92	4030017460	S.CERAMIC ECJ0EB1E102K
C93	4030017460	S.CERAMIC ECJ0EB1E102K
C94	4030017330	S.CERAMIC ECJ0EF1C104Z
C95	4030008680	S.CERAMIC C2012 JF 1C 105Z-T
C96	4030008680	S.CERAMIC C2012 JF 1C 105Z-T
C97	4550006640	S.TANTALUM ECST1DY225R
C98	4030017330	S.CERAMIC ECJ0EF1C104Z
C99	4030008680	S.CERAMIC C2012 JF 1C 105Z-T
C101	4030017460	S.CERAMIC ECJ0EB1E102K
C102	4030017460	S.CERAMIC ECJ0EB1E102K
C103	4030017460	S.CERAMIC ECJ0EB1E102K
C138	4030017260	S.CERAMIC C2012 JB 0J 475KT
C139	4030017460	S.CERAMIC ECJ0EB1E102K
C140	4030017330	S.CERAMIC ECJ0EF1C104Z
C141	4030017460	S.CERAMIC ECJ0EB1E102K
C142	4550006780	S.TANTALUM TEMSVB2 0J 476M-8R
C143	4030017460	S.CERAMIC ECJ0EB1E102K
C145	4030017330	S.CERAMIC ECJ0EF1C104Z
C146	4030017330	S.CERAMIC ECJ0EF1C104Z
C147	4550006730	S.TANTALUM TEMSVB2 0J 226M-8L
C148	4030017460	S.CERAMIC ECJ0EB1E102K
C149	4550006780	S.TANTALUM TEMSVB2 0J 476M-8R
C150	4030016790	S.CERAMIC ECJ0EB1C103K
C151	4030017460	S.CERAMIC ECJ0EB1E102K
C152	4030016790	S.CERAMIC ECJ0EB1C103K
C153	4030017420	S.CERAMIC ECJ0EC1H470J
C154	4030017460	S.CERAMIC ECJ0EB1E102K
C162	4030017460	S.CERAMIC ECJ0EB1E102K
C198	4030017460	S.CERAMIC ECJ0EB1E102K
C199	4030017460	S.CERAMIC ECJ0EB1E102K
C200	4030017460	S.CERAMIC ECJ0EB1E102K
C205	4550006210	S.TANTALUM ECST1CX106R
C207	4030011810	S.CERAMIC C1608 JB 1A 224K-T
C208	4030017460	S.CERAMIC ECJ0EB1E102K
C209	4030017460	S.CERAMIC ECJ0EB1E102K

S.=Surface mount

**[LOGIC UNIT]**

REF NO.	ORDER NO.	DESCRIPTION	
C211	4550006140	S.TANTALUM	ECST1EY474R
C240	4030009980	S.CERAMIC	C1608 JB 1H 152K-T
C242	4030016940	S.CERAMIC	ECJ0EB1A393K
C243	4030017330	S.CERAMIC	ECJ0EF1C104Z
C244	4030016930	S.CERAMIC	ECJ0EB1A104K
C246	4030016930	S.CERAMIC	ECJ0EB1A104K
C247	4030017430	S.CERAMIC	ECJ0EC1H101J
C248	4550006150	S.TANTALUM	ECST1CY105R
C304	4030017430	S.CERAMIC	ECJ0EC1H101J
C305	4030017420	S.CERAMIC	ECJ0EC1H470J
C306	4550006620	S.TANTALUM	ECST0JY226R
C308	4030009630	S.CERAMIC	C1608 JB 1H 822K-T
C310	4030017420	S.CERAMIC	ECJ0EC1H470J
C311	4550005980	S.TANTALUM	TEMSVA 1A 475M-8L
C312	4030017460	S.CERAMIC	ECJ0EB1E102K
C313	4030017420	S.CERAMIC	ECJ0EC1H470J
C314	4030011810	S.CERAMIC	C1608 JB 1A 224K-T
C315	4030017460	S.CERAMIC	ECJ0EB1E102K
C316	4550005980	S.TANTALUM	TEMSVA 1A 475M-8L
C317	4030016950	S.CERAMIC	ECJ0EB1A473K
C318	4030016960	S.CERAMIC	ECJ0EB1C183K
C319	4030017420	S.CERAMIC	ECJ0EC1H470J
C320	4030017460	S.CERAMIC	ECJ0EB1E102K
C321	4030017460	S.CERAMIC	ECJ0EB1E102K
C323	4030017460	S.CERAMIC	ECJ0EB1E102K
C324	4030017460	S.CERAMIC	ECJ0EB1E102K
C325	4030017460	S.CERAMIC	ECJ0EB1E102K
C326	4030017460	S.CERAMIC	ECJ0EB1E102K
C340	4030017460	S.CERAMIC	ECJ0EB1E102K
C341	4030017460	S.CERAMIC	ECJ0EB1E102K
C347	4550006320	S.TANTALUM	ECST0JY475R
C348	4550006620	S.TANTALUM	ECST0JY226R
C400	4030008680	S.CERAMIC	C2012 JF 1C 105Z-T
C401	4030008680	S.CERAMIC	C2012 JF 1C 105Z-T
C402	4030008680	S.CERAMIC	C2012 JF 1C 105Z-T
C403	4030008680	S.CERAMIC	C2012 JF 1C 105Z-T
C404	4030008680	S.CERAMIC	C2012 JF 1C 105Z-T
C405	4030008680	S.CERAMIC	C2012 JF 1C 105Z-T
C451	4030016790	S.CERAMIC	ECJ0EB1C103K
C452	4030016790	S.CERAMIC	ECJ0EB1C103K
C453	4030017460	S.CERAMIC	ECJ0EB1E102K
C454	4030016930	S.CERAMIC	ECJ0EB1A104K
C455	4030009630	S.CERAMIC	C1608 JB 1H 822K-T
C456	4550006620	S.TANTALUM	ECST0JY226R
C919	4030016790	S.CERAMIC	ECJ0EB1C103K
C920	4030016790	S.CERAMIC	ECJ0EB1C103K
J1	6510022470	S.CONNECTOR	40FLT-SM1-TB
DS1	5010000160	S.LED	LNJ310M6URA
DS2	5010000160	S.LED	LNJ310M6URA
DS3	5010000150	S.LED	LT1EP53A
DS4	5030001990	LCD	TTR5169 UPFDHW
DS5	5040002670	S.LED	CL-165HR/YG
DS6	5040002670	S.LED	CL-165HR/YG
DS7	5040002670	S.LED	CL-165HR/YG
DS8	5040002670	S.LED	CL-165HR/YG
DS9	5040002670	S.LED	CL-165HR/YG
DS10	5040002670	S.LED	CL-165HR/YG
DS11	5040002670	S.LED	CL-165HR/YG
DS12	5040002670	S.LED	CL-165HR/YG
MC1	7700002310	MICROPHONE	EM-140
S401	2230001090	S.SWITCH	EVQPSH02K
S402	2230001090	S.SWITCH	EVQPSH02K
SP1	2510000840	SPEAKER	CS028014-12
W1	8900010520	CABLE	OPC-1033
W2	7120000470	JUMPER	ERDS2T0
W3	7030000010	S.JUMPER	MCR10EZJH JPW (000)
EP1	8930055190	LCD CONTACT	SRCN-2372-SP-N-W
EP2	0910054444	PCB	B 5736D

**[LOGIC UNIT]**

REF NO.	ORDER NO.	DESCRIPTION	
EP3	6910012350	S.BEAD	MMZ1608Y 102BT
EP141	6910012350	S.BEAD	MMZ1608Y 102BT
EP142	6910012350	S.BEAD	MMZ1608Y 102BT

**[VCO UNIT]**

REF NO.	ORDER NO.	DESCRIPTION	
IC1	1110004460	S.IC	µPB1509GV-E1
IC201	1130007610	S.IC	µPD3140GS-E1 (DS8)
Q1	1530003810	S.TRANSISTOR	2SC5008-T1
Q2	1530003810	S.TRANSISTOR	2SC5008-T1
Q3	1590001860	S.TRANSISTOR	UN9215 (TX)
Q4	1530003810	S.TRANSISTOR	2SC5008-T1
Q5	1530003810	S.TRANSISTOR	2SC5008-T1
Q7	1530003560	S.TRANSISTOR	2SC5195-T1
Q11	1530003310	S.TRANSISTOR	2SC5107-O (TE85R)
Q14	1590001660	S.TRANSISTOR	XP4312 (TX)
Q15	1590001470	S.TRANSISTOR	UN9213 (TX)
Q16	1530003810	S.TRANSISTOR	2SC5008-T1
Q206	1560000540	S.FET	2SK880-Y (TE85R)
Q207	1530003010	S.TRANSISTOR	2SC4117-GR (TE85R)
Q211	1530002600	S.TRANSISTOR	2SC4215-O (TE85R)
Q212	1530003810	S.TRANSISTOR	2SC5008-T1
D1	1720000790	S.VARICAP	HVC321B1TRF
D2	1790001260	S.DIODE	MA2S077-(TX)
D3	1720000790	S.VARICAP	HVC321B1TRF
D7	1750000800	S.DIODE	HVC136TRF
D8	1750000800	S.DIODE	HVC136TRF
D9	1750000800	S.DIODE	HVC136TRF
D10	1750000800	S.DIODE	HVC136TRF
L2	6200007760	S.COIL	LQW2BHN82NJ01L (LQN21A 82NJ04)
L3	6200004480	S.COIL	MLF1608D R82K-T
L4	6200010110	S.COIL	0.20-0.8-4TR 11N
L12	6200006980	S.COIL	ELJRE R10G-F
L13	6200007000	S.COIL	ELJRE 82NG-F
L201	6200003550	S.COIL	MLF1608A 4R7K-T
L202	6200003550	S.COIL	MLF1608A 4R7K-T
L203	6200006960	S.COIL	MLF1608A 2R7K-T
R1	7030005700	S.RESISTOR	ERJ2GEJ 274 X (270 kΩ)
R2	7030005120	S.RESISTOR	ERJ2GEJ 102 X (1 kΩ)
R3	7030009290	S.RESISTOR	ERJ2GEJ 562 X (5.6 kΩ)
R4	7030007270	S.RESISTOR	ERJ2GEJ 151 X (150 Ω)
R5	7030008400	S.RESISTOR	ERJ2GEJ 182 X (1.8 kΩ)
R6	7030009290	S.RESISTOR	ERJ2GEJ 562 X (5.6 kΩ)
R7	7030007270	S.RESISTOR	ERJ2GEJ 151 X (150 Ω)
R8	7030005300	S.RESISTOR	ERJ2GEJ 150 X (15 Ω)
R9	7030005700	S.RESISTOR	ERJ2GEJ 274 X (270 kΩ)
R10	7030004980	S.RESISTOR	ERJ2GEJ 101 X (100 Ω)
R11	7030005040	S.RESISTOR	ERJ2GEJ 472 X (4.7 kΩ)
R12	7030005710	S.RESISTOR	ERJ2GEJ 121 X (120 Ω)
R13	7030005120	S.RESISTOR	ERJ2GEJ 102 X (1 kΩ)
R14	7030005040	S.RESISTOR	ERJ2GEJ 472 X (4.7 kΩ)
R15	7030005710	S.RESISTOR	ERJ2GEJ 121 X (120 Ω)
R16	7030009320	S.RESISTOR	ERJ2GEJ 4R7 X (4.7 Ω)
R17	7030005060	S.RESISTOR	ERJ2GEJ 333 X (33 kΩ)
R18	7030004980	S.RESISTOR	ERJ2GEJ 101 X (100 Ω)
R19	7030005530	S.RESISTOR	ERJ2GEJ 100 X (10 Ω)
R33	7030005060	S.RESISTOR	ERJ2GEJ 333 X (33 kΩ)
R34	7030007270	S.RESISTOR	ERJ2GEJ 151 X (150 Ω)
R35	7030004970	S.RESISTOR	ERJ2GEJ 470 X (47 Ω)
R44	7030005120	S.RESISTOR	ERJ2GEJ 102 X (1 kΩ)
R45	7030005040	S.RESISTOR	ERJ2GEJ 472 X (4.7 kΩ)
R46	7030007570	S.RESISTOR	ERJ2GEJ 122X (1.2 kΩ)
R47	7030005040	S.RESISTOR	ERJ2GEJ 472 X (4.7 kΩ)
R48	7030004990	S.RESISTOR	ERJ2GEJ 221 X (220 Ω)
R49	7030008410	S.RESISTOR	ERJ2GEJ 392 X (3.9 kΩ)
R50	7030005040	S.RESISTOR	ERJ2GEJ 472 X (4.7 kΩ)
R51	7030007290	S.RESISTOR	ERJ2GEJ 222 X (2.2 kΩ)

S.=Surface mount

[VCO UNIT]

REF NO.	ORDER NO.	DESCRIPTION	
R52	7030007290	S.RESISTOR	ERJ2GEJ 222 X (2.2 kΩ)
R208	7030008250	S.RESISTOR	RR0510P-562-D (5.6 kΩ)
R211	7030005090	S.RESISTOR	ERJ2GEJ 104 X (100 kΩ)
R212	7030008410	S.RESISTOR	ERJ2GEJ 392 X (3.9 kΩ)
R213	7030008280	S.RESISTOR	ERJ2GEJ 271 X (270 Ω)
R215	7030006020	S.RESISTOR	RR0510P-682-D (6.8 kΩ)
R216	7030006030	S.RESISTOR	RR0510P-822-D (8.2 kΩ)
R217	7030006020	S.RESISTOR	RR0510P-682-D (6.8 kΩ)
R220	7030008250	S.RESISTOR	RR0510P-562-D (5.6 kΩ)
R228	7030005050	S.RESISTOR	ERJ2GEJ 103 X (10 kΩ)
R229	7030005120	S.RESISTOR	ERJ2GEJ 102 X (1 kΩ)
R230	7030005120	S.RESISTOR	ERJ2GEJ 102 X (1 kΩ)
R231	7030005120	S.RESISTOR	ERJ2GEJ 102 X (1 kΩ)
R232	7030004980	S.RESISTOR	ERJ2GEJ 101 X (100 Ω)
R233	7030005100	S.RESISTOR	ERJ2GEJ 154 X (150 kΩ)
R234	7030007270	S.RESISTOR	ERJ2GEJ 151 X (150 Ω)
R235	7030005040	S.RESISTOR	ERJ2GEJ 472 X (4.7 kΩ)
R236	7030007270	S.RESISTOR	ERJ2GEJ 151 X (150 Ω)
R238	7030007340	S.RESISTOR	ERJ2GEJ 153 X (15 kΩ)
R239	7030008280	S.RESISTOR	ERJ2GEJ 271 X (270 Ω)
R240	7030005050	S.RESISTOR	ERJ2GEJ 103 X (10 kΩ)
R241	7030004970	S.RESISTOR	ERJ2GEJ 470 X (47 Ω)
R242	7030007340	S.RESISTOR	ERJ2GEJ 153 X (15 kΩ)
R243	7030007270	S.RESISTOR	ERJ2GEJ 151 X (150 Ω)
R244	7030004980	S.RESISTOR	ERJ2GEJ 101 X (100 Ω)
C1	4030017640	S.CERAMIC	ECJ0EC1H150J
C2	4030017460	S.CERAMIC	ECJ0EB1E102K
C4	4030017350	S.CERAMIC	ECJ0EC1H020B
C5	4030017350	S.CERAMIC	ECJ0EC1H020B
C7	4030017460	S.CERAMIC	ECJ0EB1E102K
C8	4030016790	S.CERAMIC	ECJ0EB1C103K
C9	4030017530	S.CERAMIC	ECJ0EC1H0R5B
C10	4030016790	S.CERAMIC	ECJ0EB1C103K
C11	4030017460	S.CERAMIC	ECJ0EB1E102K
C12	4030017460	S.CERAMIC	ECJ0EB1E102K
C13	4030017690	S.CERAMIC	ECJ0EC1H121J
C16	4030017550	S.CERAMIC	ECJ0EC1H1R5B
C17	4030017550	S.CERAMIC	ECJ0EC1H1R5B
C19	4030017730	S.CERAMIC	ECJ0EB1E471K
C20	4030017460	S.CERAMIC	ECJ0EB1E102K
C21	4030017560	S.CERAMIC	ECJ0EC1H2R5B
C22	4030017460	S.CERAMIC	ECJ0EB1E102K
C23	4030017460	S.CERAMIC	ECJ0EB1E102K
C24	4030017460	S.CERAMIC	ECJ0EB1E102K
C25	4030017460	S.CERAMIC	ECJ0EB1E102K
C26	4030017460	S.CERAMIC	ECJ0EB1E102K
C39	4030017550	S.CERAMIC	ECJ0EC1H1R5B
C40	4030017460	S.CERAMIC	ECJ0EB1E102K
C41	4030017460	S.CERAMIC	ECJ0EB1E102K
C42	4030017460	S.CERAMIC	ECJ0EB1E102K
C48	4030017460	S.CERAMIC	ECJ0EB1E102K
C49	4030017590	S.CERAMIC	ECJ0EC1H070C
C50	4030017650	S.CERAMIC	ECJ0EC1H270J
C51	4030017420	S.CERAMIC	ECJ0EC1H470J
C59	4030016930	S.CERAMIC	ECJ0EB1A104K
C63	4030016790	S.CERAMIC	ECJ0EB1C103K
C64	4030017460	S.CERAMIC	ECJ0EB1E102K
C65	4030017460	S.CERAMIC	ECJ0EB1E102K
C66	4030017460	S.CERAMIC	ECJ0EB1E102K
C67	4030017460	S.CERAMIC	ECJ0EB1E102K
C207	4550000540	S.TANTALUM	TESVA 1V 154M1-8L
C209	4030017460	S.CERAMIC	ECJ0EB1E102K
C210	4030017330	S.CERAMIC	ECJ0EF1C104Z
C211	4030017460	S.CERAMIC	ECJ0EB1E102K
C212	4030017460	S.CERAMIC	ECJ0EB1E102K
C213	4340000280	S.MYLAR	ECPU 1C 473MA5
C214	4550007020	S.TANTALUM	ECST1AZ155R
C215	4550007020	S.TANTALUM	ECST1AZ155R
C219	4550006560	S.TANTALUM	ECST1CY225R
C221	4030017460	S.CERAMIC	ECJ0EB1E102K
C224	4030017460	S.CERAMIC	ECJ0EB1E102K
C225	4030017460	S.CERAMIC	ECJ0EB1E102K
C226	4030017460	S.CERAMIC	ECJ0EB1E102K
C228	4030017420	S.CERAMIC	ECJ0EC1H470J
C229	4030017420	S.CERAMIC	ECJ0EC1H470J
C230	4030017460	S.CERAMIC	ECJ0EB1E102K
C232	4030016930	S.CERAMIC	ECJ0EB1A104K
C233	4030017460	S.CERAMIC	ECJ0EB1E102K
C234	4030017660	S.CERAMIC	ECJ0EC1H330J
C235	4030017550	S.CERAMIC	ECJ0EC1H1R5B

[VCO UNIT]

REF NO.	ORDER NO.	DESCRIPTION	
C236	4030017460	S.CERAMIC	ECJ0EB1E102K
C237	4030017460	S.CERAMIC	ECJ0EB1E102K
C238	4550007040	S.TANTALUM	ECST0JZ106R
C239	4030017340	S.CERAMIC	ECJ0EC1H010B
J1	6910011530	CONNECTOR	IMSA-9230B-1-08Z057-T
J2	6910014430	CONNECTOR	IMSA-9230B-1-06Z057-T
W1	7030010040	S.JUMPER	ERJ2GE-JPW
EP1	0910054453	PCB	B 5737C
EP2	6910012350	S.BEAD	MMZ1608Y 102BT

S.=Surface mount



# SECTION 7 MECHANICAL PARTS AND DISASSEMBLY

## [CHASSIS PARTS]

REF NO.	ORDER NO.	DESCRIPTION	QTY.
J1	6510022671	Connector SMA-R235-1	1
MP1	8210018240	Panel 2507 REAR PANEL 63-222	1
MP2	8930054200	2372 Jack cap	1
MP3	8930056321	2507 DC cap-1	1
MP4	8310050390	2372 Lock plate	1
MP5	8610010990	Knob N284	1
MP6	8930054290	2372 main seal	1
MP8	8930054371	2372 Terminal spring-1	2
MP9	8930054580	Seal O-ring (AM)	1
MP10	8930054490	2372 shaft	1
MP11	8830001470	VR nut (N)	1
MP12	8930039850	Sealing washer (J)	3
MP14	8860001281	2507 antenna rug-1	1
MP15	8860001250	2372 vol rug Y587	1
MP17	8930053590	Seal O-ring (AG)	1
MP19	8830000880	VR nut (I)	1
MP20	8610007510	Knob spring NO.7800	1
MP21	8810009510	Screw PH BT M2x4 NI-ZU	3
MP22	8810008620	Screw PH BT M2x20 ZK 2	
MP23	8810010090	Screw PH BT M2x12 ZK 2	
MP24	8810009560	Screw PH BT M2x6 ZK	4
MP25	8810000100	Screw PH M2x4 ZK	1
MP26	8930055510	2372 Insulate sheet	1
MP27	8930058510	Isolating plate (HC)	1
MP28	8930058500	Isolating plate (HB)	1
MP29	8930058620	Isolating plate (HE)	1
MP30	8930058630	Isolating plate (HF)	1
MP31	8930058640	2507 PA sheet	1
MP32	8930058800	2507 plate [USA], [CAN] only	1
MP33	8930058800	2507 plate [USA], [CAN] only	1
MP34	8930058820	2507 A-plate [USA], [CAN] only	1

## [RF UNIT]

REF NO.	ORDER NO.	DESCRIPTION	QTY.
MP1	8930056310	2507 terminal holder	1
MP2	8510014590	2507 A-VCO case	1
MP5	8410002470	2507 heat sink	1
MP6	8510014410	2507 RF plate Y611	1
MP8	8930058060	Isolating plate (GZ)	1
MP9	8930058010	Sermary sheat (AF) TC-100TKC (5X7)	1
MP10	8930058070	2507 radiation plate	1
MP11	8930053900	Isolating plate (GK)	1
MP12	8930056030	Isolating plate (GS)	1
MP13	8930004081	Ground spring (B)-1	1
MP14	8930058540	2507 R-connect plate	1
MP15	8930058520	2507 L-connect plate	1
MP18	8930058530	2507 sheet	1
MP19	8930058810	2507 spring [USA], [CAN] only	1
MP20	8930058510	Isolating plate (HC)	1

## [VCO UNIT]

REF NO.	ORDER NO.	DESCRIPTION	QTY.
MP1	8930058300	Aluminium sheet (AF)	1
MP2	8930058610	Isolating plate (HD)	1

## [AF UNIT]

REF NO.	ORDER NO.	DESCRIPTION	QTY.
S251	7600000210	Encoder TP70N00E20-15F-1903	1
MP2	8930058200	2507 A-AF sheet	1
MP4	8510014850	2507 AF shield	1

## [LOGIC UNIT]

REF NO.	ORDER NO.	DESCRIPTION	QTY.
DS4	5030001990	LCD TTR5169 UPFDHW	1
EP1	8930055190	LCD contact SRCN-2372-SP-N-W	1
SP1	2510000840	Speaker CS028014-12	1
MC1	7700002310	Microphone EM-140	1
MP1	8210018351	2372 front panel(E)-1	1
MP2	8310050400	2372 window plate	1
MP3	8210017460	2372 reflector	1
MP4	8930054221	2372 lens-1	1
MP5	8930054570	870 Salan net (A)	1
MP6	8930054500	2372 window sheet	1
MP7	8930054940	2372 LCD sponge	1
MP8	8930054380	2372 PTT plate	1
MP9	8930048840	2135 MIC sponge	1
MP10	8930046020	1123 sheet (A)-1	1
MP11	8930054250	2372 10-KEY	1
MP12	8930055170	2372 tact plate	1
MP13	8810009510	Screw PH BT M2x4 NI-ZU 6	
MP14	8510013950	2372 LOGIC plate	1
MP15	8930058650	Isolating plate (HG)	1
W1	8900010520	Cable OPC-1033	1

## Screw abbreviations

BT: Self-tapping PH: Pan head NI-ZU: Nickel-Zinc ZK: Black

## [ACCESSORIES]

REF NO.	ORDER NO.	DESCRIPTION	QTY.
EP1	3310002950	Antenna FA-S6270D	1
EP2	0800005960	Battery BP-217 ACC	1
EP3	5930001220	Charger BP-110AR [USA], [CAN] only	1
	5930000950	Charger BC-110D [GEN] only	1
MP1	8010018080	Strap belt HK-009	1
MP2	0880001120	Clip MB-83 ACC	1

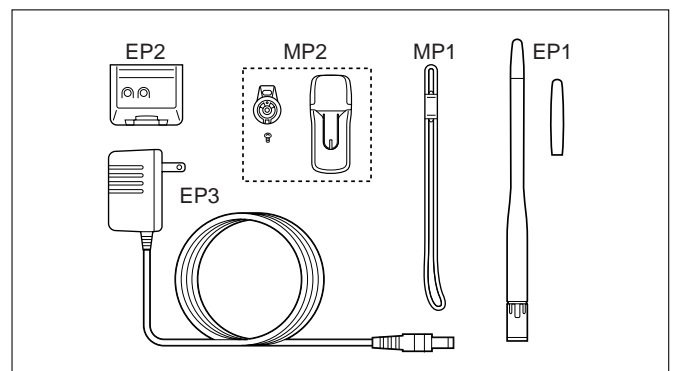

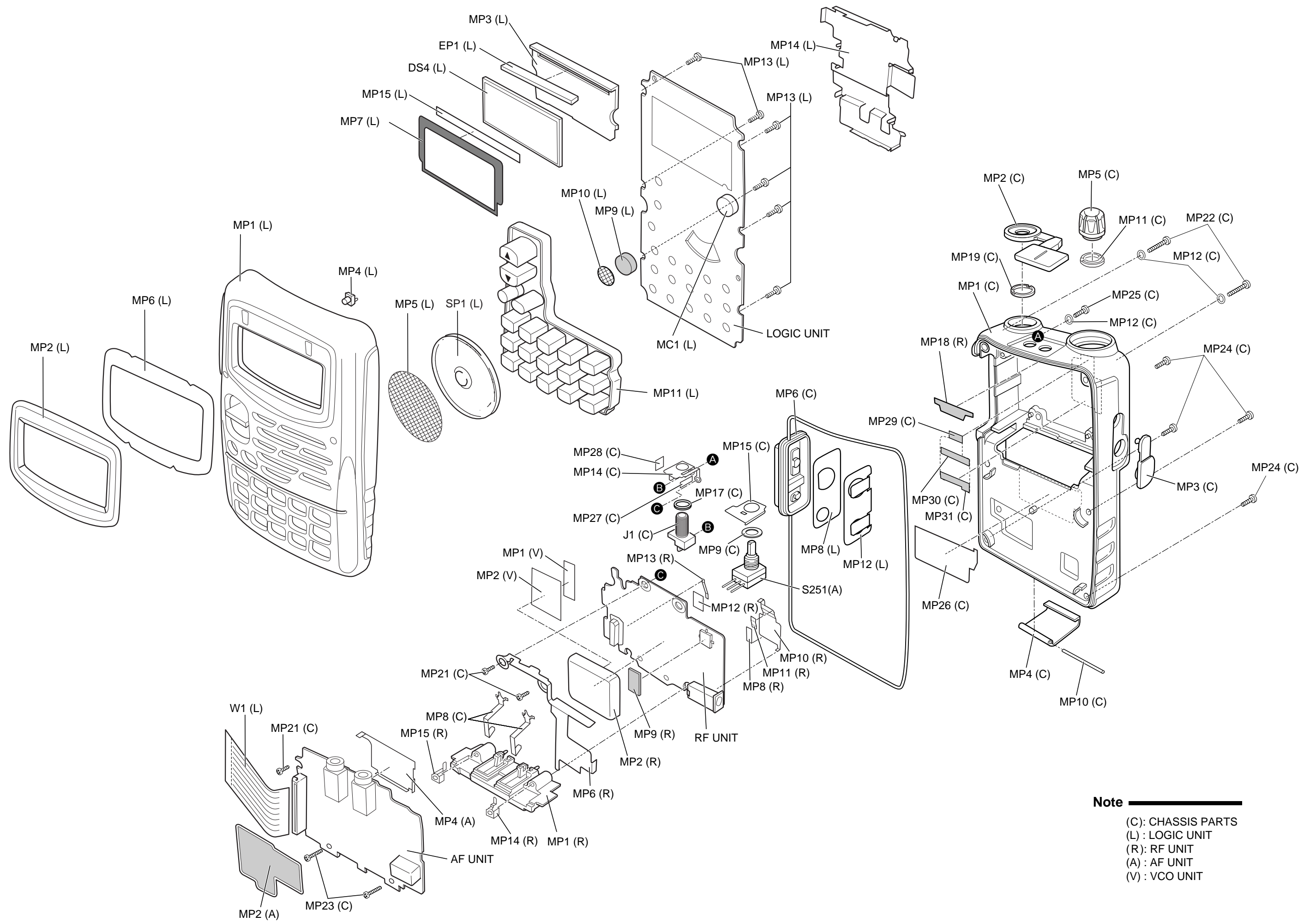

**Note**

- (C): CHASSIS PARTS
- (L): LOGIC UNIT
- (R): RF UNIT
- (A): AF UNIT
- (V): VCO UNIT

# SECTION 8 SEMI-CONDUCTOR INFORMATION

## 8 - 1 TRANSISTORS AND FETS

NAME	SYMBOL	INSIDE VIEW
2SA1576 S 2SA1588-GR 2SB1462-R	FS ZG AR	
2SB1132 R	BARB	
2SB1201-S-TL	B1201	
2SC4116-GR 2SC4117-GR 2SC4215-O 2SC4403-3-TL 2SC4406-4-TL 2SC5006-T1 2SC5008-T1 2SC5107-O 2SC5195-T1 2SD2216-S	LG DG QO LY3 JT 24 44 MFO 88 Y	
2SC5289-T1	T90	
2SC5508-T2 2SC5624VH-TL	T79 VH-	
2SJ364-Q	4MQ	
2SK880-Y	XY	

NAME	SYMBOL	INSIDE VIEW
2SK3475	WB	
2SK3476	TUCF	
3SK320	U7	
UN9113	6C	
UN9115	6E	
UN9210	8L	
UN9211 UN9213 UN9214 UN9215	8A 8C 8A 8E	
XP1115	9L	
XP1214	9H	
XP1501-AB	5R	

NAME	SYMBOL	INSIDE VIEW
XP4214	BR	
XP4312	7T	
XP4315 XP4316	CB 7U	
XP4601	5C	
XP5601-AB	4N	
XP6401	5O	
XP6501-AB	5N	
HAT1023R-EL	1023	

## 8 - 2 DIODES

NAME	SYMBOL	INSIDE VIEW
1SS362 1SS372 MA133	C3 N9 MP	
1SS364 MA132WK	BF MU	
1SV271 1SV290 1SV308 HVC132 HVC136 TRF HVC321 B1 TRF HVC376 B TRF MA2S077 MA2S111 MA2S728 RB060L-40	TG TJ TX P2 P6 V8 B9 S A B 36	
1SV307	TX	
MA132HK	M3N	
MA132K SB07-03C-TB	7N J	
MA6S121	M2D	

# SECTION 9 BOARD LAYOUTS

The combination of this page and the next page shows the unit layout in the same configuration as the actual P.C. Board.

## 9 - 1 LOGIC UNIT • TOP VIEW

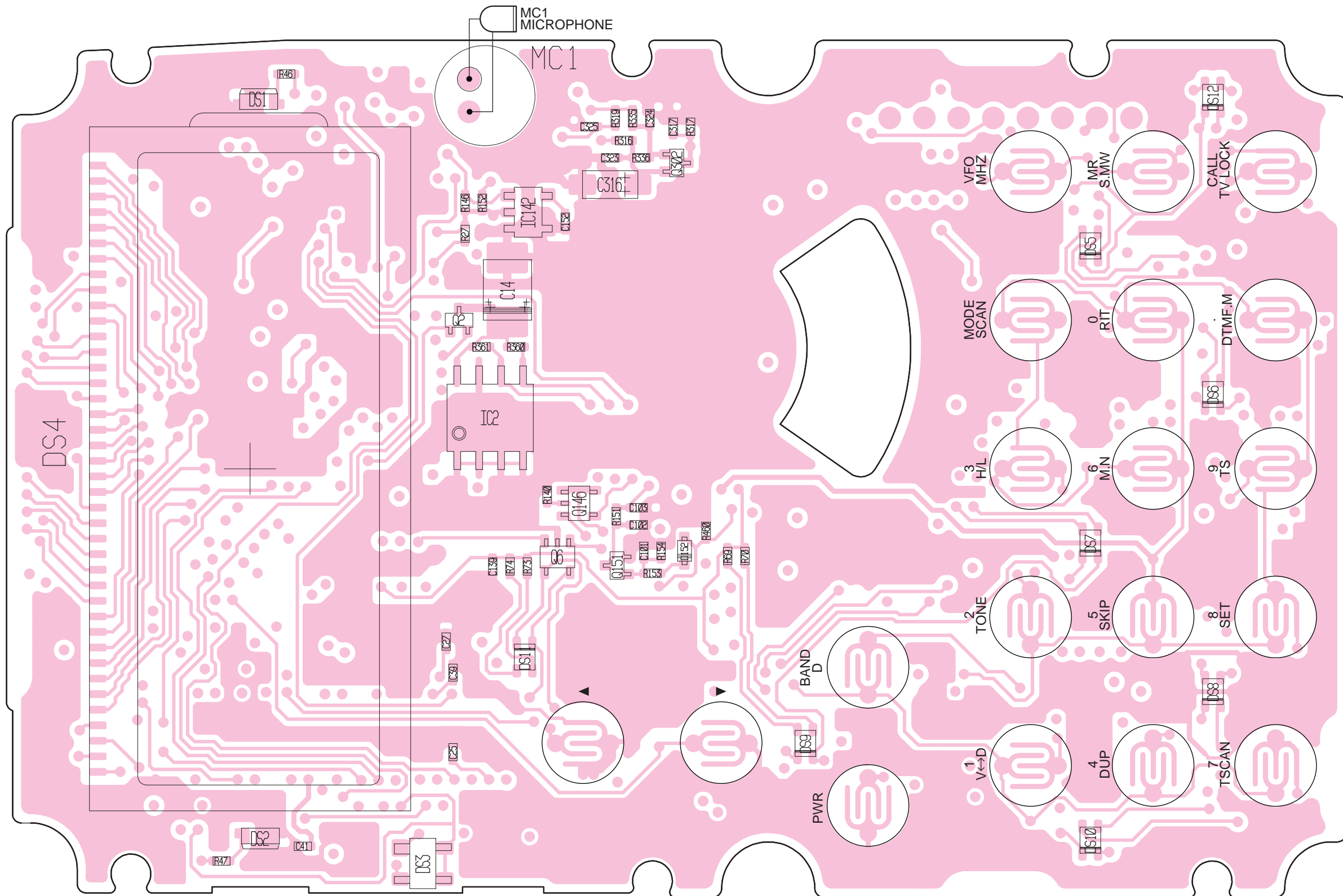



**9 - 2 RF UNIT**  
• TOP VIEW

The combination of this page and the next page shows the unit layout in the same configuration as the actual P.C. Board.

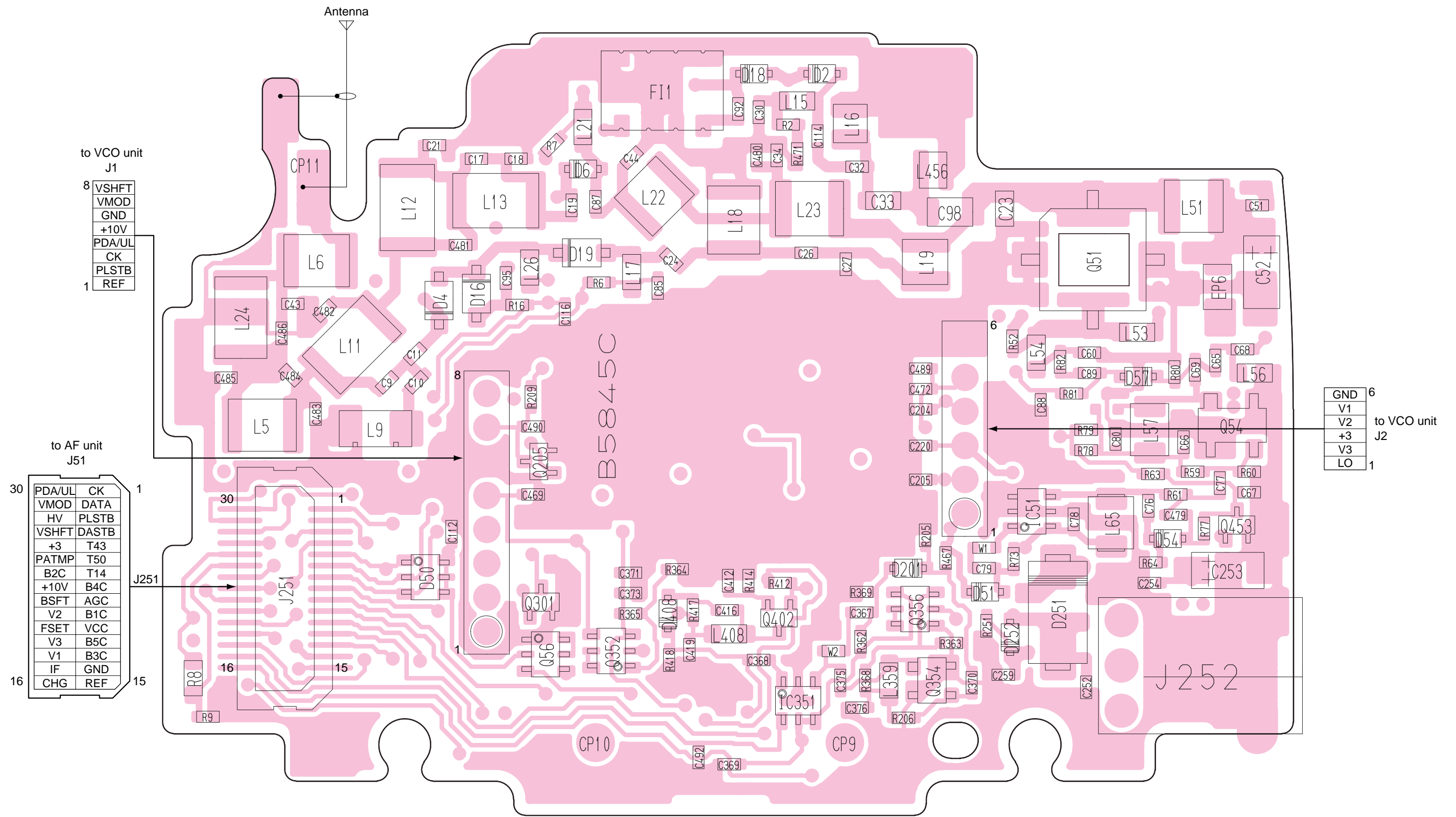

RF unit  
• BOTTOM VIEW

The combination of this page and the previous page shows the unit layout in the same configuration as the actual P.C. Board.

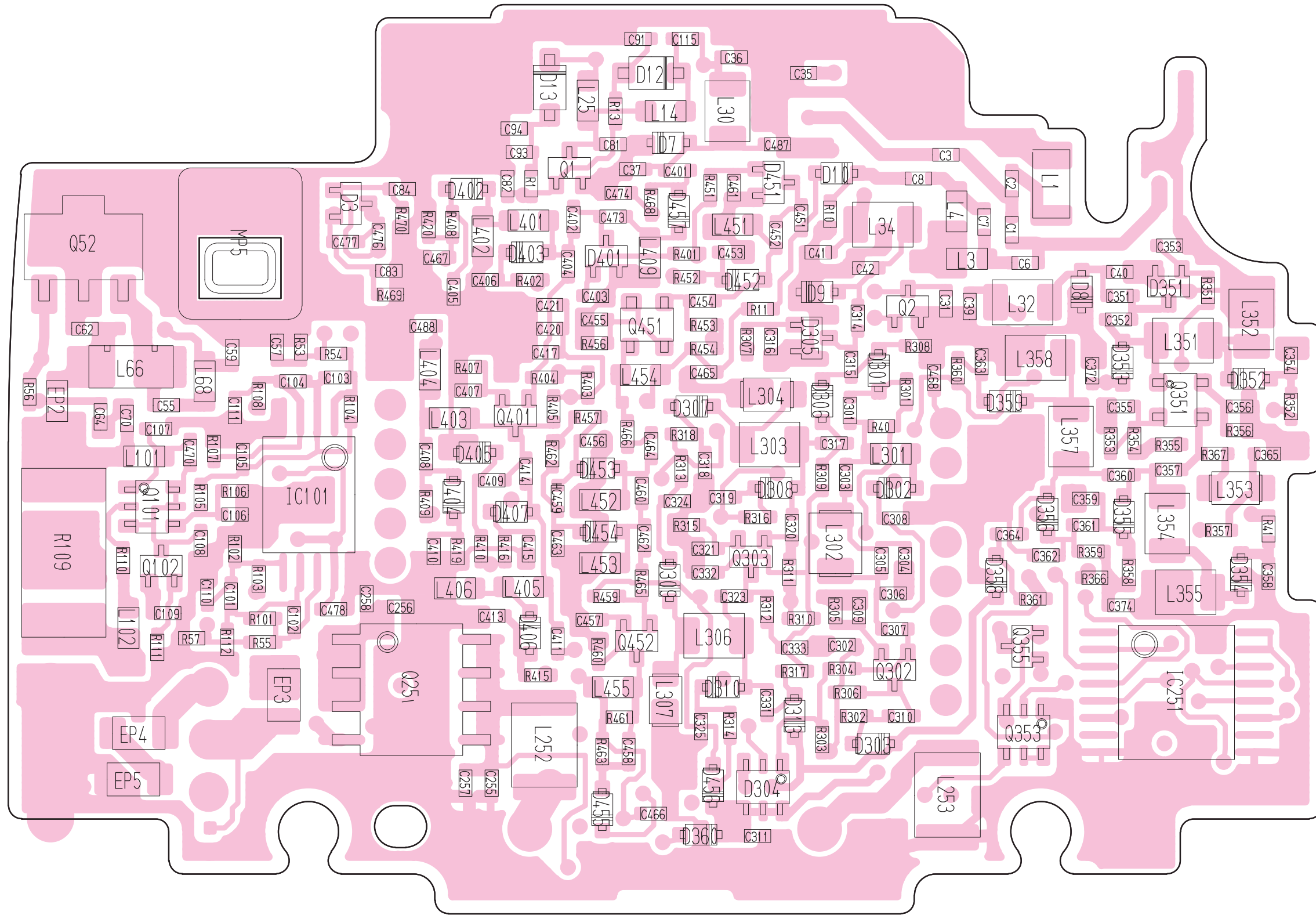

**9 - 3 AF UNIT**  
• TOP VIEW

The combination of this page and the next page shows the unit layout in the same configuration as the actual P.C. Board.

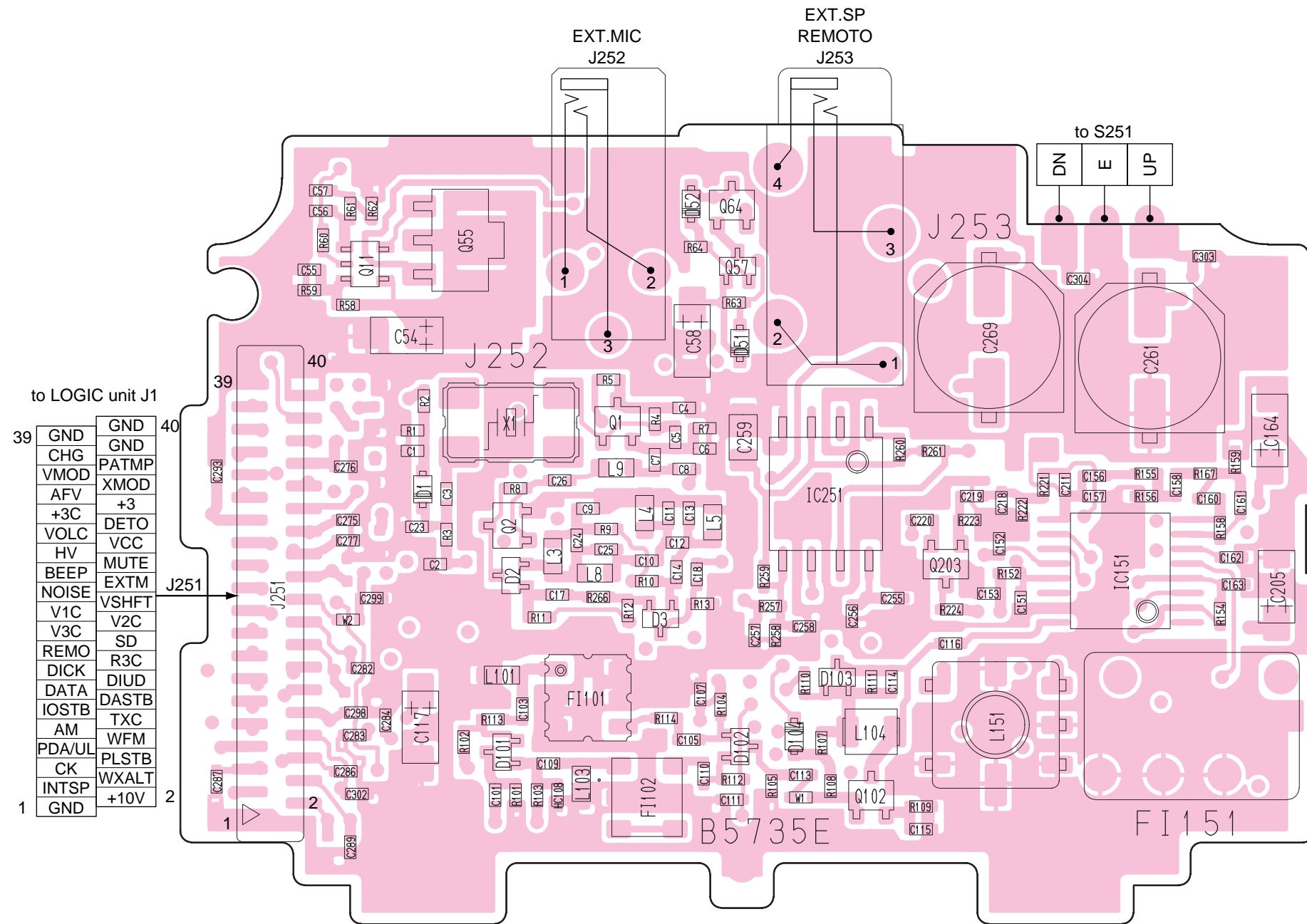

**VCO UNIT**  
• TOP VIEW

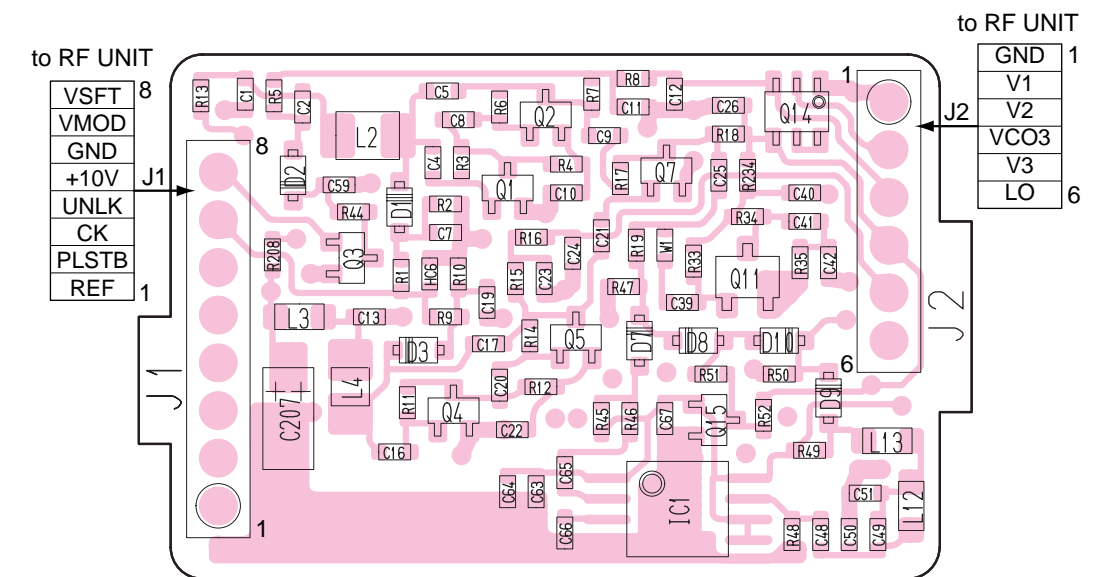



The combination of this page and the previous page shows the unit layout in the same configuration as the actual P.C. Board.

**VCO UNIT**  
• BOTTOM VIEW

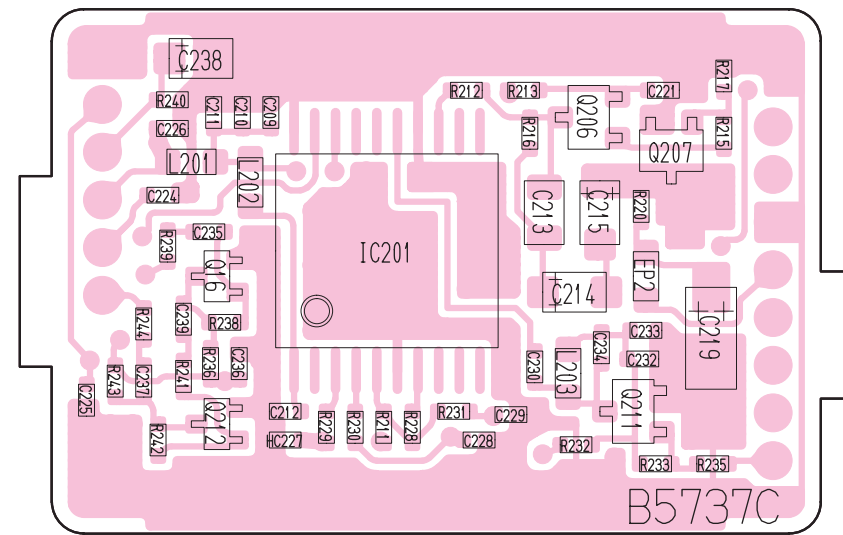

**AF unit**  
• BOTTOM VIEW

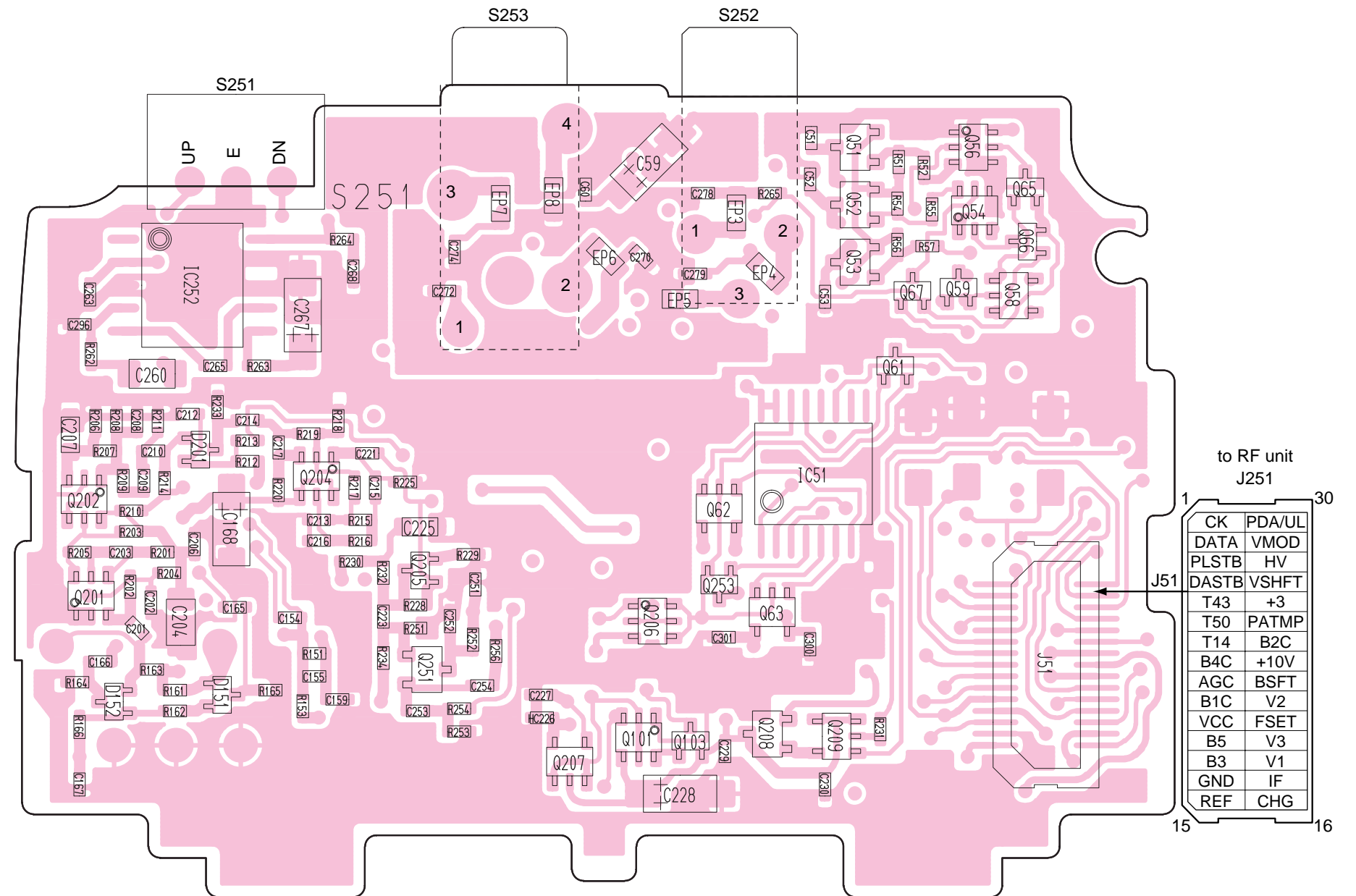



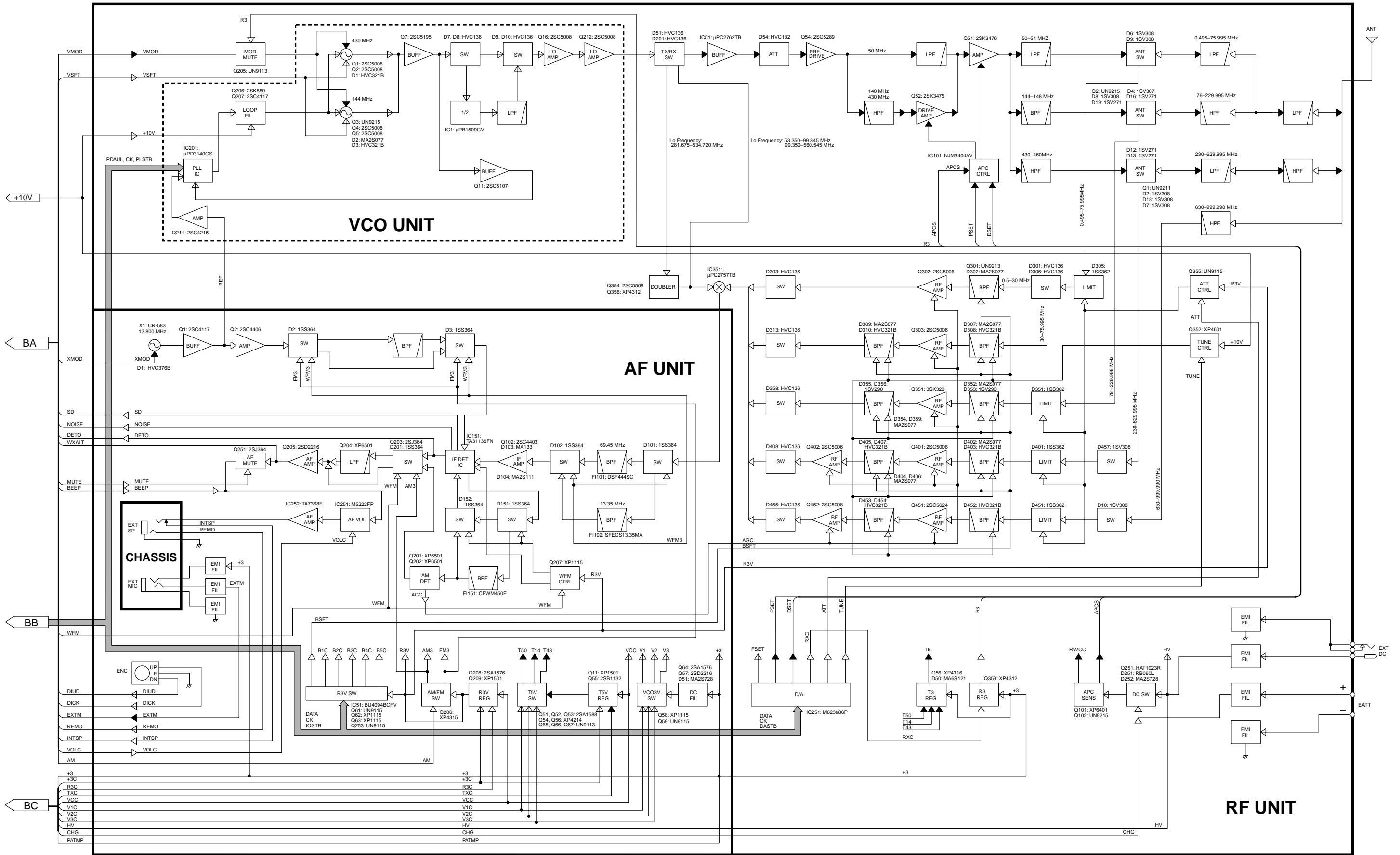

# SECTION 11 VOLTAGE DIAGRAM

## 11 - 1 LOGIC UNIT

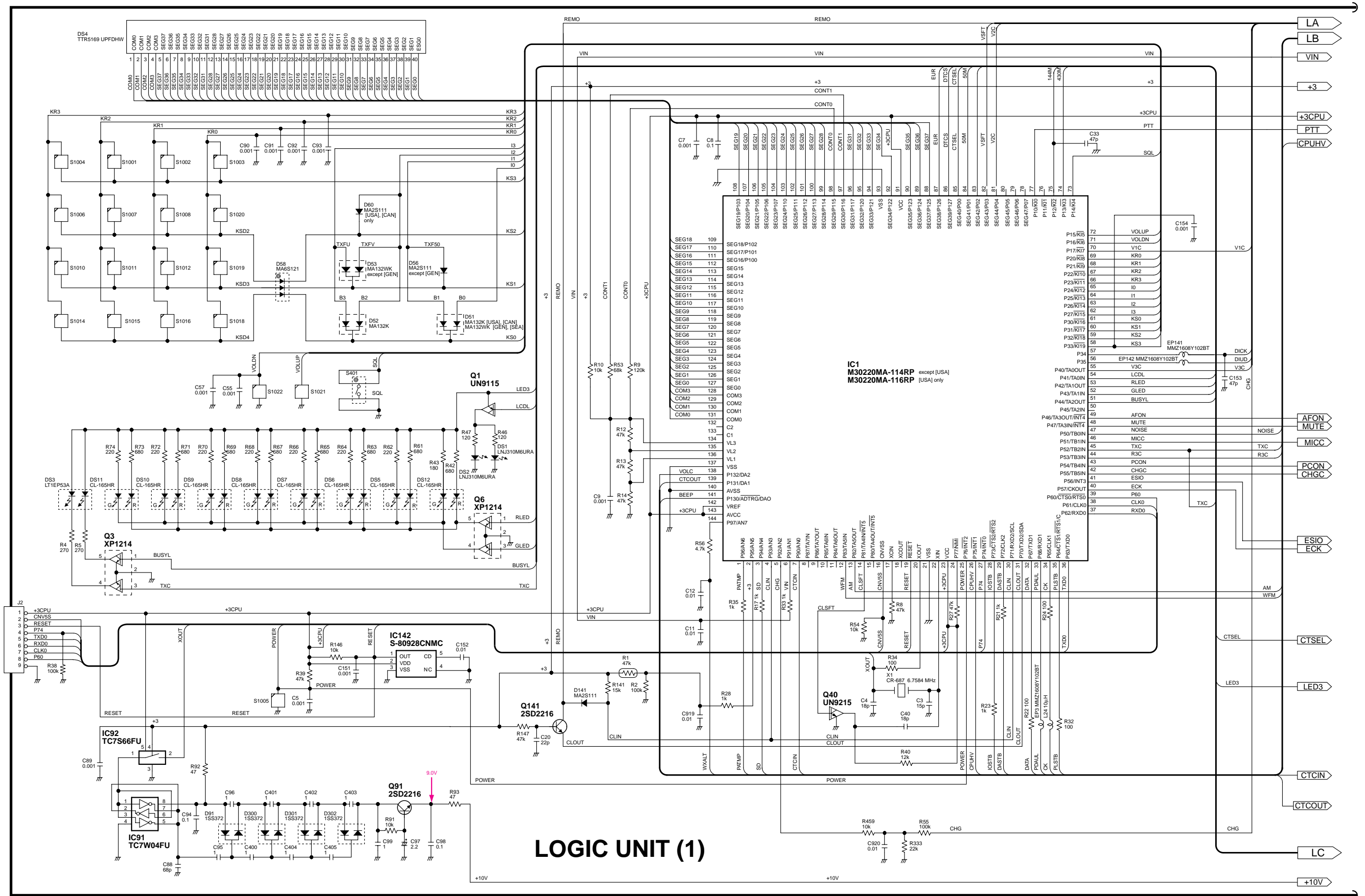

**LOGIC UNIT (1)**



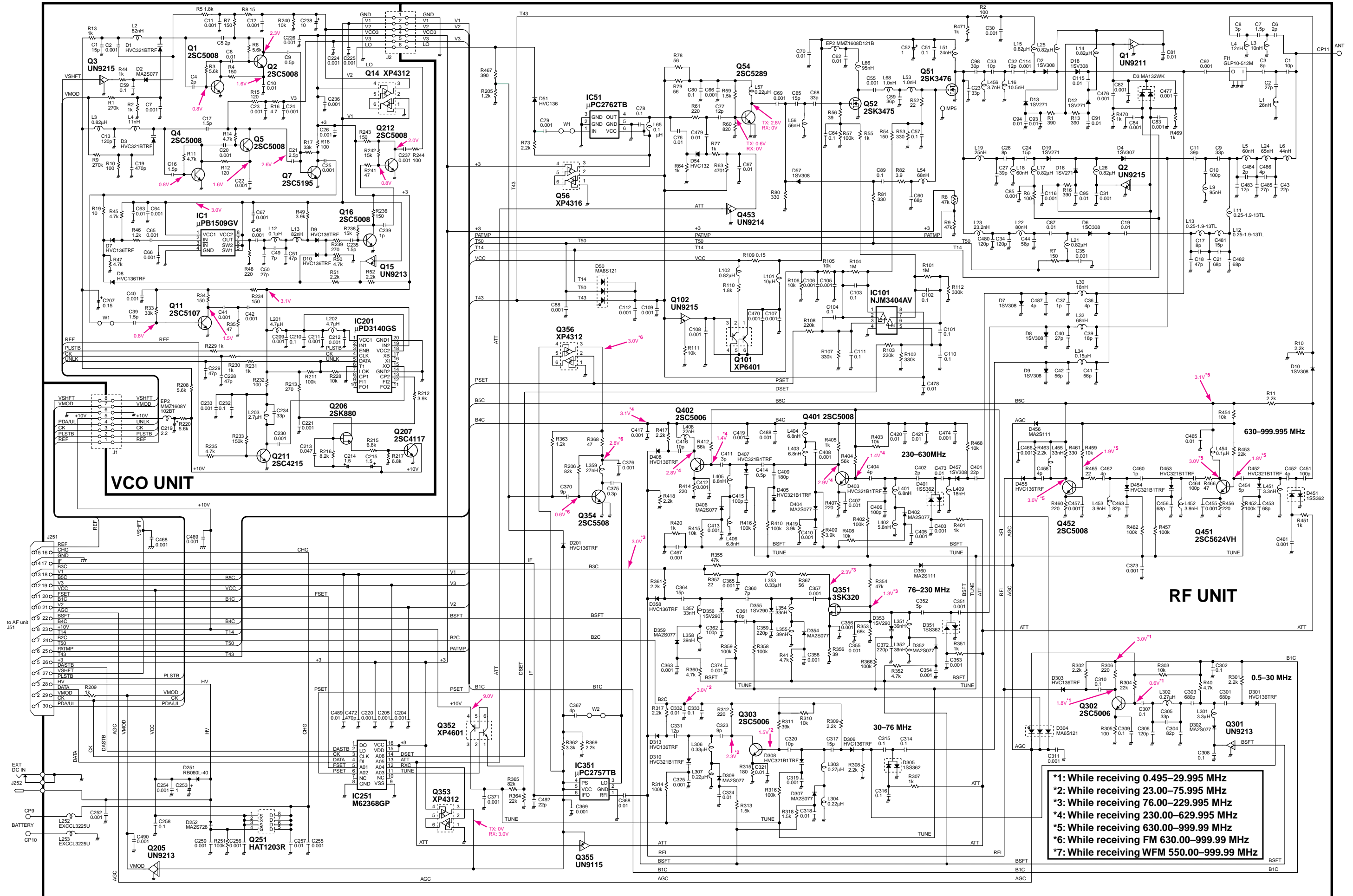

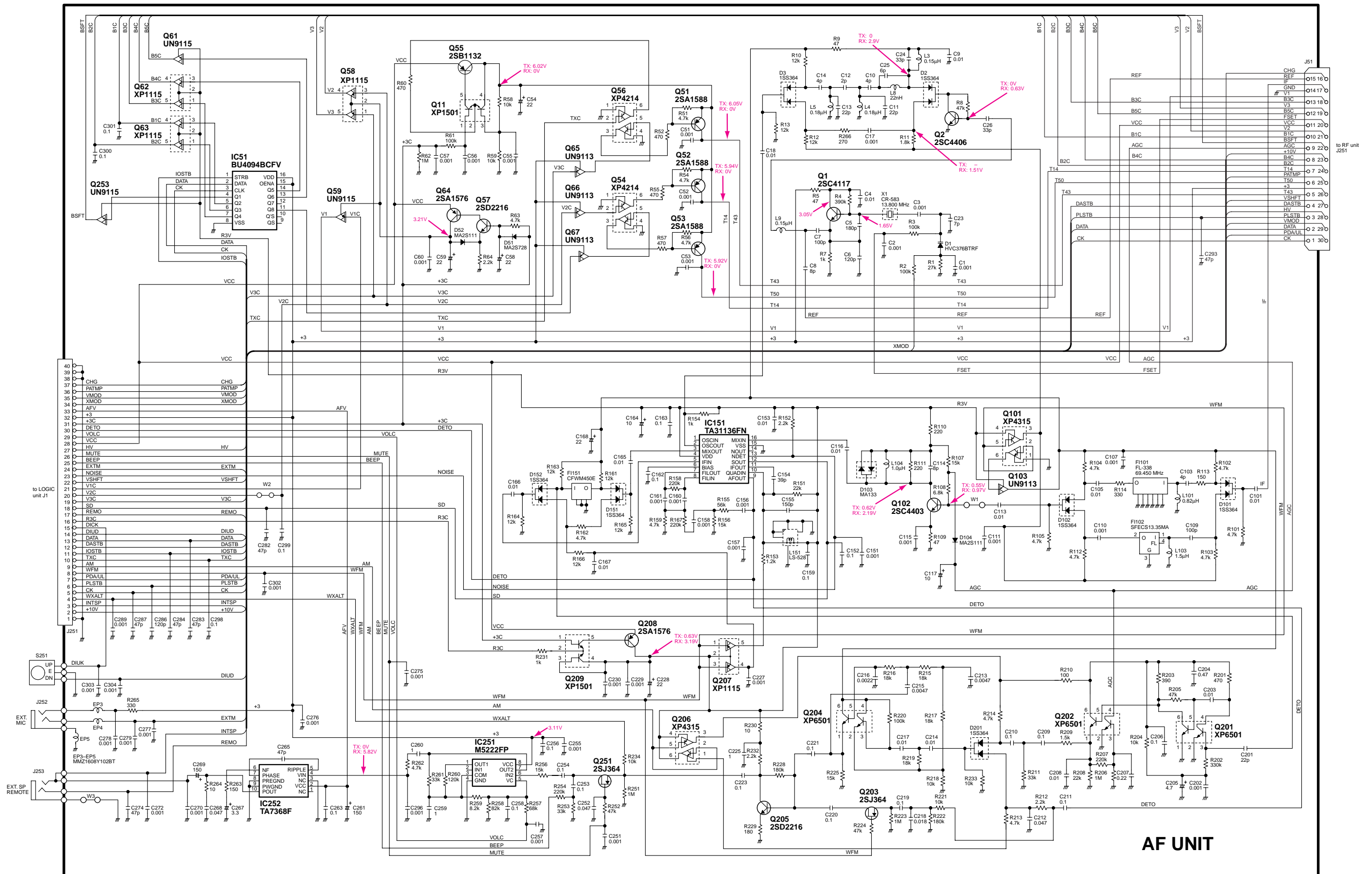

## Icom Inc.

1-1-32, Kamiminami, Hirano-ku, Osaka 547-0003, Japan  
Phone : 06 6793 5302  
Fax : 06 6793 0013  
URL : <http://www.icom.co.jp/world/index.html>

### Icom America Inc.

<Corporate Headquarters>  
2380 116th Avenue N.E., Bellevue, WA 98004, U.S.A.  
Phone : (425) 454-8155 Fax : (425) 454-1509  
URL : <http://www.icomamerica.com>  
<Customer Service>  
Phone : (425) 454-7619

### Icom Canada

Glenwood Centre #150-6165  
Highway 17 Delta, B.C., V4K 5B8, Canada  
Phone : (604) 952-4266 Fax : (604) 952-0090  
URL : <http://www.icomcanada.com>

### Icom (Australia) Pty. Ltd.

A.B.N. 88 006 092 575  
290-294 Albert Street, Brunswick, Victoria, 3056, Australia  
Phone : 03 9387 0666 Fax : 03 9387 0022  
URL : <http://www.icom.net.au>

### Icom New Zealand

146A Harris Road, East Tamaki,  
Auckland, New Zealand  
Phone : 09 274 4062 Fax : 09 274 4708  
URL : <http://www.icom.co.nz>

### Icom (Europe) GmbH

Communication Equipment  
Himmelgeister Str. 100, D-40225 D sseldorf, Germany  
Phone : 0211 346047 Fax : 0211 333639  
URL : <http://www.icomeurope.com>

### Icom Spain S.L

Ctra. de Gracia a Manresa Km. 14,750  
08190 Sant Cugat del Valles Barcelona, SPAIN  
Phone : (93) 590 26 70 Fax : (93) 589 04 46  
URL : <http://www.icomspain.com>

### Icom (UK) Ltd.

Unit 9, Sea St., Herne Bay, Kent, CT6 8LD, U.K.  
Phone : 01227 741741 Fax : 01227 741742  
URL : <http://www.icomuk.co.uk>

### Icom France S.a

Zac de la Plaine, Rue Brindejonc des Moulinais  
BP 5804, 31505 Toulouse Cedex, France  
Phone : 561 36 03 03 Fax : 561 36 03 00  
URL : <http://www.icom-france.com>

### Asia Icom Inc.

6F No. 68, Sec. 1 Cheng-Teh Road, Taipei, Taiwan, R.O.C.  
Phone : (02) 2559 1899 Fax : (02) 2559 1874



**Count on us!**

## Free Manuals Download Website

<http://myh66.com>

<http://usermanuals.us>

<http://www.somanuals.com>

<http://www.4manuals.cc>

<http://www.manual-lib.com>

<http://www.404manual.com>

<http://www.luxmanual.com>

<http://aubethermostatmanual.com>

Golf course search by state

<http://golfingnear.com>

Email search by domain

<http://emailbydomain.com>

Auto manuals search

<http://auto.somanuals.com>

TV manuals search

<http://tv.somanuals.com>