

NOTE:
Please read all instructions
carefully before using this
product

Table of Contents

Safety Notice

Hardware Identifier

Assembly Instruction

Exploded Diagram

Parts List

Warranty

Ordering Parts

**Model
CB-349**

**Retain This
Manual for
Reference**

July 15, 2004

**OWNER'S
MANUAL**

IMPEX
F I T N E S S P R O D U C T S

COMPETITOR CB-349 BENCH

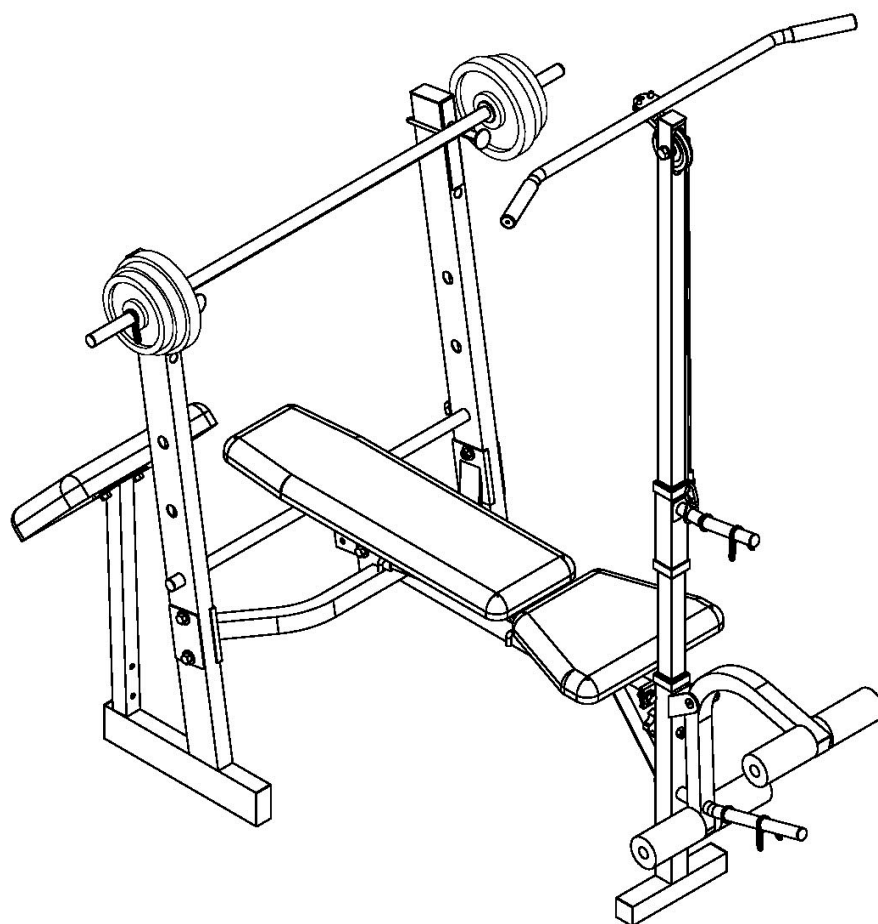

IMPEX INC.

14777 Don Julian Rd., City of Industry, CA 91746

Tel: (800) 999-8899 Fax (626) 961-9966

www.impex-fitness.com

info@impex-fitness.com

TABLE OF CONTENTS

BEFORE YOU BEGIN.....	1
IMPORTANT SAFETY NOTICE.....	2
HARDWARE IDENTIFIER.....	3
ASSEMBLY INSTRUCTIONS.....	4
EXPLODED DIAGRAM.....	10
PARTS LIST.....	11
WARRANTY.....	12
ORDERING PARTS.....	12

BEFORE YOU BEGIN

Thank you for selecting the Competitor CB-349 BENCH by IMPEX FITNESS PRODUCTS. For your safety and benefit, read this manual carefully before using the machine. As a manufacturer, we are committed to provide you complete customer satisfaction. If you have any questions, or find there are missing or damaged parts, we guarantee you complete satisfaction through direct assistance from our factory. To avoid unnecessary delays, *please call our TOLL-FREE customer service number.* Our Customer Service Agents will provide immediate assistance to you.

<p>Toll-Free Customer Service Number 1-800-999-8899 Mon. - Fri. 9 a.m. - 5 p.m. PST www.impex-fitness.com info@impex-fitness.com</p>

IMPORTANT SAFETY NOTICE

PRECAUTIONS

This exercise machine is built for optimum safety. However, certain precautions apply whenever you operate a piece of exercise equipment. Be sure to read the entire manual before you assemble or operate your machine. In particular, note the following safety precautions:

- 1. Keep children and pets away from the machine at all times. DO NOT leave children unattended in the same room with the machine.**
2. Only one person at a time should use the machine.
3. If the user experiences dizziness, nausea, chest pain, or any other abnormal symptoms, STOP the workout at once. CONSULT A PHYSICIAN IMMEDIATELY.
4. Position the machine on a clear, leveled surface. DO NOT use the machine near water or outdoors.
5. Keep hands away from all moving parts.
6. Always wear appropriate workout clothing when exercising. DO NOT wear robes or other clothing that could become caught in the machine. Running or aerobic shoes are also required when using the machine.
7. Use the machine only for its intended use as described in this manual. DO NOT use attachments not recommended by the manufacturer.
8. Do not place any sharp object around the machine.
9. Disabled person should not use the machine without a qualified person or physician in attendance.
10. Before using the machine to exercise, always do stretching exercises to properly warm up.
11. Never operate the machine if the machine is not functioning properly.
12. A spotter is recommended during exercise.

WARNING: BEFORE BEGINNING ANY EXERCISE PROGRAM, CONSULT YOUR PHYSICIAN. THIS IS ESPECIALLY IMPORTANT FOR INDIVIDUALS OVER THE AGE OF 35 OR PERSONS WITH PRE-EXISTING HEALTH PROBLEMS. READ ALL INSTRUCTIONS BEFORE USING ANY FITNESS EQUIPMENT. IMPEX INC. ASSUMES NO RESPONSIBILITY FOR PERSONAL INJURY OR PROPERTY DAMAGE SUSTAINED BY OR THROUGH THE USE OF THIS PRODUCT.

SAVE THESE INSTRUCTIONS.

HARDWARE IDENTIFIER

PLACE WASHER, END OF BOLT, OR SCREW ON CIRCLE TO CHECK FOR CORRECT SIZE.

MILLIMETERS

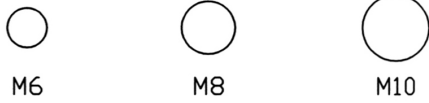

INCHES

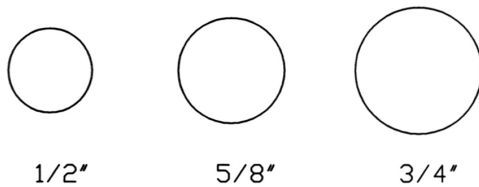

REPLACEMENT PARTS

Thank you for purchasing IMPEX product. Although we go to great effort to ensure the quality of our products, Occasionally errors or omissions occur. Should you find either a defective or missing part in this product, Please contact us for a replacement at the telephone number.

QUESTION ?



1-800-999-8899

NOTE: When installing a Aircraft Nut (also called Nylon or Lock Nut), Please use two adjustable wrenches to tighten down the Nut. Hold down the Bolt with one wrench, and use the other wrench to turn the Nut clockwise.

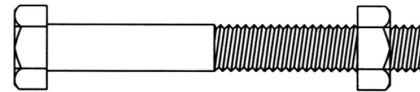
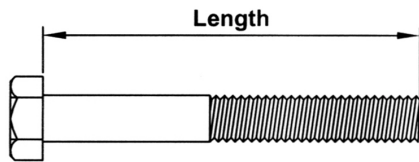

HEX HEAD BOLT

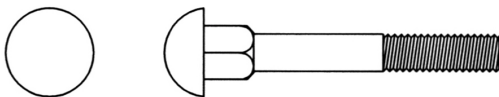

CARRIAGE BOLT

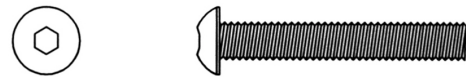

ALLEN BOLT



AIRCRAFT NUT



FLAT WASHER

ASSEMBLY INSTRUCTION

Tools required assembling the machine: Two Adjustable Wrenches and Allen Wrenches

STEP 1 (SEE Diagram 1)

- A.) Connect the two Rear Upright Beams (#1) by a Cross Brace (#15) in the Mid-span. Secure them with two M10 x 2 3/8" Hex Bolts (#2), four \varnothing 3/4" Washers (#3), one Bracket (#7), and two M10 Aircraft Nuts (#4) on each end of the Cross Brace.
- B.) Insert the Backrest Adjustment Bar (#10) through a selected hole to obtain desired incline of Backrest.
- C.) Insert two Bar Catches (#13) & (#14) into the selected hole on the Rear Upright Beams (#1) to obtain the desired height to hold the weight bar.

DIAGRAM 1

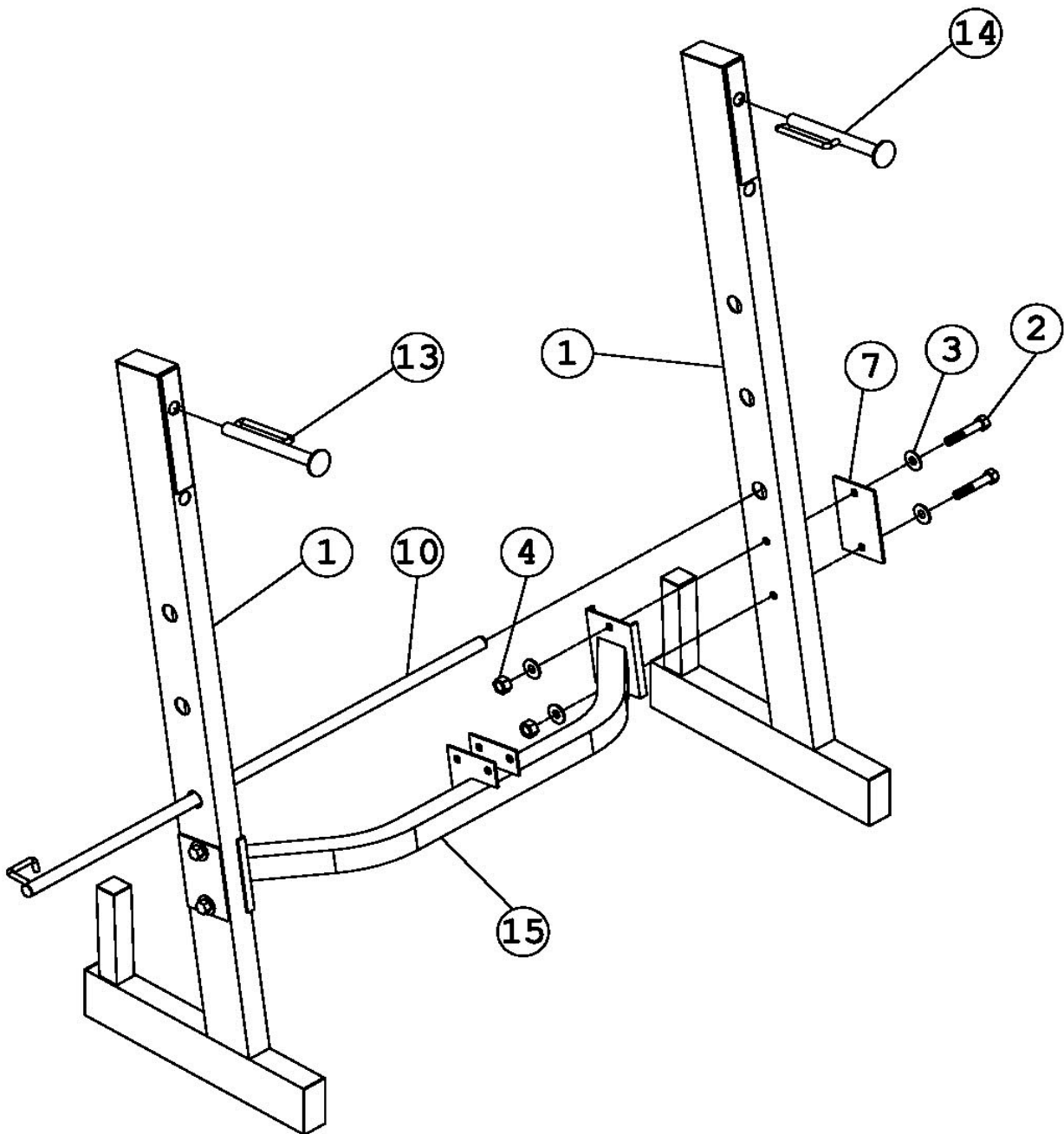

STEP 2 (SEE DIAGRAM 2)

- A.) Connect the Front Stabilizer (#42) to the Main Seat Support (#52) and secure them with two M10 x $\frac{3}{4}$ " Hex Bolts (#46), four $\varnothing \frac{3}{4}$ " Washers (#3), and two M10 Aircraft Nuts (#4). DO NOT tighten the nuts and bolts yet.
- B.) Connect the Main Seat Support (#52) to the open bracket on the Cross Brace (#15). Secure the rear hole on the bracket with one M10 x 2 $\frac{3}{8}$ " Bolt (#2), two $\varnothing \frac{3}{4}$ " Washers (#3), and one M10 Aircraft Nut (#4). Secure the other hole with a 3" Lock Pin (#8). Note: DO NOT over tighten the nut and bolt. The Main Frame needs to pivot on this bolt in able to fold up the bench.
- C.) Connect one end of Diagonal Support (#43) to the Main Seat Support (#52). Secure it with one M8 x 2 $\frac{1}{8}$ " Hex Bolt (#48), two $\varnothing \frac{5}{8}$ " Washers (#21) and one M8 Aircraft Nut (#49). Connect the other end to the Front Stabilizer. Secure it with one M8 x $\frac{5}{8}$ " Hex Bolt (#20) and $\varnothing \frac{5}{8}$ " Washer (#21).
- D.) Securely tighten all the nuts and bolts previously installed.
- E.) Insert 6 $\frac{1}{2}$ " Long Lock Pin (#53) into the hole on the Main Seat Support (52). NOTE: The Pin is not designed to sustain any heavy weight. Only use the pin when changing the backrest board to a vertical position while doing Walk-in-Squat from the rear.

DIAGRAM 2

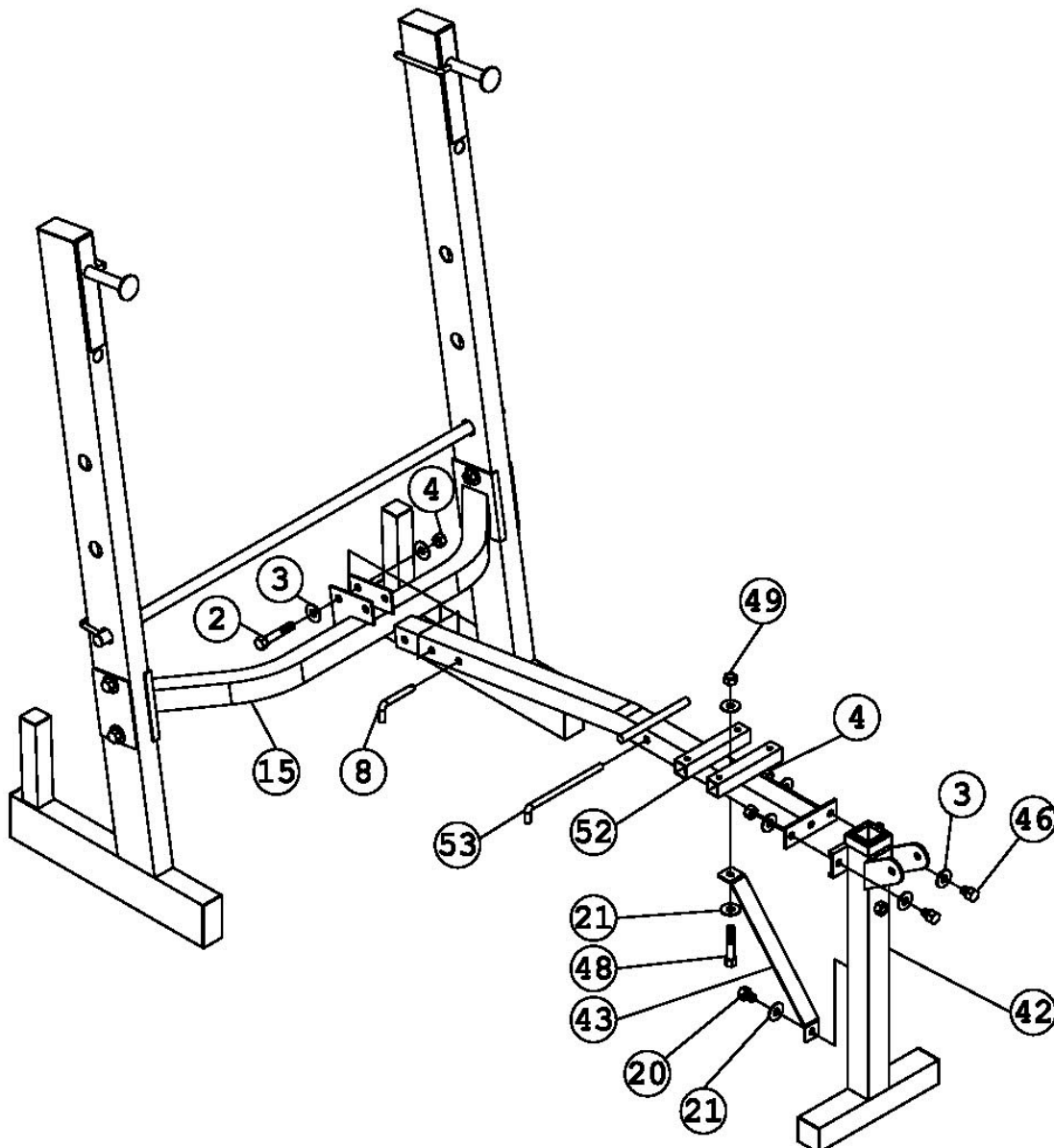

STEP 3 (SEE DIAGRAM 3)

- A.) Attach the Leg Developer (#38) onto the bracket on the Front Stabilizer (#42). Secure it with a Hex Socket Axle (#44) and Hex Socket Screw (#45).
- B.) Insert two Foam Roll Tubes (#39) halfway through the hole on the Leg Developer (#38). Push four Foam Rolls (#37) onto the tubes from both sides.
- C.) Place a Spring Clip (#34) onto the post on the Leg Developer .

DIAGRAM 3

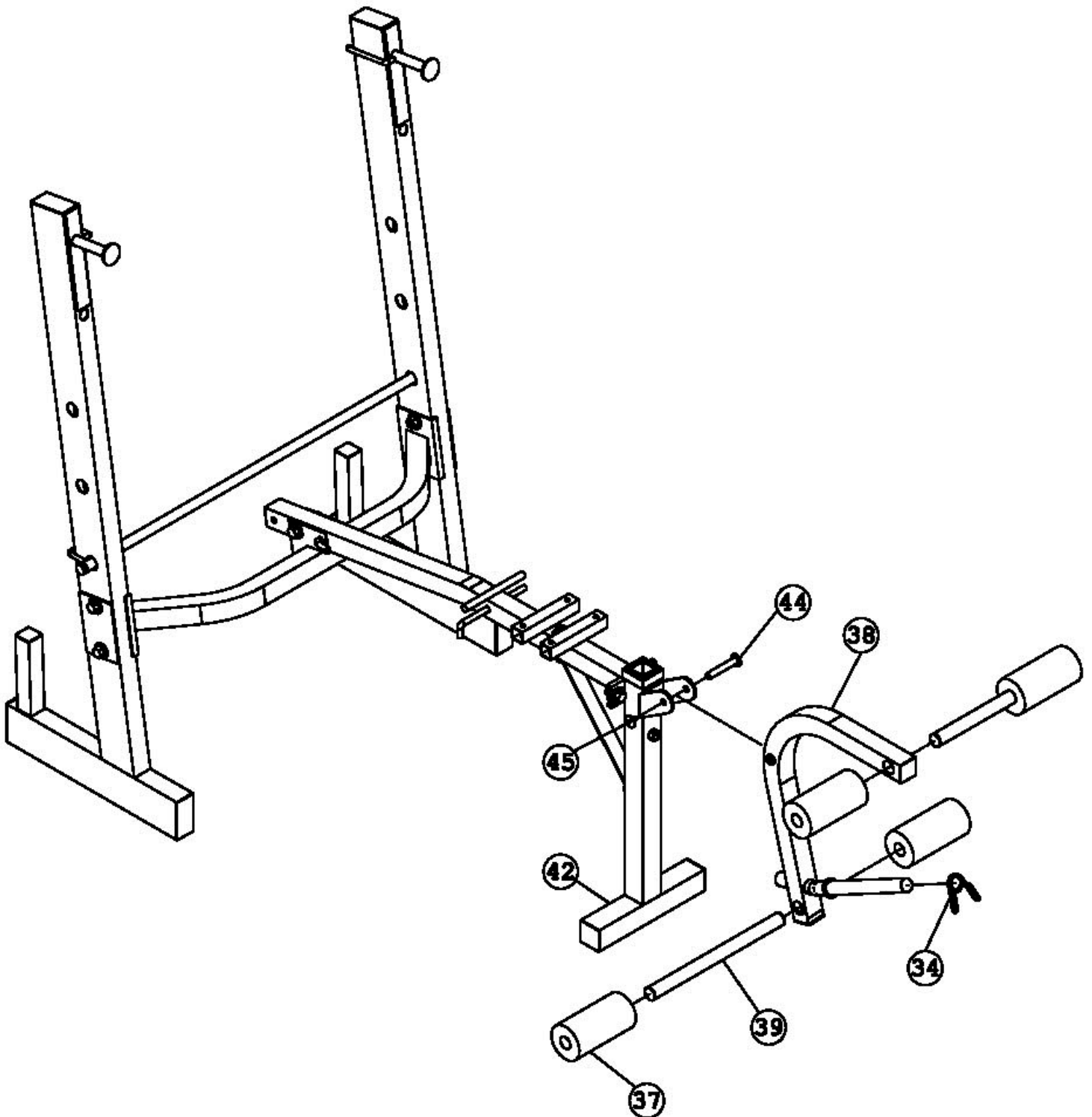

STEP 4 (SEE DIAGRAM 4)

- A.) Attach the hole-side of the Backrest Supports (#16) onto both ends of the Pivot on the Main Seat Support (#52) and place the other side rest against the Backrest Adjustment Bar (#10).
- B.) Place the Backrest Board (#18) onto the Backrest Supports (#16). Secure it with four M6 x 1 3/8" Hex Bolts (#50) and \varnothing 1/2" Washers (#51).
- C.) Place Seat (#19) onto the bracket on the Main Seat Support (#52). Align the holes and secure the Seat with four M6 x 1 3/8" Hex Bolts (#50) and \varnothing 1/2" Washers (#51).
- D.) Insert the Arm Curl Stand (#22) into the opening on the top of the Front Stabilizer (#42). Secure it with a Knob Bolt (#47).
- E.) Attach the Arm Curl Pad (#23) to the Arm Curl Stand (#22). Secure it with two M8 x 5/8" Hex Bolts (#20) and \varnothing 5/8" Washers (#21).

DIAGRAM 4

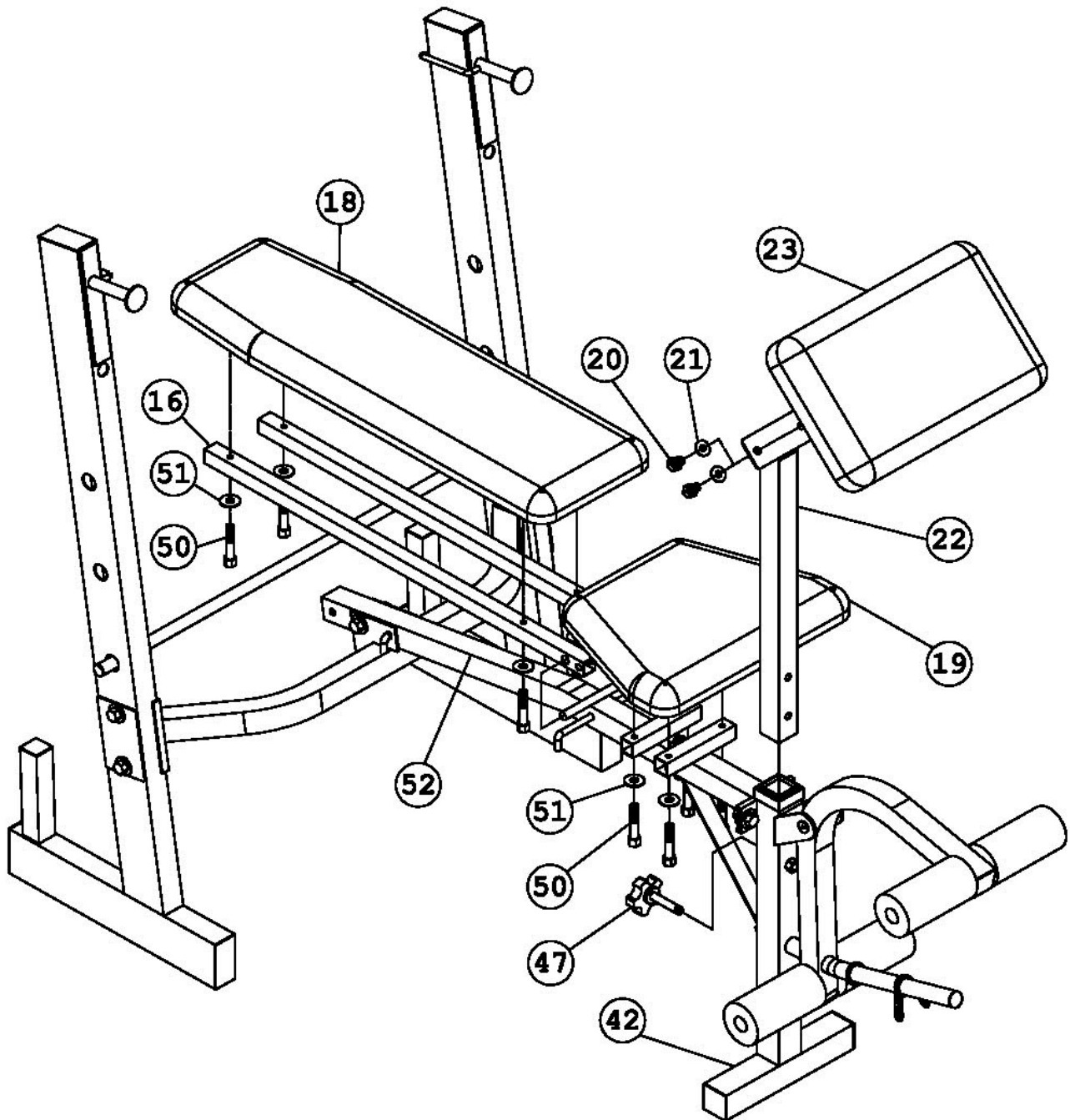

STEP 5 (SEE Diagram 5)

- A.) Attach the ball end of the Cable to the Pulley (#28). Place the Pulley in the open slot on the Lat Bar Frame (#31). Secure it with one M10 x 2 1/8" Hex Bolt (#32), two Bushings (#29), two $\text{\O} \frac{3}{4}$ " Washers (#3), and one M10 Aircraft Nut (#4).
- B.) Slide the Weight Holder (#33) onto the Lat Bar Frame from the bottom. Connect the Cable to the Holder with a Hook (#26).
- C.) Connect the Lat Bar (#25) to the Cable with a Hook (#26). When using the Lat Pull down, remove the Arm Curl and place it on the storage post behind the Rear Upright Beam. Then insert the Lat Bar Frame into the opening on the Front Stabilizer.

DIAGRAM 5

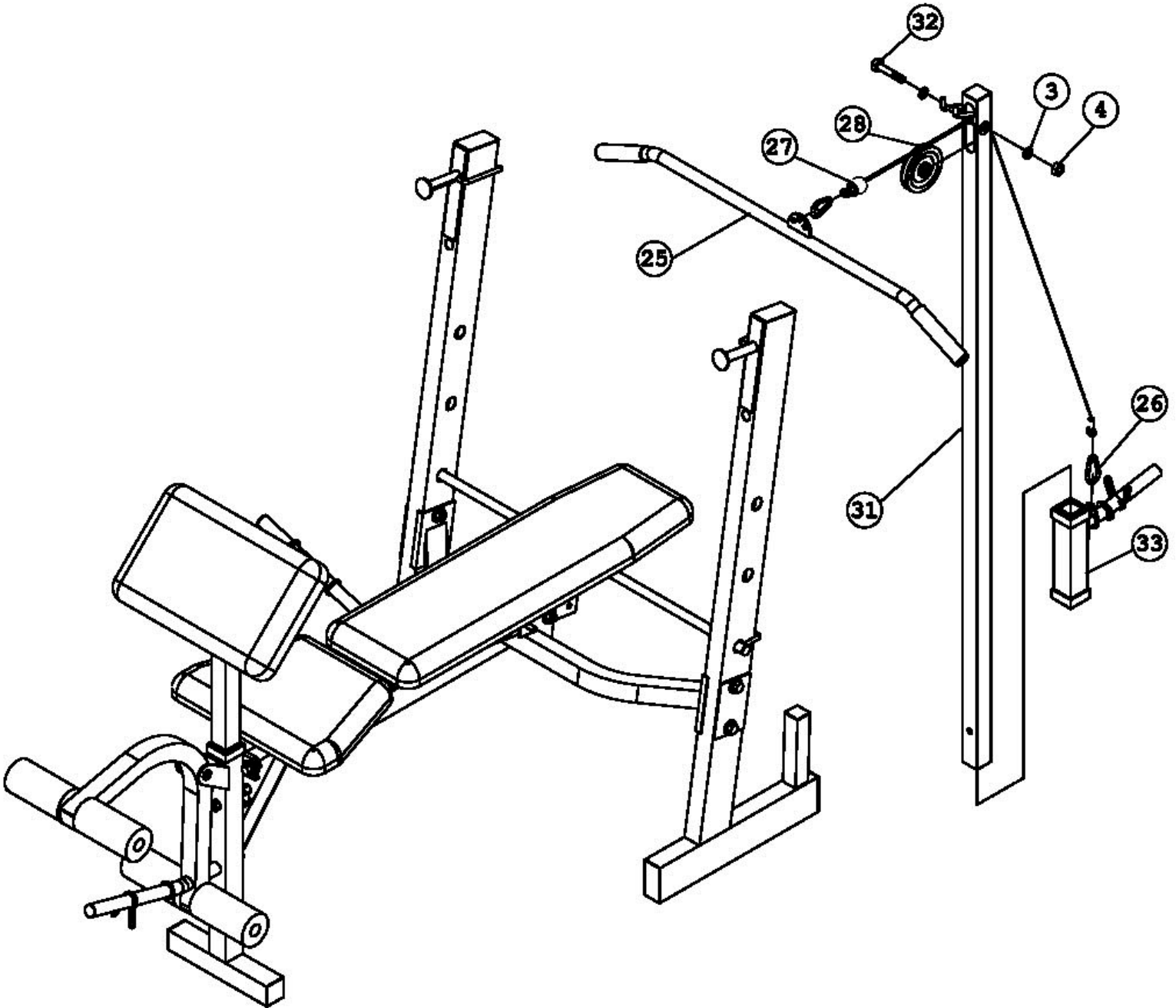

STEP 6 (SEE Diagram 6)

- A.) To store the bench in a vertical position, remove the Arm Curl and the Lat Bar Frame from the bench and place them onto the storage posts on the Rear Upright Beams.
- B.) Pull out the 3" Lock Pin (#8) on the Main Seat Support to fold up the bench. Make sure to re-insert the Lock Pin on the bracket to secure the vertical position.

DIAGRAM 6

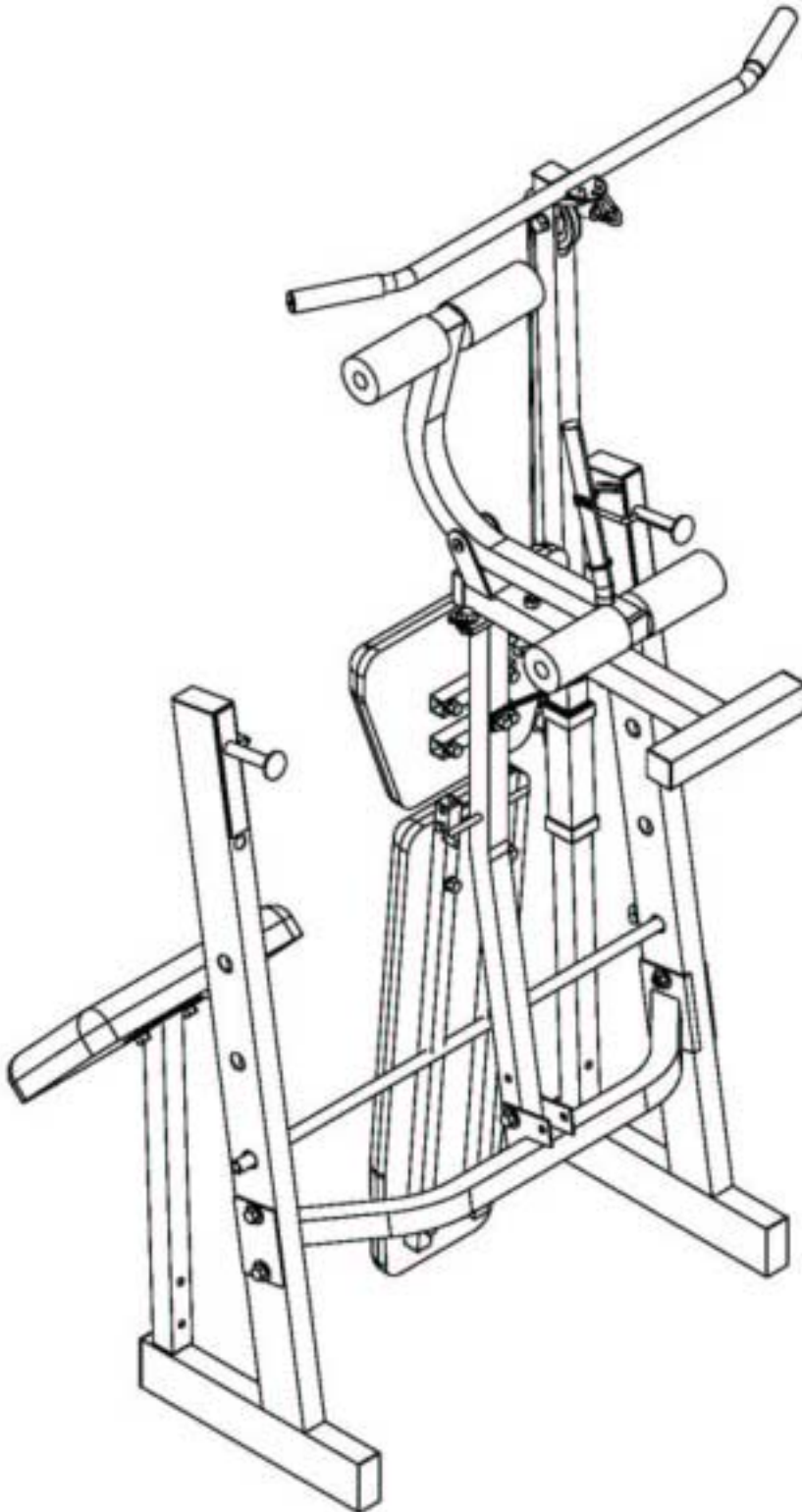

EXPLODED DIAGRAM

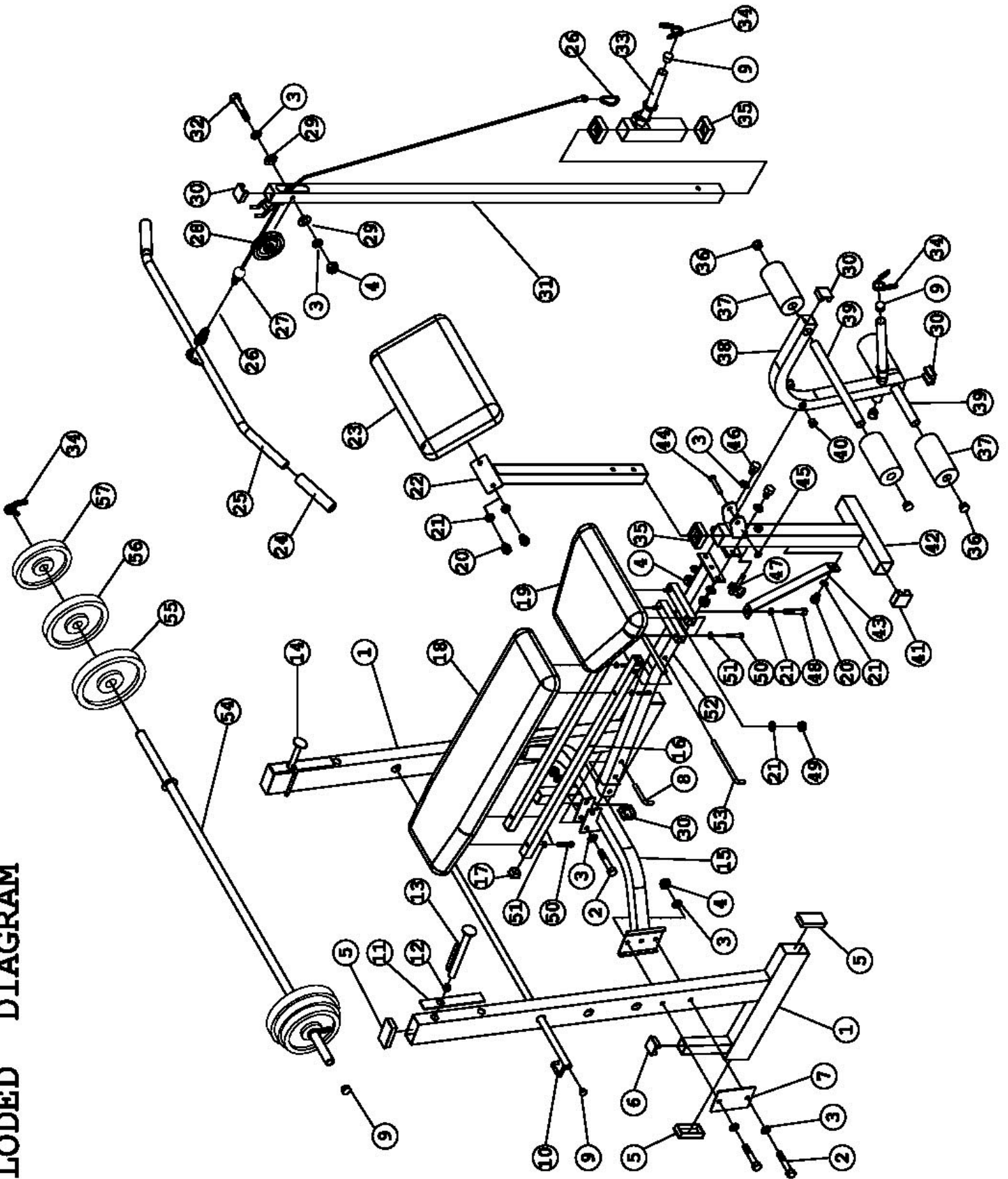

PARTS LIST

KEY NO.	DESCRIPTION	QUANTITY
1	Rear Upright Beam	2
2	M10 x 2 3/8" Hex Bolt	5
3	Ø 3/4" Washer	16
4	M10 Aircraft Nut	8
5	1 5/8" x 3 1/8" Square End Cap	6
6	1 1/4" Square End Cap	2
7	Bracket	2
8	3" Short Lock Pin	1
9	Ø 1" Round End Cap	7
10	Backrest Adjustment Bar	1
11	Bar Catch Panel	2
12	Ø 3/4" Bar Catch End Cap	2
13	Right Bar Catch	1
14	Left Bar Catch	1
15	Cross Brace	1
16	Backrest Support	2
17	1" Square End Cap	2
18	Backrest Board	1
19	Seat	1
20	M8 x 5/8" Hex Bolt	3
21	Ø 5/8" Washer	5
22	Arm Curl Stand	1
23	Arm Curl Pad	1
24	Handle Grip	2
25	Lat Bar	1
26	Hook	2
27	Cable	1
28	Pulley	1
29	Pulley Bushing	2
30	1 1/2" Square End Cap	4
31	Lat Bar Frame	1
32	M10 x 2 1/8" Hex Bolt	1
33	Weight Holder	1
34	Spring Clip	4
35	Sleeve	3
36	Ø 1" Foam Roll End Cap	4
37	Foam Roll	4
38	Leg Developer	1
39	Foam Roll Tube	2
40	Plastic Bushing	2
41	1 3/4" Square End Cap	2
42	Front Stabilizer	1
43	Diagonal Support	1
44	Hex Socket Axle	1
45	Hex Socket Screw	1
46	M10 x 3/4" Hex Bolt	2
47	Knob Bolt	1
48	M8 x 2 1/8" Hex Bolt	1
49	M8 Aircraft Nut	1
50	M6 x 1 3/8" Hex Bolt	8
51	Ø 1/2" Washer	8
52	Main Seat Support	1
53	6 1/2" Long Lock Pin	1
54	Weight Bar	1
55	Weight Plate 25#	2
56	Weight Plate 15#	2
57	Weight Plate 10#	2

IMPEX INC.

LIMITED WARRANTY

IMPEX Inc. ("IMPEX") warrants this product to be free from defects in workmanship and material, under normal use and service conditions, for a period of two years on the Frame from the date of purchase. This warranty extends only to the original purchaser. IMPEX's obligation under this Warranty is limited to replacing or repairing, at IMPEX's option.

All returns must be pre-authorized by IMPEX. Pre-authorization may be obtained by calling IMPEX Customer Service Department at 1-800-999-8899. All freights on products returned to IMPEX must be prepaid by the customer. This warranty does not extend to any product or damage to a product caused by or attributable to freight damage, abuse, misuse, improper or abnormal usage or repairs not provided by a IMPEX authorized service center or for products used for commercial or rental purposes. No other warranty beyond that specifically set forth above is authorized by IMPEX.

IMPEX is not responsible or liable for indirect, special or consequential damages arising out of or in connection with the use or performance of the product or other damages with respect to any economic loss, loss of property, loss of revenues or profits, loss of enjoyments or use, costs of removal, installation or other consequential damages or whatsoever natures. Some states do not allow the exclusion or limitation of incidental or consequential damages. Accordingly, the above limitation may not apply to you.

The warranty extended hereunder is in lieu of any and all other warranties and any implied warranties of merchantability or fitness for a particular purpose is limited in its scope and duration to the terms set forth herein. Some states do not allow limitations on how long an implied warranty lasts. Accordingly, the above limitation may not apply to you.

This warranty gives you specific legal right. You may also have other rights which vary from state to state. **Register on-line www.impex-fitness.com**

IMPEX INC.
14777 Don Julian
City of Industry, CA 91746

ORDERING REPLACEMENT PARTS

Replacement parts can be ordered by calling our Customer Service Department toll-free at 1-800-999-8899 during our regular business hours: Monday through Friday, 9 am until 5 pm Pacific standard time.
info@impex-fitness.com

When ordering replacement parts, always give the following information.

1. Model
2. Description of Parts
3. Part Number
4. Date of Purchase

Free Manuals Download Website

<http://myh66.com>

<http://usermanuals.us>

<http://www.somanuals.com>

<http://www.4manuals.cc>

<http://www.manual-lib.com>

<http://www.404manual.com>

<http://www.luxmanual.com>

<http://aubethermostatmanual.com>

Golf course search by state

<http://golfingnear.com>

Email search by domain

<http://emailbydomain.com>

Auto manuals search

<http://auto.somanuals.com>

TV manuals search

<http://tv.somanuals.com>