

# WATER HEATER

## INSTALLATION MANUAL

# ELECTRIC WATER HEATER INSTALLATION AND OPERATING INSTRUCTIONS

Read these instructions thoroughly before starting

### TABLE OF CONTENTS

I) Water Pipe Connections .....	1
II) Power Supply \ Wiring .....	1
III) Filling & Draining Tank .....	2
IV) Installation Checklist .....	2
V) Temperature Adjustment .....	2
VI) Service And Maintenance .....	2 to 3
VII) Trouble-Shooting .....	3
VIII) Pressure Buildup (Thermal Expansion) .....	4
IX) Warranty .....	5

**PLEASE RETAIN THESE INSTRUCTIONS IN A SAFE LOCATION FOR FUTURE REFERENCE**

#### **▲ FOR YOUR SAFETY**

- Do not store or use gasoline or other flammable vapours and liquids in the vicinity of this or any other appliance.
- Installation and service must be performed by a qualified installer, service agency or the electric utility.

**▲WARNING: Improper installation, adjustment, alteration, service, or maintenance can cause injury or property damage. Refer to this manual. For assistance or additional information, consult a qualified installer, service agency, or the electric utility.**

**▲WARNING: If the information in these instructions is not followed exactly, a fire or explosion may result causing property damage, personal injury or death.**

IF YOU HAVE ANY INSTALLATION, PERFORMANCE OR OPERATIONAL QUESTIONS PLEASE CALL THE FOLLOWING NUMBER, PRIOR TO REMOVING THE WATER HEATER

(if this is a rental water heater please contact the rental company)

**1-888-GSW-TECH  
1-888-479-8324**

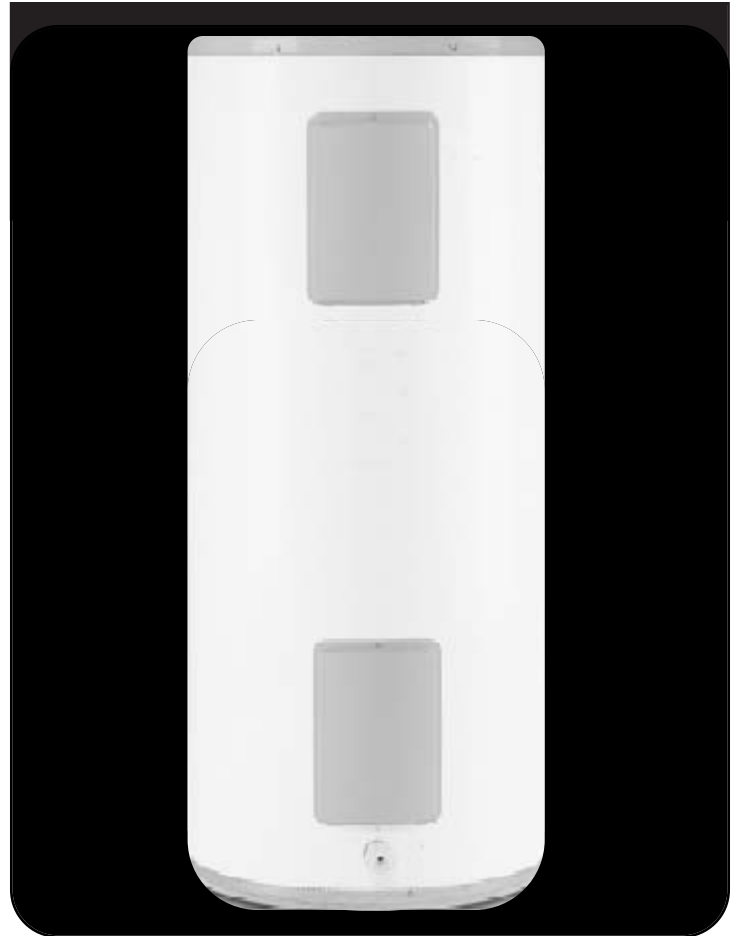

### INSTALLATION RECORD

This water heater is protected by a multi-year warranty against leaks plus a one (1) year warranty on parts.

Record key data here for future reference and prompt service:

Installed By / Purchased From:		
Installation Date:	Location of Electrical Switch or Circuit Protector:	
Model Number	Serial Number	
Watts	Watts	Watts-Total
Volts	P.S.I.	U.S. Gal.

PART NO. 61515 REV. C (03-01)

## PLUMBING

- The cold water inlet is identified at the top of the heater (unless bottom entry). The hot water connection is also identified at the top of the heater. Install a shut-off valve in the cold line approximately 3' from the inlet to the heater where it is in convenient reach. This valve is for emergency shut-off and **MUST** be kept open during the operation of the heater.
- All nipples contain a plastic lining to minimize corrosion (cold inlet nipples have double sleeve, hot outlet nipples have a single sleeve). Do not apply heat to these nipples when making solder connections. Sweat a piece of tubing to adapter before fitting adapter to nipple.
- A combination Temperature and Pressure relief valve **MUST** be installed. In some cases it is necessary that a Tee be fitted in the top of the heater which allows the temperature probe to reach into the top of the tank. See diagram on page 4. No shut-off valve of any kind is permitted between the tank and the relief valve. The outlet of the relief valve must be piped to a drain or fixture, and must terminate within 6" of the floor.

## ELECTRICAL

- Check to see that the element marking and nameplate data do correspond with the electric service available.
  - The junction box where electrical connections are made is located near the top of the heater, near the upper access door.
- Install a circuit directly from the main fuse box. This circuit must be the right size for the length of run and the load (see chart below).

### RECOMMENDED FOR AMPERAGE

MAX. WATTS	MAX. VOLTS		
	120V	208V	240V
1500	20A	10A	10A
3000	35A	20A	20A
3500	40A	20A	20A
4500		30A	25A
5500		35A	35A

### The heater must be well grounded.

- A ground wire must run from the green ground screw provided at the electrical connection point in the heater junction box to the ground connection at the service panel.
- Adequate fusing must be provided at the service entrance as required by local codes and/or electric utility having jurisdiction. This can be accomplished with either a circuit breaker or fuse block in the service panel or a separate disconnect switch, so that electric power can be shut off easily when working on the heater.
- Final connections are made at the junction box in the heater. Access to the junction box is obtained by removing the cover near the knockouts.
- The heater you have received is internally wired. A specific wiring diagram is located inside the upper door or for certain models on the rating plate. All wiring is color-coded and connections must be made as shown in the wiring diagram.

**MAKE SURE HEATER IS COMPLETELY FILLED WITH WATER BEFORE POWER IS TURNED ON. SEE 'FILLING TANK' SECTION.**

## WIRING

### TWO WIRE CIRCUIT FOR NON-SIMULTANEOUS OPERATION. SINGLE HIGH LIMIT.

The basic operation of a two thermostat system (upper and lower) on a electric water heater of 240 volts is as follows:

Only one element will come on at any one time. This is known as a flip/flop system. On a 240-volt water heater, there will always be 120 volts to both elements. The thermostat will direct the second leg of the 120-volt to the element to complete the 240 volts required for energizing the element.

**Initial Start Up:** When the tank is full of cold water, the upper thermostat will take priority and the top portion of the water will heat up to the setting of the thermostat. Once that temperature has been reached, the thermostat will then flip down the 120 volts to the lower thermostat. The thermostat switch closes and the bottom portion of the tank heats up until the water reaches the setting on that thermostat. At this point the tank will be full of hot water.

**Normal Operation:** When hot water is being used, cold water enters the bottom of the heater (either bottom feed or by diptube), and the bottom element will begin to heat the cold water. If lots of hot water has been used, the upper thermostat will take priority and the top portion of the heater will be heated. Once heated, the thermostat will flip down to the lower thermostat to heat the lower portion.

### TWO WIRE CIRCUIT FOR SINGLE (1) ELEMENT HEATERS EQUIPPED WITH SINGLE HIGH LIMIT CONTROL. SPACESAVER™ MODELS ONLY.

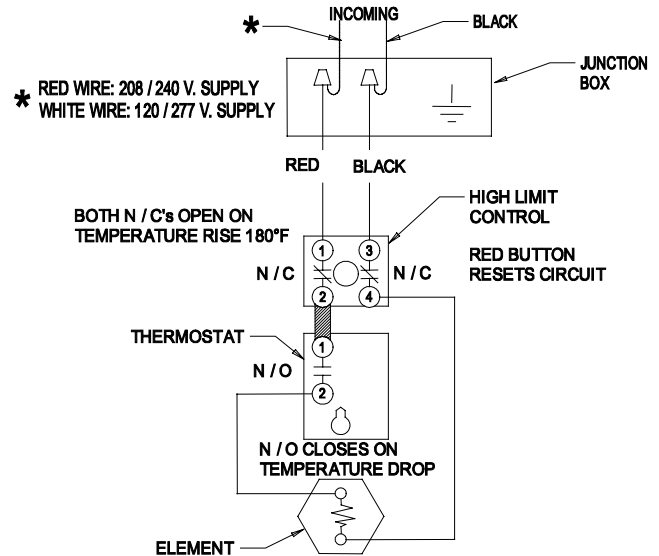

WATER HEATER MUST BE GROUNDED TO THE ELECTRIC SUPPLY SERVICE.

### TWO WIRE CIRCUIT FOR TWO (2) ELEMENT HEATERS EQUIPPED WITH SINGLE (1) HIGH LIMIT CONTROL. NON-SIMULTANEOUS OPERATION.

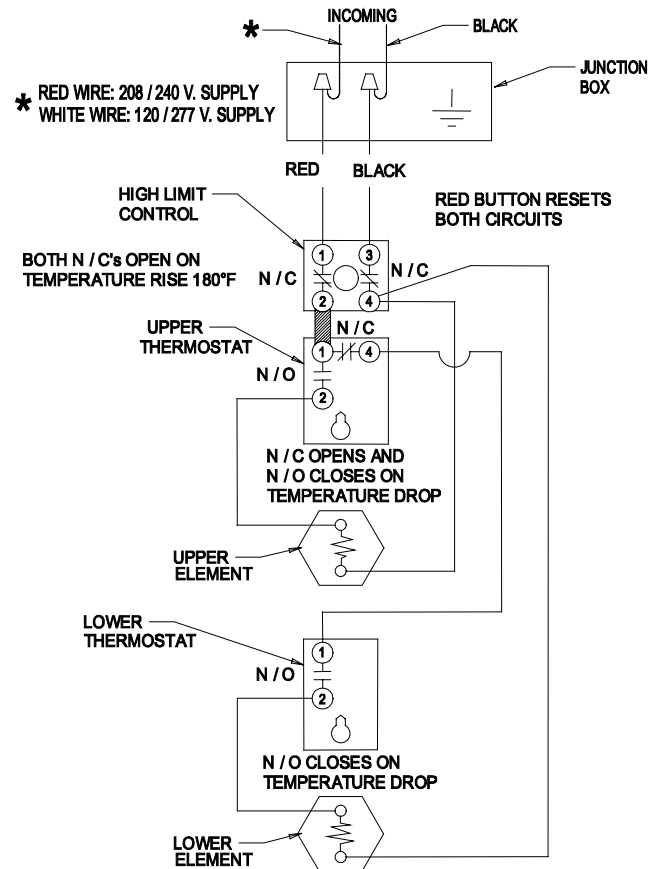

WATER HEATER MUST BE GROUNDED TO THE ELECTRIC SUPPLY SERVICE.

### FILLING TANK

1. Close the drain valve, and then open a hot water faucet.
2. Open the cold water supply valve.
3. When water runs out of the hot faucet, the tank is full.
4. Check the system for leaks.

**NOTE: When filling, avoid water spillage. Do not allow the insulation of the heater to get wet as water can cause electrical malfunction.**

### DRAINING TANK (completely)

If the power is to be turned off during the cold season and the tank is exposed to freezing temperatures, the water heater must be drained. Water will expand when it freezes and can damage the heater.

Completely drain as follows:

1. Make sure the electrical supply to the water heater is "OFF".
2. Turn off cold water supply.
3. Connect a garden hose to the end of the drain valve and direct this to a point lower than the heater.
4. Open a hot water faucet.
5. Open the drain valve on the heater – drain, keeping the drain valve open during the shutdown period.
6. To refill the heater, see 'Filling Tank' section.

### INSTALLATION CHECK LIST

Check Here

1. Are the fuse and wire sizes correct?
2. Is the certified relief valve installed?
3. Are you sure that in case of water leakage, the building, furniture, carpeting or other property will not be damaged?
4. Has the relief valve been piped to a suitable drain point?
5. Is the relief valve discharge unobstructed?
6. Is the heater completely filled with water?
7. Is the cold supply valve open?

If the answer to the above are yes, turn on the power and enjoy all the hot water you need, all the time.

### RELIEF VALVE REQUIREMENTS

**CAUTION** To reduce the risk of excessive pressures and temperatures in this water heater, install temperature and pressure protective equipment required by local codes. It should be no less than a combination temperature and pressure relief valve certified by a nationally recognized testing laboratory that maintains periodic inspection of production of listed equipment or materials, as meeting the Requirements for Relief Valves and Automatic Gas Shut-off Devices for Hot Water Supply Systems, ANSI Z21.22-latest edition.

This valve must be marked with a maximum set pressure not to exceed the marked MAXIMUM working pressure of the water heater (150 PSI). Install the valve into an opening provided and marked for this purpose in the water heater, and orient it or provide tubing so that any discharge from the valve will exit only within 6 inches above, or at any distance below the structural floor and cannot contact any live electrical part. The discharge opening must not be blocked or reduced in size under any circumstances.

The end of the relief pipe opening should terminate near a floor drain or other suitable location not subject to blocking or freezing. DO NOT thread, plug or cap the relief pipe opening.

**FAILURE TO INSTALL A LISTED 3/4" TEMPERATURE - PRESSURE RELIEF VALVE WILL RELEASE THE MANUFACTURER FROM ANY CLAIM WHICH MIGHT RESULT FROM EXCESSIVE TEMPERATURES AND PRESSURES.**

### TEMPERATURE & PRESSURE RELIEF VALVE

Inspect the relief valve annually to ensure proper operation. This involves opening the valve to check that water is able to flow freely, and that there are no blockages. **Warning: THE WATER WILL BE HOT** and its flow can be forceful. Provide a bucket or drainage for the expelled water. Lift the lever and let it snap shut. The water should stop immediately.

If the valve does not function properly, it **MUST** be replaced. In systems where the relief valve discharges periodically, this may be due to thermal expansion causing pressure build up. See 'Pressure Build-Up (Thermal Expansion)' section.

### CAUTION

**FOR YOUR SAFETY, BE AWARE THIS WATER HEATER IS CAPABLE OF PRODUCING HOT WATER AT A TEMPERATURE SUFFICIENT ENOUGH TO CAUSE SCALDING INJURY. READ INSTRUCTIONS CAREFULLY BEFORE OPERATING THIS UNIT. INCREASING THE THERMOSTAT SETTING ABOVE THE PRE-SET TEMPERATURE MAY CAUSE SEVERE BURNS AND CONSUME EXCESSIVE ENERGY. HOTTER WATER INCREASES THE RISK OF SCALD INJURY.**

**150°F (66°C) – 2 SECONDS**

**140°F (60°C) – 6 SECONDS**

**130°F (54°C) – 30 SECONDS**

### TEMPERATURE ADJUSTMENT

In order to reduce the risk of scald injury, thermostats are factory set at 120°F (49°C). The thermostats operate automatically. They can be adjusted to provide warmer or cooler water temperature. The setting of 120°F (49°C) has been proven to be most satisfactory from the standpoint of operational costs and safety. We recommend you keep the thermostats adjusted to 120°F (49°C). If adjustments are made set both thermostats to the SAME setting (if applicable).

### TEMPERATURE LIMIT CONTROL

For safety, a non-adjustable high limit temperature switch will shut off the power when excessive water temperatures are reached. This switch must be re-set manually. See 'Trouble-Shooting' section.

**WARNING** BEFORE ATTEMPTING ANY ELECTRICAL REPAIRS OR REPLACEMENTS, TURN OFF POWER TO THE WATER HEATER. CHECK WITH A VOLTAGE TESTER AT TERMINAL 1 AND 3 OF THE LIMIT CONTROL THAT POWER IS INDEED OFF. FAILURE TO DO SO MAY RESULT IN ELECTRIC SHOCK AND/OR ELECTROCUTION OF THE PERSON DOING THE WORK.

If water temperature adjustment is required:

1. Turn the electrical supply to the water heater "OFF".
2. Remove the access door(s), and turn back insulation.
3. Adjust the thermostat(s) to the water temperature desired (if a two-thermostat system exists, set both thermostats at the same temperature).
4. Repack the insulation and replace access door(s).
5. Turn the electrical supply to the water heater "ON".

### ELEMENT REPLACEMENT

1. See 'Draining Tank' section to remove water from the heater.
2. Turn the electrical supply to the water heater "OFF".
3. Remove the access door(s), and turn back insulation.
4. Disconnect wires from heating element terminals.
5. Unscrew the element using a 1/2" socket wrench or tool number S1008, available from your water heater distributor.
6. Replace element with new one, taking care that sealing gasket is in the groove of element flange.
7. Re-connect wiring, and replace Di-Electric shields.
8. Repack insulation over thermostat(s), and replace access door(s).
9. Fill tank with water **BEFORE** turning **ELECTRICITY** on. See 'Filling Tank' section.

### THERMOSTAT REPLACEMENT

1. Turn the electrical supply to the water heater "OFF".
2. Remove the access door(s), and turn back insulation.
3. Disconnect wires from thermostat(s).
4. Lift prongs off bracket and slide thermostat up and out.
5. Replace in reverse order, taking care that thermostat(s) is **flush against the tank**.
6. Repack insulation over thermostat(s), and replace access door(s).
7. Turn the electrical supply to the water heater "ON".

### CATHODIC PROTECTION: ANODE MAINTENANCE

Your water heater has been supplied with an anode rod that protects the tank from corrosion. As the rod works, it slowly dissolves over time and must be replaced. If the anode is less than 3/8" diameter, or any exposed bare core, replace. Depending on water conditions, an anode can last from one to ten years. Many localities treat their water, which can have significant effect on the life of your heater. Water conditioning such as over softening can accelerate the rate at which the anode rod is consumed. Rapid depletion can leave a heater unprotected causing a premature failure. As with any water heater, it is good practice to check the anode annually to see if it needs replacing.

### ANODE INSPECTION / CHANGE

1. Turn the electrical supply to the water heater "OFF".
2. Close the cold inlet supply valve.
3. Open a hot water tap supplied by the heater. (CAUTION: Water will be hot).
4. See 'Draining Tank' section to remove enough water to empty the piping system.
5. Using a 1 1/16" socket, remove anode and inspect or replace as required.
6. To refill the heater, see 'Filling Tank' section.

**WARNING** Operating a water heater without an actively working anode rod will void the warranty.

### TANK CLEAN-OUT

1. A clean-out opening is provided on certain models for periodic cleaning of the tank. Power supply must be shut off and the heater drained before opening the clean-out.
2. To clean heater through the clean-out opening, proceed as follows:
  - a) Remove outer door from side of the casing.
  - b) Peel back the insulation covering the clean-out flange.
  - c) Remove the six (6) hex head screws securing the tank clean-out plate and remove the plate.
  - d) Remove lime, scale or sediment using care not to damage the glass lining of the tank.
  - e) Inspect the clean-out gasket, if it shows signs of wear, a new gasket is required.
  - f) Install the clean-out plate. Be sure to draw plate up tight by tightening screws securely.
  - g) Position the insulation, and replace the door.

### TROUBLE-SHOOTING

Follow the preceding instructions carefully and your heater should provide long and trouble free service. If problems do arise however, the following will be of assistance.

### NOT ENOUGH OR NO HOT WATER

1. Make sure the electrical supply to the water heater is "ON".
2. Check for loose or blown fuses and loose connections in the water heater circuit.
3. If the water was too hot and is now cold, the high limit temperature switch may have operated. To reset this, proceed as follows:
  - a) Turn the electrical supply to the water heater "OFF".
  - b) Remove the access door then turn back the insulation.
  - c) Reset the control by pushing in the red button marked 'RESET'.
  - d) Repack the insulation then replace access door.
  - e) Turn the electrical supply to the water heater "ON".
4. The capacity of the tank may have been exceeded by large demands of hot water. Wait at least one hour then check for hot water at normal hot water faucet.
5. The incoming cold water may be colder because it is winter. If so, it will take longer to heat the water.
6. If none of the above result in adequate hot water, call a service person.
7. If there is no HOT water, check the upper element.
8. If there is limited HOT water, check the lower element.
9. If water is LUKEWARM check for proper incoming voltage.

### WATER LEAKAGE IS SUSPECTED

1. Check all pipes and fittings for leaks, including the drain valve, element(s) and relief valve.
2. See if the apparent leakage might be condensation. In warm or humid locations, condensation can accumulate and run from the heater and piping.
3. If leakage is from the relief valve discharge pipe, it may represent a normal condition. Call a service person to check the valve carefully.
4. If you cannot identify or correct the source of leakage:
  - a) Turn off electrical supply to the heater.
  - b) Close the cold water inlet valve to the heater.
  - c) Open a hot water faucet.
  - d) Contact a qualified plumber or service person.

### WATER IS TOO HOT

Adjust the thermostats to a lower setting. See 'Temperature Adjustment' section. It is imperative that the thermostat is flush against the tank. See 'Thermostat Replacement' section.

### HOT WATER ODOUR

On occasion, and depending on your location, hot water may develop a strong odour. This can be especially problematic in regions where the water contains some sulphur, which results in hot water having a "rotten egg" smell. If this occurs, drain the system completely, flush thoroughly and refill. If the problem persists, the anode rod may need to be changed from magnesium to one made of aluminum. In certain cases chlorinating and flushing of the water heater may be required. Contact your dealer or water supplier.

### DISCOLORED WATER

- Water rich in iron or other minerals can produce red or brown staining. Heating water generally worsens this situation.
- Black water can be an indication of organic contaminants in the water supply. This can be problematic in areas where the water is obtained from surface or contaminated sources. Organic particles can develop bacterial growth, causing potential health hazards. Contact your water supplier for proper filtration or water conditioning equipment. For bacterial problems contact your local health authority. Also see 'Hot Water Odour' section.
- A sudden appearance of rusty water can indicate the anode rod has been depleted. The remaining steel core wire may be corroding, releasing iron particles into the water. Inspect and replace as necessary. Also see 'Cathodic Protection: Anode Maintenance' section.

### WATER HEATER MAKES NOISE

Sediment, sand or scale can accumulate resulting in "rumbling" or a "hissing" noise. Water heaters need to be flushed regularly to minimize buildup. Severe accumulations can cause premature failure of the water heater elements.

### EXTENDED NON USE SERVICE

**CAUTION** Hydrogen gas is produced in a hot water system served by this heater that has not been used for a long period of time (generally two (2) weeks or more). Hydrogen gas is extremely flammable. To reduce the risk of injury under these conditions, it is recommended that the hot water faucet be opened for several minutes at the kitchen sink before using any electrical appliance connected to the hot water system. Use caution in opening faucets. When hydrogen is present, there will probably be an unusual sound such as air escaping through the pipe as the water begins to flow. There should be no smoking or open flame near the faucet at the time it is open.

## PRESSURE BUILD-UP (THERMAL EXPANSION)

During the heating cycle of the water heater, the water expands creating a pressure build-up in the plumbing system. If the pressure exceeds 150 PSI, water will come out of the valve. This is a normal safety function of the T&P valve. The water supply meter may have a check valve or back flow preventer inside. This can increase the possibility of pressure build-up. Causes of discharge can be thermal expansion, excess system pressure, too high a temperature setting on the thermostat or something in the water heater causing excess temperatures in the heater.

**Thermal Expansion:** When water is heated it expands. For example, in a 40-gallon water heater, water being heated to its thermostat setting will end up expanding by approximately 1/2 gallon. This extra volume created by the expansion has to go somewhere or pressure will dramatically increase, such as when water is heated in a closed system. A good indication of thermal expansion is when the T&P valve releases about one cup of water for every 10 gallons of heater capacity with each heating cycle. The T&P valve is functioning properly when it relieves pressure caused by thermal expansion, but frequent relief can result in a build up of natural mineral deposits on the valve seat, rendering the valve inoperative. Should this happen, the T&P valve needs to be replaced.

To prevent this 'T & P VALVE' from discharging hot water, the loss of energy and reduce the possible build-up of lime in the 'T & P VALVE' there are two (2) recommendations:

**OPTION 1:** Install a 125 PSI Pressure Relief (only) valve in the cold water supply line. Make sure that the discharge of this valve is directed to a drain to prevent water damage and it is protected from freezing,

**OR**

**OPTION 2:** Install an expansion tank on the cold water supply line. For every 50 U.S. gallons of stored water, the expansion tank must have a minimum capacity of 1.5 U.S. gallons.

**Temperature Relief:** The T&P valve will discharge varying amounts of water, but typically more than you would experience from thermal expansion. Check the temperature in relation to the setting on the thermostat dial. A malfunctioning thermostat could cause the water to get too hot.

Alternate location of pressure relief valve

OPTION 2

Location of pressure relief and \ or expansion tank if a check valve or pressure reducing valve is in the cold water supply to the house.

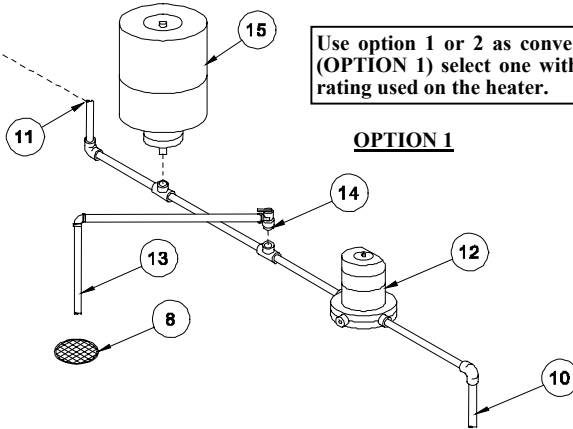
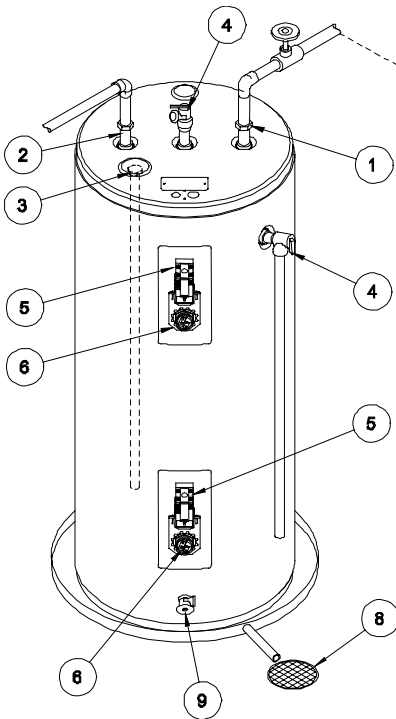

Use option 1 or 2 as convenient. If a pressure relief valve is used (OPTION 1) select one with a setting 25 psi below the relief valve rating used on the heater.

OPTION 1

### SPACESAVER™ MODELS (SIDE OUTLET) ONLY

#### NOTE TO INSTALLERS:

A bent tube (as shown) is installed for the hot water outlet on side outlet water heaters to ensure a maximum of hot water supply.

This fitting must be aligned properly.

The 'line' on the fitting must be oriented pointing up. When in correct position, the hot water is drawn from the highest point in the tank.

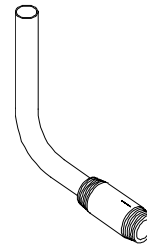

Refer to pressure relief \ expansion tank schematic above.

1. Cold water inlet
  2. Hot water outlet
  3. Anode(s)
  4. Temperature and pressure relief valve\*
  5. Thermostat
  6. Element
  7. Access door – not illustrated
  8. Floor drain
  9. Drain valve
  10. Water supply to meter
  11. Water supply to home
  12. Water meter with backflow preventer
  13. Overflow
  14. Pressure relief valve
  15. Expansion tank
- \*Items to be supplied by installer

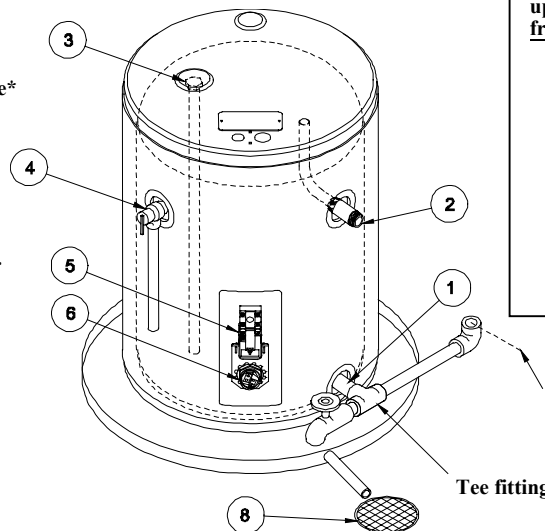

Tee fitting and drain valve

# ~ Certificate of Warranty ~

See Rating Label Serial Number prefix for Warranty Code. Reduced warranty period applies to Newfoundland.

<b>Warranty Code:</b>	<b>P</b>	<b>R</b>	<b>S</b>	<b>T</b>	<b>U</b>	<b>V</b>	<b>W</b>	<b>Y</b>
<b>Standard Warranty Years:</b>	<b>3</b>	<b>5</b>	<b>6</b>	<b>7</b>	<b>8</b>	<b>9</b>	<b>10</b>	<b>12</b>
<b>Reduced Warranty Years:</b>	<b>2</b>	<b>3</b>	<b>3</b>	<b>5</b>	<b>5</b>	<b>5</b>	<b>5</b>	<b>7</b>

**For its GSW and John Wood water heaters and storage boosters ("Unit"), GSW Water Heating ("GSW")** warrants that, upon receipt of a properly verified Warranty claim within the Warranty Period, it will, at its election, repair or replace: units which leak; parts which are defective in material or workmanship, subject to the terms and conditions set forth in this certificate. GSW Units/parts must be replaced with GSW or John Wood product to be eligible for Warranty. This Warranty is available to the original owner for a Unit installed within the boundaries of continental United States, Canada, or their territories. **Consumers must retain point of sale proof of purchase to validate warranty entitlement.** This Warranty does not cover components not manufactured by GSW, such as oil burners, which carry the warranty given by the manufacturer thereof, which warranty GSW will make available, to the extent permitted by the manufacturer, without recourse to GSW.

**THERE ARE NO WARRANTIES WHICH EXTEND BEYOND THE DESCRIPTION ON THE FACE HEREOF. THIS EXPRESS WARRANTY IS, WHERE PERMITTED BY LAW, IN LIEU OF AND EXCLUDES ALL OTHER CONDITIONS, WARRANTIES, GUARANTEES, REPRESENTATIONS, OBLIGATIONS OR LIABILITIES OF GSW OF ANY NATURE OR KIND, EXPRESS OR IMPLIED, HOWEVER ARISING (WHETHER BY CONTRACT, CONDUCT, STATEMENT, STATUTE, NEGLIGENCE, PRINCIPLES OF MANUFACTURER'S LIABILITY, OPERATION OF LAW OR OTHERWISE) WITH RESPECT TO THE UNIT OR ITS FITNESS FOR A PARTICULAR PURPOSE, MERCHANTABILITY, INSTALLATION, OPERATION, REPAIR OR REPLACEMENT. GSW EXPRESSLY DISCLAIMS ANY AND ALL IMPLIED WARRANTIES. IN NO EVENT WILL GSW'S LIABILITIES EXCEED THE COST OF THE DEFECTIVE PART(S) NOR LEAKING INNER TANK. GSW WILL NOT PAY FOR ANY TRANSPORTATION, LABOUR, INSTALLATION, OR OTHER INCIDENTAL COSTS ASSOCIATED WITH THE REPAIR OR REPLACEMENT OF A DEFECTIVE PART OR HEATER.**

This warranty and GSW's obligations shall be construed and determined in accordance with the laws of both the Province of Ontario, and of Canada in force therein. This Warranty does not affect specific legal rights of a consumer under applicable law, except to the extent that such rights may be waived or replaced, and the provisions hereof are deemed to be amended to the extent necessary. The unenforceability of any provision of this Warranty shall not affect the remaining provisions. Any and all repair and/or replacement of part(s) or Unit are the sole and exclusive remedy available against GSW.

## LIABILITY OF GSW COVERED BY THIS WARRANTY IS CONDITIONAL UPON THE FOLLOWING:

1. The Unit shall be installed in accordance with all manufacturers' instructions, all applicable equipment and building codes, ordinances and regulations.
2. The Unit must not be installed where water damage can result from a leak, while provision(s) shall be made for directing any water escaping from the Unit, to a drainpipe. As all Units may eventually leak, you must protect against any potential water damage. GSW accepts no responsibility for such damage, nor any incidental or consequential loss, nor damage(s) related thereto, suffered by the owner of the unit nor by any third party.
3. The Unit shall not be installed where it will be exposed to adverse or unusual environmental or corrosive conditions. For example, no warranty extends to Units exposed to: salt; chemicals; exhausts; pollutants or contaminants. Further, no warranty extends to Units affected by fire, freezing or flood, "Acts of God", nor any other contingency beyond the control of GSW.
4. The Unit shall be equipped with a properly operating temperature and pressure relief valve as specified by GSW and applicable codes. The Unit shall be operated at temperatures not exceeding the maximum setting of the thermostat and/or high limit control provided by GSW, and at water pressures not exceeding the pressure reading shown on the Unit.
5. The Unit must be carefully inspected, maintained, and operated in accordance with the manufacturer's instructions. For example, no warranty extends to any Unit operated: without the tank being completely filled with water; without an operating anode; with levels of sediment or lime precipitate which cause failure; in connection to any attachment(s), energy saving device(s), or other means of heating except as approved by GSW for the Unit; other than with potable water without any additives such as salt, chlorine or chemicals, except those added for the sole purpose of rendering the water fit for domestic use.
6. All repairs must be made by qualified personnel who are certified to work on the Unit, using factory approved replacement parts, and the Unit shall not be otherwise modified, altered or improperly repaired. GSW will not assume any expense or liability for unauthorized returns, nor repairs made by unqualified personnel who are not certified to work on the Unit.
7. A properly documented claim shall be received by GSW or one of its authorized dealers, or point of purchase:
  - a) for any defective part within one (1) year; and
  - b) unless otherwise specified below \*, for any leaks that may occur in the Unit's inner tank due to rust, corrosion or other chemical reactions caused by the domestic water supplied to your home, within the period of time shown in table;\*The following are the modified Warranty Periods applicable to leaks in inner tanks:  
\*Residential units installed and used in a commercial application carry a reduced warranty period of one (1) year from date of installation. Any repair or replacement of any part, tank, or Unit under this Warranty will not extend the Warranty Period beyond that calculated from the date of first installation of the original Unit. The date of first installation will be deemed to be the later of the date indicated by the Unit's serial number, or if supplied with the Warranty claim, the sales receipt, or installer's receipt.
8. A claim under this Warranty including the model and serial number of the Unit, proof of date on which the Unit was first installed, and the identity of the defective part(s) for which a claim is being made within 15 days, following discovery of the defect(s), by personal delivery to a GSW authorized dealer, point of purchase, or contact GSW itself at: Technical Support Line 1-800-447-6575 ext 2  
**Address: GSW Water Heating  
A GSW Inc. Company  
599 Hill Street West  
Fergus, ON Canada N1M 2X1**
9. If requested by GSW, information relating to the purchase, transportation operation and installation of the Unit shall be supplied. The defective part(s) or Unit, with all components properly and securely packed, shall be returned transportation pre-paid, to the address designated by GSW in the request. All claims are subject to validation by GSW.

## Free Manuals Download Website

<http://myh66.com>

<http://usermanuals.us>

<http://www.somanuals.com>

<http://www.4manuals.cc>

<http://www.manual-lib.com>

<http://www.404manual.com>

<http://www.luxmanual.com>

<http://aubethermostatmanual.com>

Golf course search by state

<http://golfingnear.com>

Email search by domain

<http://emailbydomain.com>

Auto manuals search

<http://auto.somanuals.com>

TV manuals search

<http://tv.somanuals.com>