

DIRECT VENT GAS FIRED WATER HEATER INSTALLATION AND OPERATING INSTRUCTIONS

Read these instructions thoroughly before starting

TABLE OF CONTENTS

I) Installation & Location	1
II) Replacement Parts Listing	2
III) Vent Connections	3-5
IV) Gas Connections	5
V) Water Pipe Connections	5
VI) Temperature & Pressure	5-6
VII) Lighting & Operating Instructions	7-9
VIII) Service And Maintenance	10
IX) Combo Heating	11
X) Warranty	12

**PLEASE RETAIN THESE INSTRUCTIONS IN A
 SAFE LOCATION FOR FUTURE**

▲ FOR YOUR SAFETY

- **Do not store or use gasoline or other flammable vapours and liquids in the vicinity of this or any other appliance.**
- **Installation and service must be performed by a qualified installer, service agency or the gas supplier.**

▲ WARNING: Improper installation, adjustment, alteration, service, or maintenance can cause injury or property damage. Refer to this manual. For assistance or additional information, consult a qualified installer, service agency, or the gas supplier.

▲ WARNING: If the information in these instructions is not followed exactly, a fire or explosion may result causing property damage, personal injury or death.



WHAT TO DO IF YOU SMELL GAS?

- **Do not try to light any appliance.**
- **Do not touch any electrical switch; do not use any phone in your building.**
- **Immediately call your gas supplier from a neighbor's phone. Follow the gas supplier's instructions.**
- **If you cannot reach your gas supplier, call the fire department.**



WARNING

This water heater must be installed strictly in accordance with the detailed instructions enclosed and local building codes. It must be installed with a proper pressure relief valve which may release water in operation. It is also possible that connections to the water heater, or the water heater itself, may develop leaks. It is therefore **IMPERATIVE** that the water heater be installed so that any water is directed to an adequate drain in such a way that it cannot damage the building, furniture, carpeting or other property subject to water damage. **GSW CANNOT BE HELD RESPONSIBLE** for damage caused by water from the water heater, pressure relief valve, or related fittings where adequate provision to drain such water has not been made. Closets without drains and carpeted areas are examples of unsuitable locations for any water heater.

These instructions have been written as a guide for the proper installation and operation of your water heater.

The manufacturer will not be liable for any damages caused by failure to comply with the installation and operation instructions outlined in the following pages.

INSTALLATION

This heater must be installed by a qualified, licensed gas fitter and according to CAN/CGA-B149 Installation Code or ANSI Z223.1 National Fuel Gas Code and/or local codes. If in doubt, consult your local utility.

LOCATION

Generally, the location selected should be as close to the wall as practical and as centralized with the piping system as possible. Heater should be located in an area not subject to freezing temperatures.

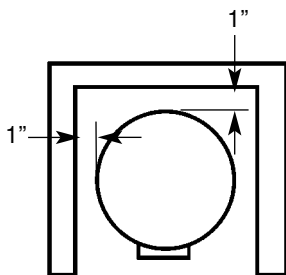

ALCOVE INSTALLATION

The water heater should be located so that the controls and drain are easily accessible. The heater should be located in an area where leakage of tank or connections will not result in damage to the area adjacent to the water heater or to the lower floors of the structure. When such locations cannot be provided, it is recommended that a suitable drain pan be installed under the heater. Such pans should be a maximum of 1 1/2 inches deep and have a minimum length and width of at least 2 inches greater than the diameter of the water heater and should be piped to an adequate drain.

Under no circumstances is the manufacturer to be held liable for any water damage in connection with this water heater.

CAUTION: When this water heater is installed directly on carpeting, carpeting must be protected by a metal or wood panel beneath the appliance extending beyond the full width and depth of the appliance by at least three inches in any direction, or if the appliance is installed in an alcove or closet, the entire floor must be covered by the panel. The panel must be strong enough to carry the weight of the heater when full of water. Failure to heed this warning may result in a fire hazard.

Minimum clearances between the heater and combustible/non combustible materials are 1 inch at the sides and rear; 20 inches from the top of water heater and 1 inch around the vent pipe. A minimum of 3 feet of clearance is required at the front (control) side of the heater for service.

For a closet installation, the door at burner side should be openable and a minimum of 4 inches clearance is needed. Water heater is certified for installation on a combustible floor. (See figure 1.)

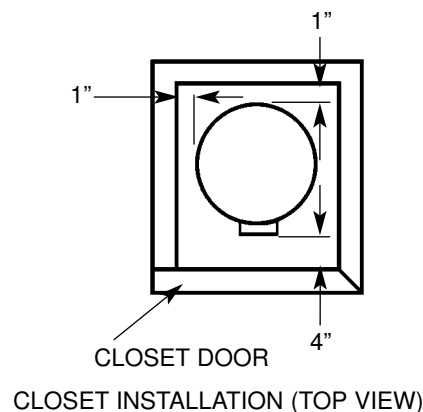
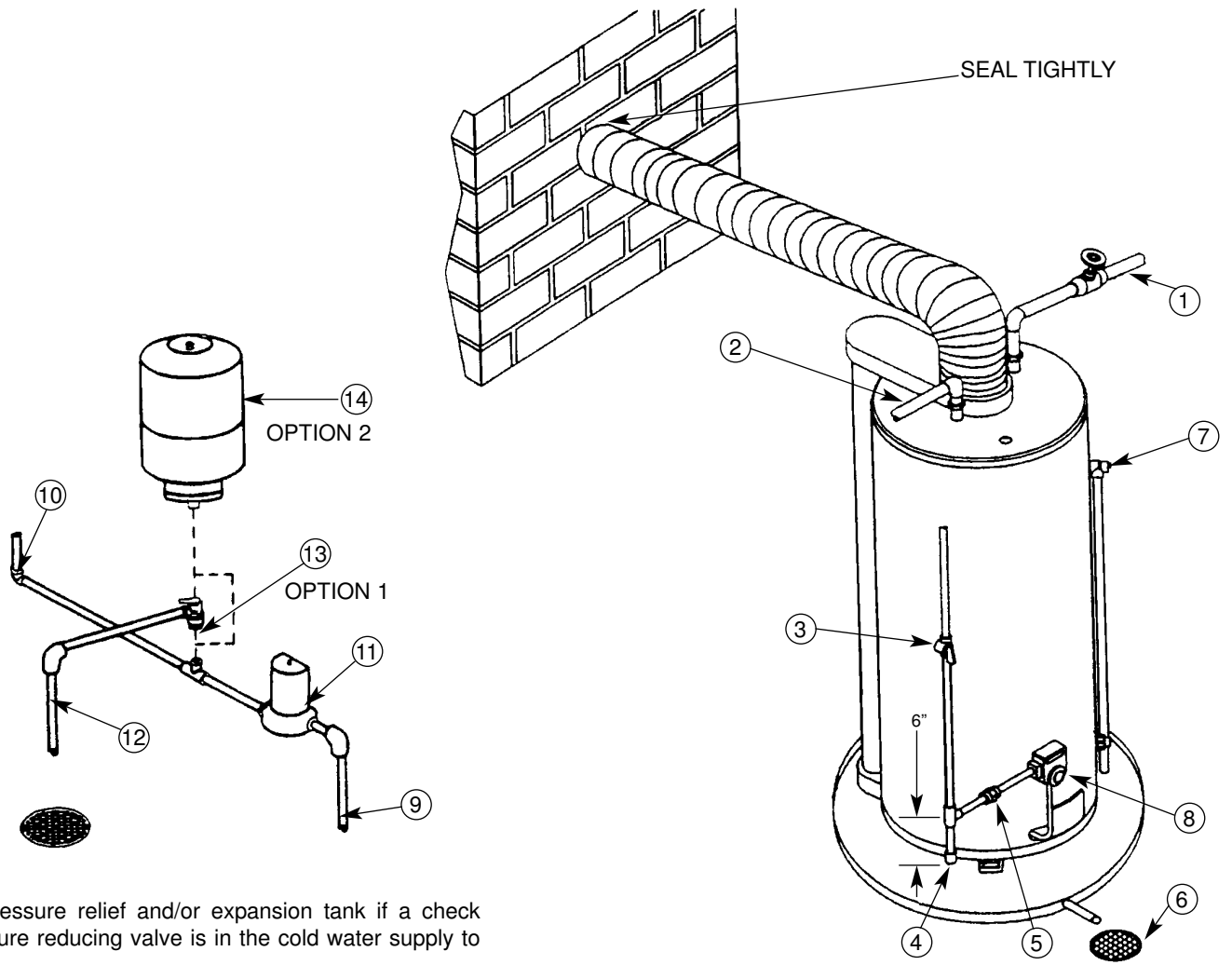

Figure 1



Location of pressure relief and/or expansion tank if a check valve or pressure reducing valve is in the cold water supply to the house.

Use OPTION 1 or 2 whichever is more convenient. If pressure relief valve is used, select one with a setting 25 psi below valve rating at tank.

1. COLD WATER INLET
 2. HOT WATER OUTLET
 3. GAS SUPPLY MANUAL SHUT-OFF VALVE
 4. SEDIMENT TRAP
 5. UNION - GROUND JOINT TYPE
 6. FLOOR DRAIN
 7. TEMPERATURE & PRESSURE RELIEF VALVE
 8. GAS CONTROL
-
9. WATER SUPPLY TO METER
 10. WATER SUPPLY TO HOME
 11. WATER METER WITH BACKFLOW PREVENTER
 12. OVERFLOW
 13. PRESSURE RELIEF VALVE
 14. EXPANSION TANK

Figure 2

Specially For Direct Vent Water Heater:

Make certain to observe the vent location limitations complying with the CAN/CGA-B149 Installation Code or ANSI Z223.1 National Fuel Gas code and/or local codes. There are some important issues shown in Figure 3.

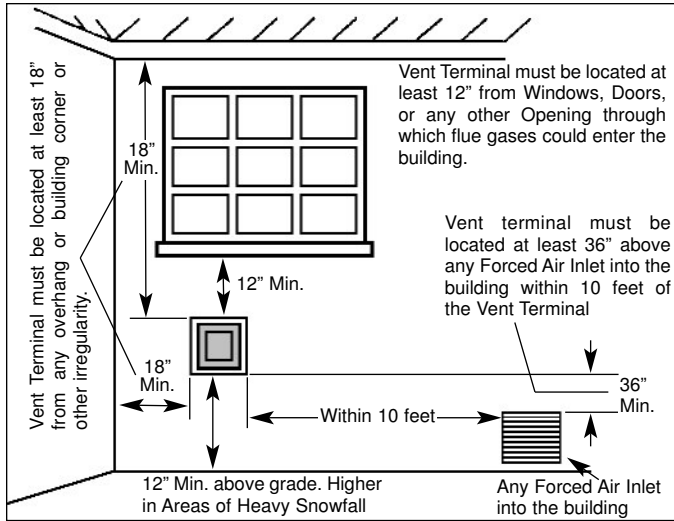

Figure 3 - Vent Location Limitations

For a second or more direct vent unit, the distance between vent terminals must have a minimum of 1 foot.

INSPECT SHIPMENT — There may be hidden damage caused by transit. Check to be certain all parts of the venting system, as shown in Figures 3A through 3M, are present. Inspect the upper and lower air inlet boxes, rear air tube and all parts of the venting system.

CAUTION

If there are any damaged parts, DO NOT install this water heater. Report any shortage to your distributor or damage to your carrier.

Note: The four fasteners that are required to secure the vent terminal to the exterior wall are not provided. These should be screw type (not nails) chosen for the type of construction and obtained locally.

CAUTION

Cut edges of corrugated (flex) pipe are extremely sharp. Wear gloves when handling.

VENT CONNECTIONS - After the location for the vent terminal has been selected as outlined in Figure 3, use the following illustrations for installation:

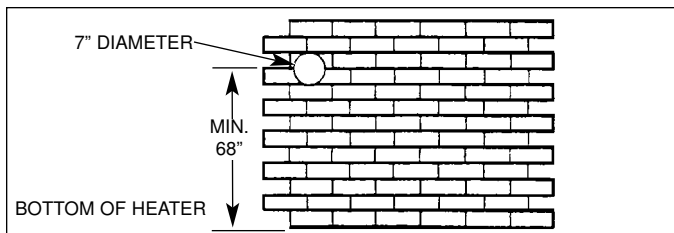

Figure 3 A - Locating Clearance Hole for Vent.

Cut a clearance hole, approximately 7 inches in diameter, through the exterior wall for the vent assembly. The minimum height should not be less than 68" from the hole center to bottom of water heater. The maximum height

recommended is 90" or in compliance with figure 3M.

*Where the wall is combustible and the wall thickness is over 14", 1 inch clearance to combustible materials around the terminal pipe is needed. The first 14" is zero clearance.

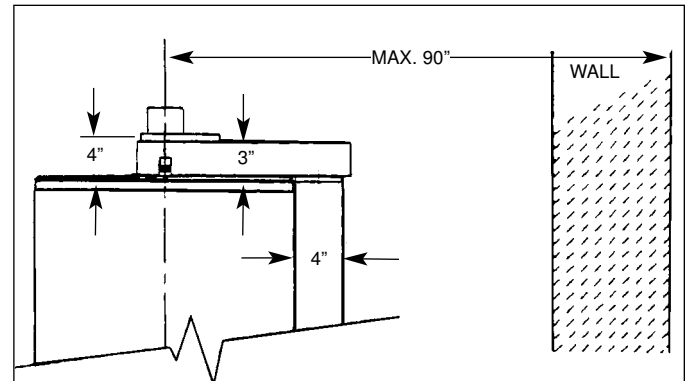

Figure 3 B - Moving Water Heater To Its Final Installed Location.

Move the water heater to its final installed location. Make certain clearances from combustible material are observed. The maximum distance from center of water heater to outside wall should not be longer than 90".

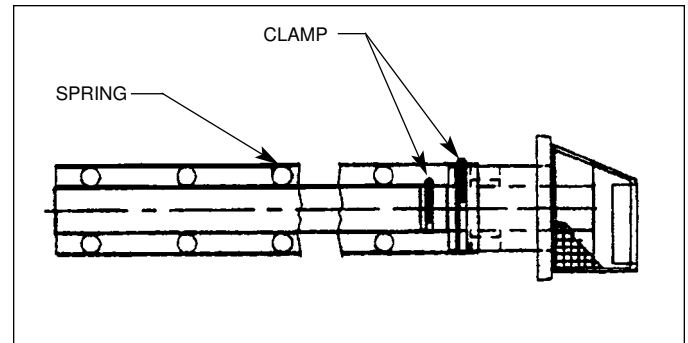

Figure 3 C - Vent Assembly.

The vent pipe and terminal are assembled by the manufacturer as shown in figure 3C. There are springs fastened inside the corrugated pipe. When the vent pipes are pulled to a required length, the distances between the springs will still be equally spaced.

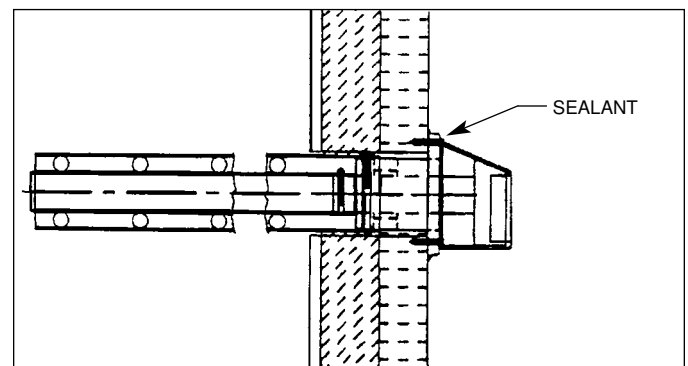

Figure 3 D - Securing Vent Termination Assembly To The Exterior Wall.

Introduce the 6" pipe through the clearance hole from exterior wall then secure the vent terminal to the exterior wall with 4 screw anchors appropriate for the type of wall construction. Caulk the junction of the vent terminal base plate and the exterior wall with exterior type silicone sealant.

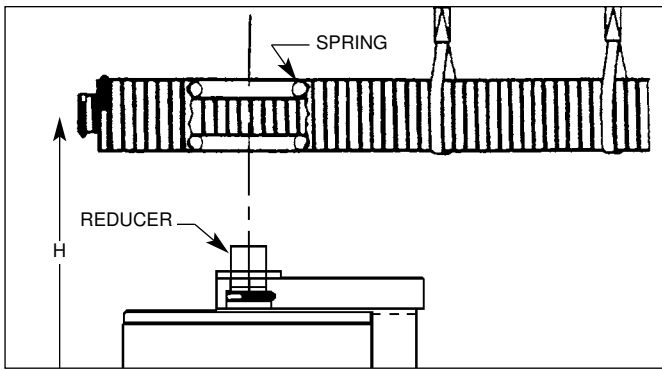

Figure 3 E - Pull the 3 1/8" and 6" Corrugated Pipe Toward the Water Heater Individually.

1. Pull the 3 1/8" corrugated pipe toward the water heater and leave some length over the water heater's center for bending.
2. Pull the 6" corrugated pipe toward the water heater and leave it 1" shorter than 3 1/8" pipe.
3. Make sure there are two springs evenly spaced at the bend in the pipe.
4. Use metal hangers to keep vent pipe level or with a slope upward from the heater to terminal.

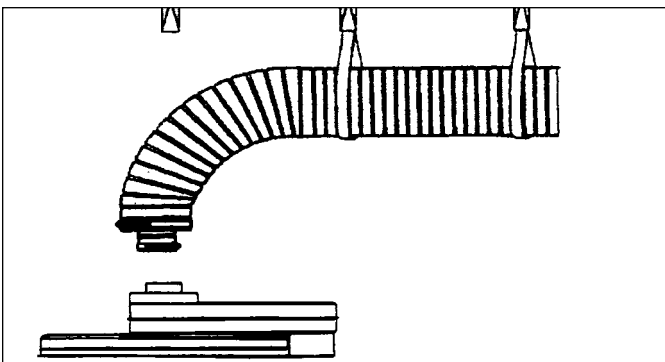

Figure 3 F

Bend the 3 1/8" and 6" corrugated pipe all together toward the water heater's flue connection.

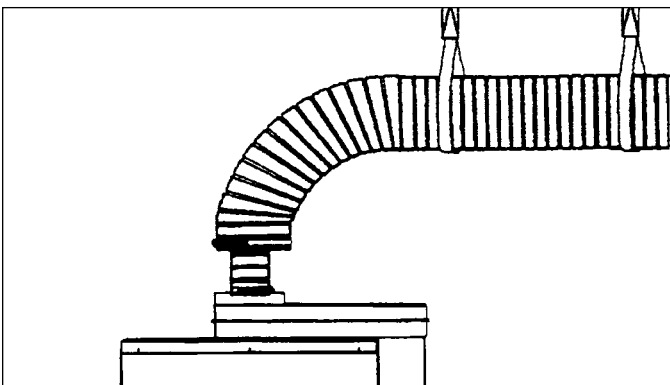

Figure 3 G

Pull and connect the 3 1/8" corrugated pipe to the water heater's flue tube reducer with hi-temp red silicone and gear clamp. Make sure this connection is tight and leak proof.

*The sealant between 3 1/8" corrugated pipe and water heater's flue tube reducer must be hi-temp red silicone or other material suitable for 600°F continuous service.

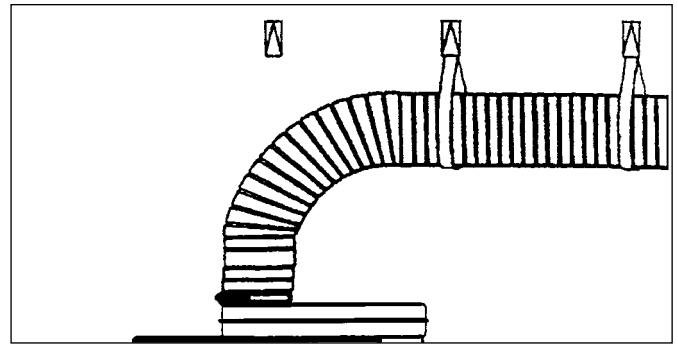

Figure 3 H

Apply silicone around 6" collar on air manifold box. Pull corrugated vent tube all the way on to collar and secure with one sheet metal screw (approx. 3/4") up from edge of vent tube. Pull gear clamp past screw and tighten.

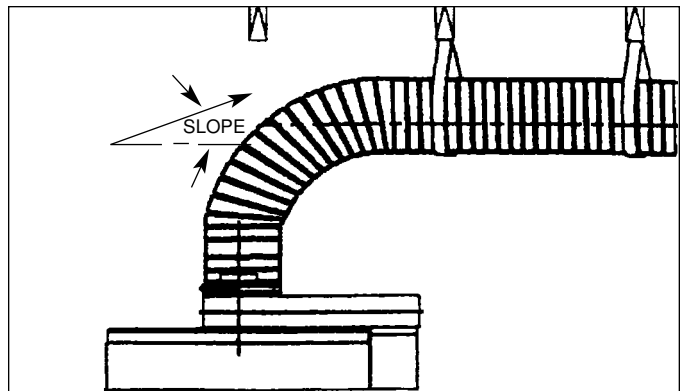

Figure 3 J

Check the vent pipe's level or slope again, and adjust if required.

Offset vent pipe Arrangement

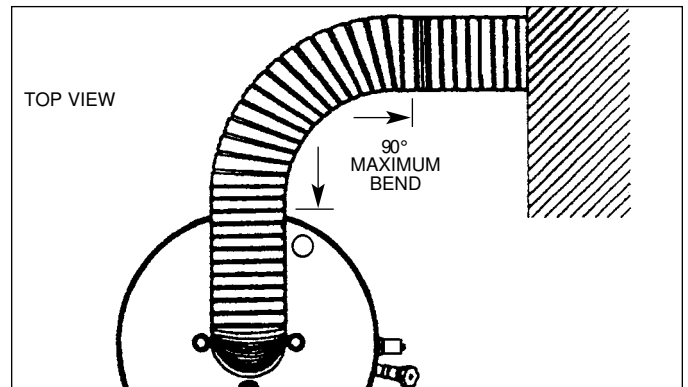

Figure 3 K - CONDITION 1

Where a straight vent pipe arrangement is impossible, a horizontal 90 degree maximum bend can be made. Use the water heater casing outer diameter as a template to form the corrugated pipe.

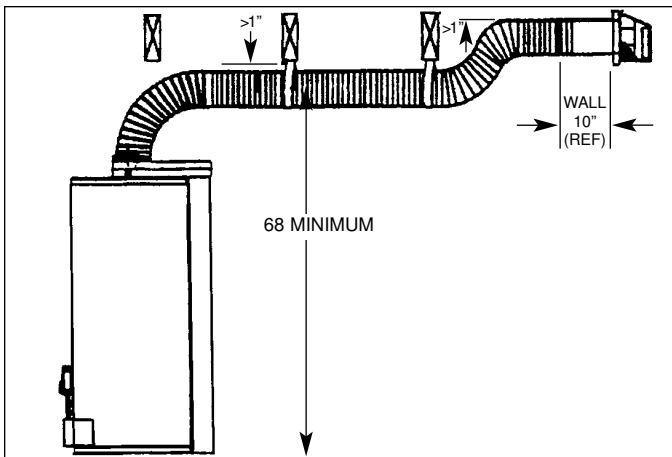

Figure 3 L - CONDITION 2

Where floor joists impede venting, a rise to complete the vent termination is possible. All installations require 1" clearance to combustibles.

Note:

- A. The maximum horizontal vent pipe length of 90" minus wall thickness should be considered when installing an offset vent arrangement.
- B. **Do not Combine condition (3K) with condition (3L) in the same installation.**

High Rise Vent Pipe Arrangement

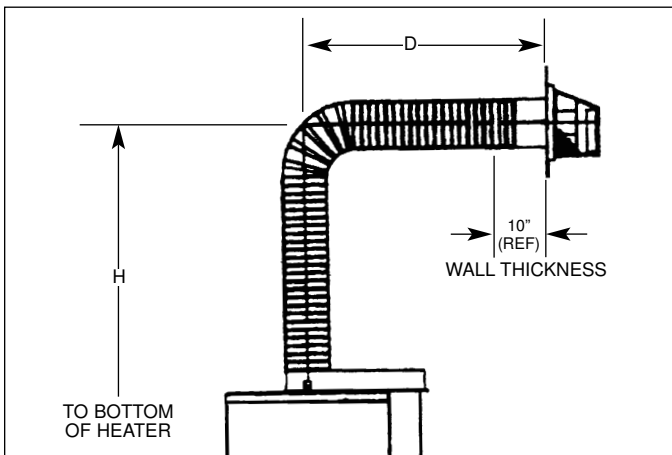

Figure 3 M

When the height H (From vent terminal center line to bottom of heater) is over 90", it is a high rise vent pipe arrangement. The minimum distance "D" from the center of the water heater to the outside wall surface is 22", and the maximum height of "H" is 12 feet.

GAS CONNECTIONS

Install the gas piping as indicated in Figure 2. Use only new pipe and fittings with sound, clean-cut pipe threads. Sealing compound must conform to the applicable code for pipe sealing compound approved for use with natural gas and propane. Use gas piping of adequate sizing to ensure full gas input. All piping must comply with all local codes. In the absence of local codes, piping must comply with the rules stated by the applicable National Fuel Gas Codes. The final connection to the gas control valve is made using 1/2" N.P.T. pipe.

Inlet gas pressure to the appliance must not exceed the gas pressures marked on the rating plate; 7" W.C. for natural gas, 14" W.C. for L.P. gas. The minimum supply pressure for the purpose of input adjustment is 1" above manifold pressure.

The appliance and its individual shutoff valve must be disconnected from the gas supply piping system during any pressure testing of that system at test pressure in excess of 1/2 psig (3.5 kPa).

The appliance must be isolated from the gas supply piping system by closing its individual manual shutoff valve during any pressure testing of the gas supply piping system at test pressures equal to, or less than 1/2 psig (3.5 kPa).

The appliance and its gas connection must be leak tested before placing the appliance in operation. It is important to have a readily accessible manual shutoff valve in the gas line supplying the heat close to the heater. A drip leg must be installed ahead of the gas control valve to help trap sediment and foreign material.

A ground-joint union must be installed ahead of the gas valve to permit easy removal of the unit. All leak testing must be done with a soapy water solution.

NEVER USE A MATCH OR OPEN FLAME TO TEST FOR GAS LEAKS. A FIRE OR EXPLOSION COULD RESULT.

WATER PIPING

Pipes and fittings should be installed in compliance with the installation drawing. Check for dip tube in cold water fitting before connection of hot and cold water lines. Show where the water shut-off valve for the water heater is installed so that the owner knows where and how to shut the water off. It is recommended that such a valve be located in close proximity to the cold water inlet of the water heater.

Connect the cold water supply (3/4 NPT) to the fitting marked "COLD", the hot water outlet (3/4 NPT) to the fitting marked "HOT". Do not apply heat to either of these fittings as they contain a nonmetallic tube. When making these connections, always use a good grade of pipe joint compound and be certain that all fittings are tight. See installation drawing (FIGURE 2).

After piping has been installed, allow tank to fill with water and check connections for leaks. To insure complete filling of the tank, allow air to exit by opening the nearest hot water faucet until a constant flow of water is obtained.

TEMPERATURE & PRESSURE RELIEF VALVE

For protection against excessive pressure and/or temperatures, a temperature and pressure relief valve has been installed in the water heater.

ANY REPLACEMENT VALVE MUST NOT EXCEED THE TEMPERATURE AND PRESSURE RATING.

FAILURE TO INSTALL AND MAINTAIN A NEW, PROPERLY LISTED TEMPERATURE AND PRESSURE RELIEF VALVE WILL RELEASE THE MANUFACTURER FROM ANY CLAIMS WHICH MIGHT RESULT FROM EXCESSIVE TEMPERATURE OR WATER PRESSURE.

Pressure rating of the valve must not exceed the working pressure shown on the rating plate of the water heater. The discharge capacity must be equal to or greater than the input to the water heater. Temperature and Pressure Relief valve piping must terminate 6 inches, no more than 12" (reference the applicable code) above a floor drain or external to the building. Do not thread, cap, or plug the end of this discharge line. Be certain that no contact is made with any live electrical part. Do not connect discharge line directly to drain. See Figure 2. To prevent bodily injury, hazard to life or damage to property, the relief valve must be allowed to discharge water in the event of excessive temperature or pressure developing in the water heater. The function of the temperature and pressure relief valve is to discharge water in quantities should circumstances demand. If the discharge pipe is not directed to drain as shown in Figure 2 or other suitable means, the water flow may cause property damage.

The discharge line:

- 1) must not be smaller than the outlet pipe size of the relief valve,
- 2) must not be plugged or blocked,
- 3) must be material capable of withstanding 210°F without distortion,
- 4) must be installed so as to allow complete drainage of both temperature and pressure relief valve,
- 5) must terminate at an adequate drain, and
- 6) must not have any valve between the relief valve and the water heater.

WARNING

Do not attempt to operate this water heater with the cold water inlet valve closed. Manually operate the Temperature and Pressure Relief valve at least once a year. Standing clear of the outlet (discharge water may be hot), lift and release the lever handle on the Temperature and Pressure Relief valve to make the valve operate freely.

NEVER OPERATE THE HEATER IF IT IS NOT COMPLETELY FILLED WITH WATER. TO MAKE SURE THE HEATER IS FILLED, OPEN A HOT WATER TAP UNTIL A FULL FLOW OF WATER IS VISIBLE WITH NO AIR ESCAPING.

PRESSURE BUILD-UP IN A WATER SYSTEM

During the heating cycle of the water heater the water expands, creating a pressure build-up in the water system. The water supply meter may contain a check valve or back flow preventer. This will create a closed water system. A temperature and pressure relief valve must be installed on the water heater (150 PSI maximum pressure setting. See temperature and pressure relief valve).

If a water heater is installed in a closed water supply system, the relief valve will discharge water as the volume of water expands with rising water temperatures. This is normal and indicates a normal functioning of the relief valve. **Do not** plug the relief valve. Only if the discharge from the relief valve is continuous or for an extended period of time would this indicate a malfunction. Have the operation of the heater checked by a qualified serviceman.

INSTALLATION CHECK LIST

- | | Check Here |
|---|--------------------------|
| 1. Have the vent location limitations and minimum height for vent termination and maximum vent length been checked? | <input type="checkbox"/> |
| 2. Are the terminal and vent pipes installed and sealed properly? | <input type="checkbox"/> |
| 3. Has the gas piping been leak tested? | <input type="checkbox"/> |
| 4. Is there at least a 1" clearance between the water heater and combustible materials, 20" at the top and 1" around the vent pipe? | <input type="checkbox"/> |
| 5. Have you taken steps to prevent water damage in case of leaks? | <input type="checkbox"/> |
| 6. Is the diptube installed in the cold water inlet connection? | <input type="checkbox"/> |
| 7. Is the water heater completely filled with water? | <input type="checkbox"/> |
| 8. Does the gas piping conform with the recommendations of your Local Gas Utility Company? | <input type="checkbox"/> |
| 9. Is the vent terminal opening unobstructed? | <input type="checkbox"/> |
| 10. Is a temperature and pressure relief valve installed? | <input type="checkbox"/> |
| 11. Is the drain pipe from the T & P valve unobstructed? | <input type="checkbox"/> |
| 12. Has all plastic and cardboard packaging material been removed from the heater and venting? | <input type="checkbox"/> |

IF the answer to all of the above questions is "YES" proceed with lighting the heater.

VI) LIGHTING AFTER INSTALLATION

WARNING:

TO AVOID POSSIBLE INJURY, FIRE AND EXPLOSION, READ THESE PRECAUTIONS BEFORE ATTEMPTING TO LIGHT OR RE-LIGHT THE PILOT. CHECK THAT THE HEATER IS FILLED WITH WATER AND THE VENTING SYSTEM IS UNOBSTRUCTED.

FOR YOUR SAFETY READ BEFORE LIGHTING

WARNING: If you do not follow these instructions exactly, a fire or explosion may result causing property damage, personal injury or loss of life.

- A.** This appliance has a pilot which must be lighted by hand. When lighting a pilot, follow these instructions exactly.
- B.** BEFORE OPERATING smell all around the appliance area for gas. Be sure to smell next to the floor because some gas is heavier than air and will settle on the floor.



WHAT TO DO IF YOU SMELL GAS

- Do not try to light any appliance.
 - Do not touch any electric switch; do not use any phone in your building.
 - Immediately call your gas supplier from a neighbor's phone. Follow the gas supplier's instructions.
 - If you cannot reach your gas supplier, call the fire department.
- C.** Use only your hand to turn the gas control knob. Never use tools. If the knob will not turn by hand, do not try to repair it, call a qualified service technician. Force or attempted repair may result in a fire or explosion.
 - D.** Do not use this appliance if any part has been under water. Immediately call a qualified service technician to inspect the appliance and to replace any part of the control system and any gas control which has been under water.

BEFORE PROCEEDING WITH LIGHTING INSTRUCTIONS, PLEASE FAMILIARIZE YOURSELF WITH THE CONTROL USED ON YOUR WATER HEATER. REFER TO ILLUSTRATIONS ON PAGES 7 & 8.

WARNING: Should overheating occur or the gas supply fail to shut off, turn off the manual gas valve to the appliance.

LIGHTING INSTRUCTIONS FOR HEATER WITH "SIT" GAS CONTROLS

1. **STOP!** Read all safety labels on the water heater before operation.
2. Rotate the thermostat/control knob located on the gas control clockwise  to the "OFF" position.
3. Wait 5 minutes to clear out any gas. If you smell gas, **STOP!** Follow instruction "B" above on this page. If you do not smell gas, go to the next step.
4. To light heater, remove outer door and remove 2 screws from right side of hinged door.
5. Find pilot. Follow aluminum tube from the underside of the gas control. The pilot is in front of the burner.
6. Turn the thermostat/control knob counterclockwise  to the "PILOT" position.
7. Use a lit match held securely with an extension device, or a long stem igniter. While holding the ignition source at the pilot, depress the pilot button to light the pilot.
8. Keep pilot button depressed for 60 seconds to properly heat thermocouple and activate safety controls.
9. If pilot does not remain lit, repeat steps 7 & 8.
 - If the pilot will not stay lit after several attempts, turn the thermostat/control knob to "OFF" and contact your service technician.
 - If the pilot button does not pop up when released, stop and immediately call your service technician or gas supplier.
10. Once the pilot is established, re-fasten 2 screws to right side of hinged door, then replace the outer door.

WARNING: FAILURE TO PROPERLY SECURE THE INNER DOOR MAY POSE A SAFETY HAZARD.

11. Turn the thermostat control knob counterclockwise  to turn on the heater. Set the knob position to the "LOW" marking to start. Adjust the temperature up as required.

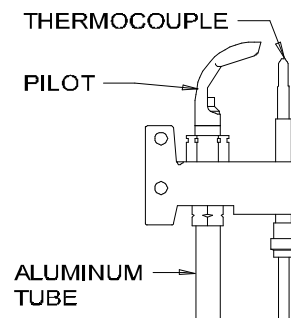
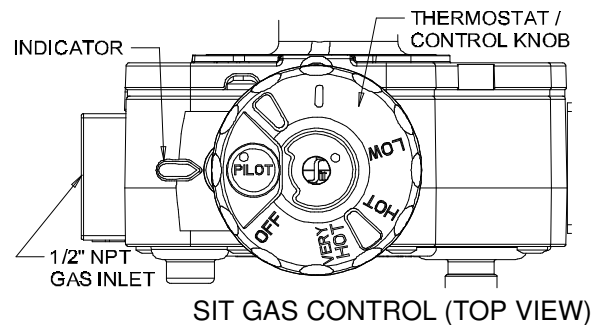

To Turn Off the Gas Control

1. Rotate the thermostat control knob clockwise  to the "OFF" position.

LIGHTING INSTRUCTIONS FOR HEATER WITH "ROBERTSHAW R110" GAS CONTROLS

WARNING: Should overheating occur or the gas supply fail to shut off, turn off the manual gas valve to the appliance.

1. **STOP!** Read all safety labels on the water heater before operation.
2. Set the thermostat to the lowest setting. Rotate dial on front of control counterclockwise. ⤴
3. Rotate gas control knob on top of thermostat clockwise ⤵ to "OFF" position.
4. Wait 5 minutes to clear out any gas. If you smell gas, **STOP!** Follow instruction "B" above on page 7. If you do not smell gas, go to the next step.
5. To light heater, remove outer door and remove 2 screws from right side of hinged door.
6. Find pilot. Follow aluminum tube from the "right-underside" of the gas thermostat. The pilot is adjacent to burner.
7. Turn gas control knob counterclockwise ⤴ to "PILOT" position.
8. Use a lit match held securely with an extension device, or a long stem igniter. While holding the ignition source at the pilot, depress the red pilot set button (upper left) to light the pilot. Continue to hold the pilot set button for about 1 minute after pilot is lit. Release pilot set button and it will pop up. Pilot should remain lit.
 - If knob does not pop up when released, stop and immediately call your service technician or gas supplier.
 - If the pilot will not stay lit after several tries, turn the control knob to "OFF" and call your service technician or gas supplier.
9. Once the pilot is established, re-fasten 2 screws to right side of hinged door, then replace the outer door.

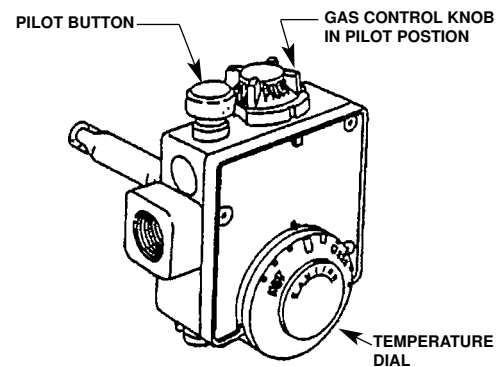

ROBERTSHAW R110 GAS CONTROL

WARNING: FAILURE TO PROPERLY SECURE THE INNER DOOR MAY POSE A SAFETY HAZARD.

10. Turn gas control knob counterclockwise ⤴ to "ON" position.
11. Set the thermostat to desired setting clockwise. ⤵

To Turn Off the Gas Control

1. Set the thermostat dial to the lowest setting. Turn counterclockwise. ⤴
2. Turn gas control knob "OFF". Rotate clockwise. ⤵

LIGHTING INSTRUCTIONS FOR HEATER WITH "ROBERTSHAW 220R" GAS CONTROLS

WARNING: Should overheating occur or the gas supply fail to shut off, turn off the manual gas valve to the appliance.

1. **STOP!** Read all safety labels on the water heater before operation.
2. Rotate gas control knob on top of thermostat clockwise ⤵ to "OFF" position.
3. Set the thermostat to lowest setting.
4. Wait (5) minutes to clear out any gas. If you then smell gas, **STOP!** Follow instruction "B" above on page 7. If you don't smell gas, go to the next step.
5. To light heater, remove outer door and remove 2 screws from right side of hinged door.
6. Find pilot. Follow aluminum tube from the "right-underside" of the gas thermostat. The pilot is adjacent to burner.
7. Turn gas control knob counterclockwise ⤴ to "PILOT" position.
8. Use a lit match held securely with an extension device, or a long stem igniter. While holding the ignition source at the pilot, depress the gas control knob to light the pilot.
9. After pilot lights, keep knob depressed for at least 60 seconds to properly heat thermocouple and activate safety valves.
10. If the pilot does not remain lit wait at least 10 minutes and repeat steps 1-9.
 - If knob does not pop up when released, stop and immediately call your service technician or gas supplier.
 - If the pilot will not stay lit after several tries, turn the control knob to "OFF" and call your service technician or gas supplier.
11. Once the pilot is established, re-fasten 2 screws to right side of hinged door, then replace the outer door.

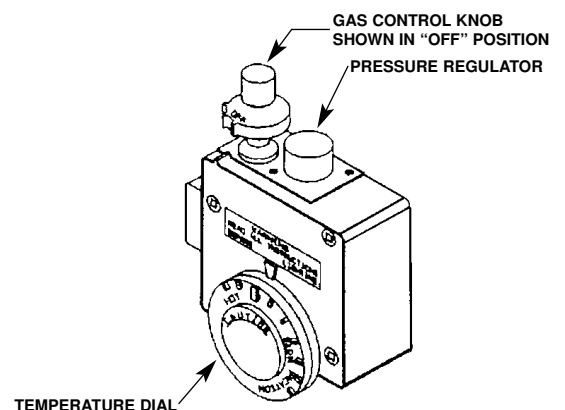

ROBERTSHAW 220R GAS CONTROL

WARNING: FAILURE TO PROPERLY SECURE THE INNER DOOR MAY POSE A SAFETY HAZARD.

12. Turn gas control knob counterclockwise ⤴ to "ON" position.
13. Set thermostat to desired setting clockwise. ⤵

To Turn Off the Gas Control

1. Set the thermostat dial to the lowest setting. Turn counterclockwise. ⤴
2. Turn gas control knob "OFF". Rotate clockwise. ⤵

WARNING

If the water heater needs to be relit;

1. Open the inner door for at least 10 minutes and force some fresh air into the combustion chamber to clear any gas from the water heater and vent system.
2. Check the vent terminal for blockage.
3. Follow the lighting instruction again.

SPECIAL NOTE ON PROPANE FUEL: L.P. GAS IS HEAVIER THAN AIR

Should there be a leak in the system, the gas will settle at FLOOR LEVEL. Basements, crawl spaces, closets and areas below ground level will serve as pockets for the accumulation of the gas.

BEFORE LIGHTING, SNIFF AT FLOOR LEVEL. IF YOU SMELL GAS, FOLLOW THESE RULES.

1. Get all people out of the building.
2. **DO NOT** light matches.
3. **DO NOT** touch electrical switches (on or off).
4. **DO NOT** use an electrical fan to remove gas from area.
5. **SHUT OFF GAS** at the L.P. tank outside of the building.
6. **IMMEDIATELY** call the L.P. Gas Company or the fire department from a neighbor's phone. Ask for instructions. Before hanging up, give your name, address and telephone number.
7. **DO NOT** go back into the building. If help is coming, wait for it outside the building.

OUT OF FUEL

When your L.P. tank runs out of fuel, turn off gas at all gas appliances. After L.P. tank is refilled, all appliances must be re-lit according to the manufacturers instructions.

WATER TEMPERATURE REGULATION

The thermostat is adjusted to its lowest temperature position when shipped from the factory. The temperature of the water can be selected by setting of the temperature dial on the top of the gas control. See Figure 4.

The "LOW" position on the thermostat is the preferred starting point for setting the temperature/control knob (approximately 120°F (50°C)).

The lowest setting will maintain the minimum water temperature if you are going away for an extended period. The burner may be extinguished if operated below this temperature.

Energy conservation is a consideration when selecting the water temperature setting.

HIGHER SETTING INCREASES THE RISK OF SCALD INJURY

In households with children or invalids and/or elderly persons, select a lower temperature setting. To reduce the risk of scalding, valves for reducing the point of discharge water temperature by mixing in branch water lines are available. Please consult a licensed plumber or plumbing authority.

EXPOSURE TO WATER

IMPORTANT

Should the water heater be subjected to flooding, fire, or other unusual condition, turn off gas at the manual gas shut-off valve and water at the inlet valve to the heater. Do not put the heater in operation until it has been thoroughly checked by a qualified gas technician.

TAMPERING

Tampering with the thermostat, gas valve or temperature pressure relief valve is DANGEROUS and voids all warranties. Only qualified personnel should service these components.

BURNER MAINTENANCE

At least every 3 months, check the burner and pilot flames. The burner flames must be a soft blue flame with no yellow tips. Yellow tips indicate a carburizing flame which can, depending on severity, deposit carbon (soot) on the combustion chamber and flue passages.

A sheet metal burner is used on natural gas models. See Figure 5.

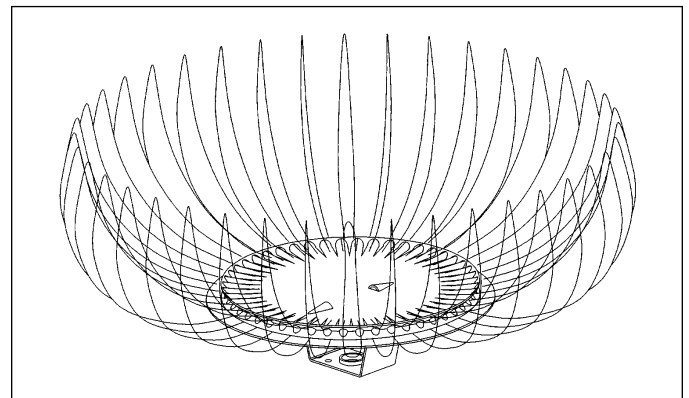

Figure 5

The sheet metal burner for Natural Gas has no external air adjustment. It is fully self-compensating and no outside adjustment is required. Observe the flame pattern. Ensure that no debris has fallen on top of the burner and no foreign objects have been introduced into the combustion chamber. Ensure that the vent terminal openings are not obstructed and the inner door to the combustion chamber is closed.

GAS CONTROL

For gas control replacement, contact your local gas utility, or a qualified serviceman. The replacement control must be an identical model to the control which has been removed.

MAINTENANCE INSTRUCTIONS - GENERAL HOUSEKEEPING

As a precaution against fire, and to maintain an adequate flow of combustion air to the heater:

- keep the appliance area clear and free from combustible material, gasoline, and other flammable vapours and liquids,
- keep the terminal openings unobstructed
- do not pile cartons, paper or combustible material on top of the heater.

TANK

Drain at least a pail of water from the drain valve once a month. Some deposit will be washed out of the tank. If larger particles, resembling a coarse sand are washed out, or if the drain becomes clogged while draining, an excess of lime deposit has settled on the tank bottom and it is time to do a major tank cleaning. Consult your local Gas Utility or a qualified serviceman.

VENTING SYSTEM INSPECTION

Every 3 months, when inspecting the burner flame, an inspection of the venting system should be made. Check these points:

1. To make certain vent terminal is securely attached and free of obstruction.
2. Inspect air pipe to make certain its components are securely fastened, sealed and are in good condition.
3. To make certain inner door on water heater is securely fastened.

CORRECT ANY DEFECTS IMMEDIATELY.

TEMPERATURE & PRESSURE RELIEF VALVE

The Temperature and Pressure Relief Valve (T&P valve) is a part of the safety equipment on the water heater. In order to keep the T&P valve functioning properly, operate the valve at least once a year by lifting the manual lever until water discharges from the overflow pipe.

CAUTION

The water flowing from the valve will be HOT.

Keep hands and feet away from the stream of water. Take care that the discharging water does not damage any flooring, carpeting or other parts of the building which may be damaged by water. See also section on T&P valve in the installation section.

CATHODIC PROTECTION

Depending on the model, one or two magnesium anodes are factory installed inside the tank to provide corrosion protection and to extend tank life. Permanent removal of the anode(s) for any purpose will void the warranty. Read the warranty attached to this water heater for a full explanation of the time period that parts and the heater are warranted.

It is advisable to inspect the condition of the anode(s) at certain intervals. A 2 year period may be a guide to begin with. The life of the anode depends on many factors and can differ greatly from one location to another.

To remove an anode, proceed as follows:

1. Turn the gas off at the inlet to the heater.
2. Turn water off at the cold water inlet valve.
3. Open a nearby hot water tap.
4. Drain approximately one pail full of water from the heater.
5. With a 1 1/16" hexagon socket wrench, loosen the anode from the fitting in the tank top.

NOTE: The anode has been factory installed using a power tool. It will be necessary for a second person to restrain the heater. A few sharp blows on the handle of the socket wrench will loosen the anode nut.

If an impact wrench (power drive) is available, this is an easy way to remove an anode.

6. Lift the anode up and inspect. There should be at least 3/8" to 1/2" of anode diameter left. The surface may be rough, full of pits and crevices, but this is normal.

If there is less than approximately 3/8" diameter left, the anode needs to be replaced.

7. Apply a good grade of pipe dope to the threads of the anode adaptor and screw securely into the tank top.
8. Open the cold water inlet valve and fill tank.
9. Check for leaks.
10. Relight burner by following lighting instructions on page 7.

Water supply conditions may vary depending on the region where this water heater is installed, and in some cases the water may have an adverse effect on the operation of the anode.

If a sulphurous, or "rotten egg" smell is noticeable in the hot water supplied by this heater, it is an indication that the water source is not compatible with the magnesium anode which is factory installed. Replace the anode to an aluminum anode or a water treatment for removal of sulphur from the water supply.

CONTROL

If the heater or the controls have been subjected to flooding, shut off the gas at the manual shut-off valve to the heater and call your gas company.

The heater operates under a fully automatic control. Once the desired water temperature has been selected, the gas control will maintain that temperature within close limits.

DO NOT TAMPER WITH THE GAS CONTROL!

CAUTION

Hydrogen gas can be produced in a hot water system served by this heater that has not been used for a long period of time (generally two weeks or more). **Hydrogen gas is extremely flammable.** To reduce the risk of injury under these conditions, it is recommended that the hot water faucet be opened for several minutes at the kitchen sink before using any electrical appliance. If hydrogen is present, there will probably be an unusual sound such as air escaping through the pipe as the water begins to flow. There should be no smoking or open flame near the faucet at the time it is open.

INSTALLATION INSTRUCTIONS FOR WATER HEATERS APPROVED FOR SPACE HEATING AND POTABLE WATER HEATING

When using this water heater in the application of a combination space and potable water heating system, be sure to follow instructions provided with the water heater and the manual shipped with the air handler.

NOTE the following warnings:

1. The piping and components connected to the water heater for the space heating applications shall be suitable for use with potable water. The system should be installed with new non-ferrous piping. Do not use pumps, valves, fittings, solder, gluing and pipe sealant that are not completely compatible with potable water piping.
2. A water heater which will be used to supply potable water must not be connected to any heating system or components previously used with a non-potable water heating appliance. Do not use: piping that has been treated; boiler seal chromates; or other chemicals.

3. Do not use this heater as a replacement for an existing boiler installation.
4. Do not introduce toxic chemicals such as those used for boiler treatment into the potable water used for space heating.
5. If the space heating water system requires water with temperatures in excess of 140°F, a mixing valve or other means must be installed in the potable hot water supply to temper the water and reduce scald hazard potential.
6. If the heater is installed with a back-flow preventer on the incoming water line or in a closed system, a diaphragm-type expansion tank must be installed in the system to prevent weeping due to expansion.
7. Proper sizing of the water heater for the given space and potable heating application is essential to ensure adequate heating capacity. The sizing and installation of such combination system must be performed by qualified personnel and be in accordance with public utility requirements and/or Codes having jurisdiction.

The sizing of the water heater should be based on the design heat loss of the structure to be heated plus the potable water requirements.

IT IS IMPORTANT THAT THE WATER HEATER USED BE OVERSIZED TO ALLOW ADEQUATE HEATING AND POTABLE WATER HEATING CAPACITY.

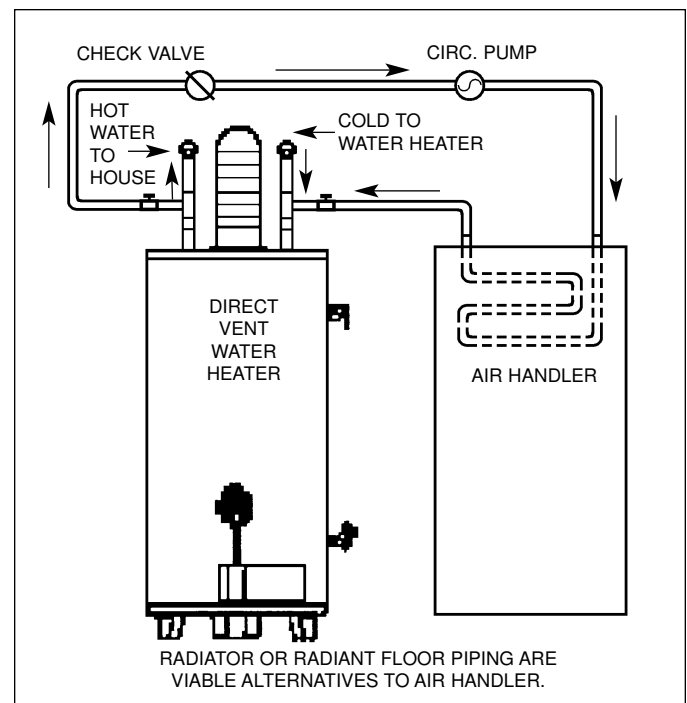

Figure 9

~ Certificate of Warranty ~

See Rating Label Serial Number prefix for Warranty Code. Reduced warranty period applies to Newfoundland.

Warranty Code:	P	R	S	T	U	V	W	Y
Standard Warranty Years:	3	5	6	7	8	9	10	12
Reduced Warranty Years:	2	3	3	5	5	5	5	7

For its GSW and John Wood water heaters and storage boosters ("Unit"), GSW Water Heating ("GSW") warrants that, upon receipt of a properly verified Warranty claim within the Warranty Period, it will, at its election, repair or replace: units which leak or parts which are defective in material or workmanship, subject to the terms and conditions set forth in this certificate. GSW will not assume any expense or liability for unauthorized returns, nor repairs made by a person who has not been authorized by GSW or one of its authorized dealers. GSW Units/parts must be replaced with GSW or John Wood products to be eligible for Warranty. This Warranty is available to the original owner of a Unit installed within the boundaries of continental United States, of Canada, or their territories. **Consumers must retain point-of-sale proof of purchase to validate warranty entitlement.** This Warranty does not cover components not manufactured by GSW, such as oil burners, which carry the warranty given by the manufacturer thereof, copy of which warranty GSW will make available, to the extent supplied by the manufacturer, without recourse to GSW.

THERE ARE NO WARRANTIES WHICH EXTEND BEYOND THE DESCRIPTION ON THE FACE HEREOF. THIS EXPRESS WARRANTY IS, WHERE PERMITTED BY LAW, IN LIEU OF AND EXCLUDES AND REPLACES ALL OTHER CONDITIONS, WARRANTIES, GUARANTEES, REPRESENTATIONS, OBLIGATIONS OR LIABILITIES OF GSW OF ANY NATURE OR KIND, EXPRESS OR IMPLIED, HOWEVER ARISING (WHETHER BY CONTRACT, CONDUCT, STATEMENT, STATUTE, NEGLIGENCE, PRINCIPLES OF MANUFACTURER'S LIABILITY, OPERATION OF LAW OR OTHERWISE) WITH RESPECT TO THE UNIT OR ITS FITNESS FOR A PARTICULAR PURPOSE, MERCHANTABILITY, INSTALLATION, OPERATION, REPAIR OR REPLACEMENT. GSW EXPRESSLY DISCLAIMS ANY AND ALL IMPLIED WARRANTIES. IN NO EVENT WILL GSW'S LIABILITIES EXCEED THE COST OF THE DEFECTIVE PART(S) OR UNIT. GSW WILL NOT PAY FOR ANY TRANSPORTATION, LABOUR, INSTALLATION, OR OTHER INCIDENTAL COSTS ASSOCIATED WITH THE REPAIR OR REPLACEMENT OF A DEFECTIVE PART OR UNIT.

This warranty and GSW's obligations shall be construed and determined in accordance with the laws of both the Province of Ontario, and of Canada in force therein. This Warranty does not affect specific legal rights of a consumer under applicable law, except to the extent that such rights may be waived or replaced, and the provisions hereof are deemed to be amended to the extent necessary. The unenforceability of any provision, in whole or in part, of this Certificate shall not affect the remaining provisions. Any and all repair and/or replacement of part(s) or Unit are the sole and exclusive remedy available against GSW.

LIABILITY OF GSW COVERED BY THIS WARRANTY IS CONDITIONAL UPON THE FOLLOWING:

1. The Unit shall be installed in accordance with all manufacturers' instructions, all applicable equipment and building codes, ordinances and regulations (hereinafter referred to as the "standards").
2. The Unit must not be installed where water damage can result from a leak, while provision(s) shall be made for directing any water escaping from the Unit, to a properly operating drainpipe. As all units of this type may eventually leak, you must protect against any potential water damage. GSW accepts no responsibility for such damage, nor any incidental or consequential loss, nor damage(s) related thereto, suffered by the owner of the Unit nor by any third party.
3. The Unit shall not be installed where it will be exposed to adverse or unusual environmental or corrosive conditions. No warranty extends, for example, and without limitation of the foregoing, to Units exposed to: salts; chemicals; exhausts; pollutants or contaminants. Further, no warranty extends to Units affected by fire, freezing or flood, "Acts of God", or any other contingency beyond the control of GSW.
4. The Unit shall be equipped with a properly operating temperature and pressure relief valve as specified by GSW and applicable standards. The Unit shall be operated at temperatures not exceeding the maximum setting of the thermostat and/or high limit control provided by GSW, and at water pressures not exceeding the pressure reading stated on the Unit.
5. The Unit must be carefully inspected, maintained, and operated in accordance with the manufacturer's instructions. No warranty extends, for example, and without limitation of the foregoing, to any Unit operated: without the tank being completely filled with water; without an operating anode; with levels of sediment or lime precipitate which cause failure; in connection to any attachment(s), energy saving device(s), or other means of heating, except as approved by GSW for the Unit; other than with potable water without any additives such as salts, chlorine or chemicals, except those added for the sole purpose of rendering the water fit for domestic use.
6. All repairs must be made by a competent and qualified person who is certified, by GSW or one of its authorized dealers, to work on the Unit, using factory approved replacement parts, and the Unit shall not be otherwise modified, altered or improperly repaired.
7. A properly documented claim shall be received by GSW or one of its authorized dealers, or point of purchase, within the following Warranty Period, except as provided otherwise below*:
 - a) for any defective part, within one (1) year; or
 - b) for any Unit that develops leaks in the inner tank due to rust, corrosion or other chemical reactions caused by the potable domestic water supplied to your home, within the period of time shown in table at the top of this page.* Residential units installed and used in a commercial application carry a warranty period of one (1) year from date of installation; and, Any repair or replacement of any part, tank, or Unit under this Warranty will not extend the Warranty Period beyond that calculated from the date of first installation of the original Unit. The date of first installation will be deemed to be the later of the date indicated by the Unit's serial number, or if supplied with the Warranty claim, the sales receipt, or installer's receipt.
8. A claim under this Warranty must include the model and serial number of the Unit, proof of date on which the Unit was first installed, and the identity of the defective part(s) for which a claim is being made and be submitted within 15 days following discovery of the defect(s), by personal delivery to a GSW authorized dealer, point of purchase, or GSW itself at:

**GSW Water Heating
A GSW Company
599 Hill Street West
Fergus, ON Canada N1M 2X1**

Should you have questions, please call our Technical Support Line at **1-888-479-8324**.
9. If requested by GSW, information relating to the purchase, transportation, operation and installation of the Unit must be supplied. The defective part(s) or Unit, with all components properly and securely packed, shall be returned transportation pre-paid, to the address designated by GSW in the written request. All claims are subject to validation by GSW.

Free Manuals Download Website

<http://myh66.com>

<http://usermanuals.us>

<http://www.somanuals.com>

<http://www.4manuals.cc>

<http://www.manual-lib.com>

<http://www.404manual.com>

<http://www.luxmanual.com>

<http://aubethermostatmanual.com>

Golf course search by state

<http://golfingnear.com>

Email search by domain

<http://emailbydomain.com>

Auto manuals search

<http://auto.somanuals.com>

TV manuals search

<http://tv.somanuals.com>