

Grizzly **Industrial, Inc.**®

MODEL G7945/46 RADIAL DRILL PRESS OWNER'S MANUAL

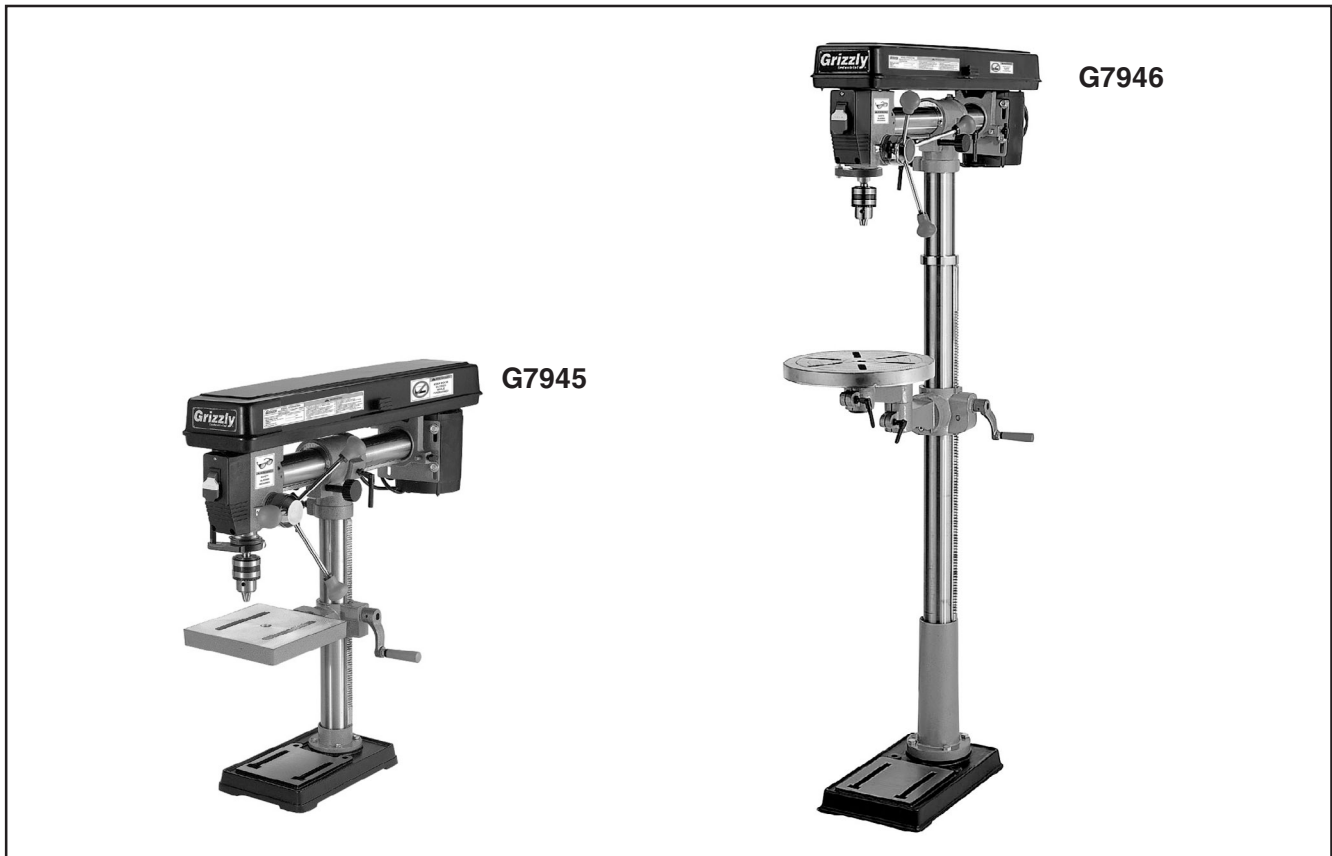

COPYRIGHT © JANUARY, 2001 BY GRIZZLY INDUSTRIAL, INC. REVISED AUGUST, 2009 (TR)
**WARNING: NO PORTION OF THIS MANUAL MAY BE REPRODUCED IN ANY SHAPE
OR FORM WITHOUT THE WRITTEN APPROVAL OF GRIZZLY INDUSTRIAL, INC.**
(FOR MODELS MANUFACTURED SINCE 3/07) #DS3298 PRINTED IN CHINA

 **WARNING!**

This manual provides critical safety instructions on the proper setup, operation, maintenance and service of this machine/equipment.

Failure to read, understand and follow the instructions given in this manual may result in serious personal injury, including amputation, electrocution or death.

The owner of this machine/equipment is solely responsible for its safe use. This responsibility includes but is not limited to proper installation in a safe environment, personnel training and usage authorization, proper inspection and maintenance, manual availability and comprehension, application of safety devices, blade/cutter integrity, and the usage of personal protective equipment.

The manufacturer will not be held liable for injury or property damage from negligence, improper training, machine modifications or misuse.

 **WARNING!**

Some dust created by power sanding, sawing, grinding, drilling, and other construction activities contains chemicals known to the State of California to cause cancer, birth defects or other reproductive harm. Some examples of these chemicals are:

- **Lead from lead-based paints.**
- **Crystalline silica from bricks, cement and other masonry products.**
- **Arsenic and chromium from chemically-treated lumber.**

Your risk from these exposures varies, depending on how often you do this type of work. To reduce your exposure to these chemicals: Work in a well ventilated area, and work with approved safety equipment, such as those dust masks that are specially designed to filter out microscopic particles.

Table of Contents

INTRODUCTION	2	SECTION 5: ACCESSORIES	29
Manual Accuracy	2	SECTION 6: MAINTENANCE.....	31
Contact Info.....	2	General	31
Identification.....	3	Cleaning.....	31
G7945 Machine Data Sheet	4	Unpainted Cast Iron.....	31
G7946 Machine Data Sheet	6	Lubrication	31
SECTION 1: SAFETY	8	V-Belts	31
Safety Instructions for Machinery	8	SECTION 7: SERVICE	32
Additional Safety for Drill Presses	10	About Service.....	32
SECTION 2: CIRCUIT REQUIREMENTS	11	Troubleshooting	32
110V Operation.....	11	Depth Stop Calibration.....	34
SECTION 3: SET UP	12	Feed Shaft Spring Tension	34
Items Needed for Set Up	12	Electrical Components.....	35
Unpacking	12	G7945/G7946 Wiring Diagram	36
Inventory	13	G7945/G7946 Main Parts Breakdown.....	37
Hardware Recognition Chart	14	G7945 Column Breakdown.....	39
Clean Up.....	15	G7946 Column Breakdown.....	40
Site Considerations.....	15	Safety Label Placement and Parts List.....	42
Column and Base	16	WARRANTY AND RETURNS	45
Table Bracket.....	16		
Headstock	17		
Downfeed Handles	18		
Drill Chuck and Arbor.....	18		
Test Run	19		
Mounting	19		
Recommended Adjustments.....	21		
SECTION 4: OPERATIONS	22		
Switch/Safety Key	22		
Installing/Removing Drill Bits	22		
Choosing Speeds.....	23		
Changing Speeds	24		
Drilling	25		
Depth Stop	26		
Table Adjustments	26		
Head Adjustments.....	28		

INTRODUCTION

Manual Accuracy

We are proud to offer this manual with your new machine! We've made every effort to be exact with the instructions, specifications, drawings, and photographs of the machine we used when writing this manual. However, sometimes errors do happen and we apologize for them.

Also, owing to our policy of continuous improvement, **your machine may not exactly match the manual**. If you find this to be the case, and the difference between the manual and machine leaves you in doubt, check our website for the latest manual update or call technical support for help.

Before calling, find the manufacture date of your machine by looking at the date stamped into the machine ID label (see below). This will help us determine if the manual version you received matches the manufacture date of your machine.

		MODEL GXXXX	
		MACHINE NAME	
SPECIFICATIONS		⚠ WARNING!	
Motor:		Manufacture Date of Your Machine When using this machine: operation. is and respirator. sted/setup and suit before starting.	
Specification:			
Specification:			
Specification:			
Weight:			
	Date	4. Make sure the motor has stopped and disconnect power before adjustments, maintenance, or service.	
	Serial Number	5. DO NOT expose to rain or dampness.	
Manufactured for Grizzly in Taiwan		6. DO NOT modify this machine in any way.	
		7. DO NOT remove safety guards.	
		8. Never leave machine running unattended.	
		9. DO NOT operate under the influence of drugs or alcohol.	
		10. Maintain machine carefully to prevent accidents.	

For your convenience, we post all available manuals and manual updates for free on our website at www.grizzly.com. Any updates to your model of machine will be reflected in these documents as soon as they are complete.

Contact Info

We stand behind our machines. If you have any service questions, parts requests or general questions about the machine, please call or write us at the location listed below.

Grizzly Industrial, Inc.
1203 Lycoming Mall Circle
Muncy, PA 17756
Phone: (570) 546-9663
Fax: (800) 438-5901
E-Mail: techsupport@grizzly.com

If you have any comments regarding this manual, please write to us at the address below:

Grizzly Industrial, Inc.
% Technical Documentation Manager
P.O. Box 2069
Bellingham, WA 98227-2069
Email: manuals@grizzly.com



Identification

Refer to the list below and see **Figures 1 & 2** to become familiar with the drill press controls.

1. **Power Switch:** Turns motor **ON/OFF**.
2. **Belt Tension Lock Knobs:** Locks motor in place to maintain belt tension.
3. **Horizontal Adjustment Lever:** Moves the headstock along the horizontal rack.
4. **Clamp Bolts:** Lock table rotation, horizontal movement of drill press, and lock drill press rotation on column.
5. **Crank Handle:** Raises/lowers table.
6. **Downfeed Handles:** Move the chuck up or down.
7. **Depth Stop:** Limits quill travel to a pre-set drilling depth.
8. **Lash Screw:** Removes quill lash.
9. **Torsion Spring:** Returns quill into headstock.
10. **Lock Pin:** Locks headstock in the vertical position. When unlocked, headstock can be tilted.
11. **Headstock Angle Tilt Scale:** Displays current headstock-tilt angle.

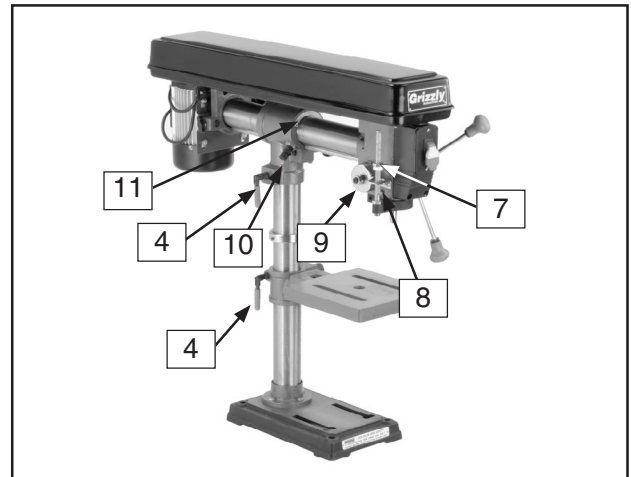

Figure 2. Left-side controls.

Refer to the list below to become familiar with the drill press terms and definitions.

Headstock: The cast iron upper portion of the drill press, which houses the quill and work light, and supports the motor and belt housing.

Arbor: A tapered shaft that connects the chuck to the spindle.

Quill: Houses the spindle and bearings.

Spindle: The hollow shaft that accepts the arbor.

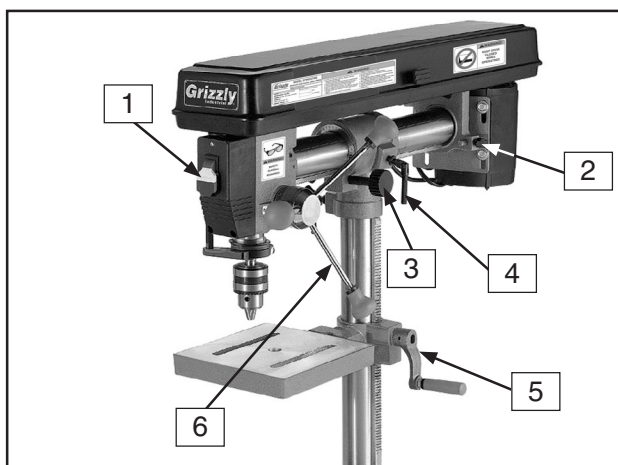

Figure 1. Right-side controls.

Model G7945/G7946 (Mfg. Since 3/07)





MACHINE DATA SHEET

Customer Service #: (570) 546-9663 · To Order Call: (800) 523-4777 · Fax #: (800) 438-5901

MODEL G7945 5 SPEED BENCH-TOP RADIAL DRILL PRESS

Product Dimensions:

Weight..... 88 lbs.
 Length/Width/Height.....33-1/2 x 11-1/2 x 31-1/2 in.
 Foot Print (Length/Width)..... 13-1/2 x 8-1/2 in.

Shipping Dimensions:

Type..... Cardboard
 Content..... Machine
 Weight..... 97 lbs.
 Length/Width/Height..... 36 x 18 x 13 in.

Electrical:

Switch..... Toggle On/Off with Safety Lock Tab
 Switch Voltage..... 110V
 Cord Length..... 7 ft.
 Cord Gauge..... 16 gauge
 Minimum Circuit Size..... 10 amp
 Plug Included..... Yes

Motors:

Main

Type..... TEFC Capacitor Start Induction
 Horsepower..... 1/2 HP
 Voltage..... 110V
 Prewired..... 110V
 Phase..... Single
 Amps..... 5A
 Speed..... 1720 RPM
 Cycle..... 60 Hz
 Number Of Speeds..... 1
 Power Transfer V-Belt Drive
 Bearings..... Shielded and Lubricated

Main Specifications:

Construction

Table Construction..... Precision Ground Cast Iron
 Spindle Housing Construction..... Cast Iron
 Column Construction..... Cylindrical Ground Steel
 Head Construction..... Cast Iron
 Base Construction..... Cast Iron
 Paint..... Epoxy

Head Information

Head Tilt..... 90 deg.
 Maximum Movement Of Head Casting..... 12-1/2 in.
 Head Swivel..... 360 deg.



Other Related Information

Base Length.....	13-1/2 in.
Base Width.....	8-1/2 in.
Quill Diameter.....	0.575 in.
Depth Stop Type.....	Threaded Rod with Positive Stop
Column Diameter.....	2.360 in.

Spindle Information

Spindle Taper.....	JT#33
Spindle Travel.....	3-1/4 in.
Dist From Spindle To Column.....	5-1/2 - 17 in.
Dist From Spindle To Table.....	14-1/2 in.
Dist From Spindle To Base.....	19 in.

Table Information

Table Length.....	9 in.
Table Width.....	8-5/8 in.
Table Thickness.....	1-1/4 in.
Floor To Table Height.....	6-1/2 - 16 in.
Vertical Table Movement.....	Crank Handle Operate
Table Swing.....	360 deg.
Table Tilt.....	Left and Right 90 deg.
Table Swivel Around Center.....	360 deg.
Table Swivel Around Column.....	360 deg.
Maximum Movement Of Work Table.....	9-3/4 in.
No. Of T Slots.....	2
T Slot Width.....	5/8 in.
T Slot Length.....	6 in.

Operation Information

Swing.....	34 in.
Drilling Capacity.....	1/2 in. in Steel
No. Of Spindle Speeds.....	5
Range Of Spindle Speeds.....	550, 880, 1520, 2490, 3470 RPM
Drill Chuck Type.....	JT33 Key Chuck
Drill Chuck Size.....	5/8 in.

Other Specifications:

Country Of Origin	China
Warranty	1 Year
Serial Number Location	Data Label on Head
Awards	Popular Woodworking Editor's Choice Tool Buying Guide
Assembly Time	30 minutes

Features:

- Threaded Depth Stop
- Crank Handle Operated Rack and Pinion Vertical Table Movement
- Table Has Lock Levers
- Table and Base are Cast Iron
- Radial Design Allows Angle Drilling
- 5 Speeds
- 1/2HP Motor
- Cushioned Grip Quill Handles
- 1/8" - 5/8" Chuck





MACHINE DATA SHEET

Customer Service #: (570) 546-9663 · To Order Call: (800) 523-4777 · Fax #: (800) 438-5901

MODEL G7946 5 SPEED FLOOR RADIAL DRILL PRESS

Product Dimensions:

Weight..... 138 lbs.
 Length/Width/Height..... 32 x 14 x 64-1/2 in.
 Foot Print (Length/Width)..... 18 x 11 in.

Shipping Dimensions:

Type..... Cardboard
 Content..... Machine
 Weight..... 147 lbs.
 Length/Width/Height..... 56 x 20 x 10 in.

Electrical:

Switch..... Paddle On/Off with Safety Lock Tab
 Switch Voltage..... 110V
 Cord Length..... 7 ft.
 Cord Gauge..... 16 gauge
 Minimum Circuit Size..... 10 amp
 Plug Included..... Yes

Motors:

Main

Type..... TEFC Capacitor Start Induction
 Horsepower..... 1/2 HP
 Voltage..... 110V
 Prewired..... 110V
 Phase..... Single
 Amps..... 5A
 Speed..... 1720 RPM
 Cycle..... 60 Hz
 Number Of Speeds..... 1
 Power Transfer V-Belt Drive
 Bearings..... Shielded and Lubricated

Main Specifications:

Construction

Table Construction..... Precision Ground Cast Iron
 Spindle Housing Construction..... Cast Iron
 Column Construction..... Cylindrical Ground Steel
 Head Construction..... Cast Iron
 Base Construction..... Cast Iron
 Paint..... Epoxy

Head Information

Head Tilt..... 90 deg.
 Maximum Movement Of Head Casting..... 12-1/2 in.
 Head Swivel..... 360 deg.



Other Related Information

Base Length.....	17-1/2 in.
Base Width.....	10-1/2 in.
Quill Diameter.....	0.575 in.
Depth Stop Type.....	Hub
Column Diameter.....	2.790 in.
Mobile Base.....	G8683

Spindle Information

Spindle Taper.....	JT#33
Spindle Travel.....	3-1/4 in.
Dist From Spindle To Column.....	5-1/2 - 17 in.
Dist From Spindle To Table.....	30-1/2 in.
Dist From Spindle To Base.....	51 in.

Table Information

Table Diameter.....	12-3/16 in.
Table Thickness.....	1 in.
Floor To Table Height.....	22-1/2 - 48 in.
Vertical Table Movement.....	Crank Handle Operate
Table Swing.....	360 deg.
Table Tilt.....	Left and Right 90 deg.
Table Swivel Around Center.....	360 deg.
Table Swivel Around Column.....	360 deg.
Maximum Movement Of Work Table.....	24-1/2 in.
No. Of T Slots.....	6
T Slot Width.....	5/8 in.
T Slot Length.....	3-1/4 in.

Operation Information

Swing.....	33-1/2 in.
Drilling Capacity.....	1/2 in. in Steel
No. Of Spindle Speeds.....	5
Range Of Spindle Speeds.....	550, 880, 1520, 2490, 3470 RPM
Drill Chuck Type.....	JT33 Key Chuck
Drill Chuck Size.....	5/8 in.

Other Specifications:

Country Of Origin	China
Warranty	1 Year
Serial Number Location	Data Label on Head
Awards	Popular Woodworking Editor's Choice Tool Buying Guide
Assembly Time	30 minutes

Features:

- Threaded Depth Stop
- Table Has Lock Levers
- Cushioned Grip Quill Handles
- Crank Handle Operated Rack and Pinion Vertical Table Movement
- Table and Base are Cast Iron
- 5 Speeds
- 1/2HP Motor
- Radial Design Allows Angle Drilling
- 1/8" -5/8" Chuck



SECTION 1: SAFETY

WARNING

For Your Own Safety, Read Instruction Manual Before Operating this Machine

The purpose of safety symbols is to attract your attention to possible hazardous conditions. This manual uses a series of symbols and signal words intended to convey the level of importance of the safety messages. The progression of symbols is described below. Remember that safety messages by themselves do not eliminate danger and are not a substitute for proper accident prevention measures.



DANGER Indicates an imminently hazardous situation which, if not avoided, WILL result in death or serious injury.



WARNING Indicates a potentially hazardous situation which, if not avoided, COULD result in death or serious injury.



CAUTION Indicates a potentially hazardous situation which, if not avoided, MAY result in minor or moderate injury. It may also be used to alert against unsafe practices.

NOTICE

This symbol is used to alert the user to useful information about proper operation of the machine.

WARNING

Safety Instructions for Machinery

- 1. READ ENTIRE MANUAL BEFORE STARTING.** Operating machine before reading the manual greatly increases the risk of injury.
- 2. ALWAYS USE ANSI APPROVED SAFETY GLASSES WHEN OPERATING MACHINERY.** Everyday eyeglasses only have impact resistant lenses—they are NOT safety glasses.
- 3. ALWAYS WEAR A NIOSH APPROVED RESPIRATOR WHEN OPERATING MACHINERY THAT PRODUCES DUST.** Most types of dust (wood, metal, etc.) can cause severe respiratory illnesses.
- 4. ALWAYS USE HEARING PROTECTION WHEN OPERATING MACHINERY.** Machinery noise can cause permanent hearing loss.
- 5. WEAR PROPER APPAREL. DO NOT** wear loose clothing, gloves, neckties, rings, or jewelry that can catch in moving parts. Wear protective hair covering to contain long hair and wear non-slip footwear.
- 6. NEVER OPERATE MACHINERY WHEN TIRED OR UNDER THE INFLUENCE OF DRUGS OR ALCOHOL.** Be mentally alert at all times when running machinery.



WARNING

Safety Instructions for Machinery

7. **ONLY ALLOW TRAINED AND PROPERLY SUPERVISED PERSONNEL TO OPERATE MACHINERY.** Make sure operation instructions are safe and clearly understood.
8. **KEEP CHILDREN/VISITORS AWAY.** Keep all children and visitors away from machinery. When machine is not in use, disconnect it from power, lock it out, or disable the switch to make it difficult for unauthorized people to start the machine.
9. **UNATTENDED OPERATION.** Leaving machine unattended while its running greatly increases the risk of an accident or property damage. Turn machine **OFF** and allow all moving parts to come to a complete stop before walking away.
10. **DO NOT USE IN DANGEROUS ENVIRONMENTS.** DO NOT use machinery in damp, wet locations, or where any flammable or noxious fumes may exist.
11. **KEEP WORK AREA CLEAN AND WELL LIGHTED.** Clutter and dark shadows may cause accidents.
12. **USE A GROUNDED POWER SUPPLY RATED FOR THE MACHINE AMPERAGE.** Grounded cords minimize shock hazards. Operating machine on an incorrect size of circuit increases risk of fire.
13. **ALWAYS DISCONNECT FROM POWER SOURCE BEFORE SERVICING MACHINERY.** Make sure switch is in OFF position before reconnecting.
14. **MAINTAIN MACHINERY WITH CARE.** Keep blades sharp and clean for best and safest performance. Follow instructions for lubricating and changing accessories.
15. **MAKE SURE GUARDS ARE IN PLACE AND WORK CORRECTLY BEFORE USING MACHINERY.**
16. **REMOVE CHUCK KEYS OR ADJUSTING TOOLS.** Make a habit of never leaving chuck keys or other adjustment tools in/on the machine—especially near spindles!
17. **DAMAGED MACHINERY.** Check for binding or misaligned parts, broken parts, loose bolts, other conditions that may impair machine operation. Always repair or replace damaged parts before operation.
18. **DO NOT FORCE MACHINERY.** Work at the speed for which the machine or accessory was designed.
19. **SECURE WORKPIECE.** Use clamps or a vise to hold the workpiece when practical. A secured workpiece protects your hands and frees both hands to operate the machine.
20. **DO NOT OVERREACH.** Maintain stability and balance at all times when operating machine.
21. **MANY MACHINES CAN EJECT WORKPIECES TOWARD OPERATOR.** Know and avoid conditions that cause the workpiece to "kickback."
22. **STABLE MACHINE.** Machines that move during operations greatly increase the risk of injury and loss of control. Verify machines are stable/secure and mobile bases (if used) are locked before starting.
23. **CERTAIN DUST MAY BE HAZARDOUS** to the respiratory systems of people and animals, especially fine dust. Be aware of the type of dust you are exposed to and always wear a respirator designed to filter that type of dust.
24. **EXPERIENCING DIFFICULTIES.** If at any time you are experiencing difficulties performing the intended operation, stop using the machine! Contact our Technical Support Department at (570) 546-9663.



WARNING

Additional Safety for Drill Presses

- 1. EYE/FACE/HAND PROTECTION.** A face shield used with safety glasses is recommended. Always keep hands and fingers away from the drill bit. Never hold a workpiece by hand while drilling! **DO NOT** wear gloves when operating the drill.
- 2. SECURING BIT.** Properly tighten and securely lock the drill bit in the chuck.
- 3. CORRECT BIT.** Use only round, hex, or triangular shank drill bits.
- 4. ADJUSTING KEYS AND WRENCHES.** Remove all adjusting keys and wrenches before turning the machine **ON**.
- 5. DRILLING SHEET METAL.** Never drill sheet metal unless it is securely clamped to the table.
- 6. SURFACE/WORKPIECE PREPARATION.** Never turn the drill press **ON** before clearing the table of all objects (tools, scrap wood, etc.) **DO NOT** drill material that does not have a flat surface, unless a suitable support is used.
- 7. DAMAGED TOOLS.** Never use tools in poor condition. Dull or damaged cutting tools are hard to control and may cause serious injury.
- 8. DRILL OPERATION.** Never start the drill press with the drill bit pressed against the workpiece. Feed the drill bit evenly into the workpiece. Regularly back the bit out of deep holes to clear chips.
- 9. OPERATING SPEED.** Always operate your drill press at speeds that are appropriate for the drill bit size and the material that you are drilling.
- 10. MAINTENANCE/SPEED CHANGES.** Never do maintenance or change speeds with the machine plugged in.
- 11. MOUNTING WORKPIECES.** Use clamps or vises to secure workpiece before drilling. Position work so you avoid drilling into the table.
- 12. TABLE LOCK.** Make sure the table lock is tightened before starting the drill press.
- 13. EXPERIENCING DIFFICULTIES.** If at any time you are experiencing difficulties performing the intended operation, stop using the machine! Contact our Service Department at (570) 546-9663.

WARNING

Like all machines there is danger associated with this machine. Accidents are frequently caused by lack of familiarity or failure to pay attention. Use this machine with respect and caution to lessen the possibility of operator injury. If normal safety precautions are overlooked or ignored, serious personal injury may occur.

CAUTION

No list of safety guidelines can be complete. Every shop environment is different. Always consider safety first, as it applies to your individual working conditions. Use this and other machinery with caution and respect. Failure to do so could result in serious personal injury, damage to equipment, or poor work results.



SECTION 2: CIRCUIT REQUIREMENTS

110V Operation

!WARNING

Serious personal injury could occur if you connect the machine to power before completing the setup process. **DO NOT** connect the machine to the power until instructed later in this manual.



!WARNING

Electrocution or fire could result if machine is not grounded and installed in compliance with electrical codes. Compliance **MUST** be verified by a qualified electrician!

Full Load Amperage Draw

The Model G7945/G7946 draws the following amps under maximum load:

Amp Draw.....5 Amps

Power Supply Circuit Requirements

The power supply circuit for your machine **MUST** be grounded and rated for the amperage given below. Never replace a circuit breaker on an existing circuit with one of higher amperage without consulting a qualified electrician to ensure compliance with wiring codes. **If you are unsure about the wiring codes in your area or you plan to connect your machine to a shared circuit, consult a qualified electrician.**

Power Source 110V, Single-Phase
Minimum Circuit Size..... 15 Amps

Power Connection Device

This machine comes with a plug, similar to **Figure 3**, to connect the machine to power.

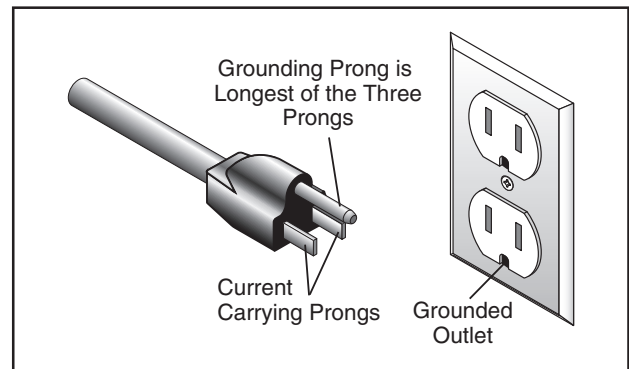
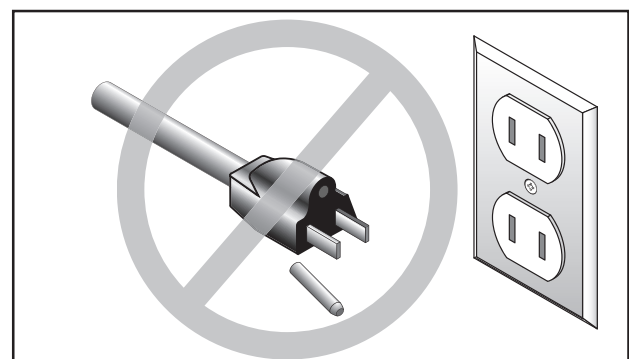

Figure 3. Typical 5-15 plug and receptacle.



!CAUTION

This machine **MUST** have a ground prong in the plug to help ensure that it is grounded. **DO NOT** remove ground prong from plug to fit into a two-pronged outlet! If the plug will not fit the outlet, have the proper outlet installed by a qualified electrician.

Extension Cords

We do not recommend using extension cords, but if you find it absolutely necessary:

- Use at least a 14 gauge cord that does not exceed 50 feet in length!
- The extension cord must have a ground wire and plug pin.
- A qualified electrician **MUST** size cords over 50 feet long to prevent motor damage.



SECTION 3: SET UP

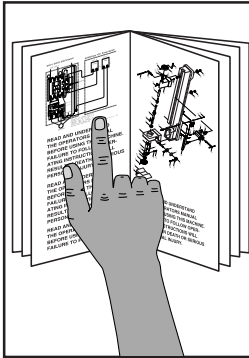

!WARNING

This machine presents serious injury hazards to untrained users. Read through this entire manual to become familiar with the controls and operations before starting the machine!

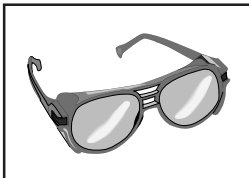

!WARNING

Wear safety glasses during the entire set up process!

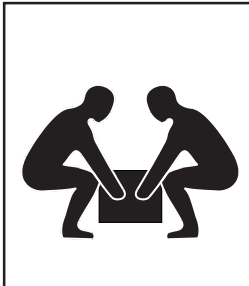

!WARNING

The Model G7945/G7946 is a heavy machine. DO NOT over-exert yourself while unpacking or moving your machine—get assistance.

Items Needed for Set Up

Some of the following items may be needed to complete the set up process, but are not included with your machine:

Description	Qty
• Wrench 16mm	1
• Wrench 3/4"	1
• People for Lifting Help	1
• Rubber Mallet	1
• 1/2" Mounting Hardware (Page 19).....	Varies
• Bottle of Mineral Spirits	1

Unpacking

The Model G7945/G7946 was carefully packed when it left our warehouse. If you discover the machine is damaged after you have signed for delivery, *please immediately call Customer Service at (570) 546-9663 for advice.*

Save the containers and all packing materials for possible inspection by the carrier or its agent. *Otherwise, filing a freight claim can be difficult.*

When you are completely satisfied with the condition of your shipment, you should inventory the contents.



Inventory

If any nonproprietary parts are missing (e.g. a nut or a washer), we would be glad to replace them, but for the sake of expediency, you can get replacements at a hardware store.

Use **Figures 4 & 5** and the inventory list below to inventory your drill press parts:

Description	Qty
1. Headstock	1
2. Base	1
3. Wrench	1
4. Hex Bolt and Wingnut Set	1
5. Column	1
6. Key	1
7. Chuck	3
8. Clamp Bolts (G7945)	3
Clamp Bolts (G7946)	5
9. Handle	1
10. Handle Crank	1
11. Downfeed Handles	3
12. Table	1
13. Lock Shoe	1
14. Table Support Arm (G7946)	1
15. Column Support Arm (G7946)	1
16. Hardware Bag (Not Shown)	1
—Hex Bolts M8-1.25 x 20 (G7945)	4
—Hex Bolts M10-1.5 x 40 (G7946)	4
—Hex Wrench 3mm	1
—Hex Wrench 4mm	1

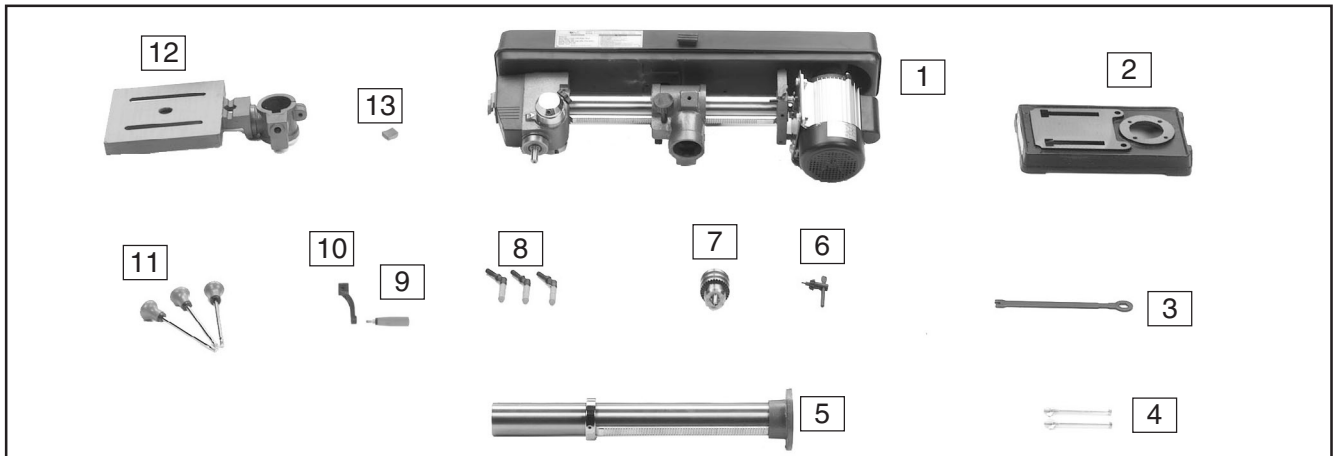

Figure 4. G7945 layout.

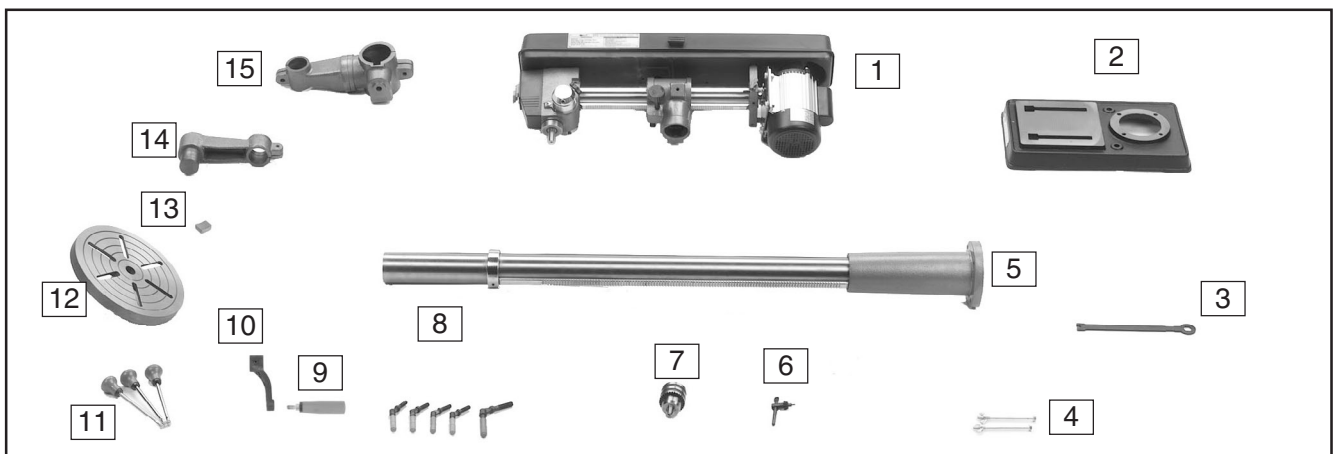

Figure 5. G7946 layout.



Hardware Recognition Chart

USE THIS CHART TO MATCH UP HARDWARE DURING THE ASSEMBLY PROCESS.

MEASURE BOLT DIAMETER BY PLACING INSIDE CIRCLE

- 5/16"
- 3/8"
- 7/16"
- 1/2"

- 4mm
- 6mm
- 8mm
- 10mm
- 12mm
- 16mm

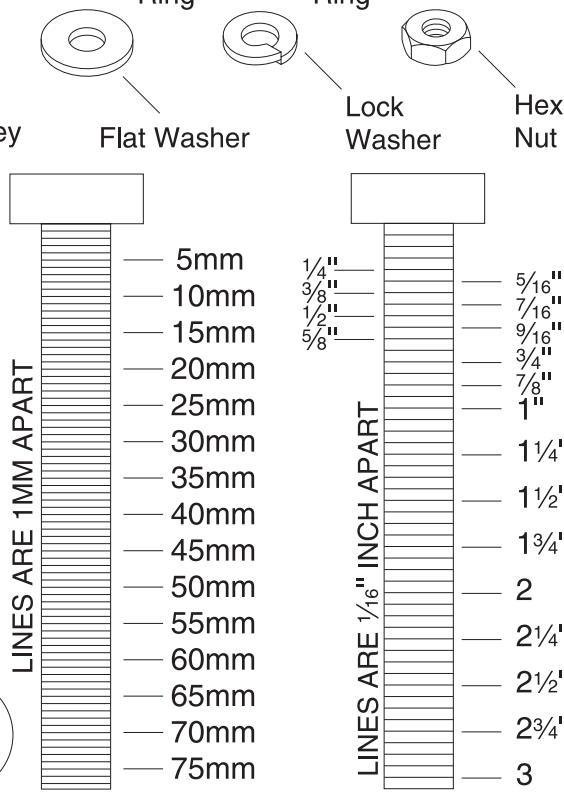
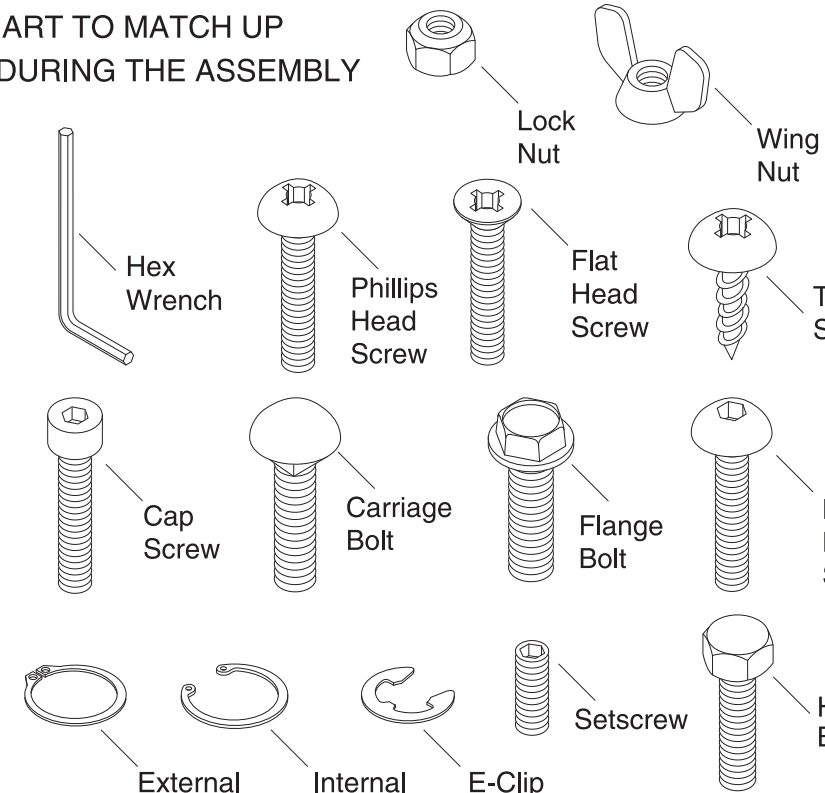

WASHERS ARE MEASURED BY THE INSIDE DIAMETER

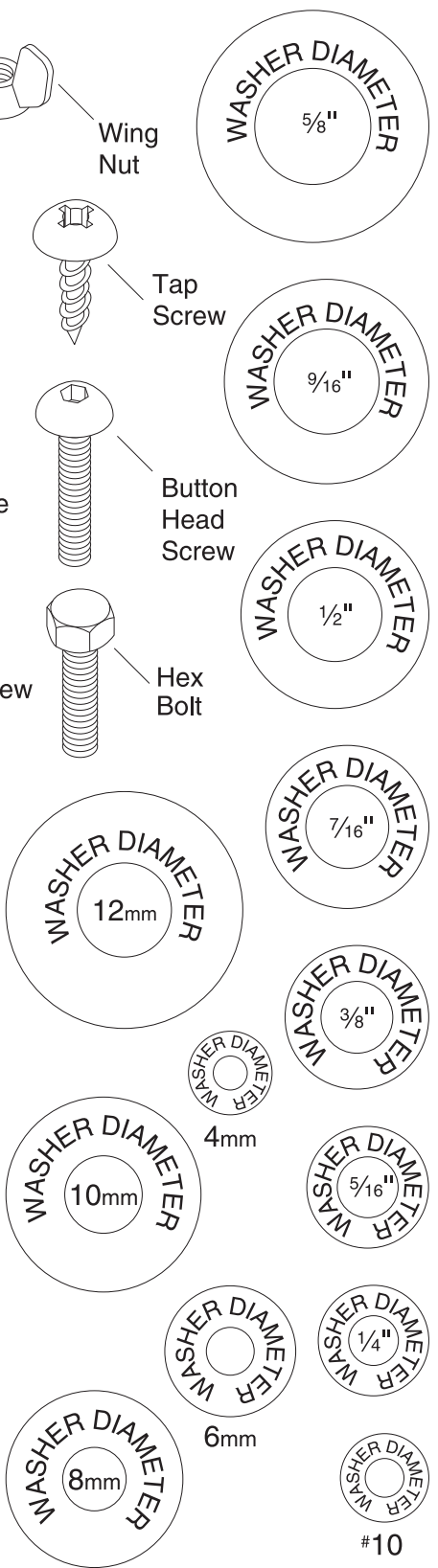

Clean Up

The unpainted surfaces are coated with a waxy oil to protect them from corrosion during shipment. Remove this protective coating with a solvent cleaner or citrus-based degreaser such as Grizzly's G7895 Degreaser. To clean thoroughly, some parts may need to be removed. **For optimum performance from your machine, make sure you clean all moving parts or sliding contact surfaces that are coated.** Avoid chlorine-based solvents, such as acetone or brake parts cleaner, as they may damage painted surfaces should they come in contact. Always follow the manufacturer's instructions when using any type of cleaning product.

	<p>⚠ WARNING Gasoline and petroleum products have low flash points and could cause an explosion or fire if used to clean machinery. DO NOT use gasoline or petroleum products to clean the machinery.</p>
--	---

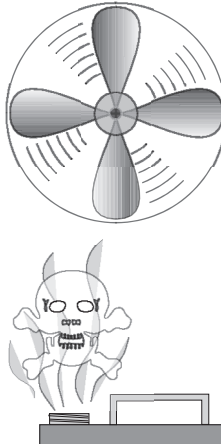
	<p>⚠ CAUTION Many of the solvents commonly used to clean machinery can be toxic when inhaled or ingested. Lack of ventilation while using these solvents could cause serious personal health risks or fire. Take precautions from this hazard by only using cleaning solvents in a well ventilated area.</p>
---	---

Site Considerations

Floor Load

Refer to the **Machine Data Sheet** for weight and footprint specifications for your machine. Some residential floors may require additional reinforcement to support both the machine and operator. Some workbenches may require additional reinforcement to support both the machine and the workpiece.

Working Clearances

Consider existing and anticipated needs, size of material to be processed through each machine, space for auxiliary stands, work tables or other machinery, and the great range of movement in the Model G7946/G7946 when establishing a location for your machine. See **Figure 6** for the minimum working clearances of the Model G7945/G7946.

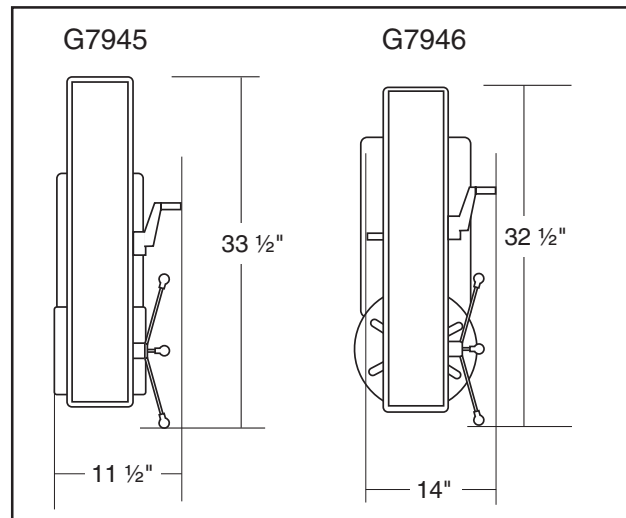

Figure 6. Working clearances.

	<p>⚠ CAUTION Unsupervised children and visitors inside your shop could cause serious personal injury to themselves. Lock all entrances to the shop when you are away and DO NOT allow unsupervised children or visitors in your shop at any time!</p>
--	---



Column and Base

Components and Hardware Needed:	Qty
Base	1
Column	1
Hex Bolts M10-1.5 x 40 (G7946).....	4
Hex Bolts M8-1.25 x 20 (G7945)	4

The column must be secured on the base to properly assemble your drill press.

To secure the column to the base:

1. Place the column on the base and align the mounting holes.
2. Secure the column to the base with the four hex bolts, as shown in **Figure 7**.



Figure 7. Column secured to base.

Table Bracket

Components and Hardware Needed:	Qty
Table	1
Crank Handle	1
Handle	1
Clamp Bolts (G7945)	1
Clamp Bolts (G7946)	3
Column	1
Column Support Arm (G7946).....	1
Table Support Arm (G7946)	1

The table bracket must be installed as described to properly assemble your drill press. The Model G7945 comes with a one piece square table and bracket. The Model G7946 comes with a round table and two-piece hinged table bracket.

To install the table bracket:

1. Check to make sure the pinion gear is fully inserted into the hole on the side of the table bracket shown in **Figure 8**.

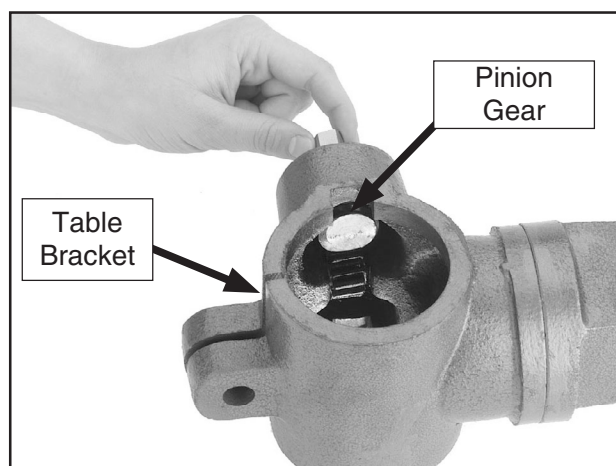

Figure 8. Pinion gear position.

2. Slide the crank handle over the pinion gear shaft and align the set screw in the crank handle with the flat portion of the shaft. Secure with a 3mm hex wrench. See **Figure 9**.
3. Thread the handle into the crank handle.
4. Remove the column ring (**Figure 10**) by loosening the set screw and remove the rack (**Figure 9**). The end of the rack that has teeth extending closest to the edge must be positioned down.



5. Insert the rack into the table bracket pocket so the gear teeth mesh and the rack is positioned as shown in **Figure 9**.

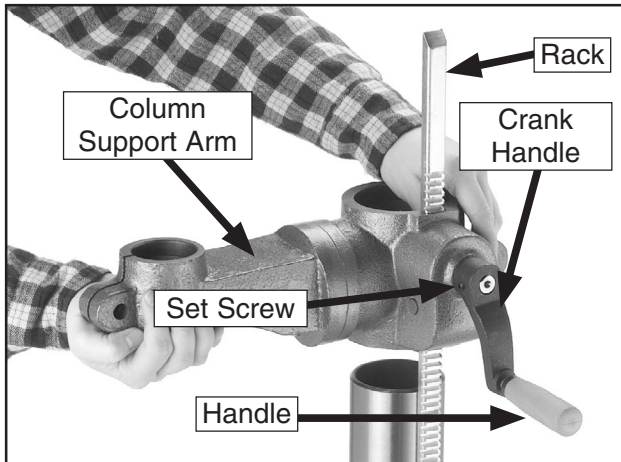

Figure 9. Rack orientation (G7946 shown).

6. Slide the table bracket and rack over the column. Let them slide down the column until the bottom of the rack contacts the shoulder of the column support.
7. Slide the column ring over the column with the beveled edge facing down (**Figure 10**), fit the beveled edge of the column ring over the rack, and tighten the set screw. **Note:** Do not over-tighten the set screw or you may split the column ring. Also make sure the rack is seated firmly in the lower ring.

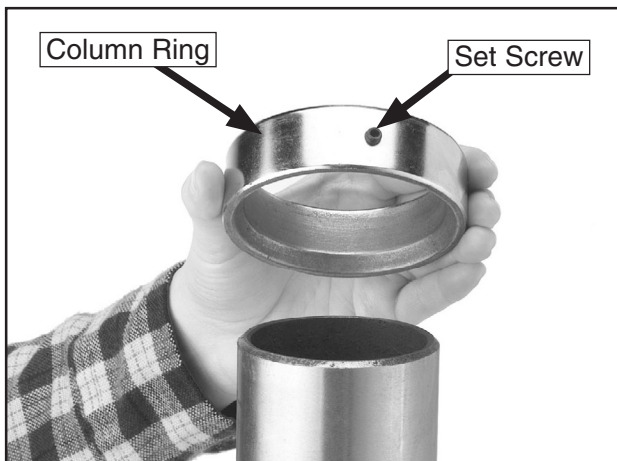

Figure 10. Inside bevel in the correct position.

8. Thread a clamp bolt into the non-threaded side on the back of the table bracket about three turns, for now.

9. Install the table support arm (G7946) onto the column support arm, then install the table.
10. Thread a clamp bolt into the non-threaded side on the table support arm and column support arm about three turns for now.

Headstock

Components and Hardware Needed:	Qty
Headstock.....	3
Lock Shoe	1
Clamp Bolts	2

To install the column:

1. Insert the included lock shoe into the recessed pocket on the inside of the headstock opening as shown in **Figure 11**.

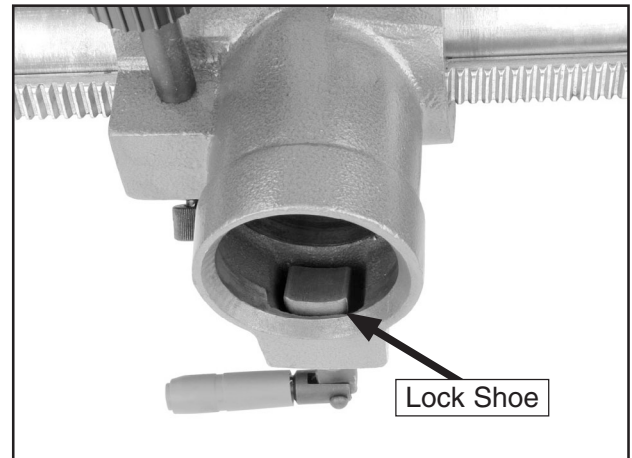
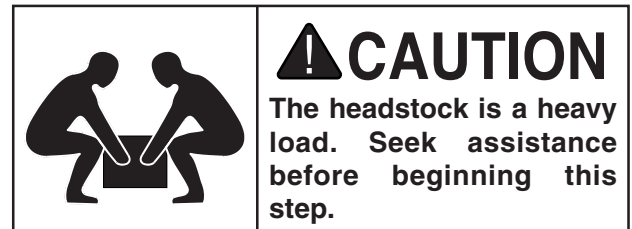

Figure 11. Lock shoe installed.



2. With the help of an assistant, lift the headstock over the top end of the column. When the underside of the headstock is lined up with the column, slide the headstock onto the column until it stops (approximately 2").



An alternate method is to lay the headstock and column on the floor, slide them together, tilt the assembly up, and position the drill press on its base in the upright position.

3. Screw two clamp bolts into each side of the horizontal column bracket (**Figure 12**).

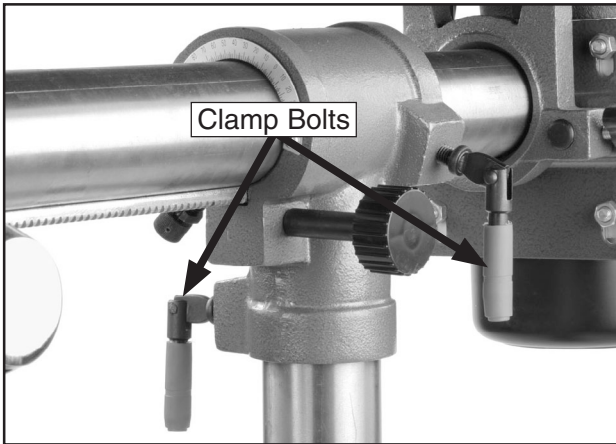

Figure 12. Clamp bolts.

Downfeed Handles

Components and Hardware Needed:	Qty
Downfeed Handles	3

The downfeed handles must be installed to properly operate the drill press.

To install the downfeed handles:

1. Tightly thread the handles into the collar as shown in **Figure 13**.

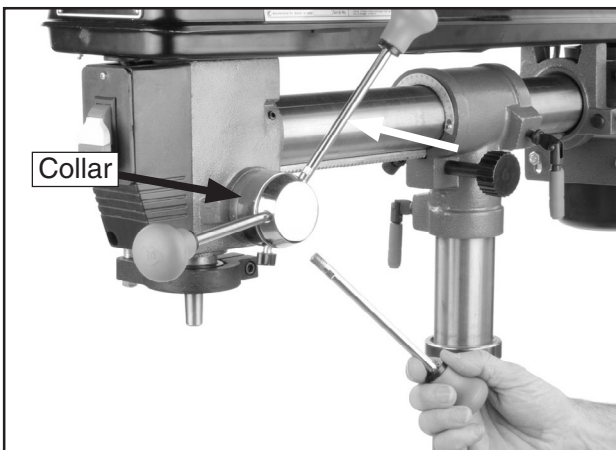

Figure 13. Installing downfeed handles.

Drill Chuck and Arbor

The drill chuck is attached to the drill spindle by means of a machined taper between the chuck and spindle nose. An almost permanent assembly is created when properly joined.

To assemble the drill chuck and mount it to the spindle, carefully follow the instructions below:

1. Use mineral spirits to thoroughly clean the drill chuck, arbor, and spindle sockets and dry all surfaces before assembly. **Failure to clean the mating surfaces may cause the tapered fit to loosen during operation, resulting in separation and an unsafe condition.**
2. Use the chuck key provided to adjust the jaws of the chuck until they are well inside the drill chuck body.
3. Slide the chuck onto the spindle end and tap the drill chuck with a rubber or wooden mallet to seat it as shown in **Figure 14**.

⚠ CAUTION

DO NOT use a steel hammer on the drill chuck to seat it onto the spindle. Damage will occur to the chuck and/or spindle which may make them unusable or unsafe.



Figure 14. Seating chuck into spindle. (Note retracted jaws.)



Test Run

Once assembly is complete, you are ready to test run the drill press.



To test run the drill press:

1. Turn the power supply **ON** at the main panel.
2. With your finger poised on the paddle switch (in case there is a problem), flip the START button **ON**. The drill press should run smoothly, with little or no vibration or rubbing noises.

Investigate and correct for strange or unusual noises before operating the machine further.

If you cannot easily locate the source of a potential problem, refer to **Troubleshooting** on **Page 32**. If you still can't solve the problem, contact our Technical Support at (570) 546-9663.

Mounting

The Model G7945 should be secured to a bench. The Model G7946 base should be secured to the floor.

Bench Mounting

Components and Hardware Needed:	Qty
Assembled Drill Press	1
1/2" Mounting Hardware (Not Included)	Varies

To mount the G7945 drill press to a table:

1. Clamp the base on a bench top capable of holding approximately 100 lbs. plus the weight of the workpiece using two clamps. Make sure the surface is flat and stable.
2. Using holes in the base as a guide (**Figure 15**), drill and bolt the base to the bench top using 1/2" lag bolts, or hex bolts, flat washers, and hex nuts.

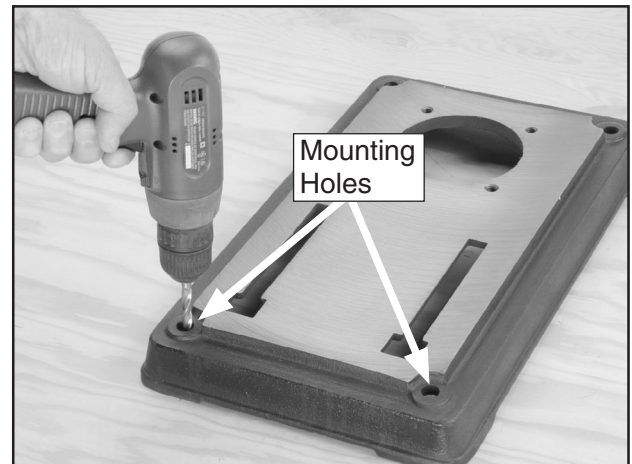

Figure 15. Using holes as a drilling guide.



Floor Mounting

Once you have confirmed that your Model G7946 is running properly, we strongly recommend mounting it to the floor to ensure optimum stability.

Lag shield anchors with lag bolts and anchor studs (**Figure 16**) are two popular methods for anchoring an object to a concrete floor. We suggest you research the many options and methods for mounting your machine and choose the best that fits your specific application.

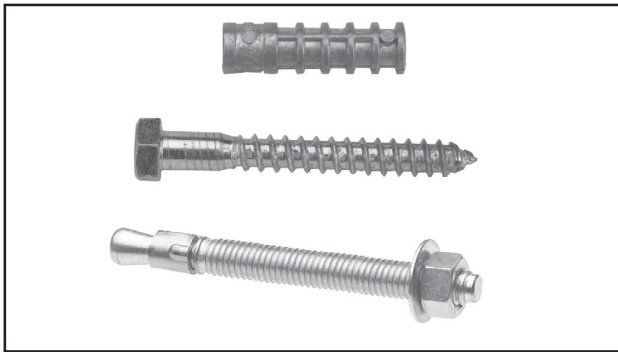

Figure 16. Typical concrete mounting hardware.

Mobile Base Mounting

Because the Model G7946 drill press is top-heavy by nature, we recommend mounting it to the floor, rather than a mobile base.

If you must use a mobile base, ALWAYS mount your drill press to a base plate inside of the mobile base, as shown in **Figure 18**.

A good quality base plate increases the standard footprint of the drill press to make it much more stable. The base plate must be at least 1½" thick and made of plywood (do not use OSB, MDF, or particle board) to hold the weight of the drill press. A common way for making the baseplate is described in this sub-section.

⚠ CAUTION

Drill presses are top-heavy and must be securely attached to a large-footprint base plate when used with a mobile base. Failure to use a base plate greatly increases possibility of tipping and personal injury.

Needed Materials for Base Plate

Qty

- Plywood ¾" x 23¾" x 23¾" 2
- Wood Glue As Needed
- Wood Screws #6 x 1¼" 24
- Mounting Hardware Varies

To make and use the base plate:

1. Glue the two pieces of plywood together, and align the edges and corners so the two boards make one thick piece.
2. Use the wood screws to fasten the boards together from both sides.
3. Allow 24 hours for the glue to dry before placing the drill press on it.
4. Place the base plate on the mobile base.
5. Drill holes through the base plate and the metal plates at the corners of the mobile base.
6. Secure the base plate to the mobile base with hex bolts, hex nuts, flat washers and lock washers, as shown in **Figure 17**.

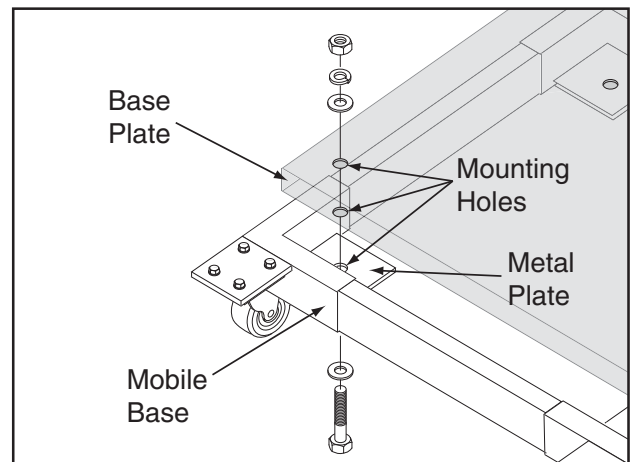

Figure 17. Mounting base plate to mobile base.



Note: Use 2" to 2¼" long hex bolts.

7. Place the drill press on the base plate.
8. Position the drill press close to the front of the mobile base, so the mobile base will not be a tripping hazard.
9. Mount the drill press to the base plate with lag bolts and flat washers (**Figure 18**); or with through bolts, flat washers, and hex nuts.

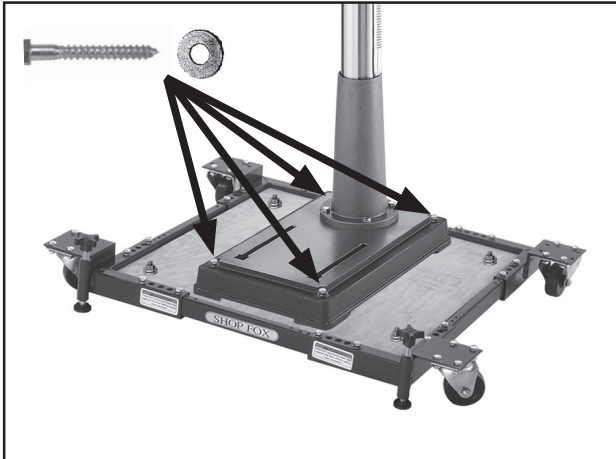

Figure 18. Drill press mounted on mobile base, using a base plate for support.

Recommended Adjustments

For your convenience, the adjustments listed below have been performed at the factory; however, because of the many variables involved with shipping, we recommend that you at least verify the following adjustments before operating your machine—this will ensure that you know the operating tolerances of your machine, and you have them adjusted to your expectation.

Step-by-step instructions for these adjustments can be found in **SECTION 7: SERVICE**.

Factory adjustments that should be verified:

1. Depth Stop Calibration (**Page 34**)
2. Feed Shaft Spring Tension (**Page 34**)



SECTION 4: OPERATIONS

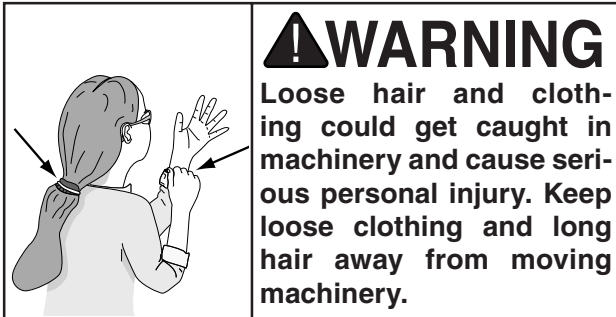

NOTICE

If you have never used this type of machine or equipment before, **WE STRONGLY RECOMMEND** that you read books, trade magazines, or get formal training before beginning any projects. Regardless of the content in this section, Grizzly Industrial will not be held liable for accidents caused by lack of training.

Switch/Safety Key

The ON/OFF switch can be disabled to prevent unauthorized use.

To use the switch:

1. To turn the drill press **ON**, flip the switch up.
2. To turn the drill press **OFF**, press the switch down.
3. To disable the switch, remove the yellow key from the switch housing, as shown in **Figure 19**. Place the key in a safe place.

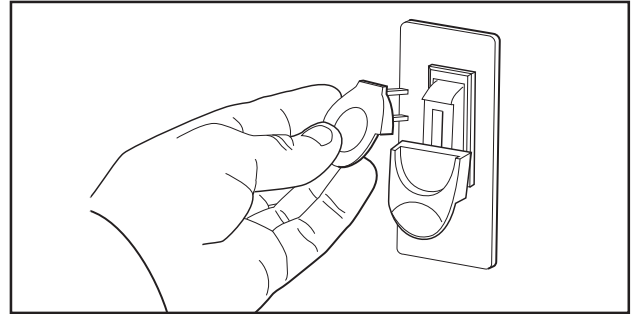

Figure 19. Disabling switch.

Installing/Removing Drill Bits

Any drill bit you install in the chuck must be tight enough that it will not come loose during operation.

To install a drill bit:

1. UNPLUG THE DRILL PRESS!
2. Open the drill chuck wide enough to accept the shank of the drill bit.
3. Insert the drill bit as far as possible into the chuck **WITHOUT** allowing the chuck jaws to touch the fluted portion of the bit, and hand tighten the chuck.

Note: Make sure small bits are not trapped between the edges of two jaws; if they are, reinstall the drill bit or it will not be secure enough to use for drilling.

4. Final tighten the drill bit with the chuck key and remove the chuck key.

To remove a drill bit:

1. UNPLUG THE DRILL PRESS!
2. Use the chuck key to open the chuck, and catch the bit with a rag to protect your hands.



Choosing Speeds

Using the Drill Bit Speed Chart

The chart shown in **Figure 20** is intended as a guide only. Always follow the manufacturer's speed recommendations if provided with your drill bits, cutters, or hole saws. Exceeding the recommended speeds may be dangerous to the operator.

The speeds shown here are intended to get you started. The optimum speed will always depend on various factors, including tool diameter, drilling pressure, material hardness, material quality, and desired finish.

Often, when drilling materials other than wood, some type of lubrication is necessary.

Lubrication Suggestions

Wood/Cast Iron.....None
 Plastics.....Soapy Water
 Brass.....Water-Based Lubricant
 Aluminum.....Paraffin-Based Lubricant
 Mild Steel.....Oil-Based Lubricant

CAUTION

Larger bits turning at slower speeds tend to grab the workpiece aggressively. This can result in the operator's hand being pulled into the bit or the workpiece being thrown with great force. Always clamp the workpiece to the table to prevent injuries.

Twist/Brad Point Drill Bits	Soft Wood	Hard Wood	Plastic	Brass	Aluminum	Mild Steel
1/16" – 3/16"	3000	2500	2500	2500	3000	2500
13/64" – 3/8"	2000	1500	2000	1250	2500	1250
25/64" – 5/8"	1500	750	1500	750	1500	600
11/16" – 1"	750	500	1000	400	1000	350

Spade/Forstner Bits	Soft Wood	Hard Wood	Plastic	Brass	Aluminum	Mild Steel
1/4" – 1/2"	2000	1500				
9/16" – 1"	1500	1250				
1-1/8" – 1-7/8"	1000	750				
2–3"	500	350				

Hole Saws	Soft Wood	Hard Wood	Plastic	Brass	Aluminum	Mild Steel
1/2" – 7/8"	500	500	600	600	600	500
1" – 1-7/8"	400	400	500	500	500	400
2" – 2-7/8"	300	300	400	400	400	300
3" – 3-7/8"	200	200	300	300	300	200
4" – 5"	100	100	200	200	200	100

Rosette Cutters	Soft Wood	Hard Wood	Plastic	Brass	Aluminum	Mild Steel
Carbide Insert Type	350	250				
One-Piece Type	1800	500				

Tenon/Plug Cutters	Soft Wood	Hard Wood	Plastic	Brass	Aluminum	Mild Steel
3/8" – 1/2"	1200	1000				
5/8" – 1"	800	600				

Figure 20. Drill bit speed chart.



Changing Speeds

The belt in the head of the drill press must be rearranged to change speeds. A chart under the pulley cover shows the belt positions needed to make the drill press run at the desired speed.

To change speeds:

1. UNPLUG THE DRILL PRESS!
2. Loosen the belt tension lock knobs (shown in **Figure 21**) on both sides of the headstock, so the motor is free to move.

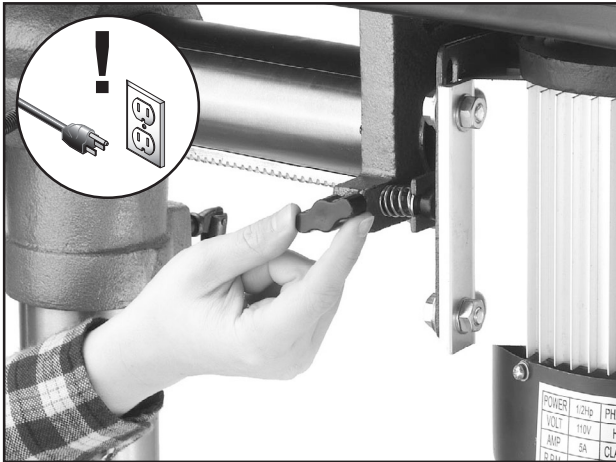

Figure 21. Loosening lock knob (both sides).

3. Locate the desired speed on the speed chart under the pulley cover, and move the V-belt to the desired V-grooves on the motor and spindle pulleys.

4. Pivot the motor toward the back of the headstock and tighten the lock knobs once the desired V-belt tension is achieved.
5. Close the cover before plugging in the machine.

!WARNING

Never operate drill press with pulley cover in the open position. Your hand may become trapped in the belt and serious personal injury will occur.



Drilling

The Model G7945/G7946 is designed for drilling holes in wood or metal. The basic operation of a drill press is lining up your drill bit with the intended hole location, turning the drill press **ON**, and using the down feed levers to move the spinning drill bit into the workpiece.

For safe operation and optimum results, it is very important to follow these guidelines when drilling:

CLEARING CHIPS: Raise the drill bit often to clear chips and cool the drill bit. This will ease the work of the drill press motor and extend the life of your drill bits.

SECURING WORKPIECE TO TABLE: Secure the workpiece to the table or in a vise that is secured to the table before drilling.

PROTECTING TABLE: Protect the table by placing the workpiece on scrap wood, or center the location of the hole to be drilled over the pocket in the table when through drilling. Also, make use of the depth stop so that the drill bit goes no deeper than necessary.

USING CORRECT SPEEDS: Use the correct speed for the diameter of the drill bit being used and the type of material being drilled. Refer to the **Drill Bit Speed Chart** on **Page 23** to help you choose the correct speed for your application.

LARGE DIAMETER BITS: Large diameter drill bits require slower spindle speeds.

SMALL DIAMETER BITS: Smaller diameter drill bits require faster spindle speeds.

HARD MATERIAL: The harder the material, (steel vs. wood) the slower the spindle speed.

SOFT MATERIAL: The softer the material, the faster the spindle may turn. (Plastics can melt at too high of a spindle speed!)

LUBRICANT: Use some form of lubricant on all materials except wood and cast iron. Refer to **Lubrication Suggestions** on **Page 23** to find the correct lubrication for your application.

DRILLING ACCURACY: To prevent drill bit wandering and ensure accurate placement of holes, mark the hole location with a center punch before drilling. Also consider using a center-point drill to start the hole.

PLUG/ROSETTE CUTTERS: Plug cutters and rosette cutters are for wood only.

5-FLUTE/2-FLUTE CUTTERS: Use a 5-flute cutter when cutting into plastics, brass, aluminum, and mild steel. A 2-flute cutter can aggressively grab the workpiece and damage the tool if used with materials other than wood.

SPADE BITS AND PLASTIC: When drilling plastic with a spade bit, use a spade bit with spurs.

HOLE SAWS: When using hole saws, apply firm and even pressure, so the saw teeth contact the surface all at the same time—not at an angle. You can also flip the workpiece and finish drilling from the other side.

CAUTION

Larger bits turning at slower speeds tend to grab the workpiece aggressively. This can result in the operator's hand being pulled into the bit or the workpiece being thrown with great force. Always clamp the workpiece to the table to prevent injuries.



Depth Stop

The Model G7945/G7946 has a depth stop that allows you to drill repeated non-through holes to the same depth every time.

Depth Stop

The depth stop consists of a stud attached to the quill with two hex nuts that can be lowered or raised on the stud so the lower nut (depth nut) hits a stop bracket when the drill bit is lowered. The upper hex nut (jam nut) is then used to tighten against the depth nut to secure it in place so it doesn't move with repeated operations. **Figure 22** shows the various components of the depth stop.

The return height nut, on the base of the stud, limits the downfeed handle return distance, which is set by how high the nut is placed on the stud. This feature is useful for repetitive drilling motions.

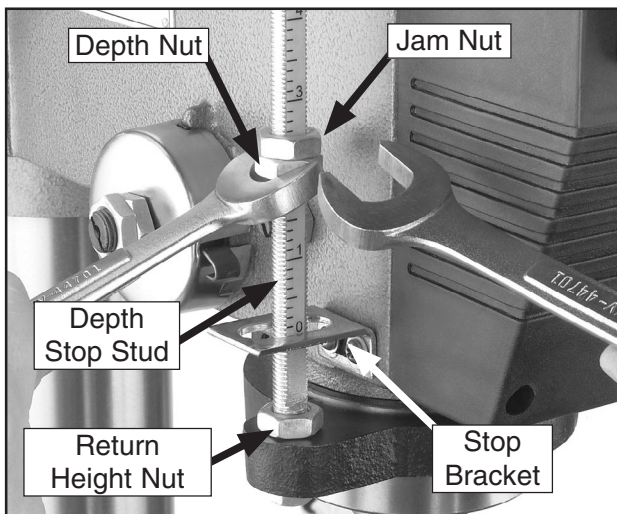

Figure 22. Depth stop components.

To set the depth stop:

1. Lower the drill bit to the required height.
2. Thread the depth nut down against the stop bracket.
3. Lower the jam nut against the depth nut.
4. Using wrenches, hold the depth nut in place and tighten the jam nut against the depth nut.

To set the spindle return distance:

1. Lower the drill bit.
2. Thread the return height nut up the stud to the desired height.

Note: The scale on the depth stop can be recalibrated if it gets moved or has changed since the factory setting. Refer to **Depth Stop Calibration** on **Page 34** for instructions on how this is done.

Table Adjustments

The Model G7945 table can be adjusted for height and angle. The G7946 table adds the adjustments of table distance from column and rotation.

Table Height

1. Loosen the table bracket clamp bolt (**Figure 23**). Turn the handle crank to lift or lower the table.
2. Remember to lock the support bracket in place before operating the machine.

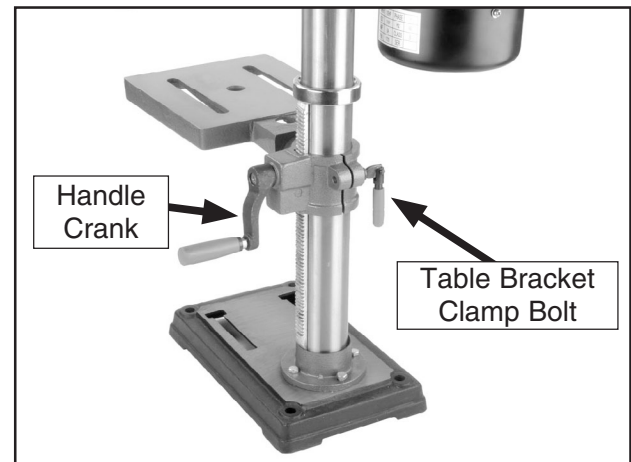

Figure 23. Table height controls (G7945).



Table Tilt

With the Model G7946, start at **Step 1**. With the Model G7945 start at **Step 2**.

1. Turn the locating pin nut (**Figure 24**), in a clockwise direction. This will draw the locating pin out of the casting. Once loose, pull out the pin and nut, and set them in a safe place until needed.

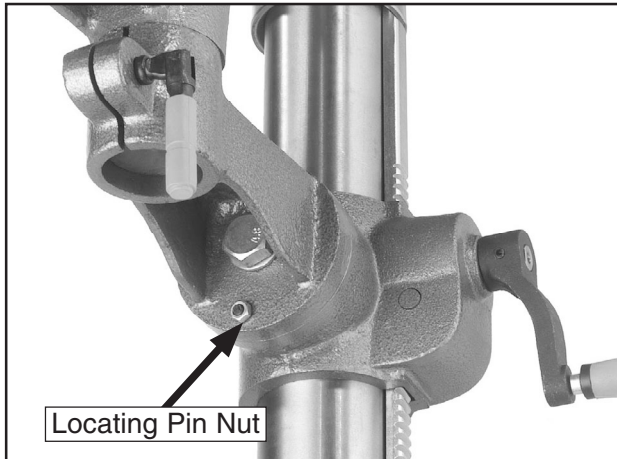

Figure 24. Locating pin and nut (G7946).

2. Loosen the lock bolt (**Figure 25**) using the included wrench and tilt the table (G7945) or the column support arm (G7946) to the desired angle.

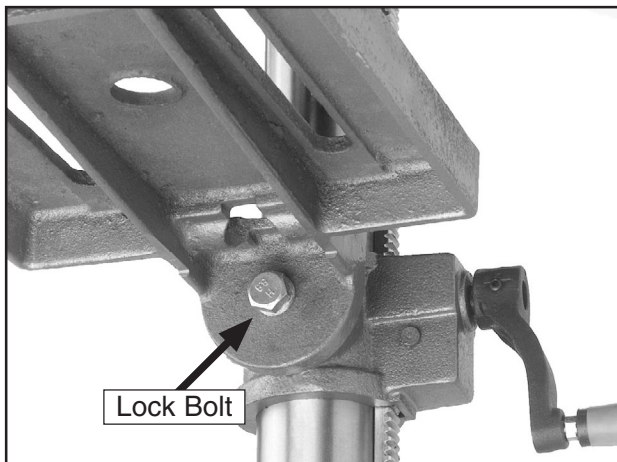

Figure 25. Angle adjustment bolt (G7945).

3. Lock in place by tightening the lock bolt.
4. To return the table to its original position, align the holes in the column support arm and the table bracket, insert the locating pin and nut, and gently tap the pin with a hammer.
5. Tighten the nut.

Table Rotation

(Note: *The following steps only apply to the G7946.*)

1. Loosen the clamp bolt located under the table **26**. Rotate the table the desired amount.
2. Always lock the table support arm in place before operating the machine.

Distance from Column

(Note: *The following steps only apply to the G7946.*)

1. Loosen the clamp bolt located at the pivoting elbow of the table support (**Figure 26**).

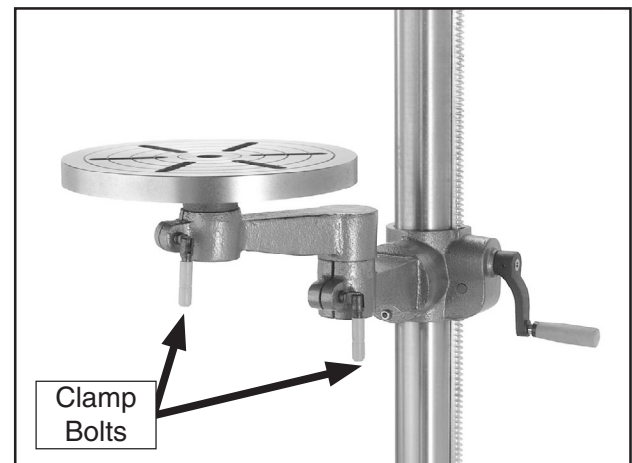

Figure 26. Adjusting distance from column.

2. Swing the table support to the desired distance from the column. The support bracket may need to be rotated around the column to keep the table centered under the chuck. Secure all clamp bolts before operating the machine.



Head Adjustments

The headstock can be tilted from 45° clockwise to 90° counterclockwise.

To tilt the headstock:

1. Loosen the clamp bolt on the right side of the headstock.
2. Pull out the guide pin located on the left side of the headstock and rotate the pin 90° as shown in **Figure 27**.

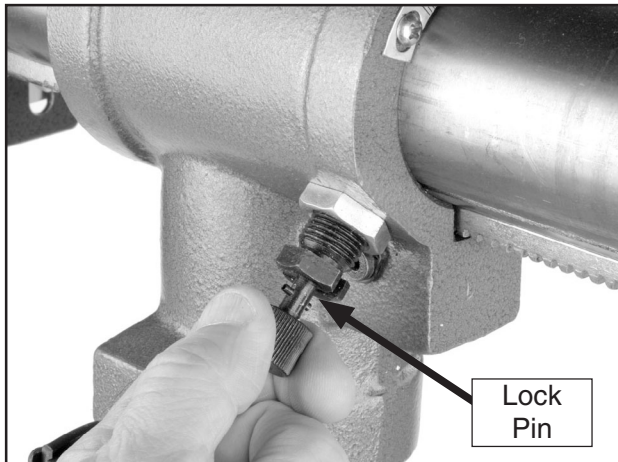

Figure 27. Lock pin location.

3. Tilt the headstock to the desired angle specified on the scale and tighten the clamp bolt on the right side of the headstock.

To return to vertical position:

1. Loosen the clamp bolt located on the right side of the headstock.
2. Move the lock pin back into the guide slot.
3. Return the headstock to the vertical position. The headstock should lock into place.

Note: *The lock pin is only intended to be a rough indexing tool.*

4. For finer adjustments, align the zero mark on the headstock scale with the line on the horizontal column.
5. Tighten the clamp bolt.

To adjust the headstock back and forth:

1. Loosen the clamp bolt located on the right side of the headstock.
2. Turn the black ribbed handle to move the headstock back and forth to the desired position. Tighten the clamp bolt before operating the machine.



SECTION 5: ACCESSORIES

G2500—20-PC Regular Sanding Drum Set

Use on your drill press, lathe, or hand drill. This kit consists of 5 drums in popular 1/2" x 1/2", 3/4" x 1", 1" x 1", 1 1/2" x 1 1/2", and 2" x 1 1/2" sizes. Comes with 50, 80 and 120 grit sizes for each drum.



Figure 28. Model G2500 20-PC Sanding Drum Set.

G5753—Drill Press Vise 6"

If you use a drill press and value your fingers, you need one of these. Made from high-grade cast iron, these hefty horizontal vises offer support and stability, allowing you to keep your hands well away from fast moving bits and cutters.

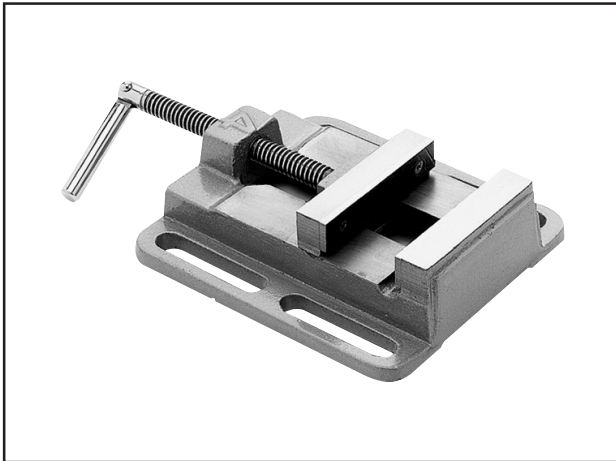

Figure 29. Model G5753 Drill Press Vise 6".

G8581—1/2" Keyless Drill Chuck JT #33

Industrial grade keyless chucks are excellent for quick bit changes. Knurled grips and exceptional accuracy make these chucks an indispensable part of any shop. Use on drill presses, lathe tailstocks and milling machines. 0 – 1/2" capacity with a Jacobs Taper #33 in back.



Figure 30. Model G8581 1/2" Keyless Drill Chuck JT #33.

G5562—SLIPIT® 1 Qt. Gel

G5563—SLIPIT® 12 oz Spray

G2871—Boeshield® T-9 12 oz Spray

G2870—Boeshield® T-9 4 oz Spray

H3788—G96® Gun Treatment 12 oz Spray

H3789—G96® Gun Treatment 4.5 oz Spray



Figure 31. Recommended products for protecting unpainted cast iron/steel areas.

Call 1-800-523-4777 To Order



T20501—Face Shield Crown Protector 4"
T20502—Face Shield Crown Protector 7"
T20503—Face Shield Window
T20452—"Kirova" Anti-Reflective S. Glasses
T20451—"Kirova" Clear Safety Glasses
H0736—Shop Fox® Safety Glasses
H7194—Bifocal Safety Glasses 1.5
H7195—Bifocal Safety Glasses 2.0
H7196—Bifocal Safety Glasses 2.5



Figure 32. Eye protection assortment.

H2499—Small Half-Mask Respirator
H3631—Medium Half-Mask Respirator
H3632—Large Half-Mask Respirator
H3635—Cartridge Filter Pair P100
 Wood dust has been linked to nasal cancer and severe respiratory illnesses. If you work around-dust everyday, a half-mask respirator can be a lifesaver. Also compatible with safety glasses!



Figure 33. Half-mask respirator with disposable cartridge filters.

G8865—Cobalt Alloy Drill Bits 13-PC. Set
G8866—Steelex® Cobalt Alloy Drill Bits 21-PC
G8867—Steelex® Cobalt Alloy Drill Bits 29-PC
 Cobalt Alloy bits will retain their edge sharpness longer than normal HSS bits, resulting in a significant saving of time and money in the workshop. Includes a heavy-gauge steel index case for storing. G8865: 1/16" -1/4"; G8866: 1/16" - 3/8"; G8867: 1/16" - 1/2". See the Grizzly Catalog for more options.



Figure 34. Model G8865 13-PC Alloy Drill Bits.

H9816—Power Twist® V-Belt 3/8" x 60"
 Smooth running with less vibration and noise than solid belts. The Power Twist® V-belts can be customized in minutes to any size—just add or remove sections to fit your needs. Size: 3/8" x 60"; replaces all "M" sized V-belts. Requires two Power Twist® V-belts to replace the stock V-belts on your Model G7945/G7946. Well worth it!

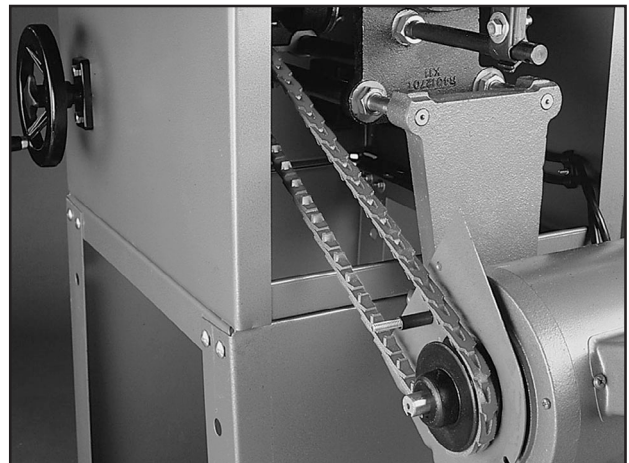

Figure 35. H9816 Power Twist® V-Belt installed.



SECTION 6: MAINTENANCE



General

Regular periodic maintenance on your drill press will ensure optimum performance. Make a habit of inspecting your machine each time you use it. Check for the following conditions and repair or replace when necessary:

- Loose mounting bolts.
- Worn switch.
- Worn or damaged cords and plugs.
- Damaged V-belt.
- Any other condition that could hamper the safe operation of this machine.

Cleaning

Cleaning the Model G7945/G7946 is relatively easy. Vacuum excess wood chips and sawdust, and wipe off the remaining dust with a dry cloth. If any resin has built up, use a resin dissolving cleaner to remove it. Treat all unpainted cast iron and steel with a non-staining lubricant after cleaning.

Unpainted Cast Iron

Protect the unpainted cast iron surfaces by wiping them clean after every use—this ensures moisture from wood dust does not remain on bare metal surfaces.

Keep these surfaces rust-free with regular applications of products like G96® Gun Treatment, SLIPIT®, or Boeshield® T-9 (see **SECTION 5: ACCESSORIES** on **Page 29** for more details).

Lubrication

Since all bearings are shielded and permanently lubricated, simply leave them alone until they need to be replaced. **DO NOT** lubricate them.

Keep quill, spindle, column, and table top well lubricated to prevent rust.

V-Belts

Inspect regularly for tension and wear. Check pulleys to ensure that they are properly aligned. See **Changing Speeds** on **Page 24** for more information about removing/installing belts if you need help replacing the belts.



SECTION 7: SERVICE

About Service

Review the troubleshooting and procedures in this section to fix your machine if a problem develops. If you need replacement parts or you are unsure of your repair skills, then feel free to call our Technical Support at (570) 546-9663.

Troubleshooting

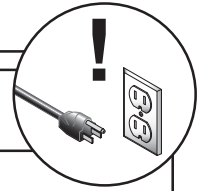

Motor & Electrical

Symptom	Possible Cause	Possible Solution
Machine does not start or a breaker trips.	<ol style="list-style-type: none"> 1. Plug or receptacle is at fault or wired incorrectly. 2. Start capacitor is faulty. 3. Motor connection is wired incorrectly. 4. Power supply is faulty, or is switched OFF. 5. Safety switch key is at fault. 6. ON/OFF switch is faulty. 7. Cable or wiring is open or has high resistance. 8. Motor is at fault. 	<ol style="list-style-type: none"> 1. Test power plug and receptacle for good contact and correct wiring. 2. Replace capacitor. 3. Correct motor wiring (see Page 36). 4. Make sure all hot lines and grounds are operational and have correct voltage on all legs. 5. Install or replace safety key, or replace switch assembly. 6. Replace faulty switch. 7. Troubleshoot wires for internal or external breaks, check for disconnected or corroded connections and repair or replace wiring. 8. Test, repair or replace motor.
Machine stalls or is underpowered.	<ol style="list-style-type: none"> 1. Incorrect spindle speed for task. 2. Machine is undersized for the task. 3. Bit or cutter is dull. 4. Low power supply voltage. 5. Belt is slipping. 6. Plug or receptacle is at fault. 7. Motor connection is wired incorrectly. 8. Pulley is slipping on shaft. 9. Bearings are at fault. 10. Motor has overheated. 11. Motor is at fault. 	<ol style="list-style-type: none"> 1. Decrease spindle speed. 2. Use smaller drill bits/cutters and reduce the feed rate and spindle speed. 3. Sharpen/replace bit or cutter. 4. Make sure hot lines and grounds are operational w/correct voltage. 5. Replace bad belt, align pulleys, and re-tension. 6. Test power plug and receptacle for good contact and correct wiring. 7. Correct motor wiring (see Page 36). 8. Replace loose pulley and shaft. 9. Rotate motor and spindle shaft for noisy or burnt bearings, repair/replace as required. 10. Clean inside/outside of motor, let cool, and reduce workload on machine. 11. Test, repair or replace motor.



Symptom	Possible Cause	Possible Solution
Machine has vibration or noisy operation.	<ol style="list-style-type: none"> 1. Motor or component is loose. 2. Belt is slapping belt cover. 3. V-belt is worn or is loose. 4. Motor fan is rubbing on fan cover. 5. Pulley is loose. 6. Machine is incorrectly mounted to the floor, or the floor is uneven. 7. Chuck or cutter is at fault. 8. Motor bearings are at fault. 9. Spindle bearings at fault. 	<ol style="list-style-type: none"> 1. Inspect, replace for stripped or damaged bolts/nuts, and re-tighten with thread locking fluid. 2. Replace/realign belt and retension (refer to Page 24). 3. Replace belt. 4. Replace/repair dented fan cover, and replace loose or damaged fan. 5. Remove pulley, replace with key as required, and re-install securely. 6. Make sure floor mounting hardware is tight; place shims under machine. 7. Replace out-of-round chuck, replace or sharpen cutter, use appropriate feed rate and cutting RPM. 8. Check bearings, replace motor or bearings as required. 9. Replace bearing.

Drill Press Operations

Symptom	Possible Cause	Possible Solution
Drill bit wobbles, holes are oversized.	<ol style="list-style-type: none"> 1. Drill bit installed incorrectly. 	<ol style="list-style-type: none"> 2. Remove drill bit and reinstall.
The spindle does not retract completely in the uppermost position or it binds.	<ol style="list-style-type: none"> 1. The quill shaft is gummy with sawdust and oil. 2. The feed shaft return spring is weak. 3. The quill deflection screw is binding the quill. 	<ol style="list-style-type: none"> 1. Clean the gummy substance with penetrating oil and lubricate with a light coat of oil. 2. Increase the feed shaft return spring tension as described on Page 34. 3. Loosen the jam nut, and slightly turn out the screw where the quill binds. Retighten the jam nut and recheck for binding and looseness at all spindle locations.
Holes drilled at an angle.	<ol style="list-style-type: none"> 1. Table is not at 90 degrees. 	<ol style="list-style-type: none"> 1. Adjust table angle (see Page 27).

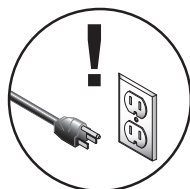

Depth Stop Calibration

The drill press comes fitted with a depth stop to use when drilling multiple holes at the same depth. The scale on this depth stop can be calibrated if it ever becomes incorrect.

To calibrate the depth stop:

1. Loosen the return height nut and calibration nut shown in **Figure 36**.

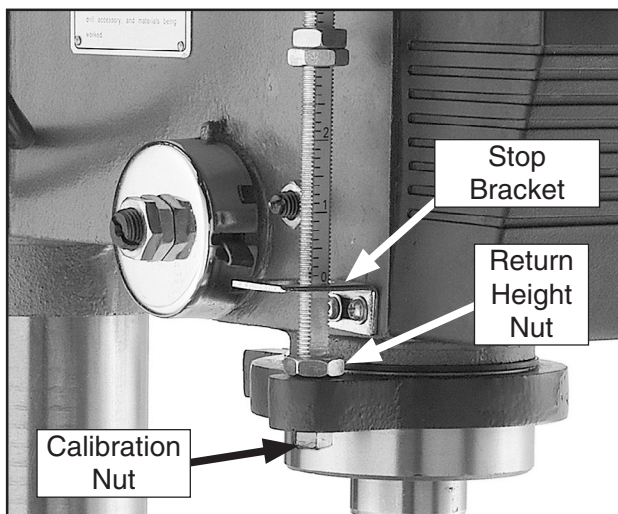

Figure 36. Depth stop assembly.

2. Use the calibration nut to zero the depth stop scale with the stop bracket.
3. Hold the depth stop at zero, and tighten the return height nut to hold the depth stop in position.
4. Test the depth stop by measuring how far the spindle actually moves with respect to where you set the depth stop.

Feed Shaft Spring Tension

The feed shaft return spring is adjusted at the factory; however, during the life of the drill press you may want to adjust the feed shaft return spring so the feed shaft return pressure suits your operating needs.



To adjust the feed shaft spring tension:

1. UNPLUG THE DRILL PRESS!
2. Wipe off any oil on the spring lock cover so it does not slip in your fingers when you hold the cover from spinning (see **Figure 37**).

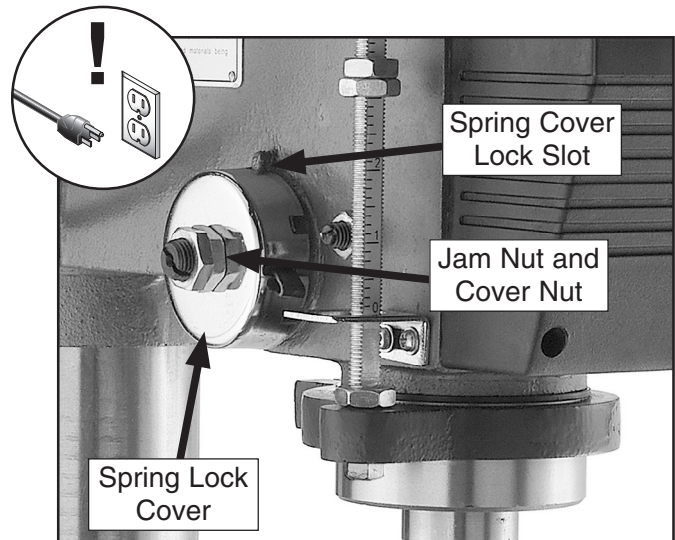

Figure 37. Feed shaft return spring assembly.



3. While holding the spring lock cover against the side of the headstock so the cover stays splined with the locking lug; loosen the jam nut and loosen the cover nut approximately $\frac{1}{4}$ " (see **Figure 38**).



Figure 38. Loosening cover and jam nut.

⚠ CAUTION

A high tension coiled spring is underneath the cover. Put on heavy leather gloves to protect yours hands from possible lacerations when removing the cover.

4. Put on heavy leather gloves to protect your hands from possible lacerations if the spring uncoils during the next step.
5. Pull the cover outward just enough to disengage the spring-cover lock slot from the locking lug. **Note:** *It is important to keep a good grip during this step. Letting go of the cover will cause the spring to rapidly uncoil.*
6. Rotate the cover counterclockwise to increase spring tension, or let the cover slowly unwind in the clockwise direction to reduce spring tension.
7. Engage the next available spring-cover lock slot with the locking lug and hold the spring lock cover tightly against the side of the headstock.
8. Snug the cover nut against the spring cover just until the nut stops, and then back off the nut approximately $\frac{1}{3}$ turn, or just enough so there is no binding at complete spindle travel.
9. Hold the cover nut and tighten the jam nut against the cover nut.

Electrical Components

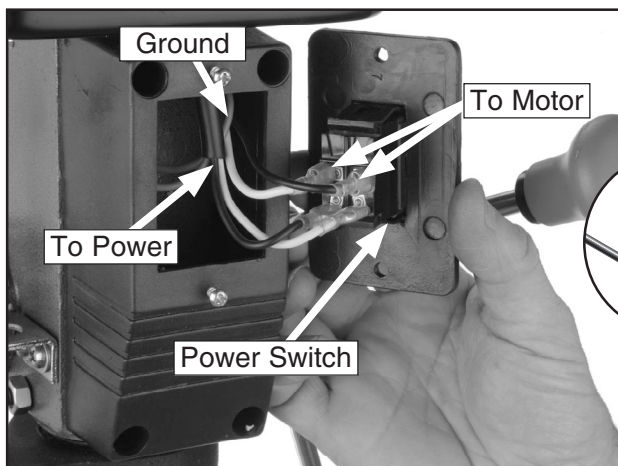

Figure 39. Power switch wiring.

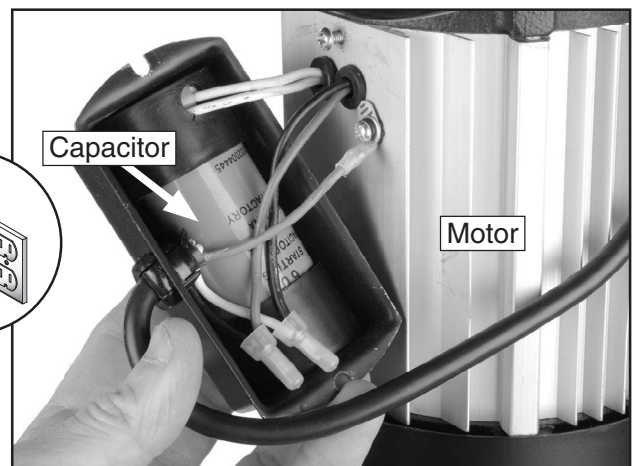
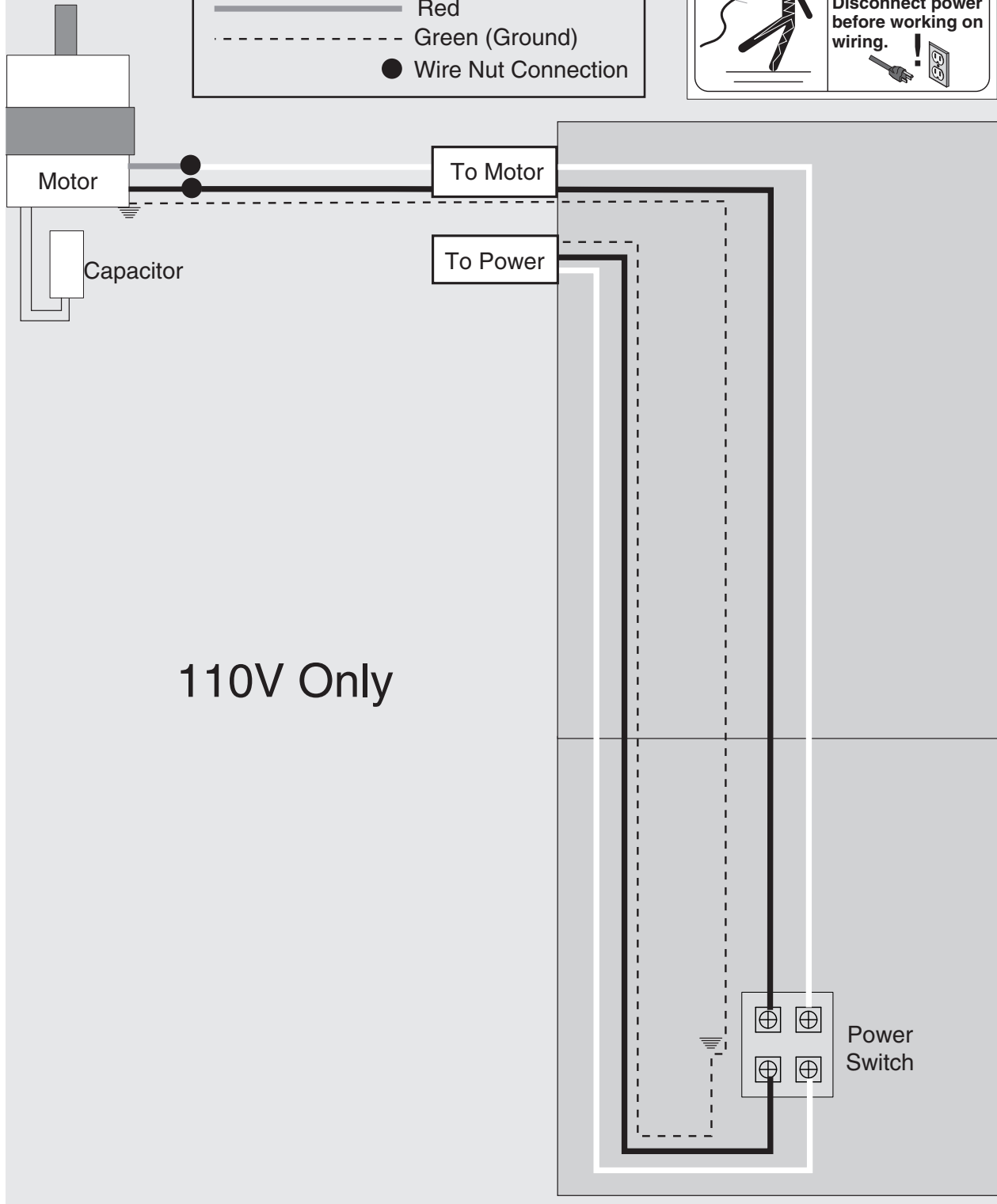
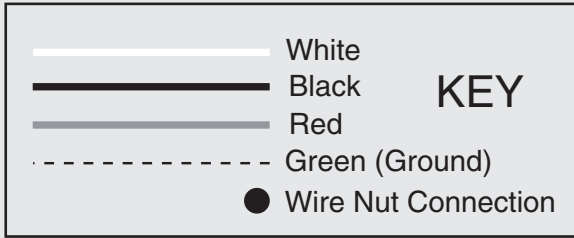
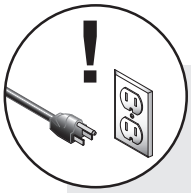

Figure 40. Motor wiring.



G7945/G7946 Wiring Diagram



G7945/G7946 Main Parts Breakdown

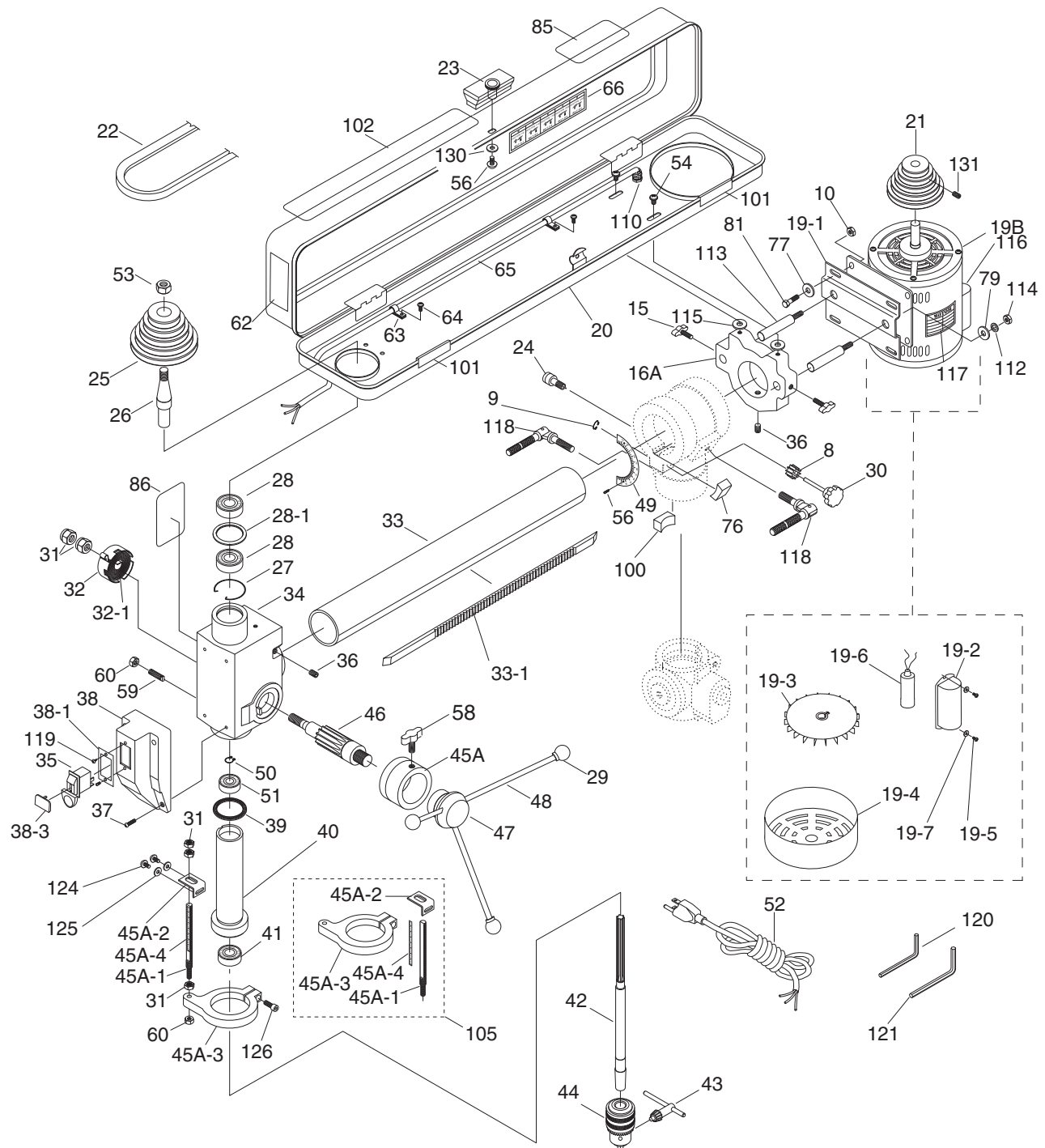

G7945/G7946 Main Parts List

REF	PART #	DESCRIPTION
8	P7945008	GEAR
9	PR16M	EXT RETAINING RING 9MM
10	PN03M	HEX NUT M8-1.25
15	P7945015	KNOB BOLT M8-1.25 X 16
16A	P7945016A	MOUNT PLATE V2.06.06
19B	P7945019B	MOTOR 1/2HP 110V V2.3.07
19-1	P7945019-1	MOTOR MOUNT BRACKET V2.02.05
19-2	P7945019-2	CAPACITOR COVER
19-3	P7945019-3	MOTOR FAN
19-4	P7945019-4	FAN COVER
19-5	PS17M	PHLP HD SCR M4-.7 X 6
19-6	P7945019-6	CAPACITOR 150 MFD, 125VAC
19-7	PW05M	FLAT WASHER 4MM
20	P7945020	PULLEY COVER
21	P7945021	MOTOR PULLEY
22	PVM58	V-BELT M-58 3L580
23	P7945023	COVER KNOB M5-.8
24	P7945024	LOCK PIN
25	P7945025	SPINDLE PULLEY
26	P7945026	DRIVE SLEEVE
27	PR23M	INT RETAINING RING 40MM
28	P6203	BALL BEARING 6203ZZ
28-1	P7945028-1	SPACER
29	P7945029	KNOB M10-1.5
30	P7945030	HORIZONTAL ADJ KNOB
31	PN31M	HEX NUT M12-1.5
32	P7945032	SPRING COVER
32-1	P7945032-1	COILED SPRING
33	P7945033	HORIZONTAL COLUMN
33-1	P7945033-1	HORIZONTAL COLUMN RACK
34	P7945034	HEADSTOCK
35	PSW06	SWITCH 110/220V
36	PSS20M	SET SCREW M8-1.25 X 8
37	PS09M	PHLP HD SCR M5-8 X 10
38	P7945038	SWITCH MOUNT COVER
38-1	P7945038-1	SWITCH PLATE
38-3	PSW09-1	PADDLE SWITCH KEY
39	P7945039	RUBBER WASHER
40	P7945040	QUILL SHAFT
41	P6202	BALL BEARING 6202ZZ
42	P7945042	SPINDLE SHAFT JT #33
43	P7943092	CHUCK KEY
44	P7945044	1/2" CHUCK 1-16MM JT #33
45A	P7945045A	COLLAR

REF	PART #	DESCRIPTION
45A-1	P7945045A-1	DEPTH STOP ROD V2.02.05
45A-2	P7945045A-2	DEPTH STOP BRACKET
45A-3	P7945045A-3	DEPTH STOP MOUNT
45A-4	P7945045A-4	DEPTH STOP SCALE
46	P7945046	PINION
47	P7945047	FEED COLLAR
48	P7945048	HANDLE
49	P7945049	DEGREE SCALE
50	PR03M	EXT RETAINING RING 12MM
51	P6201	BALL BEARING 6201
52	P7945052	POWER CORD
53	P7945053	PULLEY SET NUT
54	PS07	PHLP HD SCR 1/4-20 X 3/8
56	PS05M	PHLP HD SCR M5-.8 X 8
58	P7945058	LOCK KNOB M8-1.25 X 15
59	PSS21M	SET SCREW M8-1.25 X 25
60	PN03M	HEX NUT M8-1.25
62	P7945062	LOGO
63	P7945063	WIRE STRAP
64	PS07M	PHLP HD SCR M4-.7 X 8
65	P7945065	MOTOR SWITCH CORD
66	P7945066	SPEED CHART
76	P7945076	LOCKING GIB
77	PW01M	FLAT WASHER 8MM
79	PW04M	FLAT WASHER 10MM
81	PB09M	HEX BOLT M8-1.25 X 20
100	P7945100	LOCK SHOE
101	P7945101	RUBBER BUMPER
105	P7945105	DEPTH GAUGE KIT V2.05.02
110	P7945110	STRAIN RELIEF
112	PLW06M	LOCK WASHER 10MM
113	P7945113	GUIDE ROD 16 X 30MM
114	PN02M	HEX NUT M10-1.5
115	P7942031	RUBBER WASHER 7MM
117	P7945117	MOTOR LABEL
118	P7945118	CLAMP BOLT M10-1.5 X 25
119	PHTEK7	TAP SCREW #8 X 3/8
120	PAW03M	HEX WRENCH 3MM
121	PAW04M	HEX WRENCH 4MM
124	PS03M	PHLP HD SCR M6-1 X 8
125	PW03M	FLAT WASHER 6MM
126	PSB14M	CAP SCREW M8-1.25 X 20
130	PW02M	FLAT WASHER 5MM
131	PSS01M	SET SCREW M6-1 X 10



G7945 Column Breakdown

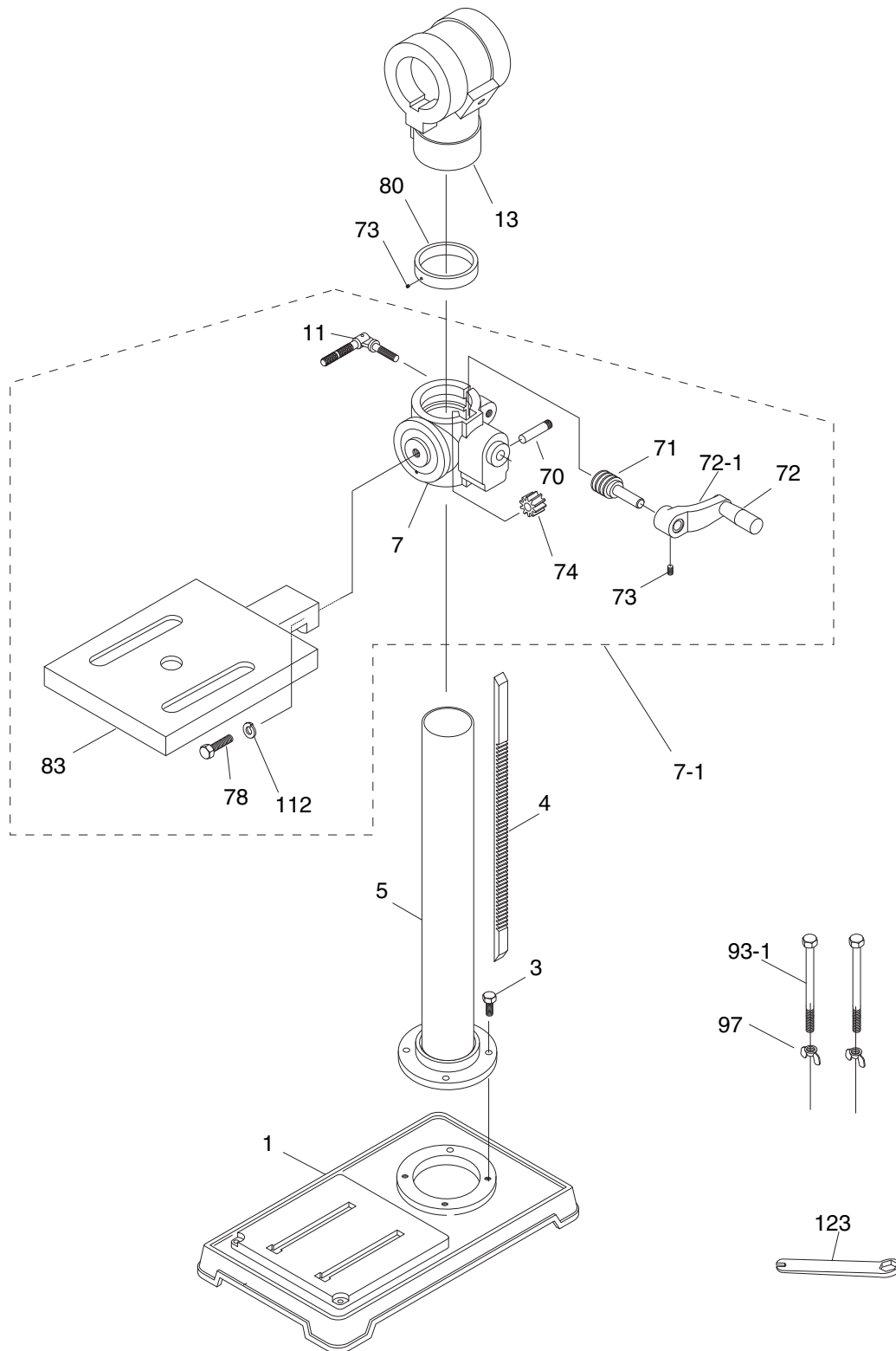

G7946 Column Breakdown

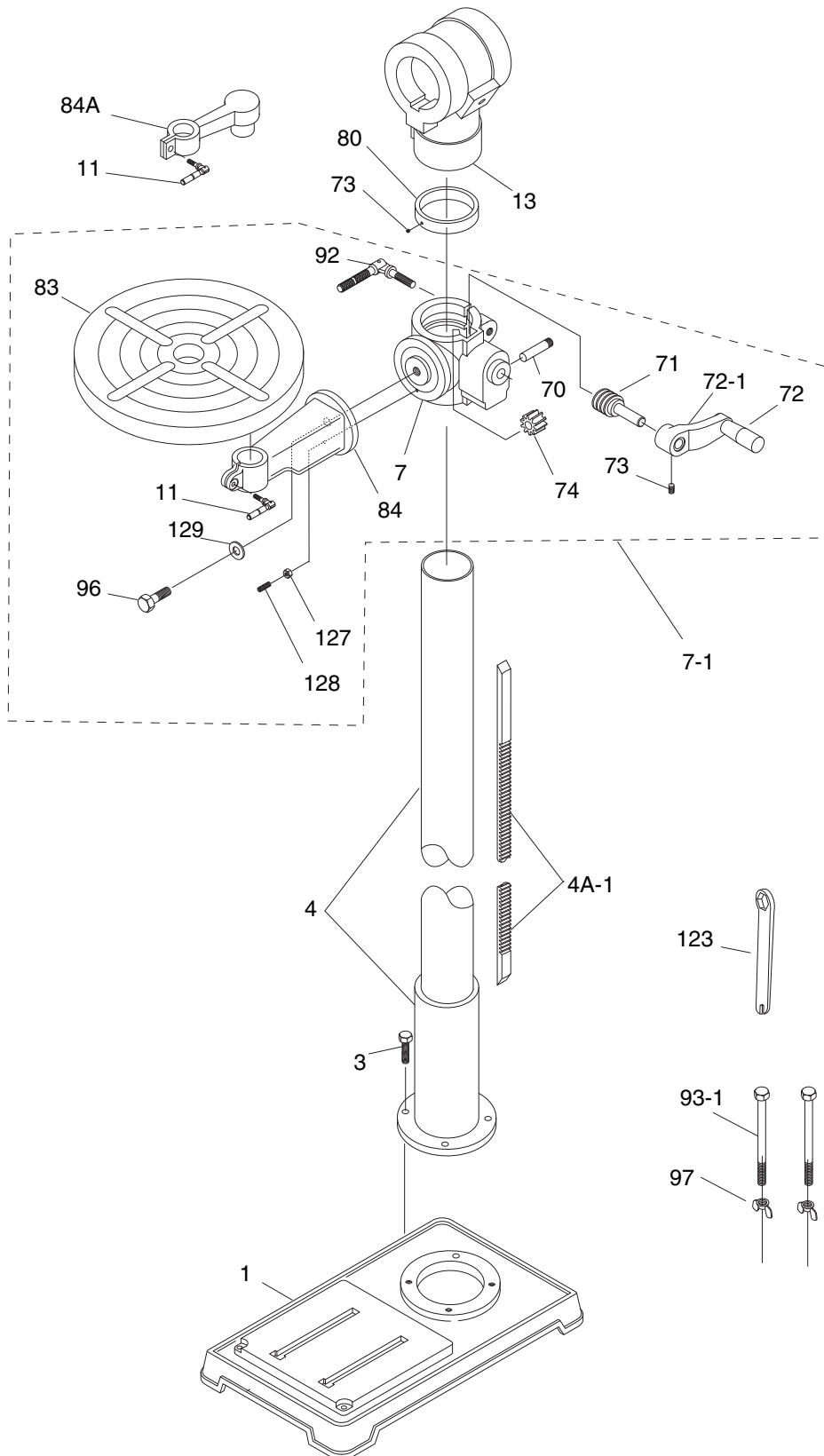

G7945 Column Parts List

REF	PART #	DESCRIPTION
1	P7945001	BASE
3	PB09M	HEX BOLT M8-1.25 X 20
4	P7945004	SHORT RACK
5	P7945005	SHORT VERTICAL COLUMN
7	P7945007	GEARED TABLE BRACKET
7-1	P7945007-1	TABLE BRACKET ASSEMBLY
11	P7945011	CLAMP BOLT M10-1.5 X 30
13	P7945013	HORIZ BRACKET 2-5/16 V2.02.99
70	P7945070	PIN
71	P7945071	WORM SHAFT
72	P7943006	HANDLE

REF	PART #	DESCRIPTION
72-1	P7945072-1	CRANK HANDLE
73	PSS01M	SET SCREW M6-1 X 10
74	P7945074	10T GEAR
78	P7945078	10MM CAPSCREW
80	P7945080	COLUMN RING
83	P7945083	SQUARE TABLE
93-1	P7945093-1	HEX BOLT M8-1.25 X 125
97	P7945097	WING NUT 8MM
112	PLW06M	LOCK WASHER 10MM
123	P7945123	SPECIAL WRENCH

G7946 Column Parts List

REF	PART #	DESCRIPTION
1	P7946001	BASE V2.04.03
3	PB31M	HEX BOLT M10-1.5 X 40
4	P7946004	LONG COLUMN W/HOLDER V3.02.99
4A-1	P7946004A	LONG RACK
7	P7946007	GEARED TABLE BRACKET V2.03.99
7-1	P7946007-1	COMPLETE TBL BRKT ASSY
11	P7946011	LEVER BOLT M10-1.5 X 30
13	P7946013	HORIZONTAL COLUMN BRACKET
70	P7946070	AXLE
71	P7946071	WORM PINION
72	P7946072	LIFT HANDLE
72-1	P7946072-1	CRANK HANDLE
73	PSS01M	SET SCREW M6-1 X 10

REF	PART #	DESCRIPTION
74	P7946074	WORM GEAR
80	P7946080	COLUMN RING
83	P7946083	ROUND TABLE
84	P7946084	COLUMN SUPPORT ARM
84A	P7946084A	TABLE SUPPORT ARM
92	P7946092	CLAMP BOLT M12-1.75 X 50
93-1	P7946093-1	HEX BOLT M8-1.25 X 125
96	P7946096	HEX BOLT 5/8-13 X 1-1/2
97	P7945097	WING NUT 8MM
123	P7946123	SPECIAL WRENCH
127	PN01M	HEX NUT M6-1
128	P7946128	LOCATING PIN
129	PW08M	FLAT WASHER 16MM



Safety Label Placement and Parts List

⚠️ WARNING

The safety labels on this machine warn and indicate how to protect the operator or bystander from machine hazards. The machine owner **MUST** maintain the original label location and readability. If a label is removed or becomes unreadable, **REPLACE** the label before using the machine. For new labels, contact Grizzly Industrial Inc. at (570) 546-9663 or techsupport@grizzly.com.

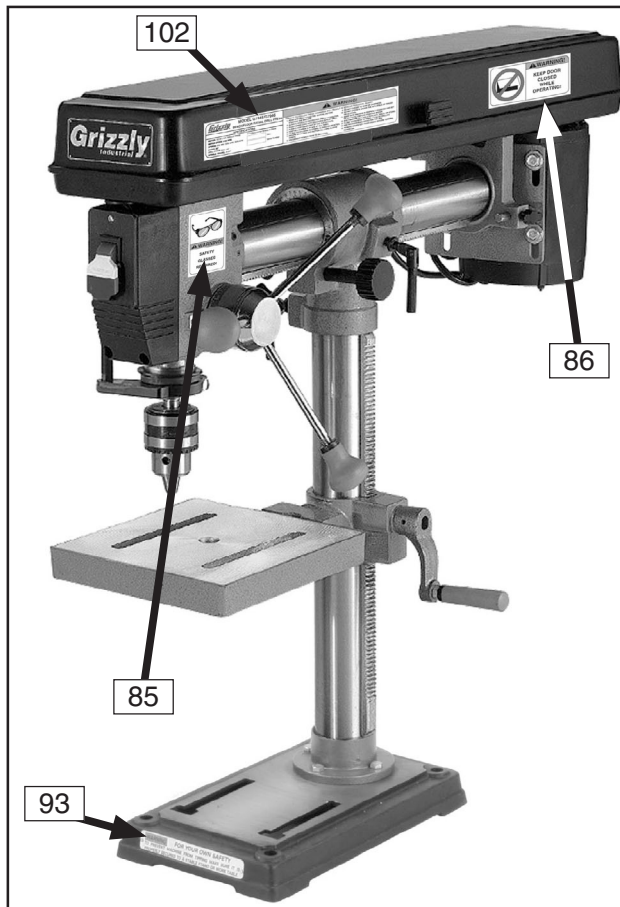

REF	PART #	DESCRIPTION
85	PLABEL-11	LABEL (SAFETY GLASSES)
86	P7945086	LABEL (DOOR CLOSED-HORIZ)
93	P7945093	LABEL (TIPPING WARNING)
102	P7945102	MACHINE ID LABEL (G7945)
102	P7946102	MACHINE ID LABEL (G7946)
116	PLABEL-14	LABEL (ELECTRICITY)





WARRANTY CARD

Name _____

Street _____

City _____ State _____ Zip _____

Phone # _____ Email _____ Invoice # _____

Model # _____ Order # _____ Serial # _____

*The following information is given on a voluntary basis. It will be used for marketing purposes to help us develop better products and services. **Of course, all information is strictly confidential.***

1. How did you learn about us?

- Advertisement
- Card Deck
- Friend
- Website
- Catalog
- Other:

2. Which of the following magazines do you subscribe to?

- | | | |
|---|--|---|
| <input type="checkbox"/> Cabinet Maker | <input type="checkbox"/> Popular Mechanics | <input type="checkbox"/> Today's Homeowner |
| <input type="checkbox"/> Family Handyman | <input type="checkbox"/> Popular Science | <input type="checkbox"/> Wood |
| <input type="checkbox"/> Hand Loader | <input type="checkbox"/> Popular Woodworking | <input type="checkbox"/> Wooden Boat |
| <input type="checkbox"/> Handy | <input type="checkbox"/> Practical Homeowner | <input type="checkbox"/> Woodshop News |
| <input type="checkbox"/> Home Shop Machinist | <input type="checkbox"/> Precision Shooter | <input type="checkbox"/> Woodsmith |
| <input type="checkbox"/> Journal of Light Cont. | <input type="checkbox"/> Projects in Metal | <input type="checkbox"/> Woodwork |
| <input type="checkbox"/> Live Steam | <input type="checkbox"/> RC Modeler | <input type="checkbox"/> Woodworker West |
| <input type="checkbox"/> Model Airplane News | <input type="checkbox"/> Rifle | <input type="checkbox"/> Woodworker's Journal |
| <input type="checkbox"/> Modeltec | <input type="checkbox"/> Shop Notes | <input type="checkbox"/> Other: |
| <input type="checkbox"/> Old House Journal | <input type="checkbox"/> Shotgun News | |

3. What is your annual household income?

- \$20,000-\$29,000
- \$30,000-\$39,000
- \$40,000-\$49,000
- \$50,000-\$59,000
- \$60,000-\$69,000
- \$70,000+

4. What is your age group?

- 20-29
- 30-39
- 40-49
- 50-59
- 60-69
- 70+

5. How long have you been a woodworker/metalworker?

- 0-2 Years
- 2-8 Years
- 8-20 Years
- 20+ Years

6. How many of your machines or tools are Grizzly?

- 0-2
- 3-5
- 6-9
- 10+

7. Do you think your machine represents a good value? Yes No

8. Would you recommend Grizzly Industrial to a friend? Yes No

9. Would you allow us to use your name as a reference for Grizzly customers in your area?
Note: We never use names more than 3 times. Yes No

10. Comments: _____

CUT ALONG DOTTED LINE

FOLD ALONG DOTTED LINE



Place
Stamp
Here



GRIZZLY INDUSTRIAL, INC.
P.O. BOX 2069
BELLINGHAM, WA 98227-2069



FOLD ALONG DOTTED LINE

Send a Grizzly Catalog to a friend:

Name _____
Street _____
City _____ State _____ Zip _____

TAPE ALONG EDGES--PLEASE DO NOT STAPLE

WARRANTY AND RETURNS

Grizzly Industrial, Inc. warrants every product it sells for a period of **1 year** to the original purchaser from the date of purchase. This warranty does not apply to defects due directly or indirectly to misuse, abuse, negligence, accidents, repairs or alterations or lack of maintenance. This is Grizzly's sole written warranty and any and all warranties that may be implied by law, including any merchantability or fitness, for any particular purpose, are hereby limited to the duration of this written warranty. We do not warrant or represent that the merchandise complies with the provisions of any law or acts unless the manufacturer so warrants. In no event shall Grizzly's liability under this warranty exceed the purchase price paid for the product and any legal actions brought against Grizzly shall be tried in the State of Washington, County of Whatcom.

We shall in no event be liable for death, injuries to persons or property or for incidental, contingent, special, or consequential damages arising from the use of our products.

To take advantage of this warranty, contact us by mail or phone and give us all the details. We will then issue you a "Return Number," which must be clearly posted on the outside as well as the inside of the carton. We will not accept any item back without this number. Proof of purchase must accompany the merchandise.

The manufacturers reserve the right to change specifications at any time because they constantly strive to achieve better quality equipment. We make every effort to ensure that our products meet high quality and durability standards and we hope you never need to use this warranty.

Please feel free to write or call us if you have any questions about the machine or the manual.

Thank you again for your business and continued support. We hope to serve you again soon.

grizzly.com[®]

TOOL WEBSITE

Buy Direct and Save with Grizzly[®] – Trusted, Proven and a Great Value!
~Since 1983~

*Visit Our Website Today For
Current Specials!*

**ORDER
24 HOURS A DAY!
1-800-523-4777**



Free Manuals Download Website

<http://myh66.com>

<http://usermanuals.us>

<http://www.somanuals.com>

<http://www.4manuals.cc>

<http://www.manual-lib.com>

<http://www.404manual.com>

<http://www.luxmanual.com>

<http://aubethermostatmanual.com>

Golf course search by state

<http://golfingnear.com>

Email search by domain

<http://emailbydomain.com>

Auto manuals search

<http://auto.somanuals.com>

TV manuals search

<http://tv.somanuals.com>