

Grizzly **Industrial, Inc.**®

MODEL G0548Z/G0548ZP G1028Z2/G1029Z2/G1029Z2P DUST COLLECTOR

OWNER'S MANUAL

(For models manufactured since 9/11)



G0548Z



G1028Z2/G1029Z2



COPYRIGHT © FEBRUARY, 2012 BY GRIZZLY INDUSTRIAL, INC. REVISED APRIL, 2012 (BL)

**WARNING: NO PORTION OF THIS MANUAL MAY BE REPRODUCED IN ANY SHAPE
OR FORM WITHOUT THE WRITTEN APPROVAL OF GRIZZLY INDUSTRIAL, INC.**

#BL14676 PRINTED IN TAIWAN



WARNING!

This manual provides critical safety instructions on the proper setup, operation, maintenance, and service of this machine/tool. Save this document, refer to it often, and use it to instruct other operators.

Failure to read, understand and follow the instructions in this manual may result in fire or serious personal injury—including amputation, electrocution, or death.

The owner of this machine/tool is solely responsible for its safe use. This responsibility includes but is not limited to proper installation in a safe environment, personnel training and usage authorization, proper inspection and maintenance, manual availability and comprehension, application of safety devices, cutting/sanding/grinding tool integrity, and the usage of personal protective equipment.

The manufacturer will not be held liable for injury or property damage from negligence, improper training, machine modifications or misuse.



WARNING!

Some dust created by power sanding, sawing, grinding, drilling, and other construction activities contains chemicals known to the State of California to cause cancer, birth defects or other reproductive harm. Some examples of these chemicals are:

- **Lead from lead-based paints.**
- **Crystalline silica from bricks, cement and other masonry products.**
- **Arsenic and chromium from chemically-treated lumber.**

Your risk from these exposures varies, depending on how often you do this type of work. To reduce your exposure to these chemicals: Work in a well ventilated area, and work with approved safety equipment, such as those dust masks that are specially designed to filter out microscopic particles.

Table of Contents

INTRODUCTION	2	SECTION 6: ACCESSORIES	34
Manual Accuracy	2	SECTION 7: MAINTENANCE	36
Contact Info.....	2	Schedule	36
Machine Description	2	Lubrication	36
Components and Terminology.....	3	Cleaning Bags.....	36
Machine Data Sheets	4	Replacing Bags.....	37
Machine Data Sheets	4	Cleaning Canister Filter	37
SECTION 1: SAFETY	7	SECTION 8: SERVICE	38
Safety Instructions for Machinery	7	Troubleshooting	38
Additional Safety for Dust Collectors	9	SECTION 9: WIRING	40
SECTION 2: POWER SUPPLY	10	Wiring Safety Instructions	40
SECTION 3: SETUP	14	G0548Z/G0548ZP Wiring Diagram.....	41
Needed for Setup.....	14	G1028Z2 Wiring Diagram	42
Unpacking	14	G1029Z2/G1029Z2P Wiring Diagram.....	43
G0548Z/G0548ZP Inventory	15	SECTION 10: PARTS	44
G1028Z2/G1029Z2/G1029Z2P Inventory....	16	G0548Z/G0548ZP Main Breakdown.....	44
Site Considerations.....	17	H5783 Canister Filter Assembly	46
G0548Z/G0548ZP Assembly	17	G1028Z2/G1029Z2 Main Breakdown	47
G1028Z2/G1029Z2/G1029Z2P Assembly ...	20	G1029Z2P Main Breakdown.....	49
Power Connection.....	23	WARRANTY AND RETURNS	53
Test Run	24		
SECTION 4: DESIGNING THE SYSTEM	25		
General	25		
Duct Material.....	25		
System Design.....	27		
System Grounding	32		
SECTION 5: OPERATIONS	33		
General	33		
Machine Storage.....	33		

INTRODUCTION

Manual Accuracy

We are proud to offer this manual with your new machine! We've made every effort to be exact with the instructions, specifications, drawings, and photographs of the machine we used when writing this manual. However, sometimes we still make an occasional mistake.

Also, owing to our policy of continuous improvement, **your machine may not exactly match the manual**. If you find this to be the case, and the difference between the manual and machine leaves you in doubt, check our website for the latest manual update or call technical support for help.

Before calling, find the manufacture date of your machine by looking at the date stamped into the machine ID label (see below). This will help us determine if the manual version you received matches the manufacture date of your machine.

		MODEL GXXXX MACHINE NAME	
SPECIFICATIONS		WARNING!	
Motor:		<p>ing this machine: operation. s and respirator. sted/setup and suit before starting.</p> <p>4. make sure the motor has stopped and disconnect power before adjustments, maintenance, or service. 5. DO NOT expose to rain or dampness. 6. DO NOT modify this machine in any way. 7. DO NOT remove safety guards. 8. Never leave machine running unattended. 9. DO NOT operate under the influence of drugs or alcohol. 10. Maintain machine carefully to prevent accidents.</p>	
Specification:			
Specification:			
Specification:			
Weight:			
<input type="text"/>	Date		
<input type="text"/>	Serial Number		
Manufactured for Grizzly in Taiwan			
Manufacture Date of Your Machine			

For your convenience, we post all available manuals and manual updates for free on our website at www.grizzly.com. Any updates to your model of machine will be reflected in these documents as soon as they are complete.

Contact Info

We stand behind our machines. If you have any questions or need help, use the information below to contact us. Before contacting, please get the serial number and manufacture date of your machine. This will help us help you faster.

Grizzly Technical Support
1203 Lycoming Mall Circle
Muncy, PA 17756
Phone: (570) 546-9663
Email: techsupport@grizzly.com

We want your feedback on this manual. What did you like about it? Where could it be improved? Please take a few minutes to give us feedback.

Grizzly Documentation Manager
P.O. Box 2069
Bellingham, WA 98227-2069
Email: manuals@grizzly.com

Machine Description

This machine is designed to capture dust and wood chips from woodworking machines, such as table saws, jointers, and planers. The air drawn in by the dust collector is filtered before it returns to the workspace.

A wide variety of accessories for setting up a stationary or mobile dust collection system are available through Grizzly.

The G0548Z/ZP features an upper canister filter; models G1028Z2 and G1029Z2/Z2P feature an upper filter bag. Polar Bear models G0548ZP and G1029Z2P are white; the G0548Z, G1028Z2 and G1029Z2 are green.



Components and Terminology

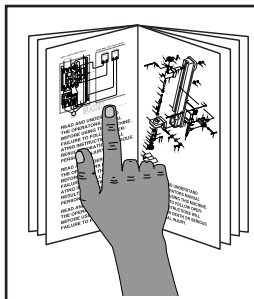
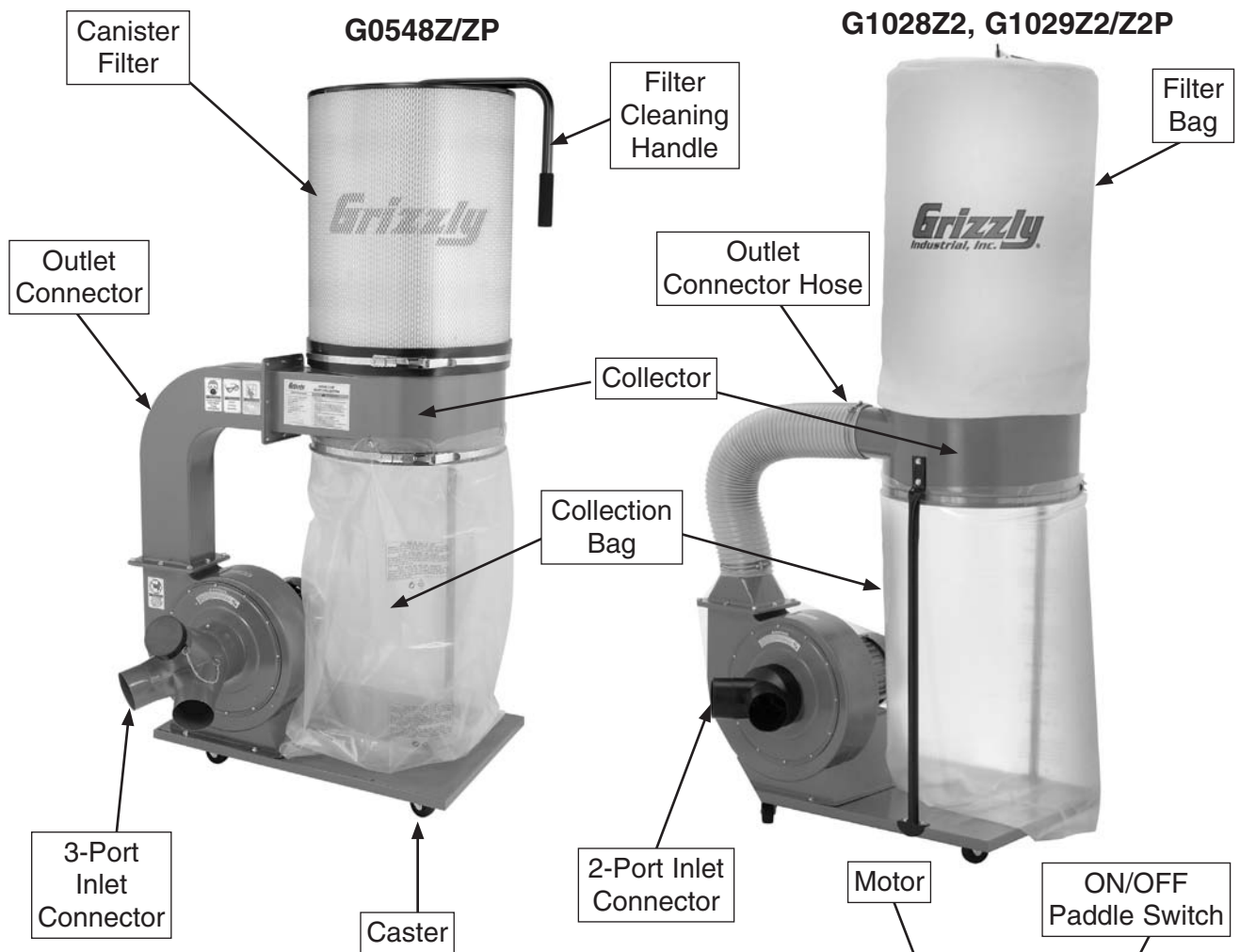

!WARNING

To reduce the risk of serious injury when using this machine, read and understand this entire manual before beginning any operations.

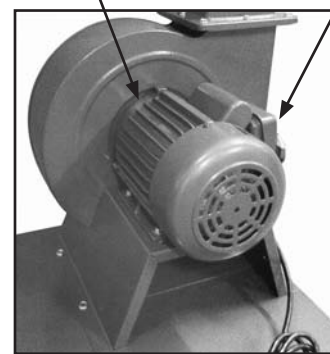

Figure 1. Rear view identification.





MACHINE DATA SHEET

© Grizzly Industrial, Inc. • Customer Service: (800) 523-4777 • Tech Support: (570) 546-9663

MODEL G0548Z, G0548ZP, G1028Z2, G1029Z2, G1029Z2P DUST COLLECTORS

Model Number	G0548Z/G0548ZP	G1028Z2	G1029Z2/G1029Z2P
Product Dimensions			
Weight	145 lbs.	95 lbs.	
Width (side-to-side)/Depth (front-to-back)/Height	37 x 27 x 71 in.	37 x 27 x 76 in.	
Foot Print (Width/Depth)	33-1/2 x 21-1/4 in.		
Shipping Dimensions			
Carton 1			
Type	Cardboard		
Content	Machine		
Weight	126 lbs.	118 lbs.	126 lbs.
Width (side-to-side)/Depth (front-to-back)/Height	36 x 23 x 23 in.	35 x 23 x 23 in.	36 x 23 x 22 in.
Carton 2			
Type	Cardboard	Not Applicable	
Content	Canister		
Weight	29 lbs.		
Width (side-to-side)/Depth (front-to-back)/Height	22 x 22 x 23 in.		
Electrical			
Power Requirement	240V, Single-Phase, 60 Hz	120V/240V, Single-Phase, 60 Hz	240V, Single-Phase, 60 Hz
Prewired Voltage	Not Applicable	120V	Not Applicable
Full-Load Current Rating	9A	12A at 120V, 6A at 240V	9A
Minimum Circuit Size	15A		
Switch	Safety Paddle Switch		
Switch Voltage	240V	120V/240V	240V
Cord Length	6 ft.		
Cord Gauge	14 AWG		
Plug Included	Yes		
Included Plug Type	NEMA 6-15	NEMA 5-15 for 120V	NEMA 6-15
Recommended Plug/Outlet Type	Not Applicable	NEMA 6-15 for 240V	Not Applicable



Model Number	G0548Z/G0548ZP	G1028Z2	G1029Z2/G1029Z2P
Main Motor			
Type	TEFC Capacitor Start Induction		
Horsepower	2 HP	1.5 HP	2 HP
Voltage	240V	120V/240V	240V
Phase	Single-Phase		
Amps	9A	12A/10A	9A
Speed	3450 RPM		
Cycle	60 Hz		
Power Transfer	Direct Drive		
Bearings	Shielded & Permanently Lubricated		
Operation Information			
Type	Canister	Bag	
Air Suction Capacity	1700 CFM	1300 CFM	1550 CFM
Maximum Static Pressure	10 in.	9 in.	11 in.
Main Inlet Size	6 in.		
Manifold Included	Yes		
Manifold Inlets	3	2	
Manifold Inlet Size	4 in.		
Maximum Material Collection Capacity	4.5 cu. ft.	5.7 cu. ft.	
Canister or Upper Bag Filtration	1 micron	2.5 micron	

Bag Information			
Number of Upper Bags	Not Applicable	1	
Upper Bag Capacity	Not Applicable	5.7 cu. ft.	
Upper Bags Total Area	Not Applicable	5.7 cu. ft.	
Upper Bag Diameter	Not Applicable	19-1/2 in.	
Upper Bag Length	Not Applicable	33 in.	
Number of Lower Bags	1		
Lower Bag Capacity	5.7 cu. ft.		
Lower Bags Total Area	5.7 cu. ft.		
Lower Bag Diameter	19-1/2 in.		
Lower Bag Length	33 in.		
Impeller Information			
Impeller Type	Radial Fin		
Impeller Size	12-3/4 in.		
Impeller Blade Thickness	1/8 in.		



Model Number	G0548Z/G0548ZP	G1028Z2	G1029Z2/G1029Z2P
Construction			
Upper Bag	Not Applicable	Fabric	
Lower Bag	Clear Plastic		
Canister	Spun Bond Polyester	Not Applicable	
Base	Fabricated Sheet Metal with Casters		
Frame	Fabricated Sheet Metal	Formed Steel	
Caster	High Density Plastic		
Impeller	Cast Aluminum		
Paint	Powder Coated		
Other			
Height with Bags Inflated	71 in.	78 in.	
Country of Origin	Taiwan		
Warranty	1 Year		
Serial Number Location	On ID Label		
Assembly Time	45 Minutes		
Awards	Wood Magazine Top Value 1997, Popular Woodworking Editor's Choice, Popular Woodworking Readers' Choice		



SECTION 1: SAFETY

WARNING

For Your Own Safety, Read Instruction Manual Before Operating this Machine

The purpose of safety symbols is to attract your attention to possible hazardous conditions. This manual uses a series of symbols and signal words intended to convey the level of importance of the safety messages. The progression of symbols is described below. Remember that safety messages by themselves do not eliminate danger and are not a substitute for proper accident prevention measures.



Indicates an imminently hazardous situation which, if not avoided, **WILL** result in death or serious injury.



Indicates a potentially hazardous situation which, if not avoided, **COULD** result in death or serious injury.



Indicates a potentially hazardous situation which, if not avoided, **MAY** result in minor or moderate injury. It may also be used to alert against unsafe practices.

NOTICE

This symbol is used to alert the user to useful information about proper operation of the machine.

WARNING

Safety Instructions for Machinery

OWNER'S MANUAL. Read and understand this owner's manual **BEFORE** using machine. Untrained users can be seriously hurt.

EYE PROTECTION. Always wear ANSI-approved safety glasses or a face shield when operating or observing machinery to reduce the risk of eye injury or blindness from flying particles. Everyday eyeglasses are not approved safety glasses.

HAZARDOUS DUST. Dust created while using machinery may cause cancer, birth defects, or long-term respiratory damage. Be aware of dust hazards associated with each workpiece material, and always wear a NIOSH-approved respirator to reduce your risk.

WEARING PROPER APPAREL. Do not wear clothing, apparel, or jewelry that can become entangled in moving parts. Always tie back or cover long hair. Wear non-slip footwear to avoid accidental slips which could cause a loss of workpiece control.

HEARING PROTECTION. Always wear hearing protection when operating or observing loud machinery. Extended exposure to this noise without hearing protection can cause permanent hearing loss.

MENTAL ALERTNESS. Be mentally alert when running machinery. Never operate under the influence of drugs or alcohol, when tired, or when distracted.



WARNING

DISCONNECTING POWER SUPPLY. Always disconnect machine from power supply before servicing, adjusting, or changing cutting tools (bits, blades, cutters, etc.). Make sure switch is in OFF position before reconnecting to avoid an unexpected or unintentional start.

APPROVED OPERATION. Untrained operators can be seriously hurt by machinery. Only allow trained or properly supervised people to use machine. When machine is not being used, disconnect power, remove switch keys, or lock-out machine to prevent unauthorized use—especially around children. Make workshop kid proof!

DANGEROUS ENVIRONMENTS. Do not use machinery in wet or rainy locations, cluttered areas, around flammables, or in dark areas. Keep work area clean, dry, and well-lighted.

ONLY USE AS INTENDED. Only use machine for its intended purpose. Never modify machine for a purpose not intended by the manufacturer!

USE RECOMMENDED ACCESSORIES. Consult this owner's manual or the manufacturer for recommended accessories. Using improper accessories will increase the risk of serious injury.

CHILDREN & BYSTANDERS. Keep children and bystanders a safe distance away from work area. Stop using machine if children or bystanders become a distraction.

REMOVE ADJUSTING TOOLS. Never leave adjustment tools, chuck keys, wrenches, etc. in or on machine—especially near moving parts. Verify removal before starting!

SECURING WORKPIECE. When required, use clamps or vises to secure workpiece. A secured workpiece protects hands and frees both of them to operate the machine.

FEED DIRECTION. Unless otherwise noted, feed work against the rotation of blades or cutters. Feeding in the same direction of rotation may pull your hand into the cut.

FORCING MACHINERY. Do not force machine. It will do the job safer and better at the rate for which it was designed.

GUARDS & COVERS. Guards and covers can protect you from accidental contact with moving parts or flying debris. Make sure they are properly installed, undamaged, and working correctly before using machine.

NEVER STAND ON MACHINE. Serious injury or accidental contact with cutting tool may occur if machine is tipped. Machine may be damaged.

STABLE MACHINE. Unexpected movement during operations greatly increases risk of injury or loss of control. Before starting, verify machines are stable and mobile base (if used) is locked.

AWKWARD POSITIONS. Keep proper footing and balance at all times when operating machine. Do not overreach! Avoid awkward hand positions that make workpiece control difficult or increase the risk of accidental injury.

UNATTENDED OPERATION. Never leave machine running while unattended. Turn machine **OFF** and ensure all moving parts completely stop before walking away.

MAINTAIN WITH CARE. Follow all maintenance instructions and lubrication schedules to keep machine in good working condition. An improperly maintained machine increases risk of injury.

CHECK DAMAGED PARTS. Regularly inspect machine for damaged parts, loose bolts, mis-adjusted or mis-aligned parts, binding, or any other conditions that may affect safe operation. Always repair or replace damaged or mis-adjusted parts before operating machine.

MAINTAIN POWER CORDS. When disconnecting cord-connected machines from power, grab and pull the plug—NOT the cord. Pulling the cord may damage the wires inside. Do not handle cord/plug with wet hands. Avoid cord damage by keeping it away from heated surfaces, high traffic areas, harsh chemicals, and wet/damp locations.

EXPERIENCING DIFFICULTIES. If at any time you are experiencing difficulties performing the intended operation, stop using the machine! Contact our Technical Support Department at (570) 546-9663.



Additional Safety for Dust Collectors

WARNING

INTENDED USE. This dust collector is designed for collecting wood dust and chips from wood-working machines. DO NOT use it to collect metal, dirt, drywall, asbestos, lead paint, silica, liquids, aerosols, biohazards, or explosive materials. Collecting the wrong materials can result in serious inhalation hazards, fire, or machine damage.

HAZARDOUS DUST. Dust created while using machinery may cause cancer, birth defects, or long-term respiratory damage. Be aware of dust hazards associated with each workpiece material, and always wear a NIOSH-approved respirator to reduce your risk.

WEAR A RESPIRATOR. Fine dust that is too small to be caught in the filter will be blown into the ambient air during operation. To reduce your risk of respiratory damage from this fine dust, always wear a NIOSH approved respirator during operation and for a short time after. Also, never collect dust from any type of hazardous material.

IMPELLER HAZARDS. All objects collected by this machine can strike the rotating impeller. DO NOT place hands, hair, clothing, or tools near the open inlet during operation. The powerful suction could easily pull them into the impeller, which will cause serious personal injury or damage to the machine. Always keep small animals and children away from open dust collection inlets.

DISCONNECTING POWER SUPPLY. Turn the switch **OFF**, disconnect the dust collector from the power supply, and allow the impeller to come to a complete stop before leaving the machine unattended or doing any service, cleaning, maintenance, or adjustments.

REGULAR CLEANING. Regularly check/empty the collection bags or drum to avoid the buildup of fine dust that can increase the risk of fire. Make sure to regularly clean the surrounding area where the machine is operated—excessive dust buildup on overhead lights, heaters, electrical panels, or other heat sources will increase the risk of fire.

SUSPENDED DUST PARTICLES AND IGNITION SOURCES. DO NOT operate the dust collector in areas where explosion risks are high. Areas of high risk include, but are not limited to, areas near pilot lights, open flames, or other ignition sources.

AVOIDING SPARKS. Avoid collecting steel fragments or stones. These items can produce sparks when they strike the impeller, which can smolder in wood dust for a long time before a fire is detected. If you accidentally cut into wood containing tramp metal (nails, staples, spikes, etc.), immediately turn **OFF** the dust collector, disconnect it from power, and wait for the impeller to stop—then empty the collection container into an approved airtight metal container.

OPERATING LOCATION. To reduce respiratory exposure to fine dust, locate permanently installed dust collectors away from the working area or in another room. DO NOT place the dust collector where it can be exposed to rain or moisture—exposure to water creates a shock hazard and will reduce the life of the machine.

FIRE SUPPRESSION. Only operate the dust collector in locations that contain a fire suppression system or have a fire extinguisher nearby.

STATIC ELECTRICITY. Plastic dust lines generate high amounts of static electricity as dust chips pass through them. Although rare, sparks caused by static electricity can cause explosions or fire. To reduce this risk, make sure all dust lines are thoroughly grounded by using a grounding wire.

EMPTYING DUST. When emptying dust from the collection container, wear a respirator and safety glasses. Empty dust away from ignition sources and into an approved container.

DUST ALLERGIES. Dust from certain woods will cause an allergic reaction. Always make sure you know what type of wood dust you are exposed to in the event that this happens.



SECTION 2: POWER SUPPLY

Availability

Before installing the machine, consider the availability and proximity of the required power supply circuit. If an existing circuit does not meet the requirements for this machine, a new circuit must be installed. To minimize the risk of electrocution, fire, or equipment damage, installation work and electrical wiring must be done by a qualified electrician in accordance with all applicable codes and standards.

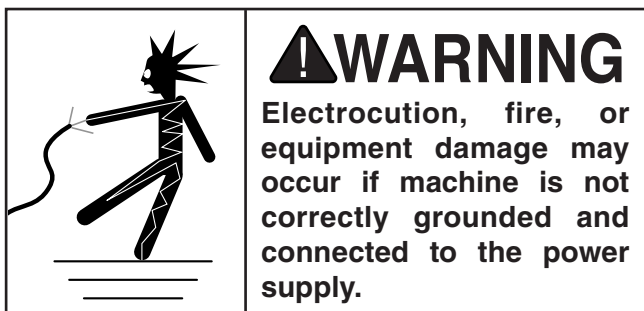

Full-Load Current Rating

The full-load current rating is the amperage a machine draws at 100% of the rated output power. On machines with multiple motors, this is the amperage drawn by the largest motor or sum of all motors and electrical devices that might operate at one time during normal operations.

- G0548Z2/G0548Z2P/G1029Z2/G1029Z2P**
Current Rating at 240V 9 Amps
- G1028Z2 Current Rating at 120V..... 12 Amps**
- G1028Z2 Current Rating at 240V 6 Amps**

The full-load current is not the maximum amount of amps that the machine will draw. If the machine is overloaded, it will draw additional amps beyond the full-load rating.

If the machine is overloaded for a sufficient length of time, damage, overheating, or fire may result—especially if connected to an undersized circuit. To reduce the risk of these hazards, avoid overloading the machine during operation and make sure it is connected to a power supply circuit that meets the requirements in the following section.

Circuit Information

A power supply circuit includes all electrical equipment between the breaker box or fuse panel in the building and the machine. The power supply circuit used for this machine must be sized to safely handle the full-load current drawn from the machine for an extended period of time. (If this machine is connected to a circuit protected by fuses, use a time delay fuse marked D.)

! CAUTION
For your own safety and protection of property, consult an electrician if you are unsure about wiring practices or electrical codes in your area.

Note: *The circuit requirements listed in this manual apply to a dedicated circuit—where only one machine will be running at a time. If this machine will be connected to a shared circuit where multiple machines will be running at the same time, consult a qualified electrician to ensure that the circuit is properly sized for safe operation.*

Grounding Requirements

This machine **MUST** be grounded. In the event of certain malfunctions or breakdowns, grounding reduces the risk of electric shock by providing a path of least resistance for electric current.

Improper connection of the equipment-grounding wire can result in a risk of electric shock. The wire with green insulation (with or without yellow stripes) is the equipment-grounding wire. If repair or replacement of the power cord or plug is necessary, do not connect the equipment-grounding wire to a live (current carrying) terminal.

Check with a qualified electrician or service personnel if you do not understand these grounding requirements, or if you are in doubt about whether the tool is properly grounded. If you ever notice that a cord or plug is damaged or worn, disconnect it from power, and immediately replace it with a new one.



⚠ WARNING

Serious injury could occur if you connect the machine to power before completing the setup process. **DO NOT** connect to power until instructed later in this manual.

Circuit Requirements for G0548Z/ G0548ZP/G1029Z2/G1029Z2P

Nominal Voltage240V
Cycle.....60 Hz
Phase..... Single-Phase
Circuit Rating..... 15 Amps
Plug/Receptacle NEMA 6-15

This machine is equipped with a power cord that has an equipment-grounding wire and a grounding plug (similar to the figure below). The plug must only be inserted into a matching receptacle (outlet) that is properly installed and grounded in accordance with all local codes and ordinances.

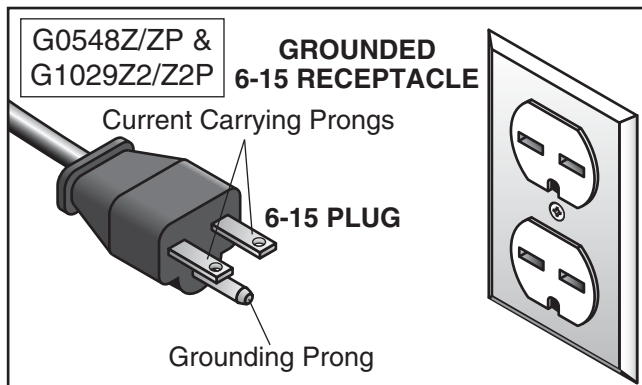
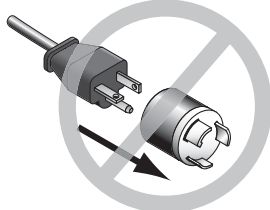

Figure 2. Typical 6-15 plug and receptacle.

⚠ CAUTION



No adapter should be used with the required plug. If the plug does not fit the available receptacle, or the machine must be reconnected for use on a different type of circuit, the reconnection must be made by a qualified electrician and comply with all local codes and ordinances.

G1028Z2 Circuit Requirements for 120V Operation (Prewired)

This machine is prewired to operate on a 120V power supply circuit that has a verified ground and meets the following requirements:

Nominal Voltage 120V
Cycle.....60 Hz
Phase..... Single-Phase
Circuit Rating..... 15 Amps
Plug/Receptacle NEMA 5-15

This machine is equipped with a power cord that has an equipment-grounding wire and a grounding plug (similar to the figure below). The plug must only be inserted into a matching receptacle (outlet) that is properly installed and grounded in accordance with all local codes and ordinances.

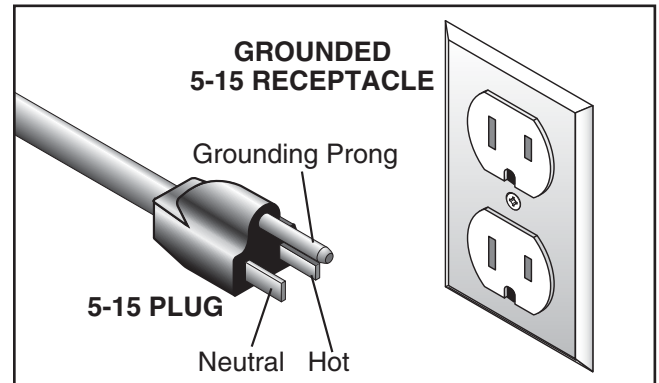
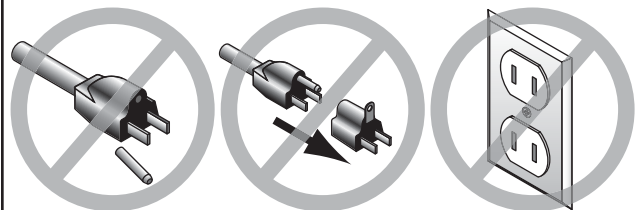

Figure 3. Typical 5-15 plug and receptacle.

⚠ CAUTION



SHOCK HAZARD!

Two-prong outlets do not meet the grounding requirements for this machine. Do not modify or use an adapter on the plug provided—if it will not fit the outlet, have a qualified electrician install the proper outlet with a verified ground.



G1028Z2 Circuit Requirements for 240V Operation

This machine can be converted to operate on a 240V power supply (refer to **Voltage Conversion** instructions) that has a verified ground and meets the following requirements:

Nominal Voltage240V
Cycle.....60 Hz
Phase..... Single-Phase
Circuit Rating..... 15 Amps
Plug/Receptacle NEMA 6-15

For 240V operation: The plug specified under “Circuit Requirements for 240V” on the previous page has a grounding prong that must be attached to the equipment-grounding wire on the included power cord. The plug must only be inserted into a matching receptacle (see following figure) that is properly installed and grounded in accordance with all local codes and ordinances.

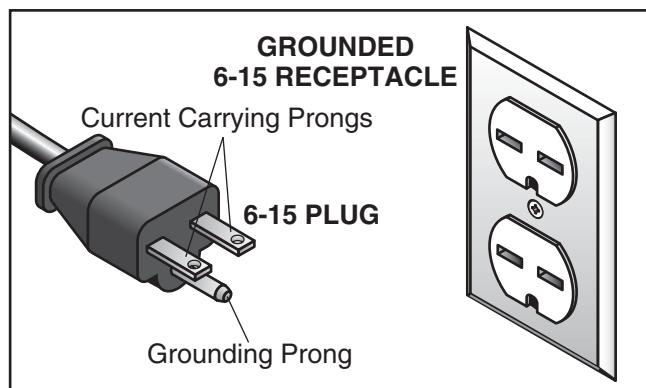

Figure 4. Typical 6-15 plug and receptacle.

Extension Cords

We do not recommend using an extension cord with this machine. If you must use an extension cord, only use it if absolutely necessary and only on a temporary basis.

Extension cords cause voltage drop, which may damage electrical components and shorten motor life. Voltage drop increases as the extension cord size gets longer and the gauge size gets smaller (higher gauge numbers indicate smaller sizes).

Any extension cord used with this machine must contain a ground wire, match the required plug and receptacle, and meet the following requirements:

Minimum Gauge Size14 AWG
Maximum Length (Shorter is Better).....50 ft.



Voltage Conversion (G1028Z2 Only)

The voltage conversion **MUST** be performed by an electrician or qualified service personnel.

The voltage conversion procedure consists of rewiring the motor and installing the correct plug. A wiring diagram is provided on **Page 42** for your reference.

IMPORTANT: If the diagram included on the motor conflicts with the one on **Page 42**, the motor may have changed since the manual was printed. Use the diagram included on the motor junction box cover instead.

Items Needed

Qty

- Phillips Head Screwdriver #2 1
- Electrical Tape As Needed
- Wire Nut (14 AWG x 3) 1
- Plug 6-15 1

To convert the Model G1028Z2 to 240V:

1. DISCONNECT MACHINE FROM POWER!
2. Cut off the included plug.
3. Open the motor junction box, then remove the wire nuts indicated in **Figure 5**.

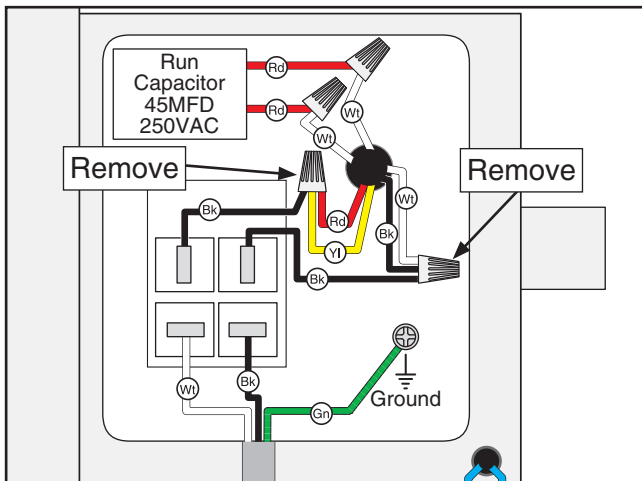

Figure 5. Location of wire nuts to be removed.

4. Connect the motor wires, as shown in **Figure 6**, with wire nuts. Once snug, wrap electrical tape around each wire nut and the connected wires, to reduce the likelihood of the wire nut vibrating loose during motor operation.

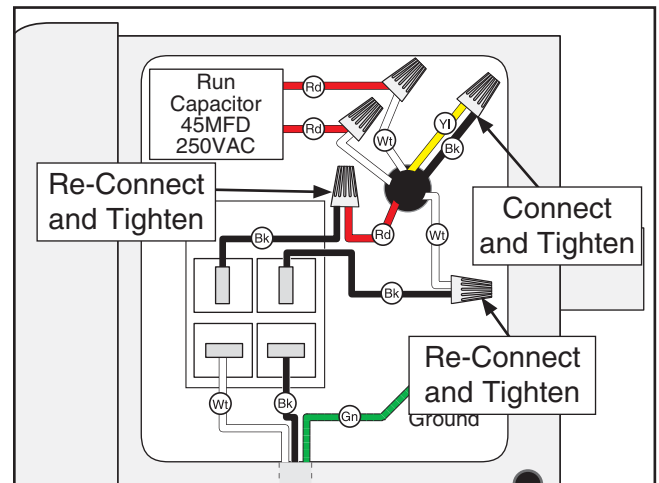
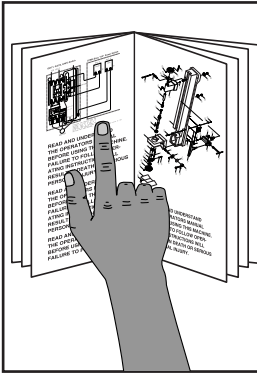

Figure 6. Motor wires repositioned for 240V.

5. Close and secure the motor junction box.
6. Install a 6-15 plug on the end of the cord, according to the instructions and wiring diagrams provided by the plug manufacturer.

—If the plug manufacturer did not include instructions, the wiring of a generic NEMA 6-15 plug is illustrated in the **Wiring** section on **Page 42**.

SECTION 3: SETUP



!WARNING

This machine presents serious injury hazards to untrained users. Read through this entire manual to become familiar with the controls and operations before starting the machine!

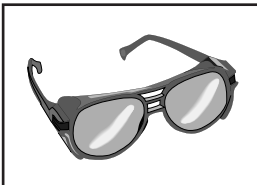

!WARNING

Wear safety glasses during the entire setup process!

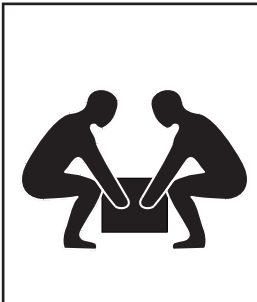

!WARNING

This machine and its components are very heavy. Get lifting help or use power lifting equipment such as a forklift to move heavy items.

Needed for Setup

The following are needed to complete the setup process, but are not included with your machine:

Description	Qty
• Additional People	1
• Safety Glasses (for each person).....	1
• Open End Wrench 12mm.....	1
• Phillips Head Screwdriver.....	1

Unpacking

Your machine was carefully packaged for safe transportation. Remove the packaging materials from around your machine and inspect it. If you discover any damage, *please call us immediately at (570) 546-9663 for advice.*

Save the containers and all packing materials for possible inspection by the carrier or its agent. *Otherwise, filing a freight claim can be difficult.*

When you are completely satisfied with the condition of your shipment, inventory the contents.



!WARNING

SUFFOCATION HAZARD!

Keep children and pets away from plastic bags or packing materials shipped with this machine. Discard immediately.



G0548Z/G0548ZP Inventory

The following is a description of the main components shipped with your machine. Lay the components out to inventory them.

If any non-proprietary parts are missing (e.g. a nut or a washer), we will gladly replace them; or for the sake of expediency, replacements can be obtained at your local hardware store.

Box 1: (Figure 7)	Qty
A. Motor & Impeller Assembly	1
B. Collector	1
C. Base	1
D. Inlet Connector 6" w/Three 4" Ports	1
E. Rubber Gaskets	2
F. Collection Bag & Clamp	
—Collection Bag Clamp	1
—Collection Bags	2
G. Canister Support	1
H. Hardware Bag	
—Casters	4
—Flange Bolts $\frac{5}{16}$ "-18 x $\frac{1}{2}$ "	40
—Tap Screw #10 x $\frac{3}{8}$ "	1
—Combo Wrench 10/12mm	1
—Hex Wrench 4mm	1
I. Outlet Connector	1

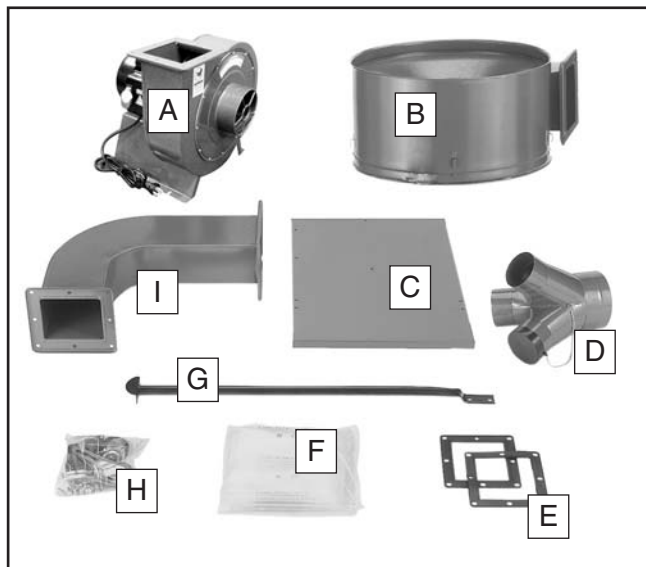

Figure 7. Model G0548Z box 1 inventory.

Box 2: (Figure 8)	Qty
J. Canister Filter	1
K. Foam Adhesive Bag	1
—Wide Foam Strip 5 x 42mm	1
—Narrow Foam Strip 6 x 20mm	1
L. Canister Belt Clamp	1
M. Canister Cleaning Handle	1



Figure 8. Model G0548Z box 2 inventory.

NOTICE

If you cannot find an item on this list, carefully check the machine and the packaging materials. Some of these items may be pre-installed for shipping or become misplaced during unpacking.

G1028Z2/G1029Z2/ G1029Z2P Inventory

The following is a description of the main components shipped with your machine. Lay the components out to inventory them.

If any non-proprietary parts are missing (e.g. a nut or a washer), we will gladly replace them; or for the sake of expediency, replacements can be obtained at your local hardware store.

Box Components:	Qty
A. Motor & Impeller Assembly	1
B. Collector Body Assembly	1
C. Y-Inlet	1
D. Base	1
E. Outlet Flange.....	1
F. Rubber Gasket	1
G. Flex Hose	1
H. Hose Clamps.....	2
I. Casters	4
J. Foam Strips	2
K. Bag Clamps.....	2
L. Lower Support Brackets	2
M. Upper Support Bracket.....	1
N. Lower Bag (Plastic)	1
O. Upper Bag (Fabric).....	1

Not Shown:	Qty
Flange Bolts $\frac{5}{16}$ "-18 x $\frac{1}{2}$ "	36

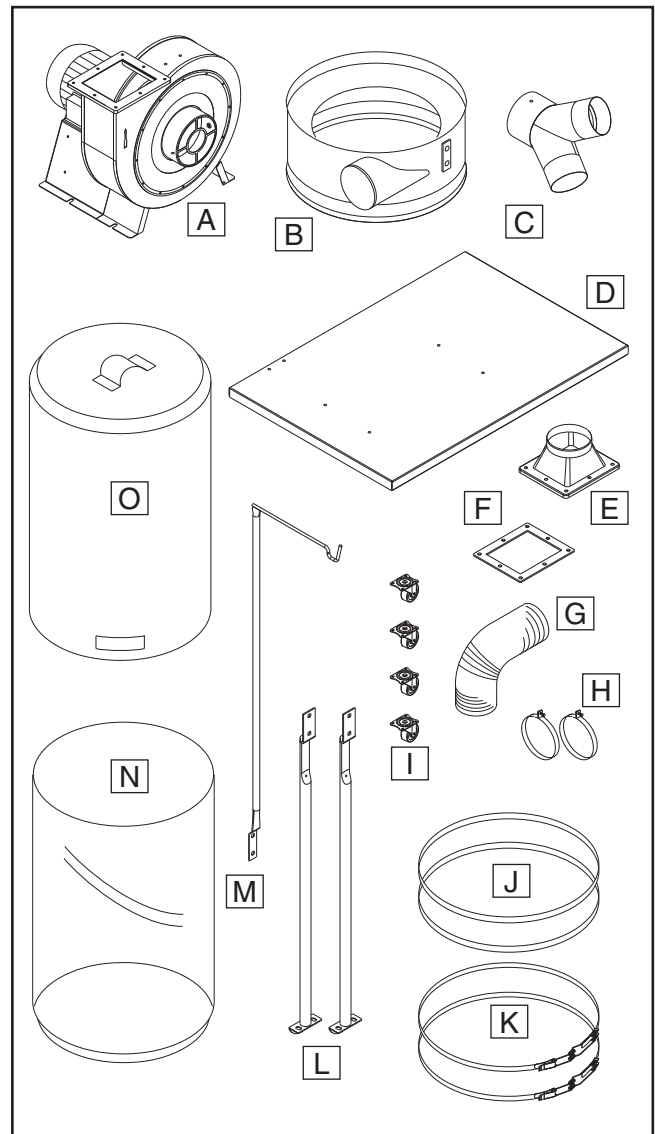

Figure 9. G1028Z2/G1029Z2/G1029Z2P inventory.

NOTICE

If you cannot find an item on this list, carefully check the machine and the packaging materials. Some of these items may be pre-installed for shipping or become misplaced during unpacking.



Site Considerations

Floor Load

Refer to the **Machine Data Sheet** for the weight and footprint specifications of your machine. Some residential floors may require additional reinforcement to support both the machine and operator.

Placement Location

Consider existing and anticipated needs, size of material to be processed through each machine, and space for auxiliary stands, work tables or other machinery when establishing a location for your new machine. See **Figure 10** for the minimum working clearances.

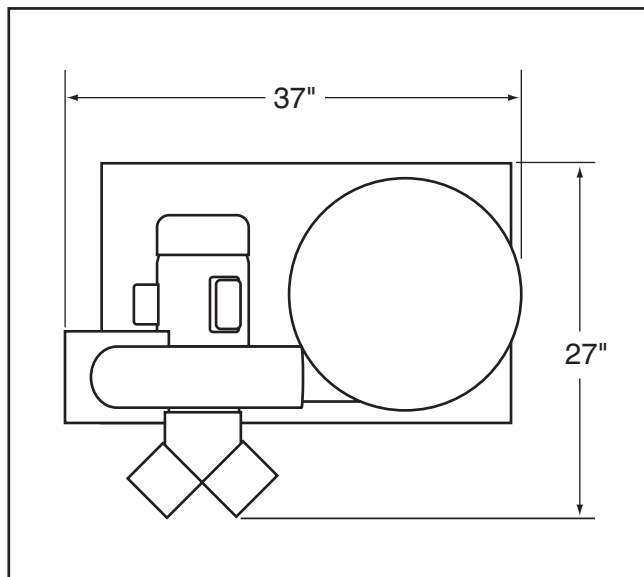
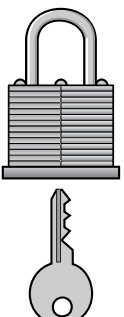

Figure 10. Minimum working clearances.

	<p>⚠ CAUTION</p> <p>Children and visitors may be seriously injured if unsupervised around this machine. Lock entrances to the shop or disable start switch or power connection to prevent unsupervised use.</p>
---	--

G0548Z/G0548ZP Assembly

To assemble your dust collector:

1. Place the base upside down on a flat, protected surface.
2. Attach the casters to the base with (16) $\frac{5}{16}$ -18 x $\frac{1}{2}$ " flange bolts, as shown in **Figure 11**.

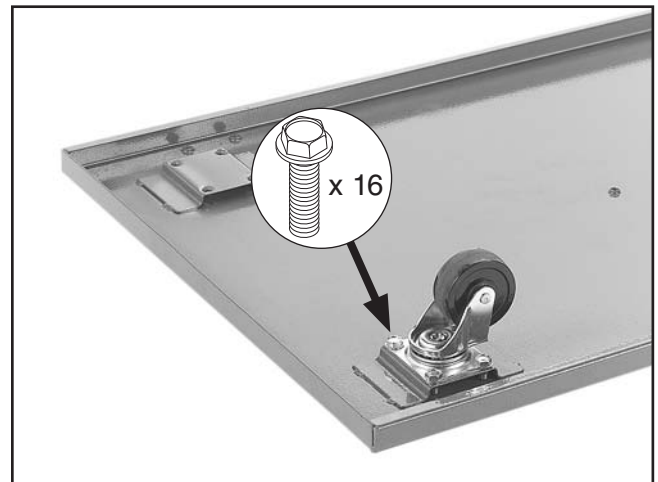

Figure 11. Caster installed on base.

3. Turn the base over, align the motor and impeller assembly with the mounting holes, then secure the assembly with (4) $\frac{5}{16}$ -18 x $\frac{1}{2}$ " flange bolts, as shown in **Figure 12**.

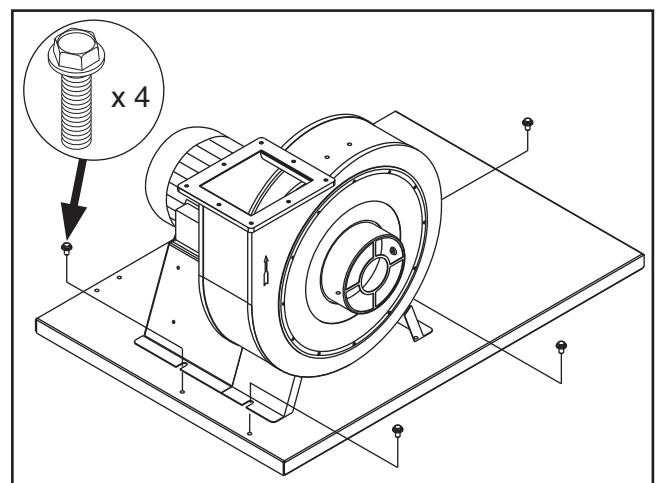

Figure 12. Motor and impeller assembly installed onto the base.

- Place a rubber gasket around the impeller outlet rim, as shown in **Figure 13**.



Figure 13. Positioning impeller outlet gasket.

- Secure the outlet connector to the impeller outlet with (8) $\frac{5}{16}$ -18 x $\frac{1}{2}$ " flange bolts, as shown in **Figure 14**.

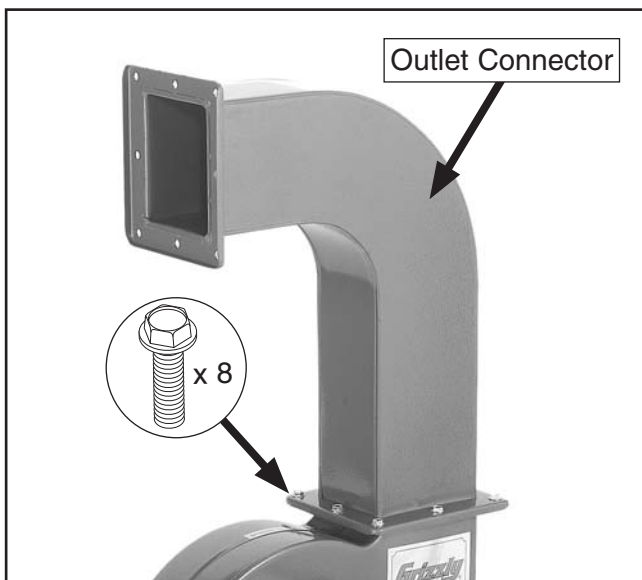

Figure 14. Outlet connector installed.

- Align the canister support with the mounting holes on the base, as shown in **Figure 15**, then secure it in place with (2) $\frac{5}{16}$ -18 x $\frac{1}{2}$ " flange bolts.

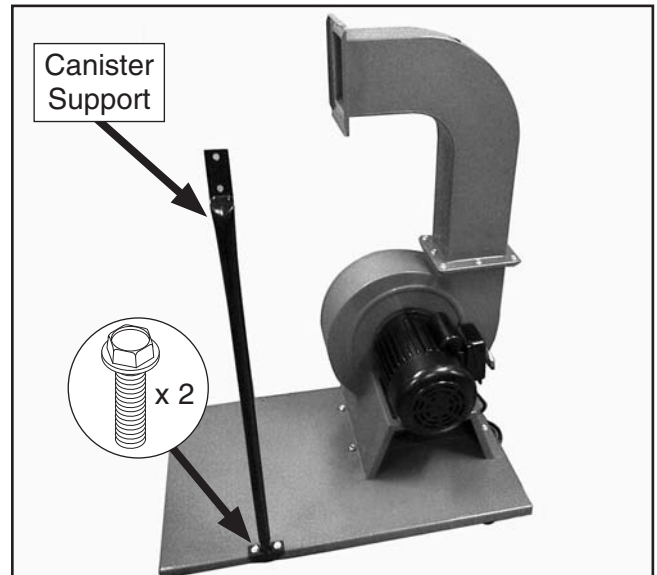

Figure 15. Canister support installed.

- With the help of another person, position the remaining rubber gasket on the rim of the outlet connector, mate the rim of the collector with the connector, and secure it in place with (8) $\frac{5}{16}$ -18 x $\frac{1}{2}$ " flange bolts, as shown in **Figure 16**.

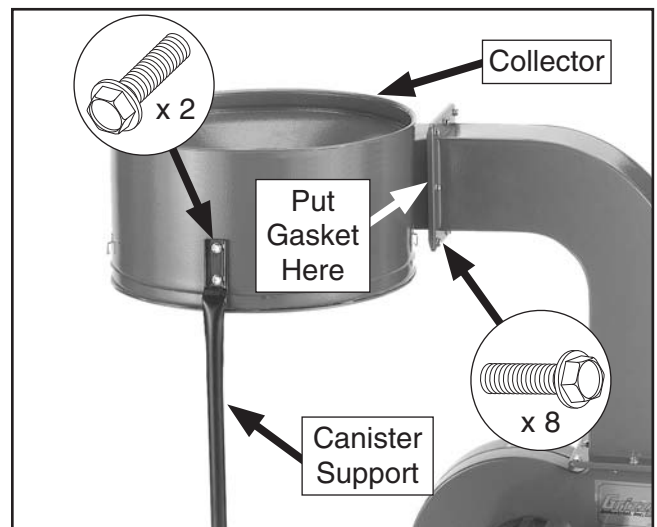

Figure 16. Collector installed.

- Attach the top of the canister support to the collector with the remaining two $\frac{5}{16}$ -18 x $\frac{1}{2}$ " flange bolts, as shown in **Figure 16**.

9. Apply the 5 x 42mm wide foam strip to the outside top of the collector, as shown in **Figure 17**, and trim the excess so that the ends of the strip come together evenly, as shown in **Figure 18**.



Figure 17. Applying the wide foam strip to the collector.



Figure 18. Wide foam strip ends matched evenly.

10. Place the cleaning handle on the canister shaft, align the hex bolt with the flat portion of the shaft and tighten the bolt, as shown in **Figure 19**.

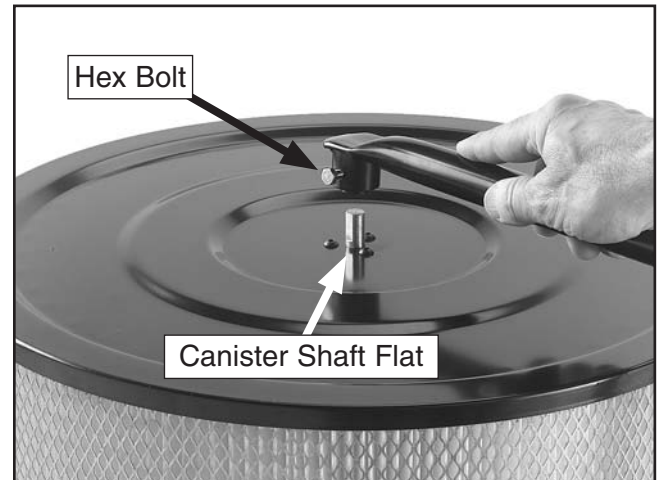

Figure 19. Installing the canister cleaning handle.

11. Position the belt clamp around the base of the canister, place the canister over the collector (as shown in **Figure 20**), then tighten the belt clamp so it evenly compresses against the wide foam strip.

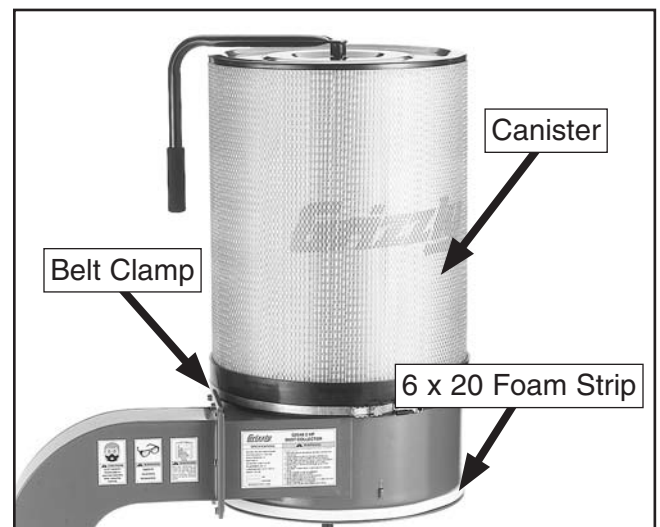

Figure 20. Canister installed.

- Apply the 6 x 20mm foam strip to the bottom of the collector, then trim the excess and evenly match the ends (see **Figure 20**).
- Attach a collection bag to the hooks around the bottom of the collector, then tighten the collection bag clamp around the foam strip to hold the bag in place, as shown in **Figure 21**.



Figure 21. Collection bag installed.

- Insert the inlet connector over the impeller intake hole, then secure it in place with the #10 x 3/8" tap screw, as shown in **Figure 22**.

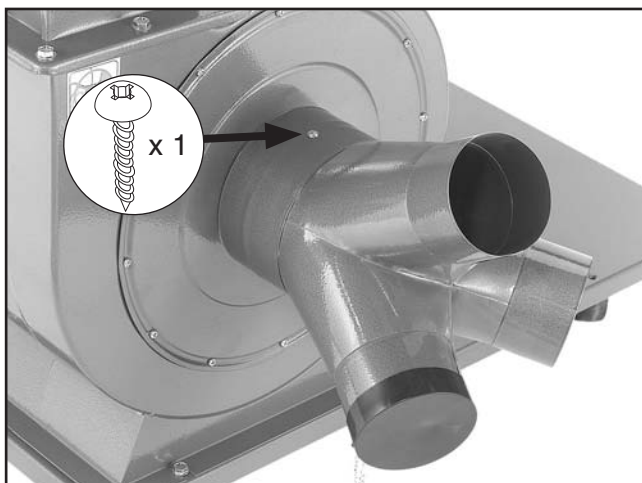

Figure 22. Inlet connector installed.

G1028Z2/G1029Z2/ G1029Z2P Assembly

To assemble your machine:

- Mount the casters to the base plate using (16) 5/16"-18 x 1/2" flange bolts, as shown in **Figure 23**.

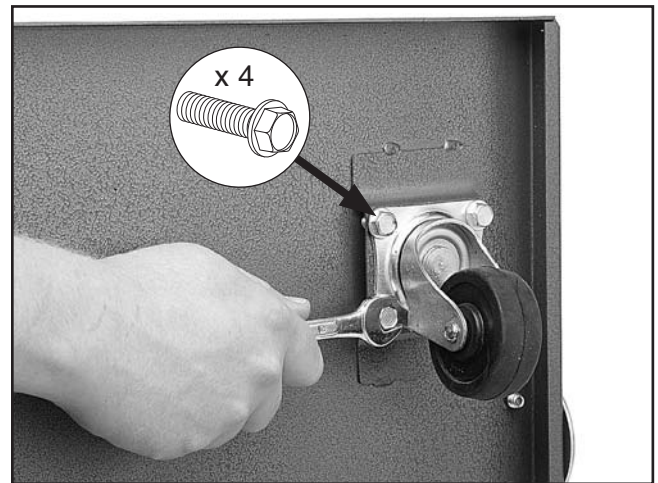

Figure 23. Mounting casters to base.

- Set the collector body on top of the base plate so the intake portion is near the edge of the base plate and the bolt holes are aligned, as shown in **Figure 24**. Secure the collector body to the base plate with (4) 5/16"-18 x 1/2" flange bolts.

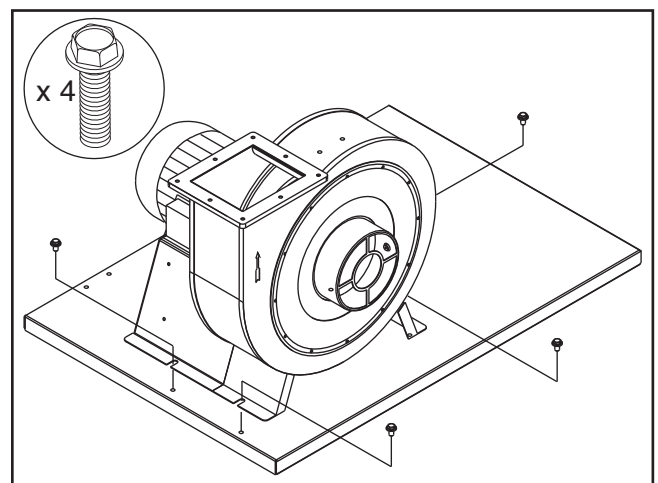

Figure 24. Mounting collector to base.

3. Insert the rubber gasket between the collector and outlet flange, and secure the flange with (8) $\frac{5}{16}$ "-18 x $\frac{1}{2}$ " flange bolts, as shown in **Figure 25**.

Note: When connecting parts that have a gasket applied to the mounting surface, always tighten the fasteners in a crisscross manner to ensure the gasket does not become crimped and the seal compromised.

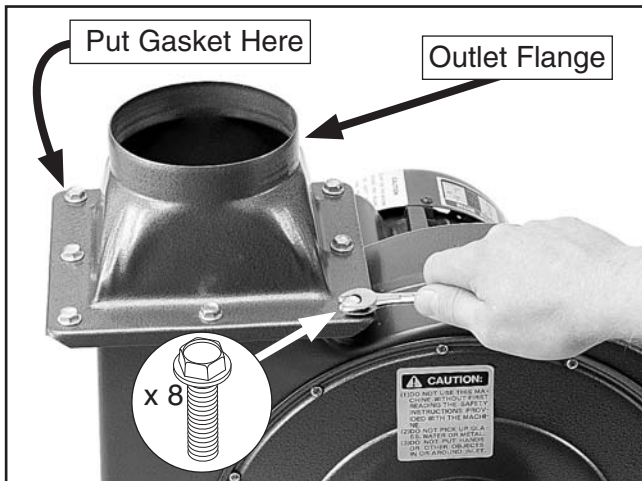

Figure 25. Mounting outlet flange to collector body.

4. Attach the lower collector support brackets to the top edge of the base plate using (4) $\frac{5}{16}$ "-18 x $\frac{1}{2}$ " flange bolts, as shown in **Figure 26**.

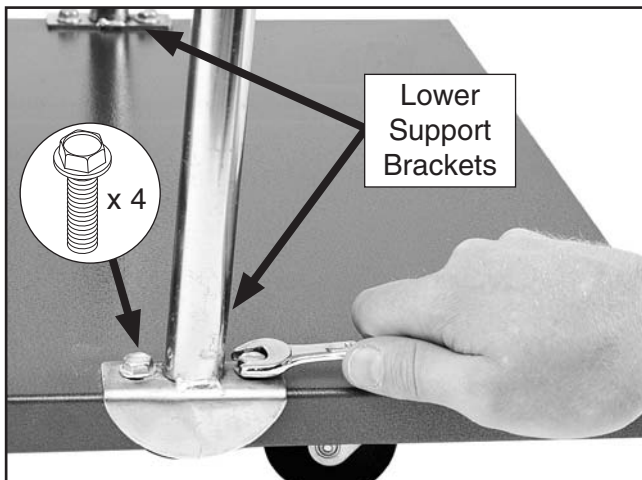

Figure 26. Mounting support bracket to base.

5. Secure the front lower support bracket to the collector with (2) $\frac{5}{16}$ "-18 x $\frac{1}{2}$ " flange bolts.
6. Place the upper support bracket over the rear lower support bracket, and secure them to the collector with (2) $\frac{5}{16}$ "-18 x $\frac{1}{2}$ " flange bolts, as shown in **Figure 27**.

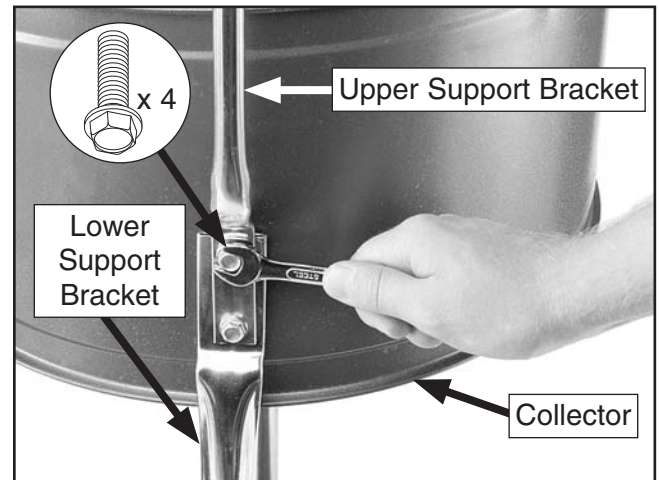

Figure 27. Mounting collector to brackets.

Note: The collector attaches to each support bracket. The inside of the collector is funnel shaped and directs the air around in a cyclone motion. Make sure that the inside taper (funnel) is faced downward and the collector inlet faces toward the motor, as shown in **Figure 28**.

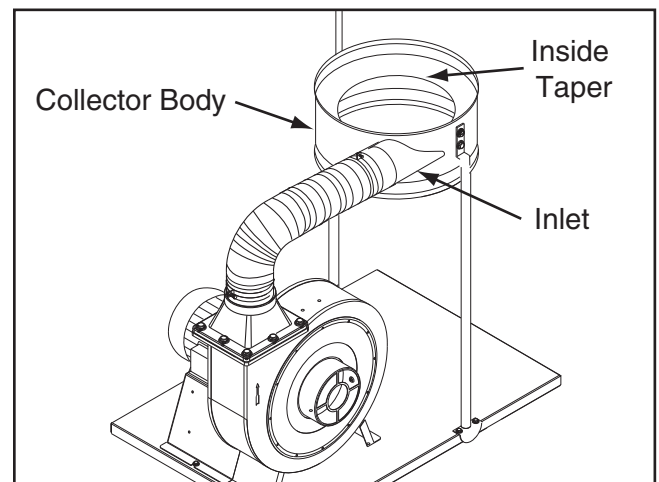

Figure 28. Collector attached to support brackets.

- Slip a loosened hose clamp over each end of the flex-hose, and position the hose ends over the outlets, as shown in **Figure 29**. Tighten each hose clamp until snug.

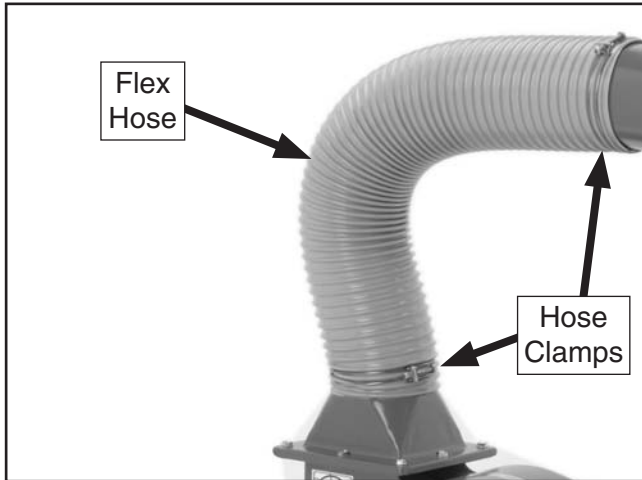

Figure 29. Attaching flex hose onto collector body outlet.

- Apply the 5 x 42mm foam strip to the outside top of the collector, as shown in **Figure 30**, and trim the excess so that the ends of the strip come together evenly, as shown in **Figure 31**.



Figure 30. Example of applying the wide foam strip to the collector.



Figure 31. Example of wide foam strip ends matched evenly.

- Hook the upper filter bag (fabric) on the support bracket, as shown in **Figure 32**.



Figure 32. Attaching upper filter bag.

- Secure the upper bag to the collector body with the clamp shown in **Figure 33**.

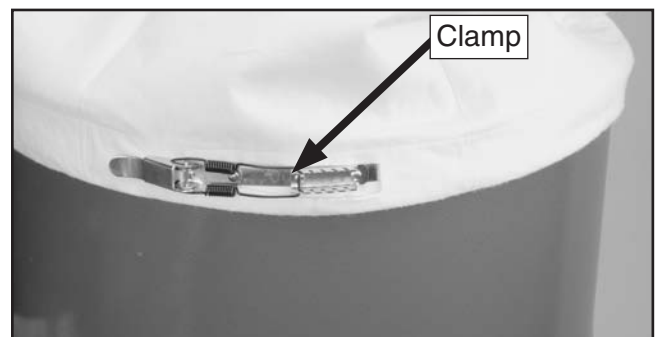

Figure 33. Upper collection bag secured.

- Apply the 6 x 20 foam strip to the bottom of the collector, then trim the excess and evenly match the ends (see **Figure 34**).



Figure 34. Example of 6 x 20 foam strip installed.

- Slip the plastic collection bag over the bottom edge of the collector, snag it on the metal hooks, and then tighten the clamp at the tightest notch possible (**Figure 35**).

Note: *DO NOT force the clamp, If it is too tight, choose the next notch over, then clamp it in place.*

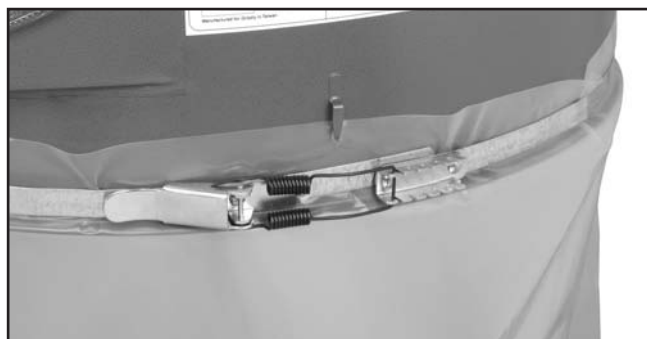

Figure 35. Installing the lower bag.

- Remove the pre-installed screw from the inlet cover, and secure the adapter to the cover flange with the screw (see **Figure 36**).

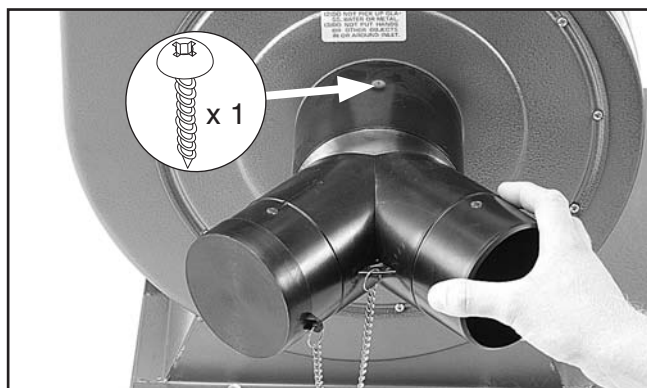

Figure 36. Installing "Y" inlet.

Power Connection

After you have completed all previous setup instructions and circuit requirements, the machine is ready to be connected to the power supply.

To prevent accidental damage to the power cord, make sure it is kept away from potential damage sources at all times—whether connected or not. Potential damage sources include high traffic areas, sharp objects, heat sources, harsh chemicals, water, damp areas, etc.

To avoid unexpected startups or property damage, use the following steps whenever connecting or disconnecting the machine.

Connecting Power

- Turn the machine power switch **OFF**.
- Insert the power cord plug into a matching power supply receptacle. The machine is now connected to the power source.

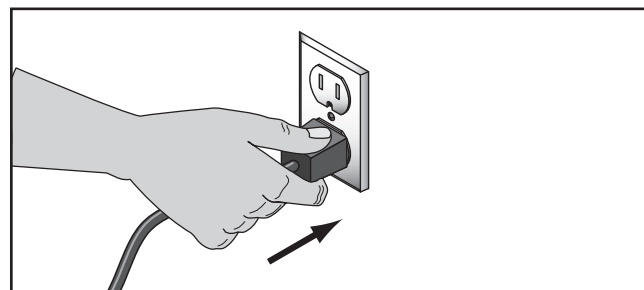

Figure 37. Connecting power.

Disconnecting Power

- Turn the machine power switch **OFF**.
- Grasp the molded plug and pull it completely out of the receptacle. Do not pull by the cord as this may damage the wires inside.

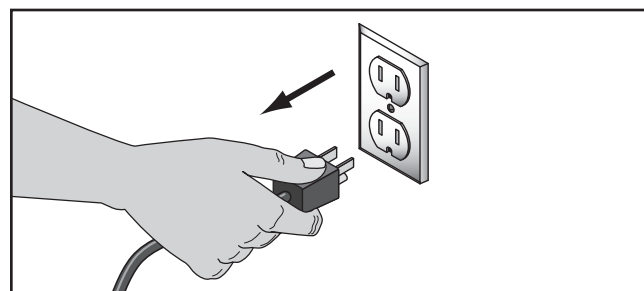

Figure 38. Disconnecting power.

Test Run

Once the assembly is complete, test run your machine to make sure it runs properly and is ready for regular operation.

The test run consists of verifying the following:
1) The motor powers up and runs correctly, and
2) the safety disabling mechanism on the switch works correctly.

If, during the test run, you cannot easily locate the source of an unusual noise or vibration, stop using the machine immediately, then review **Troubleshooting** on **Page 38**.

If you still cannot remedy a problem, contact our Tech Support at (570) 546-9663 for assistance.

To test run the machine:

1. Make sure you have read the safety instructions at the beginning of the manual and that the machine is setup properly.
2. Make sure all tools and objects used during setup are cleared away from the machine.
3. Connect the machine to power.
4. Verify that the machine is operating correctly by turning the machine **ON**.

—When operating correctly, the machine runs smoothly with little or no vibration or rubbing noises.

—Investigate and correct strange or unusual noises or vibrations before operating the machine further. Always disconnect the machine from power when investigating or correcting potential problems.

5. Turn the machine **OFF**.

6. Remove the switch disabling key, as shown in **Figure 39**.

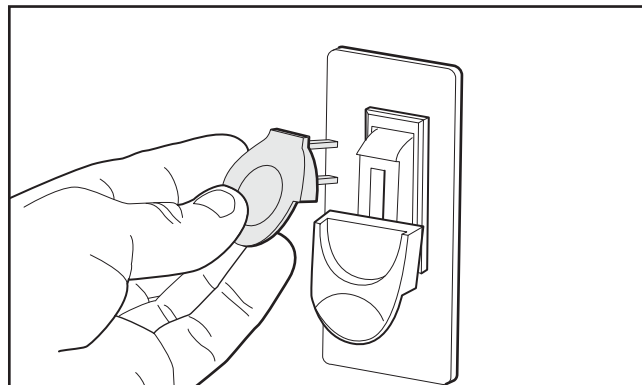

Figure 39. Removing switch key from paddle switch.

7. Try to turn the start the machine with the paddle switch.

—If the machine **DOES NOT** start, the switch disabling feature **IS** working as designed.

—If the machine **DOES** start, immediately stop the machine. The switch disabling feature **IS NOT** working correctly. This safety feature must work properly before proceeding with regular operations. Call Tech Support for help.

SECTION 4: DESIGNING THE SYSTEM

General

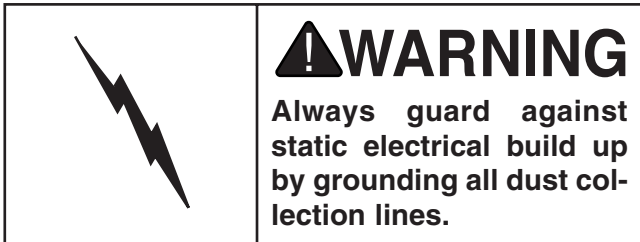

This dust collector can be operated as either a stationary, central dust collector or a mobile unit. There are advantages and disadvantages to both setups. The advantage of the mobile system is eliminating the cost of many ducts and fittings. On the other hand, the stationary system is more efficient and customizable.

If using this dust collector as a stationary system, put the dust collector in an out-of-the way location such as a corner or separate room. The dust collector is capable of collecting dust from up to two machines running simultaneously. Grizzly offers a complete line of dust collection accessories for setting up a stationary, central dust collector system. Additionally, Grizzly offers a complete guide book entitled *Dust Collection Basics*.

Whatever system you choose, always make sure there are no open flames or pilot lights in the same room as the dust collector. There is a risk of explosion if dust is dispersed into the air.

Duct Material

You have many choices regarding main line and branch line duct material. For best results, use metal duct for the main line and branch lines, then use short lengths of flexible hose to connect each machine to the branch lines.

Plastic duct is also a popular material for home shops. However, be aware that there is a fire or explosion hazard if plastic duct material is used for dust collection without being grounded against static electrical charge build-up. This topic will be discussed later in this section. Another problem with using plastic is that it is less efficient per foot than metal.

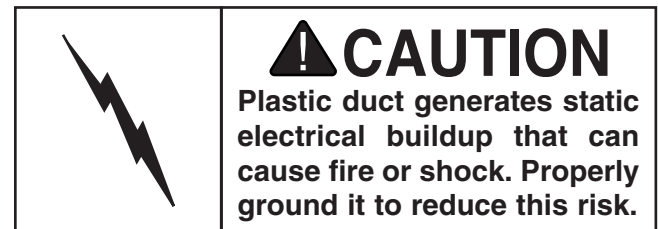

Plastic Duct

The popularity of plastic duct is due to the fact that it is an economical and readily available product. It is also simple to assemble and easily sealed against air loss. The primary disadvantage of plastic duct for dust collection is the inherent danger of static electrical build-up.



Figure 40. Examples of plastic ducting components.

Metal Duct

Advantages of metal duct is its conductivity, efficiency, and that it does not contribute to static electrical charge build-up. However, static charges are still produced when dust particles strike other dust particles as they move through the duct. Since metal duct is a conductor, it can be grounded quite easily to dissipate any static electrical charges.

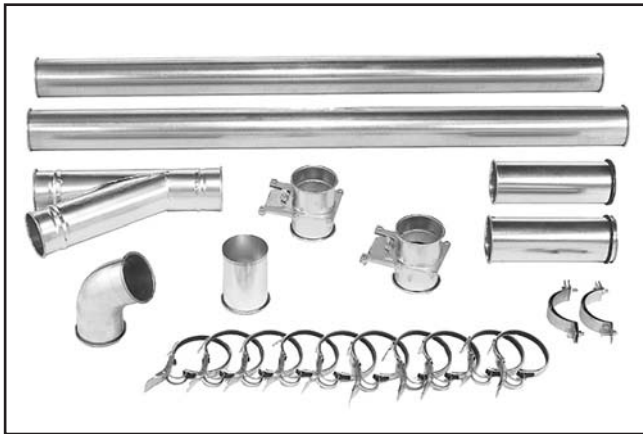

Figure 41. Examples of metal pipe and components.

There are a number of options when it comes to metal duct, but metal duct that is specially manufactured for dust collection is the best choice. When selecting your metal duct, choose high quality metal duct with smooth welded internal seams that will minimize airflow resistance. This type of duct usually connects to other ducts or elbows with a simple, self-sealing clamp, is very quick and easy to assemble, and can be readily dismantled and re-installed. This is especially important if you ever need to change things around in your shop or add more tools.

Avoid inferior metal duct that requires you to cut it to length and snap it together. This type of duct is time consuming to install because it requires you to seal all the seams with silicone and screw the components on the ends with sheet metal screws. Another disadvantage is the rough internal seams and crimped ends that unavoidably increase static pressure loss.

Flexible Duct

Flexible hose is generally used for short runs, small shops and at rigid duct-to-tool connections. There are many different types of flex hose on the market today. These are manufactured from materials such as polyethylene, PVC, cloth hose dipped in rubber and even metal, including steel and aluminum.

The superior choice here is metal flex hose that is designed to be flexible, yet be as smooth as possible to reduce static pressure loss.

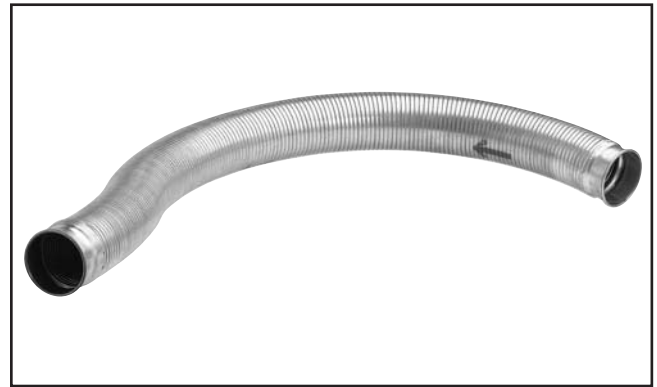

Figure 42. Example of flexible metal duct.

There are also many kinds of pure plastic flexible hose, such as non-perforated drainage type hose and dryer vent hose. Drainage type hose, while being economical, does not quite have the flexibility required for dust collection. The inside of the duct is also deeply corrugated and can increase the static pressure loss by as much as 50% over smooth wall duct. Dryer vent hose, while being completely flexible, is non-resistant to abrasion and has a tendency to collapse in a negative pressure system. We DO NOT recommend using dryer vent hose in your dust collection system.

If using flex-hose, you should choose one of the many types that are designed specifically for the movement of solid particles, i.e. dust, grains, and plastics. However, the cost of specifically designed flexible duct can vary greatly. Grizzly offers polyethylene hose, which is well suited for the removal of particulate matter, especially sawdust, since it is durable and completely flexible. Polyethylene is also very economical and available in a wide variety of diameters and lengths for most applications.

System Design

Decide Who Will Design

For most small-to-medium sized shops, you can design and build the dust collection system yourself without hiring engineers or consultants. We have included some basic information here to get you started on a basic design.

If you have a large shop or plan to design a complicated system, we recommend doing additional research beyond this manual or seeking the help of an expert.

Sketch Your Shop Layout

When designing a successful dust collection system, planning is the most important step. In this step, sketch a basic layout of your shop, including space requirements of different machines.

Before you get out your pencil and paper, we recommend you visit our **FREE Workshop Planner** available on our website at www.grizzly.com.

Our *Workshop Planner* will allow you to quickly and easily design and print a basic shop layout. Don't worry, non-Grizzly brand machines can be substituted with Grizzly machines for layout purposes. **Note:** After you're finished, make sure to save your layout for later modification.

Your sketch only needs the basic details of the shop layout, similar to the **Figure** below, including all your current/planned machines and your planned placement of the dust collector.

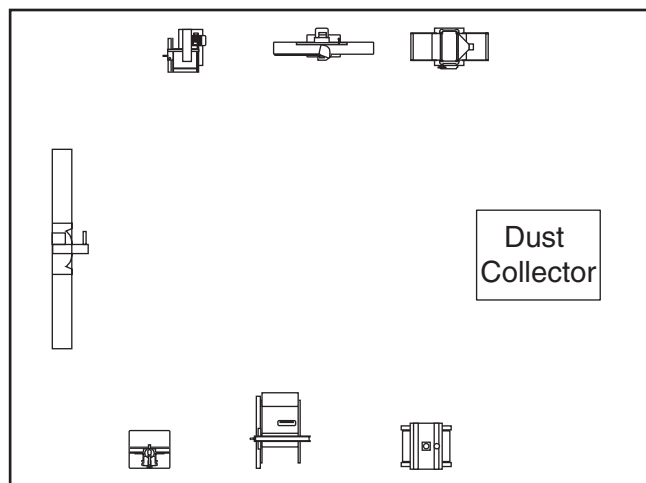

Figure 43. Basic sketch of shop layout.

Sketch a Basic Duct Layout

For the next step, sketch how you will connect your machines to the dust collector. Consider these general guidelines for an efficient system:

1. Machines that produce the most saw dust should be placed nearest to the dust collector (i.e. planers and sanders).
2. Ideally, you should design the duct system to have the shortest possible main line and secondary branch ducts. See the **Figures** below for ideas of efficient versus inefficient duct layouts.

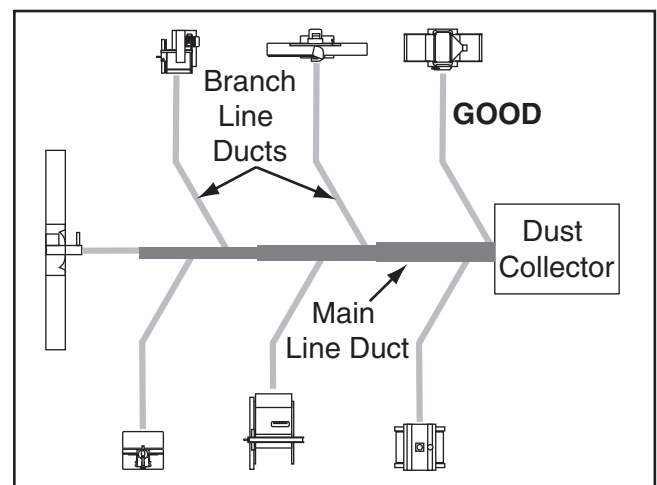

Figure 44. Efficient duct layout.

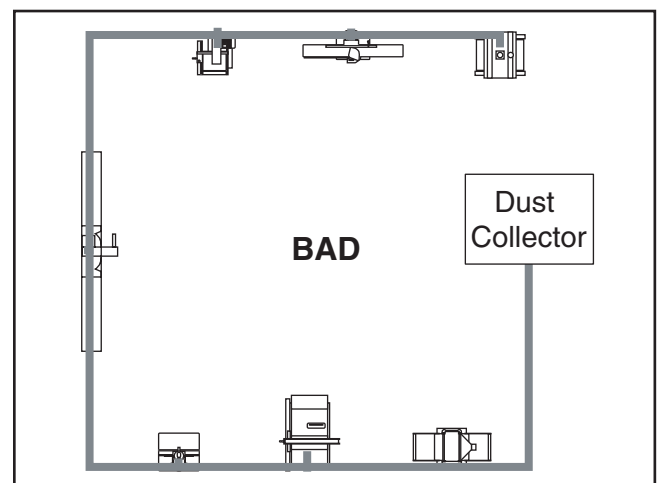

Figure 45. Inefficient duct layout.

3. Directional changes should be kept to a minimum. The more directional change fittings you use directly increases the overall resistance to airflow.
4. Gradual directional changes are more efficient than sudden directional changes (i.e. use the largest corner radius possible when changing hose or pipe direction).
5. Each individual branch line should have a blast gate immediately after the branch to control suction from one machine to another.
6. The simpler the system, the more efficient and less costly it will be.

Determine Required CFMs

Since each machine produces a different amount of sawdust, the requirements for the minimum amount of CFM to move that sawdust is unique to the machine (for example, a planer produces more sawdust than a table saw). Knowing this required CFM is important to gauging which size of duct to use.

Refer to the **Figure** below for a close estimation of the airflow each machine requires. Keep in mind that machines that generate the most sawdust should be placed closest to the dust collector. If the machine has multiple dust ports, the total CFM required is the sum of all ports.

Machine Dust Port Size	Approximate Required CFM
2"	98
2.5"	150
3"	220
4"	395
5"	614
6"	884
7"	1203
8"	1570
9"	1990
10"	2456

Figure 46. Approximate required airflow for machines, based on dust port size.

If the machine does not have a built-in dust port, use the following table to determine which size of dust port to install.

Machine	Average Dust Port Size
Table Saw.....	4"
Miter/Radial-Arm Saw.....	2"
Jointer (6" and smaller)	4"
Jointer (8"-12")	5"
Thickness Planer (13" and smaller).....	4"
Thickness Planer (14"-20")	6"
Shaper.....	4"
Router (mounted to table).....	2"
Bandsaw.....	4"
Lathe.....	4"
Disc Sander (12" and smaller).....	2"
Disc Sander (13-18").....	4"
Belt Sander (6" and smaller)	2"
Belt Sander (7"-9")	3"
Edge Sander (6" x 80" and smaller).....	4"
Edge Sander (6" x 80" and larger)	5"
Drum Sander (24" and smaller).....	2 x 4"
Drum Sander (24" and larger)	4 x 4"
Widebelt Sander (18" and smaller).....	5"
Widebelt Sander (24"-37" single head) ...	2 x 6"
Widebelt Sander (24"-51" double head) ..	5 x 4"

Figure 47. Dust port size and quantity per average machine.

Write the required CFM for each machine on your sketch, as shown in the **Figure** below.

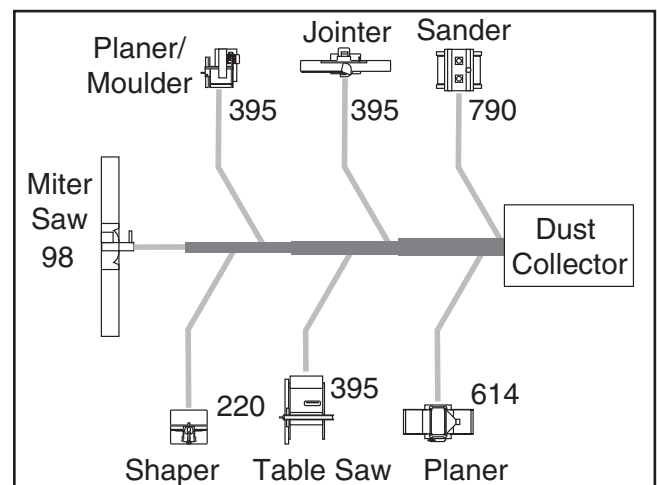

Figure 48. CFM requirements labeled for each machine.



Determining Main Line Duct Size

The general rule of thumb for a main line duct is that the velocity of the airflow must not fall below 3500 FPM.

For small/medium sized shops, using the inlet size of the dust collector as the main line duct size will usually keep the air velocity above 3500 FPM and, depending on your system, will allow you to keep multiple branches open at one time.

Mark your drawing, as shown in the **Figure** below, but using the inlet size for your dust collector as the main line.

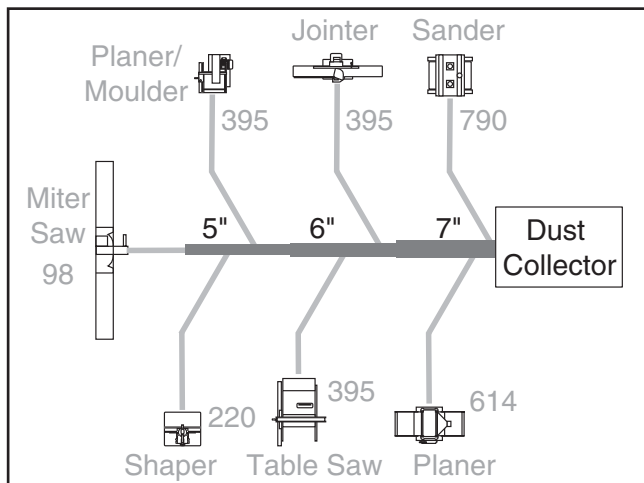

Figure 49. Main line size labeled on sketch.

Determining Branch Line Duct Size

The general rule of thumb for a branch line duct is that the velocity of the airflow must not fall below 4000 FPM.

For small/medium sized shops, using the dust port size from the machine as the branch line duct size will achieve the correct velocity in most applications. However, if the dust port on the machine is smaller than 4", make the branch line 4" and neck the line down right before the dust port.

Note: *Systems with powerful dust collectors work better if multiple blast gates are left open. This also allows you to run two machines at once. Experiment with different combinations of blast gates open/closed to find the best results for your system.*

Write your determined branch line sizes on your drawing, as shown in the following **Figure**.

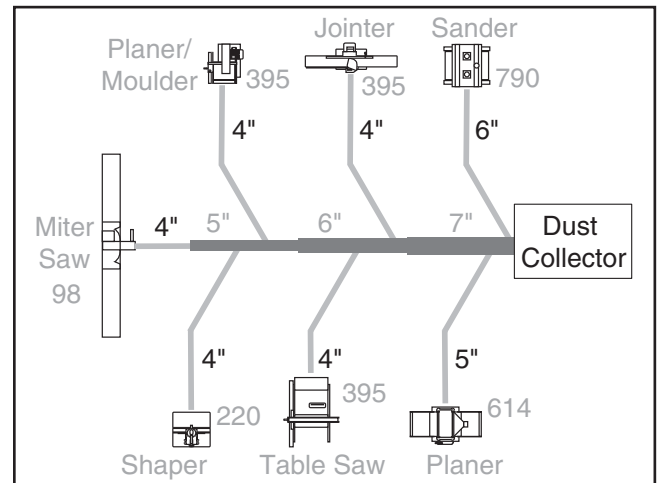

Figure 50. Branch line duct sizes labeled.

If two machines will connect to the same branch line and both will operate at the same time, then add the required CFM for each machine together and find the closest total CFM in the table below to determine the correct branch size.

If both machines will never run at the same time, reference the machine with the biggest dust port in the table below and add blast gates after the Y-branch to open/close the line to each machine.

Total CFM	Branch Line Size
400	4"
500	4"
600	5"
700	5"
800	6"
900	6"
1000	6"

Figure 51. Sizing chart for multiple machines on the same branch line.

Planning Drop Downs

Plan the drop downs for each machine, using blast gates wherever possible to control airflow.

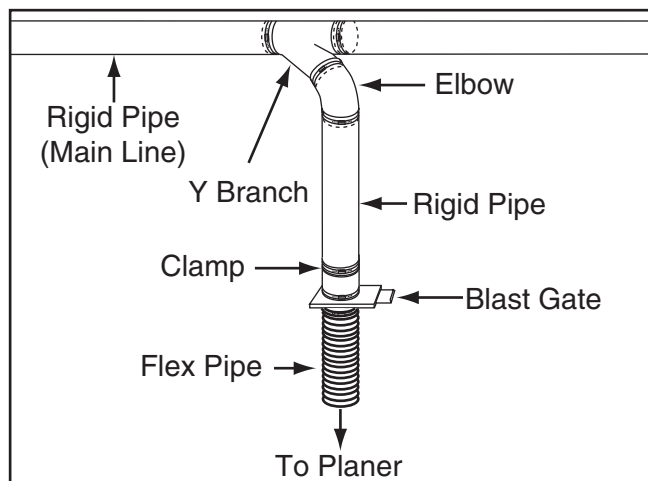

Figure 52. Drop down setup.

Calculating Duct Resistance

Adding duct work, elbows, branches and any other components to a duct line increases airflow resistance (static pressure loss). This resistance can be minimized by using rigid (smooth) pipe and gradual curves, as opposed to flexible pipe and 90° elbows.

To help you think about this resistance, imagine riding a bicycle in a tunnel that is an exact replica of your duct work. If the inside of the tunnel is very bumpy (flexible pipe) and has a lot of sharp turns (90° elbows), it will take a lot more effort to travel from one end to the other.

The purpose of calculating the resistance is to determine if it is low enough from the machine to the dust collector to meet the given CFM requirement for the machine. Use the following tables to calculate the resistance of duct work.

Duct Dia.	Approximate Static Pressure Loss Per Foot of Rigid Pipe		Approximate Static Pressure Loss Per Foot of Flex Pipe	
	Main Lines at 3500 FPM	Branch Lines at 4000 FPM	Main Lines at 3500 FPM	Branch Lines at 4000 FPM
2"	0.091	0.122	0.35	0.453
2.5"	0.08	0.107	0.306	0.397
3"	0.071	0.094	0.271	0.352
4"	0.057	0.075	0.215	0.28
5"	0.046	0.059	0.172	0.225
6"	0.037	0.047	0.136	0.18
7"	0.029	0.036	0.106	0.141
8"	0.023	0.027	0.08	0.108
9"	0.017	0.019	0.057	0.079

Fitting Dia.	90° Elbow	45° Elbow	45° Wye(Y)	90° Wye(Y)
3"	0.47	0.235	0.282	0.188
4"	0.45	0.225	0.375	0.225
5"	0.531	0.266	0.354	0.236
6"	0.564	0.282	0.329	0.235
7"	0.468	0.234	0.324	0.216
8"	0.405	0.203	0.297	0.189

Figure 53. Static pressure loss charts.

In most small/medium shops it is only necessary to calculate the line with the longest duct length or the most fittings (operating under the assumption that if the line with the highest resistance works, the others will be fine).

To calculate the static pressure of any given line in the system, follow these steps:

1. Make a list of each size duct in the line, including the length, and multiply those numbers by the static pressure value given in the previous table.
2. List each type of elbow or branch and multiply the quantity (if more than one) by the static pressure loss given in the previous table.



3. Add the additional factors from the following table to your list.

Additional Factors	Static Pressure
Seasoned (well used) Dust Collection Filter	1"
Entry Loss at Large Machine Hood	2"

Figure 54. Additional factors affecting static pressure.

4. Total your list as shown in the example below to come up with your overall static pressure loss number for that line.

Note: Always account for a seasoned filter, so you don't end up with a system that only works right when the filter is clean.

Main Line	
6" Rigid Pipe (0.037) at 20'	0.740
Branch Line	
4" Rigid Pipe (0.075) at 10'	0.750
4" Flex Pipe (0.28) at 5'	1.400
Elbows/Branches	
6" 45° Y-Branch	0.329
4" 45° Elbow	0.225
Additional Factors	
Seasoned Filter	1.000
Total Static Pressure Loss	4.444

Figure 55. Totaling static pressure numbers.

Note: When calculating static pressure loss to determine if multiple lines can be left open at the same time, only include the main line numbers once.

5. Compare the total static pressure loss for that line to the maximum static pressure loss found on the data sheet for your machine (located toward the front of this manual).

—If the CFM for your static pressure loss is above the requirement of the machine, then the line will most likely be successful. Congratulations! You've just designed your own dust system. Compile a list of materials and refer to **Accessories** to start buying the components necessary to make

—If the CFM for your static pressure loss is below the requirement of the machine, then that line will not effectively collect the dust. You must then modify some of the factors in that line to reduce the static pressure loss. Some of the ways to do this include 1) installing larger duct, 2) reducing amount of flexible duct used, 3) increasing machine dust port size, 4) moving machine closer to dust collector to eliminate duct length, and 5) reducing 90° elbows or replacing them with 45° elbows.

Compile Materials List

After the system is designed, create a materials list of all the items you will need to build your dust collection system. This will make it easy when it comes time to purchase the materials.

Below is an example of some items that might be needed. Refer to **Accessories** for dust collection components available through *grizzly.com*.

Description	Model	Quantity
6" Rigid Pipe at 20'	G7364	4
4" Rigid Pipe at 10'	G6162	2
4" Flex Hose at 5'	H7215	6
6" 45° Y-Branch	G7353	6
4" 45° Elbow	G6167	6

Figure 56. Example materials list.



System Grounding

Since plastic hose is abundant, relatively inexpensive, easily assembled and air tight, it is a very popular material for conveying dust from woodworking machines to the dust collector. We recommend using flexible hose (flex-hose) to connect the woodworking machine to the dust collector. However, plastic flex-hose and plastic duct are an insulator, and dust particles moving against the walls of the plastic duct create a static electrical build up. This charge will build until it discharges to a ground. If a grounding medium is not available to prevent static electrical build up, the electrical charge will arc to the nearest grounded source. This electrical discharge may cause an explosion and subsequent fire inside the system.

To protect against static electrical build up inside a non-conducting duct, a bare copper wire should be placed inside the duct along its length and grounded to the dust collector. You must also confirm that the dust collector is continuously grounded through the electrical circuit to the electric service panel.

If you connect the dust collector to more than one machine by way of a non-conducting branching duct system and blast gates, the system must still be grounded as mentioned above. We recommend inserting a continuous bare copper ground wire inside the entire duct system and attaching the wire to each grounded woodworking machine and dust collector.

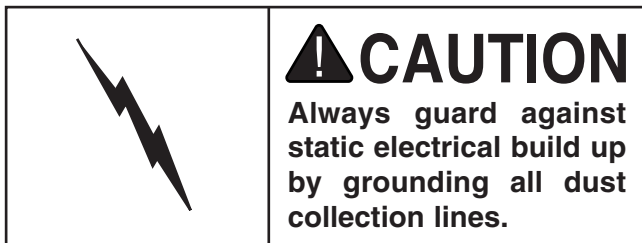

Be sure that you extend the bare copper wire down all branches of the system. Do not forget to connect the wires to each other with wire nuts when two branches meet at a “Y” or “T” connection.

Ensure that the entire system is grounded. If using plastic blast gates to direct air flow, the grounding wire must be jumped (see the **Figure** below) around the blast gate without interruption to the grounding system.

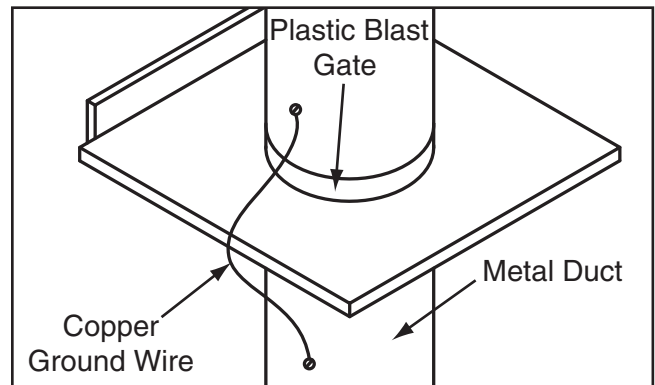

Figure 57. Ground jumper wire when using plastic blast gates and metal duct.

We also recommend wrapping the outside of all plastic ducts with bare copper wire to ground the outside of the system against static electrical build up. Wire connections at Y’s and T’s should be made with wire nuts.

Attach the bare ground wire to each stationary woodworking machine and attach to the dust collector frame with a ground screw as shown in the **Figure** below. Ensure that each machine is continuously grounded to the grounding terminal in your electric service panel.

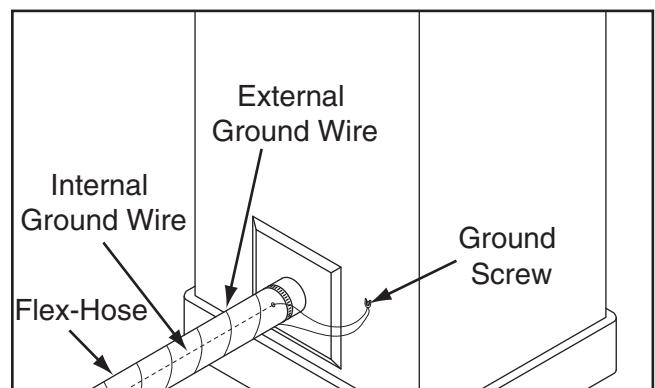
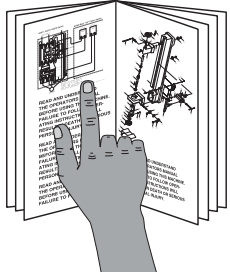

Figure 58. Flex-hose grounded to machine.





SECTION 5: OPERATIONS

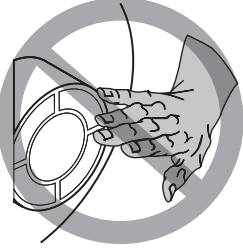

!WARNING
To reduce the risk of serious injury when using this machine, read and understand this entire manual before beginning any operations.

!WARNING
Damage to your eyes and lungs could result from using this machine without proper protective gear. Always wear safety glasses and a respirator when operating this machine.



!WARNING
Do NOT put hands or small objects near inlet openings during operation. Objects sucked into the inlet will meet with the impeller blade. Failure to heed this warning could result in property damage or personal injury.

NOTICE
If you have never used this type of machine or equipment before, WE STRONGLY RECOMMEND that you read books, trade magazines, or get formal training before beginning any projects. Regardless of the content in this section, Grizzly Industrial will not be held liable for accidents caused by lack of training.

General

Operating a dust collector is simple and straightforward. Turn the dust collector **ON**, then turn the dust producing machine **ON**. When you are finished with the machine operation, turn the machine **OFF**, then turn the dust collector **OFF**.

Blast gates can be used at the start of each branch line to control the air flow from the woodworking machine to the dust collector. If a machine is not being used, keep the blast gate closed to maintain higher levels of efficiency throughout the system.

Machine Storage

When the dust collector is not in use, unplug the power cord from the power source. Place the cord away from potential damage sources, such as high traffic areas, sharp objects, heat sources, harsh chemicals, water, damp areas, etc.



SECTION 6: ACCESSORIES

⚠️ WARNING

Some aftermarket accessories can be installed on this machine that could cause it to function improperly, increasing the risk of serious personal injury. To minimize this risk, only install accessories recommended for this machine by Grizzly.

NOTICE

Refer to the newest copy of the Grizzly Catalog for other accessories available for this machine.

Call 1-800-523-4777 To Order

T20543— 41" x 31" Flat 19.75" Dia. Plastic Bottom Bag

Replacement plastic lower bag for G0548Z/ G0548ZP, G1029Z2/G1029Z2P, and G1028Z2.

H5783—Extra 1 Micron Canister

Replacement canister for Grizzly G0548Z/ G0548ZP, G0562Z/G0562ZP, G1028Z/Z2, G1029Z/Z2/Z2P, and G1030Z/Z2/Z2P Dust Collectors.



Figure 59. Replacement canister.

G5556—2.5 Micron Dust Bag

Replacement top bag for Grizzly G1028Z2 and G1029Z2/G1029Z2P dust collectors. These offer the largest airflow, least differential pressure and best overall efficiency available. Micro-porous to shed dust and dirt, so bags empty quickly and completely. 2.5 Microns! Captures the finest, most hazardous dust.



Figure 60. G5556 2.5 Micron Dust Bag.

G1536—Black Flexible Hose 4" x 10'

G2974—Wire Hose Clamp 4"

G1843—Plastic Blast Gate 4"

G4679—Anti-Static Grounding Kit

We've hand picked a selection of commonly used dust collection components for machines with 4" dust ports.

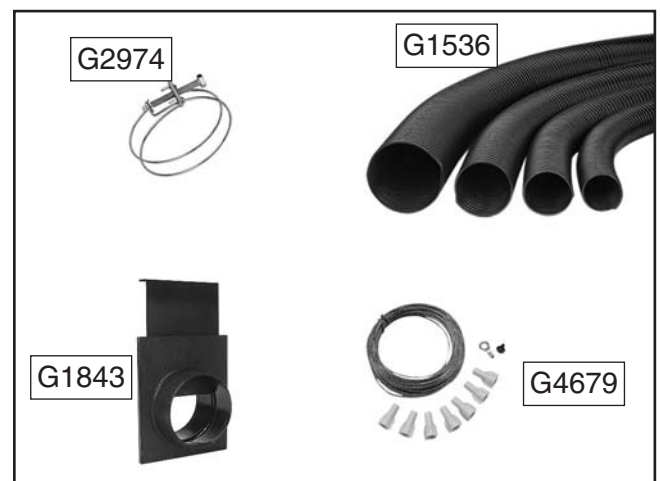

Figure 61. Dust collection accessories.

H5293—4" Metal Duct Starter Kit

H5295—5" Metal Duct Starter Kit

H5297—6" Metal Duct Starter Kit

Save over 20% with this great starter kit. Includes: (2) machine adapters, (10) pipe clamps, (3) 5' straight pipes, (1) branch, (3) pipe hangers, (1) end cap, (3) adjustable nipples, (1) 90° elbow, and (1) 60° elbow.

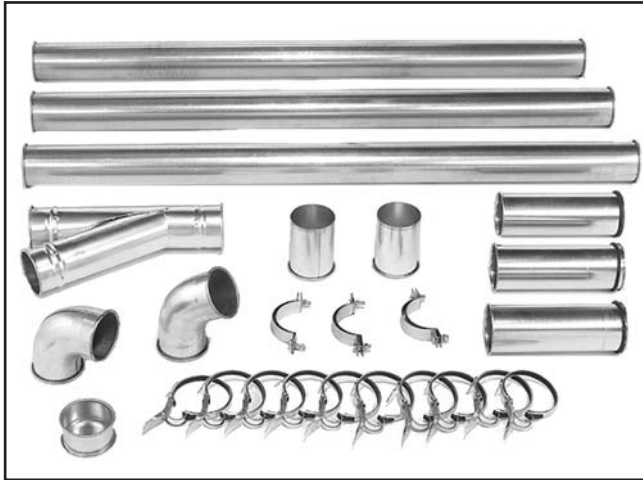

Figure 62. Metal Duct Starter Kit.

G6163—4" Clamp

G7343—5" Clamp

G7361—6" Clamp

These clamps feature lever latches and foam seals, and secure around the rolled ends of fittings and pipe.



Figure 63. Dust collection pipe clamps.

G6162—4" x 5' Straight Metal Pipe

G7346—5" x 5' Straight Metal Pipe

G7364—6" x 5' Straight Metal Pipe

These laser welded straight pipes ensure a super smooth internal seam. Ends easily clamp together for a sealed fit without screws or silicone.



Figure 64. Straight Metal Pipe.

H7215—4" x 5' Rigid Metal Flex Hose

H7216—5" x 5' Rigid Metal Flex Hose

H7217—6" x 5' Rigid Metal Flex Hose

This flex hose provides just enough flexibility to make difficult connections while still keeping the inside wall as smooth as possible to minimize static pressure loss.

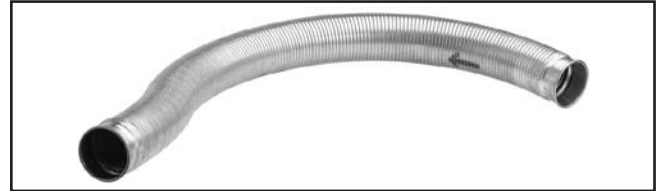

Figure 65. Rigid Metal Flex Hose.

Metal Elbows

These industrial metal elbows are available from 4"—8" with 90°, 60°, 45°, or 30° curves.

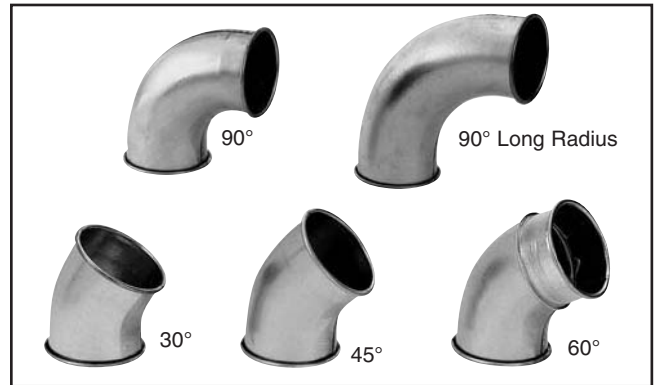

Figure 66. Metal elbow examples.

Reducers & Adapters

We carry a multitude of reducers and elbows to cover most applications from 4" through 9".



Figure 67. Metal Reducers & Adapters.

Metal Branches

We carry a selection of different branches.



Figure 68. Metal Branches.



SECTION 7: MAINTENANCE



Schedule

For optimum performance from your machine, follow this maintenance schedule and refer to any specific instructions given in this section.

Daily Check:

- Loose mounting bolts.
- Worn switch.
- Worn or damaged wires.
- Clean canister filter (G0548Z/ZP only).
- Check collection bag.
- Any other unsafe condition.

Lubrication

Since all bearings are shielded and permanently lubricated, simply leave them alone until they need to be replaced. Do not lubricate them.

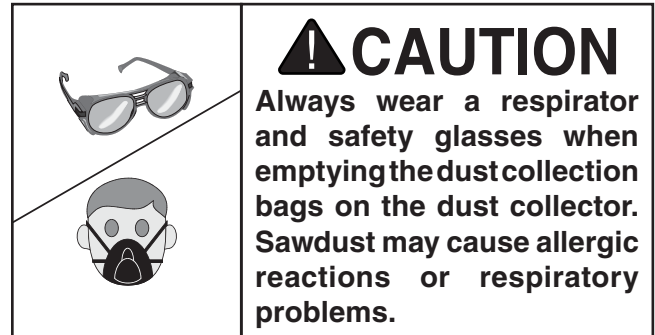

Cleaning Bags

Always empty the collection bags on a regular basis. Emptying the collection bags allows the machine to operate at a much higher level of efficiency.

Always wear the appropriate respirator or dust mask and safety glasses when emptying the collection bags. Small dust particles can escape the bags during emptying, causing them to become airborne and easily inhaled. This microscopic airborne dust is extremely unhealthy to breathe and can cause serious health problems.

While this dust collector excels at collecting the majority of wood dust produced by your machines, it is not an air filter; therefore, **we strongly recommend** the supplemental aid of a shop air filter such as the Grizzly G0572 or G9956. Air filters are designed to collect the smaller dust particles that dust collector bags cannot trap.



Replacing Bags

Replacement plastic lower collection bags are available through Grizzly as Model T20543. Replacement top dust bags are available for the Model G1028Z2/G1029Z2/Z2P as Model G5556.

To replace the collection bag:

1. DISCONNECT MACHINE FROM POWER!
2. Make sure you are wearing safety glasses and a respirator.
3. Release the belt clamp securing the collection bag, then unhook the bag from the collector.
4. Securely close the top of the bag and safely dispose of it according to local and federal standards.
5. Install a new collection bag.

Cleaning Canister Filter

To clean the canister filter on the Model G0548Z/ZP, move the canister cleaning handle back-and-forth to free the trapped dust particles from the filter pleats (see **Figure 69**). The particles will fall into the collection bag.

The replacement canister for the G0548Z/ZP is the Model H5783, which can also be installed on the G1028Z2/G1029Z2/Z2P, if you would ever like to upgrade.



Figure 69. Canister cleaning handle directions.

NOTICE

The use of compressed air or liquids to clean the canister filter will damage the filtration pleats of the filter. Use **ONLY** the cleaning handle or, if necessary, a soft brush to clean the inside of the canister filter.



SECTION 8: SERVICE

Review the troubleshooting and procedures in this section if a problem develops with your machine. If you need replacement parts or additional help with a procedure, call our Technical Support at (570) 546-9663.

Note: Please gather the serial number and manufacture date of your machine before calling.

To reduce the risk of serious personal injury or damage to the machine, any repairs not covered in this manual should only be performed by or with the assistance of qualified service personnel.

Troubleshooting

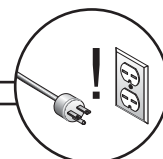

Motor & Electrical

Symptom	Possible Cause	Possible Solution
Machine does not start or a breaker trips.	<ol style="list-style-type: none">1. Switch disabling key removed.2. Power supply switched OFF or is at fault.3. Wall fuse/circuit breaker is blown/tripped.4. Wiring is open/has high resistance.5. Motor ON/OFF switch is at fault.6. Motor is at fault.	<ol style="list-style-type: none">1. Install switch disabling key.2. Ensure power supply is switched ON; ensure power supply has the correct voltage.3. Ensure circuit size is suitable for this machine; replace weak breaker.4. Check for broken wires or disconnected/corroded connections, and repair/replace as necessary.5. Replace faulty ON/OFF switch.6. Test/repair/replace.
Machine has vibration or noisy operation.	<ol style="list-style-type: none">1. Motor, motor mount, or other mounting component is loose or broken.2. Machine is incorrectly "mounted" or sits unevenly on its casters.3. Motor fan is rubbing on fan cover.4. Impeller is loose or damaged and unbalanced.5. Motor bearings are at fault.	<ol style="list-style-type: none">1. Retighten. Use thread locking fluid if necessary. Replace stripped fasteners or damaged components if necessary.2. Tighten/replace anchor studs in floor if mounted; chock machine casters if mobile.3. Replace dented fan cover; replace loose/damaged fan.4. Disconnect dust collector from power, and inspect the impeller for dents, bends, loose fins. Replace the motor and impeller as a set if the motor shaft and the impeller hub are damaged.5. Test by rotating shaft; rotational grinding/loose shaft requires bearing replacement.



Dust Collector Operation

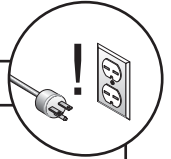

Symptom	Possible Cause	Possible Solution
Dust collector does not adequately collect dust or chips; poor performance.	<ol style="list-style-type: none"> 1. Dust collection bags are full. 2. Canister is dirty. 3. Restriction in duct line. 4. Dust collector is too far away, or there are too many sharp bends in the ducting. 5. Lumber is wet and dust not flowing through ducting smoothly. 6. Leaks in ducting or too many open ports. 7. Not enough open branch lines, causing a velocity drop in the main line. 8. Ducting or machine dust ports are incorrectly sized. 9. The machine dust collection design is inadequate. 10. The dust collector is too small for the dust collection system, or ducting layout design inadequate. 	<ol style="list-style-type: none"> 1. Empty collection bags. 2. Clean canister. 3. Remove restriction in the duct line. A plumbing snake may be necessary. 4. Relocate the dust collector closer to the point of suction, and rework ducting without sharp bends. Refer to System Design, beginning on Page 27. 5. Process lumber with less than 20% moisture content. 6. Rework the ducting to eliminate all leaks. Close dust ports for lines not being used. 7. Open 1 or 2 more blast gates to different branch lines to allow the velocity in the main line to increase. 8. Re-install correctly sized ducts and fittings. Refer to System Design beginning on Page 27 for more solutions. 9. Use a dust collection nozzle on a stand. 10. Install a larger dust collector to power your dust collection system.
Sawdust being blown into the air from the dust collector.	<ol style="list-style-type: none"> 1. Duct clamps or dust collection bags are not properly clamped and secured. 	<ol style="list-style-type: none"> 1. Re-secure ducts and dust collection bag, making sure duct and bag clamps are tight and completely over the ducts and bags.



SECTION 9: WIRING

These pages are current at the time of printing. However, in the spirit of improvement, we may make changes to the electrical systems of future machines. Compare the manufacture date of your machine to the one stated in this manual, and study this section carefully.

If there are differences between your machine and what is shown in this section, call Technical Support at (570) 546-9663 for assistance BEFORE making any changes to the wiring on your machine. An updated wiring diagram may be available. **Note:** Please gather the serial number and manufacture date of your machine before calling. This information can be found on the main machine label.

WARNING

Wiring Safety Instructions

SHOCK HAZARD. Working on wiring that is connected to a power source is extremely dangerous. Touching electrified parts will result in personal injury including but not limited to severe burns, electrocution, or death. Disconnect the power from the machine before servicing electrical components!

MODIFICATIONS. Modifying the wiring beyond what is shown in the diagram may lead to unpredictable results, including serious injury or fire. This includes the installation of unapproved after-market parts.

WIRE CONNECTIONS. All connections must be tight to prevent wires from loosening during machine operation. Double-check all wires disconnected or connected during any wiring task to ensure tight connections.

CIRCUIT REQUIREMENTS. You MUST follow the requirements at the beginning of this manual when connecting your machine to a power source.

WIRE/COMPONENT DAMAGE. Damaged wires or components increase the risk of serious personal injury, fire, or machine damage. If you notice that any wires or components are damaged while performing a wiring task, replace those wires or components.

MOTOR WIRING. The motor wiring shown in these diagrams is current at the time of printing but may not match your machine. If you find this to be the case, use the wiring diagram inside the motor junction box.





CAPACITORS/INVERTERS. Some capacitors and power inverters store an electrical charge for up to 10 minutes after being disconnected from the power source. To reduce the risk of being shocked, wait at least this long before working on capacitors.

EXPERIENCING DIFFICULTIES. If you are experiencing difficulties understanding the information included in this section, contact our Technical Support at (570) 546-9663.

NOTICE

The photos and diagrams included in this section are best viewed in color. You can view these pages in color at www.grizzly.com.

COLOR KEY

BLACK		BLUE		YELLOW		LIGHT BLUE	
WHITE		BROWN		YELLOW GREEN		BLUE WHITE	
GREEN		GRAY		PURPLE		TURQUOISE	
RED		ORANGE		PINK			



G0548Z/G0548ZP Wiring Diagram

240 VOLT

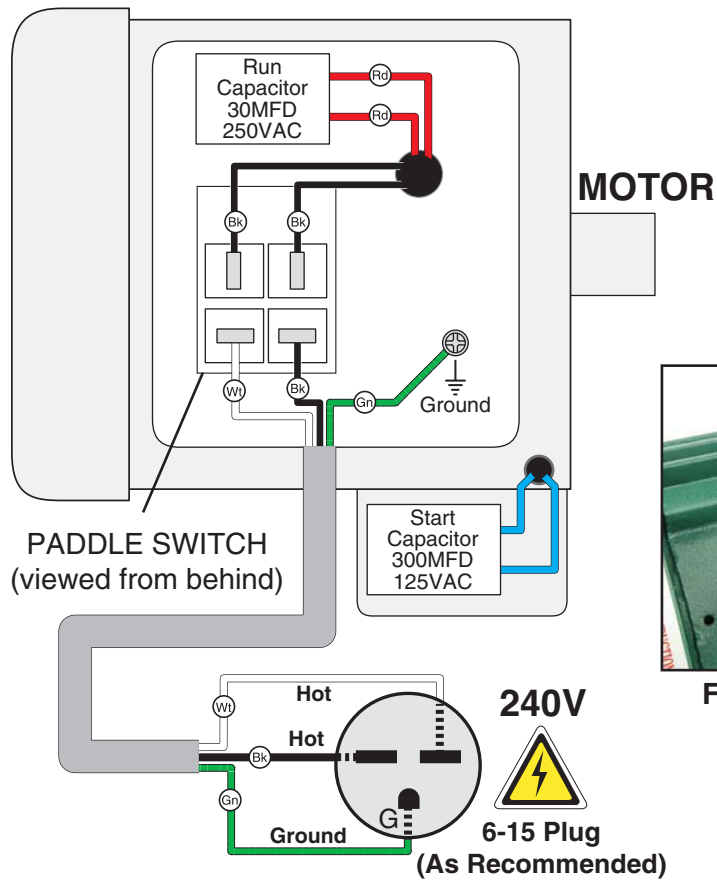

Figure 70. G0548Z start capacitor.

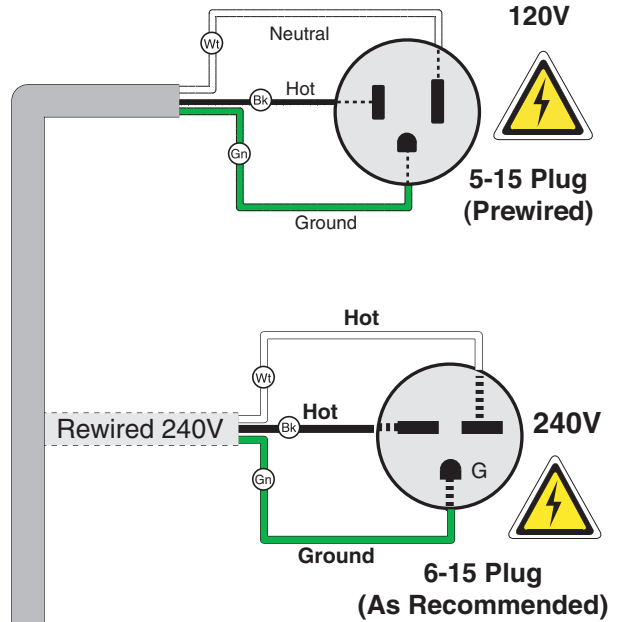
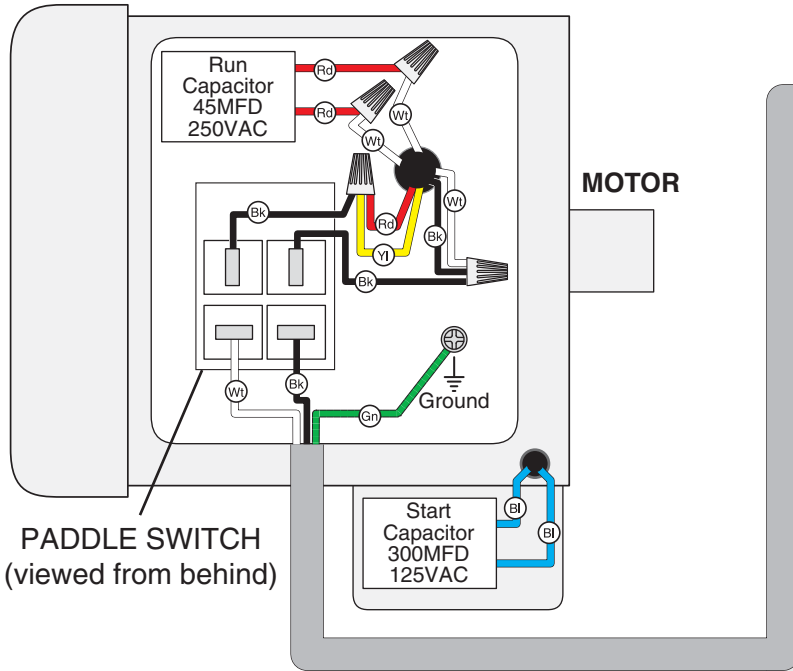

Figure 71. G0548Z junction box, switch and run capacitor.



G1028Z2 Wiring Diagram

120 VOLT (PREWIRED)



240 VOLT (REWIRED)

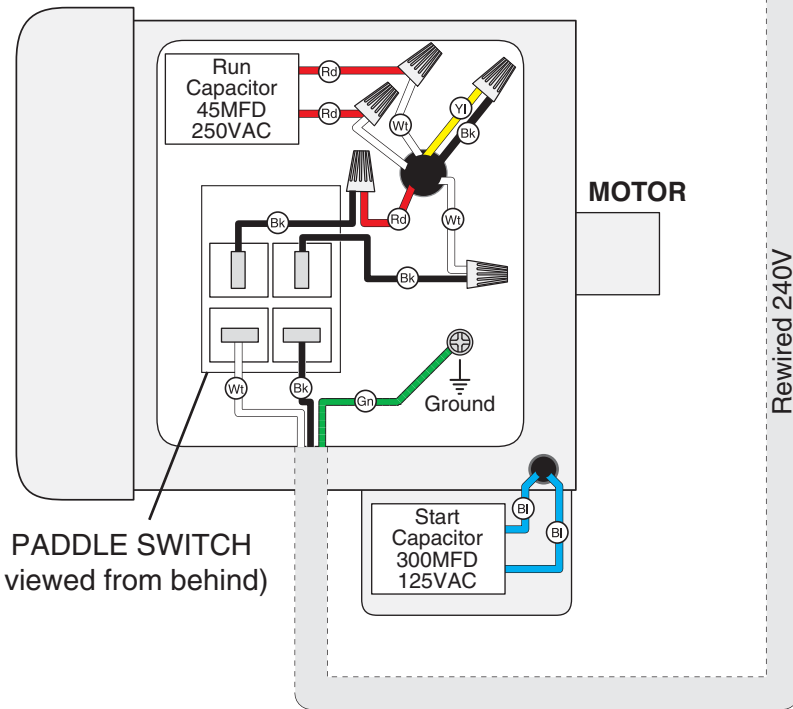

Figure 72. G1028Z2 start capacitor.



Figure 73. G1028Z2 junction box, switch and run capacitor at 120V.



G1029Z2/G1029Z2P Wiring Diagram

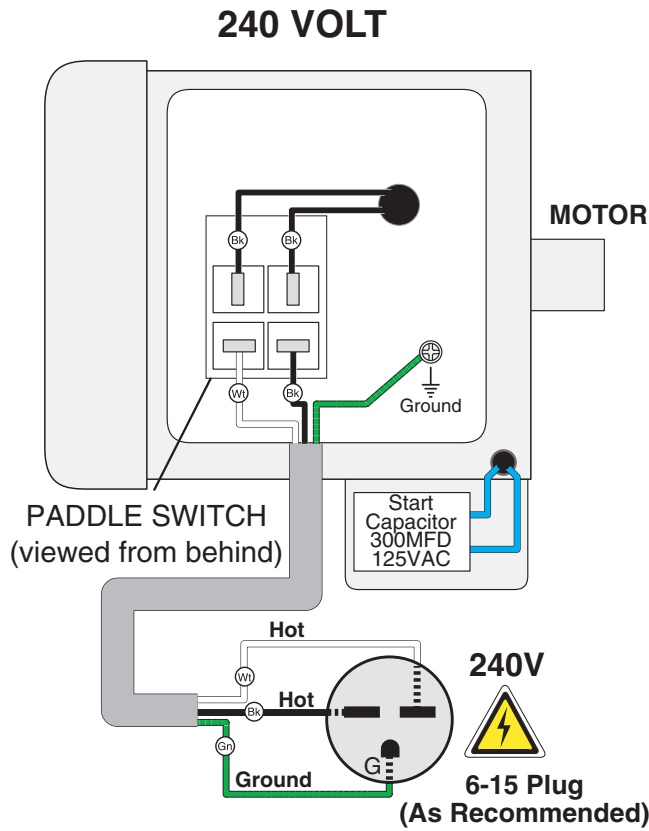

Figure 74. G1029Z2 start capacitor.

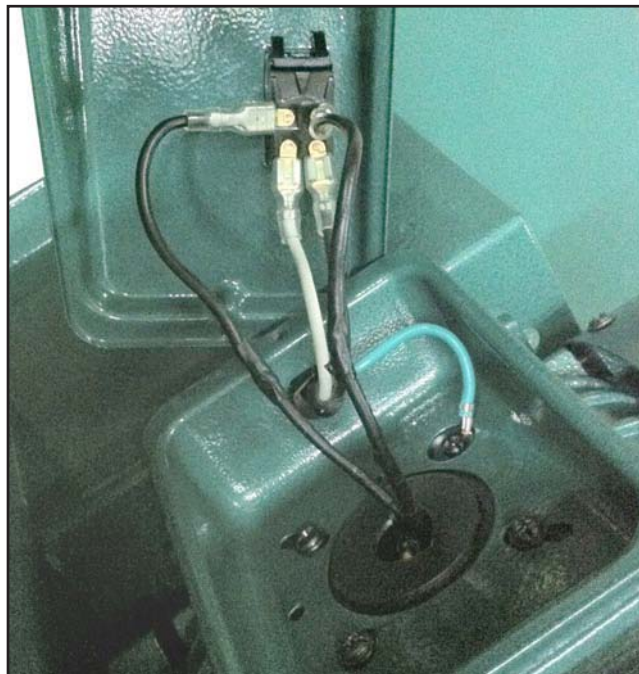
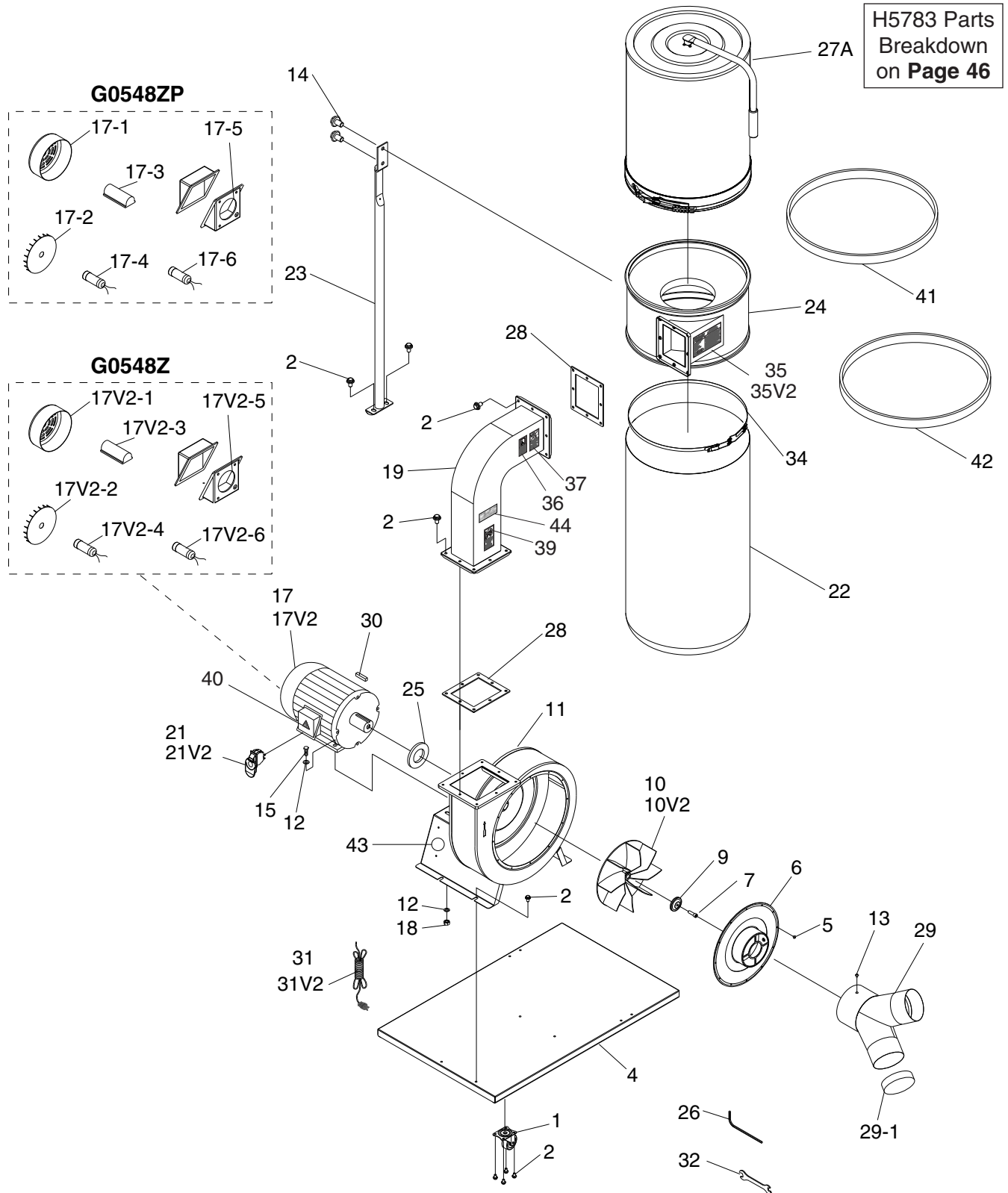

Figure 75. G1029Z2 junction box and switch.

SECTION 10: PARTS

G0548Z/G0548ZP Main Breakdown



G0548Z Main Parts List

REF	PART #	DESCRIPTION
1	P1028Z2001	CASTERS
2	PFB01	FLANGE BOLT 5/16-18 X 1/2
4	P1028Z2004	BASE PLATE
5	PS06	PHLP HD SCR 10-24 X 3/8
6	P1028Z2006	6" INLET COVER V2.10.01
7	PCAP121M	CAP SCREW M6-1 X 20 (LH)
9	P0548009	IMPELLER WASHER 7 X 40 X 4
10V2	P1029Z2010V2	IMPELLER 12-3/4" ALUMINUM V2.09.11
11	P1028Z2011	COLLECTOR BODY
12	PW07	FLAT WASHER 5/16
13	PS06	PHLP HD SCR 10-24 X 3/8
14	PFB01	FLANGE BOLT 5/16-18 X 1/2
15	PB03	HEX BOLT 5/16-18 X 1
17V2	P0548Z017V2	MOTOR 2HP 220V 1PH V2.09.11
17V2-1	P0548Z017V2-1	MOTOR FAN COVER
17V2-2	P0548Z017V2-2	MOTOR FAN
17V2-3	P0548Z017V2-3	CAPACITOR COVER
17V2-4	PC300B	S CAPACITOR 300M 125V 1-3/4 X 3-3/8
17V2-5	P0548Z017V2-5	MOTOR WIRING JUNCTION BOX
17V2-6	P0548Z017V2-6	R CAPACITOR 30M 250V 1-3/8 X 2-3/8
18	PN02	HEX NUT 5/16"-18
19	P0548Z019	OUTLET CONNECTOR

REF	PART #	DESCRIPTION
21V2	P1030Z2015V2	PADDLE SWITCH V2.09.11
22	T20543	COLLECTION BAG
23	P0548Z023	COLLECTOR SUPPORT
24	P0548Z024	COLLECTOR
25	P0548Z025	SPACER
26	PAW05M	WRENCH HEX 5MM
27A	H5783	COMPLETE CANISTER ASSY
28	P1028Z2028	RUBBER GASKET
29	P1030Z2027	INLET
29-1	P0548Z029-1	INLET CAP
30	PK28M	KEY 7 X 7 X 29
31V2	P1029Z2013V2	POWER CORD 14G 3W 6' 6-15 V2.09.11
32	PWR1012	WRENCH 10 X 12MM OPEN-END
34	P1028Z2031	BELT CLAMP
35V2	P0548Z035V2	MACHINE ID LABEL CSA V2.09.11
36	PLABEL-12	READ MANUAL 2W X 3.3H
37	PLABEL-57	EYE/LUNG LABEL
39	PLABEL-59	NO HAND IN INLET LABEL
40	PLABEL-14	ELECTRICITY LABEL 1.4W X 1.2H
41	P0548Z041	FOAM STRIP 5 X 42MM
42	P0548Z042	FOAM STRIP 4 X 20MM
43	PPAINT-1	GRIZZLY GREEN PAINT

G0548ZP Main Parts List

REF	PART #	DESCRIPTION
1	P1028Z2001	CASTERS
2	PFB01	FLANGE BOLT 5/16-18 X 1/2
4	P1028Z2004	BASE PLATE
5	PS06	PHLP HD SCR 10-24 X 3/8
6	P0548ZP006	6" INLET COVER
7	PCAP121M	CAP SCREW M6-1 X 20 (LH)
9	P0548009	IMPELLER WASHER 7 X 40 X 4
10	P1029Z2010V2	IMPELLER 12-3/4" ALUMINUM V2.09.11
11	P0548ZP011	COLLECTOR BODY
12	PW07	FLAT WASHER 5/16
13	PS06	PHLP HD SCR 10-24 X 3/8
14	PFB01	FLANGE BOLT 5/16-18 X 1/2
15	PB03	HEX BOLT 5/16-18 X 1
17	P0548ZP017	MOTOR 2HP 220V 1PH
17-1	P0548ZP017-1	MOTOR FAN COVER
17-2	P0548Z017V2-2	MOTOR FAN
17-3	P0548ZP017-3	CAPACITOR COVER
17-4	PC300B	S CAPACITOR 300M 125V 1-3/4 X 3-3/8
17-5	P0548ZP017-5	MOTOR WIRING JUNCTION BOX
17-6	P0548Z017V2-6	R CAPACITOR 30M 250V 1-3/8 X 2-3/8
18	PN02	HEX NUT 5/16"-18
19	P0548ZP019	OUTLET CONNECTOR
21	P1030Z2015V2	PADDLE SWITCH V2.09.11

REF	PART #	DESCRIPTION
22	T20543	COLLECTION BAG
23	P0548Z023	COLLECTOR SUPPORT
24	P0548ZP024	COLLECTOR
25	P0548Z025	SPACER
26	PAW05M	WRENCH HEX 5MM
27A	H5783	COMPLETE CANISTER ASSY
28	P1028Z2028	RUBBER GASKET
29	P1030Z2027	INLET
29-1	P0548Z029-1	INLET CAP
30	PK28M	KEY 7 X 7 X 29
31	P1029Z2013V2	PWR CORD 14G 3W 6' 6-15 V2.09.11
32	PWR1012	WRENCH 10 X 12MM OPEN-END
34	P1028Z2031	BELT CLAMP
35	P0548ZP035	MACHINE ID LABEL
36	PLABEL-12	READ MANUAL 2W X 3.3H
37	PLABEL-57	EYE/LUNG LABEL
39	PLABEL-59	NO HAND IN INLET LABEL
40	PLABEL-14	ELECTRICITY LABEL 1.4W X 1.2H
41	P0548Z041	FOAM STRIP 5 X 42MM
42	P0548Z042	FOAM STRIP 4 X 20MM
43	PPAINT-24	POLAR BEAR PAINT
44	PLABEL-81	POLAR BEAR LOGO 1 X 3-3/4



G1028Z2 Main Parts List

REF	PART #	DESCRIPTION
1	P1028Z2001	CASTER
2	PFB01	FLANGE BOLT 5/16-18 X 1/2
3	PK32M	KEY 6 X 6 X 28
4	P1028Z2004	BASE PLATE
5	PS06	PHLP HD SCR 10-24 X 3/8
6	P1028Z2006	INLET COVER 6"
7	PCAP121M	CAP SCREW M6-1 X 20 LH
9	P1028Z2009	IMPELLER WASHER
10V2	P1028Z2010V2	IMPELLER 12-3/4" ALUMINUM V2.09.11
11	P1028Z2011	COLLECTOR BODY
12	PW07	FLAT WASHER 5/16
13V2	P1028Z2013V2	POWER CORD 14G 3W 6' 5-15 V2.09.11
14	PN02	HEX NUT 5/16-18
15	PB03	HEX BOLT 5/16-18 X 1
16V2	P1030Z2016V2	PADDLE SWITCH V2.09.11
17V2	P1028Z2017V2	MOTOR 1-1/2HP 120V/240V 1PH V2.09.11
17V2-1	P1028Z2017V2-1	MOTOR FAN COVER
17V2-2	P1028Z2017V2-2	MOTOR FAN
17V2-3	P1028Z2017V2-3	CAPACITOR COVER
17V2-4	PC300G	S CAPACITOR 300M 125V 1-3/4 X 3-3/8
17V2-5	P1028Z2017V2-5	JUNCTION BOX
17V2-6	P1028Z2017V2-6	R CAPACITOR 45M 250V 1-3/4 x 2-3/8
18	PS06	PHLP HD SCR 10-24 X 3/8

REF	PART #	DESCRIPTION
19	P1028Z2019	OUTLET
20	P1028Z2020	HOSE CLAMP 5"
21	P1028Z2021	HOSE 5"
22	T20543	LOWER PLASTIC BAG
23	P1028Z2023	COLLECTOR SUPPORT
24	P1028Z2024	COLLECTOR
25	P1028Z2025	SPACER
26	P1028Z2026	UPPER BAG SUPPORT
27	G5556	2.5 MICRON FILTER BAG
28	P1028Z2028	GASKET
29	P1028Z2029	Y-INLET 6 X 4 X 4"
29-1	P1028Z2029-1	INLET CAP 4"
30	P1028Z2030	FOAM STRIP 5 X 20MM
31	P1028Z2031	BELT CLAMP
32	PWR1012	WRENCH 10 X 12MM OPEN-END
33	PAW05M	WRENCH HEX 5MM
101	PLABEL-14	ELECTRICITY LABEL
102	PLABEL-59	HANDS/OUTLET LABEL
103	PLABEL-12A	READ MANUAL LABEL
104V2	P1028Z2104V2	MACHINE ID LABEL CSA V2.09.11
105	PLABEL-57	EYE/LUNG LABEL
106	PPAINT-1	GRIZZLY GREEN PAINT

G1029Z2 Main Parts List

REF	PART #	DESCRIPTION
1	P1028Z2001	CASTER
2	PFB01	FLANGE BOLT 5/16-18 X 1/2
3	PK28M	KEY 7 X 7 X 29
4	P1028Z2004	BASE PLATE
5	PS06	PHLP HD SCR 10-24 X 3/8
6	P1028Z2006	INLET COVER 6"
7	PCAP121M	CAP SCREW M6-1 X 20 LH
9	P1028Z2009	IMPELLER WASHER
10V2	P1029Z2010V2	IMPELLER 12-3/4" ALUMINUM V2.09.11
11	P1028Z2011	COLLECTOR BODY
12	PW07	FLAT WASHER 5/16
13V2	P1029Z2013V2	POWER CORD 14G 3C 6' 6-15 V2.09.11
14	PN02	HEX NUT 5/16-18
15	PB03	HEX BOLT 5/16-18 X 1
16V2	P1030Z2015V2	PADDLE SWITCH V2.09.11
17V2	P1029Z2017V2	MOTOR 2HP 220V 1PH V2.09.11
17V2-1	P1028Z2017V2-1	MOTOR FAN COVER
17V2-2	P1028Z2017V2-2	MOTOR FAN
17V2-3	P1028Z2017V2-3	CAPACITOR COVER
17V2-4	PC300G	S CAPACITOR 300M 125V 1-3/4 X 3-3/8
17V2-5	P1029Z2017V2-5	JUNCTION BOX
18	PFS03	FLANGE SCREW 10-24 X 3/8

REF	PART #	DESCRIPTION
19	P1028Z2019	OUTLET
20	P1028Z2020	HOSE CLAMP 5"
21	P1028Z2021	HOSE 5"
22	T20543	LOWER PLASTIC BAG
23	P1028Z2023	COLLECTOR SUPPORT
24	P1028Z2024	COLLECTOR
25	P1028Z2025	SPACER
26	P1028Z2026	UPPER BAG SUPPORT
27	G5556	2.5 MICRON FILTER BAG
28	P1028Z2028	GASKET
29	P1028Z2029	6" X 4" X 4" Y-INLET
29-1	P1028Z2029-1	INLET CAP 4"
30	P1028Z2030	FOAM STRIP 5 X 20MM
31	P1028Z2031	BELT CLAMP
32	PWR1012	WRENCH 10 X 12MM OPEN-END
33	PAW05M	WRENCH HEX 5MM
101	PLABEL-14	ELECTRICITY LABEL
102	PLABEL-59	HANDS/OUTLET LABEL
103	PLABEL-12A	READ MANUAL LABEL
104V2	P1029Z2104V2	MACHINE ID LABEL CSA V2.09.11
105	PLABEL-57	EYE/LUNG LABEL
106	PPAINT-1	GRIZZLY GREEN PAINT



G1029Z2P Main Breakdown

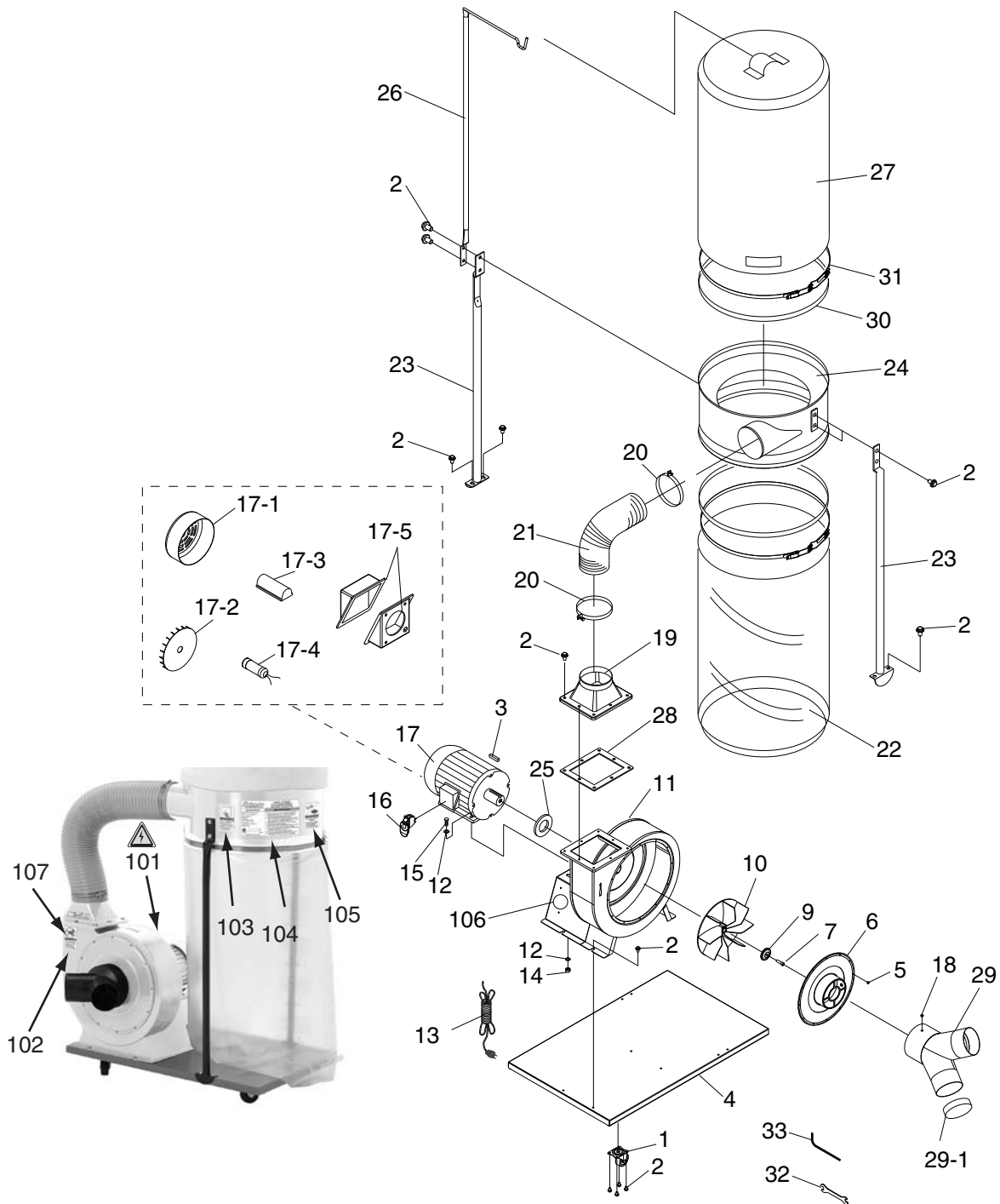

G1029Z2P Main Parts List

REF	PART #	DESCRIPTION
1	P1028Z2001	CASTER
2	PFB01	FLANGE BOLT 5/16-18 X 1/2
3	PK28M	KEY 7 X 7 X 29
4	P1028Z2004	BASE PLATE
5	PS06	PHLP HD SCR 10-24 X 3/8
6	P1029Z2P006	INLET COVER 6"
7	PCAP121M	CAP SCREW M6-1 X 20 LH
9	P1028Z2009	IMPELLER WASHER
10	P1029Z2010V2	IMPELLER 12-3/4" ALUMINUM V2.09.11
11	P1029Z2P011	COLLECTOR BODY
12	PW07	FLAT WASHER 5/16
13	P1029Z2013V2	POWER CORD 14G 3C 6' 6-15 V2.09.11
14	PN02	HEX NUT 5/16-18
15	PB03	HEX BOLT 5/16-18 X 1
16	P1030Z2015V2	PADDLE SWITCH V2.09.11
17	P1029Z2P017	MOTOR 2HP 220V 1PH
17-1	P1029Z2P017-1	MOTOR FAN COVER
17-2	P1028Z2017V2-2	MOTOR FAN
17-3	P1029Z2P017-3	CAPACITOR COVER
17-4	PC300G	S CAPACITOR 300M 125V 1-3/4 X 3-3/8
17-5	P1029Z2P017-5	JUNCTION BOX
18	PFS03	FLANGE SCREW 10-24 X 3/8
19	P1029Z2P019	OUTLET

REF	PART #	DESCRIPTION
20	P1028Z2020	HOSE CLAMP 5"
21	P1028Z2021	HOSE 5"
22	T20543	LOWER PLASTIC BAG
23	P1028Z2023	COLLECTOR SUPPORT
24	P1029Z2P024	COLLECTOR
25	P1028Z2025	SPACER
26	P1028Z2026	UPPER BAG SUPPORT
27	G5556	2.5 MICRON FILTER BAG
28	P1028Z2028	GASKET
29	P1028Z2029	6" X 4" X 4" Y-INLET
29-1	P1028Z2029-1	INLET CAP 4"
30	P1028Z2030	FOAM STRIP 5 X 20MM
31	P1028Z2031	BELT CLAMP
32	PWR1012	WRENCH 10 X 12MM OPEN-END
33	PAW05M	WRENCH HEX 5MM
101	PLABEL-14	ELECTRICITY LABEL
102	PLABEL-59	HANDS/OUTLET LABEL
103	PLABEL-12A	READ MANUAL LABEL
104	P1029Z2P104	MACHINE ID LABEL
105	PLABEL-57	EYE/LUNG LABEL
106	PPAINT-24	POLAR BEAR PAINT
107	PLABEL-81	POLAR BEAR LOGO 1 X 3-3/4

WARNING

Safety labels warn about machine hazards and ways to prevent injury. The owner of this machine **MUST** maintain the original location and readability of the labels on the machine. If any label is removed or becomes unreadable, **REPLACE** that label before using the machine again. Contact Grizzly at (800) 523-4777 or www.grizzly.com to order new labels.





WARRANTY CARD

Name _____
 Street _____
 City _____ State _____ Zip _____
 Phone # _____ Email _____ Invoice # _____
 Model # _____ Order # _____ Serial # _____

The following information is given on a voluntary basis. It will be used for marketing purposes to help us develop better products and services. **Of course, all information is strictly confidential.**

1. How did you learn about us?

<input type="checkbox"/> Advertisement	<input type="checkbox"/> Friend	<input type="checkbox"/> Catalog
<input type="checkbox"/> Card Deck	<input type="checkbox"/> Website	<input type="checkbox"/> Other: _____

2. Which of the following magazines do you subscribe to?

<input type="checkbox"/> Cabinetmaker & FDM	<input type="checkbox"/> Popular Science	<input type="checkbox"/> Wooden Boat
<input type="checkbox"/> Family Handyman	<input type="checkbox"/> Popular Woodworking	<input type="checkbox"/> Woodshop News
<input type="checkbox"/> Hand Loader	<input type="checkbox"/> Precision Shooter	<input type="checkbox"/> Woodsmith
<input type="checkbox"/> Handy	<input type="checkbox"/> Projects in Metal	<input type="checkbox"/> Woodwork
<input type="checkbox"/> Home Shop Machinist	<input type="checkbox"/> RC Modeler	<input type="checkbox"/> Woodworker West
<input type="checkbox"/> Journal of Light Cont.	<input type="checkbox"/> Rifle	<input type="checkbox"/> Woodworker's Journal
<input type="checkbox"/> Live Steam	<input type="checkbox"/> Shop Notes	<input type="checkbox"/> Other: _____
<input type="checkbox"/> Model Airplane News	<input type="checkbox"/> Shotgun News	
<input type="checkbox"/> Old House Journal	<input type="checkbox"/> Today's Homeowner	
<input type="checkbox"/> Popular Mechanics	<input type="checkbox"/> Wood	

3. What is your annual household income?

<input type="checkbox"/> \$20,000-\$29,000	<input type="checkbox"/> \$30,000-\$39,000	<input type="checkbox"/> \$40,000-\$49,000
<input type="checkbox"/> \$50,000-\$59,000	<input type="checkbox"/> \$60,000-\$69,000	<input type="checkbox"/> \$70,000+

4. What is your age group?

<input type="checkbox"/> 20-29	<input type="checkbox"/> 30-39	<input type="checkbox"/> 40-49
<input type="checkbox"/> 50-59	<input type="checkbox"/> 60-69	<input type="checkbox"/> 70+

5. How long have you been a woodworker/metalworker?

<input type="checkbox"/> 0-2 Years	<input type="checkbox"/> 2-8 Years	<input type="checkbox"/> 8-20 Years	<input type="checkbox"/> 20+ Years
------------------------------------	------------------------------------	-------------------------------------	------------------------------------

6. How many of your machines or tools are Grizzly?

<input type="checkbox"/> 0-2	<input type="checkbox"/> 3-5	<input type="checkbox"/> 6-9	<input type="checkbox"/> 10+
------------------------------	------------------------------	------------------------------	------------------------------

7. Do you think your machine represents a good value? Yes No
8. Would you recommend Grizzly Industrial to a friend? Yes No
9. Would you allow us to use your name as a reference for Grizzly customers in your area?
Note: We never use names more than 3 times. Yes No

10. Comments: _____

CUT ALONG DOTTED LINE

FOLD ALONG DOTTED LINE



Place
Stamp
Here



GRIZZLY INDUSTRIAL, INC.
P.O. BOX 2069
BELLINGHAM, WA 98227-2069



FOLD ALONG DOTTED LINE

Send a Grizzly Catalog to a friend:

Name _____
Street _____
City _____ State _____ Zip _____

TAPE ALONG EDGES--PLEASE DO NOT STAPLE

WARRANTY AND RETURNS

Grizzly Industrial, Inc. warrants every product it sells for a period of **1 year** to the original purchaser from the date of purchase. This warranty does not apply to defects due directly or indirectly to misuse, abuse, negligence, accidents, repairs or alterations or lack of maintenance. This is Grizzly's sole written warranty and any and all warranties that may be implied by law, including any merchantability or fitness, for any particular purpose, are hereby limited to the duration of this written warranty. We do not warrant or represent that the merchandise complies with the provisions of any law or acts unless the manufacturer so warrants. In no event shall Grizzly's liability under this warranty exceed the purchase price paid for the product and any legal actions brought against Grizzly shall be tried in the State of Washington, County of Whatcom.

We shall in no event be liable for death, injuries to persons or property or for incidental, contingent, special, or consequential damages arising from the use of our products.

To take advantage of this warranty, contact us by mail or phone and give us all the details. We will then issue you a "Return Number," which must be clearly posted on the outside as well as the inside of the carton. We will not accept any item back without this number. Proof of purchase must accompany the merchandise.

The manufacturers reserve the right to change specifications at any time because they constantly strive to achieve better quality equipment. We make every effort to ensure that our products meet high quality and durability standards and we hope you never need to use this warranty.

Please feel free to write or call us if you have any questions about the machine or the manual.

Thank you again for your business and continued support. We hope to serve you again soon.

grizzly.com[®]

TOOL WEBSITE

Buy Direct and Save with Grizzly[®] – Trusted, Proven and a Great Value!
~Since 1983~

*Visit Our Website Today For
Current Specials!*

**ORDER
24 HOURS A DAY!
1-800-523-4777**



Free Manuals Download Website

<http://myh66.com>

<http://usermanuals.us>

<http://www.somanuals.com>

<http://www.4manuals.cc>

<http://www.manual-lib.com>

<http://www.404manual.com>

<http://www.luxmanual.com>

<http://aubethermostatmanual.com>

Golf course search by state

<http://golfingnear.com>

Email search by domain

<http://emailbydomain.com>

Auto manuals search

<http://auto.somanuals.com>

TV manuals search

<http://tv.somanuals.com>