

Grizzly **Industrial, Inc.**®

MODEL H7762 HEAVY DUTY TOOL GRINDER OWNER'S MANUAL



COPYRIGHT © NOVEMBER, 2005 BY GRIZZLY INDUSTRIAL, INC.
**WARNING: NO PORTION OF THIS MANUAL MAY BE REPRODUCED IN ANY SHAPE
OR FORM WITHOUT THE WRITTEN APPROVAL OF GRIZZLY INDUSTRIAL, INC.**
#JK7709 PRINTED IN CHINA



WARNING!

Some dust created by power sanding, sawing, grinding, drilling, and other construction activities contains chemicals known to the State of California to cause cancer, birth defects or other reproductive harm. Some examples of these chemical are:

- **Lead from lead-based paints.**
- **Crystalline silica from bricks, cement and other masonry products.**
- **Arsenic and chromium from chemically-treated lumber.**

Your risk from these exposures varies, depending on how often you do this type of work. To reduce your exposure to these chemicals: Work in a well ventilated area, and work with approved safety equipment, such as those dust masks that are specially designed to filter out microscopic particles.

WARNING

Safety labels warn about machine hazards and ways to prevent injury. The owner of this machine MUST maintain the original location and readability of the labels on the machine. If any label is removed or becomes unreadable, REPLACE that label before using the machine again. Contact Grizzly at (800) 523-4777 or www.grizzly.com to order new labels.

Table of Contents

INTRODUCTION	2
Foreword	2
Contact Info.....	2
Machine Data Sheet.....	3
Identification	4
SECTION 1: SAFETY	5
Safety Instructions for Machinery.....	5
SECTION 2: CIRCUIT REQUIREMENTS	8
110V Operation	8
SECTION 3: SET UP	9
Set Up Safety.....	9
Items Needed for Set Up	9
Unpacking	9
Inventory.....	10
Hardware Recognition Chart.....	11
Clean Up	12
Site Considerations	12
Mounting.....	13
Grinding Wheels.....	14
Work Tables	14
SECTION 4: OPERATION	16
Test Run.....	16
Grinding Tips.....	17
Operating Grinder	17
Wheel Care	18
Wheel Dressing.....	18
Wheel Selection	19
Wheel Inspection.....	19
Replacing Wheels	19
SECTION 5: ACCESSORIES	21
SECTION 6: MAINTENANCE	22
General.....	22
Lubrication.....	22
Grinding Wheels.....	22
SECTION 7: SERVICE	23
Troubleshooting.....	23
Parts Breakdown.....	24
Parts List	25
WARRANTY AND RETURNS	26

INTRODUCTION

Foreword

We are proud to offer the Model H7762 Heavy Duty Tool Grinder. This machine is part of a growing Grizzly family of fine woodworking machinery. When used according to the guidelines set forth in this manual, you can expect years of trouble-free, enjoyable operation and proof of Grizzly's commitment to customer satisfaction.

We are pleased to provide this manual with the Model H7762. It was written to guide you through assembly, review safety considerations, and cover general operating procedures. It represents our effort to produce the best documentation possible.

The specifications, drawings, and photographs illustrated in this manual represent the Model H7762 as supplied when the manual was prepared. However, owing to Grizzly's policy of continuous improvement, changes may be made at any time with no obligation on the part of Grizzly. For your convenience, we always keep current Grizzly manuals available on our website at **www.grizzly.com**. Any updates to your machine will be reflected in these manuals as soon as they are complete. Visit our site often to check for the latest updates to this manual!

Contact Info

If you have any comments regarding this manual, please write to us at the address below:

Grizzly Industrial, Inc.
c/o Technical Documentation Manager
P.O. Box 2069
Bellingham, WA 98227-2069

We stand behind our machines. If you have any service questions or parts requests, please call or write us at the location listed below.

Grizzly Industrial, Inc.
1203 Lycoming Mall Circle
Muncy, PA 17756
Phone: (570) 546-9663
Fax: (800) 438-5901
E-Mail: techsupport@grizzly.com
Web Site: <http://www.grizzly.com>





MACHINE DATA SHEET

Customer Service #: (570) 546-9663 • To Order Call: (800) 523-4777 • Fax #: (800) 438-5901

MODEL H7762 HEAVY DUTY TOOL GRINDER

Design Type Bench Model

Overall Dimensions:

Height (w/Work Light Extended)..... 23"
 Width 24³/₄"
 Depth 12³/₄"
 Shipping Weight 97.5 lbs.
 Net Weight..... 92.5 lbs.
 Footprint 8¹/₂" x 8"
 Arbor 1¹/₄"
 Wheel Size 6" x 1"
 Wheel Type Type 50
 Table Size..... 12" x 6³/₄"

Motor:

Type..... TEFC Capacitor-Start Induction
 Horsepower 1/2 HP
 Voltage/Phase 110V / Single-Phase
 Amps 6.3
 Cycle / RPM 60 Hertz / 3450 RPM
 Bearings Shielded & Permanently Lubricated

Features:

..... Work Support Tables
 Coolant Trays
 Two-Way Rocker-Type Switch
 Convenient Coolant Cup/Dispenser
 Includes Two Silicon Carbide 80 Grit Grinding Wheels

Specifications, while deemed accurate, are not guaranteed.



Identification

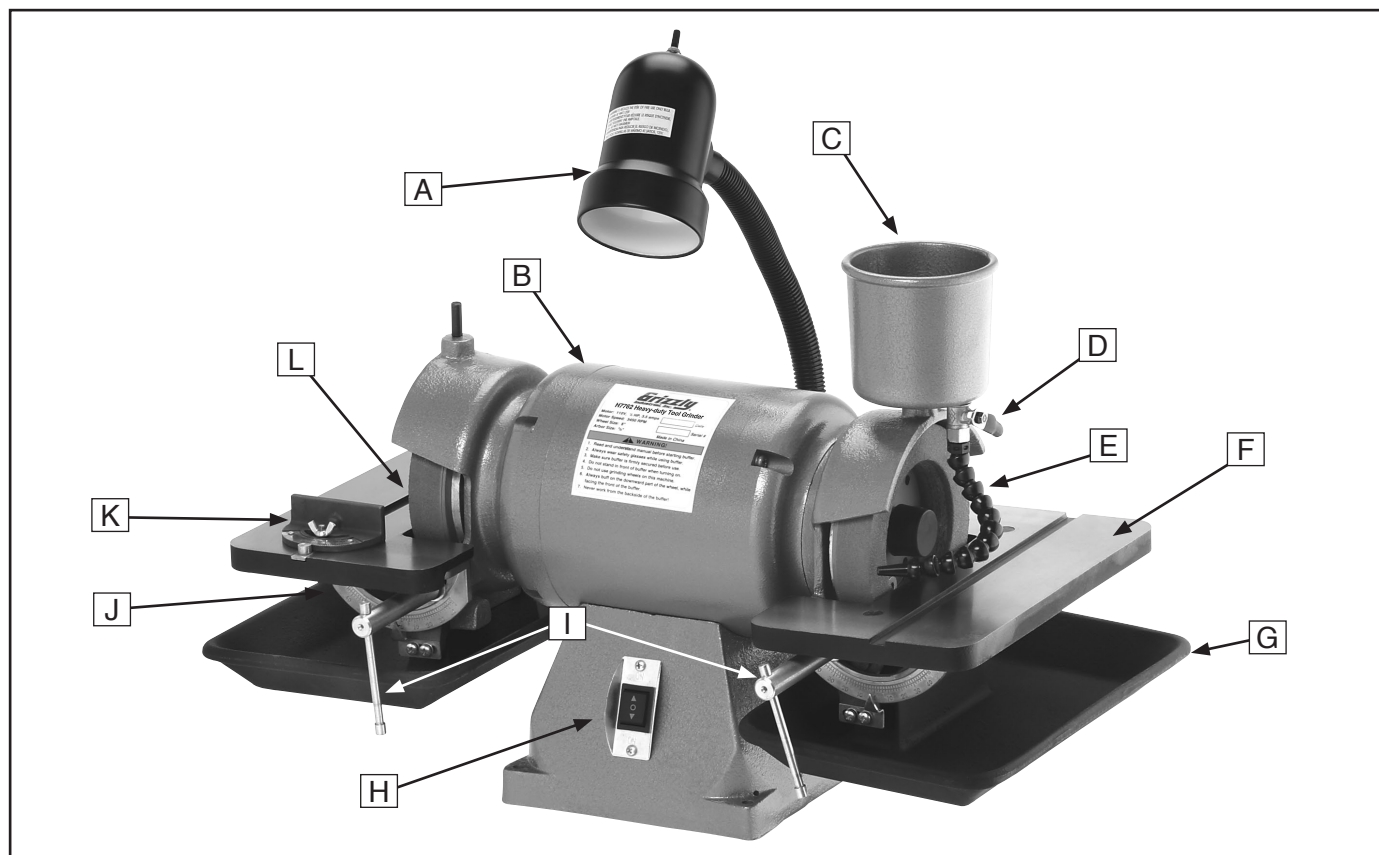

Figure 1. H7762 Identification.

- A. Flexible Work Light
- B. Grinder Body
- C. Water Cup
- D. Water Valve
- E. Water Pipe
- F. Work Table
- G. Water Tray
- H. Two-Way Power Switch
- I. Work Table Lock Handles (rear handles not shown)
- J. Work Table Angle Gauge
- K. Miter Gauge
- L. Grinding Wheel



SECTION 1: SAFETY

WARNING

For Your Own Safety, Read Instruction Manual Before Operating this Machine

The purpose of safety symbols is to attract your attention to possible hazardous conditions. This manual uses a series of symbols and signal words which are intended to convey the level of importance of the safety messages. The progression of symbols is described below. Remember that safety messages by themselves do not eliminate danger and are not a substitute for proper accident prevention measures.

 **DANGER** Indicates an imminently hazardous situation which, if not avoided, **WILL** result in death or serious injury.

 **WARNING** Indicates a potentially hazardous situation which, if not avoided, **COULD** result in death or serious injury.

 **CAUTION** Indicates a potentially hazardous situation which, if not avoided, **MAY** result in minor or moderate injury. It may also be used to alert against unsafe practices.

NOTICE This symbol is used to alert the user to useful information about proper operation of the machine.

WARNING

Safety Instructions for Machinery

- 1. READ THROUGH THE ENTIRE MANUAL BEFORE STARTING MACHINERY.** Machinery presents serious injury hazards to untrained users.
- 2. ALWAYS USE ANSI APPROVED SAFETY GLASSES WHEN OPERATING MACHINERY.** Everyday eyeglasses only have impact resistant lenses, they are **NOT** safety glasses.
- 3. ALWAYS WEAR AN ANSI APPROVED RESPIRATOR WHEN OPERATING MACHINERY THAT PRODUCES DUST.** Wood dust is a carcinogen and can cause cancer and severe respiratory illnesses.
- 4. ALWAYS USE HEARING PROTECTION WHEN OPERATING MACHINERY.** Machinery noise can cause permanent hearing damage.
- 5. WEAR PROPER APPAREL. DO NOT** wear loose clothing, gloves, neckties, rings, or jewelry which may get caught in moving parts. Wear protective hair covering to contain long hair and wear non-slip footwear.
- 6. NEVER OPERATE MACHINERY WHEN TIRED, OR UNDER THE INFLUENCE OF DRUGS OR ALCOHOL.** Be mentally alert at all times when running machinery.

WARNING

Safety Instructions for Machinery

7. **ONLY ALLOW TRAINED AND PROPERLY SUPERVISED PERSONNEL TO OPERATE MACHINERY.** Make sure operation instructions are safe and clearly understood.
8. **KEEP CHILDREN AND VISITORS AWAY.** Keep all children and visitors a safe distance from the work area.
9. **MAKE WORKSHOP CHILD PROOF.** Use padlocks, master switches, and remove start switch keys.
10. **NEVER LEAVE WHEN MACHINE IS RUNNING.** Turn power **OFF** and allow all moving parts to come to a complete stop before leaving machine unattended.
11. **DO NOT USE IN DANGEROUS ENVIRONMENTS. DO NOT** use machinery in damp, wet locations, or where any flammable or noxious fumes may exist.
12. **KEEP WORK AREA CLEAN AND WELL LIT.** Clutter and dark shadows may cause accidents.
13. **USE A GROUNDED EXTENSION CORD RATED FOR THE MACHINE AMPERAGE.** Undersized cords overheat and lose power. Replace extension cords if they become damaged. **DO NOT** use extension cords for 220V machinery.
14. **ALWAYS DISCONNECT FROM POWER SOURCE BEFORE SERVICING MACHINERY.** Make sure switch is in OFF position before reconnecting.
15. **MAINTAIN MACHINERY WITH CARE.** Keep blades sharp and clean for best and safest performance. Follow instructions for lubricating and changing accessories.
16. **MAKE SURE GUARDS ARE IN PLACE AND WORK CORRECTLY BEFORE USING MACHINERY.**
17. **REMOVE ADJUSTING KEYS AND WRENCHES.** Make a habit of checking for keys and adjusting wrenches before turning machinery **ON**.
18. **CHECK FOR DAMAGED PARTS BEFORE USING MACHINERY.** Check for binding and alignment of parts, broken parts, part mounting, loose bolts, and any other conditions that may affect machine operation. Repair or replace damaged parts.
19. **USE RECOMMENDED ACCESSORIES.** Refer to the instruction manual for recommended accessories. The use of improper accessories may cause risk of injury.
20. **DO NOT FORCE MACHINERY.** Work at the speed for which the machine or accessory was designed.
21. **SECURE WORKPIECE.** Use clamps or a vise to hold the workpiece when practical. A secured workpiece protects your hands and frees both hands to operate the machine.
22. **DO NOT OVERREACH.** Keep proper footing and balance at all times.
23. **MANY MACHINES WILL EJECT THE WORKPIECE TOWARD THE OPERATOR.** Know and avoid conditions that cause the workpiece to "kickback."
24. **ALWAYS LOCK MOBILE BASES (IF USED) BEFORE OPERATING MACHINERY.**
25. **BE AWARE THAT CERTAIN MATERIALS MAY CAUSE AN ALLERGIC REACTION** in people and animals, especially when exposed to fine dust. Make sure you know what type of dust you will be exposed to and always wear an approved respirator.



WARNING

Additional Safety Instructions For Grinders

- 1. EYE PROTECTION.** Grinding causes small particles to become airborne at a high rate of speed, which can cause serious eye damage. ALWAYS wear safety glasses when using this machine.
- 2. MOUNTING TO BENCH/STAND.** An unsecured grinder may become dangerously out of control during operation. Make sure grinder is FIRMLY secured to a bench/stand before use.
- 3. WHEEL SPEED RATING.** Wheels operated at a faster speed than rated for may break or fly apart. Before mounting a new wheel, be sure the wheel RPM rating is equal or higher than the speed of the grinder.
- 4. WHEEL INSPECTION.** Always visually inspect grinding wheels before use for cracks, chips, fractures or other damage. NEVER use a damaged wheel, and replace any potentially damaged wheels immediately.
- 5. STARTING GRINDER.** If a wheel IS damaged, it will usually fly apart shortly after start-up. To protect yourself, always stand to the side of the grinder when turning it **ON** and allow it to gain full speed before standing in front of it.
- 6. LUNG PROTECTION.** Grinding produces hazardous dust, which may cause long-term respiratory problems if breathed. Always wear a NIOSH approved dust mask or respirator when grinding.
- 7. WHEEL DIRECTION.** Only grind on the downward side of the wheel. DO NOT grind on the part of the wheel moving away from the work table. NEVER grind on the top part of the wheel.
- 8. SIDE GRINDING.** Grinding on the side of some wheels can cause them to break and fly apart. Always check the wheel specifications before attempting side grinding operations.
- 9. HAND/WHEEL CONTACT.** Grinding wheels have the capability of removing a lot of skin fast. Keep a firm grip on the workpiece and position your hands a safe distance away when grinding. Avoid wearing gloves as they may get caught in the grinding wheel and cause serious entanglement injuries.
- 10. TABLE POSITION.** If the table is too far away from the wheel, the workpiece may be pulled down, causing loss of control and pulling your hand into the grinding wheel. Keep the table within 1/8" of the wheel when operating.

WARNING

Like all machinery there is potential danger when operating this machine. Accidents are frequently caused by lack of familiarity or failure to pay attention. Use this machine with respect and caution to lessen the possibility of operator injury. If normal safety precautions are overlooked or ignored, serious personal injury may occur.

CAUTION

No list of safety guidelines can be complete. Every shop environment is different. Always consider safety first, as it applies to your individual working conditions. Use this and other machinery with caution and respect. Failure to do so could result in serious personal injury, damage to equipment, or poor work results.



SECTION 2: CIRCUIT REQUIREMENTS

110V Operation

!WARNING

Serious personal injury could occur if you connect the machine to the power source before you have completed the set up process. **DO NOT** connect the machine to the power source until instructed to do so.



!WARNING
Electrocution or fire could result if this machine is not grounded correctly or if your electrical configuration does not comply with local and state codes. Ensure compliance by checking with a qualified electrician!

Amperage Draw

The Model H7762 motor draws the following amps under maximum load:

Motor Draw 6.3 Amps

Circuit Recommendations

We recommend connecting this machine to a dedicated circuit with a verified ground, using the circuit breaker size given below. Never replace a circuit breaker with one of higher amperage without consulting a qualified electrician to ensure compliance with wiring codes. **If you are unsure about the wiring codes in your area or you plan to connect your machine to a shared circuit, you may create a fire hazard—consult a qualified electrician to reduce this risk.**

Circuit Breaker 15 Amps

Plug/Receptacle Type

Included Plug Type NEMA 5-15

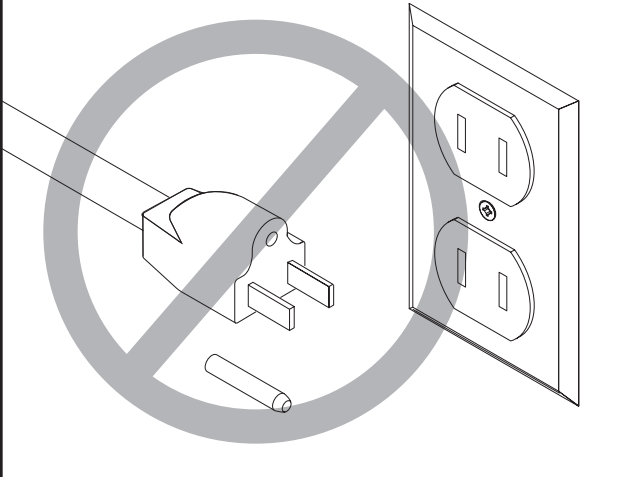

!CAUTION
This machine must have a ground prong in the plug to help ensure that it is grounded. **DO NOT** remove ground prong from plug to fit into a two-pronged outlet! If the plug will not fit the outlet, have the proper outlet installed by a qualified electrician.

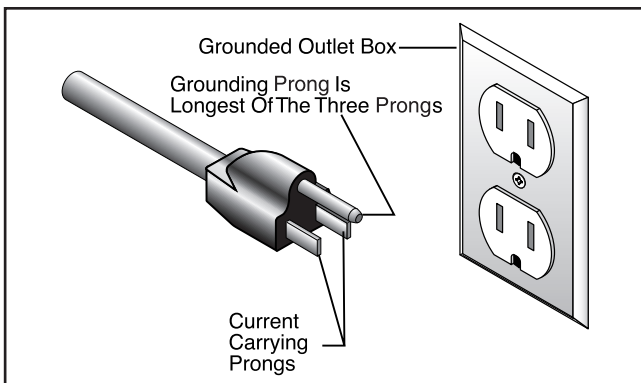

Figure 2. Typical type 5-15 plug and receptacle.

Extension Cords

We do not recommend the use of extension cords. If you find it absolutely necessary:

- Use at least a 16 gauge cord that does not exceed 50 feet in length!
- The extension cord must also contain a ground wire and plug pin.
- A qualified electrician **MUST** size cords over 50 feet long to prevent motor damage.



Inventory

After all the parts have been unpacked, you should have the following items:

Inventory (Figure 3)	Qty
A. Grinder Body	1
B. Shaft End Bushings.....	2
C. Work Table Angle Gauges.....	4
D. Work Table Lock Handles	4
E. Work Tables	2
F. Miter Gauge.....	1
G. Grinding Wheels (80 Grit)	2
H. Water Cup	1
I. Water Trays.....	2

Hardware and Tools

- Bolts M8-1.25 x 12
- Flat Washer 8mm.....
- Flat Washer 10mm.....
- Hex Nut M8-1.25
- Lock Washer 10mm

In the event that any nonproprietary parts are missing (e.g. a nut or a washer), we would be glad to replace them, or for the sake of expediency, replacements can be obtained at your local hardware store.

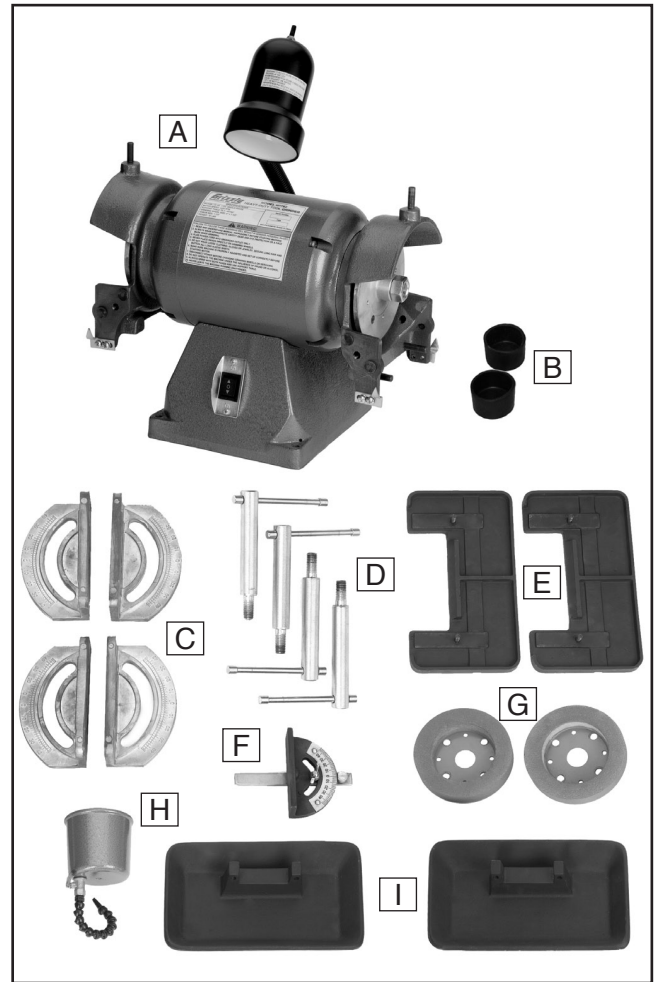













Figure 3. H7762 Inventory.



Hardware Recognition Chart

USE THIS CHART TO MATCH UP
HARDWARE DURING THE ASSEMBLY
PROCESS!

MEASURE BOLT DIAMETER BY PLACING INSIDE CIRCLE

-  #10
-  1/4"
-  5/16"
-  3/8"
-  7/16"
-  1/2"
-  4mm
-  6mm
-  8mm
-  10mm
-  12mm
-  16mm

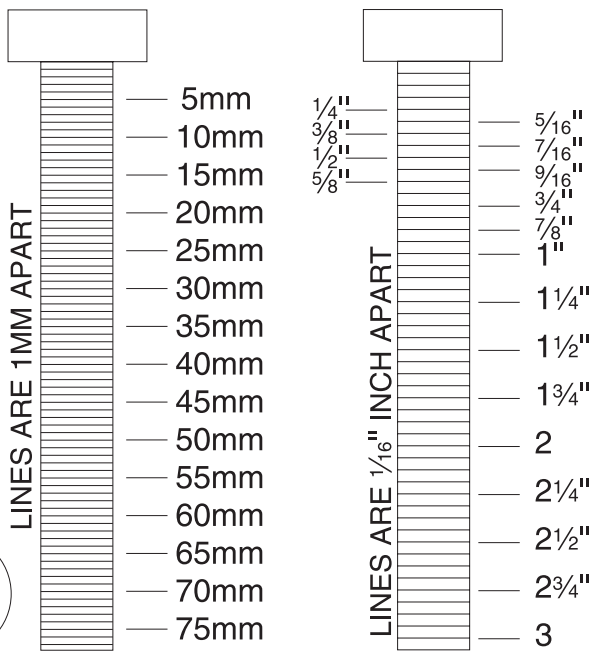
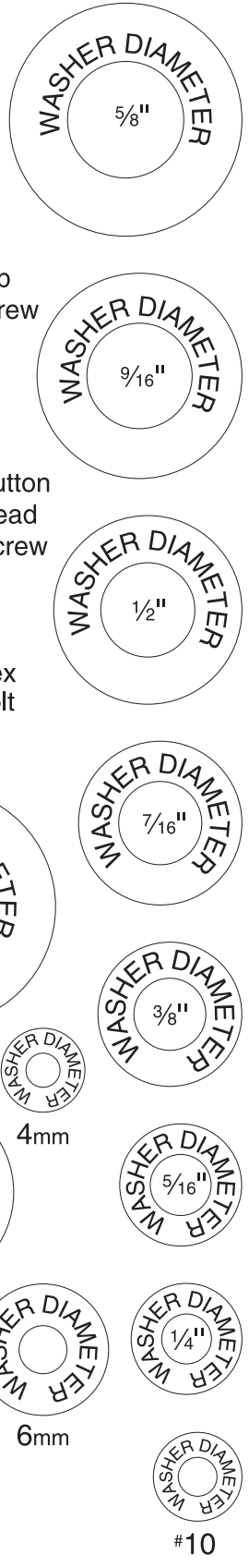
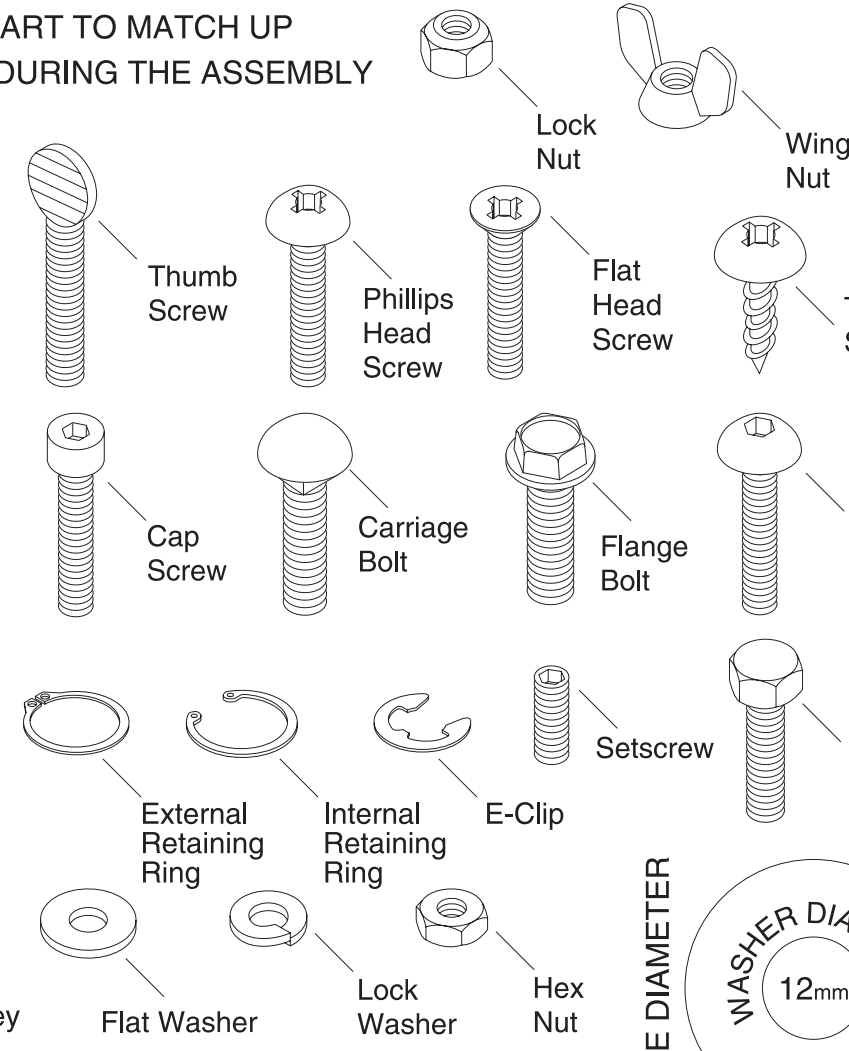

WASHERS ARE MEASURED BY THE INSIDE DIAMETER



Clean Up

The unpainted surfaces are coated with a waxy oil to protect them from corrosion during shipment. Remove this protective coating with a solvent cleaner or citrus-based degreaser such as Grizzly's G7895 Degreaser. To clean thoroughly, some parts may need to be removed. **For optimum performance from your machine, make sure you clean all moving parts or sliding contact surfaces that are coated.** Avoid chlorine-based solvents, such as acetone or brake parts cleaner, as they may damage painted surfaces should they come in contact. Always follow the manufacturer's instructions when using any type of cleaning product.

	<p>⚠ WARNING Gasoline and petroleum products have low flash points and could cause an explosion or fire if used to clean machinery. DO NOT use gasoline or petroleum products to clean the machinery.</p>
--	---

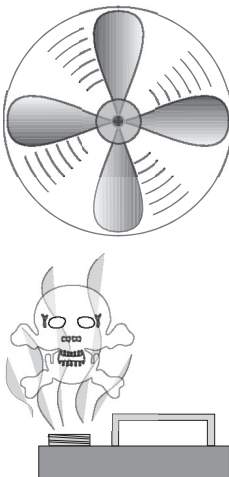
	<p>⚠ CAUTION Many of the solvents commonly used to clean machinery can be toxic when inhaled or ingested. Lack of ventilation while using these solvents could cause serious personal health risks or fire. Take precautions from this hazard by only using cleaning solvents in a well ventilated area.</p>
---	---

Site Considerations

Workbench Load

Refer to the **Machine Data Sheet** for the weight and footprint specifications of your machine. Some workbenches may require additional reinforcement to support the machine.

Working Clearances

Working clearances can be thought of as the distances between machines and obstacles that allow safe operation of every machine without limitation. Consider existing and anticipated machine needs, size of material to be processed through each machine, and space for auxiliary stands or work tables. Also consider the relative position of each machine to one another for efficient material handling.

Lighting and Outlets

Lighting should be bright enough to eliminate shadow and prevent eye strain. Electrical circuits should be dedicated or large enough to handle the amperage draw. Outlets should be located near each machine so power or extension cords are clear of high-traffic areas. Observe local electrical codes for proper installation of new lighting, outlets, or circuits.

	<p>⚠ CAUTION Unsupervised children and visitors inside your shop could cause serious personal injury to themselves. Lock all entrances to the shop when you are away and DO NOT allow unsupervised children or visitors in your shop at any time!</p>
--	---



Mounting

The Model H7762 weighs 92.5 lbs. Make sure the workbench on which you plan to mount the grinder is sturdy enough to hold the weight of the machine and any downward pressure that may be applied during operation. The workbench should have a level surface and be heavy, or attached to the floor so that it will not move or vibrate during operation.

Components and Hardware Required	Qty
Grinder Unit	1
Hex Bolt M8-1.25 (length varies).....	4
Flat Washer 8mm.....	8
Lock Washer 8mm	4
Hex Nut M8-1.25	4

Note: *Because sizes vary for each individual situation, the hardware in this step is not included with the Model H7762.*

Mount the grinder as shown below:

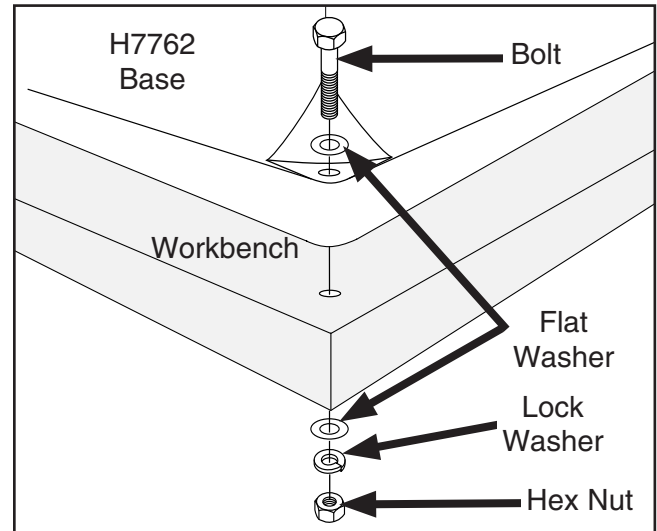

Figure 4. Mounting machine to the workbench.

Grinding Wheels

The Model H7762 features two Type 50 plate-mounted grinding wheels that must be attached to the grinder body before any operation of the machine.

Components and Hardware Required	Qty
Grinder Unit.....	1
Type 50 Plate-Mounted Grinding Wheels.....	2
Hex Bolts M6-1 x 25.....	8

To install the grinding wheels:

1. Remove the rubber shaft end bushing from the end of the arbor.
2. Carefully slide the grinding wheel onto the arbor. Be sure not to bump or scratch the wheel as it may dent, crack or otherwise damage the wheel.
3. Align the large holes in the grinding wheel with the large screw holes in the connection plate of the grinder.
4. Tightly fasten the wheel to the connector plate using the four hex bolts. In order to properly balance the wheel, tighten the bolts in the order shown in **Figure 5**.

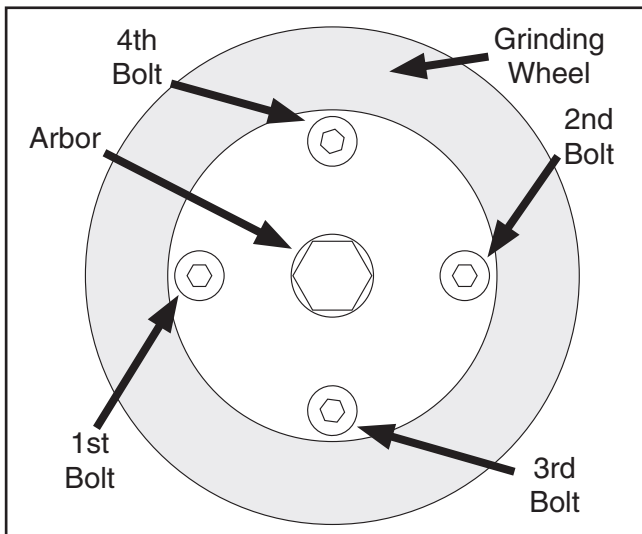

Figure 5. Wheel bolt mounting order.

5. Push the rubber shaft end bushing back onto the end of the arbor.
6. Repeat **Steps 1-6** for the second grinding wheel.

Work Tables

The Model H7762 also features two work tables that must be installed before any work can commence.

Components and Hardware Required	Qty
Grinder Unit.....	1
Work Table Angle Gauges.....	4
Lock Handles M10-1.25 x 23.....	4
Flat Washers 10mm.....	4
Lock Washers 10mm.....	4
Work Tables.....	2
Flat Washers 8mm.....	4
Hex Nuts M8-1.25.....	4

To install the work tables:

1. Attach an angle gauges to the grinder body with a 10mm washer, 10mm lock washer and lock handle as shown in **Figure 6**.

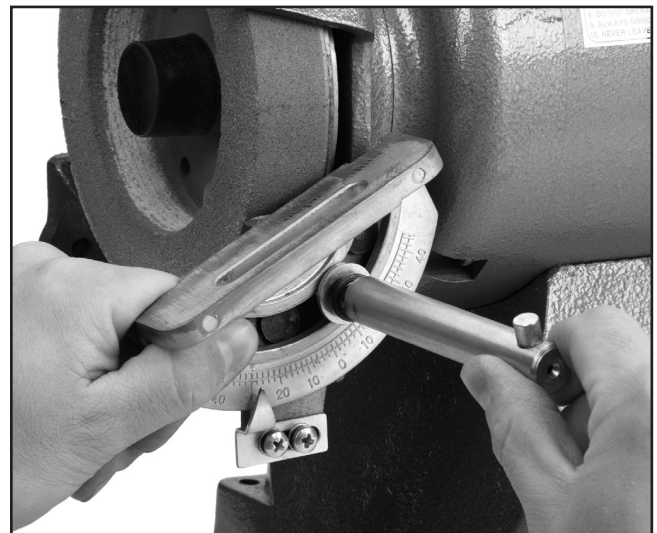

Figure 6. Attaching angle gauge.



2. Align the angle gauge so that the pointer at the bottom of the gauge is pointing at 0°.
3. Tighten the lock handle further so that the angle gauge does not move.
4. Repeat **Steps 1-3** for the other three angle gauges.
5. Place a work table on a pair of angle gauges so that the bolts on the underside of the table fit through the slots in the angle gauges.

6. Align the work table so the gap between the table and the grinding wheel is approximately $\frac{1}{8}$ ".
7. Fasten the table to the support dials using an 8mm flat washer and a hex nut on each bolt, as shown in **Figure 7**.

Note: *The fastening process can affect the gap between the work table and the grinding wheel. Always recheck the gap width after fastening and adjust as necessary.*

8. Repeat **Steps 5-7** for the other work table.

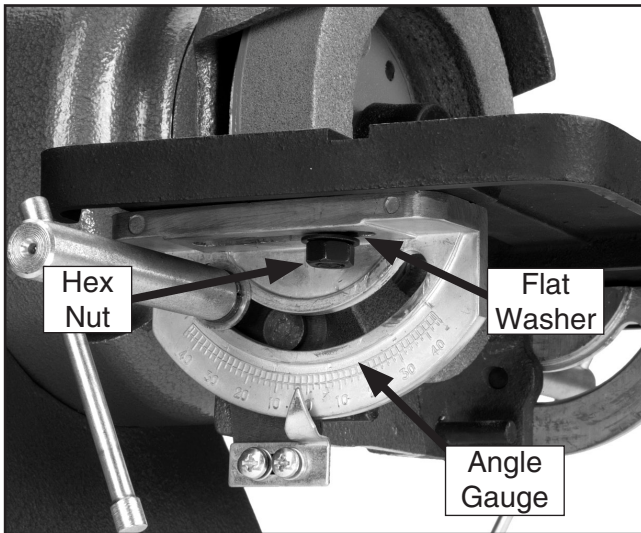
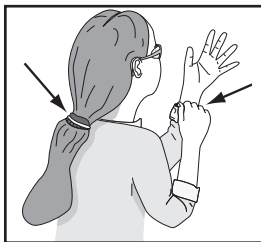

Figure 7. Work table attachment.

SECTION 4: OPERATION



!WARNING

Keep loose clothing rolled up and out of the way of machinery and keep hair pulled back.

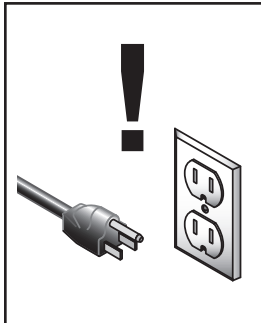

!WARNING

Disconnect power from the machine when performing any maintenance, assembly or adjustments. Failure to do this may result in serious personal injury.

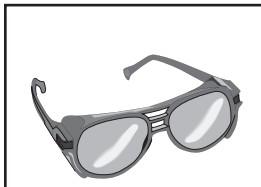

!WARNING

Using this machine produces dust which may cause eye injuries or respiratory problems. Protect yourself by wearing safety glasses and a respirator during the entire operation process. **DO NOT** wear gloves while operating this machine as they can be caught in the rotating surfaces and become entangled. Failure to comply with this warning may result in serious personal injury.

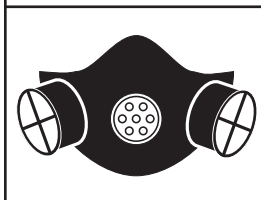

!WARNING

All grinding wheels have the potential of breaking apart during operation, causing serious personal injury or death! Always stand to the side of the grinder when turning it **ON** and wear the proper safety equipment to protect yourself.

Test Run

Once mounting and adjustments are complete as described in the previous section, you are ready to test the machine.

This grinder has a two-way switch. When switched to the "up" position (the top arrow on the switch), the grinder wheels will rotate upward and away from the front of the machine. When switched to the "down" position (the bottom arrow on the switch), the grinder wheels will rotate downward and towards the front of the machine. Both positions are considered the **ON** position. The central switch position (the circle on the switch) is the **OFF** position.

To test run the grinder:

1. Plug the machine into the power source.
2. Stand to the side of the grinder wheel and turn the grinder **ON**.

The machine should run smoothly with little or no vibration or rubbing noises. Strange or unusual noises should be investigated and corrected before operating the machine further. If the machine seems okay, stay out of the line of rotation of either grinding wheel and let it run for one to two minutes to make sure both wheels are structurally sound.

If you cannot easily locate the source of an unusual noise or vibration, feel free to contact our Technical Support department for help.

NOTICE

This section provides only a basic description of grinder applications. There are many different grinding wheels available for your grinder. **WE STRONGLY RECOMMEND** that you read books, trade magazines, or get formal training to maximize the potential of your machine.



Grinding Tips

The grinder is a safe tool when used properly. In addition to the safety instructions in this manual, the most important safety consideration is to use common sense at all times. What may be okay in one situation, may not be safe in another.

Read and understand the following statements to protect yourself before grinding:

- Make sure all guards are in place.
- Stand to the side of the grinder when you turn it **ON** and allow it to run for one full minute before beginning any grinding procedure.
- Make sure there are no loose mounting bolts and that you have performed the “Test Run” instructions in this manual.
- Remember that grinding often produces sparks. **DO NOT** allow anyone to stand in the path of the sparks. **DO NOT** grind near potentially flammable materials, such as flammable liquids or gases, paper or cloth.
- Wear the proper protective clothing. Remember that particles flying off of a grinding wheel will be traveling very fast—prepare for this. Wear a face shield, a dust mask and a leather apron.
- **DO NOT** lean into the workpiece in a manner that may cause your hands to move into the spinning wheel if the workpiece slips off.
- Concentrate on the task at hand. **STOP** grinding if there are distractions.

!WARNING

After you have switched OFF the grinder, DO NOT continue grinding and DO NOT manually stop the grinding wheel with your workpiece!

Operating Grinder

The grinder is designed for use with ferrous metals only. Grinding non-ferrous metals and wood products will quickly load the grinding wheel surface with particulate matter and ruin its abrasive qualities. It can also cause the wheel to overheat and possibly explode. Always grind on the surfaces shown in **Figure 8**.

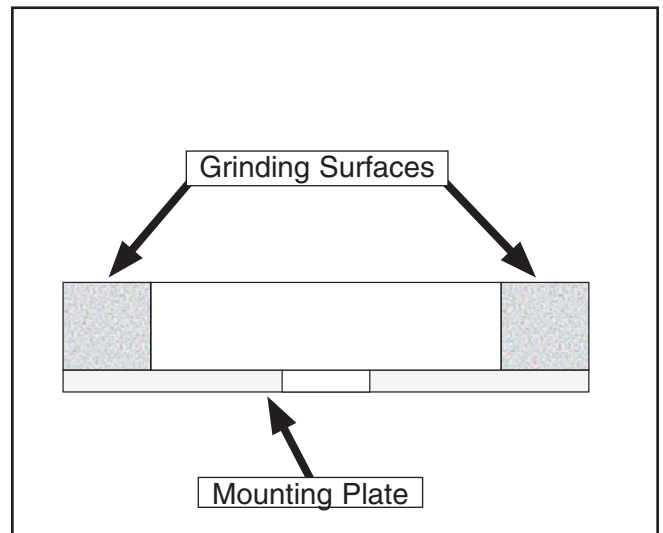

Figure 8. Type 50 grinding wheel surfaces.

To grind with the grinding wheel:

1. Fill the water cup $\frac{3}{4}$ full with water.
2. With the machine plugged into power, stand to the side of the grinding wheel, and turn the grinder **ON**.
3. Allow the machine to run for one full minute to ensure that the grinding wheels are safe for use, then move to the front of the machine.
4. Grasp the workpiece tightly and properly support it on the work table.
5. Place the workpiece against the surface of the wheel with moderate pressure, moving it back and forth in a steady, even motion.

Note: Using too much pressure will slow the motor, may damage the wheel, and will overheat the workpiece. Using too little pressure will prevent sufficient contact with the wheel.



6. Depending on the type of metal, you may need to regularly dip the workpiece into the water cup to cool it off. For heat-intensive work, direct a stream of water onto the workpiece and grinding wheel with the flexible water pipe. The flow of water can be increased or decreased using the red valve just below the water cup. If the water supply is exhausted, stop grinding and refill the water cup.

Wheel Care

A large part of your safety while grinding depends on the condition of the grinding wheel. A wheel in poor condition may break apart during rotation, causing serious injury.

To properly care for your wheel, follow these tips:

- Always transport, store and handle wheels with care. Wheels may be damaged if dropped or if heavy objects are stacked on them.
- Select the right grinding wheel for both the job and the machine. **DO NOT** grind material that is not designed for the wheel. A machine that rotates at a higher RPM than the wheel is rated for may cause the wheel to fly apart.
- Mount the wheels properly. (See the "Replacing Wheels" instructions on **Page 19** for guidance.) Never use a wheel with the wrong arbor size for the grinder.
- **DO NOT** abuse the wheel by jamming the workpiece into the grinding wheel with excessive force. This can cause irreparable damage to the wheel.
- Learn how to use the grinder and the grinding wheels properly. Ask a trusted person with experience or consult with your local library to learn more.
- Dress the grinding wheel when the surface loses its abrasive quality or becomes unbalanced.

Wheel Dressing

Dressing restores the grinding wheel with a like-new abrasive quality. Whenever the front surface of the wheel loses its abrasive qualities or balance due to particle loading or polishing of the wheel surface, then the wheel should be dressed. Use a commercially-available dressing tool, such as those available on **Page 21**.

To dress the grinding wheel:

1. With the machine plugged into power, stand to the side of the grinding wheel and move the switch to the **ON** position.
2. Allow the machine to run for at least one full minute to make sure that the grinding wheel is safe to use, then move to the front of the machine.
3. Hold the dressing tool firmly on the tool rest with both hands and press it lightly against the front surface of the grinding wheel.
4. Move the dressing tool in a side-to-side motion, while keeping it even with the surface of the grinding wheel.
5. Regularly pull the dressing tool away from the wheel for visual inspection and repeat **Steps 3 & 4** until the surface of the wheel appears to be restored to its normal color and balance.



Wheel Selection

The Model H7762 only accepts Type 50 wheels with a 1¼" bore.

Aluminum oxide and silicon carbide wheels are marked in a somewhat uniform manner by all major manufacturers. Understanding these markings will help you understand the capabilities of various wheels. Always refer to the manufacturer's grinding recommendations when selecting a wheel for your project.

The basic format for wheel numbering is:

Prefix	Abrasive Type	Grit Size	Grade Type	Bond Type
Type 1	A	60	L	V

The *Prefix* is the manufacturer's designation for a particular type.

The most common *Abrasive Types* used are A for Aluminum Oxide and C for Silicon Carbide, and occasionally SG for Seeded Gel.

The *Grit Size* is a number that refers to the size of the abrasive grain in the wheel. The lower the number, the coarser the wheel. Grit sizes range from 10, which is a very coarse grit used for roughing, to 220, which is usually the upper range for fine finish work.

Grade is an indication of the hardness of the wheel—"A" being the softest and "Z" being the hardest.

Bond Type refers to the type of bonding material used to hold the abrasive material. Most general purpose wheels will have a "V" indicating Vitrified Clay is used. Vitrified Clay provides high strength and good porosity. The other common bond type is "B" for resin where synthetic resins are used. These are used to grind cemented carbide and ceramic materials.

There may be other numbers inserted that have meaning for a particular type of wheel. Refer to the manufacturer's technical data for a complete explanation.

Wheel Inspection

Before mounting a new grinding wheel, it must be inspected. DO NOT assume that a wheel is in sound condition just because it is new—often, damage can occur during shipping, with age, or with exposure to moisture.

The most effective way to check for damage is to give the wheel a **Visual Inspection**. Look for any cracks, chips, nicks, or dents in the surface of the wheel. If you see any of these, however minor, DO NOT use the wheel. Ideally a new grinding wheel will be in almost flawless condition.

Replacing Wheels

WARNING

The hazards of using a damaged wheel include flying chunks of sharp abrasive material that could cause serious injury or death. Inspect every grinding wheel before it is mounted and DO NOT use a damaged grinding wheel!

The wheel guard assembly must be removed in order to mount or dismount a grinding wheel.

To remove/mount a wheel:

1. DISCONNECT MACHINE FROM THE POWER SUPPLY!
2. Remove the work table by unscrewing the two hex nuts on the underside of the table.
3. Unscrew the four bolts that fasten the grinding wheel to the connector plate.
4. Carefully slide the grinding wheel free from the arbor.

Continued on next page 



5. Slide the new grinding wheel onto the arbor. Be sure not to bump or scratch the wheel as it may dent, crack or otherwise damage the wheel.
6. Align the large holes in the grinding wheel with the screw holes in the connection plate of the grinder.
7. Fasten the wheel to the connector plate with the four bolts. In order to properly balance the wheel, tighten the bolts in the order shown in **Figure 9**.
8. Run a new wheel for at least one minute while standing clear of the line of rotation. If a wheel does have defects it will generally fail as soon as it gets up to full speed.

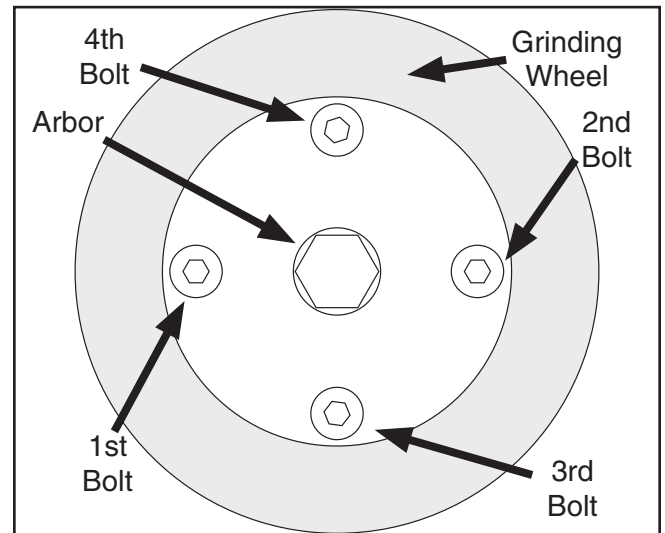

Figure 9. Wheel bolt mounting order.

SECTION 5: ACCESSORIES

- G7984—Face Shield
- H1298—Dust Sealed Safety Glasses
- H1300—UV Blocking, Clear Safety Glasses
- H2347—Uvex® Spitfire Safety Glasses
- H0736—Shop Fox® Safety Glasses

Safety Glasses are essential to every shop. If you already have a pair, buy extras for visitors or employees. You can't be too careful when it comes to shop safety!

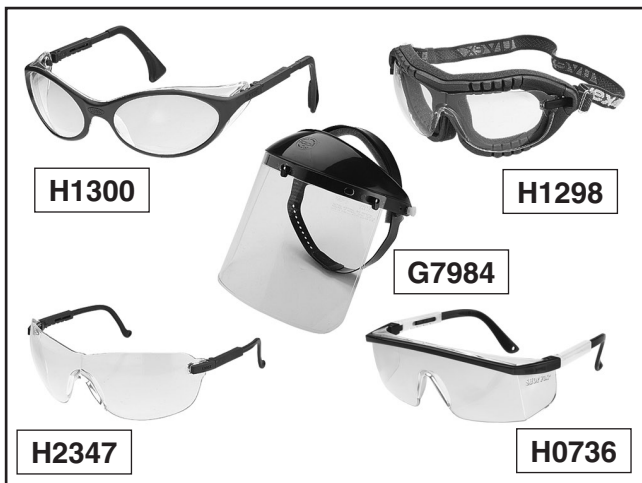

Figure 10. Our most popular safety glasses.

- H5891 1/4 Carat Diamond Dresser
- H5892 3/4 Carat Diamond Dresser

These 8 1/4" long round-body dressers feature industrial diamond tips and a knurled grip for maximum control. Includes protective rubber end cap. Available in two carat sizes.

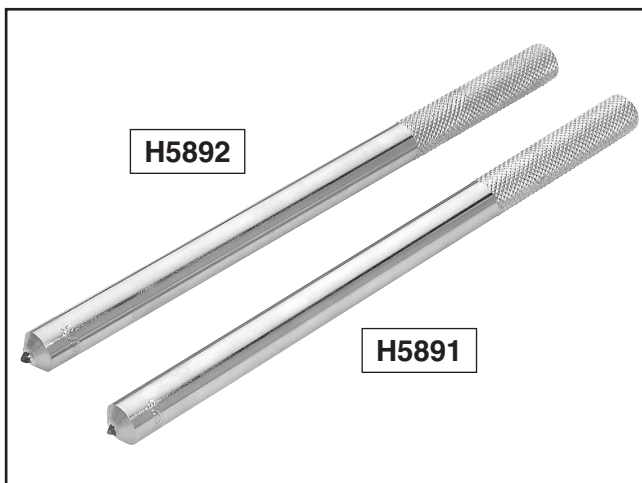

Figure 11. Our range of Diamond Dressers.

- H5944—#0 Wheel Dresser
- H5945—#1 Wheel Dresser
- H5946—#2 Wheel Dresser

These wheel dressers expose new grains for aggressive cutting on all types of grinding wheels. The star wheels and discs are hardened steel, and the cast iron handle provides stabilizing mass for better control. Available in three sizes: #0, #1 and #2.

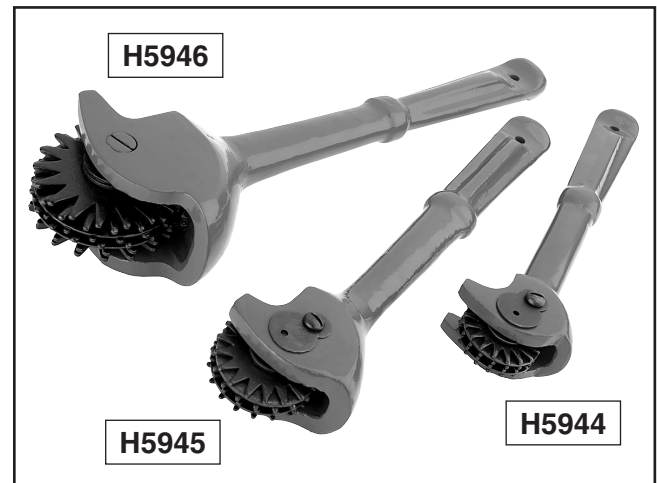
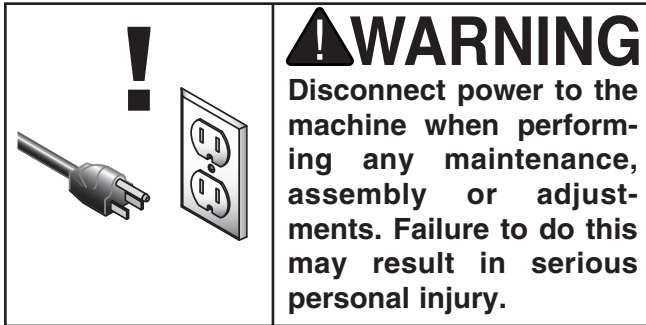

Figure 12. Our range of Wheel Dressers.

Call 1-800-523-4777 To Order

SECTION 6: MAINTENANCE



General

Always be aware of the condition of your machine. Routinely check the condition of the following items and repair or replace as necessary:

- Damaged or loose grinding wheels.
- Loose mounting bolts.
- Worn switch.
- Worn or damaged cord.
- Worn or damaged support bearings.
- Any other condition that could hamper the safe operation of this machine.

Lubrication

Sealed and pre-lubricated ball bearings require no lubrication for the life of the bearings. All bearings are standard sizes, and replacements can be purchased from our Parts Department or a bearing supply store.

Grinding Wheels

The grinding wheel should be visually inspected before every use. Take care in storing grinding wheels to keep them free from potential damage due to being dropped or having other items dropped on them. Store all grinding wheels in a dry location. Type 50 grinding wheels should be stored vertically with cushioning material between each wheel.

If a grinding wheel diameter has been reduced to 5", the wheel must be replaced. Operating a wheel at anything less than this diameter can lead to wheel explosion and serious personal injury.

Grinding wheels will require periodic dressing. Refer to the "Wheel Dressing" instructions on **Page 19** for details on how this is done.

SECTION 7: SERVICE

Review the troubleshooting and procedures in this section to fix your machine if a problem develops. If you need replacement parts or you are unsure of your repair skills, then feel free to call our Technical Support department at (570) 546-9663.

Troubleshooting

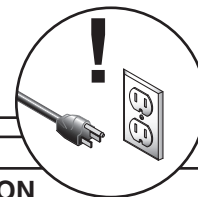

SYMPTOM	POSSIBLE CAUSE	CORRECTIVE ACTION
Motor will not start.	<ol style="list-style-type: none"> 1. Low voltage. 2. Open circuit in motor or loose connections. 	<ol style="list-style-type: none"> 1. Check power line voltage and correct if necessary. 2. Inspect all lead connections on motor for loose or open connections.
Motor will not start; fuses or circuit breakers blow.	<ol style="list-style-type: none"> 1. Loose connections or short circuit in line cord, plug or motor. 2. Incorrect fuses or circuit breakers in power line. 	<ol style="list-style-type: none"> 1. Inspect cord, plug and motor for damaged insulation, shorted wires or loose connections. 2. Install correct fuses or circuit breakers.
Motor overheats.	<ol style="list-style-type: none"> 1. Motor overloaded. 	<ol style="list-style-type: none"> 1. Reduce load on motor.
Motor stalls (resulting in blown fuses or tripped circuit).	<ol style="list-style-type: none"> 1. Motor overloaded. 2. Short circuit in motor or loose connections. 3. Low voltage. 4. Incorrect fuses or circuit breakers in power line. 	<ol style="list-style-type: none"> 1. Reduce load on motor. 2. Inspect connections on motor for loose or shorted terminals or worn insulation. 3. Check power line voltage and correct if necessary. 4. Install correct fuses or circuit breakers.
Machine slows when operating.	<ol style="list-style-type: none"> 1. Workpiece pressure is too great. 	<ol style="list-style-type: none"> 1. Reduce workpiece pressure on wheel.
Machine vibrates when operating.	<ol style="list-style-type: none"> 1. Grinding wheel is unbalanced. 2. Grinding wheel is cracked or damaged. 3. Arbor is bent. 4. Bearings are worn or damaged. 5. Mounting bolts are loose. 	<ol style="list-style-type: none"> 1. Adjust or tighten wheel mounting bolts as necessary. 1. Replace the wheel. 3. Inspect and replace the arbor if necessary. 4. Inspect and replace the bearings if necessary. 5. Tighten the mounting bolts.
Wavy condition on surface of workpiece.	<ol style="list-style-type: none"> 1. Machine vibrating. 2. Workpiece not being held firmly. 3. Wheel face uneven. 4. Wheel is too hard. 	<ol style="list-style-type: none"> 1. Ensure machine is securely mounted. 2. Use a holding device to firmly retain the workpiece. 3. Dress the grinding wheel. 4. Use softer wheel, or reduce the feed rate.
Lines on surface of workpiece.	<ol style="list-style-type: none"> 1. Impurity on wheel surface. 2. Workpiece not being held tightly. 	<ol style="list-style-type: none"> 1. Dress the grinding wheel. 2. Use a holding device to firmly retain the workpiece.
Burning spots or cracks in the workpiece.	<ol style="list-style-type: none"> 1. Workpiece pressure is too great. 2. Coolant required. 3. Improper type of grinding wheel. 	<ol style="list-style-type: none"> 1. Reduce workpiece pressure on wheel. 2. Cool the workpiece more frequently. 3. Try a wheel which is softer style or a coarser grit.
Wheel dulls quickly, grit falls off.	<ol style="list-style-type: none"> 1. Workpiece pressure is too great. 2. Wheel is too soft. 3. Wheel diameter too small. 4. Bad wheel dress. 5. Defective wheel bonding. 	<ol style="list-style-type: none"> 1. Reduce workpiece pressure on wheel. 2. Select a wheel with a harder bond. 3. Replace the wheel. 4. Dress the wheel. 5. Consult manufacturer of grinding wheel.
Wheel clogs and workpiece shows burn marks.	<ol style="list-style-type: none"> 1. Wheel is too hard. 2. Feed rate too slow. 3. Bad wheel dress. 4. Coolant required. 	<ol style="list-style-type: none"> 1. Select a wheel with a softer bond. 2. Increase rate of movement of workpiece onto wheel. 3. Dress the wheel. 4. Cool the workpiece more frequently.



Parts Breakdown

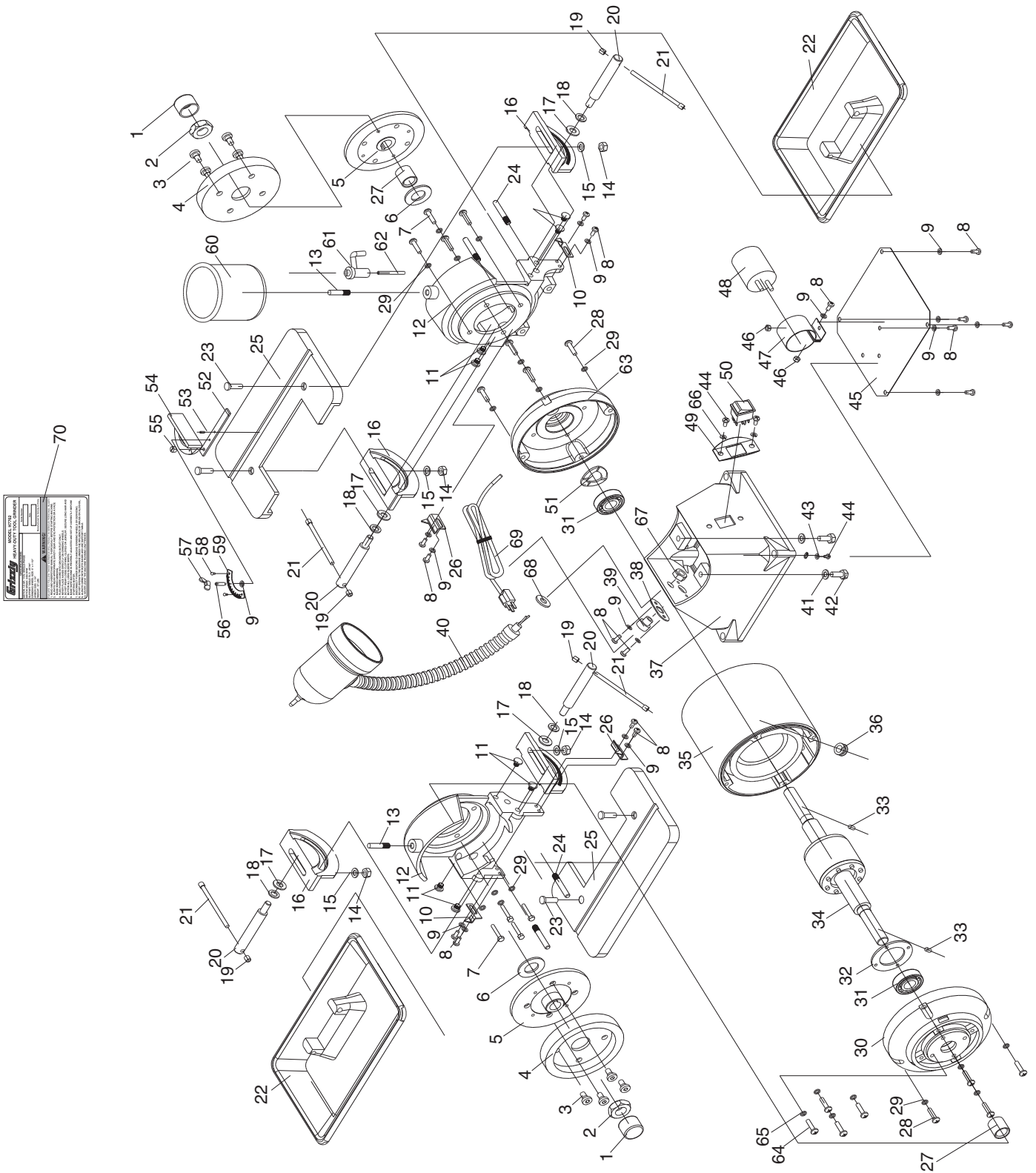

Parts List

REF	PART #	DESCRIPTION
1	PH7762001	SHAFT END BUSHING
2	PN15M	HEX NUT M18-1.5
3	PH7762003	SPECIAL SCREW M8-1.25 X 12
4	H8873	GRINDING WHEEL
5	PH7762005	CONNECTION PLATE
6	PH7762006	RUBBER WASHER
7	PB10M	HEX BOLT M6-1 X 25
8	PS09M	PHLP HD SCR M5-.8 X 10
9	PW02M	FLAT WASHER 5MM
10	PH7762010	LEFT-HAND POINTER
11	PH7762011	DIAL SET PIN
12	PH7762012	WHEEL COVER
13	PH7762013	WATER CUP SET PIN
14	PN03M	HEX NUT M8-1.25
15	PW01M	FLAT WASHER 8MM
16	PH7762016	ANGLE GAUGE
17	PW04M	FLAT WASHER 10MM
18	PLW06M	LOCK WASHER 10MM
19	PH7762019	HANDLE PIN BUSHING
20	PH7762020	LOCK HANDLE M10-1.5 X 23
21	PH7762021	LOCK HANDLE ARM
22	PH7762022	WATER TRAY
23	PH7762023	SUPT SCREW M8-1.25 X 18
24	PH7762024	WATER TRAY POSITIONING PIN
25	PH7762025	WORK SUPPORT
26	PH7762026	RIGHT-HAND POINTER
27	PH7762027	ADJUSTING BUSHING
28	PS47M	PHLP HD SCR M6-1 X 25
29	PLW03M	LOCK WASHER 6MM
30	PH7762030	LEFT MOTOR END CAP
31	P6204	BEARING 6204
32	PH7762032	BEARING FIXING RING
33	PH7762033	SPRING TYPE STRAIGHT PIN
34	PH7762034	ROTOR
35	PH7762035	STATOR

REF	PART #	DESCRIPTION
36	PH7762036	CORD BUSHING
37	PH7762037	MOTOR BASE
38	PH7762038	CORD CLIP FIXING PLATE
39	PH7762039	CORD CLIP
40	PH7762040	LAMP
41	PLW04M	LOCK WASHER 8MM
42	PB09M	HEX BOLT M8-1.25 X 20
43	PTLW11M	INTERNAL TOOTH WASHER 4MM
44	PS38M	PHLP HD SCR M4-.7 X 10
45	PH7762045	BOTTOM COVER
46	PN06M	HEX NUT M5-.8
47	PH7762047	CAPACITOR FIXING RING
48	PH7762048	CAPACITOR 50M 300VAC 3.75" X 2"
49	PH7762049	SWITCH FIXING PLATE
50	PH7762050	SWITCH
51	PH7762051	SPECIAL WAVE WASHER 35MM
52	PH7762052	MITER FIXING BRACKET
53	PH7762053	STRAIGHT PIN
54	PH7762054	MITER GAUGE
55	PH7762055	INDICATOR PIN
56	PH7762056	LOCKING BOLT M5-.8 X 13
57	PH7762057	WING NUT M5-.8
58	PH7762058	NAMEPLATE RIVET 2.5 X 4
59	PH7762059	SCALE PLATE
60	PH7762060	WATER CUP
61	PH7762061	VALVE
62	PH7762062	WATER PIPE
63	PH7762063	RIGHT MOTOR END CAP
64	PB104M	HEX BOLT M5-.8 X 30
65	PLW01M	LOCK WASHER 5MM
66	PLW02M	LOCK WASHER 4MM
67	PN22M	HEX NUT M12-1
68	PW06M	FLAT WASHER 12MM
69	PH7762069	CORD & PLUG
70	PH7762070	MACHINE ID LABEL

WARNING

Safety labels warn about machine hazards and ways to prevent injury. The owner of this machine **MUST** maintain the original location and readability of the labels on the machine. If any label is removed or becomes unreadable, **REPLACE** that label before using the machine again. Contact Grizzly at (800) 523-4777 or www.grizzly.com to order new labels.



WARRANTY AND RETURNS

Grizzly Industrial, Inc. warrants every product it sells for a period of **1 year** to the original purchaser from the date of purchase. This warranty does not apply to defects due directly or indirectly to misuse, abuse, negligence, accidents, repairs or alterations or lack of maintenance. This is Grizzly's sole written warranty and any and all warranties that may be implied by law, including any merchantability or fitness, for any particular purpose, are hereby limited to the duration of this written warranty. We do not warrant or represent that the merchandise complies with the provisions of any law or acts unless the manufacturer so warrants. In no event shall Grizzly's liability under this warranty exceed the purchase price paid for the product and any legal actions brought against Grizzly shall be tried in the State of Washington, County of Whatcom.

We shall in no event be liable for death, injuries to persons or property or for incidental, contingent, special, or consequential damages arising from the use of our products.

To take advantage of this warranty, contact us by mail or phone and give us all the details. We will then issue you a "Return Number," which must be clearly posted on the outside as well as the inside of the carton. We will not accept any item back without this number. Proof of purchase must accompany the merchandise.

The manufacturers reserve the right to change specifications at any time because they constantly strive to achieve better quality equipment. We make every effort to ensure that our products meet high quality and durability standards and we hope you never need to use this warranty.

Please feel free to write or call us if you have any questions about the machine or the manual.

Thank you again for your business and continued support. We hope to serve you again soon.





WARRANTY CARD

Name _____
 Street _____
 City _____ State _____ Zip _____
 Phone # _____ Email _____ Invoice # _____
 Model # _____ Order # _____ Serial # _____

The following information is given on a voluntary basis. It will be used for marketing purposes to help us develop better products and services. **Of course, all information is strictly confidential.**

1. How did you learn about us?

Advertisement Friend Catalog
 Card Deck Website Other:

2. Which of the following magazines do you subscribe to?

<input type="checkbox"/> Cabinet Maker	<input type="checkbox"/> Popular Mechanics	<input type="checkbox"/> Today's Homeowner
<input type="checkbox"/> Family Handyman	<input type="checkbox"/> Popular Science	<input type="checkbox"/> Wood
<input type="checkbox"/> Hand Loader	<input type="checkbox"/> Popular Woodworking	<input type="checkbox"/> Wooden Boat
<input type="checkbox"/> Handy	<input type="checkbox"/> Practical Homeowner	<input type="checkbox"/> Woodshop News
<input type="checkbox"/> Home Shop Machinist	<input type="checkbox"/> Precision Shooter	<input type="checkbox"/> Woodsmith
<input type="checkbox"/> Journal of Light Cont.	<input type="checkbox"/> Projects in Metal	<input type="checkbox"/> Woodwork
<input type="checkbox"/> Live Steam	<input type="checkbox"/> RC Modeler	<input type="checkbox"/> Woodworker West
<input type="checkbox"/> Model Airplane News	<input type="checkbox"/> Rifle	<input type="checkbox"/> Woodworker's Journal
<input type="checkbox"/> Modeltec	<input type="checkbox"/> Shop Notes	<input type="checkbox"/> Other:
<input type="checkbox"/> Old House Journal	<input type="checkbox"/> Shotgun News	

3. What is your annual household income?

\$20,000-\$29,000 \$30,000-\$39,000 \$40,000-\$49,000
 \$50,000-\$59,000 \$60,000-\$69,000 \$70,000+

4. What is your age group?

20-29 30-39 40-49
 50-59 60-69 70+

5. How long have you been a woodworker/metalworker?

0-2 Years 2-8 Years 8-20 Years 20+ Years

6. How many of your machines or tools are Grizzly?

0-2 3-5 6-9 10+

7. Do you think your machine represents a good value? Yes No

8. Would you recommend Grizzly Industrial to a friend? Yes No

9. Would you allow us to use your name as a reference for Grizzly customers in your area?
Note: We never use names more than 3 times. Yes No

10. Comments: _____

CUT ALONG DOTTED LINE

FOLD ALONG DOTTED LINE



Place
Stamp
Here



GRIZZLY INDUSTRIAL, INC.
P.O. BOX 2069
BELLINGHAM, WA 98227-2069



FOLD ALONG DOTTED LINE

Send a Grizzly Catalog to a friend:

Name _____
Street _____
City _____ State _____ Zip _____

TAPE ALONG EDGES--PLEASE DO NOT STAPLE

grizzly.com

TOOL WEBSITE

Buy Direct and Save with Grizzly® – Trusted, Proven and a Great Value!

*Visit Our Website Today And Discover
Why Grizzly® Is The Industry Leader!*

- SECURE ORDERING
- ORDERS SHIPPED WITHIN 24 HOURS
- E-MAIL RESPONSE WITHIN ONE HOUR

-OR-

Call Today For A **FREE**
Full Color Catalog

1-800-523-4777



Free Manuals Download Website

<http://myh66.com>

<http://usermanuals.us>

<http://www.somanuals.com>

<http://www.4manuals.cc>

<http://www.manual-lib.com>

<http://www.404manual.com>

<http://www.luxmanual.com>

<http://aubethermostatmanual.com>

Golf course search by state

<http://golfingnear.com>

Email search by domain

<http://emailbydomain.com>

Auto manuals search

<http://auto.somanuals.com>

TV manuals search

<http://tv.somanuals.com>