

Grizzly
Industrial, Inc. ®

12" X 35½" WOOD LATHE
MODEL G5979
INSTRUCTION MANUAL



COPYRIGHT © FEBRUARY, 2002 BY GRIZZLY INDUSTRIAL, INC.
**WARNING: NO PORTION OF THIS MANUAL MAY BE REPRODUCED IN ANY SHAPE
OR FORM WITHOUT THE WRITTEN APPROVAL OF GRIZZLY INDUSTRIAL, INC.**
PRINTED IN CHINA.

WARNING

Some dust created by power sanding, sawing, grinding, drilling, and other construction activities contains chemicals known to the State of California to cause cancer, birth defects or other reproductive harm. Some examples of these chemicals are:

- Lead from lead-based paints.
- Crystalline silica from bricks, cement, and other masonry products.
- Arsenic and chromium from chemically treated lumber.

Your risk from these exposures varies, depending on how often you do this type of work. To reduce your exposure to these chemicals: work in a well ventilated area, and work with approved safety equipment, such as those dust masks that are specially designed to filter out microscopic particles.

Table Of Contents

	PAGE
1. SAFETY	
SAFETY RULES FOR ALL TOOLS	2-3
ADDITIONAL SAFETY INSTRUCTIONS FOR G5979	4
2. CIRCUIT REQUIREMENTS	
110V OPERATION	5
GROUNDING	5
EXTENSION CORDS	5
3. INTRODUCTION	
COMMENTARY	6
UNPACKING	7
PIECE INVENTORY	8
HARDWARE RECOGNITION	9
CLEAN UP	10
SITE CONSIDERATIONS	10
4. ASSEMBLY	
BEGINNING ASSEMBLY	11
STAND.....	11
LATHE TO STAND	12
FLOOR MOUNTING	12
HEADSTOCK LOCK	13
SPUR CENTER.....	13
FACEPLATE	14
EXTENSION BED	14
5. ADJUSTMENTS	
HEADSTOCK	15
TAILSTOCK.....	15
TOOL REST	16
6. OPERATIONS	
TEST RUN.....	17
SPEED SELECTOR	17
SPINDLE TURNING	18
FACEPLATE TURNING	19
TOOL REST	19
7. MAINTENANCE	
GENERAL	20
RUST	20
LUBRICATION.....	20
V-BELT	20
DUST/CHIP REMOVAL.....	20
8. CLOSURE	21
MACHINE DATA	22
PARTS BREAKDOWN AND PARTS LISTS	23-25
WARRANTY AND RETURNS	26

SECTION 1: SAFETY

WARNING

For Your Own Safety Read Instruction Manual Before Operating This Equipment

The purpose of safety symbols is to attract your attention to possible hazardous conditions. This manual uses a series of symbols and signal words which are intended to convey the level of importance of the safety messages. The progression of symbols is described below. Remember that safety messages by themselves do not eliminate danger and are not a substitute for proper accident prevention measures.



Indicates an imminently hazardous situation which, if not avoided, **WILL** result in death or serious injury.



Indicates a potentially hazardous situation which, if not avoided, **COULD** result in death or serious injury.



Indicates a potentially hazardous situation which, if not avoided, **MAY** result in minor or moderate injury. It may also be used to alert against unsafe practices.

NOTICE

This symbol is used to alert the user to useful information about proper operation of the equipment.

WARNING

Safety Instructions For Power Tools

1. **KEEP GUARDS IN PLACE** and in working order.
2. **REMOVE ADJUSTING KEYS AND WRENCHES.** Form habit of checking to see that keys and adjusting wrenches are removed from tool before turning on.
3. **KEEP WORK AREA CLEAN.** Cluttered areas and benches invite accidents.
4. **DO NOT USE IN DANGEROUS ENVIRONMENT.** Do not use power tools in damp or wet locations, or where any flammable or noxious fumes may exist. Keep work area well lighted.
5. **KEEP CHILDREN AND VISITORS AWAY.** All children and visitors should be kept a safe distance from work area.
6. **MAKE WORKSHOP CHILD PROOF** with padlocks, master switches, or by removing starter keys.
7. **DO NOT FORCE TOOL.** It will do the job better and safer at the rate for which it was designed.
8. **USE RIGHT TOOL.** Do not force tool or attachment to do a job for which it was not designed.

WARNING

Safety Instructions For Power Tools

- 9. USE PROPER EXTENSION CORD.** Make sure your extension cord is in good condition. Conductor size should be in accordance with the chart below. The amperage rating should be listed on the motor or tool nameplate. An undersized cord will cause a drop in line voltage resulting in loss of power and overheating. Your extension cord must also contain a ground wire and plug pin. Always repair or replace extension cords if they become damaged.

Minimum Gauge for Extension Cords

AMP RATING	LENGTH		
	25ft	50ft	100ft
0-6	18	16	16
7-10	18	16	14
11-12	16	16	14
13-16	14	12	12
17-20	12	12	10
21-30	10	10	No

- 10. WEAR PROPER APPAREL.** Do not wear loose clothing, gloves, neckties, rings, bracelets, or other jewelry which may get caught in moving parts. Non-slip footwear is recommended. Wear protective hair covering to contain long hair.
- 11. ALWAYS USE SAFETY GLASSES.** Also use face or dust mask if cutting operation is dusty. Everyday eyeglasses only have impact resistant lenses, they are NOT safety glasses.
- 12. SECURE WORK.** Use clamps or a vise to hold work when practical. It's safer than using your hand and frees both hands to operate tool.
- 13. DO NOT OVER-REACH.** Keep proper footing and balance at all times.
- 14. MAINTAIN TOOLS WITH CARE.** Keep tools sharp and clean for best and safest performance. Follow instructions for lubricating and changing accessories.
- 15. USE RECOMMENDED ACCESSORIES.** Consult the owner's manual for recommended accessories. The use of improper accessories may cause risk of injury.
- 16. REDUCE THE RISK OF UNINTENTIONAL STARTING.** On machines with magnetic contact starting switches there is a risk of starting if the machine is bumped or jarred. Always disconnect from power source before adjusting or servicing. Make sure switch is in OFF position before reconnecting.
- 17. MANY WOODWORKING TOOLS CAN "KICKBACK" THE WORKPIECE** toward the operator if not handled properly. Know what conditions can create "kickback" and know how to avoid them. Read the manual accompanying the machine thoroughly.
- 18. CHECK DAMAGED PARTS.** Before further use of the tool, a guard or other part that is damaged should be carefully checked to determine that it will operate properly and perform its intended function. Check for alignment of moving parts, binding of moving parts, breakage of parts, mounting, and any other conditions that may affect its operation. A guard or other part that is damaged should be properly repaired or replaced.
- 19. NEVER LEAVE TOOL RUNNING UNATTENDED. TURN POWER OFF.** Do not leave tool until it comes to a complete stop.
- 20. NEVER OPERATE A MACHINE WHEN TIRED, OR UNDER THE INFLUENCE OF DRUGS OR ALCOHOL.** Full mental alertness is required at all times when running a machine.
- 21. NEVER ALLOW UNSUPERVISED OR UNTRAINED PERSONNEL TO OPERATE THE MACHINE.** Make sure any instructions you give in regards to machine operation are approved, correct, safe, and clearly understood.
- 22. IF AT ANY TIME YOU ARE EXPERIENCING DIFFICULTIES** performing the intended operation, stop using the machine! Then contact our service department or ask a qualified expert how the operation should be performed.

WARNING

Additional Safety Instructions For The Lathe

1. **MAKE SURE ALL GUARDS** are in place and that the Lathe sits on a flat, stable surface.
2. **ALWAYS WEAR EYE PROTECTION** or a face shield when operating the Lathe. All safety equipment should be ANSI approved.
3. **USE A RESPIRATOR TO AVOID INHAILING DUST.** All safety equipment should be ANSI approved.
4. **BEFORE STARTING THE MACHINE** be certain the workpiece has been properly imbedded on the headstock and tailstock centers and that there is adequate clearance for the full rotation.
5. **ADJUST TOOL REST** to provide proper support for the turning tool you will be using. Test tool rest clearance by rotating workpiece by hand before turning lathe on.
6. **SELECT THE TURNING SPEED** which is appropriate for the type of work. Allow the lathe to gain its full speed before using.
7. **ALWAYS INSPECT THE CONDITION** of the materials you are turning. Do not turn pieces with knots, splits and other potentially dangerous conditions.
8. **KEEP LATHE TOOLS PROPERLY SHARPENED** and hold firmly in the proper position when turning.
9. **NEVER OPERATE THE LATHE WITH DAMAGED OR WORN PARTS.** Maintain your lathe in proper working condition. Perform routine inspections and maintenance promptly when called for. Put away adjustment tools after use.
10. **MAKE SURE YOUR WOOD LATHE IS TURNED OFF,** disconnected from its power source and all moving parts have come to a complete stop before starting any inspection, adjustment, or maintenance procedure.
11. **DO NOT LEAVE LATHE RUNNING UNATTENDED** for any reason.
12. **DO NOT STOP LATHE USING YOUR HAND** against the workpiece.
13. **KEEP LOOSE CLOTHING ARTICLES** such as sleeves, belts and jewelry items away from the lathe spindle.
14. **WHEN FACE PLATE TURNING,** use lathe chisels on the downward spinning side of the workpiece only.
15. **REMOVE THE TOOL REST** when performing sanding or polishing operations on the rotating spindle.
16. **ATTEMPTING TO REMOVE** too much material at once may cause work material to fly out of the lathe.

CAUTION

No list of safety guidelines can be complete. Every shop environment is different. Always consider safety first, as it applies to your individual working conditions. Use this and other machinery with caution and respect. Failure to do so could result in serious personal injury, damage to equipment or poor work results.

SECTION 2: CIRCUIT REQUIREMENTS

110V Operation

The Model G5979 is wired for 110V operation only. The ½ H.P. motor will safely draw 4 amps at 110V. If you operate this machine on any circuit that is already close to its capacity, it might blow a fuse or trip a circuit breaker. However, if an unusual load does not exist and a power failure still occurs, contact a qualified electrician or our service department.

A 15 amp dedicated circuit should be used with this wood lathe. Always check to see if your current wires are capable of handling a 4 amp load. If you are unsure, consult the advice of a qualified electrician.



Extension Cords

If you find it necessary to use an extension cord with the Model G5979, make sure the cord is rated Hard Service (grade S) or better. Refer to the chart in the standard safety instructions to determine the minimum gauge for the extension cord. The extension cord must also contain a ground wire and plug pin. Always repair or replace extension cords when they become worn or damaged.



Grounding

In the event of an electrical short, grounding reduces the risk of electric shock by providing electric current a path of least resistance. This tool is equipped with a power cord having an equipment-grounding conductor as shown in **Figure 1B**. The outlet must be properly installed and grounded in accordance with all local codes and ordinances.

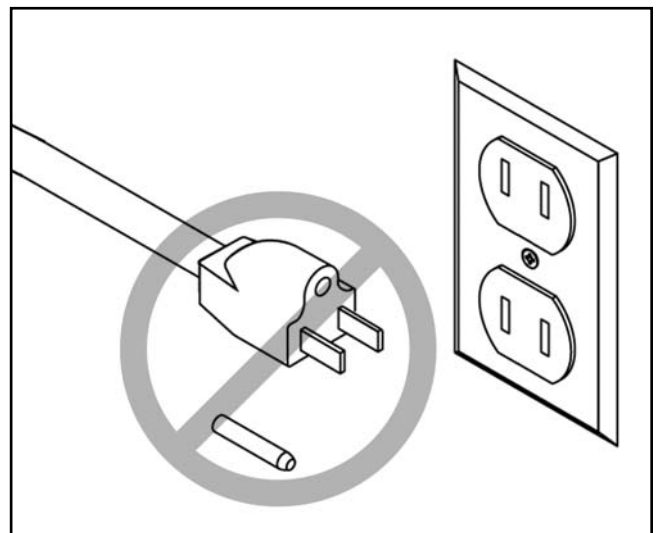
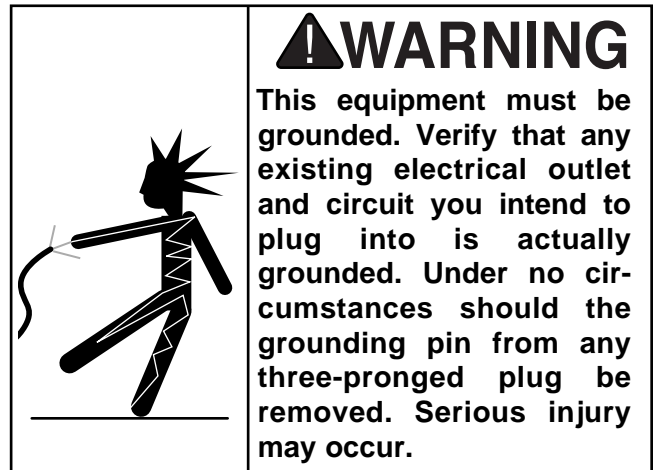

Figure 1A. Do not remove grounding pin.

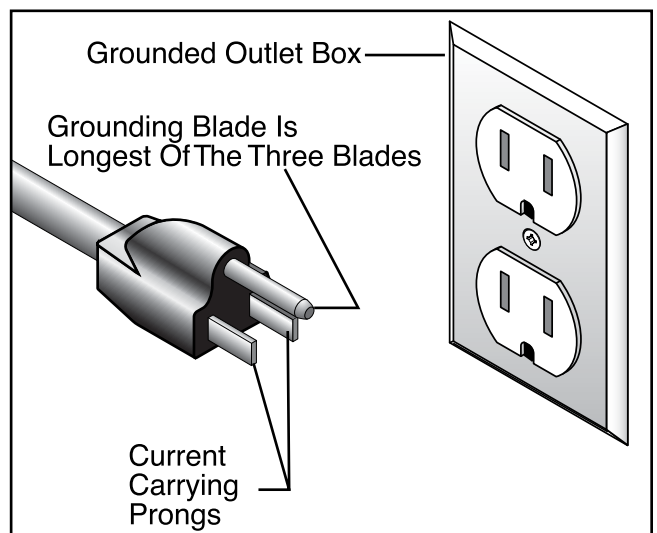

Figure 1B. Typical 110V plug and outlet.



SECTION 3: INTRODUCTION

Commentary

We are proud to offer the Grizzly Model G5979 Wood Lathe. The Model G5979 is part of a growing Grizzly family of fine woodworking machinery. When used according to the guidelines set forth in this manual, you can expect years of trouble-free, enjoyable operation and proof of Grizzly's commitment to customer satisfaction.

The Model G5979 is a 10 speed, swivel-head wood lathe capable of a wide variety of turning operations. This lathe also features a cast iron bed, outboard tool rest, quick-release head and tailstock, 12" swing over bed, 35½" between centers, 6" faceplate and #2 Morse Taper.

A number of chisels, gouges, faceplates and accessories for the Model G5979 are available through the Grizzly catalog.

We are also pleased to provide this manual with the Model G5979. It was written to guide you through assembly, review safety considerations, and cover general operating procedures. It represents our effort to produce the best documentation possible. If you have any comments regarding this manual, please write to us at the address below:

Grizzly Industrial, Inc.
% Technical Documentation
P.O. Box 2069
Bellingham, WA 98227-2069

Most importantly, we stand behind our machines. If you have any service questions or parts requests, please call or write us at the location listed below.

Grizzly Industrial, Inc.
1203 Lycoming Mall Circle
Muncy, PA 17756
Phone: (570) 546-9663
Fax: (800) 438-5901
E-Mail: techsupport@grizzly.com
Web Site: <http://www.grizzly.com>

The specifications, drawings, and photographs illustrated in this manual represent the Model G5979 as supplied when the manual was prepared. However, owing to Grizzly's policy of continuous improvement, changes may be made at any time with no obligation on the part of Grizzly. Whenever possible, though, we send manual updates to all owners of a particular tool or machine. Should you receive one, we urge you to insert the new information with the old and keep it for reference.

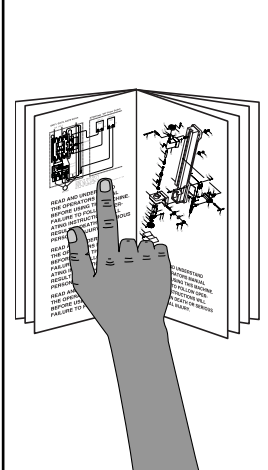
	<p>!WARNING</p> <p>Read the manual before assembly and operation. Become familiar with the machine and its operation before beginning any work. Serious personal injury may result if safety or operational information is not understood or followed.</p>
--	--



Unpacking

The Model G5979 is shipped from the manufacturer in a carefully packed carton. If you discover the machine is damaged after you've signed for delivery, immediately call Customer Service for advice.

When you are completely satisfied with the condition of your shipment, you should inventory its parts in the next section.

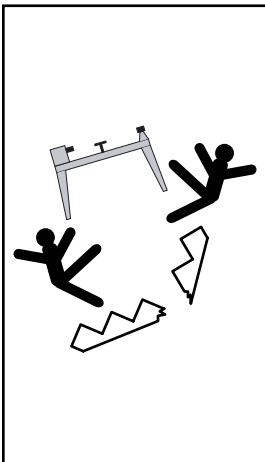
	<p>! WARNING</p> <p>If moving this machine up or down stairs, the machine must be dismantled and moved in smaller pieces. Make sure floor and stair structures are capable of supporting the combined weight of the machine parts and the people moving them.</p>
--	--

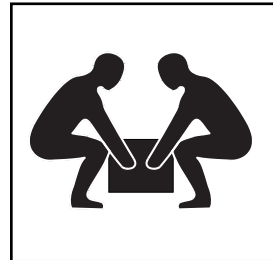
	<p>! CAUTION</p> <p>The G5979 represents a load of 190 pounds. Seek assistance before beginning assembly.</p>
--	--

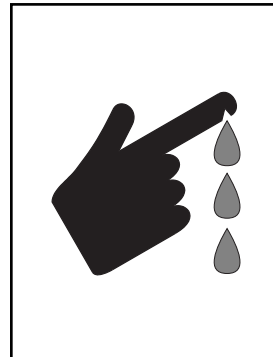
	<p>! CAUTION</p> <p>Some metal parts may have sharp edges on them after they are formed. Please examine the edges of all metal parts before handling them. Failure to do so could result in injury.</p>
--	--



Piece Inventory

After all the parts have been removed from the carton, you should have:

- Lathe Unit
- Extension Bed
- Rear Legs (2)
- Front Legs (2)
- Long Leg Supports (2)
- Top Leg Plates (2)
- 4" Faceplate
- Live Center
- Spur Center
- Lock Handle
- Headstock Lock Handle
(w/Spring and Cap Screw)
- 3, 4, 6 and 8mm Allen® Wrenches
- Push Rod
- 32mm Open End Wrench (2)
- Hardware Bag
 - M8-1.25 x 10 Carriage Bolts (24)
 - M8-1.25 Hex Bolts (32)
 - M8 Flat Washer (24)
 - M8-1.25 x 35 Cap Screws (8)
 - M8 Lock Washers (8)
 - M10-1.5 x 25 Cap Screws (2)
 - M10 Lock Washers (2)

In the event that any nonproprietary parts are missing (e.g. a nut or a washer), we would be glad to replace them, or for the sake of expediency, replacements can be obtained at your local hardware store.

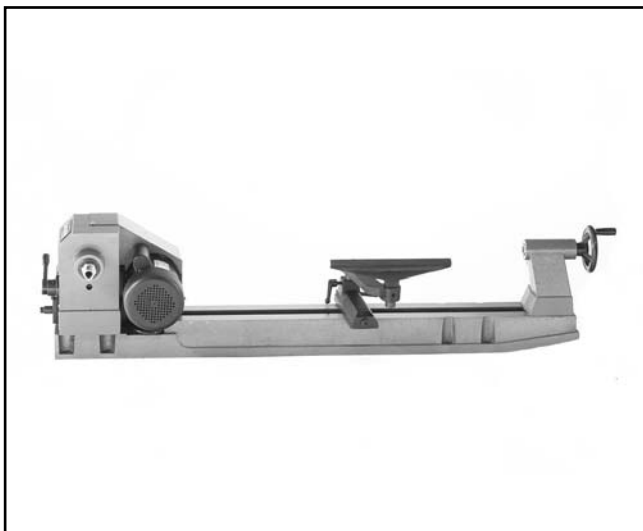

Figure 2. Lathe unit.

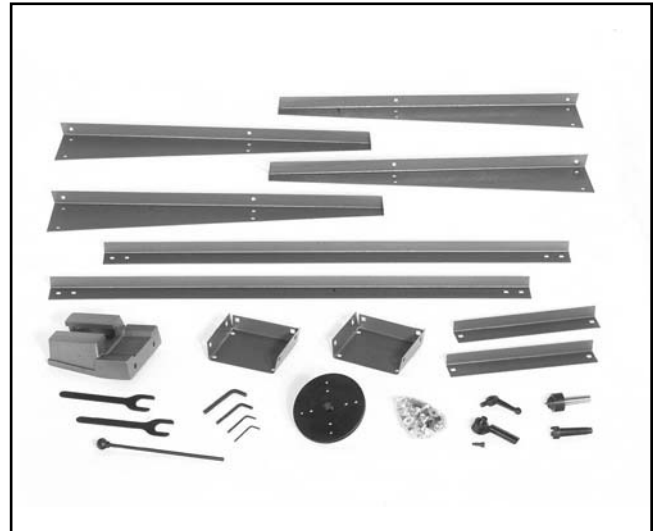

Figure 3. Parts layout.

NOTICE













A full parts list and breakdown can be found toward the end of this manual. For easier assembly, or to identify specific parts, please refer to the detailed illustrations at the end of the manual.



Hardware Recognition Chart

Use this chart to match up hardware pieces during the assembly process!

MEASURE BOLT DIAMETER BY PLACING INSIDE CIRCLE

-  #10
-  1/4"
-  5/16"
-  3/8"
-  7/16"
-  1/2"
-  5/8"
-  4mm
-  6mm
-  8mm
-  10mm
-  12mm
-  16mm

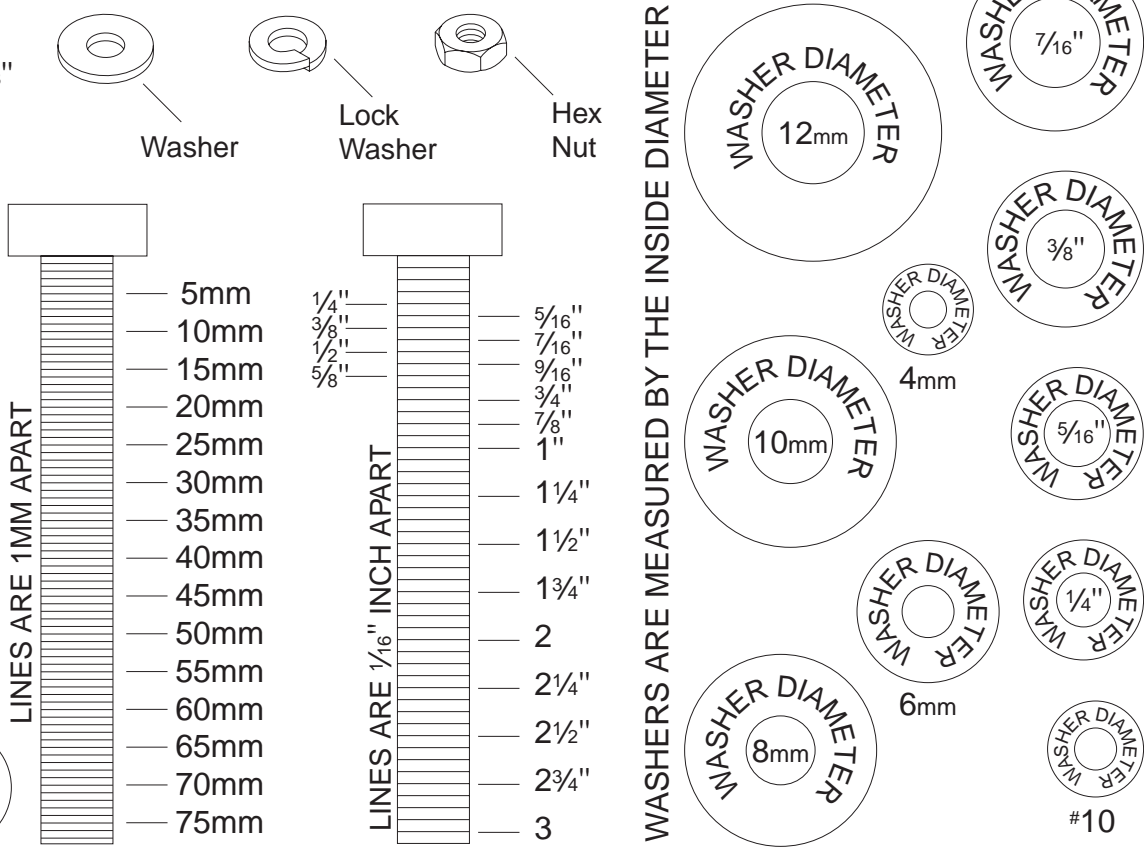
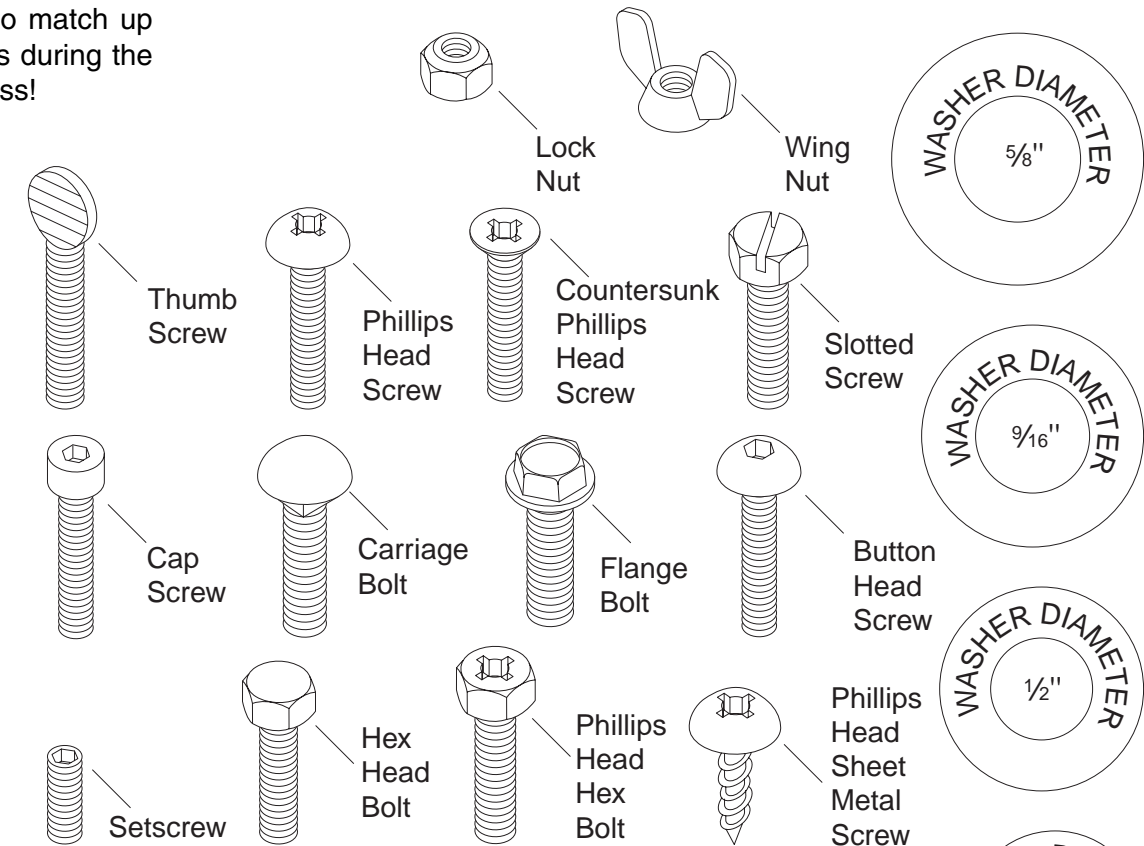

WASHERS ARE MEASURED BY THE INSIDE DIAMETER

Clean Up

The unpainted surfaces are coated with a waxy oil to protect them from corrosion during shipment. Remove this protective coating with a solvent cleaner or citrus-based degreaser such as Grizzly's G7895 Degreaser. Avoid chlorine-based solvents as they may damage painted surfaces should they come in contact. Always follow the usage instructions on the product you choose for clean up.

	<p>⚠️ WARNING Do not use gasoline or other petroleum-based solvents. They have low flash points which make them extremely flammable. A risk of explosion and burning exists if these products are used. Serious personal injury may occur if this warning is ignored.</p>
--	--

	<p>⚠️ WARNING Do not smoke while using solvents. A risk of explosion or fire exists and may result in serious personal injury.</p>
---	---

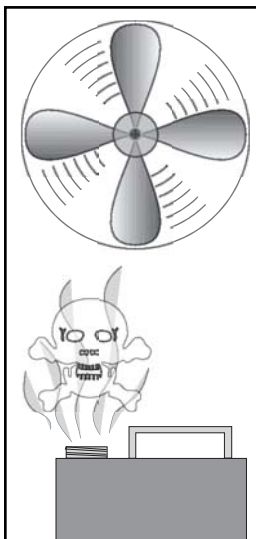
	<p>⚠️ CAUTION Many of the solvents commonly used to clean machinery can be toxic when inhaled or ingested. Always work in well-ventilated areas far from potential ignition sources when dealing with solvents. Use care when disposing of waste rags and towels to be sure they do not create fire or environmental hazards.</p>
---	--



Site Considerations

FLOOR LOAD

Your Model G5979 represents a moderate weight load in a small footprint. Most commercial or home shop floors should be sufficient to carry the weight of the Model G5979. If you question the strength of your floor, you can opt to reinforce it. Ensure that the stand or bench you use with the Model G5979 is capable of supporting the machine.

WORKING CLEARANCES

Working clearances can be thought of as the distances between machines and obstacles that allow safe operation of every machine without limitation. Consider existing and anticipated machine needs, size of material to be processed through each machine, and space for auxiliary stands and/or work tables. Also, consider the relative position of each machine to one another for efficient material handling. Be sure to allow yourself sufficient room to safely run your machines in any foreseeable operation and keep dust collection hoses off the floor and out of the way.

LIGHTING AND OUTLETS

Lighting should be bright enough to eliminate shadows and prevent eye strain. Electrical circuits should be dedicated or large enough to handle combined motor amp loads. Outlets should be located near each machine so power or extension cords are not obstructing high-traffic areas. Be sure to observe local electrical codes for proper installation of new lighting, outlets, or circuits.

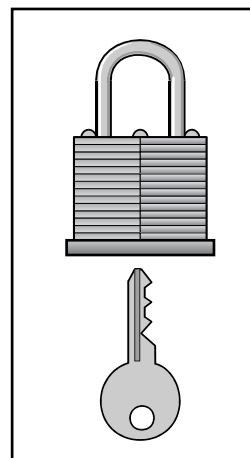
	<p>⚠️ CAUTION Make your shop "child safe." Ensure that your workplace is inaccessible to youngsters by closing and locking all entrances when you are away. Never allow visitors in your shop when assembling, adjusting or operating equipment.</p>
--	---



SECTION 4: ASSEMBLY

Beginning Assembly

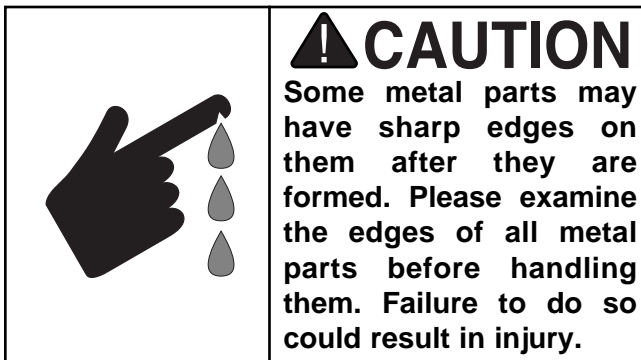
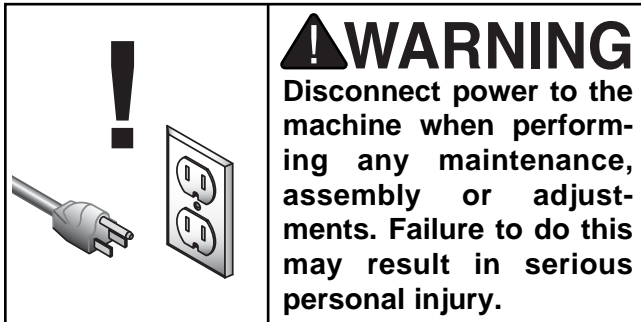

Most of your Model G5979 has been assembled at the factory, but some parts must be assembled or installed after delivery. We have organized the assembly process into steps. Please follow along in the order presented here.

TOOLS REQUIRED: Metric hex key set, adjustable wrench, Phillips and flat screwdriver.



G5979 Wood Lathe

Stand

1. Attach a front and rear vertical leg to the top plate using the $\frac{1}{4}$ "-20 x $\frac{3}{8}$ " carriage bolts, $\frac{1}{4}$ " flat washers and $\frac{1}{4}$ " nuts. Position the top plate so that it fits inside the legs.
2. Repeat the previous step with the other two vertical legs.
3. Attach the two long horizontal supports to each of the vertical leg assemblies using the $\frac{1}{4}$ "-20 x $\frac{3}{8}$ " carriage bolts, $\frac{1}{4}$ " flat washers and $\frac{1}{4}$ " nuts.
4. Attach the two short horizontal supports to each of the vertical leg assemblies using the $\frac{1}{4}$ "-20 x $\frac{3}{8}$ " carriage bolts, $\frac{1}{4}$ " flat washers and $\frac{1}{4}$ " nuts.
5. Place the stand on a level surface and tighten all the nuts using a 14mm wrench.



Figure 4. Stand assembled.



Lathe To Stand



1. Carefully place the lathe unit on the stand with the help of another person. Inspect the stand to make sure all the braces and legs are still secure.
2. Align the mounting hole in the top plates with those on each end of the bed casting.
3. Attach the lathe unit to the stand using the M8-1.25 x 35 cap screws, M8 flat washers and M8-1.25 nuts as shown in **Figure 5**. Securely tighten the cap screws.



Figure 5. Attaching lathe unit to stand.



Floor Mounting

We highly recommend mounting your Model G5979 to the floor. Doing so will eliminate any possibility of the lathe becoming unbalanced and tipping over. The lathe will also produce better results because there will be less vibration from the machine. To mount the lathe to the floor:

Wooden Floor:

Use 1/4" lag screws with flat washers. Be certain the floor is stable and level. Drill pilot holes into the floor and be careful not to tighten the lag bolts too much or the hole may become stripped out.

Concrete Floor:

Mounting the lathe to a concrete floor involves the use of stud anchors or some other similar fastener. Once the location is selected, drill the anchor holes into the concrete floor using a hammer drill and masonry bit. Be sure to follow the directions of the anchoring system you have chosen.

Once the lathe is secured to the floor, check to make sure it is still level and all the mounting bolts are secure. Shim if needed.



Headstock Lock

The headstock can be locked into position using the supplied locking handle. To install this handle:

1. Locate the handle, spring and special screw.
2. Slide the spring over the special screw. Push the screw through the locking handle and thread it into the locking clamp located on the side of the headstock.
3. The locking handle is designed so that it can be tightened down and then turned out of the way of the operator. To tighten down the handle, push in and turn clockwise. Releasing the handle will disengage the threaded shaft, allowing you to reposition the lever handle out of the way. To release the lock handle, push it in and turn counterclockwise.



Figure 7. Attaching the headstock lock handle.



Spur Center

The spur center is a M.T. #2. To install the spur center:

1. Make certain the spur center is clean and free of dirt or grease.

G5979 Wood Lathe

2. Press it into the headstock spindle.



Figure 8. Installing the spur center.

To remove the spur center:

1. Insert the push-out rod into the headstock spindle hole opposite the end of the spur center.
2. A firm push should release the spur center. You may have to tap on the end of the push rod with a rubber mallet. Be sure to hold the spur center before releasing it so it will not fall on the floor.



Figure 9. Removing the spur center.



Faceplate

The faceplate is used when turning plates, bowls and vases. The headstock spur must be removed before installing the faceplate. To install the faceplate:

1. Remove the headstock spur using the push rod.
2. Using two wrenches, thread on and tighten the faceplate/workpiece assembly onto the threaded spindle. Be sure to secure the faceplate tightly with two wrenches.



Figure 10. Attaching the faceplate.



Extension Bed

The extension bed mounts to the left hand side of the main lathe bed. To attach the extension bed:

1. Align the mounting holes of the extension bed and the main lathe bed.
2. Using the M10-1.5 x 25 cap screws and M10 lock washers, attach the extension bed.
3. Be sure to securely tighten the cap screws. The extension bed does not have to be perfectly level.

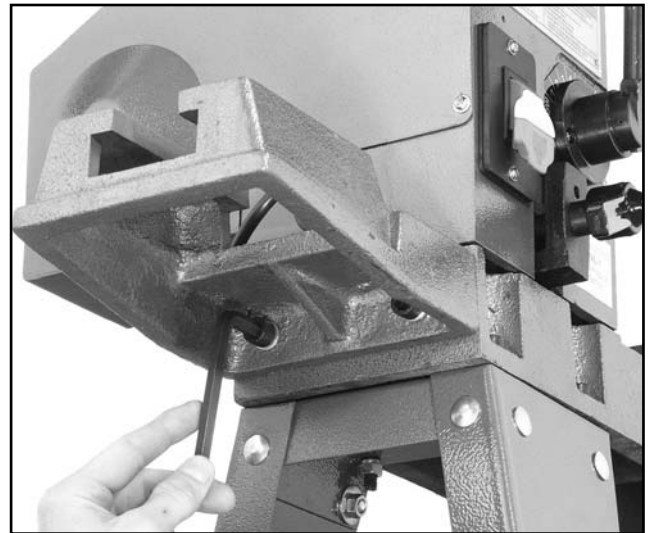
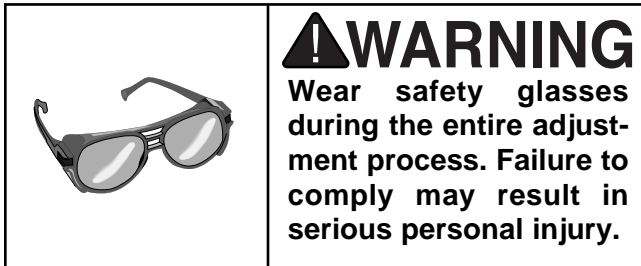
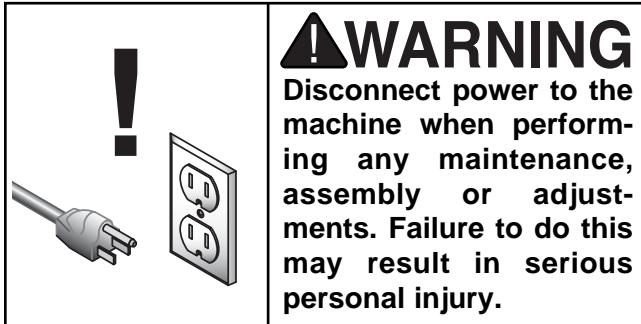

Figure 11. Attaching extension table.



SECTION 5: ADJUSTMENTS



Headstock

The headstock has 5 preset positions: 0° for general spindle turning; 60°, 90° and 120° when doing faceplate turnings where the workpiece extends below the level of the lathe/extension bed; and 180° when doing faceplate turning where the workpiece edge does not extend below the edge of the lathe/extension bed. To set the headstock to the desired degree:

1. Loosen the lock handle by turning counter-clockwise one full revolution.
2. Pull out on the headstock release knob and rotate the headstock clockwise to the desired setting. The headstock will be fixed into position when it clicks into one of the 5 preset positions.
3. Tighten the lock handle that was loosened in the first step. Do not attempt to lock the headstock into a position other than the 5 presets.

G5979 Wood Lathe



Figure 12. Adjusting headstock.



Tailstock

The tailstock can be moved along the length of the lathe bed. The tailstock barrel holds the live center, which can be adjusted up to 2½" from the tailstock housing. To adjust the tailstock and tailstock spindle:

1. Loosen the tailstock lock handle by lowering it and slide the tailstock to the desired position along the lathe bed. Retighten the tailstock lock handle by lifting it. The lock handle mechanism can be adjusted by tightening or loosening the large hex nut under the tailstock.
2. To adjust the tailstock barrel, loosen the spindle lock handle.
3. Rotate the tailstock spindle handwheel until the desired position is achieved. Retighten the tailstock spindle lock handle.
4. To remove the live center from the tailstock spindle, use the push-out rod inserted through the hollow center of the tailstock spindle.

-15-

Tool Rest

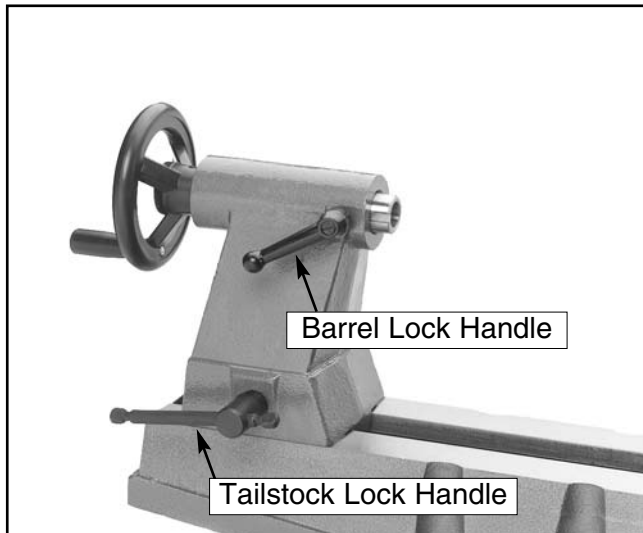

Figure 13. Tailstock assembly.

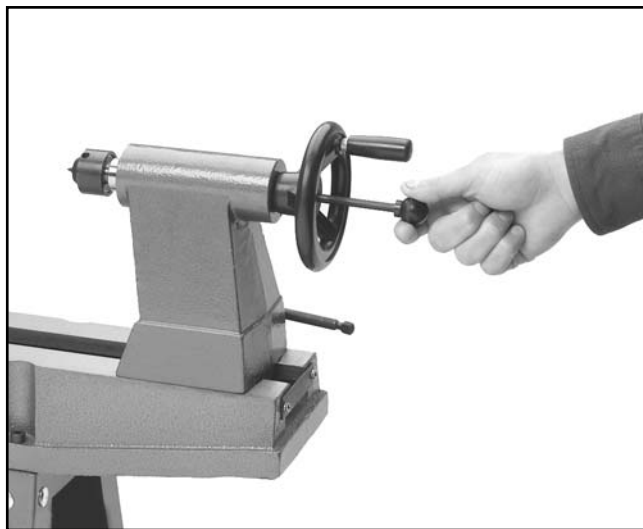

Figure 14. Removing live center.



The tool rest can be used with or without the extension arm. To adjust the tool rest:

1. To adjust the main base along the bed, loosen the lock lever and slide into the desired position. Retighten the lock lever.
2. When using the extension arm, make the necessary adjustments using the lock levers and adjusting the extension arm. Re-tighten the lock levers.
3. Make sure there is adequate clearance between the workpiece and the tool rest. Test by hand-turning the workpiece before turning the lathe on.

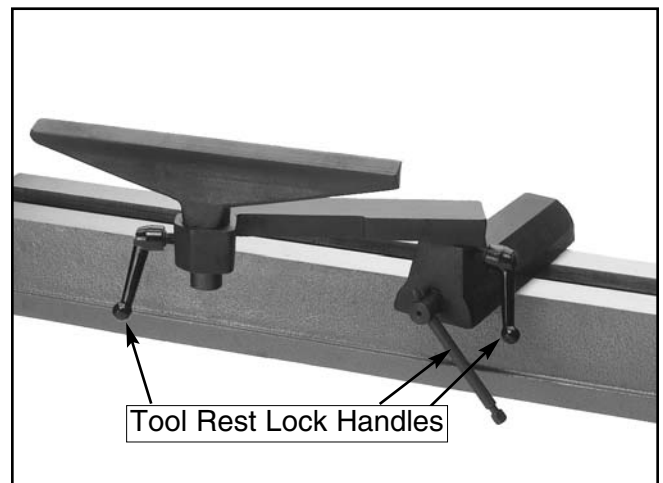

Figure 15. Tool rest assembly.



SECTION 5: OPERATIONS

Test Run



Once assembly is complete and adjustments are done to your satisfaction, you are ready to test run the machine.

Press the START button. Make sure that your finger is poised on the STOP button, just in case there is a problem. The lathe should run smoothly, with little or no vibration or rubbing noises. Strange or unnatural noises should be investigated and corrected before operating the machine further.

If you cannot easily locate the source of an unusual noise or vibration, contact our service department for help.



Speed Selector

The variable speed selector allows the adjustment of the spindle R.P.M. The lathe should only be turned ON when the speed is set at the lowest R.P.M. The lathe must be ON to adjust the speed; therefore, be sure to set the speed to the lowest R.P.M. before turning OFF the machine.

G5979 Wood Lathe

The speed control lever can be turned to one of ten fixed speeds. To set the speed:

1. Turn the lathe ON. Make sure that your finger is poised on the STOP button, just in case there is a problem. The lathe should run smoothly, with little or no vibration or rubbing noises. Strange or unnatural noises should be investigated and corrected before operating the machine further. If you cannot easily locate the source of an unusual noise or vibration, contact our service department for help.
2. Pull back on the lever handle and rotate to the next higher speed as shown in **Figure 16**.
3. Turn the lever handle clockwise along the index plate to increase the speed and counterclockwise to decrease the speed.
4. Remember to turn the lever handle to the slowest R.P.M. before turning off the machine.

⚠ CAUTION

Remember to choose the correct speed for your particular turning project. As a general rule, the larger the workpiece diameter, the slower the speed. Always start and stop at the slowest speed.



Figure 16. Adjusting spindle speed.



Spindle Turning

To mount a workpiece between centers:

1. Locate the center point on both ends of the workpiece by carefully drawing diagonal lines from corner to corner. The point of intersection is the center of the work. Find the center of a round workpiece by using a center finder instrument.
2. When turning stock with a diameter greater than 2", remove the corner length edges shown in **Figure 17**.

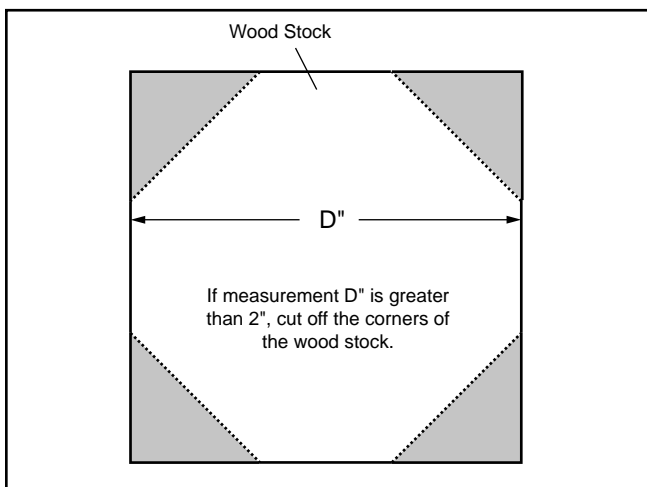

Figure 17. Cross-section of turning stock.

3. Line up the center of the spur center with the center mark on the end of the workpiece. While supporting the workpiece, slide the tailstock close to the end of the workpiece and lock it into place.
4. Line up the live center with the center mark on the other end of the workpiece. Turn the handwheel to press the point of the live center into the workpiece.
5. Lock the tailstock in place.

WARNING

Do not press too firmly or the bearings will bind and overheat. Likewise, do not adjust too loosely or the workpiece will spin off the lathe. Use good judgement. Serious personal injury could result if care is not taken.



Faceplate Turning

Faceplate turning projects fall into two categories: those that extend below the level of the lathe/extension bed and those that do not. If your project will rotate below the level of the lathe/extension bed, you will need to rotate the headstock to the 60° or 90° positions (discussed further in **Adjustments** section). But if your project does not extend below the lathe/extension bed, it is safest to rotate the headstock 180° so the project will rotate over the extension bed. This allows the operator to stand directly in front of the project and allows use of the tool rest without the extension arm, thus, eliminating undue flexing of the tool rest.



Figure 19. Faceplate turning large projects.



Figure 20. Faceplate turning small projects.

1. Locate the center point of the workpiece by carefully drawing diagonal lines from corner to corner. The point of intersection is the center of the work. Find the center of round workpiece by using a center finder instrument.

2. Using 4 wood screws, attach the workpiece as close to the center of the faceplate as possible. Make sure that the wood screws will not interfere with the lathe chisels or intended cuts.
3. Adjust the headstock to the desired position for the turning operation that you will be performing.
4. Attach the faceplate/workpiece assembly to the headstock spindle using two wrenches.



Tool Rest

Adjust the tool rest as close to the workpiece as possible without actually coming into contact with the workpiece. Test by hand-turning the workpiece before turning the lathe on. Ensure that the lathe chisel is fully supported by the tool rest. Support the lathe chisel on the tool rest with one hand, while the other hand controls the chisel. See **Figure 21**.



Figure 21. Proper hand positioning.

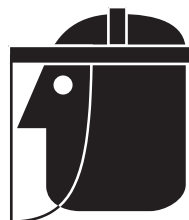

WARNING
Wear a face shield during the test run and operation of this wood working lathe. Failure to do so could result in serious injury.



SECTION 7: MAINTENANCE

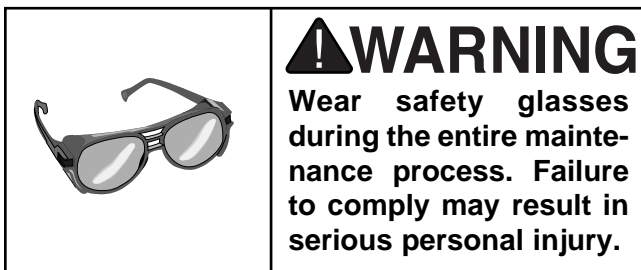
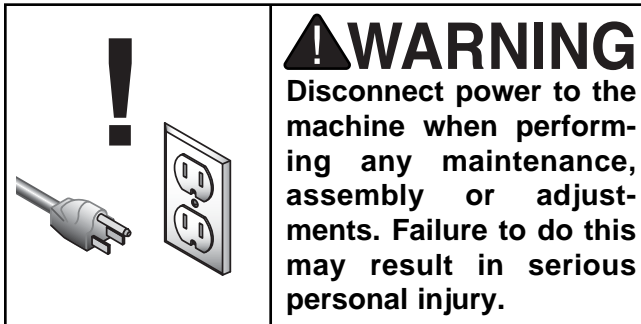

General

Regular periodic maintenance on your Model G5979 will ensure its optimum performance. Make a habit of inspecting your machine each time you use it. Check for the following conditions and repair or replace when necessary:

1. Loose mounting bolts.
2. Worn switch.
3. Worn or damaged cords and plugs.
4. Damaged V-belt.
5. Any other condition that could hamper the safe operation of this machine.



Rust

The nonpainted surfaces on the Model G5979 should be protected against rust and pitting. Wiping the machine clean after every use ensures that wood dust will not trap moisture against bare metal surfaces.



Lubrication

All bearings are shielded and permanently lubricated. Simply leave them alone until they need to be replaced. Do not lubricate them.

The end of the motor shaft has a lube fitting that requires periodic lubrication. It is very important not to over lube this fitting; otherwise, dirt and debris will collect on the motor shaft, causing premature failure of the pulley mechanism. We recommend using a few shots of light spindle oil.



V-Belt

Inspect regularly for tension and wear. Check pulleys to ensure that they are properly aligned. See pulley/V-belt sections for proper tension and pulley alignment procedures.



Dust/Chip Removal

Saw dust and wood chips allowed to sit on cast iron surfaces can trap moisture and cause rust. Regularly wipe or blow sawdust and chip buildup off of the lathe unit. This will help reduce the chance of rust.



SECTION 8: CLOSURE

The following pages contain general machine data, parts diagrams/lists, a troubleshooting guide and Warranty/Return information for your Model G5979.

If you need parts or help in assembling your machine, or if you need operational information, we encourage you to call our Service Department. Our trained service technicians will be glad to help you.

If you have comments dealing specifically with this manual, please write to our Bellingham, Washington location using the address in **Section 3: Introduction**.

We have included some important safety measures that are essential to this machine's operation. While most safety measures are generally universal, Grizzly reminds you that each workshop is different and safety rules should be considered as they apply to your specific situation.

WARNING

Operating this equipment creates the potential for flying debris to cause eye injury. Always wear safety glasses or goggles when operating equipment. Everyday glasses or reading glasses only have impact resistant lenses, they are not safety glasses. Be certain the safety glasses you wear meet the appropriate standards of the American National Standards Institute (ANSI).

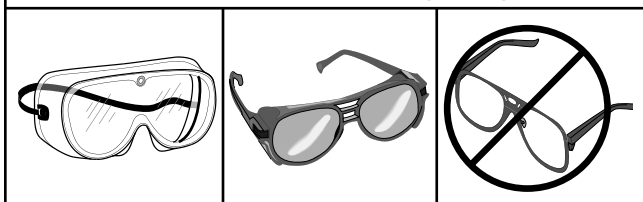

We recommend you keep a copy of our current catalog for complete information regarding Grizzly's warranty and return policy. If you need additional technical information relating to this machine, or if you need general assistance or replacement parts, please contact the Service Department listed in **Section 3: Introduction**.

Additional information sources are necessary to realize the full potential of this machine. Trade journals, woodworking magazines, and your local library are good places to start.

WARNING

The Model G5979 was specifically designed for wood turning operations. **DO NOT MODIFY AND/OR USE THIS MACHINE FOR ANY OTHER PURPOSE.** Modifications or improper use of this tool will void the warranty. If you are confused about any aspect of this machine, **DO NOT** use it until all your questions have been answered or serious personal injury may occur.

WARNING

Like all power tools, there is danger associated with the Model G5979. Accidents are frequently caused by lack of familiarity or failure to pay attention. Use this tool with respect and caution to lessen the possibility of operator injury. If normal safety precautions are overlooked or ignored, serious personal injury may occur.





MACHINE DATA SHEET

Customer Service #: (570) 546-9663 • To Order Call: (800) 523-4777 • Fax #: (800) 438-5901

GRIZZLY MODEL G5979 SWIVEL HEAD WOOD LATHE

Design TypeBench Model

Overall Dimensions:

Height44"
Length60"
Shipping Weight190 lbs.
Box Size54½" L x 13" W x 14" H
Footprint43½" x 18½"

Construction:

BedCast Iron Flat Ways
Headstock.....Cast Iron

Specifications:

Inboard Spindle Size, Type1" x 8 T.P.I.
TailstockMT #2
SpindleMT #2
Range Of Speeds10 @ 580 - 2850 R.P.M.
Swing12"
Distance Between Centers35½"
Swing Over Tool Rest9"
Swivel HeadStops @ 90° and 180°

Motor:

TypeTEFC Capacitor Start Induction
Horsepower½ H.P.
Phase / CycleSingle / 60 Hz
Voltage110V
Amperage4A
R.P.M.1720
BearingsSealed and Permanently Lubricated

Accessories:

.....Tool Rest
.....Live Rolling Center
.....Spur Center
.....Face Plate
.....Extension Bed for Out-Board Turning
.....Tool Rest Extension
.....Paddle Switch

Specifications, while deemed accurate, are not guaranteed.

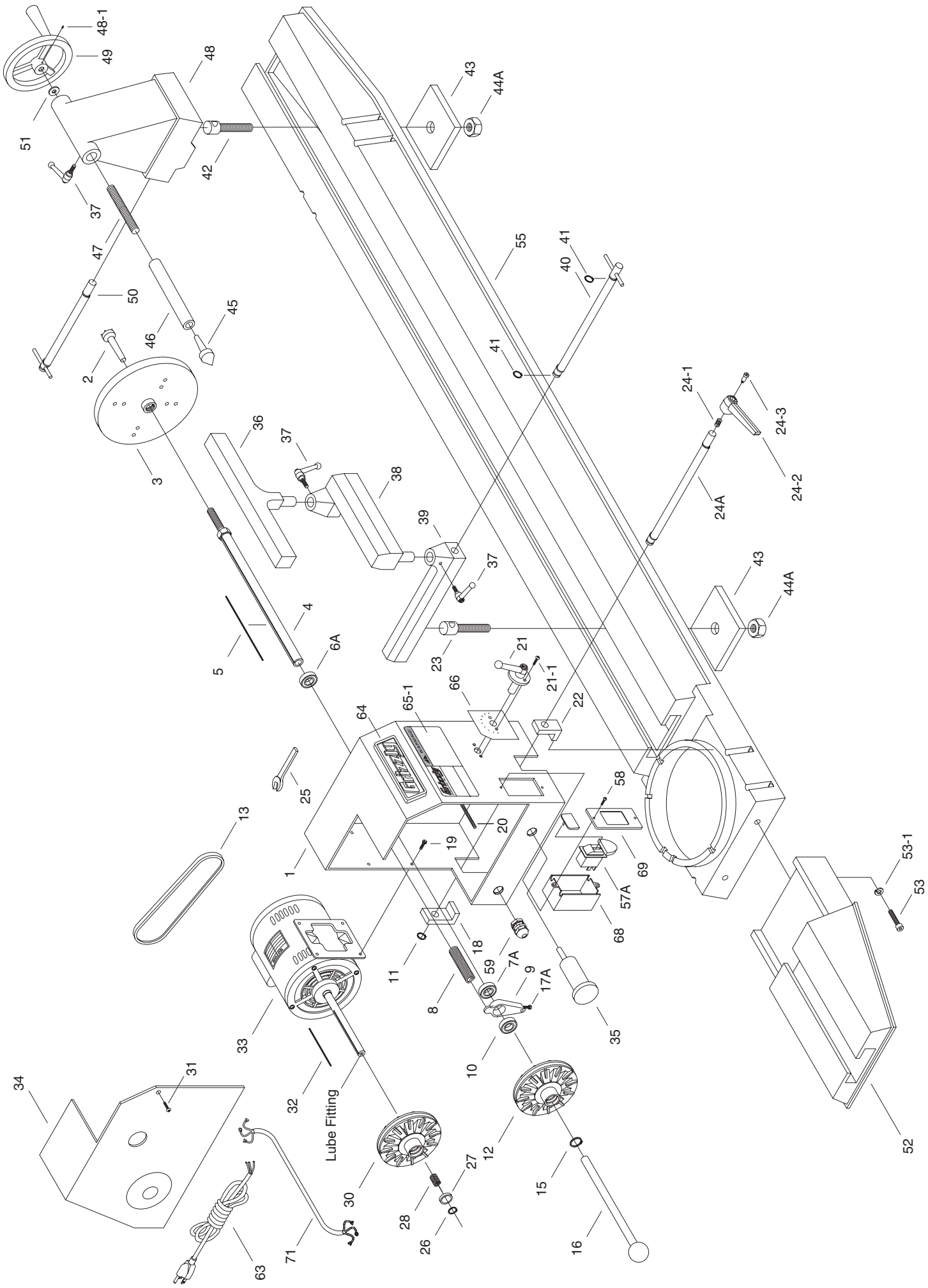

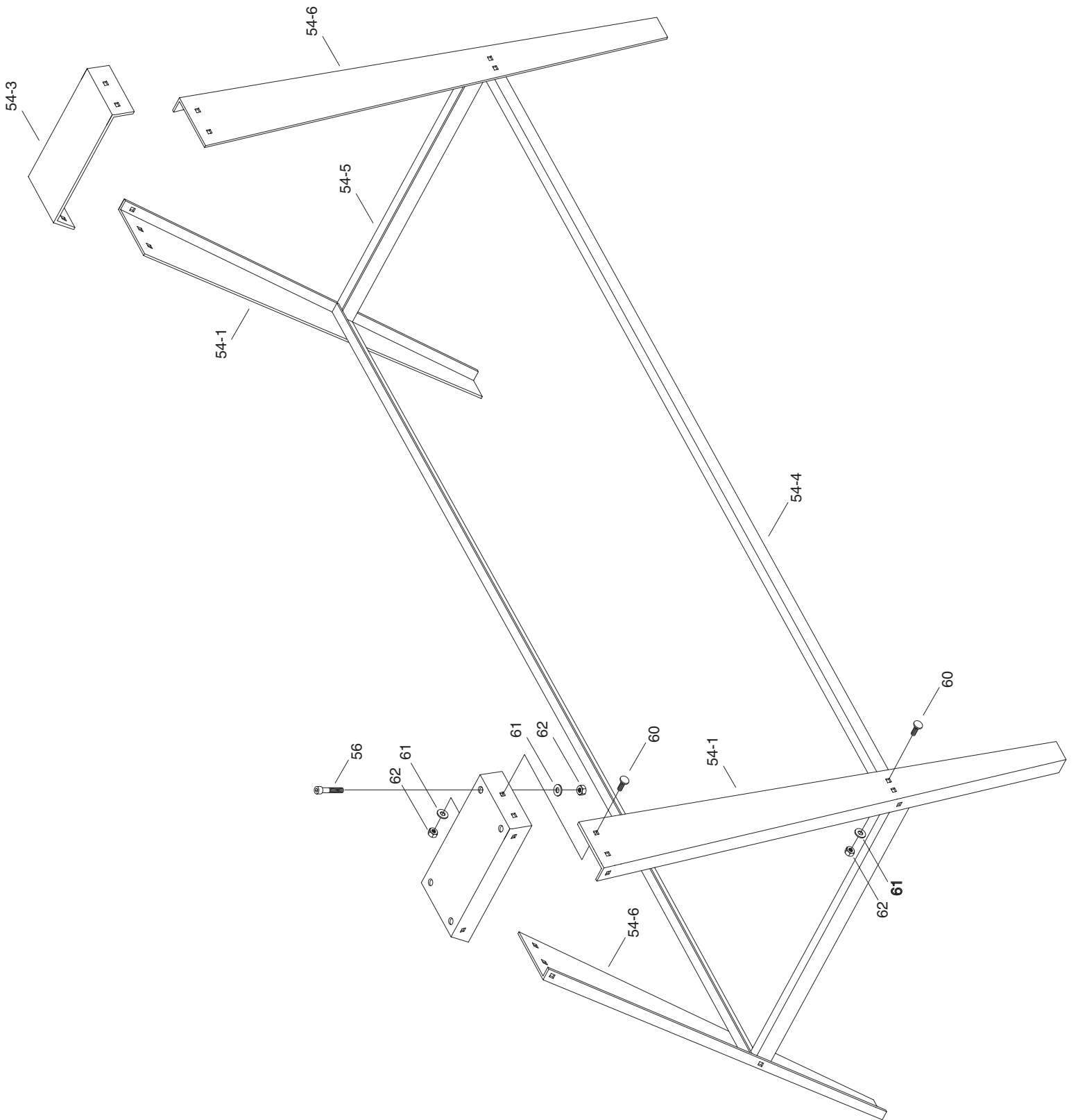

Ref#	Part#	Description
01	P5979001	HEADSTOCK
02	P5979002	DRIVE CENTER
03	P5979003	DISC
04	P5979004	SPINDLE
05	PK18M	KEY 4 X 4 X 82
06A	P5979006A	BALL BEARING 80205Z
07A	P5979007A	BALL BEARING 80205Z
008	P5979008	SPRING
09	P5979009	BRACKET—SHIFTING LEVER
10	P6006	BALL BEARING 6006ZZ
11	P5979011	C-RING S-25
12	P5979012	SPINDLE PULLEY SET R & L
13	PVM23	V-BELT M-23 3L230
15	P5979015	C-RING S-24
16	P5979016	PIN-INJECTION
17A	PLN09	LOCK NUT M12-1.75
18	P5979018	CLAMP LEFT
19	PB07M	HEX BOLT M8-1.25 X 25
20	P5979020	RACK
21	P5979021	GEAR ASSEMBLY
21-1	PS09M	PHLP HD SCR M5-.8 X 10
22	P5979022	CLAMP RIGHT
23	P5979023	SPECIAL SCREW
24A	P5979024A	SHAFT
24-1	P5979024-1	SPRING
24-2	P5979024-2	LOCK HANDLE
24-3	P5979024-3	SPECIAL CAP SCREW
25	P5979025	WRENCH
26	P5979026	C-RING S-16
27	P5979027	SLEEVE
28	P5979028	SPRING
30	P5979030	MOTOR PULLEY SET, L & R
31	PS09M	PHLP HD SCR M5-.8 X 10
32	PK18M	KEY 4 x 4 x 82
33	P5979033	½ H.P. MOTOR
34	P5979034	MOTOR COVER
35	P5979035	ANGULAR SETTING ASSEMBLY
36	P5979036	TOOL REST
37	P5979037	HANDLE ASSEMBLY
38	P5979038	EXTENSION TOOL REST

Ref#	Part#	Description
39	P5979039	TOOL REST BODY
40	P5979040	ECCENTRIC ROD
41	PR08M	EXT RETAINING RING 19MM
42	P5979042	SPECIAL SCREW
43	P5979043	CLAMP
44A	P5979044A	HEX NUT M18-2.5
45	P5979045	CENTER
46	P5979046	TAIL SPINDLE
47	P5979047	TAILSTOCK SCREW
48	P5979048	TAILSTOCK
48-1	PPSS25M	SET SCREW M6-1 X 20
49	P5979049	HANDWHEEL
50	P5979050	LOCK HANDLE-TAILSTOCK
51	P5979051	SPECIAL BOLT
52	P5979052	EXTENSION BED
53	PSB64M	CAP SCREW M10-1.5 X 25
53-1	PLW06M	LOCK WASHER 10MM
54-1	P5979054-1	STAND LEG, LEFT
54-3	P5979054-3	STAND UPPER COVER
54-4	P5979054-4	STAND LONG-CROSS SUPPORT
54-5	P5979054-5	STAND SHORT-CROSS SUPPORT
54-6	P5979054-6	STAND LEG, RIGHT
55	P5979055	BED
56	PSB11M	CAP SCREW M8-1.25 x 16
57A	PSW08	SWITCH 110V WITH KEY
58	PS21M	PHLP HD SCR M4-.7 X 15
59	P5979059	PLASTIC JAM NUT M20 X 1.5
60	PCB02M	CARRIAGE BOLT M8-1.25 x 10
61	PW01M	FLAT WASHER 8MM
62	PN03M	HEX NUT M8-1.25
63	PWRCD110L	POWER CORD 110V, LONG W/PLUG
64	P5979064	LOGO LABEL
65-1	P5979065-1	GRIZZLY ID/WARNING LABEL
66	P5979066	SPEED LABEL
68	P5979068	SWITCH BOX
69	P5979069	SWITCH FIXING PLATE
71	P5979071	MOTOR POWER WIRE

WARRANTY AND RETURNS

Grizzly Industrial, Inc. warrants every product it sells for a period of **1 year** to the original purchaser from the date of purchase. This warranty does not apply to defects due directly or indirectly to misuse, abuse, negligence, accidents, repairs or alterations or lack of maintenance. This is Grizzly's sole written warranty and any and all warranties that may be implied by law, including any merchantability or fitness, for any particular purpose, are hereby limited to the duration of this written warranty. We do not warrant or represent that the merchandise complies with the provisions of any law or acts unless the manufacturer so warrants. In no event shall Grizzly's liability under this warranty exceed the purchase price paid for the product and any legal actions brought against Grizzly shall be tried in the State of Washington, County of Whatcom.

We shall in no event be liable for death, injuries to persons or property or for incidental, contingent, special, or consequential damages arising from the use of our products.

To take advantage of this warranty, contact us by mail or phone and give us all the details. We will then issue you a "Return Number," which must be clearly posted on the outside as well as the inside of the carton. We will not accept any item back without this number. Proof of purchase must accompany the merchandise.

The manufacturers reserve the right to change specifications at any time because they constantly strive to achieve better quality equipment. We make every effort to ensure that our products meet high quality and durability standards and we hope you never need to use this warranty.

Please feel free to write or call us if you have any questions about the machine or the manual.

Thank you again for your business and continued support. We hope to serve you again soon.

WARRANTY CARD

Name _____
Street _____
City _____ State _____ Zip _____
Phone Number _____ E-Mail _____ FAX _____
MODEL # G5979 Wood Lathe Order # _____

The following information is given on a voluntary basis. It will be used for marketing purposes to help us develop better products and services. Of course, all information is strictly confidential.

- How did you learn about us?
 Advertisement Friend
 Catalog Card Deck
 World Wide Web
 Other _____
- Which of the following magazines do you subscribe to.
 American Woodworker Practical Homeowner
 Cabinetmaker Shop Notes
 Family Handyman Today's Homeowner
 Fine Homebuilding WOOD
 Fine Woodworking Wooden Boat
 Home Handyman Woodshop News
 Journal of Light Construction Woodsmith
 Old House Journal Woodwork
 Popular Mechanics Woodworker
 Popular Science Woodworker's Journal
 Popular Woodworking Workbench
 Other _____
- Which of the following woodworking/remodeling shows do you watch?
 Backyard America The New Yankee Workshop
 Home Time This Old House
 The American Woodworker Woodwright's Shop
 Other _____
- What is your annual household income?
 \$20,000-\$29,999 \$60,000-\$69,999
 \$30,000-\$39,999 \$70,000-\$79,999
 \$40,000-\$49,999 \$80,000-\$89,999
 \$50,000-\$59,999 \$90,000 +
- What is your age group?
 20-29 50-59
 30-39 60-69
 40-49 70 +
- How long have you been a woodworker?
 0 - 2 Years 8 - 20 Years
 2 - 8 Years 20+ Years
- How would you rank your woodworking skills?
 Simple Advanced
 Intermediate Master Craftsman
- What stationary woodworking tools do you own? Check all that apply.
 Air Compressor Panel Saw
 Band Saw Planer
 Drill Press Power Feeder
 Drum Sander Radial Arm Saw
 Dust Collector Shaper
 Horizontal Boring Machine Spindle Sander
 Jointer Table Saw
 Lathe Vacuum Veneer Press
 Mortiser Wide Belt Sander
 Other _____
- How many of your woodworking machines are Grizzly? _____
- Which benchtop tools do you own? Check all that apply.
 1" x 42" Belt Sander 6" - 8" Grinder
 5" - 8" Drill Press Mini Lathe
 8" Table Saw 10" - 12" Thickness Planer
 8" - 10" Bandsaw Scroll Saw
 Disc/Belt Sander Spindle/Belt Sander
 Mini Jointer
 Other _____
- How many of the machines checked above are Grizzly? _____
- Which portable/hand held power tools do you own? Check all that apply.
 Belt Sander Orbital Sander
 Biscuit Joiner Palm Sander
 Circular Saw Portable Planer
 Detail Sander Saber Saw
 Drill/Driver Reciprocating Saw
 Miter Saw Router
 Other _____
- What machines/supplies would you like Grizzly Industrial to carry?

- What new accessories would you like Grizzly Industrial to carry?

- What other companies do you purchase your tools and supplies from?

- Do you think your purchase represents good value?
 Yes No
- Would you recommend Grizzly Industrial to a friend?
 Yes No
- Would you allow us to use your name as a reference for Grizzly customers in your area? **Note: We never use names more than three times.**
 Yes No
- Comments: _____

FOLD ALONG DOTTED LINE

||| ||| |||

Place
Stamp
Here



GRIZZLY INDUSTRIAL, INC.
P.O. BOX 2069
BELLINGHAM, WA 98227-2069



FOLD ALONG DOTTED LINE

Send a Grizzly Catalog to a friend:

Name _____

Street _____

City _____ State _____ Zip _____

TAPE ALONG EDGES--PLEASE DO NOT STAPLE

Free Manuals Download Website

<http://myh66.com>

<http://usermanuals.us>

<http://www.somanuals.com>

<http://www.4manuals.cc>

<http://www.manual-lib.com>

<http://www.404manual.com>

<http://www.luxmanual.com>

<http://aubethermostatmanual.com>

Golf course search by state

<http://golfingnear.com>

Email search by domain

<http://emailbydomain.com>

Auto manuals search

<http://auto.somanuals.com>

TV manuals search

<http://tv.somanuals.com>