

# **Grizzly** **Industrial, Inc.**®

## **MODEL T10726** **12" VISE-MOUNT** **PAN & BOX BRAKE** **OWNER'S MANUAL** *(For models manufactured since 12/12)*



COPYRIGHT © JANUARY, 2013 BY GRIZZLY INDUSTRIAL, INC.  
**WARNING: NO PORTION OF THIS MANUAL MAY BE REPRODUCED IN ANY SHAPE  
OR FORM WITHOUT THE WRITTEN APPROVAL OF GRIZZLY INDUSTRIAL, INC.**  
#TS15553 PRINTED IN CHINA

 **WARNING!**

**This manual provides critical safety instructions on the proper setup, operation, maintenance, and service of this machine/tool. Save this document, refer to it often, and use it to instruct other operators.**

**Failure to read, understand and follow the instructions in this manual may result in fire or serious personal injury—including amputation, electrocution, or death.**

**The owner of this machine/tool is solely responsible for its safe use. This responsibility includes but is not limited to proper installation in a safe environment, personnel training and usage authorization, proper inspection and maintenance, manual availability and comprehension, application of safety devices, cutting/sanding/grinding tool integrity, and the usage of personal protective equipment.**

**The manufacturer will not be held liable for injury or property damage from negligence, improper training, machine modifications or misuse.**

 **WARNING!**

**Some dust created by power sanding, sawing, grinding, drilling, and other construction activities contains chemicals known to the State of California to cause cancer, birth defects or other reproductive harm. Some examples of these chemicals are:**

- **Lead from lead-based paints.**
- **Crystalline silica from bricks, cement and other masonry products.**
- **Arsenic and chromium from chemically-treated lumber.**

**Your risk from these exposures varies, depending on how often you do this type of work. To reduce your exposure to these chemicals: Work in a well ventilated area, and work with approved safety equipment, such as those dust masks that are specially designed to filter out microscopic particles.**

# Table of Contents

<b>INTRODUCTION</b> .....	<b>2</b>
Machine Description.....	2
Contact Info.....	2
Manual Accuracy.....	2
Identification.....	3
Specifications.....	3
<b>SECTION 1: SAFETY</b> .....	<b>4</b>
Safety Instructions for Machinery.....	4
Additional Safety for Brakes.....	6
<b>SECTION 2: SETUP</b> .....	<b>7</b>
Unpacking.....	7
Needed for Setup.....	7
Inventory.....	7
Cleanup.....	8
Site Considerations.....	8
Workbench Load.....	8
Placement Location.....	8
Workbench Mounting.....	9
Assembly.....	9
<b>SECTION 3: OPERATIONS</b> .....	<b>10</b>
Basic Bending.....	10
Removing/Spacing Fingers.....	11
<b>SECTION 4: ACCESSORIES</b> .....	<b>12</b>
<b>SECTION 5: MAINTENANCE</b> .....	<b>14</b>
<b>SECTION 6: SERVICE</b> .....	<b>15</b>
Troubleshooting.....	15
Finger Alignment.....	16
<b>SECTION 7: PARTS</b> .....	<b>17</b>
Main.....	17
Labels.....	18
<b>WARRANTY &amp; RETURNS</b> .....	<b>21</b>

# INTRODUCTION

## Machine Description

This 12" Vise-Mounted Pan & Box Brake is designed for small bending projects (such as boxes, pans, and trays) in sheet metal that is 22 gauge or thinner.

When secured in a sturdy bench-mounted vise, four fingers of different lengths can be arranged in a variety of combinations to make 90° bends of varying widths up to 12" wide. The adjustable fingers also permit the sides of a box to be bent without interfering with previously bent sides.

## Contact Info

We stand behind our machines. If you have any questions or need help, use the information below to contact us. Before contacting, please get the serial number and manufacture date of your machine. This will help us help you faster.

Grizzly Technical Support  
1203 Lycoming Mall Circle  
Muncy, PA 17756  
Phone: (570) 546-9663  
Email: techsupport@grizzly.com

We want your feedback on this manual. What did you like about it? Where could it be improved? Please take a few minutes to give us feedback.

Grizzly Documentation Manager  
P.O. Box 2069  
Bellingham, WA 98227-2069  
Email: manuals@grizzly.com

## Manual Accuracy

We are proud to provide a high-quality owner's manual with your new machine!

We made every effort to be exact with the instructions, specifications, drawings, and photographs contained inside. Sometimes we make mistakes, but our policy of continuous improvement also means that **sometimes the machine you receive will be slightly different than what is shown in the manual.**

If you find this to be the case, and the difference between the manual and machine leaves you confused about a procedure, check our website for an updated version. We post current manuals and manual updates for free on our website at [www.grizzly.com](http://www.grizzly.com).

Alternatively, you can call our Technical Support for help. Before calling, please write down the **Manufacture Date** and **Serial Number** stamped into the machine ID label (see below). This information helps us determine if updated documentation is available for your machine.

		<b>MODEL GXXXX</b>	
		<b>MACHINE NAME</b>	
<b>SPECIFICATIONS</b>		<b>⚠ WARNING!</b>	
Motor:		To reduce risk of serious injury when using this machine:	
Specification:		1. Read manual before operation.	
Specification:		2. Wear safety glasses and respirator.	
Specification:		3. Make sure safety devices are properly adjusted/setup and	
Specification:		4. power is connected to grounded circuit before starting.	
Weight:		5. Make sure the motor has stopped and disconnect	
		6. power before adjustments, maintenance, or service.	
		7. DO NOT expose to rain or dampness.	
		8. DO NOT modify this machine in any way.	
		9. Do not operate if you are tired, drowsy, or have	
		10. Use of drugs or alcohol.	
		11. Maintain machine carefully to prevent accidents.	

Manufactured for Grizzly in Taiwan

Manufacture Date: \_\_\_\_\_

Serial Number: \_\_\_\_\_



# Identification

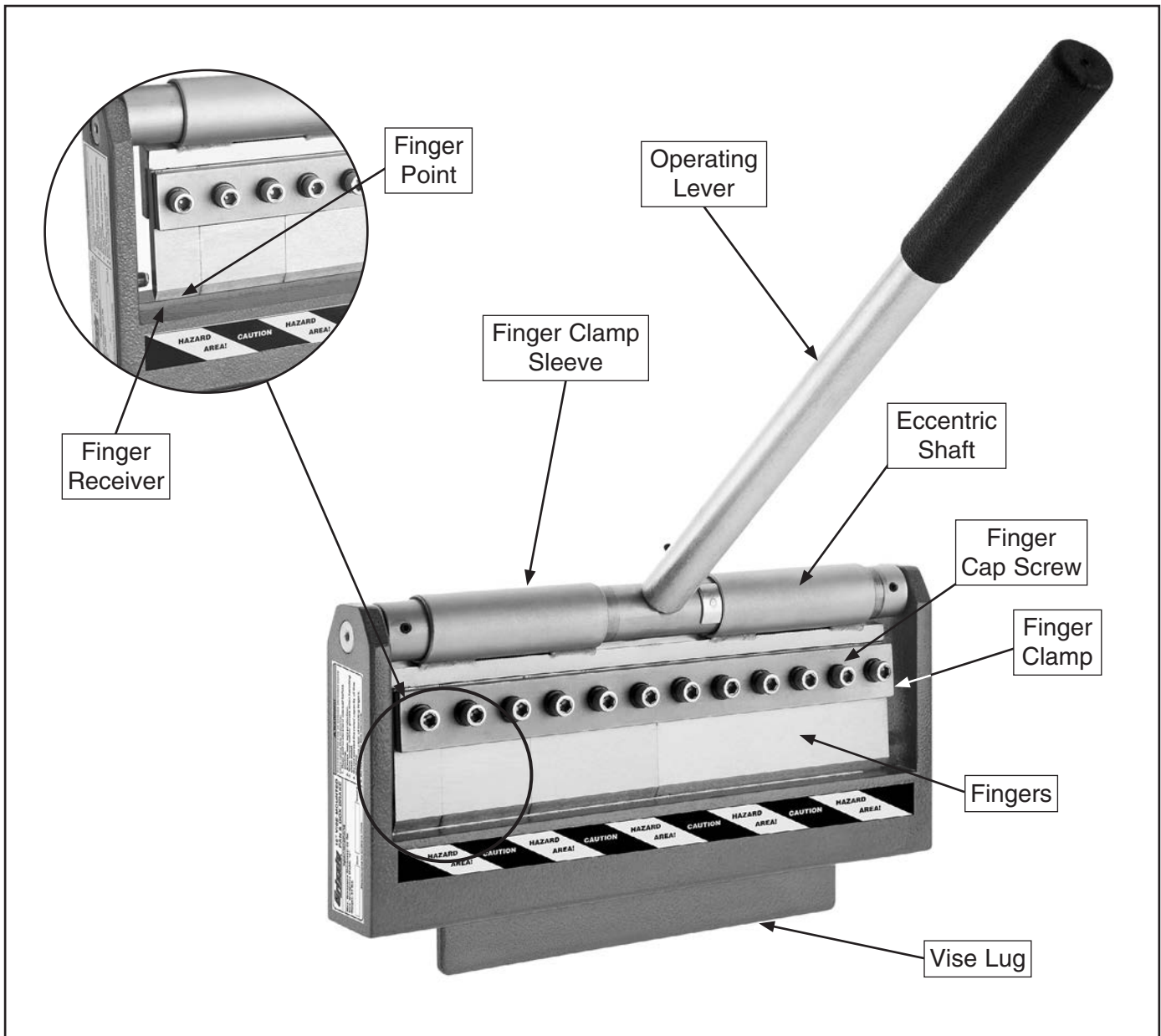

# Specifications

Maximum Bending Width ..... 12"  
 Maximum Bending Capacity ... 22 Ga. Mild Steel  
 Bending Angle Range ..... 0°–90°

Number of Fingers..... 4  
 Finger Sizes..... 1", 2", 3", and 6"  
 Weight .....22 lbs.



# SECTION 1: SAFETY

## For Your Own Safety, Read Instruction Manual Before Operating This Machine

The purpose of safety symbols is to attract your attention to possible hazardous conditions. This manual uses a series of symbols and signal words intended to convey the level of importance of the safety messages. The progression of symbols is described below. Remember that safety messages by themselves do not eliminate danger and are not a substitute for proper accident prevention measures. Always use common sense and good judgment.

 **DANGER** Indicates an imminently hazardous situation which, if not avoided, **WILL** result in death or serious injury.

 **WARNING** Indicates a potentially hazardous situation which, if not avoided, **COULD** result in death or serious injury.

 **CAUTION** Indicates a potentially hazardous situation which, if not avoided, **MAY** result in minor or moderate injury. It may also be used to alert against unsafe practices.

**NOTICE** This symbol is used to alert the user to useful information about proper operation of the machine.

## Safety Instructions for Machinery

### **WARNING**

**OWNER'S MANUAL.** Read and understand this owner's manual **BEFORE** using machine.

**TRAINED OPERATORS ONLY.** Untrained operators have a higher risk of being hurt or killed. Only allow trained/supervised people to use this machine. When machine is not being used, disconnect power, remove switch keys, or lock-out machine to prevent unauthorized use—especially around children. Make workshop kid proof!

**DANGEROUS ENVIRONMENTS.** Do not use machinery in areas that are wet, cluttered, or have poor lighting. Operating machinery in these areas greatly increases the risk of accidents and injury.

**MENTAL ALERTNESS REQUIRED.** Full mental alertness is required for safe operation of machinery. Never operate under the influence of drugs or alcohol, when tired, or when distracted.

**ELECTRICAL EQUIPMENT INJURY RISKS.** You can be shocked, burned, or killed by touching live electrical components or improperly grounded machinery. To reduce this risk, only allow qualified service personnel to do electrical installation or repair work, and always disconnect power before accessing or exposing electrical equipment.

**DISCONNECT POWER FIRST.** Always disconnect machine from power supply **BEFORE** making adjustments, changing tooling, or servicing machine. This prevents an injury risk from unintended startup or contact with live electrical components.

**EYE PROTECTION.** Always wear ANSI-approved safety glasses or a face shield when operating or observing machinery to reduce the risk of eye injury or blindness from flying particles. Everyday eyeglasses are not approved safety glasses.



# WARNING

**WEARING PROPER APPAREL.** Do not wear clothing, apparel or jewelry that can become entangled in moving parts. Always tie back or cover long hair. Wear non-slip footwear to avoid accidental slips, which could cause loss of workpiece control.

**HAZARDOUS DUST.** Dust created while using machinery may cause cancer, birth defects, or long-term respiratory damage. Be aware of dust hazards associated with each workpiece material, and always wear a NIOSH-approved respirator to reduce your risk.

**HEARING PROTECTION.** Always wear hearing protection when operating or observing loud machinery. Extended exposure to this noise without hearing protection can cause permanent hearing loss.

**REMOVE ADJUSTING TOOLS.** Tools left on machinery can become dangerous projectiles upon startup. Never leave chuck keys, wrenches, or any other tools on machine. Always verify removal before starting!

**INTENDED USAGE.** Only use machine for its intended purpose and never make modifications not approved by Grizzly. Modifying machine or using it differently than intended may result in malfunction or mechanical failure that can lead to serious personal injury or death!

**AWKWARD POSITIONS.** Keep proper footing and balance at all times when operating machine. Do not overreach! Avoid awkward hand positions that make workpiece control difficult or increase the risk of accidental injury.

**CHILDREN & BYSTANDERS.** Keep children and bystanders at a safe distance from the work area. Stop using machine if they become a distraction.

**GUARDS & COVERS.** Guards and covers reduce accidental contact with moving parts or flying debris. Make sure they are properly installed, undamaged, and working correctly.

**FORCING MACHINERY.** Do not force machine. It will do the job safer and better at the rate for which it was designed.

**NEVER STAND ON MACHINE.** Serious injury may occur if machine is tipped or if the cutting tool is unintentionally contacted.

**STABLE MACHINE.** Unexpected movement during operation greatly increases risk of injury or loss of control. Before starting, verify machine is stable and mobile base (if used) is locked.

**USE RECOMMENDED ACCESSORIES.** Consult this owner's manual or the manufacturer for recommended accessories. Using improper accessories will increase the risk of serious injury.

**UNATTENDED OPERATION.** To reduce the risk of accidental injury, turn machine **OFF** and ensure all moving parts completely stop before walking away. Never leave machine running while unattended.

**MAINTAIN WITH CARE.** Follow all maintenance instructions and lubrication schedules to keep machine in good working condition. A machine that is improperly maintained could malfunction, leading to serious personal injury or death.

**CHECK DAMAGED PARTS.** Regularly inspect machine for any condition that may affect safe operation. Immediately repair or replace damaged or mis-adjusted parts before operating machine.

**MAINTAIN POWER CORDS.** When disconnecting cord-connected machines from power, grab and pull the plug—NOT the cord. Pulling the cord may damage the wires inside. Do not handle cord/plug with wet hands. Avoid cord damage by keeping it away from heated surfaces, high traffic areas, harsh chemicals, and wet/damp locations.

**EXPERIENCING DIFFICULTIES.** If at any time you experience difficulties performing the intended operation, stop using the machine! Contact our Technical Support at (570) 546-9663.



# **WARNING**

## **Additional Safety for Brakes**

**CRUSHING & AMPUTATION INJURIES.** The brake can quickly crush or amputate fingers or hands. Never place fingers or hands underneath fingers.

**SECURING Brake.** Before using, secure brake to a sturdy vise that is securely fastened to a workbench that can support the weight and dynamic forces involved in bending sheet metal. Otherwise, the brake may unexpectedly move or fall, causing serious injury or property damage.

**METAL EDGES.** Sharp edges on sheet metal can result in severe cuts. Always wear leather gloves and chamfer/de-burr sharp sheet metal edges before handling.

**TOOLS IN POOR CONDITION.** Using this tool with loose hardware or damaged components could result in sudden, uncontrolled movements during use. Inspect the brake for cracked components, damaged linkage, levers, or loose fasteners. Correct any problems before use.

**PINCHING.** To prevent pinching injuries, lower the fingers when not in use.

**GLOVES AND GLASSES.** Always wear leather gloves and approved safety glasses when using this brake.

**HEATING METAL.** Heating the workpiece with a torch while it is in the brake will weaken the metal of the fingers and frame. Do not use a torch or other similar heating tool near the brake.

**BACK INJURIES.** The operating lever motion required to operate this brake is potentially harmful if proper technique is not used. To avoid back injuries, keep your back vertical and never over-exert yourself.

**OVERLOADING.** Overloading this machine can cause injury from flying parts if breakage occurs. Do not exceed the machine capacities.

### **WARNING**

Like all machinery there is potential danger when operating this machine. Accidents are frequently caused by lack of familiarity or failure to pay attention. Use this machine with respect and caution to decrease the risk of operator injury. If normal safety precautions are overlooked or ignored, serious personal injury may occur.

### **CAUTION**

No list of safety guidelines can be complete. Every shop environment is different. Always consider safety first, as it applies to your individual working conditions. Use this and other machinery with caution and respect. Failure to do so could result in serious personal injury, damage to equipment, or poor work results.





# SECTION 2: SETUP

## Unpacking

Your machine was carefully packaged for safe transportation. Remove the packaging materials from around your machine and inspect it. If you discover any damage, *please call us immediately at (570) 546-9663 for advice.*

Save the containers and all packing materials for possible inspection by the carrier or its agent. *Otherwise, filing a freight claim can be difficult.*

When you are completely satisfied with the condition of your shipment, inventory the contents.



## Needed for Setup

The following are needed to complete the setup process, but are not included with your machine.

Description	Qty
• Cleaner/Degreaser ( <b>Page 8</b> ) .....	As Needed
• Disposable Shop Rags.....	As Needed
• Sturdy Workbench.....	1
• Vise Secured to Workbench.....	1
• Wrench 17mm .....	1
• Hex Wrench 2.5mm.....	1
• Hex Wrench 6mm.....	1

## Inventory

The following is a description of the main components shipped with your machine. Lay the components out to inventory them.

If any non-proprietary parts are missing (e.g. a nut or a washer), we will gladly replace them; or for the sake of expediency, replacements can be obtained at your local hardware store.

Shipping Inventory: (Figure 1)	Qty
A. Brake Assembly .....	1
B. Operating lever w/Set Screw M5-.8 x 8.....	1
C. Lever Shaft .....	1

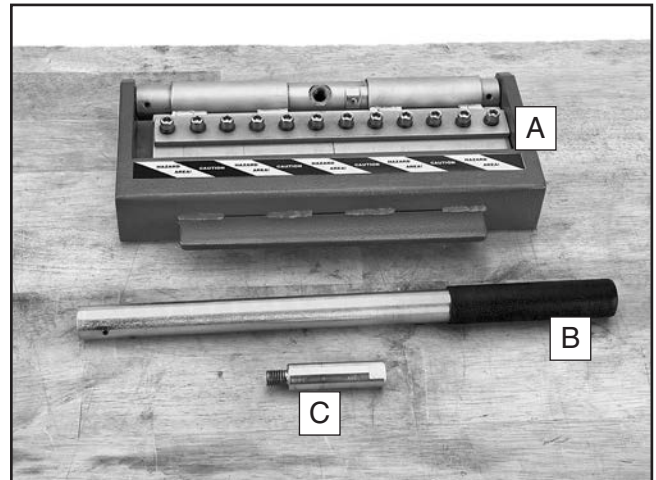

Figure 1. Shipping inventory.

**NOTICE**  
 If you cannot find an item on this list, carefully check the machine and the packaging materials. Some of these items may be pre-installed for shipping or become misplaced during unpacking.



# Cleanup

The unpainted surfaces of your machine are coated with a heavy-duty rust preventative that prevents corrosion during shipment and storage. This rust preventative works extremely well, but it will take a little time clean.

Always follow the manufacturer's instructions with any cleaning product you use and make sure you work in a well-ventilated area to minimize exposure to toxic fumes.

## Before cleaning, gather the following:

- Disposable Rags
- Cleaner/degreaser (WD-40 works well)
- Safety glasses & disposable gloves
- Plastic paint scraper (optional)
- Hex Wrench 6mm
- Quality metal protectants products like G96® Gun Treatment, SLIPIT®, or Boeshield® T-9 (see **Page 13** for offering from Grizzly).

## Basic steps for removing rust preventative:

1. Put on safety glasses.
2. Remove the fingers (refer to **Page 11** for detailed instructions).
3. Coat the rust preventative with a liberal amount of cleaner/degreaser, then let it soak for 5–10 minutes.
4. Wipe off the surfaces. If your cleaner/degreaser is effective, the rust preventative will wipe off easily. If you have a plastic paint scraper, scrape off as much as you can first, then wipe off the rest with the rag.
5. Repeat **Steps 3–4** as necessary until clean.
6. Apply a thin coat of quality metal protectant to the fingers and other unpainted metal surfaces, then re-install the fingers.

## NOTICE

Avoid chlorine-based solvents, such as acetone or brake parts cleaner, that may damage painted surfaces.

# Site Considerations

## Workbench Load

Refer to **Specifications** on **Page 3** for the weight of your machine. Some workbenches may require additional reinforcement to support both the machine and materials.

## Placement Location

Consider existing and anticipated needs, size of material to be processed through each machine, and space for auxiliary stands, work tables or other machinery when establishing a location for your new machine. See **Figure 2** for the minimum working clearances.

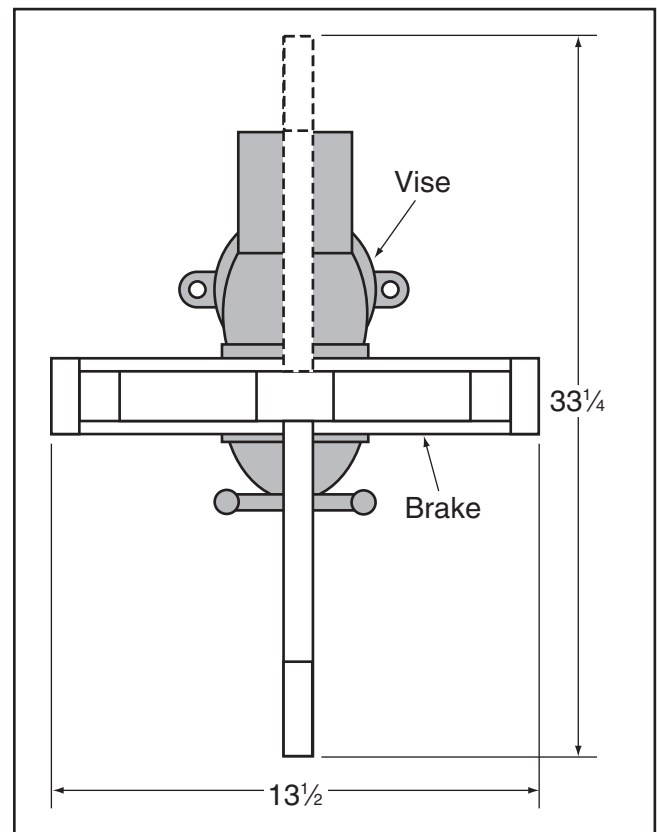

**Figure 2.** Minimum working clearances.



# Assembly

Except for the operating lever, the Model T10726 has been assembled and adjusted at the factory.

## To attach the operating lever:

1. Thread the operating lever shaft (see **Figure 3**) into the eccentric shaft, and tighten it with the wrench.

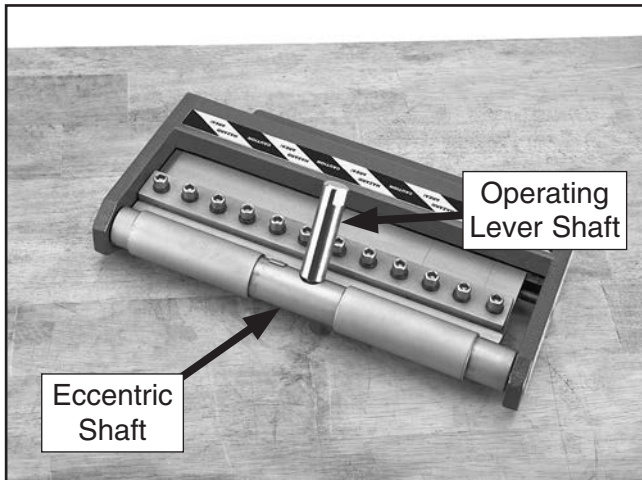

**Figure 3.** Operating lever shaft installed.

2. Slide the operating lever onto the lever shaft (see **Figure 4**), and secure it with the pre-installed set screw.

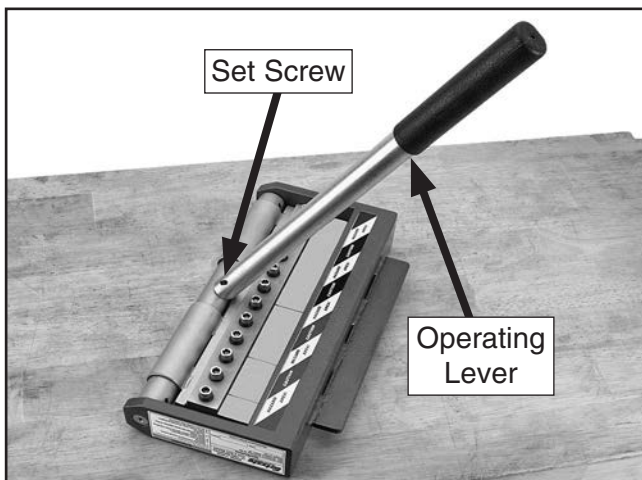

**Figure 4.** Operating lever attached.

# Vise & Workbench Setup

The forces exerted on the brake during operation are substantial. The brake must be firmly secured in a vise (see **Figure 5**) that is solidly attached to a workbench that will support the weight and dynamic pressures of the operation (refer to **Page 12** for workbench and vise options from Grizzly).

Mount the brake by tightening the vise jaws against the lug at the bottom of the brake.

**Note:** Use pieces of cardboard, wood, or padded jaw faces between the vise jaws and the vise lug to prevent surface damage to the brake.



**Figure 5.** Example of Model T10726 secured in vise mounted to a workbench.

## ⚠ CAUTION

Make sure the workbench that the brake will be mounted on is stable and can support the weight of the tool, the workpiece, and the forces exerted during operation.



# SECTION 3: OPERATIONS

## **! WARNING**

Damage to your eyes or hands could result from using this brake without proper protective gear. Always wear safety glasses and leather gloves when operating this brake.

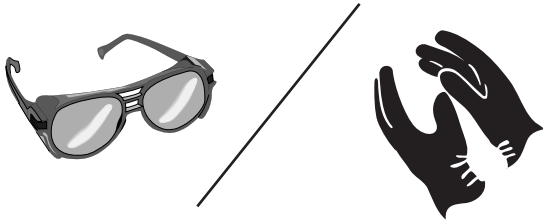

## **NOTICE**

If you are not experienced with this type of machine, WE STRONGLY RECOMMEND that you seek additional training outside of this manual. Read books/magazines or get formal training before beginning any projects. Regardless of the content in this section, Grizzly Industrial will not be held liable for accidents caused by lack of training.

## Basic Bending

The Model T10726 bends mild steel up to 22 gauge at angles up to 90°.

To perform a basic bending operation:

1. Clean away any debris from the workpiece.
2. Use a pencil or scribe to mark the bending location.
3. Lift the operating lever and center the workpiece under the fingers and directly over the mark you made in **Step 2** (see **Figure 6**).

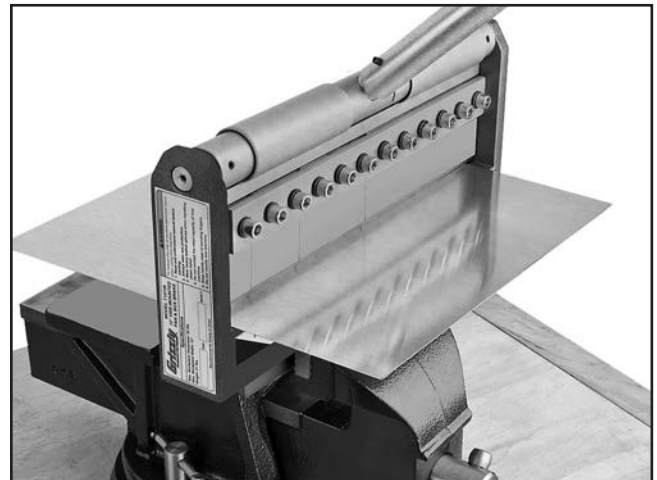
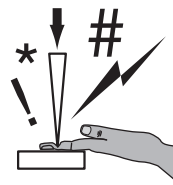

Figure 6. Workpiece positioned under fingers.



## **! CAUTION**

Keep your fingers and hands away from the fingers during operation to avoid the risk of crushing injuries.



- Slowly lower the operating lever until the bend in the workpiece reaches the desired angle (see **Figure 7** for an example).

**Note:** Make sure the finger points are directly over the finger receiver groove as you lower the lever.



**Figure 7.** Example of a 90° bend.

- Lift the operating lever to raise the fingers, remove the bent workpiece, then lower the fingers back into the finger receiver.

## NOTICE

If a pan or box is desired, refer to the next subsection to position the fingers for this operation.

## Removing/Spacing Fingers

The fingers can be spaced for pan and box operations. This involves removing one or more fingers so that the others can be properly spaced.

Tool Needed	Qty
Hex Wrench 6mm.....	1

### To remove and space fingers:

- Lift the operating lever to raise the fingers.

- From the rear of the brake, carefully push the fingers forward, as shown in **Figure 8**, then slowly lower the lever behind the brake. The fingers should clear the front of the frame as they are lowered.

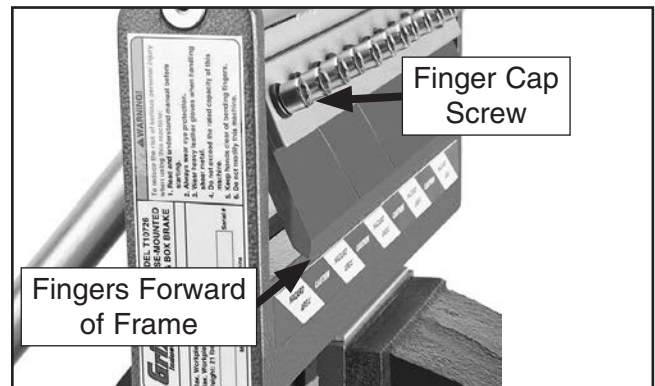

**Figure 8.** Fingers positioned forward of frame.

- Remove the cap screw(s) that secure the finger, then pull the fingers from the clamps.

**Note:** It may be necessary to loosen the first cap screw on the finger(s) adjacent to the one you are removing to release the clamping pressure.

- Position the fingers in an arrangement for the length or width of the desired bend (see **Figure 9** for an example).

**Note:** As you move or replace fingers, make sure they are aligned with each other (see **Finger Alignment on Page 16** for detailed instructions).

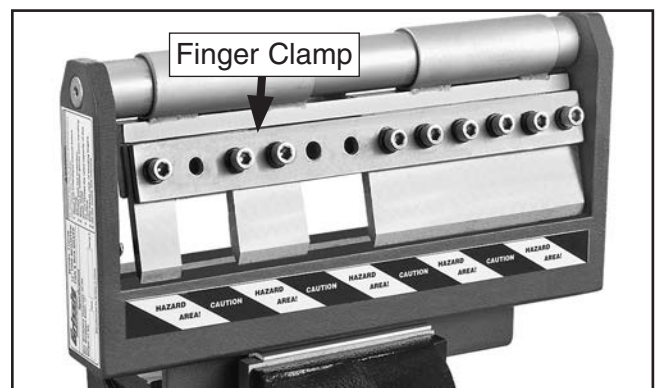

**Figure 9.** Example of finger spacing.

- Raise the fingers up, then lower them back into the finger receiver.



# SECTION 4: ACCESSORIES

## **! WARNING**

Installing unapproved accessories may cause machine to malfunction, resulting in serious personal injury or machine damage. To reduce this risk, only install accessories recommended for this machine by Grizzly.

## **NOTICE**

Refer to our website or latest catalog for additional recommended accessories.

### **Heavy-Duty Bench Vises with Anvils**

**G7059—5", 45 lbs.**

**G7060—6", 68 lbs.**

These tough vises are ideal for all bench work applications. Large machined center slide keeps jaws aligned under maximum pressure. Other features include large Acme screws, anvil faces, and 0°–90° swivel.



**Figure 10.** Heavy-Duty Bench Vise with Anvil.

### **G5618—Deburring Tool with two Blades**

The quickest tool for smoothing freshly sheared metal edges. Comes with two blades, one for steel and aluminum and one for brass and cast iron.

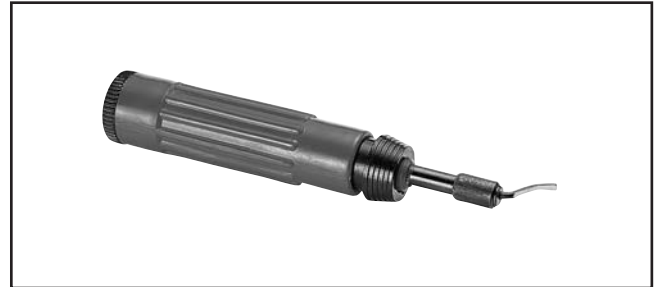

**Figure 11.** Model G5618 Deburring tool.

### **Super Heavy-Duty Birch Workbench**

**H8361—60" x 30"**

**H8362—72" x 36"**

Sized to fit the needs of any shop, these Super Heavy-Duty Birch Workbenches have solid 3" thick tops that stand 38" above the floor. The end vise measures 14<sup>3</sup>/<sub>4</sub>" wide (H8361) or 17<sup>3</sup>/<sub>4</sub>" wide (H8362) and has a 7" maximum capacity. Stable laminated birch provides strength and durability. You'll be proud to have this workbench in your shop!



**Figure 12.** Super Heavy-Duty Birch Workbench.

**order online at [www.grizzly.com](http://www.grizzly.com) or call 1-800-523-4777**



## Basic Eye Protection

- T20501—Face Shield Crown Protector 4"
- T20502—Face Shield Crown Protector 7"
- T20503—Face Shield Window
- T20452—"Kirova" Anti-Reflective S. Glasses
- T20451—"Kirova" Clear Safety Glasses
- H0736—Shop Fox® Safety Glasses
- H7194—Bifocal Safety Glasses 1.5
- H7195—Bifocal Safety Glasses 2.0
- H7196—Bifocal Safety Glasses 2.5



Figure 13. Assortment of basic eye protection.

## Recommended Metal Protectants

- G5562—SLIPIT® 1 Qt. Gel
- G5563—SLIPIT® 12 oz Spray
- G2871—Boeshield® T-9 12 oz Spray
- G2870—Boeshield® T-9 4 oz Spray
- H3788—G96® Gun Treatment 12 oz Spray
- H3789—G96® Gun Treatment 4.5 oz Spray



Figure 14. Recommended products for protecting unpainted cast iron/steel part on machinery.

## Bostitch Compound Action Aviations Snips

T22298—Straight

T22299—Left

T22300—Right

These 10" Aviation Snips are designed for cutting heavy stock in a straight, left, or right cutting direction. Developed with TiN-coated cutting blades to reduce wear and extend blade life, they cut up to 18 gauge cold-rolled steel or 23 gauge stainless steel. The patented flush-mounted side hardware also helps prevent metal from catching while cutting. These snips meet or exceed ANSI standards.



Figure 15. Bostitch Compound Aviation Snips.

**order online at [www.grizzly.com](http://www.grizzly.com) or call 1-800-523-4777**



# SECTION 5: MAINTENANCE

Regular maintenance on the Model T10726 will ensure its optimum performance. Make a habit of inspecting your brake each time you use it.

**There are three main areas to maintain on the Model T10726:**

- **Fingers and Finger Receiver.** After handling the fingers for removal, spacing, or re-installation, always apply a quality metal protectant to the fingers and finger receiver (see **Page 13** for offerings from Grizzly) to prevent corrosion.

When storing the brake for long periods of time, make a habit of occasionally re-applying the metal protectant as directed above.

- **Eccentric Shaft Rod.** Periodically or if the up-and-down finger movement becomes stiff, apply a couple of drops of light machine oil to the eccentric shaft rods on each end of the eccentric shaft (see **Figure 16**). The rods are accessible between the eccentric shaft and the roller brackets. Rotate the lever front-to-back several times to distribute the oil, then wipe away any excess.

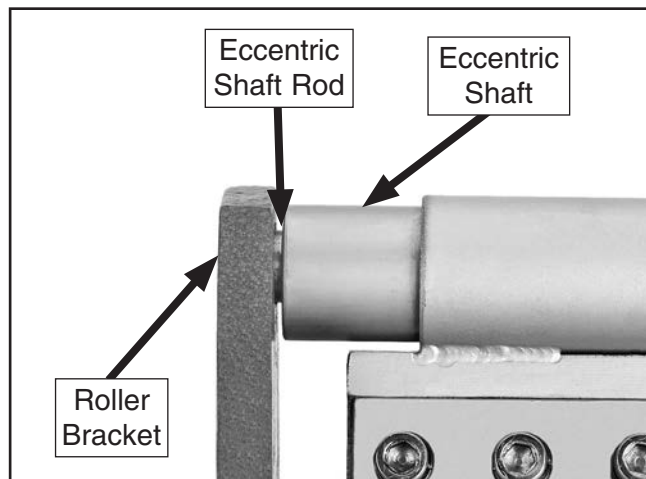

**Figure 16.** Eccentric shaft rod between the eccentric shaft and the frame.

- **Finger Clamp Sleeve Lubrication.** To reduce wear, periodically apply a couple of drops of light machine oil to each end of the finger clamp sleeves (see **Figure 17**), then slide the sleeves side-to-side several times to distribute the oil. Wipe away any excess oil.

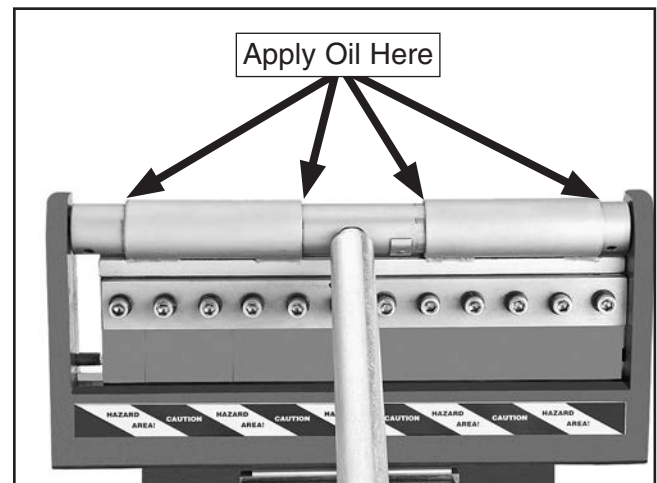

**Figure 17.** Finger clamp lubrication points.





# SECTION 6: SERVICE

Review the troubleshooting and procedures in this section if a problem develops with your machine. If you need replacement parts or additional help with a procedure, call our Technical Support at (570) 546-9663.

**Note:** Please gather the serial number and manufacture date of your machine before calling.

## Troubleshooting

Symptom	Possible Cause	Possible Solution
Heavy resistance during bends.	<ol style="list-style-type: none"><li>1. Machine capacities are exceeded.</li><li>2. Fingers not aligned with finger receiver groove.</li></ol>	<ol style="list-style-type: none"><li>1. Use sheet metal that does not exceed 22 gauge mild steel.</li><li>2. Make sure fingers are aligned with finger receiver groove as fingers are lowered for bend.</li></ol>
Bend radius is not consistent across workpiece.	<ol style="list-style-type: none"><li>1. Machine capacities are exceeded.</li><li>2. Bottom of fingers not aligned with each other.</li></ol>	<ol style="list-style-type: none"><li>1. Use sheet metal that does not exceed 22 gauge mild steel.</li><li>2. Make sure fingers are firmly seated in finger clamps and the finger points are aligned with each other.</li></ol>
Point of fingers are chipping or rolling.	<ol style="list-style-type: none"><li>1. Fingers not aligned with finger receiver groove.</li><li>2. Machine capacities are exceeded.</li></ol>	<ol style="list-style-type: none"><li>1. Make sure fingers are aligned with finger receiver groove as fingers are lowered for bend. Replace fingers if damaged.</li><li>2. Use sheet metal that does not exceed 22 gauge mild steel. Replace fingers if damaged.</li></ol>
Workpiece shows scoring marks or scratches after bend.	<ol style="list-style-type: none"><li>1. Debris on fingers or finger receiver.</li><li>2. Fingers or finger receiver has scratches.</li></ol>	<ol style="list-style-type: none"><li>1. Clean fingers and finger receiver (<b>Page 14</b>).</li><li>2. Polish out scratches, and apply tape on the workpiece at the bend locations for protection.</li></ol>



# Finger Alignment

To produce straight bends, the finger points (see **Figure 18**) must all be aligned evenly.

When moving or re-installing the fingers, there is play in the vertical positioning which can be used to align the fingers.

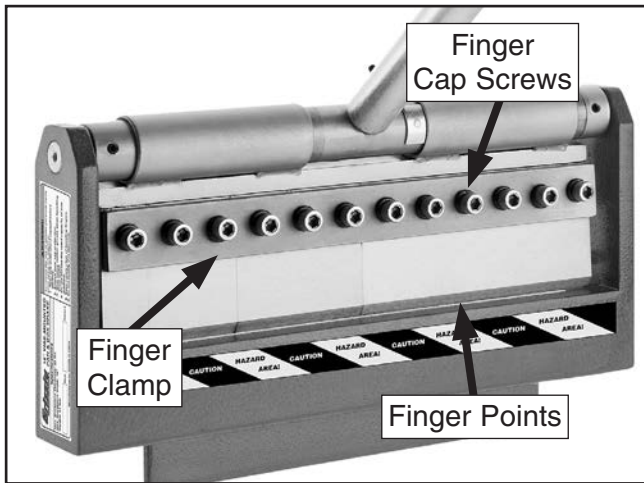

**Figure 18.** Finger points and cap screws.

Look along the length of the fingers from the side to identify any finger point that is not aligned with the rest.

Tool Needed	Qty
Hex Wrench 6mm.....	1

### To align the finger points:

1. Loosen, but do not remove, the cap screws that secures the finger.

**Note:** *It may be necessary to also loosen the cap screws on each side of the finger to relieve the pressure from the finger clamp.*

2. Apply upward pressure to the finger to firmly seat it into the finger clamp.
3. Observe the alignment of the finger points from the side again. If necessary, repeat this procedure to bring all fingers into alignment.





# Labels

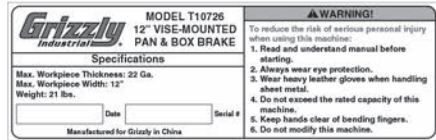

31



Front View

32



33



34

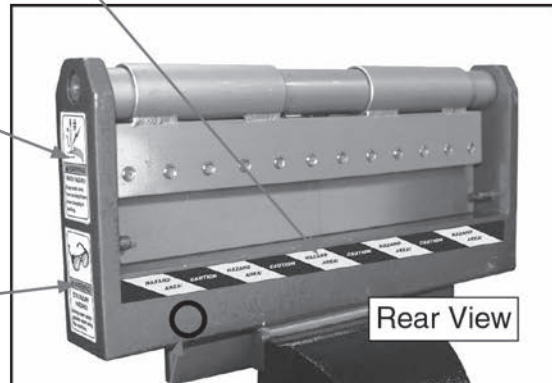

Rear View

35

REF	PART #	DESCRIPTION
31	PT10726031	ID LABEL
32	PT10726032	HAZARD STRIP LABEL
33	PT10726033	PINCH HAZARD LABEL

REF	PART #	DESCRIPTION
34	PT10726034	EYE INJURY HAZARD LABEL
35	PPAINT-01	GRIZZLY GREEN TOUCH-UP PAINT

## WARNING

Safety labels help reduce the risk of serious injury caused by machine hazards. If any label comes off or becomes unreadable, the owner of this machine **MUST** replace it in the original location before resuming operations. For replacements, contact (800) 523-4777 or [www.grizzly.com](http://www.grizzly.com).





# WARRANTY CARD

Name \_\_\_\_\_  
 Street \_\_\_\_\_  
 City \_\_\_\_\_ State \_\_\_\_\_ Zip \_\_\_\_\_  
 Phone # \_\_\_\_\_ Email \_\_\_\_\_  
 Model # \_\_\_\_\_ Order # \_\_\_\_\_ Serial # \_\_\_\_\_

The following information is given on a voluntary basis. It will be used for marketing purposes to help us develop better products and services. **Of course, all information is strictly confidential.**

1. How did you learn about us?

Advertisement                       Friend                       Catalog  
 Card Deck                               Website                       Other:

2. Which of the following magazines do you subscribe to?

<input type="checkbox"/> Cabinetmaker & FDM	<input type="checkbox"/> Popular Science	<input type="checkbox"/> Wooden Boat
<input type="checkbox"/> Family Handyman	<input type="checkbox"/> Popular Woodworking	<input type="checkbox"/> Woodshop News
<input type="checkbox"/> Hand Loader	<input type="checkbox"/> Precision Shooter	<input type="checkbox"/> Woodsmith
<input type="checkbox"/> Handy	<input type="checkbox"/> Projects in Metal	<input type="checkbox"/> Woodwork
<input type="checkbox"/> Home Shop Machinist	<input type="checkbox"/> RC Modeler	<input type="checkbox"/> Woodworker West
<input type="checkbox"/> Journal of Light Cont.	<input type="checkbox"/> Rifle	<input type="checkbox"/> Woodworker's Journal
<input type="checkbox"/> Live Steam	<input type="checkbox"/> Shop Notes	<input type="checkbox"/> Other:
<input type="checkbox"/> Model Airplane News	<input type="checkbox"/> Shotgun News	
<input type="checkbox"/> Old House Journal	<input type="checkbox"/> Today's Homeowner	
<input type="checkbox"/> Popular Mechanics	<input type="checkbox"/> Wood	

3. What is your annual household income?

\$20,000-\$29,000                       \$30,000-\$39,000                       \$40,000-\$49,000  
 \$50,000-\$59,000                       \$60,000-\$69,000                       \$70,000+

4. What is your age group?

20-29                                       30-39                                       40-49  
 50-59                                       60-69                                       70+

5. How long have you been a woodworker/metalworker?

0-2 Years                       2-8 Years                       8-20 Years                       20+ Years

6. How many of your machines or tools are Grizzly?

0-2                       3-5                       6-9                       10+

7. Do you think your machine represents a good value?

Yes                       No

8. Would you recommend Grizzly Industrial to a friend?

Yes                       No

9. Would you allow us to use your name as a reference for Grizzly customers in your area?

**Note:** We never use names more than 3 times.                       Yes                       No

10. Comments: \_\_\_\_\_  
 \_\_\_\_\_  
 \_\_\_\_\_  
 \_\_\_\_\_

CUT ALONG DOTTED LINE

FOLD ALONG DOTTED LINE

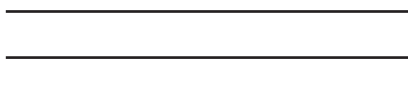

Place  
Stamp  
Here



GRIZZLY INDUSTRIAL, INC.  
P.O. BOX 2069  
BELLINGHAM, WA 98227-2069



FOLD ALONG DOTTED LINE

Send a Grizzly Catalog to a friend:

Name_____
Street_____
City_____ State_____ Zip_____

TAPE ALONG EDGES--PLEASE DO NOT STAPLE

# WARRANTY & RETURNS

---

Grizzly Industrial, Inc. warrants every product it sells for a period of **1 year** to the original purchaser from the date of purchase. This warranty does not apply to defects due directly or indirectly to misuse, abuse, negligence, accidents, repairs or alterations or lack of maintenance. This is Grizzly's sole written warranty and any and all warranties that may be implied by law, including any merchantability or fitness, for any particular purpose, are hereby limited to the duration of this written warranty. We do not warrant or represent that the merchandise complies with the provisions of any law or acts unless the manufacturer so warrants. In no event shall Grizzly's liability under this warranty exceed the purchase price paid for the product and any legal actions brought against Grizzly shall be tried in the State of Washington, County of Whatcom.

We shall in no event be liable for death, injuries to persons or property or for incidental, contingent, special, or consequential damages arising from the use of our products.

To take advantage of this warranty, contact us by mail or phone and give us all the details. We will then issue you a "Return Number," which must be clearly posted on the outside as well as the inside of the carton. We will not accept any item back without this number. Proof of purchase must accompany the merchandise.

The manufacturers reserve the right to change specifications at any time because they constantly strive to achieve better quality equipment. We make every effort to ensure that our products meet high quality and durability standards and we hope you never need to use this warranty.

Please feel free to write or call us if you have any questions about the machine or the manual.

Thank you again for your business and continued support. We hope to serve you again soon.

# *grizzly.com*<sup>®</sup>

**TOOL WEBSITE**

Buy Direct and Save with Grizzly<sup>®</sup> – Trusted, Proven and a Great Value!  
~Since 1983~

*Visit Our Website Today For  
Current Specials!*

**ORDER  
24 HOURS A DAY!  
1-800-523-4777**





## Free Manuals Download Website

<http://myh66.com>

<http://usermanuals.us>

<http://www.somanuals.com>

<http://www.4manuals.cc>

<http://www.manual-lib.com>

<http://www.404manual.com>

<http://www.luxmanual.com>

<http://aubethermostatmanual.com>

Golf course search by state

<http://golfingnear.com>

Email search by domain

<http://emailbydomain.com>

Auto manuals search

<http://auto.somanuals.com>

TV manuals search

<http://tv.somanuals.com>