

# *Grizzly* *Industrial, Inc.*®

## **18" WIDE BELT SANDER MODEL G0527 INSTRUCTION MANUAL**



COPYRIGHT © JUNE 2003 BY GRIZZLY INDUSTRIAL, INC.  
**WARNING: NO PORTION OF THIS MANUAL MAY BE REPRODUCED IN ANY SHAPE  
OR FORM WITHOUT THE WRITTEN APPROVAL OF GRIZZLY INDUSTRIAL, INC.**  
#509703624 PRINTED IN TAIWAN

# WARNING

Some dust created by power sanding, sawing, grinding, drilling, and other construction activities contains chemicals known to the State of California to cause cancer, birth defects or other reproductive harm. Some examples of these chemicals are:

- Lead from lead-based paints.
- Crystalline silica from bricks, cement, and other masonry products.
- Arsenic and chromium from chemically treated lumber.

Your risk from these exposures varies, depending on how often you do this type of work. To reduce your exposure to these chemicals: work in a well ventilated area, and work with approved safety equipment, such as those dust masks that are specially designed to filter out microscopic particles.

# Table Of Contents

<b>SECTION 1: SAFETY</b> .....	<b>2</b>
Safety Instructions For Power Tools .....	2
Additional Safety For Wide Belt Sanders.....	4
<b>SECTION 2: INTRODUCTION</b> .....	<b>5</b>
Commentary.....	5
<b>SECTION 3: CIRCUIT REQUIREMENTS</b> .....	<b>6</b>
Amperage Draw .....	6
Circuit Breaker .....	6
Connection Type .....	6
Circuit Capacity .....	6
Minimum Cord Size .....	7
Grounding .....	7
Extension Cords.....	7
<b>SECTION 4: MACHINE FEATURES</b> .....	<b>8</b>
External Features .....	8
Control Panel .....	9
Access Doors .....	10
<b>SECTION 5: SET UP</b> .....	<b>12</b>
G0527 Inventory.....	12
Hardware Recognition Chart .....	13
Clean Up .....	14
Site Considerations .....	14
Beginning Assembly.....	15
Floor Mounting .....	15
Air Line Hook-Up .....	16
Dust Collection .....	16
Sanding Belt.....	17
Pressure Rollers.....	18
Recommended Adjustments .....	19
<b>SECTION 6: OPERATIONS</b> .....	<b>20</b>
Before Sanding .....	20
Choosing Sandpaper .....	20
Table Movement .....	21
Adjusting Feed Rate .....	21
Amperage Meter .....	22
Sanding Workpiece .....	22
<b>SECTION 7: MAINTENANCE</b> .....	<b>23</b>
General .....	23
Schedule .....	23
Servicing Brakes .....	24
Air Circuit Filters.....	25
Clean Sanding Belts .....	25
Maintenance Log .....	26
<b>SECTION 8: SERVICE ADJUSTMENTS</b> .....	<b>27</b>
Calibration .....	27
Feed Belt Tension .....	28
Feed Belt Tracking.....	28
Belt Oscillation .....	29
Table Parallelism .....	30
Pressure Rollers.....	31
V-Belt Adjustment .....	32
Air System .....	32
Air Line Circuit .....	33
Service Log .....	34
<b>SECTION 9: REFERENCE INFO</b> .....	<b>35</b>
General .....	35
Aftermarket Accessories .....	35
G0527 Machine Data Sheet.....	36
Parts Diagrams & Lists .....	37
Machine Troubleshooting.....	53
Sanding Troubleshooting .....	54
Wiring Diagrams.....	55
Notes .....	57
Warranty & Returns .....	58

# SECTION 1: SAFETY

## WARNING

### For Your Own Safety Read Instruction Manual Before Operating This Equipment

The purpose of safety symbols is to attract your attention to possible hazardous conditions. This manual uses a series of symbols and signal words which are intended to convey the level of importance of the safety messages. The progression of symbols is described below. Remember that safety messages by themselves do not eliminate danger and are not a substitute for proper accident prevention measures.



Indicates an imminently hazardous situation which, if not avoided, WILL result in death or serious injury.



Indicates a potentially hazardous situation which, if not avoided, COULD result in death or serious injury.



Indicates a potentially hazardous situation which, if not avoided, MAY result in minor or moderate injury. It may also be used to alert against unsafe practices.

**NOTICE**

This symbol is used to alert the user to useful information about proper operation of the equipment.

## WARNING

### Safety Instructions For Power Tools

1. **KEEP GUARDS IN PLACE** and in working order.
2. **REMOVE ADJUSTING KEYS AND WRENCHES.** Form a habit of checking to see that keys and adjusting wrenches are removed from tool before turning on.
3. **KEEP WORK AREA CLEAN.** Cluttered areas and benches invite accidents.
4. **NEVER USE IN DANGEROUS ENVIRONMENT.** DO NOT use power tools in damp or wet locations, or where any flammable or noxious fumes may exist. Keep work area well lighted.
5. **KEEP CHILDREN AND VISITORS AWAY.** All children and visitors should be kept at a safe distance from work area.
6. **MAKE WORKSHOP CHILD PROOF** with padlocks, master switches, or by removing starter keys.
7. **NEVER FORCE TOOL.** It will do the job better and safer at the rate for which it was designed.
8. **USE RIGHT TOOL.** DO NOT force tool or attachment to do a job for which it was not designed.

# WARNING

## Safety Instructions For Power Tools

- 9. USE PROPER EXTENSION CORD.** Make sure your extension cord is in good condition. Conductor size should be in accordance with the chart below. The amperage rating should be listed on the motor or tool nameplate. An undersized cord will cause a drop in line voltage resulting in loss of power and overheating. Your extension cord must also contain a ground wire and plug pin. Always repair or replace extension cords if they become damaged.

Minimum Gauge for Extension Cords

AMP RATING	LENGTH		
	25ft	50ft	100ft
0-6	16	16	16
7-10	16	16	14
11-12	16	16	14
13-16	14	12	12
17-20	12	12	10
21-30	10	10	No

- 10. WEAR PROPER APPAREL.** DO NOT wear loose clothing, gloves, neckties, rings, bracelets, or other jewelry which may get caught in moving parts. Non-slip footwear is recommended. Wear protective hair covering to contain long hair.
- 11. ALWAYS USE SAFETY GLASSES.** Also use face or dust mask if cutting operation is dusty. Everyday eyeglasses only have impact resistant lenses, they are NOT safety glasses.
- 12. SECURE WORK.** Use clamps or a vise to hold work when practical. It's safer than using your hand and frees both hands to operate tool.
- 13. DO NOT OVER-REACH.** Keep proper footing and balance at all times.
- 14. MAINTAIN TOOLS WITH CARE.** Keep tools sharp and clean for best and safest performance. Follow instructions for lubricating and changing accessories.

- 15. USE RECOMMENDED ACCESSORIES.** Consult the owner's manual for recommended accessories. The use of improper accessories may cause risk of injury.
- 16. REDUCE THE RISK OF UNINTENTIONAL STARTING.** On machines with magnetic contact starting switches there is a risk of starting if the machine is bumped or jarred. Always disconnect from power source before adjusting or servicing. Make sure switch is in OFF position before reconnecting.
- 17. CHECK DAMAGED PARTS.** Before further use of the tool, a guard or other part that is damaged should be carefully checked to determine that it will operate properly and perform its intended function. Check for alignment of moving parts, binding of moving parts, breakage of parts, mounting, and any other conditions that may affect its operation. A guard or other part that is damaged should be properly repaired or replaced.
- 18. NEVER LEAVE TOOL RUNNING UNATTENDED. TURN POWER OFF.** DO NOT leave tool until it comes to a complete stop.
- 19. NEVER OPERATE A MACHINE WHEN TIRED, OR UNDER THE INFLUENCE OF DRUGS OR ALCOHOL.** Full mental alertness is required at all times when running a machine.
- 20. NEVER ALLOW UNSUPERVISED OR UNTRAINED PERSONNEL TO OPERATE THE MACHINE.** Make sure any instructions you give in regards to machine operation are approved, correct, safe, and clearly understood.
- 21. IF AT ANY TIME YOU ARE EXPERIENCING DIFFICULTIES** performing the intended operation, stop using the machine! Then contact our service department or ask a qualified expert how the operation should be performed.

## **WARNING**

# Additional Safety For Wide Belt Sanders

- 1. INFEED/OUTFEED AREA:** DO NOT stand in-line with the infeed or outfeed areas when feeding the workpiece.
- 2. WORKPIECE FEEDING:** DO NOT jam the workpiece into the machine and never feed more than one workpiece at a time.
- 3. CLOTHING:** DO NOT wear loose clothing while operating this machine. Roll up or button sleeves at the cuff.
- 4. NARROW WORKPIECES:** DO NOT sand workpieces narrower than  $\frac{1}{8}$ ".
- 5. THIN WORKPIECES:** DO NOT sand workpieces thinner than  $\frac{1}{8}$ ".
- 6. SHORT WORKPIECES:** DO NOT sand workpieces shorter than 9".
- 7. HANDS:** DO NOT place hands near, or in contact with, sanding drums or conveyor belt during operation.
- 8. MAINTENANCE:** Perform machine inspections and maintenance service at the appropriate time intervals. See *Section 7: Maintenance*.
- 9. POWER DISCONNECT:** Unless specifically stated in the manual, always disconnect the power source from the machine when performing maintenance, adjustments, or assembly. Always read and follow specific safety instructions for each section.
- 10. UNATTENDED MACHINE:** Never leave the machine running unattended.
- 11. SANDPAPER:** Replace sanding belt when it becomes worn.
- 12. FOREIGN MATERIAL:** Always inspect workpiece for nails, staples, knots, and other imperfections that could be dislodged and thrown from the machine during sanding operations.
- 13. DUST COLLECTION:** Never operate the sander without an adequate dust collection system in place and running.
- 14. ALLERGIES:** Certain woods may cause an allergic reaction in people and animals, especially when exposed to fine dust. Make sure you know what type of wood dust you will be exposed to and always wear an approved respirator.
- 15. ACCESS DOORS:** Never perform sanding operations when the side access doors are open.
- 16. UNDERSTAND INSTRUCTIONS:** Never allow unsupervised or untrained personnel to operate the machine. Make sure any instructions you give in regards to machine operation are approved, correct, safe, and clearly understood.

## **WARNING**

Unfamiliarity with this manual could result in serious personal injury. Spend a sufficient amount of time becoming familiar the contents of this manual, including all the safety warnings.

## **WARNING**

No list of safety guidelines can be complete. Operating this machinery may require additional safety precautions specific to your shop environment. Failure to use reasonable caution while operating this machine could result in serious personal injury.

# SECTION 2: INTRODUCTION

---

---

## Commentary

---

---

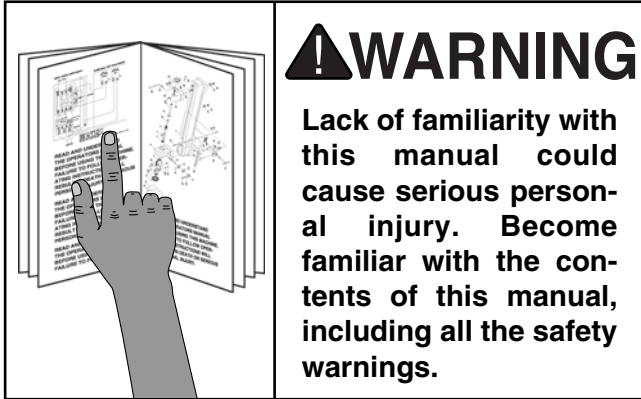

We are proud to offer the Model G0527 18" Wide Belt Sander. This machine is part of a growing Grizzly family of fine woodworking machinery. When used according to the guidelines set forth in this manual, you can expect years of trouble-free, enjoyable operation and proof of Grizzly's commitment to customer satisfaction.

We are pleased to provide this manual with the Model G0527. It was written to guide you through assembly, review safety considerations, and cover general operating procedures. It represents our effort to produce the best documentation possible. If you have any comments regarding this manual, please write to us at the address below:

Grizzly Industrial, Inc.  
% Technical Documentation  
P.O. Box 2069  
Bellingham, WA 98227-2069

Most importantly, we stand behind our machines. If you have any service questions or parts requests, please call or write us at the location listed below.

Grizzly Industrial, Inc.  
1203 Lycoming Mall Circle  
Muncy, PA 17756  
Phone: (570) 546-9663  
Fax: (800) 438-5901  
E-Mail: [techsupport@grizzly.com](mailto:techsupport@grizzly.com)  
Web Site: <http://www.grizzly.com>

The specifications, drawings, and photographs illustrated in this manual represent the Model G0527 as supplied when the manual was prepared. However, owing to Grizzly's policy of continuous improvement, changes may be made at any time with no obligation on the part of Grizzly. For your convenience, we always keep current Grizzly manuals available on our website at [www.grizzly.com](http://www.grizzly.com). Any updates to your machine will be reflected in these manuals as soon as they are complete. Visit our site often to check for the latest updates to this manual!



# SECTION 3: CIRCUIT REQUIREMENTS

---

---

## Amperage Draw

---

---

The Model G0527 has three motors that are wired to operate on a 220V single-phase power source. They will draw the following loads:

Sanding Drum Motor .....30 Amps  
Conveyor Feed Motor .....3.8 Amps  
Elevation Motor .....3 Amps

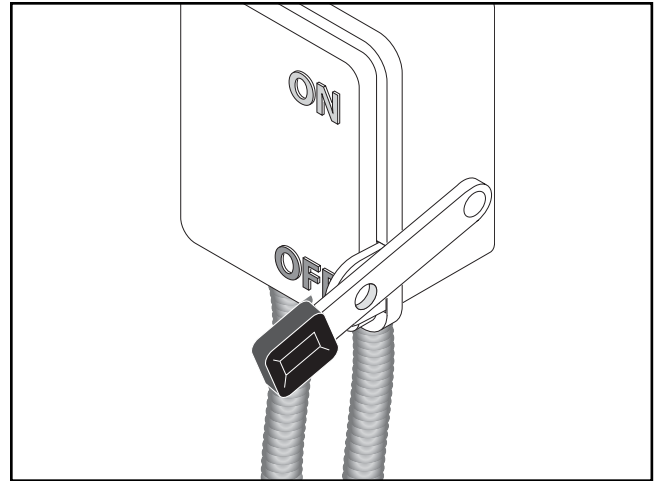

Figure 1. Locking shut-off lever.

---

---

## Circuit Breaker

---

---

Use the following guidelines when choosing a circuit breaker (circuit breakers rated any higher are not adequate to protect the circuit):

Circuit Breaker .....40 Amp, 2 Pole



---

---

## Connection Type

---

---

Because of the high amperage draw from this machine, we recommend that you hardwire it directly to your circuit breaker and install a locking shut-off lever (**Figure 1**) near the machine as a way to quickly disconnect the power.

---

---

## Circuit Capacity

---

---

Always check to see if the wires in your circuit are capable of handling the amperage load from your machine. If you are unsure, consult a qualified electrician.

If you operate this machine on any circuit that is already close to its capacity, it might blow a fuse or trip a circuit breaker. However, if an unusual load does not exist and a power failure still occurs, contact a qualified electrician or our Service Department at (570) 546-9663.





# Minimum Cord Size

For 220V single-phase operation, use the following power cord:

Cord .....2 Pole, 3 Wire  
Gauge .....6

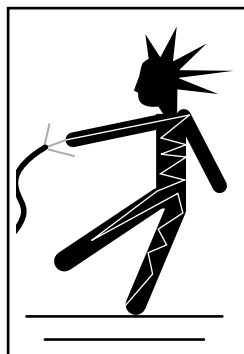

## Grounding

	<p><b>⚠ WARNING</b> Electrocution or a fire can result if the machine is not grounded correctly. Make sure all electrical circuits are grounded. <b>DO NOT</b> use the machine if it is not grounded.</p>
--	---

In the event of an electrical short, grounding provides electric current a path of least resistance to reduce the risk of electrical shock to the operator. Ground the power cord and this machine in accordance with all local codes and ordinances.

Operating this machine when it is not properly grounded can result in electric shock or electrocution.



# Extension Cords

Because of the high amperage draw from this machine, we do not recommend the use of extension cords. Instead, position your equipment near installed wiring to eliminate the need for extension cords.



## ⚠ CAUTION

We have covered some basic electrical requirements for the safe operation of your machine. These requirements are not necessarily comprehensive. You must be sure that your particular electrical configuration complies with local and state codes. Ensure compliance by checking with your local municipality or a licensed electrician.

# SECTION 4: MACHINE FEATURES

## External Features

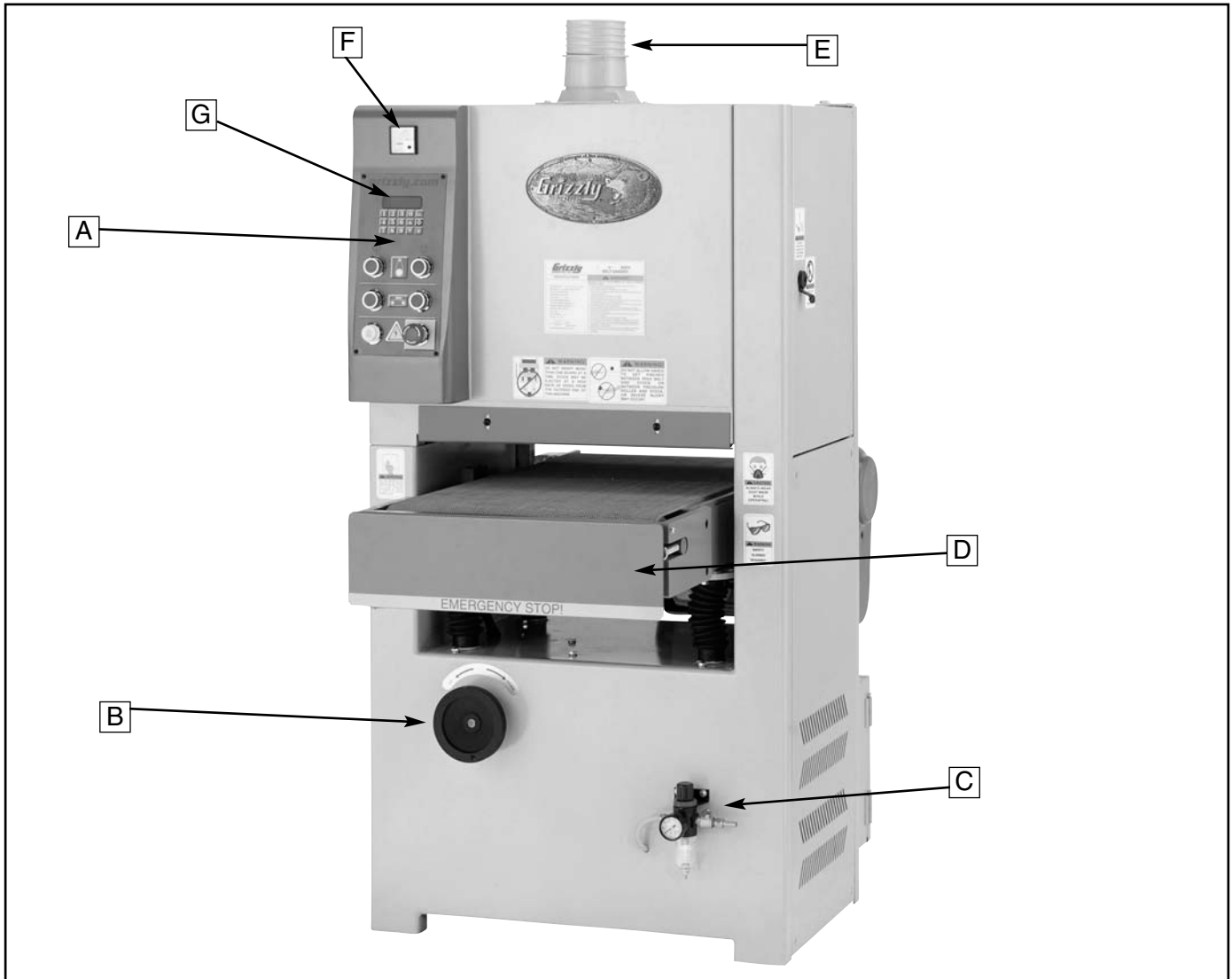
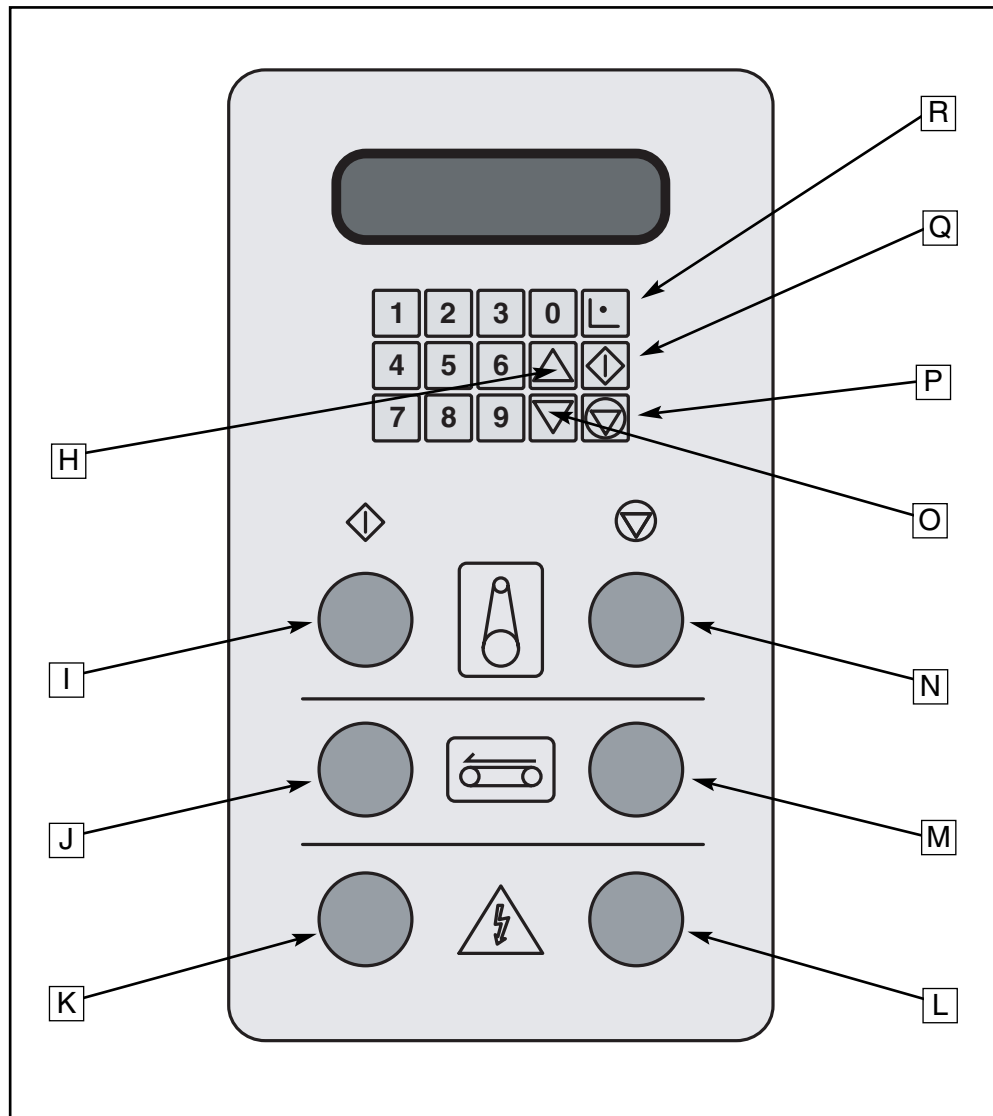

**Figure 2.** Front view.

- A. Control Panel
- B. Table Height Handwheel
- C. Air Regulator/Water Collector
- D. Emergency Stop Bar
- E. Dust Port
- F. Amp (Load) Meter
- G. Digital Readout



# Control Panel



**Figure 3.** Control panel.

- H. TABLE UP Key
- I. SANDING BELT START Button
- J. FEED BELT START Button
- K. Power Light
- L. EMERGENCY STOP Button
- M. FEED BELT STOP Button
- N. SANDING BELT STOP Button
- O. TABLE DOWN Key
- P. FEED BELT STOP Key
- Q. FEED BELT START Key
- R. SET (Enter) Key



# Access Doors

---

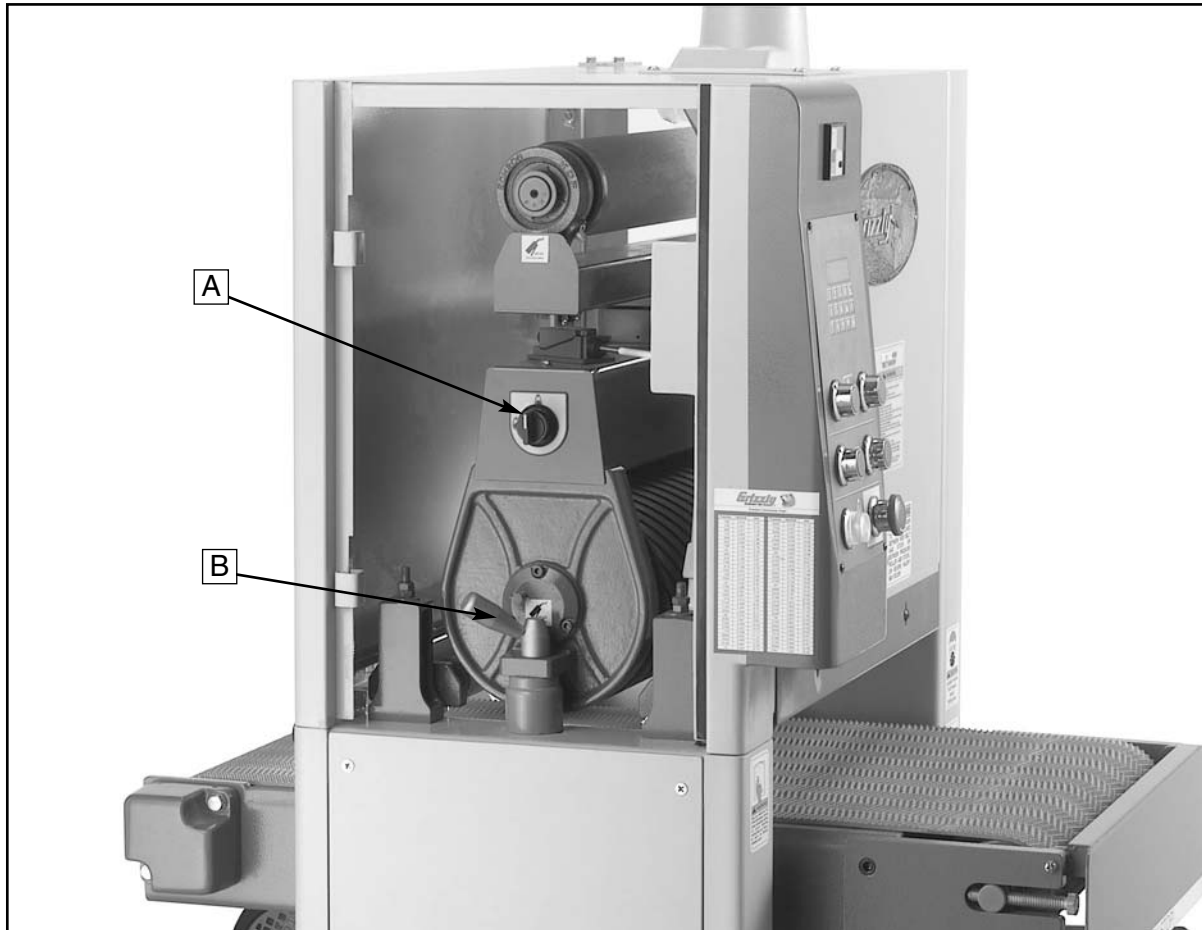

**Figure 4.** Inside the left access door.

- A.** Belt Tension Switch
- B.** Lock Handle Bolt

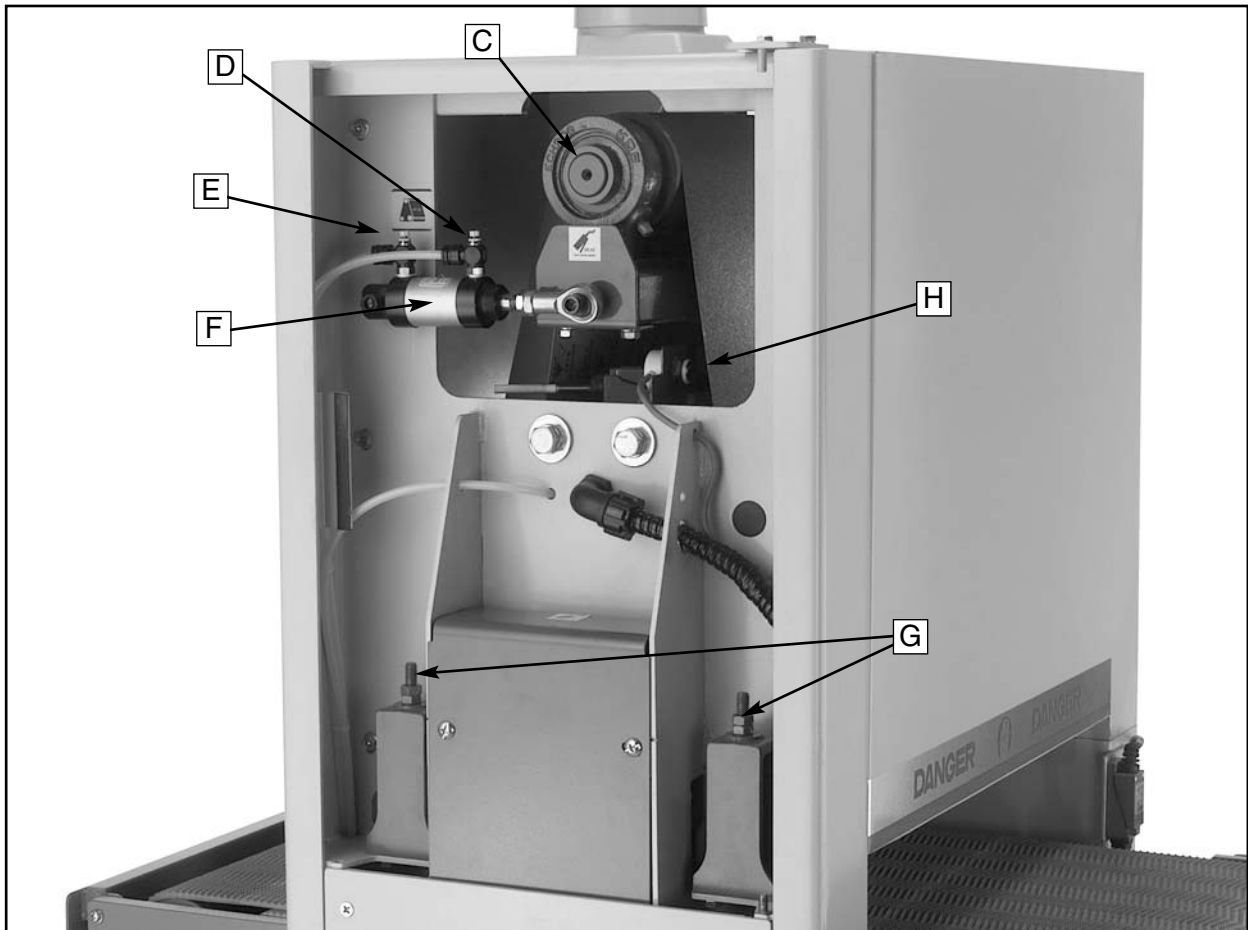
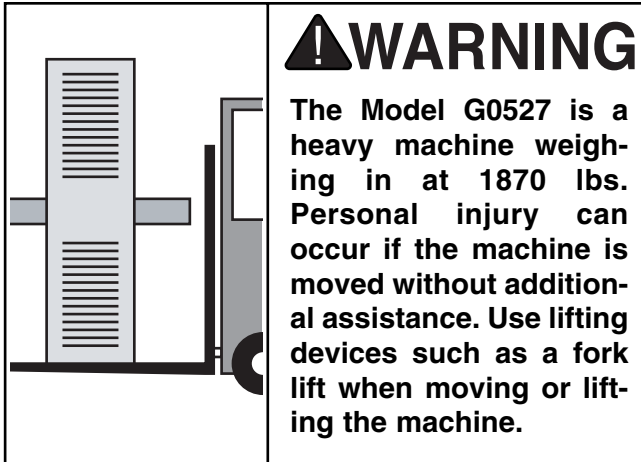

**Figure 5.** Inside the right access door.

- C. Upper Roller
- D. Air Flow Adjustment Knob (Solenoid Expansion)
- E. Air Flow Adjustment Knob (Solenoid Contraction)
- F. Oscillation Solenoid
- G. Pressure Roller Adjustments
- H. Oscillation Electronic Eye



# SECTION 5: SET UP



The Model G0527 was carefully packed when it left our warehouse. If you discover the machine is damaged after you have signed for delivery, immediately call our Service Department at (570) 546-9663.

## **NOTICE**

A parts diagram and parts list are located near the end of the manual. Use the diagram and list to identify missing parts or to supplement the assembly instructions provided in this manual.



## **G0527 Inventory**

The following parts shown in Figure 6 should be enclosed:

- Sanding Unit (Not Pictured)
- 4" Dust Hood
- #100 Grit Sanding Belt
- #150 Grit Sanding Belt
- Tool Box
  - Phillips Head Screwdriver
  - Large Flat Screwdriver
  - Small Flat Screwdriver
  - 8/10mm Open End Wrench
  - 12/14mm Open End Wrench
  - 17/19mm Open End Wrench
  - Metric Allen Wrench Set
  - (2) Door Wrenches



**Figure 6.** G0527 inventory.



# Hardware Recognition Chart

USE THIS CHART TO MATCH UP  
HARDWARE DURING THE ASSEMBLY  
PROCESS!

MEASURE BOLT DIAMETER BY PLACING INSIDE CIRCLE

- #10
- 1/4"
- 5/16"
- 3/8"
- 7/16"
- 1/2"
- 5/8"
- 4mm
- 6mm
- 8mm
- 10mm
- 12mm
- 16mm

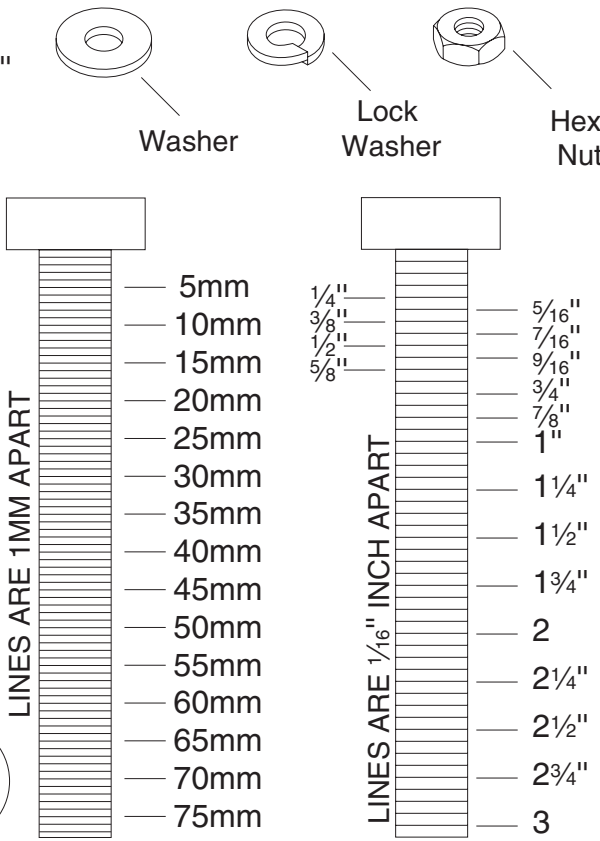
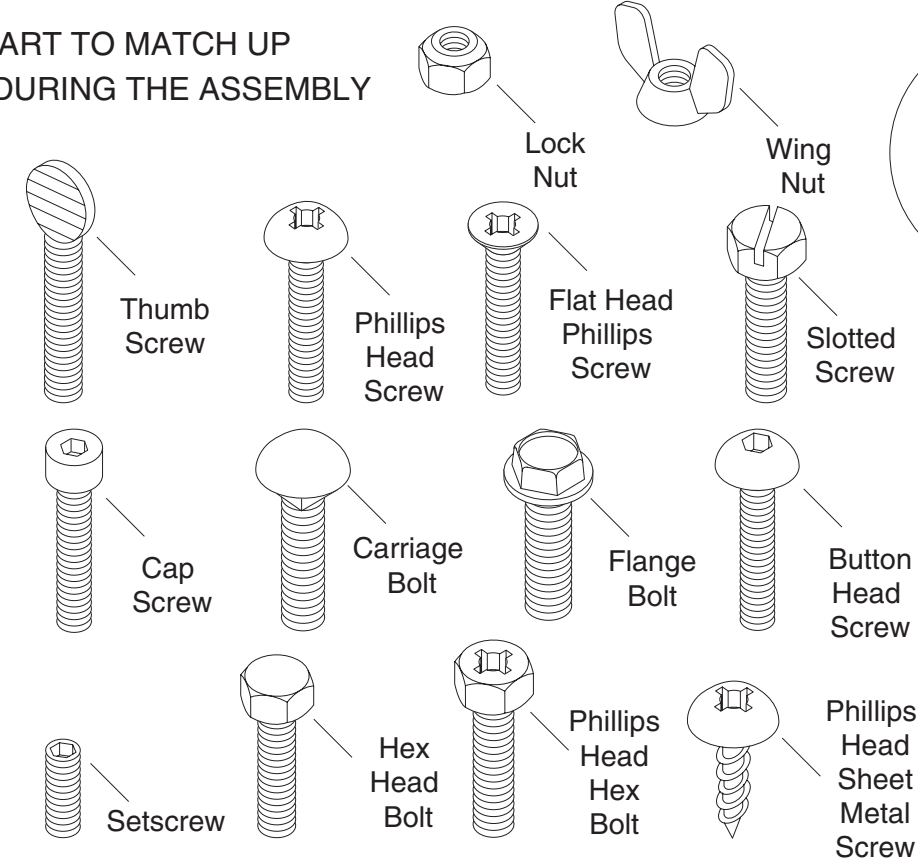

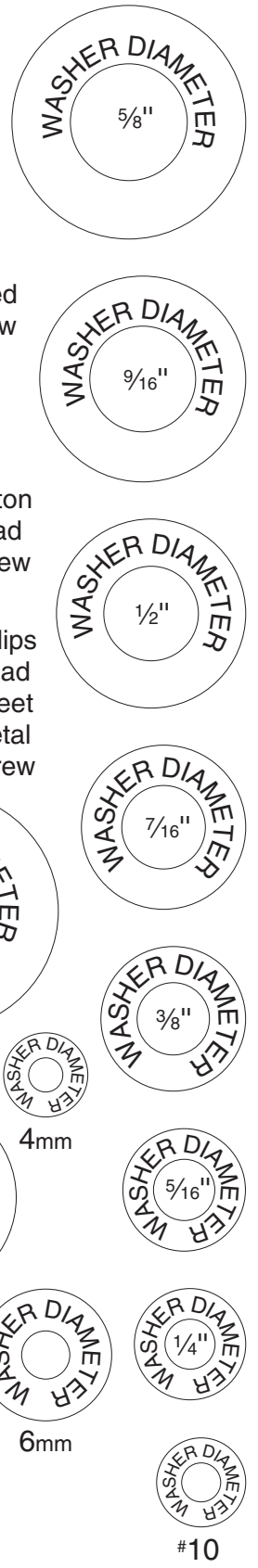

WASHERS ARE MEASURED BY THE INSIDE DIAMETER



# Clean Up

The unpainted surfaces are coated with a waxy oil to protect them from corrosion during shipment. Remove this protective coating with a solvent cleaner or citrus-based degreaser such as Grizzly's G7895 Degreaser. To clean thoroughly, some parts may need to be removed. **For optimum performance from your machine, make sure you clean all moving parts or sliding contact surfaces that are coated.** Avoid chlorine-based solvents as they may damage painted surfaces should they come in contact.

	<p><b>⚠️ WARNING</b> Gasoline and petroleum products have low flash points and could explode if used to clean machinery. <b>DO NOT</b> use gasoline or petroleum products to clean the machinery.</p>
--	---

	<p><b>⚠️ WARNING</b> Smoking near solvents could ignite an explosion or fire and cause serious injury. <b>DO NOT</b> smoke while using solvents.</p>
---	--

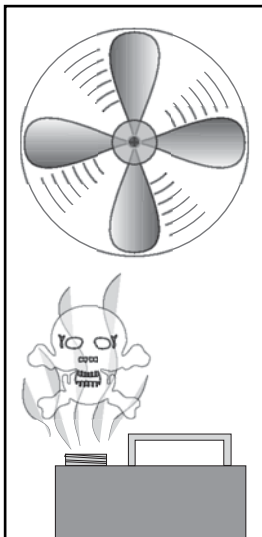
	<p><b>⚠️ WARNING</b> Lack of ventilation while using solvents could cause serious personal health risks, fire, or environmental hazards. Always work in a well ventilated area to prevent the accumulation of dangerous fumes. Supply the work area with a constant source of fresh air.</p>
---	--



# Site Considerations

## Weight Load

The Model G0527 weighs 890 lbs and has a 29" x 16<sup>3</sup>/<sub>4</sub>" footprint. Most shop floors should be sufficient to carry the weight of the machine. Reinforce the floor if you question its ability to support the weight.

## Working Clearance

Working clearances can be thought of as the distances between machines and obstacles that allow safe operation of every machine without limitation. Consider existing and anticipated machine needs, size of material to be processed through each machine, and space for auxiliary stands or work tables. Also, consider the relative position of each machine to one another for efficient material handling.

## Work Area Lightening

Lighting should be bright enough to eliminate shadow and prevent eye strain.

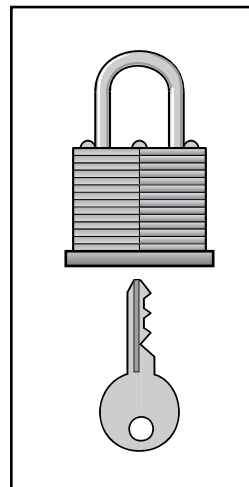
	<p><b>⚠️ WARNING</b> Unsupervised children and visitors inside your shop could receive serious personal injury. Ensure child and visitor safety by keeping all entrances to the shop locked at all times. <b>DO NOT</b> allow unsupervised children or visitors in the shop at any time.</p>
--	--





# Beginning Assembly

---

---

This section will cover the basic assembly and adjustment instructions needed to begin operation. Complete the assembly in the order provided in this manual and then read the remaining portion of the manual before attempting any type of operation.

**Your safety is important! Please follow the warnings below during this entire section:**

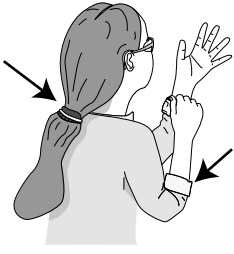
	<p><b>⚠ WARNING</b> Loose hair and clothing could get caught in machinery and cause serious personal injury. Keep loose clothing rolled up and long hair tied up and away from machinery.</p>
---	---

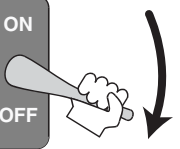
	<p><b>⚠ WARNING</b> Disconnect power to the machine during the entire assembly process. Failure to do this may result in serious personal injury.</p>
---	---

	<p><b>⚠ CAUTION</b> Sharp edges on metal parts may cause personal injury. Examine the edges of all metal parts before handling.</p>
---	---



# Floor Mounting

---

---

**To mount the sander to the floor:**

The sander needs to be mounted in a level location where it can be easily serviced from all sides. Also, consider the largest workpiece you might need to sand before deciding on a final position.

Mount the sander to wooden floors with 1/2" lag bolts and washers. Mount the sander to concrete floors with 1/2" anchor-style bolts designed for concrete applications. Note—*Be sure to carefully follow the anchor bolt manufacturer's instructions.*



# Air Line Hook-Up

---

---

## To hook up the air line:

1. Connect the hose from your air compressor to the air inlet (**Figure 7**) on the regulator.
2. Make sure the red handle on the regulator is in the open position (parallel with the air inlet).
3. Lift the black regulator knob (**Figure 7**) and adjust it until the air pressure gauge reads 75 PSI. Note—*Turn the dial clockwise to increase the air pressure and counterclockwise to lower the air pressure.*
4. Push the regulator knob down until it snaps.

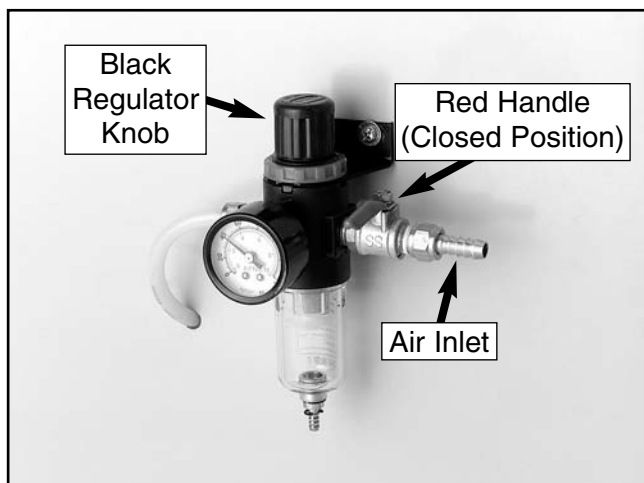

**Figure 7.** Air inlet located on regulator.



# Dust Collection

---

---

An efficient and clean dust collection system is essential to the proper function of the sander. Ensuring a healthy work environment is also dependent upon cleaning and maintaining your dust collection system.

## To hook up the dust collection system:

1. Install the 4" dust port (**Figure 8**) on the mounting locations at the top of the sanding unit with the supplied M6-1.0 x 10 phillips head screws.

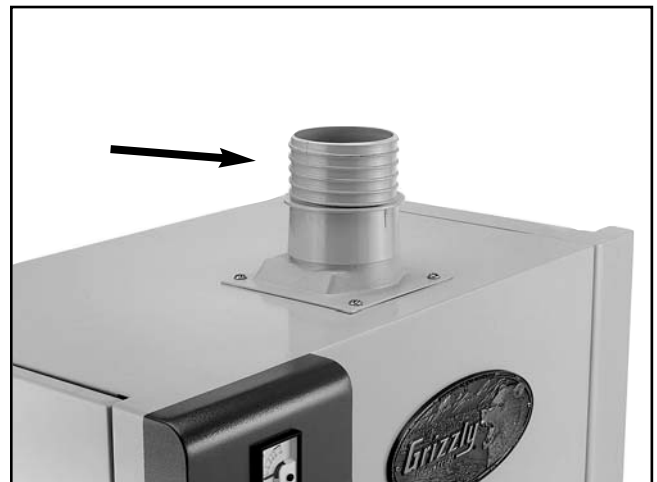

**Figure 8.** Dust collection hook-up.

2. Clamp a hose from your dust collection system to the dust port.



# Sanding Belt

## To install the sanding belt:

1. **Disconnect the sander from the power source!**
2. De-activate the belt tension by using the belt tension switch (**Figure 9**).

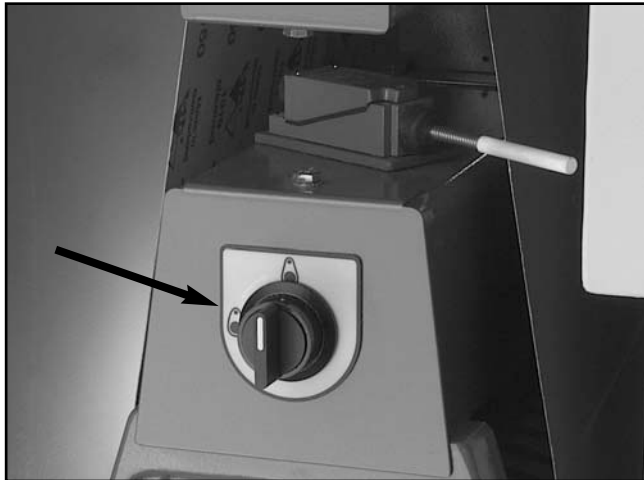

**Figure 9.** Roller tension switch.

3. Remove the lock handle bolt (**Figure 10**) by turning it counter-clockwise  $\frac{1}{2}$  a turn and pulling it up and out of the mounting hole.

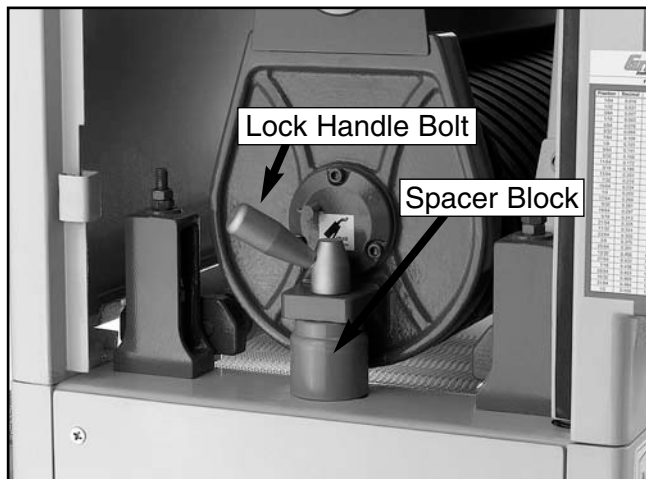

**Figure 10.** Components used when changing a sanding belt.

4. Remove the spacer block (**Figure 10**).
5. Install the sanding belt by starting first on the upper roller and then the lower roller. Note—*The sanding belt must be centered between the limit switches. If either edge of the sanding belt is touching either limit switch, turn the belt tension switch off and adjust the belt until it is properly centered as shown in **Figure 11**.*

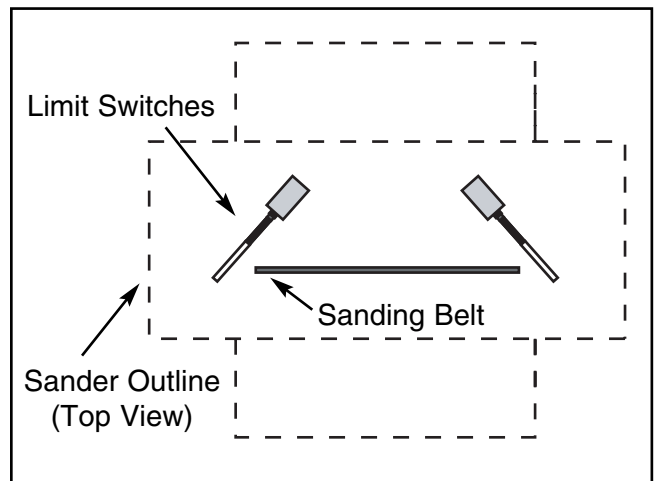

**Figure 11.** Proper position of belt between the limit switches.

## **NOTICE**

**The directional arrow on the back of the sanding belt must be pointing in a counter-clockwise direction when installing it. Failure to install the sanding belt correctly could result in damage to the sanding belt or the sander itself.**

6. Replace the spacer block and tighten down the lock handle bolt.
7. With your hands clear of all moving parts, tension the belt.



# Pressure Rollers

The pressure rollers have been set at the factory, but for safety, you should verify that they are set below the level of the sanding roller.

## **!WARNING**

It is absolutely essential to keep the pressure rollers set below the level of the sanding roller. If the pressure rollers are even, or higher than the sanding roller, the wood could be propelled from the sander at a high rate of speed. This situation could cause serious personal injury.

To check the pressure roller height:

1. **Disconnect the sander from the power source!**
2. Place a piece of scrap wood of uniform thickness across the table so it spans both the front and rear pressure rollers at the same time.
3. With the air pressure connected and the sanding belt installed and tensioned, manually raise the table and verify that the board touches both pressure rollers before it touches the sanding belt. Note—*If the board does not touch both pressure rollers before it touches the sanding belt, then the pressure rollers must be adjusted before operation. See "Pressure Rollers" on page 31 for step-by-step instructions on how to do this.*



## **!WARNING**

Serious personal injury could result if the machine is connected to the power source during assembly or adjustment. Wait until the machine is turned off, unplugged and all working parts have come to a complete stop before you attempt to assemble or adjust the machine!

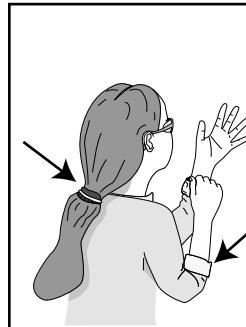

## **!WARNING**

Loose hair and clothing could get caught in machinery causing serious personal injury. Keep loose clothing rolled up and long hair tied up and away from machinery.

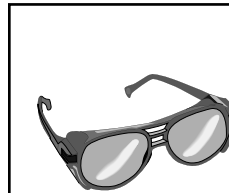

## **!WARNING**

Projectiles thrown from the machine could cause serious eye injury. Wear safety glasses during start up.

**Before starting the machine:**

1. Read this manual and make sure you take all safety precautions before operating this machine.
2. Make sure the machine is connected to an air compressor and the pressure gauge reads 75 PSI.
3. Make sure all tools or foreign objects have been removed from the machine.
4. Review *Section 3: Circuit Requirements* on **page 6** and make sure all the wiring is correct.

## Starting the machine:

1. **Wear safety glasses at all times when running the machine!**
2. Connect the machine to the power source.
3. Press the TABLE UP and TABLE DOWN keys. The table should go up and down smoothly.
4. Press the FEED BELT START and FEED BELT STOP buttons. The feed belt should start, run and stop smoothly.
5. Press the SANDING BELT START and SANDING BELT STOP buttons. The sanding belt should start, run and stop smoothly.

The machine should run smoothly, with little or no vibration or rubbing noises. Strange or unnatural noises should be investigated and corrected before operating the machine further.

If the machine seems to be running correctly, let it run for a short time to ensure that the moving parts are working properly with no excessive vibration. DO NOT operate the machine if problems cannot be corrected.

If you cannot locate the source of unusual noises, feel free to contact our Service Department at (570) 546-9663.



# Recommended Adjustments

---

---

For your convenience, the adjustments listed below have been performed at the factory and require no further adjustment. However, because of the many variables involved with shipping, we recommend that you read through *Section 8: Service Adjustments* on **page 27** and verify that the adjustments are correct.

## Recommended adjustment checklist:

- Calibration
- Feed Belt Tension
- Feed Belt Tracking
- Oscillation Timing
- Oscillation Speed
- Pressure Rollers
- Table Parallelism
- V-Belt Adjustment
- Air System



# SECTION 6: OPERATIONS

## Before Sanding

Your safety is important! Please follow the warnings below during this entire section:

### **WARNING**

To avoid serious personal injury, read and become familiar with the entire instruction manual before using the Model G0527.

### **WARNING**

Damage to your eyes, lungs, and ears could result from failure to wear safety glasses, a dust mask, and hearing protection while sanding with this machine.



### **WARNING**

Loose hair and clothing could get caught in machinery and cause serious personal injury. Keep loose clothing rolled up and long hair tied up and away from machinery.



## Choosing Sandpaper

### **NOTICE**

#100 and #150 grit sanding belts are included with the Model G0527.

The grit you choose will depend on the type of work, the species of wood and the stage of finishing. Below is a chart that groups abrasives into different categories and shows which grits fall into each one. We recommend using aluminum oxide sanding belts for best results.

Grit	Type
60	Coarse
80-100	Medium
120-150	Fine

The general rule of thumb is to sand a workpiece with progressively higher grit numbers, with no one grit increase of more than 50; however, the type of wood and desired finish will determine the best grit to use.



# Table Movement

The table height can be adjusted either manually or by power assist.

**Manual Adjustment**—Manual adjustments are made by turning the handwheel located under the front of the infeed table. The thickness measurement is displayed on the digital readout.

**Power Assist**—Press the TABLE UP or TABLE DOWN key on the control panel shown in **Figure 12**. The digital display reading changes as the table moves up and down.

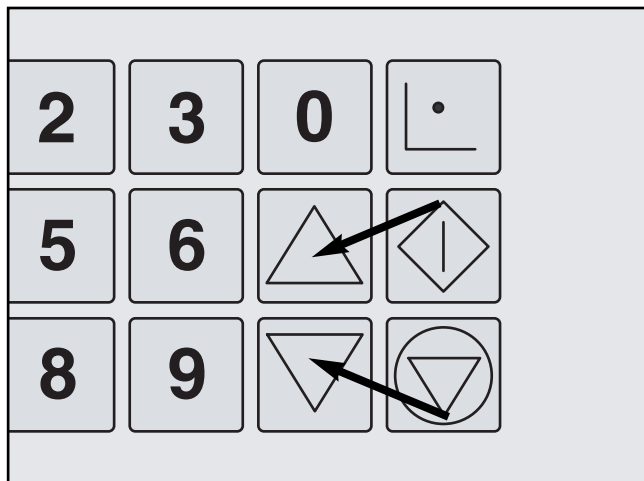

**Figure 12.** Controls for adjusting the table height.

## **NOTICE**

The thickness gauge is pre-calibrated from the factory; however, correct calibration should be verified by using the instructions on page 27.



# Adjusting Feed Rate

The feed belt motor and gear assembly (**Figure 13**) controls the speed of the feed belt. The Model G0527 features feed belt speeds of 16.4, 23, and 32.8 FPM.

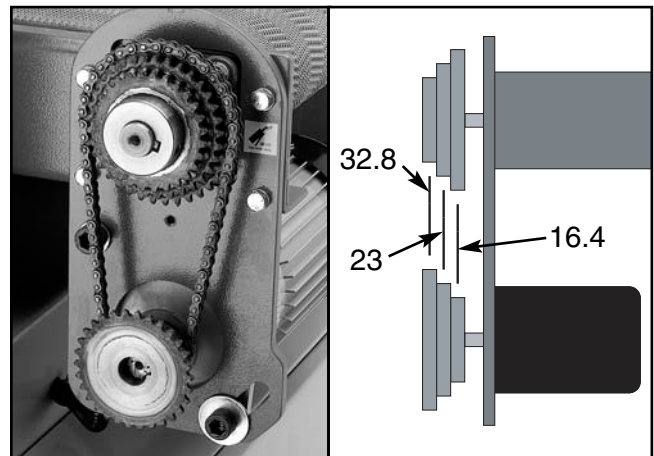

**Figure 13.** Table drive chain and sprockets.

### To change feed belt speed:

1. **Disconnect the sander from the power source!**
2. Remove the cap screw that secures the feed belt motor cover.
3. Loosen the motor mount bolts so that the motor will slide up enough to get the chain off the sprockets.
4. Determine which speed is best for your application and place the chain accordingly.
5. Tighten the motor mount bolts loosened in **step 3**.
6. Replace the motor cover and secure it with the cap screw removed in **step 2**.



# Amperage Meter

The amperage meter is located above the control panel as shown in **Figure 14**. Use the meter to monitor the amperage load on the machine while performing sanding operations.



**Figure 14.** Amperage meter.

## Normal Operating Load

G0527, single-phase, 220V.....35 amps

If the sanding operation draws current in excess of this limit, you run the risk of tripping the circuit breaker and the overload relays in the electrical box.

## **NOTICE**

There are many variables that affect the overall load on the sander. Depth of cut, the species of wood being sanded, the grit size on the sanding belt, and the feed rate, all contribute to the load on the sander. As a general rule, always start with a small load and work your way up. **DO NOT** push your machine to its maximum load; instead, make multiple passes, install a coarser grit paper, or reduce the feed rate.



# Sanding Workpiece

Typically, no more than 0.5mm (approx.  $\frac{1}{64}$ " ) of material is removed during each pass. Attempts to remove too much material can cause jamming, wood burning, rapid paper wear or tearing, poor finish and belt slippage.

**The following is the correct sanding operating procedure:**

1. **Wear safety glasses, a dust mask, and hearing protection!**
2. Turn on the dust collector.
3. On the initial pass, adjust the table to approximately  $\frac{1}{4}$ " greater than the thickness of the workpiece. Note—*This reduces the chance of jamming the sander on undetected high points on the workpiece.*
4. Continue to raise the table  $\frac{1}{16}$ " between each successive pass until the sander begins to sand the workpiece.

## **NOTICE**

It may be necessary to send wide stock through the sander two or three times between table height adjustments. This reduces the likelihood of burning the wood and produces a more consistent finished thickness.







# SECTION 7: MAINTENANCE

## General

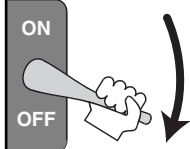
Your safety is important! Please follow the warnings below during this entire section:

	<p><b>⚠ WARNING</b> Disconnect power to the machine when performing maintenance, assembly or adjustments. Failure to do this may result in serious personal injury.</p>
---	---

	<p><b>⚠ WARNING</b> Loose hair and clothing could get caught in machinery causing serious personal injury. Keep loose clothing rolled up and long hair tied up and away from machinery.</p>
--	---

	<p><b>⚠ WARNING</b> Wear safety glasses during the entire maintenance process. Failure to comply may result in serious personal injury.</p>
---	---



## Schedule

The following items should be checked each time the sander is used:

- Loose mounting bolts.
- Damaged sanding belt.
- Worn or damaged wires.
- Air line water collection cup is filled with water.
- Any other condition that could hamper the safe operation of this machine.

### Weekly:

- Grease the eight fittings located on the feed belt roller axles and the sanding belt roller axles. They are identified with yellow stickers.

### Monthly:

- Apply a generous amount of grease to the table elevation screws. Be sure to cover the adjustment screws with the dust covers when finished.
- Remove the lower side panel to access the table lifting mechanism. Apply a generous amount of grease to the chain and gears associated with the table lifting mechanism. Be careful to not get grease on any of the V-belts. This could cause them to slip off their pulleys.
- Apply a generous amount of multi-purposed grease to the table drive chain and sprocket assembly.



# Servicing Brakes

---

---

Eventually the brake pads will wear out. Checking and replacing these is a simple project that can be done in the shop, with the exception of having the rotor resurfaced.

## To check the brake pads:

1. **Disconnect the sander from the power source and remove air pressure completely!**
2. Remove the four screws that secure the motor cover on the right-hand side of the machine. Note—The brake caliper is located underneath the rotor, which is attached to the motor arbor.
3. The brake pads consist of a metal plate with a composite pad. With a fine ruler, measure the thickness of the composite pad only. If one of the pads is below  $\frac{1}{8}$ " (approx. 3mm), replace both.

## To perform a pad replacement:

1. **Disconnect the sander from the power source and remove air pressure completely!**
2. Remove the nuts from the two mounting bolts. There are two snap rings on the mounting pins behind the bracket. Remove these.

3. Pull the mounting pins out of the caliper bracket and remove the air line from the caliper. The caliper should now be able to be removed as in **Figure 15**.
4. The brake pads are secured to the caliper with cap screws. One of these screws is easily accessible; the other can only be reached by disassembling the brake caliper. Do this and remove the cap screws to remove the brake pads.

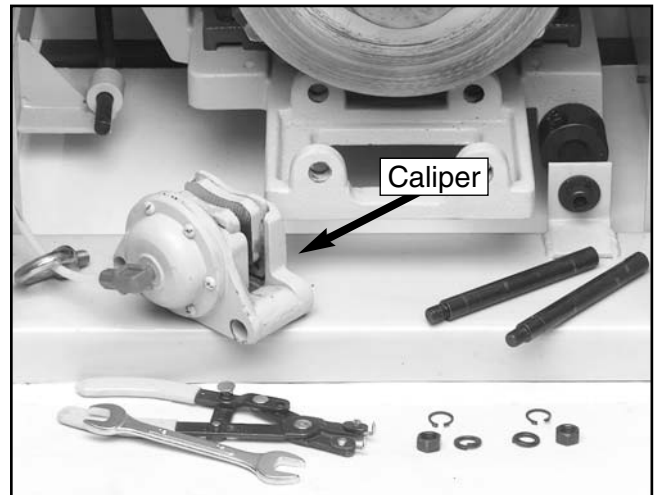

**Figure 15.** Disc brake components.

5. Remove the brake rotor and have it professionally resurfaced. For this, find a local machinist or auto supply store that regularly resurfaces brake rotors for automobiles. If visible cracks are present in the brake rotor, replace it with a new one. Remove oil and dirt from the rotor with automotive brake cleaner. Once clean, only handle the rotor with a dry rag and install exactly the reverse of removal.
6. Install new brake pads, mount the caliper and reconnect the air line.



# Air Circuit Filters

---

---

The air filter on the Model G0527 is located on the main regulator (**Figure 16**). Empty the filter trap as it becomes filled with moisture and dirt. The internal white filter should be replaced yearly.

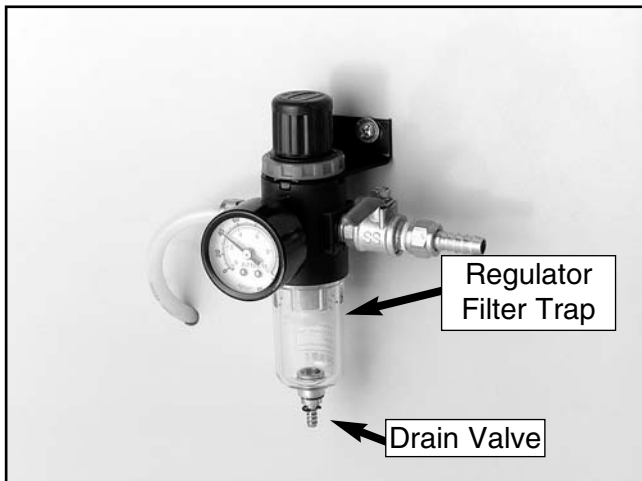

**Figure 16.** Regulator filter trap. Push lower drain valve to empty it.



# Clean Sanding Belts

---

---

You can greatly increase the lifespan of your sanding belts if you clean them often. As mentioned on **page 35**, cleaning pads are the fastest way to clean wood dust from the sanding belts.





# SECTION 8: SERVICE ADJUSTMENTS

---

---

## Calibration

---

---

### ***NOTICE***

The digital thickness gauge has been calibrated at the factory and should require no further adjustment, however, we recommend verifying its accuracy.

The first board fed through the sander will be used to test the accuracy of the digital thickness gauge.

**To calibrate the digital thickness scale:**

1. Follow the start up procedures from **Section 5: Set Up** beginning on page 12.
2. Using a properly set-up planer, plane a board to uniform thickness.
3. Lower the sander table far enough to place the planed board under the sander roller.
4. Manually raise the table until the board just touches the sanding roller.
5. Remove the board without changing the table height. This ensures the table will be properly adjusted for the first sanding pass.
6. Run the board through the sander several times at the initial height setting. Manually raise the table 0.020" and pass the board through the sander several more times. Monitor the amperage meter and the resulting load on the sander.

7. Using a precise micrometer or set of calipers, measure the thickness at various points around the board.
8. Continue sanding the board until the average thickness measurement is within  $\pm 0.003$ ". Note—*The final several passes should be done without adjusting the table height. This ensures the most consistent average thickness.*
9. Make note of the digital display read-out. It should be the same as the average thickness of the sanded wood.
  - If they are the same, the sander is properly calibrated and accurate to the nearest 0.001". Continue to the next sub-section.
  - If the digital display readout is not the same, recalibration is needed. Continue on to **step 10**.
10. Without moving the table height, enter the numerical measurement of the average thickness of the sanded wood into the digital key pad on the control panel. Note—*The average thickness of the sanded wood should now be flashing on the digital read-out.*
11. Press and hold the SET key until the display stops flashing. The sander is now correctly calibrated.



# Feed Belt Tension

To adjust the feed belt tension:

1. **Disconnect the sander from the power source!**
2. Raise the safety guard (**Figure 17**) on the front end of the feed table.
3. Increase or decrease the feed belt tension by adjusting the bolts located on the left and right side of the front table roller (**Figure 17**).  
Note—*When tensioned properly, you should not be able to lift the feed belt off the table surface or slide it back and forth.*

**!WARNING**  
DO NOT sand boards with the guard removed. Failure to follow this warning could result in serious personal injury.

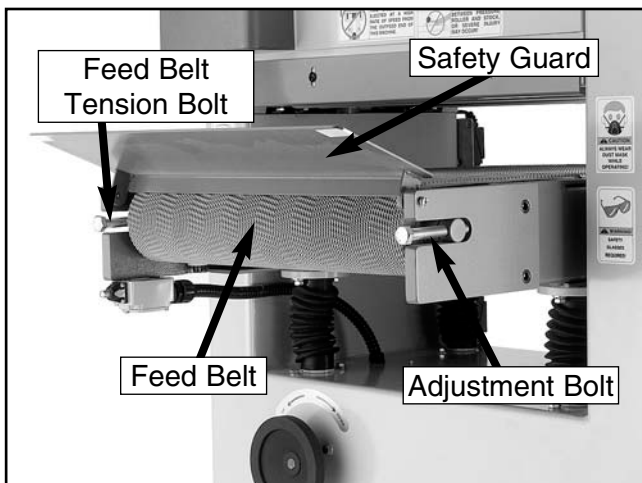

**Figure 17.** Feed belt tension adjustment controls.



# Feed Belt Tracking

## **NOTICE**

Adjust the feed belt tension before adjusting the feed belt tracking.

To adjust the feed belt tracking:

1. Start the feed belt.
  - If the feed belt is tracking to the **right** side of the table, turn the **right** adjustment bolt (**Figure 22**) clockwise.
  - If the feed belt is tracking to the **left** side of the table, turn the **left** adjustment bolt (**Figure 18**) clockwise.

Note—*The edge of the feed belt should just touch the guide wheels as shown in **Figure 18**.*

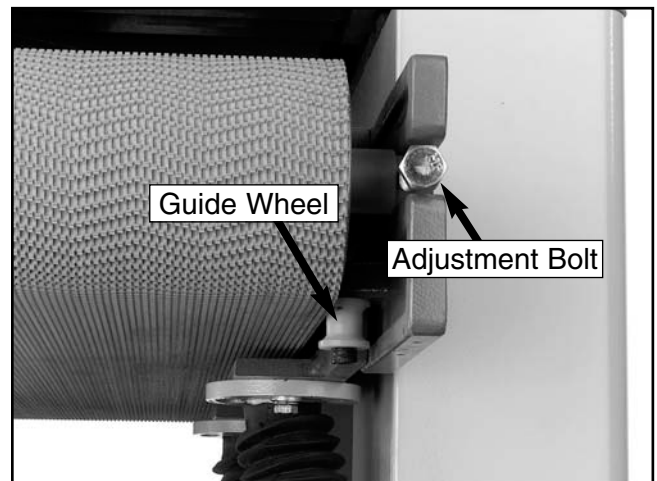

**Figure 18.** Feed belt tracking components.

2. Run the feed belt for 3-5 minutes and verify the tracking.



# Belt Oscillation

## **NOTICE**

The oscillation adjustments have been performed at the factory and should require no further attention. However, we recommend verifying the settings.

When the oscillation is correctly adjusted, the sanding belt oscillates to the left and to the right at the same speed and without coming into contact with the limit switches. If the sanding belt oscillates too far to the left or right, making contact with the limit switches as shown in **Figure 19**, the emergency braking system will activate.

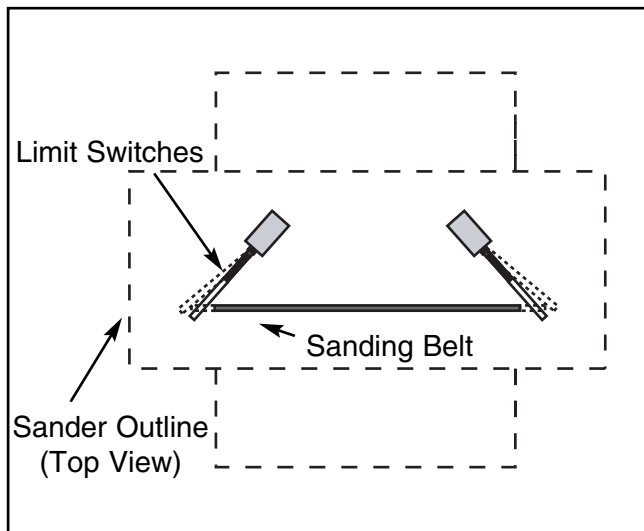

**Figure 19.** Improper oscillation.

### To check the sanding belt oscillation:

1. Be sure the sanding belt is properly installed and the belt tension switch is set to tension the belt.
2. With safety glasses on and the left access door still open, press the SANDING BELT START Button.

3. Watch as the belt either oscillates back and forth continuously, or tracks into one of the two limit switches, triggering the emergency brake.

— If the belt tracks into either limit switch, adjust the two air flow adjustment knobs independently of one another until the belt no longer hits the limit switches. Trial and error may be necessary.

— If the oscillation time is not consistent from one direction to the other, the air cylinder arm needs to be lengthened or shortened according to the following guidelines:

- If the belt tracks away from the air cylinder faster, shorten the arm.
- If the belts tracks towards the air cylinder faster, lengthen the arm. Note—A small adjustment goes a long way. Make many smaller adjustments rather than one or two large adjustments.

— If the oscillation rate needs to be increased or decreased, adjust the air flow adjustment counter-clockwise in small, equal amounts until the desired speed is achieved. Note—A combination of knob adjustments and air cylinder arm length adjustments may be needed to achieve the ideal oscillation timing and speed. Trial and error adjustments may be necessary.



# Table Parallelism

## NOTICE

The table has been adjusted at the factory and should require no further attention. However, we recommend verifying that it is parallel with the sanding roller.

Adjusting the table parallelism can be a very tedious task that takes a great amount of patience. DO NOT adjust the table unless you are having trouble sanding your workpiece to a uniform thickness. Take precise notes on **any** adjustments you make to **any** of the table elevation screws (**Figure 20**). This will allow the original setting to be re-established.

### To adjust the table parallelism:

1. Pass a 24" wide board through the sander until the **entire** surface of the board is making contact with the sanding belt.
2. Measure the thickness of the board at various points around the edge.  
  
— If there is a variation of thickness, the table can be adjusted accordingly.
3. **Disconnect the sander from the power source!**
4. The corners of the table can be independently adjusted up or down by spinning the table elevation screws (**Figure 20**) located under each corner of the table. Note—*The table mounting bolts (**Figure 29**) need to be removed first.*

## NOTICE

When adjusting the left front elevation screw, make the same adjustment to the left rear elevation screw. This ensures the height from the front to the back of the table remains unchanged. Do the same when adjusting the right elevation screws.

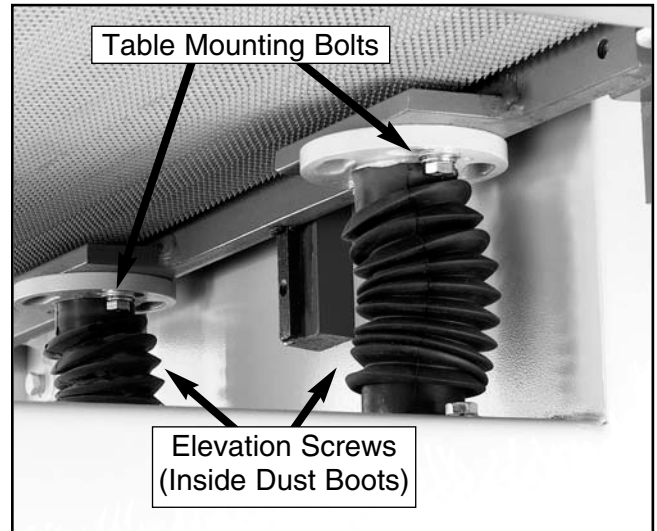

**Figure 20.** View of table underside.

5. To raise the elevation screws, turn them counterclockwise. To lower them, turn them clockwise. One quarter of a turn raises or lowers the elevation screws approximately 0.020".
6. Retighten the table mounting bolts loosened in **step 4**.
7. Connect the sander to the power source.
8. Repeat **Steps 1-7** until the board is sanded to a uniform thickness.





# Pressure Rollers

Note—Variables such as feed rate, depth of the cut, and the type of sanding belt can play a big part in determining the proper amount of downward pressure exerted by the rollers. Some experimentation may be necessary to achieve the desired results. However, under no circumstances should the pressure rollers be set even with, or higher than, the sanding roller.

## To adjust the pressure rollers:

1. **Disconnect the sander from the power source!**
2. Plane (2) 36" long 2x4's to a uniform thicknesses. Place one board along the length of the feed belt on the right-hand side and place the other board on the left-hand side.
3. With the sanding belt tensioned (**Figure 21**), grab the edge of the sanding belt and move it up and down about an inch or so. At the same time, manually raise the table until you just hear the sandpaper make contact with the surface of the wood. **DO NOT** continue to raise the table beyond that point.

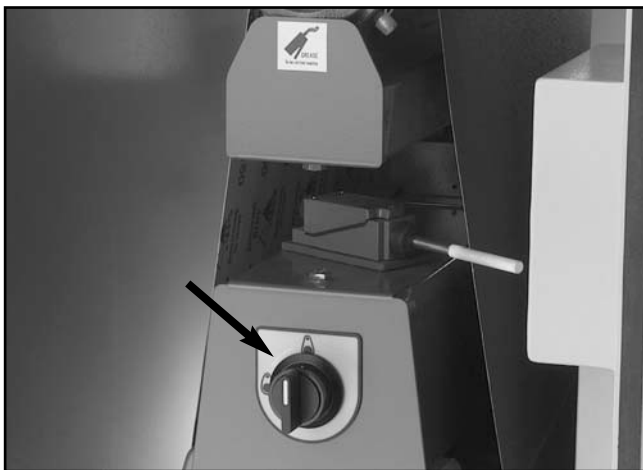

**Figure 21.** Roller tension switch.

4. Connect the sander to the power source and make note of the reading on the digital display. Then manually lower the table 0.020" to 0.030". This is how much lower the infeed pressure roller should be set when compared to the sanding surface of the sanding roller.

5. **Disconnect the sander from the power source!**
6. Loosen the roller lock nuts (**Figure 22**) on the infeed pressure roller. Turn the adjustment bolts (**Figure 22**) to lower the pressure roller until it just touches the board. Note—**DO NOT** continue to lower the roller beyond that point.

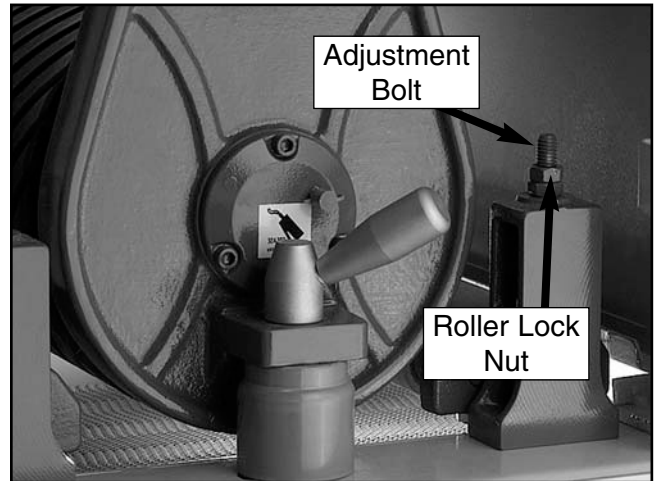

**Figure 22.** Pressure roller parts.

7. Tighten the roller lock nuts and recheck your settings.
8. Connect the sander to the power source and make note of the reading on the digital display. Then manually lower the table an additional 0.020" to 0.030". This is how much lower the outfeed pressure roller should be set when compared to the height of the infeed roller.
9. Loosen the roller lock nuts on the outfeed pressure roller. Turn the adjustment bolts to lower the pressure roller until it just touches the board. Note—**DO NOT** continue to lower the roller beyond that point.
10. Tighten the roller lock nuts and recheck your settings.



# V-Belt Adjustment

## **NOTICE**

The V-belts have been properly adjusted at the factory and should require no further attention. If future adjustment is needed follow the instructions below.

There are two V-belts on the Model G0527—one on the table lifting motor (Figure 23) and one on the sanding drum motor (Figure 24).

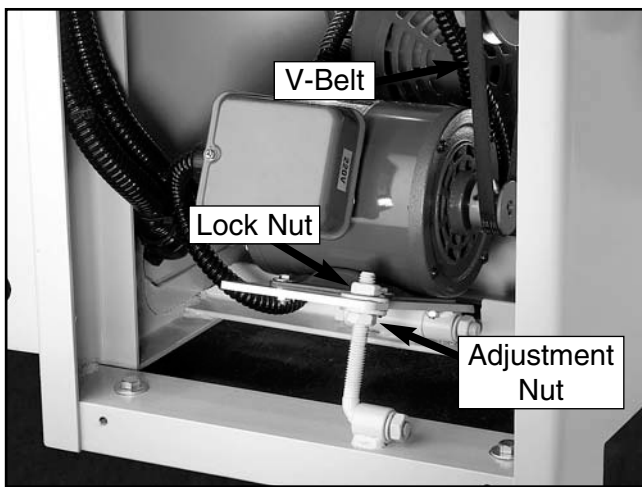

Figure 23. Table lifting motor V-belt.

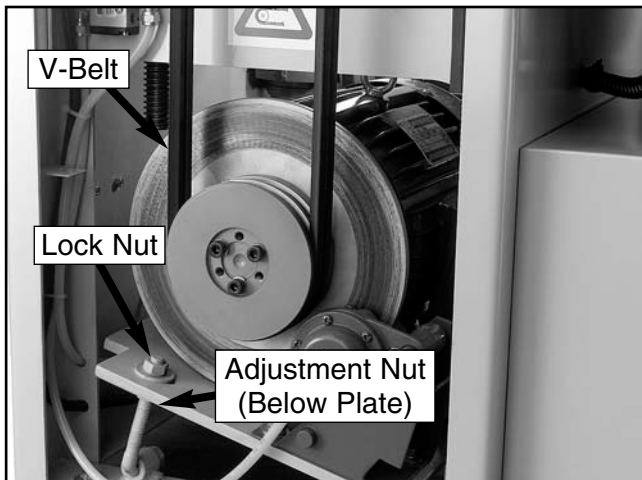

Figure 24. Sanding drum motor V-belt.

To adjust either V-belt:

1. Disconnect the sander from the power source!
2. Loosen the lock nut (Figure 23 & 24).
3. Turn the adjustment nut up or down until the proper V-belt tension is achieved. Note—*The V-belt should deflect 1" off of center when pushed with your finger.*
4. Retighten the lock nut.



## Air System

The air system is durable and reliable; however, components do wear with age. If you suspect that an item in your air system may be having problems, see the air line circuit on the next page.

Periodically inspect the following:

- Carefully inspect all air lines for leaks. Replace faulty hoses.
- Check the air connections for leaks. A small amount of soapy water in a questionable area will bubble if there is a leak.
- Make sure the lines are not clogged. Remove questionable lines and blow through them as a test.

## **CAUTION**

If you ever determine that a component in the air system is malfunctioning, **DO NOT** operate the sander. Fix the problem before resuming operation.



# Air Line Circuit

- A. Compressor
- B. Pressure Regulator
- C. Solenoid
- D. Disc Brake
- E. Air Cylinder for Sanding Belt Oscillation
- F. Air Flow Adjustment Knobs
- G. Air Cylinder for Sanding Belt Tension
- H. Roller Tension Switch

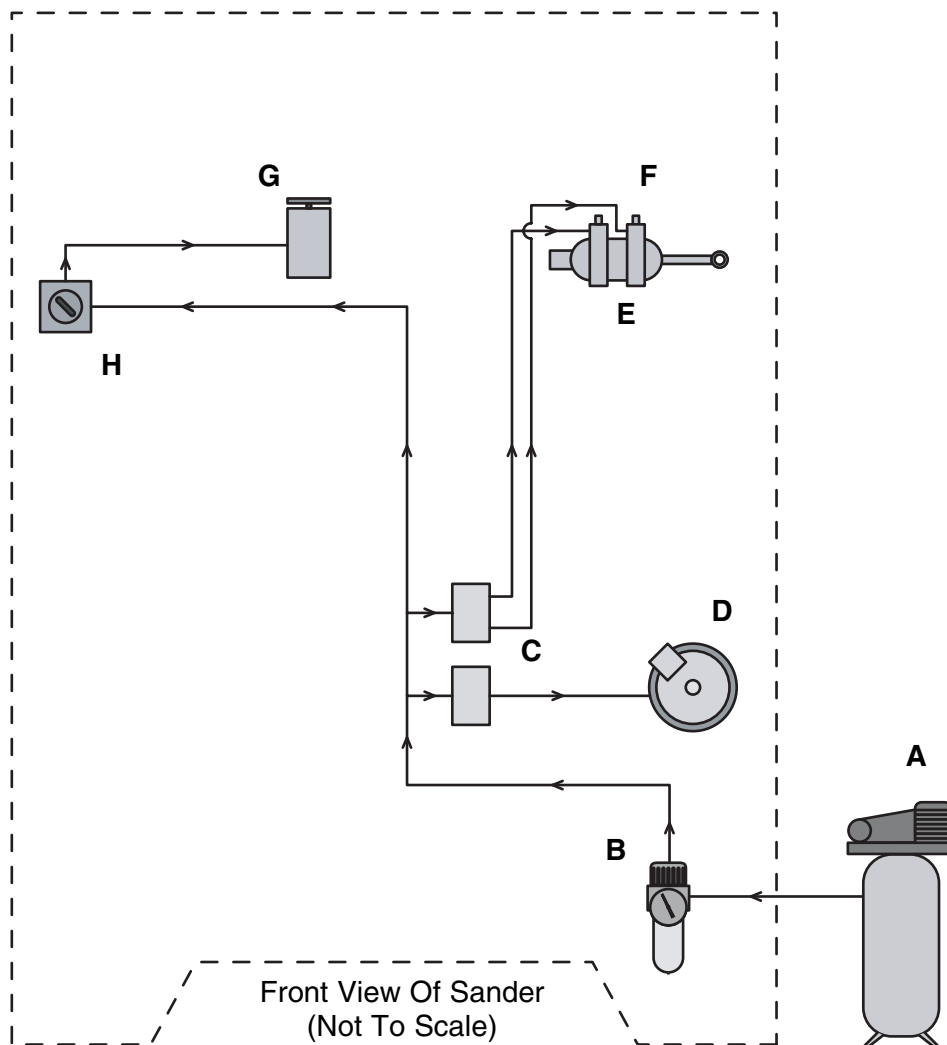



# SECTION 9: REFERENCE INFO

---

---

## General

---

---

This section contains the following subsections for the Model G0527: aftermarket accessories, data sheets, wiring diagrams, parts diagrams and list, troubleshooting, and warranty/return information.

If you need parts or help in assembling your machine, or if you need operational information, call the service department at (570) 546-9663. Trained service technicians will be glad to help you.

If you have any comments regarding this manual, please write to Grizzly at the address below:

Grizzly Industrial, Inc.  
c/o Technical Documentation  
P.O. Box 2069  
Bellingham, WA 98227-2069

We recommend you keep a copy of our current catalog for complete information regarding Grizzly's warranty and return policy. If you need additional technical information relating to this machine, or if you need general assistance or replacement parts, please contact the Service Department at the location listed below.

Grizzly Industrial, Inc.  
1203 Lycoming Mall Circle  
Muncy, PA 17756  
Phone: (570) 546-9663  
Fax: (800) 438-5901  
E-Mail: [techsupport@grizzly.com](mailto:techsupport@grizzly.com)  
Web Site: <http://www.grizzly.com>



## Aftermarket Accessories

---

---

### Cleaning Pads

Cleaning pads (**Figure 25**) are the perfect accessory for wide-belt sanders. Simply set the conveyor table to height and feed the pad through to "unload" a dirty sanding belt. Regular cleaning greatly increases the lifespan of sanding belts. Check with the current Grizzly catalog or [www.grizzly.com](http://www.grizzly.com) for more details.

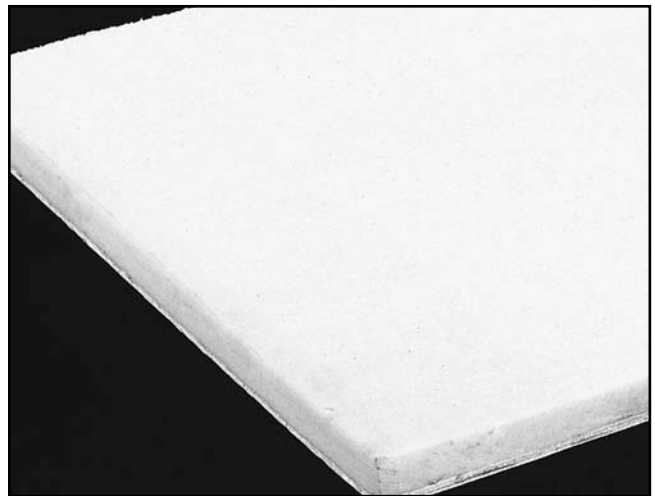

**Figure 25.** Sanding belt cleaning pad.





# MACHINE DATA SHEET

Customer Service #: (570) 546-9663 • To Order Call: (800) 523-4777 • Fax #: (800) 438-5901

## MODEL G0527 18" WIDE-BELT SANDER

Design Type .....Floor Model

### Overall Dimensions:

Width .....30"  
 Height .....57"  
 Depth .....37"  
 Belt Height.....26<sup>3</sup>/<sub>4</sub>"-32<sup>3</sup>/<sub>4</sub>"  
 Weight (Shipping).....1012 lbs.  
 Net Weight .....890 lbs.  
 Approximate Crate Size .....32<sup>1</sup>/<sub>4</sub>" L x 39<sup>3</sup>/<sub>4</sub>" W x 64" H  
 Footprint .....29" x 16<sup>3</sup>/<sub>4</sub>"

### Capacities:

Maximum Board Width .....17<sup>1</sup>/<sub>2</sub>"  
 Maximum Board Thickness .....6"  
 Minimum Board Length .....9"  
 Minimum Board Thickness .....1/8"  
 Surface Speed of Drums .....3550 FPM  
 Conveyor Speed .....16.4, 23, 32.8 FPM  
 Dust Port .....4"  
 Sanding Belt Size .....18<sup>1</sup>/<sub>2</sub>" x 48"  
 Sanding Drum Size.....7<sup>3</sup>/<sub>4</sub>"  
 Air Pressure .....57 PSI

### Sanding Drum Motor:

Type .....TEFC Capacitor Start Induction  
 Horsepower.....5 HP  
 Voltage / Phase / Cycle .....220V / Single-Phase / 60 HZ  
 Amps .....30 A  
 RPM.....1725 RPM  
 Power Transfer to Drums .....Belt

### Conveyor Feed Motor:

Type .....TEFC Capacitor Start Induction  
 Horsepower .....1/2 HP  
 Voltage / Phase / Cycle .....220V / Single-Phase / 60 HZ  
 Amps .....3.8  
 RPM .....1725  
 Power Transfer .....Chain

### Elevation Motor:

Type .....TEFC Capacitor Start Induction  
 Horsepower .....1/3 HP  
 Voltage / Phase / Cycle .....220V / Single-Phase / 60 HZ  
 Amps .....3 A  
 RPM .....1725  
 Power Transfer .....Belt

### General Construction:

Cabinet .....Steel  
 Sanding Belt Oscillation .....1/2"-5/8" Adjustable  
 Sanding Belt Brake .....Disc  
 Control Panel .....Push Button for each motor, plus load sensor

*Specifications, while deemed accurate, are not guaranteed.*

# Parts Diagrams & Lists

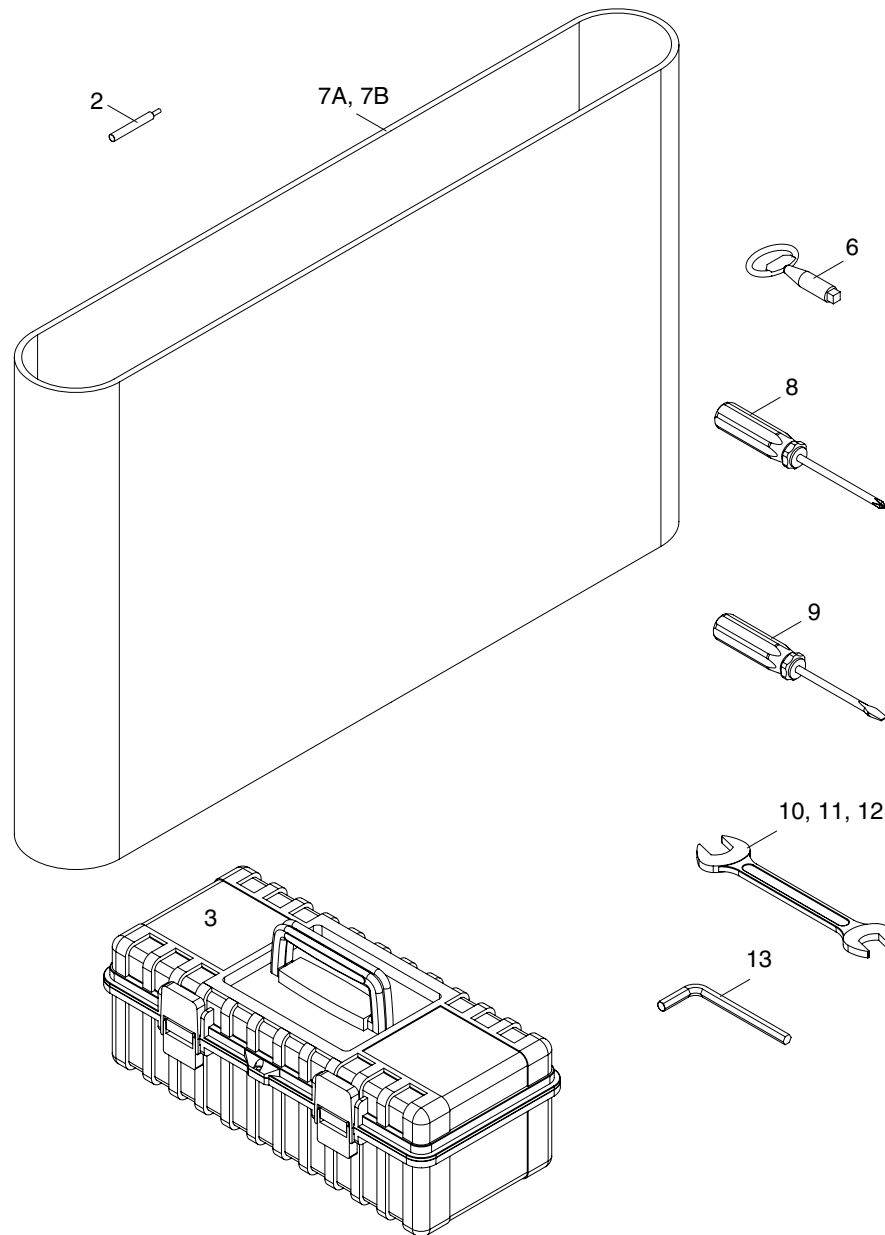

REF	PART #	DESCRIPTION
2	P05270002	LIMIT SWITCH TUBE
3	P05270003	TOOL BOX
6	P05270006	DOOR HANDLE
7	P05270007A	SANDING BELT (#100 GRIT)
7	P05270007B	SANDING BELT (#150 GRIT)
8	P99620008	PHILLIP'S SCREWDRIVER
9	P99620009	FLAT SCREWDRIVER
10	PWR810	8 x 10 WRENCH
11	PWR1214	12 x 14 WRENCH
12	PWR1719	17 x 19 WRENCH
13	P05270013	HEX WRENCH SET

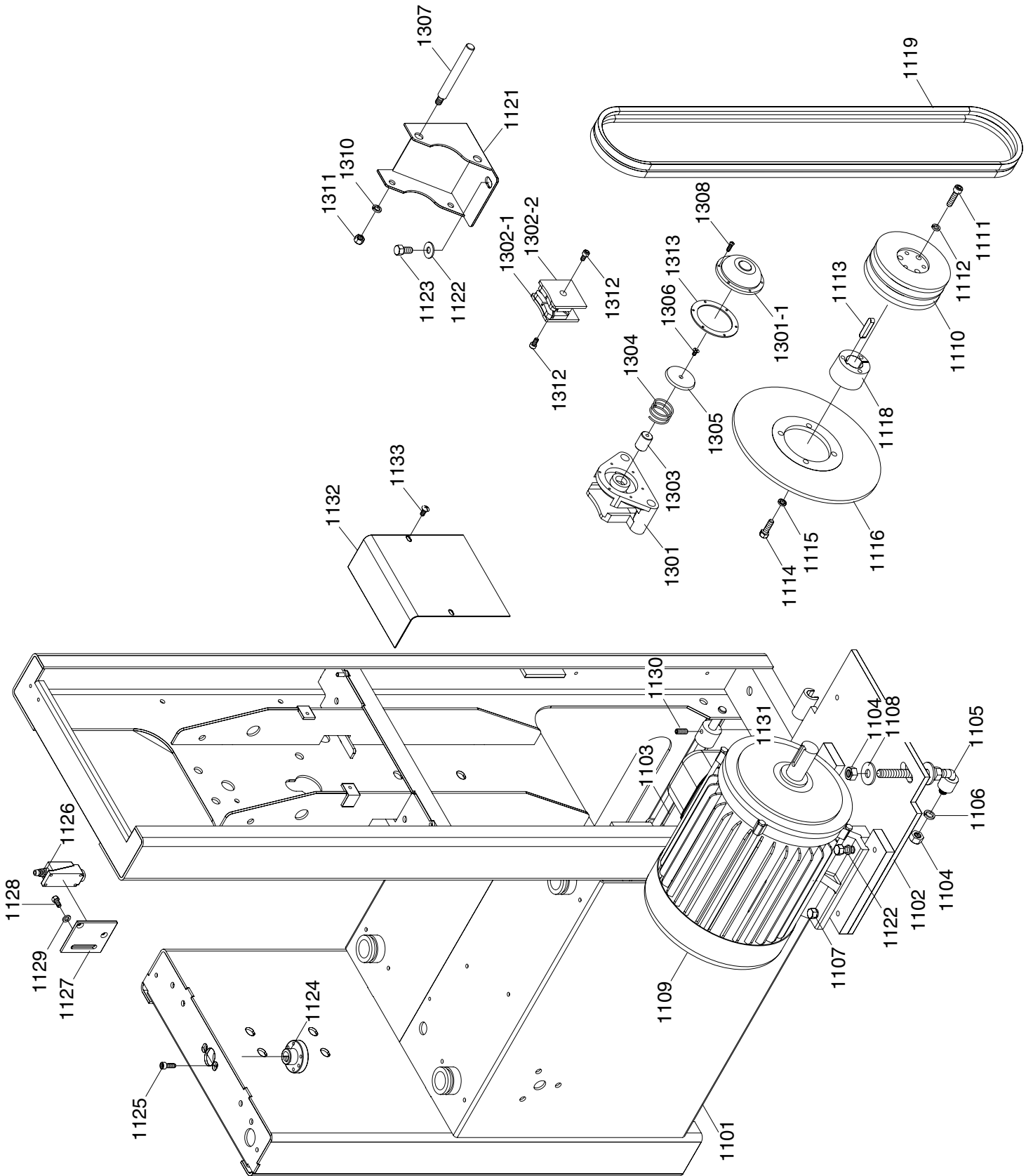



REF	PART #	DESCRIPTION
1101	P05271101	MACHINE FRAME
1102	P05271102	MOTOR BASE
1103	P05271103	MOTOR BASE HINGE
1104	PN06	HEX NUT 1/2-12
1105	P05271105	ADJUSTMENT ROD
1106	PLW07	LOCK WASHER 1/2
1107	PB24	HEX BOLT 3/8-16 X 1 1/4"
1108	PW01	FLAT WASHER 1/2"
1109	P05271109	MOTOR 5 HP
1109-1	P05271109-1	FAN COVER
1109-2	P05071109-2	FAN
1109-3	PC600A	CAPACITOR 600MFD 250V
1109-4	PC030A	CAPACITOR 30UF 300W VAC
1109-5	P05271109-5	CAPACITOR COVER
1109-6	P05271109-6	WIRING COVER
1110	P05271110	PULLEY
1111	PSB11	CAP SCREW 5/16-18 X 1 1/4"
1112	PLW01	LOCK WASHER 5/16"
1113	P05271113	SLIDE
1114	PB03	HEX BOLT 5/16-18 X 1"
1115	PLW01	LOCK WASHER 5/16"
1116	P05271116	DISC BRAKE
1118	P05271118	PULLEY BUSHING
1119	PVA68	V-BELT A-68
1121	P05271121	BRAKE BRACKET

REF	PART #	DESCRIPTION
1122	PW02	FLAT WASHER 3/8"
1123	PB21	HEX BOLT 3/8-16 X 3/4"
1124	P05271124	ELEVATION SCREW RING
1125	PSB05	CAP SCREW 1/4-20 X 3/4"
1126	P05271126	LIMIT SWITCH
1127	P05271127	LIMIT SWITCH PLATE
1128	PB19	HEX BOLT 1/4-20 X 1/2"
1129	PW06	FLAT WASHER 1/4"
1130	PSS18	SETSCREW 5/16-18 X 3/4"
1131	P05271131	MOTOR BASE
1132	P05271132	COVER OF PULLEY
1133	PS04	PHLP HD SCR 1/4-20 X 1/2"
1301	P05271301	BRAKE BRACKET
1301-1	P05271301-1	BRACKET FRONT GUARD
1302-1	P05271302-1	BRAKE LINING
1302-2	P05271302-2	BRAKE LINING
1303	P05271303	BRAKE ARBOR
1304	P05271304	BRAKE LOCK
1305	P05271305	BRAKE INSIDE PIECE
1306	PFH12M	FLAT HD SCR M6-1 X 25
1307	P05271307	BRAKE PIN
1308	PSB10M	CAP SCREW M5-.8 X 15
1310	PLW04	LOCK WASHER 3/8"
1311	PN08	HEX NUT 3/8-16
1312	PSB26M	CAP SCREW M6-1 x 12
1313	P05271313	BRAKE GASKET

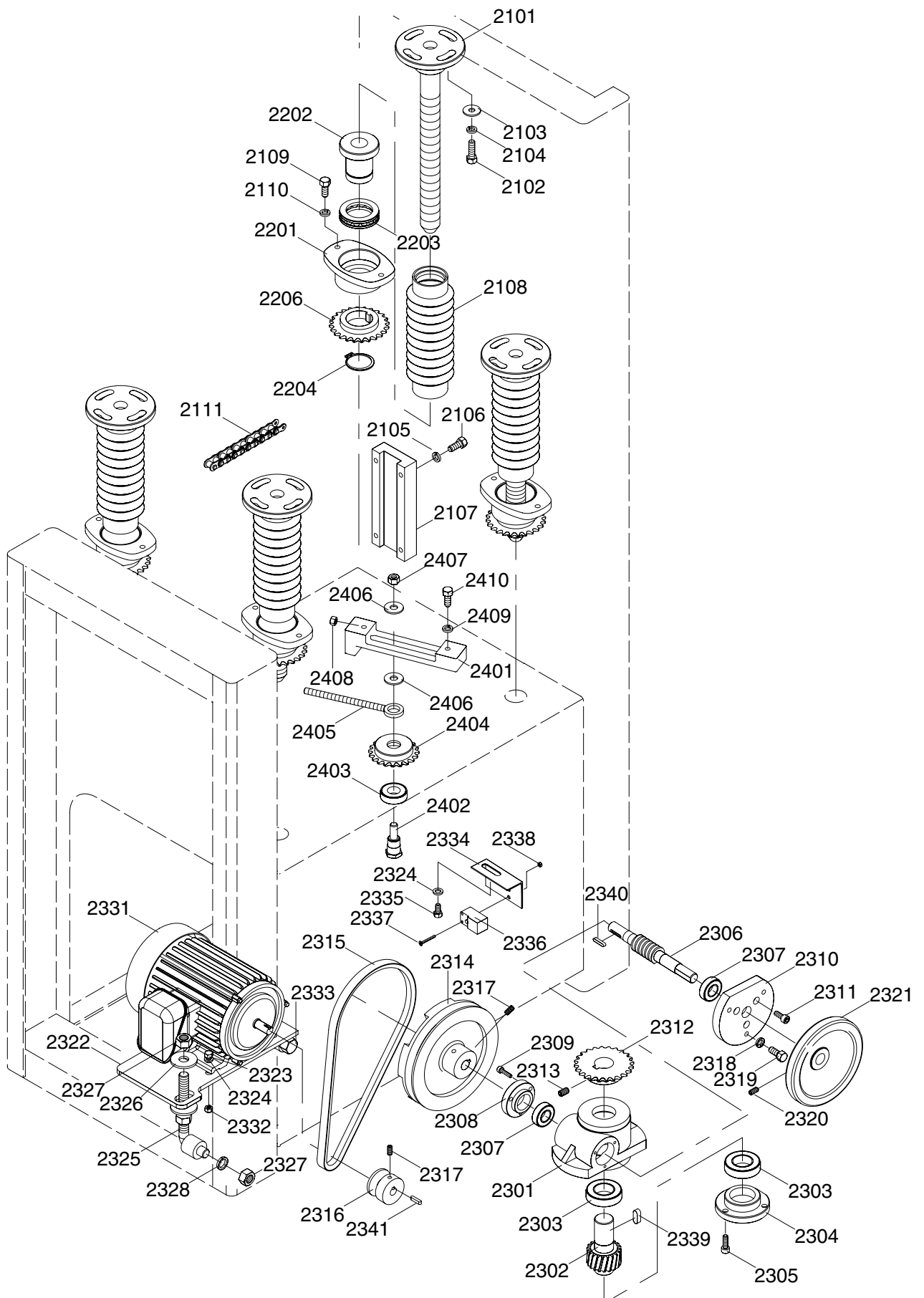

REF	PART #	DESCRIPTION
2101	P052762101	ELEVATION SCREW
2102	PB03	HEX BOLT 5/16-18 x 1"
2103	PW07	FLAT WASHER 5/16"
2104	PLW01	LOCK WASHER 5/16"
2105	PLW04	LOCK WASHER 3/8"
2106	PB21	HEX BOLT 3/8-16 x 3/4"
2107	P052762107	ELEVATION SLIDE
2108	P052762108	DUST GUARD BELLOW
2109	PB07	HEX BOLT 5/16-18 x 3/4"
2110	PLW01	LOCK WASHER 5/16"
2111	P052762111	CHAIN
2201	P052762201	NUT HOUSUNG
2202	P052762202	NUT
2203	P51107	THRUST BEARING 51107
2204	PEC11M	E-CLIP 35MM
2206	P052762206	SPROCKET WHEEL
2301	P052762301	ELEVATION GEAR BOX
2302	P052762302	WORM GEAR
2303	P6005	BEARING 6005Z
2304	P052762304	BEARING CAP
2305	PSB05	CAP SCREW 1/4-20 x 3/4"
2306	P052762306	WORM SHAFT
2307	P6002	BEARING 6002Z
2308	P052762308	BEARING CAP
2309	PSB31	CAP SCREW 10-24 x 5/8"
2310	P052762310	BEARING CAP
2311	PSB01	CAP SCREW 1/4-20 x 5/8"
2312	P052762312	SPROCKET WHEEL
2313	PSS08	SETSCREW 5/16-18 x 1/2"
2314	P052762314	PULLEY
2315	PVA28	V-BELT A-28 4L280
2316	P052762316	PULLEY
2317	PSS07	SETSCREW 1/4-20 x 1/2"
2318	PLW01	LOCK WASHER 5/16"
2319	PB32	HEX BOLT 5/16-18 x 5/8"
2320	PSS07	SETSCREW 1/4-20 x 1/2"

REF	PART #	DESCRIPTION
2321	P052762321	HAND WHEEL
2322	P052762322	MOTOR BASE
2323	PB31	HEX BOLT 1/4-20 x 1"
2324	PLW02	LOCK WASHER 1/4"
2325	P052762325	ADJUSTMENT ROD
2326	PW01	FLAT WASHER 1/2"
2327	PN06	HEX NUT 1/2-12
2328	PLW07	LOCK WASHER 1/2"
2331	P052762331	MOTOR 1/3 HP
2331-1	P05272331-1	FAN COVER
2331-2	P05072331-2	FAN
2331-3	PC100A	CAPACITOR 100 MFD 250V
2331-4	P05272331-4	CAPACITOR COVER
2331-5	P05272331-5	WIRING COVER
2332	PN05	HEX NUT 1/4-20
2333	PB89	HEX BOLT 1/2-12 x 4 1/2"
2334	P052762334	SWITCH FIXING PLATE
2335	PB19	HEX BOLT 1/4-20 x 1/2"
2336	P052762336	PROXIMITY SWITCH
2337	PS55M	PHLP HD SCR M3-.5 x 35
2338	PN07M	HEX NUT M3-.5
2339	PK14	KEY 5/16 x 5/16 x 3/4"
2340	PK48M	KEY 4 x 4 x 20MM
2341	PK38M	KEY 4 x 4 x 23MM
2401	P052762401	ADJUSTMENT PIECE
2402	P052762402	SPROCKET WHEEL SHAFT
2403	P6003	BALL BEARING 6003ZZ
2404	P052762404	SPROCKET WHEEL
2405	P052762405	WHEEL ADJUSTMENT ROD
2406	PW02	FLAT WASHER 3/8"
2407	PN08	HEX NUT 3/8-16
2408	PN02	HEX NUT 5/16-18
2409	PLW01	LOCK WASHER 5/16"
2410	PB07	HEX BOLT 5/16-18 x 3/4"

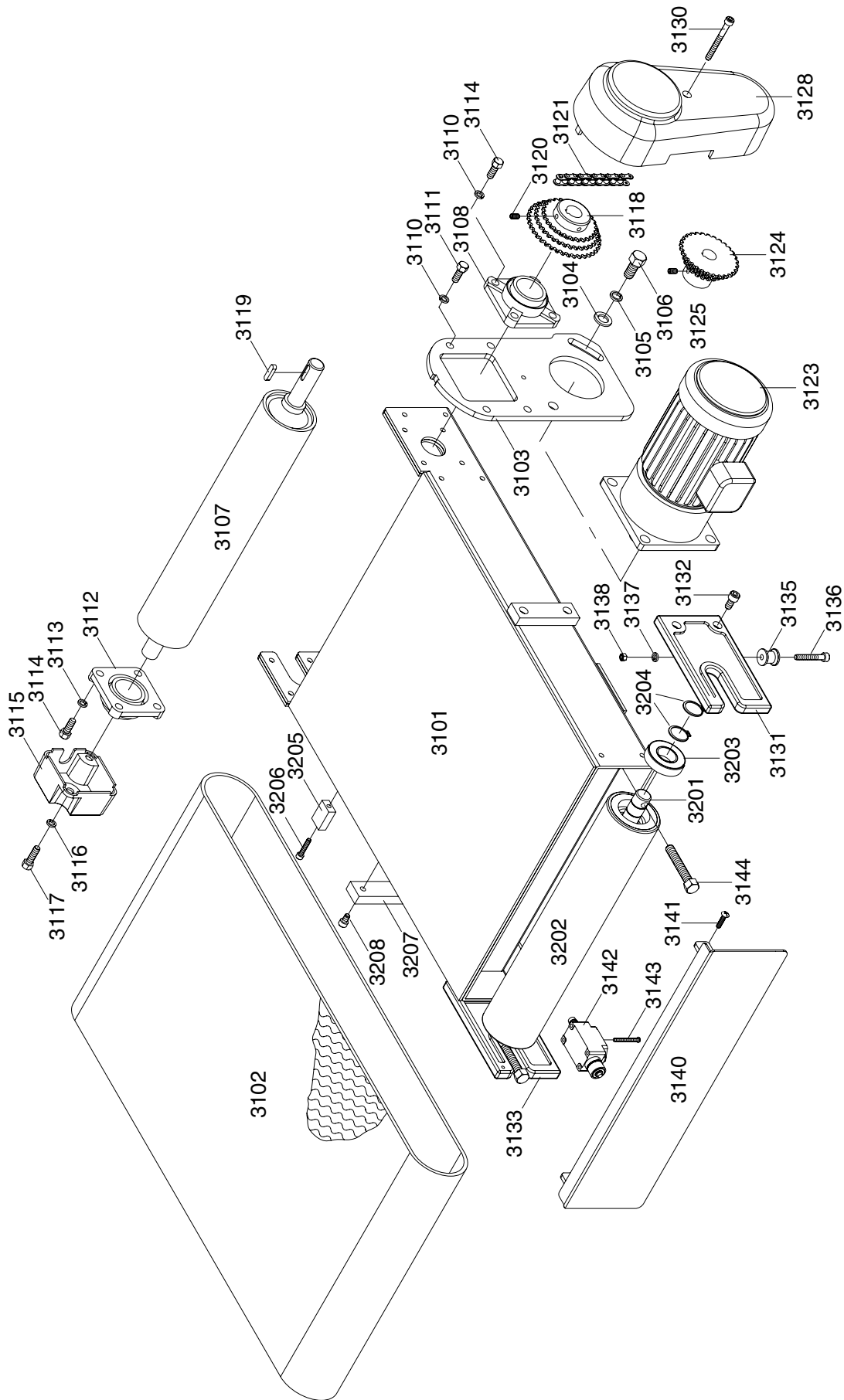

REF	PART #	DESCRIPTION
3101	P05273101	CONVEYOR TABLE
3102	P05273102	CONVEYOR BELT
3103	P05273103	GEARBOX FIX PLATE
3104	PW10M	FLAT WASHER 14MM
3105	PLW08M	LOCK WASHER 14MM
3106	PB100M	HEX BOLT M14-2 x 30
3107	P05273107	OUTFEED ROLLER
3108	PUCF205	BEARING UCF205
3110	PLW04	LOCK WASHER 3/8"
3111	PB18	HEX BOLT 3/8-16 x 1"
3112	PUCF205	BEARING UCF205
3113	PLW04	LOCK WASHER 3/8"
3114	PB18	HEX BOLT 3/8-16 x 1"
3115	P05273115	BEARING CAP
3116	PLW04	LOCK WASHER 3/8"
3117	PB24	HEX BOLT 3/8-16 x 1 1/4"
3118	P05273118	SPROCKET WHEEL
3119	PK11	KEY 5/16 x 5/16 X 1 3/16"
3120	PSS08	SETSCREW 5/16-18 x 1/2"
3121	P05273121	CHAIN
3123	P05273123	1/2 HP MOTOR
3123-1	P05273123-1	FAN COVER
3123-2	P05073123-2	FAN
3123-3	PC040A	CAPACITOR 40UF 350V
3123-4	P05273123-4	CAPACITOR COVER

REF	PART #	DESCRIPTION
3123-5	P05273123-5	WIRING COVER
3124	P05273124	SPROCKET WHEEL
3125	PSS08	SETSCREW 5/16-18 x 1/2"
3128	P05273128	CHAIN GUARD
3130	PSB75	CAP SCREW 5/16-18 x 3"
3131	P05273131	INFEED ROLLER BRACKET
3132	PSB16	CAP SCREW 3/8-16 x 3/4"
3133	P05273133	INFEED ROLLER BRACKET
3135	P05273135	CONVEYOR BELT WHEEL
3136	PSB70	CAP SCREW 5/16-18 x 2"
3137	PLW01	LOCK WASHER 5/16"
3138	PN02	HEX NUT 5/16-18
3140	P05273140	FRONT BRAKE COVER
3141	PS19	PHLP HD SCR 1/4-20 x 1"
3142	P05273142	LIMIT SWITCH
3143	PS10	PHLP HD SCR 10-24 x 1 1/2"
3144	PB92	HEX BOLT 1/2-12 x 3 1/2"
3201	P05273201	INFEED ROLLER SHAFT
3202	P05273202	INFEED ROLLER
3203	P6205	BALL BEARING 6205
3204	P05273204	EXT. RETAINING RING 35MM
3205	P05273205	ELEVATION LIMITER
3206	PSB62	CAP SCREW 1/4-20 x 1 1/2"
3207	P05273207	HOST PATH OF TABLE
3208	PSB07	CAP SCREW 5/16-18 x 3/4"

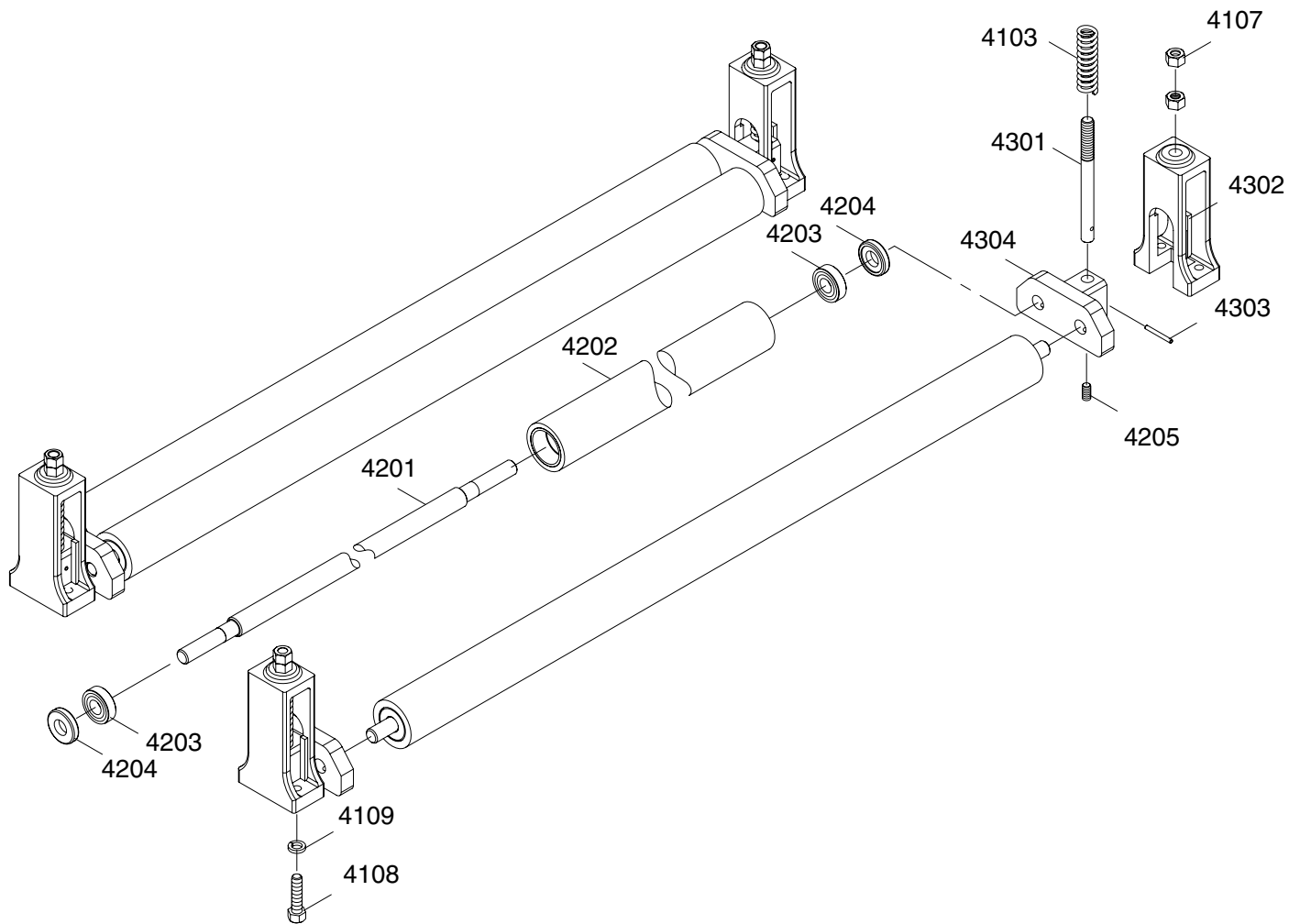

REF	PART #	DESCRIPTION
-----	--------	-------------

4103	P05274103	SPRING
4107	PN08	HEX NUT $\frac{3}{8}$ "-16
4108	PB07	HEX BOLT $\frac{5}{16}$ -18 x $\frac{3}{4}$ "
4109	PLW01	LOCK WASHER $\frac{5}{16}$ "
4201	P05274201	PISTON ROLLER SHAFT
4202	P05274202	PISTON ROLLER
4203	P6001	BALL BEARING 6001ZZ
4204	P05274204	SHAFT BEARING COLLAR
4205	PSS07	SETSCREW $\frac{1}{4}$ -20 x $\frac{1}{2}$ "
4301	P05274301	PISTON ROLLER ADJ. ROD
4302	P05274302	PISTON BRACKET
4303	PRP55M	ROLL PIN 3 X 27MM
4304	P05274304	PISTON SLIDERAIL

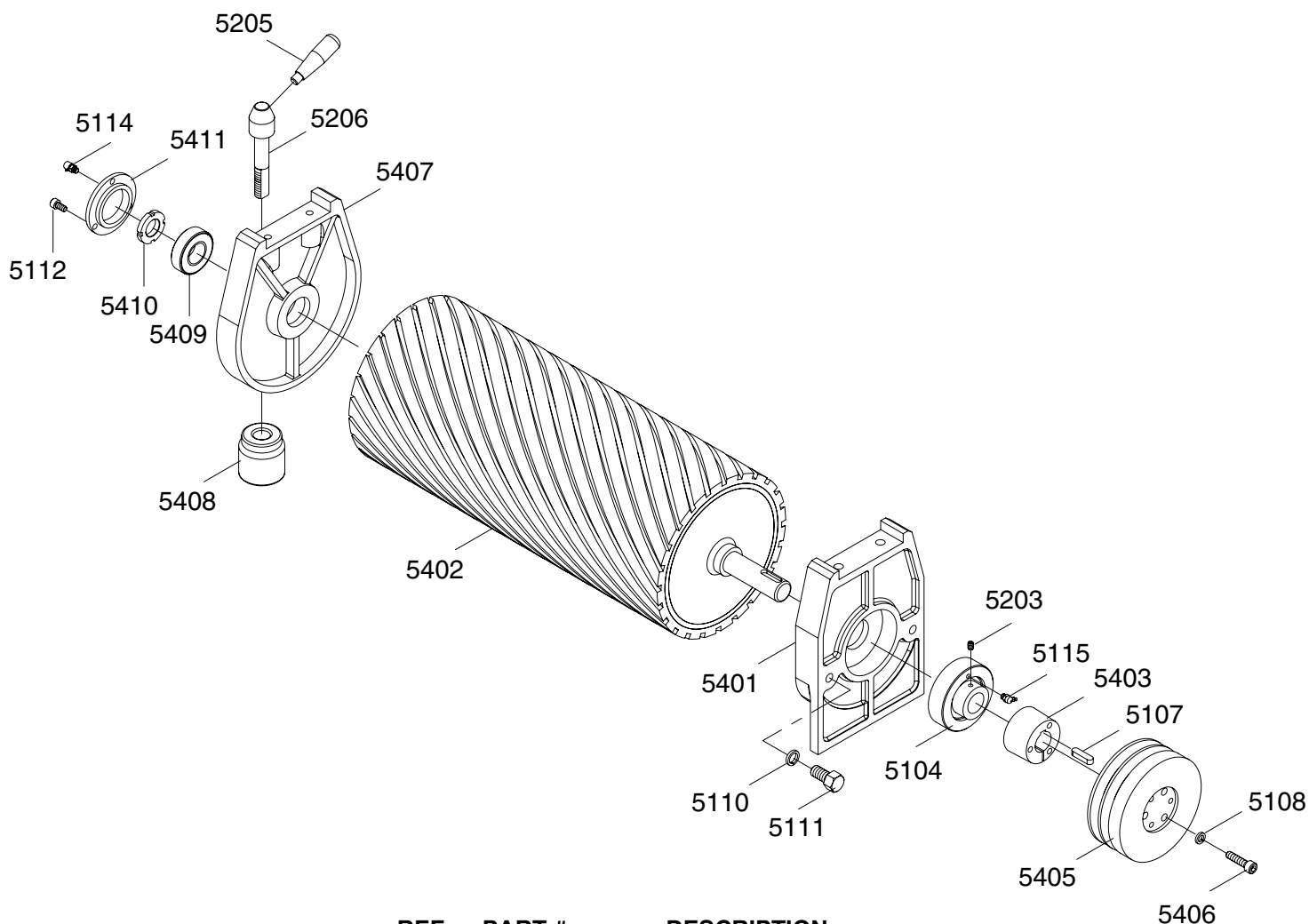

REF	PART #	DESCRIPTION
-----	--------	-------------

5104	P05275104	BALL BEARING UCC206
5107	PK11	KEY $\frac{5}{16}$ X $\frac{5}{16}$ X $1\frac{3}{16}$ "
5108	PLW01	LOCK WASHER $\frac{5}{16}$ "
5110	PLW07	LOCK WASHER $\frac{1}{2}$ "
5111	PB40	HEX BOLT $\frac{1}{2}$ -12 X $1\frac{1}{4}$ "
5112	PSB04	CAP SCREW $\frac{1}{4}$ -20 X $\frac{1}{2}$ "
5114	P05275114	FILTER
5115	P05275115	PT $\frac{1}{16}$ " 90° GREASE FITTING
5203	PSB85M	CAP SCREW M6-1 X 6
5205	P05275205	HANDLE
5206	P05275206	HOLD DOWN ROD
5401	P05275401	BEARING HOUSING
5402	P05275402	RUBBER ROLLER
5403	P05275403	FASTENING TUBE
5405	P05275405	PULLEY
5406	PSB11	CAP SCREW $\frac{5}{16}$ "-18 X $1\frac{1}{4}$ "
5407	P05275407	BEARING HOUSING
5408	P05275408	BEARING BRACKET PAD
5409	P6205	BALL BEARING 6205-2RS
5410	P05275410	RING
5411	P05275411	BEARING CAP

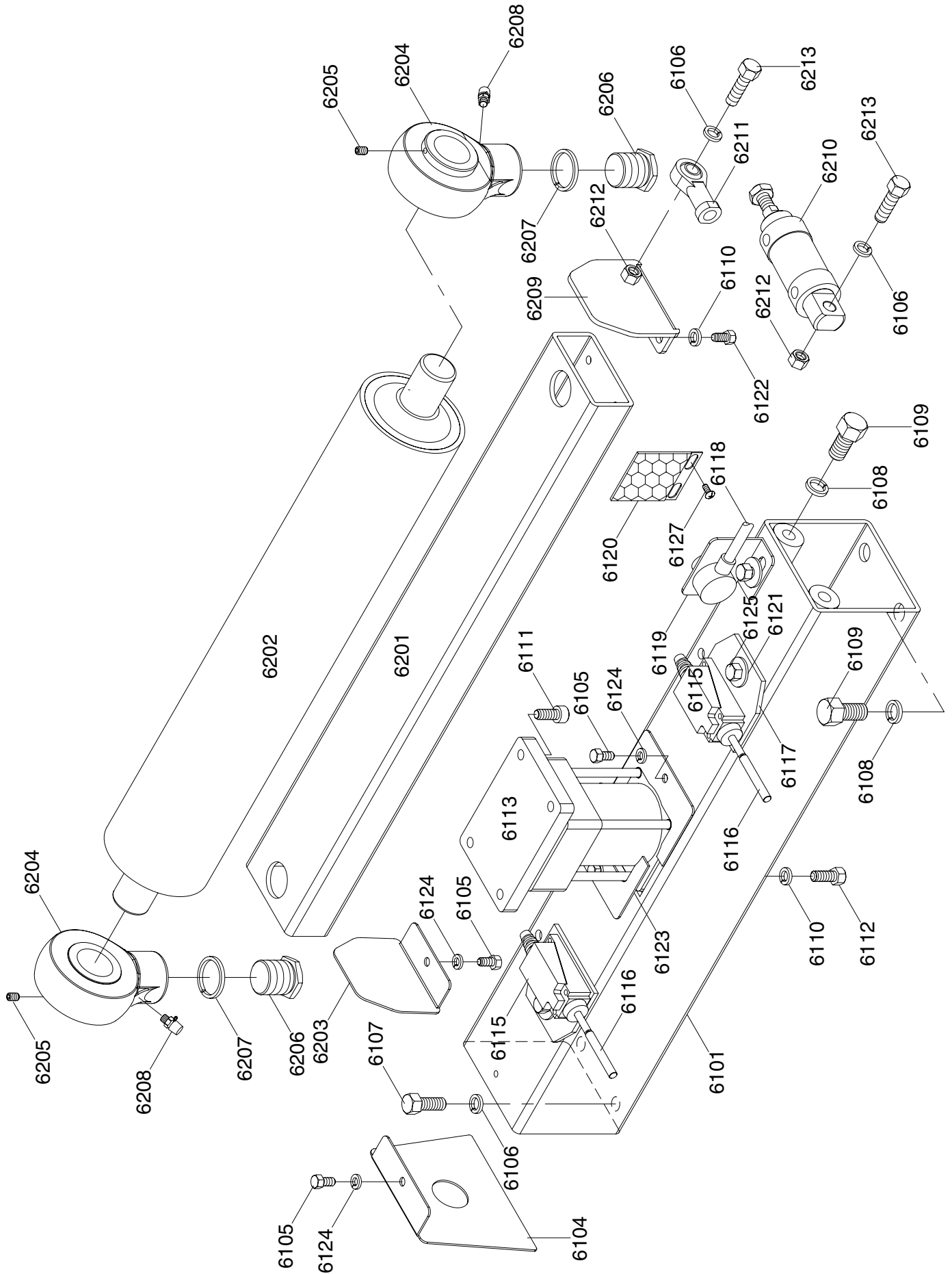



REF	PART #	DESCRIPTION
6101	P05276101	SQUARE FRAME
6104	P05276104	SQUARE FRAME SEAL (LEFT)
6105	PB193	HEX BOLT 1/4-20 x 1/2"
6106	PLW04	LOCK WASHER 3/8"
6107	PB18	HEX BOLT 3/8-16 x 1"
6108	PLW07	LOCK WASHER 1/2"
6109	PB53	HEX BOLT 1/2-12 x 1"
6110	PLW01	LOCK WASHER 5/16"
6111	PSB07	CAP SCREW 5/16-18 x 3/4"
6112	PB09M	HEX BOLT M8-1.25 x 20
6113	P05276113	AIR CYLINDER
6115	P05276115	LIMIT SWITCH
6116	P05276116	LIMIT SWITCH TUBE
6117	P05276117	LIMIT SWITCH HOLDER
6118	P05276118	SENSOR
6119	P05276119	SENSOR PLATE
6120	P05276120	MIRROR OF SENSOR
6121	PW07	FLAT WASHER 5/16"
6122	PB09	HEX BOLT 5/16-18 x 1/2"

REF	PART #	DESCRIPTION
6123	P05276123	COVER OF AIR CYLINDER
6124	PLW02	LOCK WASHER 1/4"
6125	PB07	HEX BOLT 5/16-18 x 3/4"
6127	PS07M	PHLP HD SCR M4-.7 x 8
6201	P05276201	UPPER ROLLER BRACKET
6202	P05276202	UPPER ROLLER
6203	P05276203	COVER UPPER ROLLER (LEFT)
6204	P05276204	BALL BEARING UCECH206
6205	PSS02M	SETSCREW M6-1 x 6
6206	P05276206	CAP SCREW 3/4-16 x 1"
6207	P05276207	RING
6208	P05276208	FILTER
6209	P05276209	COVER UPPER ROLLER (RIGHT)
6210	P05276210	AIR CYLINDER
6211	P05276211	BALL BEARING PHS-10
6212	PN08	HEX NUT 3/8-16
6213	PB24	HEX BOLT 3/8-16 x 1 1/4"

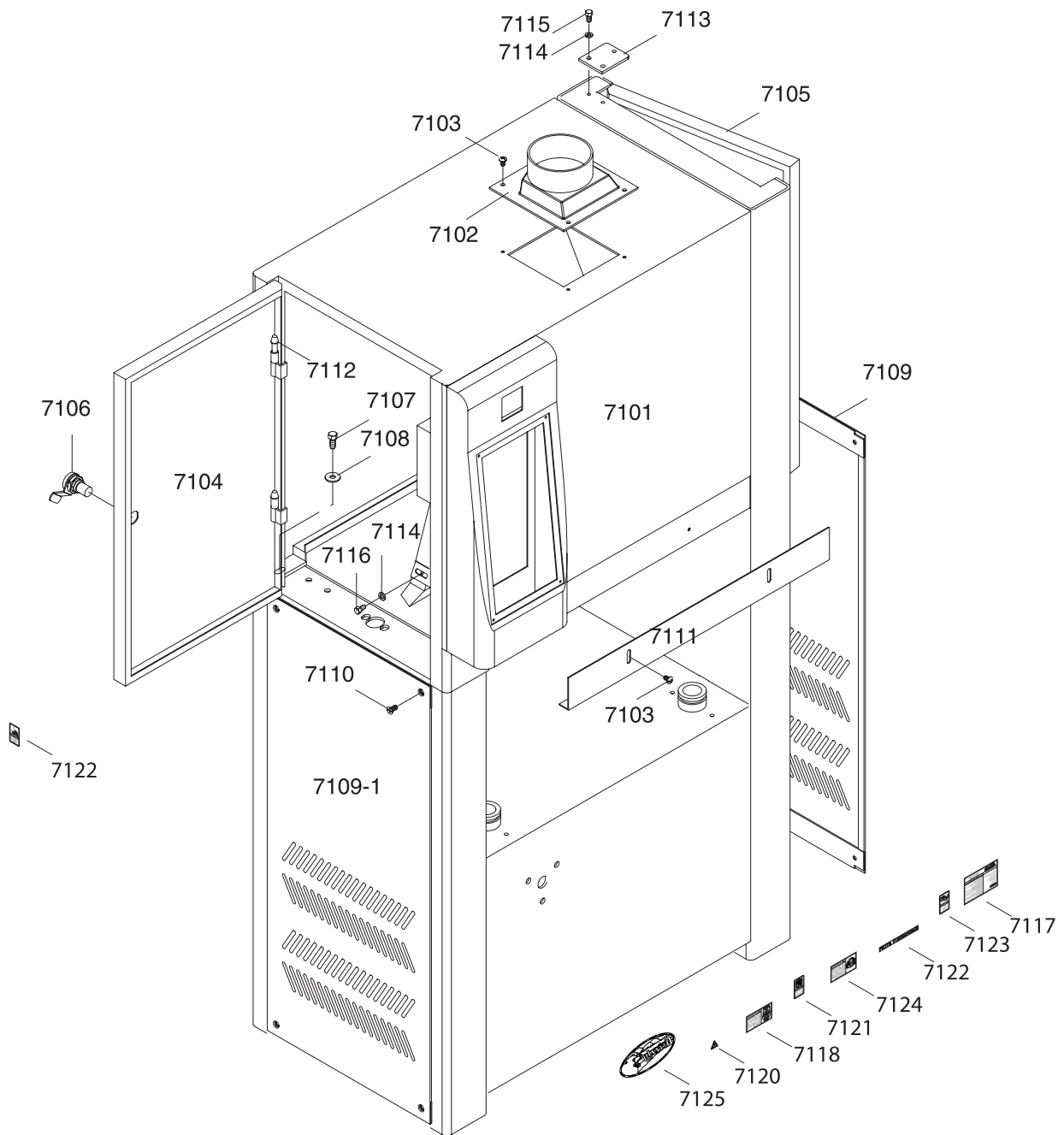

REF	PART #	DESCRIPTION
7101	P05277101	UPPER FRAME COVER
7102	P05277102	DUST HOOD 4"
7103	PS24M	PHLP HD SCR M6-1 x 10
7104	P05277104	LEFT DOOR, UPPER FRAME
7105	P05277105	RIGHT DOOR, UPPER FRAME
7106	P05277106	DOOR LOCK
7107	PB03	HEX BOLT $\frac{5}{16}$ -18 x 1"
7108	PW07	FLAT WASHER $\frac{5}{16}$ "
7109	P05277109	RIGHT DOOR, LOWER FRAME
7109-1	P05277109-1	LEFT DOOR, LOWER FRAME
7110	PS04	PHLP HD SCR $\frac{1}{4}$ -20 x $\frac{1}{2}$ "
7111	P05277111	PROTECTION AL PLATE
7112	P05277112	HINGE

REF	PART #	DESCRIPTION
7113	P05277113	PLATE
7114	PLW02	LOCK WASHER $\frac{1}{4}$ "
7115	PB19	HEX BOLT $\frac{1}{4}$ -20 x $\frac{1}{2}$ "
7116	PB02M	HEX BOLT M6-1 x 12
7117	P05277117	MACHINE ID LABEL
7118	P05277118	FEED ONE PIECE LABEL
7119	PLABEL-13	UNPLUG LABEL (2)
7120	PLABEL-14	ELECTRICITY LABEL
7121	PLABEL-12	READ MANUAL LABEL
7122	P05277122	EMERGENCY STOP LABEL
7123	PLABEL-11	SAFETY GLASSES LABEL
7124	P05277124	NO STANDING LABEL
7125	G8589	CAST LOGO

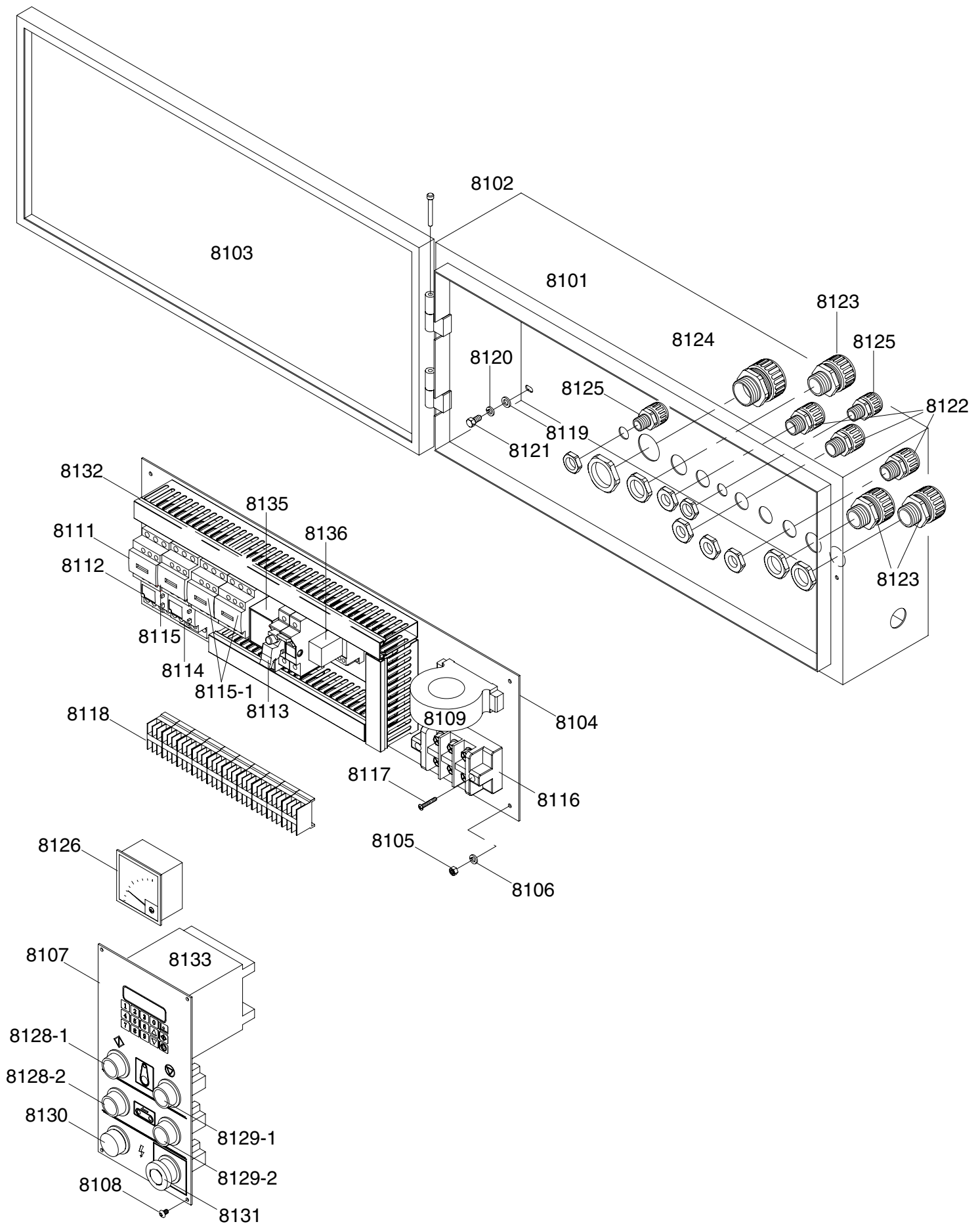

REF	PART #	DESCRIPTION
8101	P05278101	ELECTRICAL CONTROL BOX
8102	P05278102	HINGE
8103	P05278103	CONTROL BOX OF DOOR
8104	P05278104	BASE PLATE
8105	PN05	HEX NUT 1/4-20
8106	PLW02	LOCK WASHER 1/4"
8107	P05278107	CONTROL PANEL
8108	PS07M	PHLP HD SCR M4-.7 x 8
8109	P05278109	CURRENT DEVICE
8111	P05278111	CONTACTOR LC1D386M7
8112	P05278112	RELAY LRD356 (30-38A)
8113-1	P05278113	4A FUSE
8114	P05278114	RELAY LR3D-086 (2.5-4A)
8115	P05278115	CONTACTOR LC1D96M7
8116	P05278116	POWER WIRE TERMINAL
8117	PS51M	PHLP HD SCR M4-.7 x 30
8118	P05278118	TERMINAL PLATE
8119	PW06	FLAT WASHER 1/4"

REF	PART #	DESCRIPTION
8120	PLW02	LOCK WASHER 1/4"
8121	PB19	HEX BOLT 1/4-20 x 1/2"
8122	P05278122	PU CONNECTOR 1/2"
8123	P05278123	PU CONNECTOR 3/4"
8124	P05278124	CABLE CONNECTOR 1"
8125	P05278125	PU CONNECTOR 3/8"
8126	P05278126	AMP METER
8128-1	P05278128-1	START SWITCH
8128-2	P05278128-2	START SWITCH
8129-1	P05278129-1	STOP SWITCH
8129-2	P05278129-2	STOP SWITCH
8130	P05278130	POWER INDICATION LIGHT
8131	P05278131	EMERGENCY STOP SWITCH
8132	P05278132	WIRE COLUMN
8133	P05278133	COMPUTER
8135	P05278135	CONTROLLER UNIT
8136	P05278136	RELAY
8137	P05278137	CNTAC. LC1D96M7 (W/LOCK)

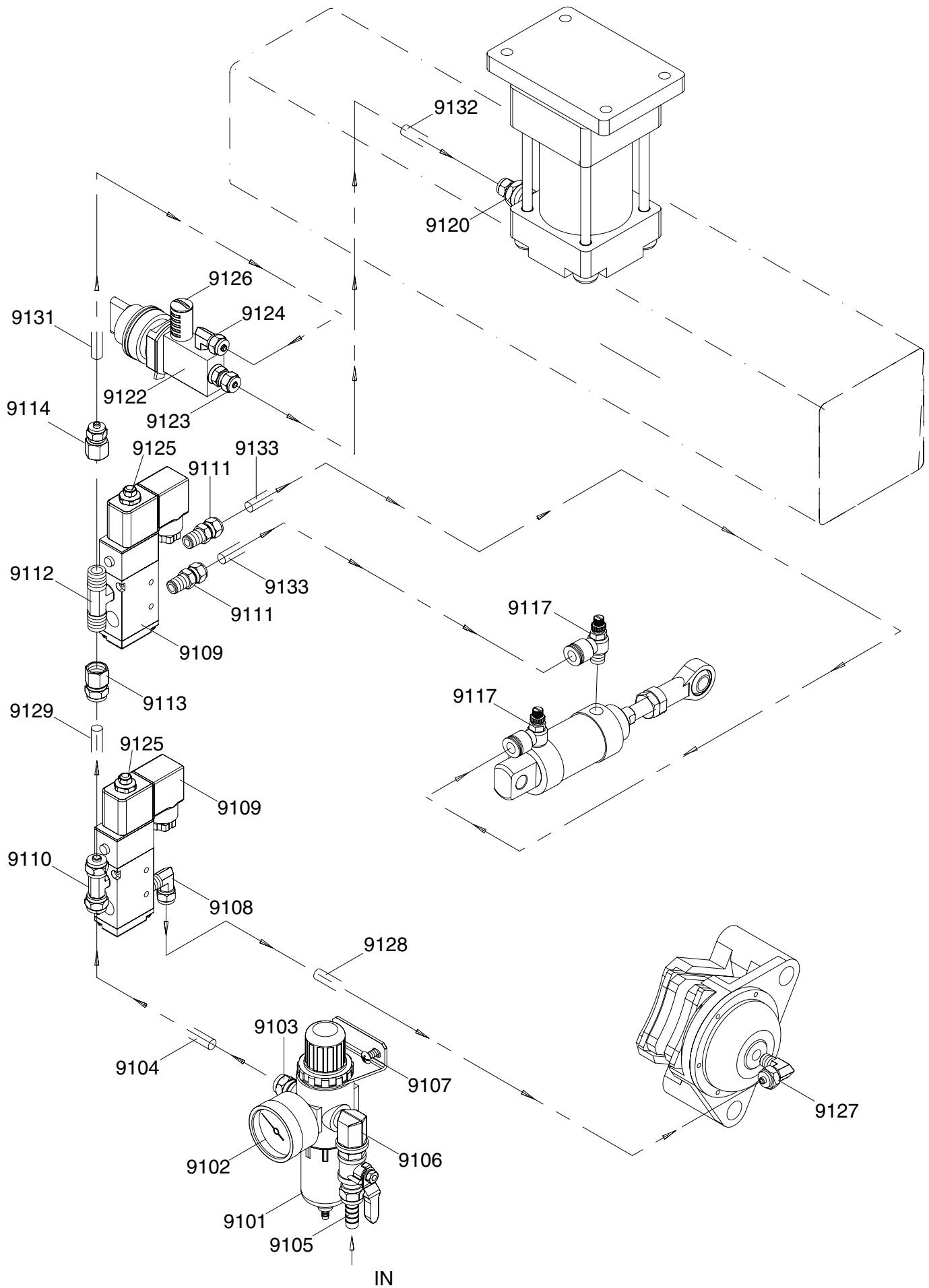

REF	PART #	DESCRIPTION
9101	P05279101	FILTER CUP 1/4"
9102	P05279102	PRESSURE REGULATOR 1/4"
9103	P05279103	BRONZE CONN. 1/4"T x 5/16"N
9104	P05279104	FLEXIBLE HOSE 8MM
9105	P05279105	AIR SWITCH 1/4"
9106	P05279106	ELBOW 1/4"T x 5/16"N
9107	PS22	PHLP HD SCR 10-24 x 5/8"
9108	P05279108	ELBOW 1/4" x 1/8"T
9109	P05279109	SOLENOID VALVE
9110	P05279110	T-JOINT 5/16"N x 1/8"T x 5/16"N
9111	P05279111	PLASTIC CONN. 1/4" N x 1/4"T
9112	P05279112	T-JOINT 1/4"T x 1/4"T x 1/4"T
9113	P05279113	PLASTIC CONN. 5/16"N x 1/4"T
9114	P05279114	PLASTIC CONN. 1/4"N x 1/4"T

REF	PART #	DESCRIPTION
9117	P05279117	THROTTLE VALVE 1/8"
9120	P05279120	PLASTIC CONN. 1/4"N x 3/8"T
9122	P05279122	AIR SWITCH 1/8"
9123	P05279123	PLASTIC CONN. 1/4"N x 1/8"T
9124	P05279124	PLASTIC CONN. 1/4"N x 1/8"T-90°
9125	P05279125	BUFFER 1/8"
9126	P05279126	SILENCER 1/8"
9127	P05279127	PLASTIC CONN. 5/16"N x 1/8"T
9128	P05279128	FLEXIBLE HOSE 8MM
9129	P05279129	FLEXIBLE HOSE 8MM
9131	P05279131	FLEXIBLE HOSE 6MM
9132	P05279132	FLEXIBLE HOSE 6MM
9133	P05279133	FLEXIBLE HOSE 6MM

# Machine Troubleshooting

SYMPTOM	POSSIBLE CAUSE	CORRECTIVE ACTION
Sanding belt does not tension correctly; rollers slip under belt.	<ol style="list-style-type: none"> <li>1. Low air pressure.</li> <li>2. Air leaks in system.</li> </ol>	<ol style="list-style-type: none"> <li>1. Adjust air pressure to 75 PSI at primary regulator.</li> <li>2. Inspect all hoses and connections for leaking air; use water on suspected area to detect bubbles.</li> </ol>
Sanding belt runs off to one side, stopping the sander.	<ol style="list-style-type: none"> <li>1. Air eye fork clogged.</li> <li>2. Oscillation return valve closed.</li> <li>3. Oscillation timing incorrect.</li> </ol>	<ol style="list-style-type: none"> <li>1. Clean the intake hole on the air eye fork.</li> <li>2. Open valve.</li> <li>3. Adjust oscillation timing.</li> </ol>
Sanding belt will not start.	<ol style="list-style-type: none"> <li>1. Sanding belt is not tensioned.</li> <li>2. Limit switches engaged.</li> <li>3. Emergency stop plate engaged.</li> </ol>	<ol style="list-style-type: none"> <li>1. Tension sanding belt.</li> <li>2. Center sanding belt so it is not touching the limit switches.</li> <li>3. Make sure emergency stop switch is released.</li> </ol>
Motor will not start.	<ol style="list-style-type: none"> <li>1. Low voltage.</li> <li>2. Open circuit in motor or loose connections.</li> </ol>	<ol style="list-style-type: none"> <li>1. Check power line for proper voltage.</li> <li>2. Inspect all lead connections on motor for loose or open connections.</li> </ol>
Motor will not start; fuses or circuit breakers blow.	<ol style="list-style-type: none"> <li>1. Short circuit in line cord or plug.</li> <li>2. Short circuit in motor or loose connections.</li> <li>3. Incorrect fuses or circuit breakers in power line.</li> </ol>	<ol style="list-style-type: none"> <li>1. Inspect cord or plug for damaged insulation and shorted wires.</li> <li>2. Inspect all connections on motor for loose or shorted terminals or worn insulation.</li> <li>3. Install correct fuses or circuit breakers.</li> </ol>
Motor overheats.	<ol style="list-style-type: none"> <li>1. Motor overloaded.</li> <li>2. Air circulation through the motor restricted.</li> </ol>	<ol style="list-style-type: none"> <li>1. Reduce load on motor.</li> <li>2. Clean out motor to provide normal air circulation.</li> </ol>
Motor stalls (resulting in blown fuses or tripped circuit).	<ol style="list-style-type: none"> <li>1. Short circuit in motor or loose connections.</li> <li>2. Low voltage.</li> <li>3. Incorrect fuses or circuit breakers in power line.</li> <li>4. Motor overloaded.</li> </ol>	<ol style="list-style-type: none"> <li>1. Inspect connections on motor for loose or shorted terminals or worn insulation.</li> <li>2. Correct the low voltage conditions.</li> <li>3. Install correct fuses or circuit breakers.</li> <li>4. Reduce load on motor.</li> </ol>
Loud, repetitious noise coming from machine.	<ol style="list-style-type: none"> <li>1. Pulley set screws or keys are missing or loose.</li> <li>2. Motor fan is hitting the cover.</li> <li>3. V-belt is defective.</li> </ol>	<ol style="list-style-type: none"> <li>1. Inspect keys and set screws. Replace or tighten if necessary.</li> <li>2. Tighten fan or shim cover.</li> <li>3. Replace V-belt. See <i>Maintenance</i> section.</li> </ol>
Conveyor belt not tracking in center.	<ol style="list-style-type: none"> <li>1. Conveyor rollers moved out of adjustment.</li> </ol>	<ol style="list-style-type: none"> <li>1. Re-adjust conveyor rollers.</li> </ol>
Conveyor belt slipping.	<ol style="list-style-type: none"> <li>1. Conveyor rollers have incorrect tension.</li> <li>2. Conveyor rollers contaminated with dirt or dust.</li> </ol>	<ol style="list-style-type: none"> <li>1. Adjust conveyor rollers to place more tension on .</li> <li>2. Clean conveyor rollers.</li> </ol>
Emergency brake stops slow.	<ol style="list-style-type: none"> <li>1. Air pressure incorrect.</li> <li>2. Air leak in system.</li> <li>3. Brake rotor contaminated with oil.</li> <li>4. Brake pads worn out.</li> </ol>	<ol style="list-style-type: none"> <li>1. Adjust air pressure to 75 PSI,</li> <li>2. Find and fix air leaks.</li> <li>3. Clean brake rotor with automotive brake parts cleaner.</li> <li>4. Replace brake pads.</li> </ol>
Grinding noise when braking.	<ol style="list-style-type: none"> <li>1. Brakes severely worn out.</li> </ol>	<ol style="list-style-type: none"> <li>1. Replace brake pads, have rotor turned (possibly replaced).</li> </ol>
Machine slows when operating.	<ol style="list-style-type: none"> <li>1. Feed rate too high.</li> <li>2. Depth of cut too great.</li> </ol>	<ol style="list-style-type: none"> <li>1. Feed workpiece slower.</li> <li>2. Reduce depth of cut.</li> </ol>



# Sanding Troubleshooting

SYMPTOM	POSSIBLE CAUSE	CORRECTIVE ACTION
Lines across width of workpiece.	1. Sanding belt seam is open or damaged.	1. Repair or replace sanding belt.
Glossy spots or streaks on workpiece.	1. Worn sanding belt. 2. Rear pressure roller too low.	1. Replace sanding belt. 2. Raise rear pressure roller. <b>(See warning in Pressure Roller section!)</b>
Sanding belt clogs quickly.	1. Sanding belt grit too small for particular job. 2. Excessive depth of cut. 3. Wood is too moist.	1. Replace with a coarser grit sanding belt. 2. Reduce depth of cut. 3. Allow wood to dry out.
Poor, non-aggressive sanding results.	1. Worn sanding belt. 2. Sanding belt loaded with sawdust.	1. Replace sanding belt with a new one. 2. Clean sanding belt to unload sawdust.
Machine is loud, overheats or bogs down in the cut.	1. Excessive depth of cut. 2. Dull sanding belt.	1. Decrease depth of cut. 2. Replace sanding belt.
Edges of wood are rounded.	1. Excessive depth of cut.	1. Reduce depth of cut.
Uneven thickness from left to right of board.	1. Feed table not parallel to sanding roller. 2. Feed belt is worn.	1. Adjust the table. 2. Replace feed belt.
Workpiece slips on feed belt.	1. Pressure rollers set too high. 2. Dirty feed belt. 3. Feed belt is worn.	1. Lower pressure rollers. 2. Clean feed belt. 3. Replace feed belt.
Straight strip of notches on workpiece.	1. Pressure rollers are dirty or damaged.	1. Clean or repair pressure rollers.
Snake shaped marks on workpiece.	1. Sanding belt damaged or dirty.	1. Clean or replace sanding belt.



	<p><b>⚠ WARNING</b></p> <p>For your safety, turn switch off and disconnect the machine from power source before troubleshooting the machine. Please refer to <i>Section 5: Set Up</i> to make corrections.</p>
--	--



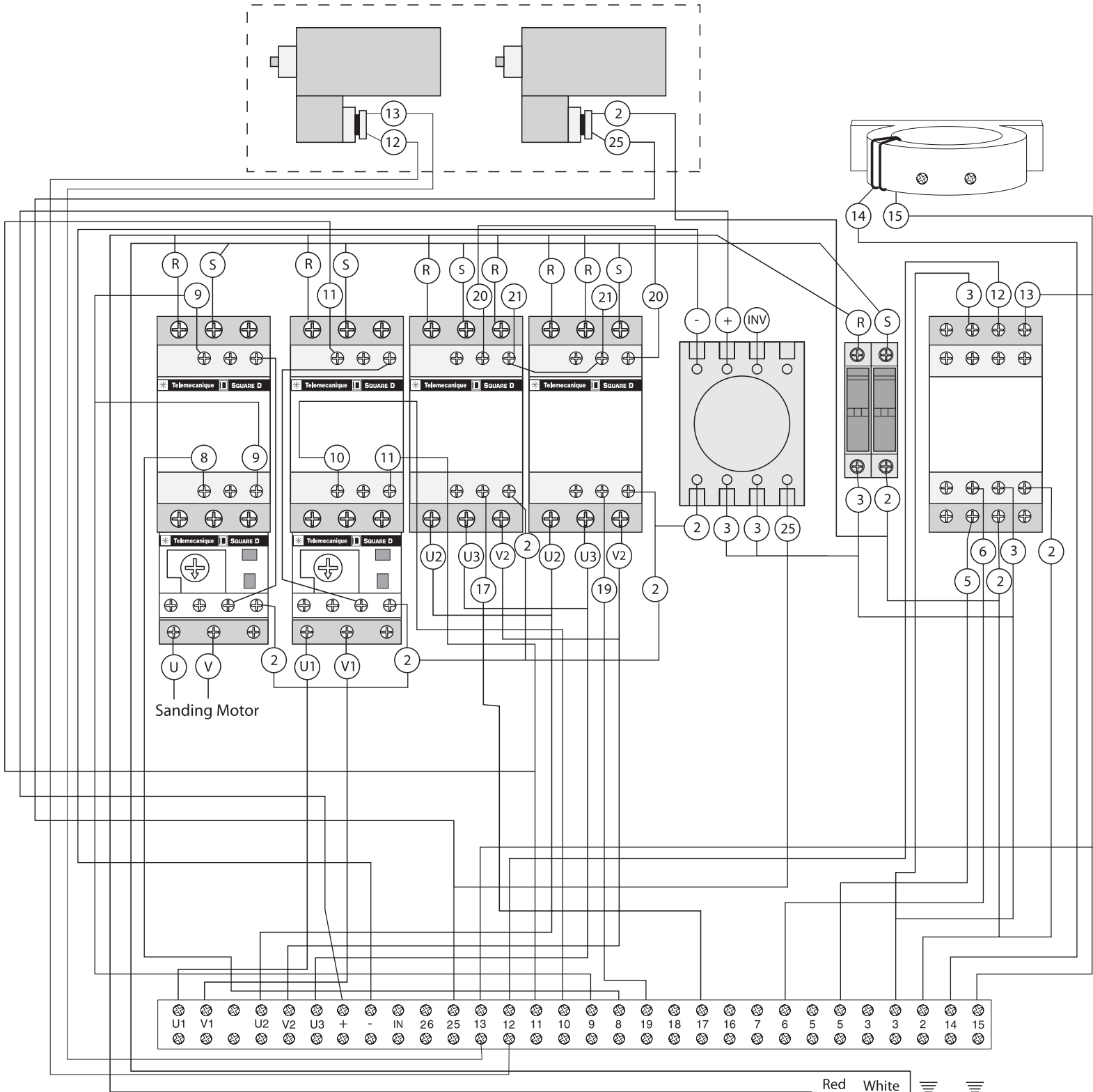

**! DANGER**  
Disconnect power from machine before performing any electrical service. Failure to do this will result in a shock hazard leading to injury or death.

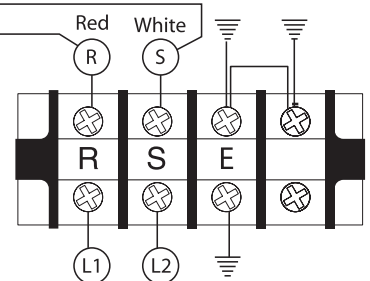

## G0527 18" WIDE BELT SANDER WIRING DIAGRAM - SWITCH PANEL CONTROL PANEL VIEWED FROM BACK

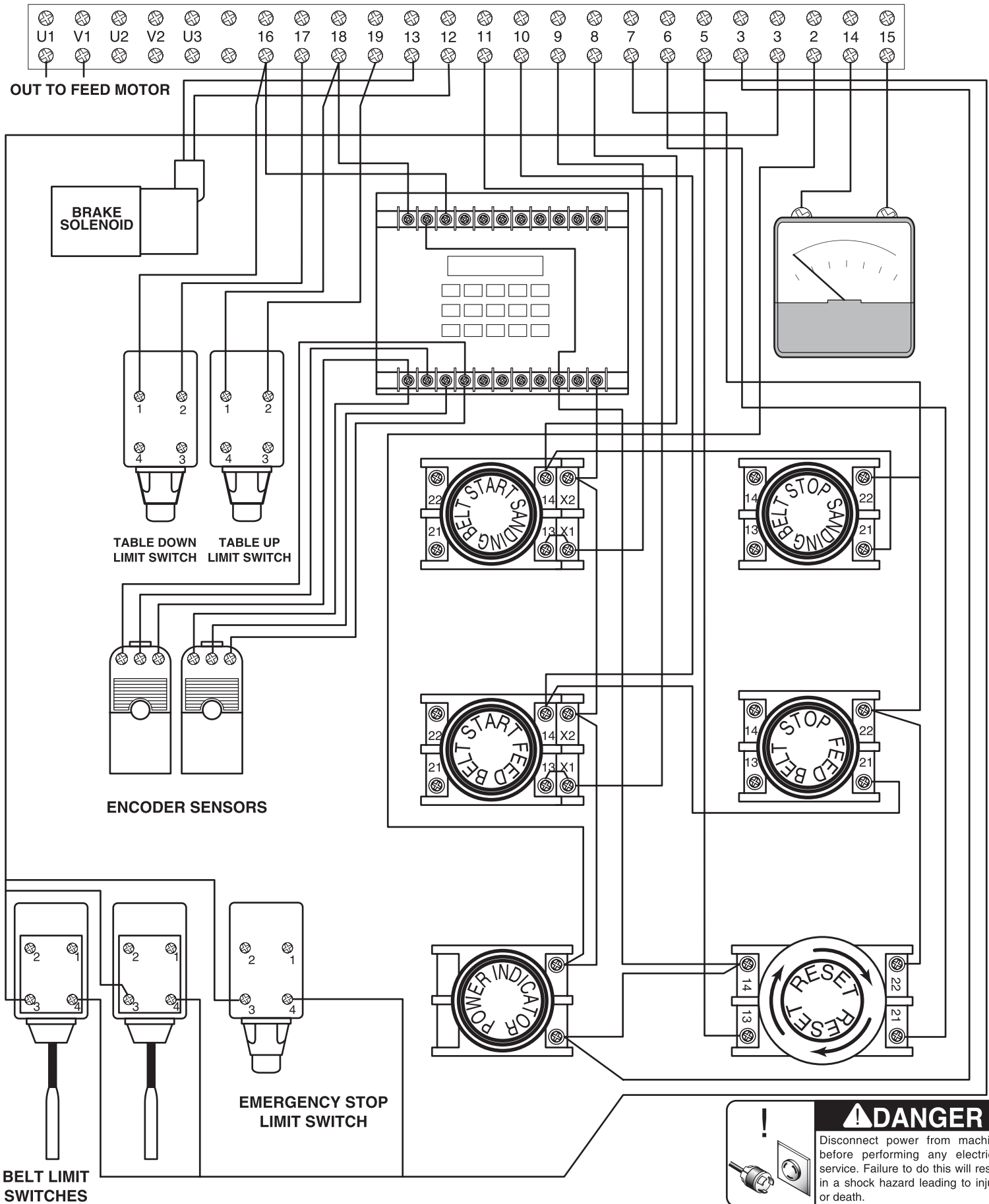

**! DANGER**

Disconnect power from machine before performing any electrical service. Failure to do this will result in a shock hazard leading to injury or death.

# Notes

---

---



# Warranty & Returns

---

---

Grizzly Industrial, Inc. warrants every product it sells for a period of **1 year** to the original purchaser from the date of purchase. This warranty does not apply to defects due directly or indirectly to misuse, abuse, negligence, accidents, repairs or alterations or lack of maintenance. This is Grizzly's sole written warranty and any and all warranties that may be implied by law, including any merchantability or fitness, for any particular purpose, are hereby limited to the duration of this written warranty. We do not warrant or represent that the merchandise complies with the provisions of any law or acts unless the manufacturer so warrants. In no event shall Grizzly's liability under this warranty exceed the purchase price paid for the product and any legal actions brought against Grizzly shall be tried in the State of Washington, County of Whatcom.

We shall in no event be liable for death, injuries to persons or property or for incidental, contingent, special, or consequential damages arising from the use of our products.

To take advantage of this warranty, contact us by mail or phone and give us all the details. We will then issue you a "Return Number," which must be clearly posted on the outside as well as the inside of the carton. We will not accept any item back without this number. Proof of purchase must accompany the merchandise.

The manufacturers reserve the right to change specifications at any time because they constantly strive to achieve better quality equipment. We make every effort to ensure that our products meet high quality and durability standards and we hope you never need to use this warranty.

Please feel free to write or call us if you have any questions about the machine or the manual.

Thank you again for your business and continued support. We hope to serve you again soon.



# WARRANTY CARD

Name \_\_\_\_\_  
Street \_\_\_\_\_  
City \_\_\_\_\_ State \_\_\_\_\_ Zip \_\_\_\_\_  
Phone Number \_\_\_\_\_ E-Mail \_\_\_\_\_ FAX \_\_\_\_\_  
MODEL # \_\_\_\_\_ Serial # \_\_\_\_\_ Order # \_\_\_\_\_

The following information is given on a voluntary basis. It will be used for marketing purposes to help us develop better products and services. Of course, all information is strictly confidential.

1. How did you learn about us?
- Advertisement                       Friend  
 Catalog                                 Card Deck  
 World Wide Web  
  
 Other \_\_\_\_\_
2. Which of the following magazines do you subscribe to.
- American Woodworker                 Practical Homeowner  
 Cabinetmaker                           Shop Notes  
 Family Handyman                       Today's Homeowner  
 Fine Homebuilding                     WOOD  
 Fine Woodworking                     Wooden Boat  
 Home Handyman                         Woodshop News  
 Journal of Light Construction        Woodsmith  
 Old House Journal                     Woodwork  
 Popular Mechanics                     Woodworker  
 Popular Science                         Woodworker's Journal  
 Popular Woodworking                 Workbench  
  
 Other \_\_\_\_\_
3. Which of the following woodworking/remodeling shows do you watch?
- Backyard America                     The New Yankee Workshop  
 Home Time                               This Old House  
 The American Woodworker         Woodwright's Shop  
  
 Other \_\_\_\_\_
4. What is your annual household income?
- \$20,000-\$29,999                       \$60,000-\$69,999  
 \$30,000-\$39,999                       \$70,000-\$79,999  
 \$40,000-\$49,999                       \$80,000-\$89,999  
 \$50,000-\$59,999                       \$90,000 +
5. What is your age group?
- 20-29                                       50-59  
 30-39                                       60-69  
 40-49                                       70 +
6. How long have you been a woodworker?
- 0 - 2 Years                               8 - 20 Years  
 2 - 8 Years                               20+ Years
7. How would you rank your woodworking skills?
- Simple                                       Advanced  
 Intermediate                               Master Craftsman
8. What stationary woodworking tools do you own? Check all that apply.
- Air Compressor                         Panel Saw  
 Bandsaw                                    Planer  
 Drill Press                                 Power Feeder  
 Drum Sander                               Radial Arm Saw  
 Dust Collector                            Shaper  
 Horizontal Boring Machine            Spindle Sander  
 Jointer                                       Table Saw  
 Lathe                                         Vacuum Veneer Press  
 Mortiser                                    Wide Belt Sander  
  
 Other \_\_\_\_\_
9. How many of your woodworking machines are Grizzly? \_\_\_\_\_
10. Which benchtop tools do you own? Check all that apply.
- 1" x 42" Belt Sander                     6" - 8" Grinder  
 5" - 8" Drill Press                       Mini Lathe  
 8" Table Saw                               10" - 12" Thickness Planer  
 8" - 10" Bandsaw                        Scroll Saw  
 Disc/Belt Sander                         Spindle/Belt Sander  
 Mini Jointer  
  
 Other \_\_\_\_\_
11. How many of the machines checked above are Grizzly? \_\_\_\_\_
12. Which portable/hand held power tools do you own? Check all that apply.
- Belt Sander                                Orbital Sander  
 Biscuit Joiner                            Palm Sander  
 Circular Saw                               Portable Planer  
 Detail Sander                               Saber Saw  
 Drill/Driver                                Reciprocating Saw  
 Miter Saw                                  Router  
  
 Other \_\_\_\_\_
13. What machines/supplies would you like Grizzly Industrial to carry?  
\_\_\_\_\_  
\_\_\_\_\_
14. What new accessories would you like Grizzly Industrial to carry?  
\_\_\_\_\_  
\_\_\_\_\_
15. What other companies do you purchase your tools and supplies from?  
\_\_\_\_\_  
\_\_\_\_\_
16. Do you think your purchase represents good value?  
 Yes     No
17. Would you recommend Grizzly Industrial to a friend?  
 Yes     No
18. Would you allow us to use your name as a reference for Grizzly customers in your area? **Note: We never use names more than three times.**  
 Yes     No
19. Comments: \_\_\_\_\_  
\_\_\_\_\_  
\_\_\_\_\_  
\_\_\_\_\_

CUT ALONG DOTTED LINE

FOLD ALONG DOTTED LINE

---

---

---



Place  
Stamp  
Here



**GRIZZLY INDUSTRIAL, INC.**  
**P.O. BOX 2069**  
**BELLINGHAM, WA 98227-2069**



FOLD ALONG DOTTED LINE

Send a Grizzly Catalog to a friend:

Name _____
Street _____
City _____ State _____ Zip _____

TAPE ALONG EDGES--PLEASE DO NOT STAPLE



# grizzly.com

**TOOL WEBSITE**

Buy Direct and Save with Grizzly® – Trusted, Proven and a Great Value!

Visit Our Website Today And Discover Why  
Grizzly® Is The Industry Leader!

- 
- 
- 

**B**

**A**

**B**

**G**

**1-800-523-4777**





## Free Manuals Download Website

<http://myh66.com>

<http://usermanuals.us>

<http://www.somanuals.com>

<http://www.4manuals.cc>

<http://www.manual-lib.com>

<http://www.404manual.com>

<http://www.luxmanual.com>

<http://aubethermostatmanual.com>

Golf course search by state

<http://golfingnear.com>

Email search by domain

<http://emailbydomain.com>

Auto manuals search

<http://auto.somanuals.com>

TV manuals search

<http://tv.somanuals.com>