



**15" OPEN-END  
WIDE-BELT SANDER  
MODEL G9983  
INSTRUCTION MANUAL**



COPYRIGHT © OCTOBER, 2002 BY GRIZZLY INDUSTRIAL, INC.  
**WARNING: NO PORTION OF THIS MANUAL MAY BE REPRODUCED IN ANY SHAPE  
OR FORM WITHOUT THE WRITTEN APPROVAL OF GRIZZLY INDUSTRIAL, INC.**  
PRINTED IN TAIWAN

# WARNING

Some dust created by power sanding, sawing, grinding, drilling, and other construction activities contains chemicals known to the State of California to cause cancer, birth defects or other reproductive harm. Some examples of these chemicals are:

- Lead from lead-based paints.
- Crystalline silica from bricks, cement, and other masonry products.
- Arsenic and chromium from chemically treated lumber.

Your risk from these exposures varies, depending on how often you do this type of work. To reduce your exposure to these chemicals: work in a well ventilated area, and work with approved safety equipment, such as those dust masks that are specially designed to filter out microscopic particles.

# Table Of Contents

	PAGE
<b>1. SAFETY</b>	
SAFETY RULES FOR POWER TOOLS .....	2-3
SAFETY RULES FOR THE WIDE BELT SANDER .....	4
<b>2. INTRODUCTION</b> .....	5
<b>3. CIRCUIT REQUIREMENTS</b> .....	6
220V SINGLE-PHASE.....	6
GROUNDING .....	7
EXTENSION CORDS .....	7
WIRING .....	7
<b>4. MACHINE FEATURES</b> .....	8
EXTERNAL FEATURES .....	8
CONTROL PANEL .....	8
ACCESS DOORS .....	9
<b>5. SET UP</b> .....	10
UNPACKING .....	10
PIECE INVENTORY .....	10
HARDWARE RECOGNITION CHART .....	11
CLEAN UP.....	12
SITE CONSIDERATIONS .....	12
BEGINNING ASSEMBLY .....	13
HANDWHEEL HANDLE .....	13
PLATEN.....	14
AIR HOSE .....	15
SANDING BELT .....	15
SANDING BELT TENSION.....	16
PRESSURE ROLLERS .....	16
DUST COLLECTION.....	17
TEST RUN .....	17-18
RECOMMENDED ADJUSTMENTS .....	18
<b>6. OPERATIONS</b> .....	19
BEFORE STARTING.....	19
CHOOSING SANDPAPER .....	19
CONVEYOR HEIGHT .....	20
FEED BELT SPEED .....	20
LOAD METER .....	21
OPERATION .....	21
PLATEN DEPTH .....	22
CLEANING PADS .....	22
<b>7. MAINTENANCE</b> .....	23
GENERAL .....	23
LUBRICATION .....	23
CLEANING SANDING BELTS .....	23
EMPTYING FILTERS .....	23
MAINTENANCE LOG .....	24
<b>8. SERVICE ADJUSTMENTS</b> .....	25
OSCILLATION TIMING .....	25-26
OSCILLATION SPEED .....	26
OSCILLATION RETURN.....	27
LIMIT SWITCHES .....	27
PRESSURE ROLLER DEPTH .....	28
PRESSURE ROLLER TENSION .....	29
FEED BELT TENSION .....	30
FEED BELT TRACKING .....	30
V-BELT TENSION.....	31
REPLACING V-BELTS.....	31-32
PLATEN GRAPHITE .....	33
AIR SYSTEM.....	33
REPLACING BRAKES .....	34
SERVICE LOG .....	35
<b>9. CLOSURE</b> .....	36
<b>DATA SHEET</b> .....	37
<b>AIR SYSTEM</b> .....	38
<b>WIRING DIAGRAM</b> .....	39-41
<b>PARTS BREAKDOWN</b> .....	42-51
<b>TROUBLESHOOTING</b> .....	52-53
<b>WARRANTY AND RETURNS</b> .....	54

# SECTION 1: SAFETY

## **WARNING**

### **For Your Own Safety Read Instruction Manual Before Operating This Equipment**

The purpose of safety symbols is to attract your attention to possible hazardous conditions. This manual uses a series of symbols and signal words which are intended to convey the level of importance of the safety messages. The progression of symbols is described below. Remember that safety messages by themselves do not eliminate danger and are not a substitute for proper accident prevention measures.



Indicates an imminently hazardous situation which, if not avoided, WILL result in death or serious injury.



Indicates a potentially hazardous situation which, if not avoided, COULD result in death or serious injury.



Indicates a potentially hazardous situation which, if not avoided, MAY result in minor or moderate injury. It may also be used to alert against unsafe practices.

## **NOTICE**

This symbol is used to alert the user to useful information about proper operation of the equipment.

## **WARNING**

### **Safety Instructions For Power Tools**

- KEEP GUARDS IN PLACE** and in working order.
- REMOVE ADJUSTING KEYS AND WRENCHES.** Form habit of checking to see that keys and adjusting wrenches are removed from tool before turning on.
- KEEP WORK AREA CLEAN.** Cluttered areas and benches invite accidents.
- NEVER USE IN DANGEROUS ENVIRONMENT.** Do not use power tools in damp or wet locations, or where any flammable or noxious fumes may exist. Keep work area well lighted.
- KEEP CHILDREN AND VISITORS AWAY.** All children and visitors should be kept at a safe distance from work area.
- MAKE WORKSHOP CHILD PROOF** with padlocks, master switches, or by removing starter keys.
- NEVER FORCE TOOL.** It will do the job better and safer at the rate for which it was designed.
- USE RIGHT TOOL.** Do not force tool or attachment to do a job for which it was not designed.

# ⚠ WARNING

## Safety Instructions For Power Tools

9. **USE PROPER EXTENSION CORD.** Make sure your extension cord is in good condition. Conductor size should be in accordance with the chart below. The amperage rating should be listed on the motor or tool nameplate. An undersized cord will cause a drop in line voltage resulting in loss of power and overheating. Your extension cord must also contain a ground wire and plug pin. Always repair or replace extension cords if they become damaged.

Minimum Gauge for Extension Cords

AMP RATING	LENGTH		
	25ft	50ft	100ft
0-6	18	16	16
7-10	18	16	14
11-12	16	16	14
13-16	14	12	12
17-20	12	12	10
21-30	10	10	No

10. **WEAR PROPER APPAREL.** Do not wear loose clothing, gloves, neckties, rings, bracelets, or other jewelry which may get caught in moving parts. Non-slip footwear is recommended. Wear protective hair covering to contain long hair.
11. **ALWAYS USE SAFETY GLASSES.** Also use face or dust mask if cutting operation is dusty. Everyday eyeglasses only have impact resistant lenses, they are NOT safety glasses.
12. **SECURE WORK.** Use clamps or a vise to hold work when practical. It's safer than using your hand and frees both hands to operate tool.
13. **NEVER OVERREACH.** Keep proper footing and balance at all times.

14. **MAINTAIN TOOLS WITH CARE.** Keep tools sharp and clean for best and safest performance. Follow instructions for lubricating and changing accessories.
15. **DISCONNECT TOOLS** before servicing and changing accessories, such as blades, bits, cutters, and the like.
16. **REDUCE THE RISK OF UNINTENTIONAL STARTING.** Make sure switch is in off position before plugging in. Also, the magnetic switch on this machine may start if the switch gets bumped hard enough.
17. **USE RECOMMENDED ACCESSORIES.** Consult the owner's manual for recommended accessories. The use of improper accessories may cause risk of injury.
18. **CHECK DAMAGED PARTS.** Before further use of the tool, a guard or other part that is damaged should be carefully checked to determine that it will operate properly and perform its intended function. Check for alignment of moving parts, binding of moving parts, breakage of parts, mounting, and any other conditions that may affect its operation. A guard or other part that is damaged should be properly repaired or replaced.
19. **NEVER LEAVE TOOL RUNNING UNATTENDED. TURN POWER OFF.** Do not leave tool until it comes to a complete stop.
20. **NEVER USE UNDER THE INFLUENCE** of alcohol or drugs, or when tired.
21. **NEVER ALLOW UNSUPERVISED OR UNTRAINED PERSONNEL TO OPERATE THE MACHINE.** Make sure any instructions you give in regards to the operation of the machine are approved, correct, safe, and clearly understood.

## **WARNING**

# Additional Safety Instructions For The Wide-Belt Sander

- **DO NOT** allow anyone to stand at the out-feed end when feeding your stock.
- **DO NOT** jam workpiece into the machine during operation. Firmly grasp the workpiece in both hands and ease it into the machine using light pressure.
- **DO NOT** wear loose clothing while operating this machine. Roll up or button sleeves at the cuff.
- **DO NOT** sand any stock thinner than 1/8". **DO NOT** sand stock shorter than 9"
- **DO NOT** attempt to sand thin stock by using a "dummy" board under your workpiece.
- **DO NOT** place hands near, or in contact with, sanding belts during operation.
- **DO NOT** allow fingers to get pinched between board and conveyor belt during operation. This may pull the operator's hand into the machine and cause serious injury or death!
- **ALWAYS WEAR A DUST MASK** in addition to using a dust collector. This machine produces wood dust that may cause allergic reactions or respiratory problems.
- **NEVER** leave the machine running unattended.
- **NEVER** operate the sander without an adequate dust collection system in place and operating correctly.
- **NEVER** operate sander with the access doors open.
- **ANY PROBLEM**, with the exception of conveyor belt tracking, that is concerned at all with any moving parts or accessories must be investigated and corrected with the power disconnected and after all moving parts have come to a complete stop. Never attempt to adjust conveyor belt tracking when the sanding belts are engaged.
- **REPLACE** sanding belt when it becomes worn.
- **ALWAYS** inspect board stock for nails, staples, knots, and other imperfections that could be dislodged and thrown from the machine during sanding operations.
- **MAKE SURE** all operators have read and understand this manual before allowing them to use the sander. This includes employees, students and family!

## **WARNING**

As with all power tools, there is danger associated with Wide-Belt Sanders. Accidents are frequently caused by lack of familiarity or failure to pay attention. Use this tool with respect and caution to lessen the possibility of operator injury. If normal safety precautions are overlooked or ignored, serious personal injury may occur.

## **WARNING**

Operating this equipment has the potential for creating flying debris which can cause eye injury. Always wear safety glasses or goggles when operating equipment. Everyday glasses or reading glasses only have impact resistant lenses, they are not safety glasses. Be certain the safety glasses you wear meet the appropriate standards of the American National Standards Institute (ANSI).

# SECTION 2: INTRODUCTION

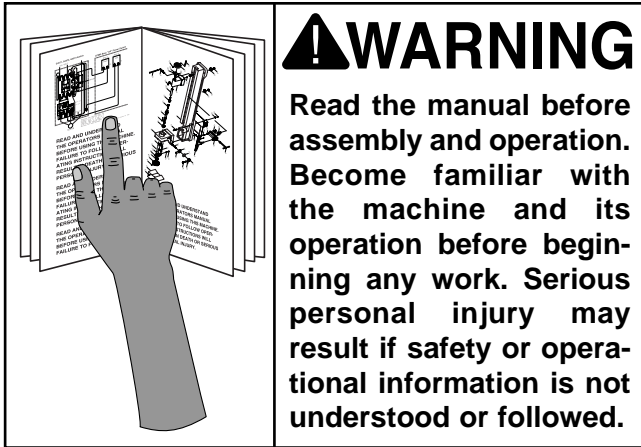

## **! WARNING**

**Read the manual before assembly and operation. Become familiar with the machine and its operation before beginning any work. Serious personal injury may result if safety or operational information is not understood or followed.**

We are proud to offer the Grizzly Model G9983 Wide-belt Sander. Your machine is part of a growing Grizzly family of fine woodworking machinery. When used according to the guidelines set forth in this manual, you can expect years of trouble-free, enjoyable operation and proof of Grizzly's commitment to customer satisfaction.

With its 15" open end, the Model G9983 has the capability to sand a 30" wide workpiece in two passes. This machine also features a 5 HP sanding belt motor and a ¼ HP feed motor, independent conveyor and sanding belt motor control, pneumatic belt tensioning and tracking, two rubber rollers, a load meter, a safety shut-off bar, and a 5" dust port.

We are also pleased to provide this manual with the Model G9983. It was written to guide you through assembly, review safety considerations, and cover general operating procedures. It represents our effort to produce the best documentation possible. If you have any comments regarding this manual, please write to us at the address below:

Grizzly Industrial, Inc.  
c/o Technical Documentation  
P.O. Box 2069  
Bellingham, WA 98227-2069

Most important, we stand behind our machines. If you have any service questions or parts requests, please call or write us at the location listed below.

Grizzly Industrial, Inc.  
1203 Lycoming Mall Circle  
Muncy, PA 17756  
Phone: (570) 546-9663  
Fax: (800) 438-5901  
E-Mail: [techsupport@grizzly.com](mailto:techsupport@grizzly.com)  
Web Site: <http://www.grizzly.com>

The specifications, drawings, and photographs illustrated in this manual represent the Model G9983 as supplied when the manual was prepared. However, owing to Grizzly's policy of continuous improvement, changes may be made at any time with no obligation on the part of Grizzly. For your convenience, we always keep current Grizzly manuals available on our website at [www.grizzly.com](http://www.grizzly.com). Any updates to your machine will be reflected in these manuals as soon as they are complete.

# SECTION 3: CIRCUIT REQUIREMENTS

## 220V Single-Phase

The Model G9983 features a 5 HP, 220V single-phase motor. This motor will safely draw about 30 amps under load. The Model G9983 also features a ¼ HP feed motor that draws approximately 1.8 amps under load. Total amperage draw for this machine is approximately 32 amps under load.

Use a 35 amp circuit breaker for the Model G9983. Make sure the wiring in your circuit is rated to handle the amperage draw from your machine. If frequent circuit failure occurs when using the sander, contact our Service Department. The sander must be connected to its own dedicated circuit and should not share a circuit with any other machine. A standard 2-pole breaker is necessary for use with the sander.

We recommend using a NEMA-style 6-50 plug and outlet (similar to the one shown in **Figure 1**) for the Model G9983. You may also “hard-wire” the sander directly to your panel, provided you place a disconnect near the machine. Check the electrical codes in your area for specifics on wiring requirements.

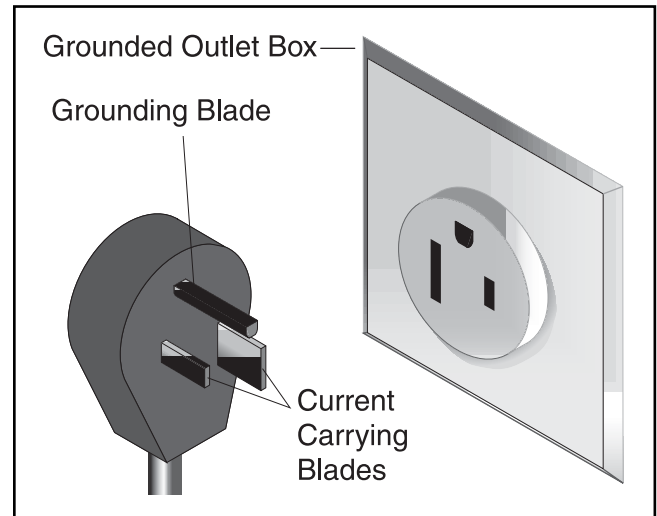
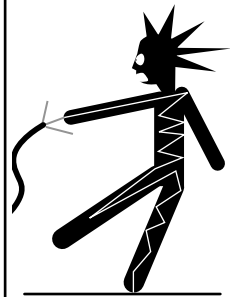

**Figure 1.** Plug configuration for 220V, single-phase 6-50 plug and outlet.





# Grounding

	<p><b>⚠ WARNING</b></p> <p>This equipment must be grounded. Verify that any existing electrical outlet and circuit you intend to plug into is actually grounded. Under no circumstances should the grounding pin from any three-pronged plug be removed. Serious injury may occur.</p>
---	--

In the event of an electrical short, grounding reduces the risk of electric shock by providing a path of least resistance to disperse electric current. This tool is equipped with an electric cord that has an equipment-grounding conductor which must be properly connected to a grounding plug. The plug must be plugged into a matching outlet that is properly installed and grounded in accordance with all local codes and ordinances.

Improper connections of the electrical-grounding conductor can result in the risk of electric shock. The conductor with green or green and yellow striped insulation is the electrical-grounding conductor. If repair or replacement of the electric cord or plug is necessary, do not connect the equipment grounding conductor to a live terminal.



# Extension Cords

We do not recommend the use of extension cords on 220V equipment. It is much better to arrange the placement of your equipment and the installed wiring to eliminate the need for extension cords.



# Wiring

The Model G9983 comes prewired for 220 volt operation. Wiring diagrams are provided at the back of this manual should it be necessary to repair or revise the wiring. Always consult a qualified electrician when doing any electrical work on this equipment.



## ⚠ CAUTION

**We have covered some basic electrical requirements for the safe operation of your Sander. These requirements are not necessarily comprehensive. You must be sure that your particular electrical configuration complies with local and state codes. Ensure compliance by checking with your local municipality or a licensed electrician.**

# SECTION 4: MACHINE FEATURES

## External Features

To help you understand the set up and operation instructions, we recommend that you become familiar with the basic features of your new sander.

Please match up the list below with the letters in **Figure 2** to identify the external sander components.

- A. Control Panel
- B. Table Extension
- C. Conveyor Height Handwheel
- D. Conveyor Height Gauge
- E. Dust Port
- F. Load Meter
- G. Emergency Stop Bar
- H. Pressure Regulator

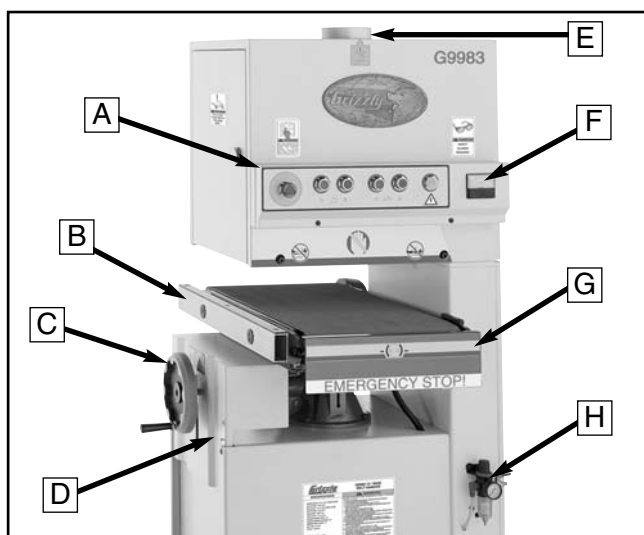
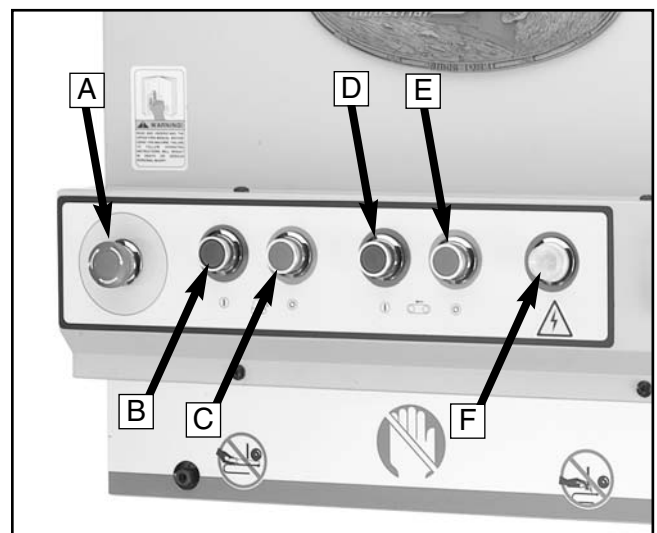

**Figure 2.** These are the basic external components of the sander.

## Control Panel

The control panel houses the main power switch, the feed belt *ON/OFF* buttons and the sanding belt *ON/OFF* buttons. Please refer to **Figure 3** to identify these controls.

- A. Main Power *ON* / Emergency *STOP* switch.
- B. Sanding Belt *OFF* button.
- C. Sanding Belt *ON* button.
- D. Feed Belt *OFF* button.
- E. Feed Belt *ON* button.
- F. Power Indicator Light



**Figure 3.** These are the main power controls.



# Access Doors

There are access doors located on each side of the sander. Throughout the manual, we refer to these doors as the “left-hand access door” and the “right-hand access door.” These terms are referenced as if you are facing the front of the machine.

**Figure 4** shows the layout behind the left-hand access door.

- A. Limit Switch
- B. Sanding Belt Tension Switch
- C. Platen Adjustment Knob

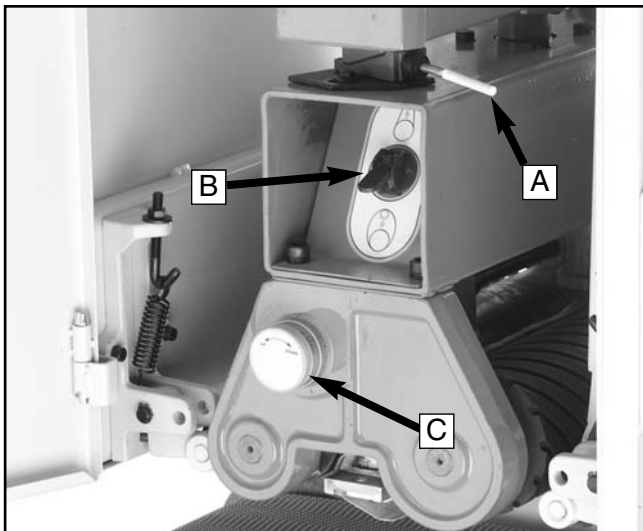

**Figure 4.** These items are behind the left-hand access door.

**Figure 5** shows the layout behind the right-hand access door.

- A. Oscillating Roller
- B. Oscillation Air Filter
- C. Limit Switch
- D. Oscillation Return Valve
- E. Oscillation Speed Valve
- F. Oscillation Timing Knob

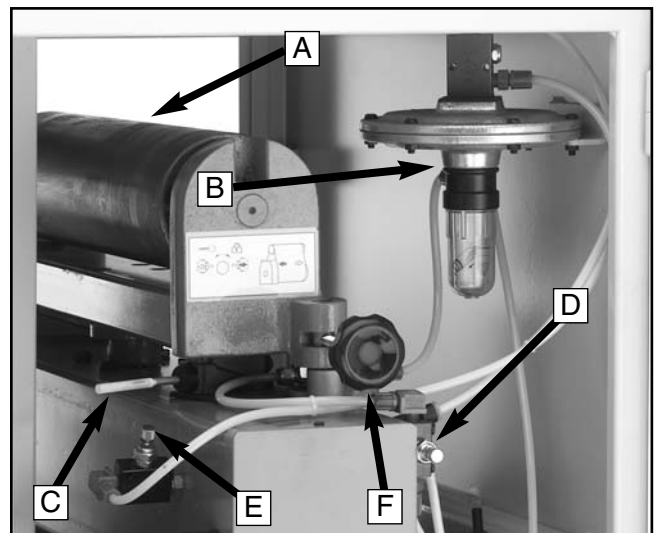

**Figure 5.** These items are behind the right-hand access door.



# SECTION 5: SET UP

## Unpacking

The Model G9983 Wide-belt Sander is shipped from the manufacturer in a carefully packed carton. If you discover your machine is damaged after you have signed for delivery, and the truck and driver are gone, you will need to file a freight claim with the carrier. Save the containers and all packing materials for possible inspection by the carrier or its agent. Without the packing materials, filing a freight claim can be difficult. *If you need assistance determining whether you need to file a freight claim, or with the procedure to file one, please contact our Customer Service.*

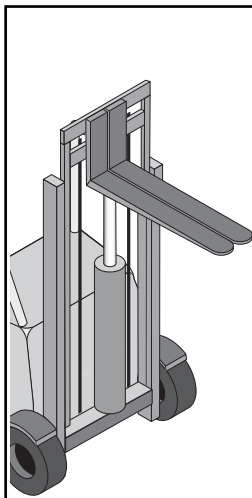

### **⚠️ WARNING**

The Model G9983 is a heavy machine—approx. 1000 lb. **DO NOT over-exert yourself while unpacking or moving your machine. You will need assistance and power equipment. Serious personal injury may occur if safe moving methods are not followed.**

When you are completely satisfied with the condition of your shipment, you should inventory its parts.



### **NOTICE**

A full parts list and breakdown can be found toward the end of this manual. For easier assembly, or to identify missing parts, please refer to the detailed illustrations at the end of the manual.

## Piece Inventory

After all the parts have been removed from the carton, you should have:

- Sanding Unit
- Tool Box
- Combo Wrench 8/10MM
- Combo Wrench 11/13MM
- Combo Wrench 12/14MM
- Combo Wrench 17/19MM
- Combo Box-Wrench 30/37MM
- Phillips Screwdriver
- Hex Wrench Set
- Platen Puller
- Platen
- Door Handle (2)
- Handwheel Handle
- Sanding Belt #180
- Sanding Belt #240

In the event that any non-proprietary parts are missing (e.g. a nut or a washer), we would be glad to replace them, or for the sake of expediency, replacements can be obtained at your local hardware store. Loose parts in the sander crate (not including hardware) are shown in **Figure 6**.

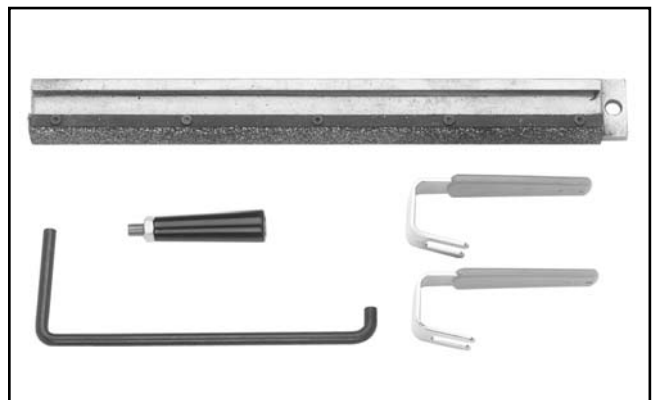

**Figure 6.** Loose parts (not including hardware) for the Model G9983.



# Hardware Recognition Chart

Use this chart to match up hardware pieces during the assembly process!

MEASURE BOLT DIAMETER BY PLACING INSIDE CIRCLE

- #10
- 1/4"
- 5/16"
- 3/8"
- 7/16"
- 1/2"
- 5/8"
- 4mm
- 6mm
- 8mm
- 10mm
- 12mm
- 16mm

LINES ARE 1MM APART

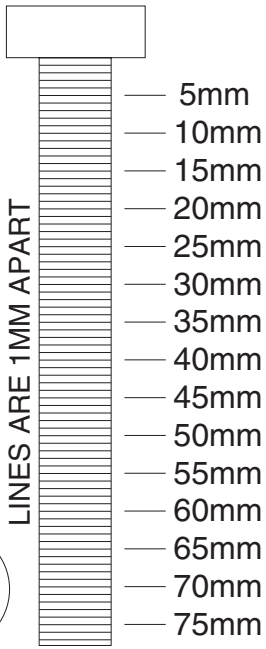

LINES ARE 1/16" INCH APART

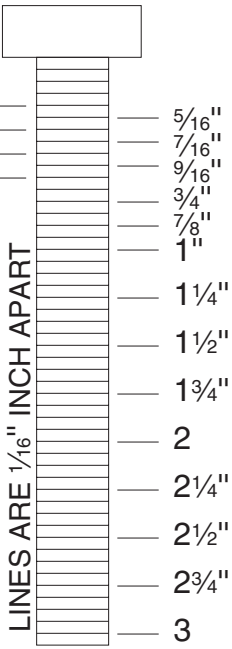

Lock Nut  
Wing Nut  
Thumb Screw  
Phillips Head Screw  
Countersunk Phillips Head Screw  
Slotted Screw  
Cap Screw  
Carriage Bolt  
Flange Bolt  
Button Head Screw  
Setscrew  
Hex Head Bolt  
Phillips Head Hex Bolt  
Phillips Head Sheet Metal Screw  
Washer  
Lock Washer  
Hex Nut

WASHER DIAMETER 5/8"  
WASHER DIAMETER 9/16"  
WASHER DIAMETER 1/2"  
WASHER DIAMETER 7/16"  
WASHER DIAMETER 12mm  
WASHER DIAMETER 7/16"  
WASHER DIAMETER 3/8"  
WASHER DIAMETER 10mm  
WASHER DIAMETER 4mm  
WASHER DIAMETER 5/16"  
WASHER DIAMETER 6mm  
WASHER DIAMETER 8mm  
WASHER DIAMETER 1/4"  
WASHER DIAMETER 10mm  
WASHER DIAMETER 12mm  
WASHER DIAMETER 16mm  
#10

WASHERS ARE MEASURED BY THE INSIDE DIAMETER

# Clean Up

The unpainted surfaces are coated with a waxy oil to protect them from corrosion during shipment. Remove this protective coating with a solvent cleaner or citrus-based degreaser such as Grizzly's G7895 Degreaser. To clean thoroughly, some parts may need to be removed. **For optimum performance from your machine, make sure you clean all moving parts or sliding contact surfaces that are coated.** Avoid chlorine-based solvents as they may damage painted surfaces should they come in contact. Always follow the manufacturer's instructions when using any type of cleaning product.



## **⚠️ WARNING**

**Do not use gasoline or other petroleum-based solvents to clean with. They have low flash points which make them extremely flammable. A risk of explosion and burning exists if these products are used.**



## **⚠️ WARNING**

**Do not smoke while using solvents. A risk of explosion or fire exists and may result in serious personal injury.**

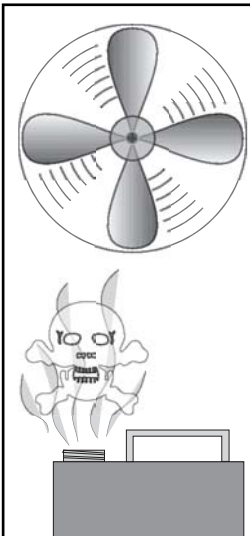

## **⚠️ CAUTION**

**Many of the solvents commonly used to clean machinery can be toxic when inhaled or ingested. Always work in well-ventilated areas far from potential ignition sources when dealing with solvents. Use care when disposing of waste rags and towels to be sure they do not create fire or environmental hazards.**

# Site Considerations

## FLOOR LOAD

Your new wide-belt sander represents a large weight load in a moderate sized footprint. Most shop floors will be adequate for the weight of the wide-belt sander; however, some floors may require additional support. Contact an architect or structural engineer if you have any question about the ability of your floor to handle the weight.

## WORKING CLEARANCES

Working clearances can be thought of as the distances between machines and obstacles that allow safe operation of every machine without limitation. Consider existing and anticipated machine needs, size of material to be processed through each machine, and space for auxiliary stands and/or work tables. Also consider the relative position of each machine to one another for efficient material handling. Be sure to allow yourself sufficient room to safely run your machines in any foreseeable operation.

## LIGHTING AND OUTLETS

Lighting should be bright enough to eliminate shadow and prevent eye strain. Electrical circuits should be dedicated or large enough to handle combined motor amp loads. Outlets should be located near each machine so power or extension cords are not obstructing high-traffic areas. Be sure to observe local electrical codes for proper installation of new lighting, outlets or circuits.

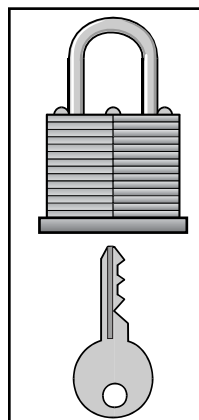

## **⚠️ CAUTION**

**Make your shop "child safe." Ensure that your workplace is inaccessible to children by closing and locking all entrances when you are away. Never allow visitors in your shop when assembling, adjusting or operating equipment.**



# Beginning Assembly

Most of your new wide-belt sander has been assembled at the factory, but some setup is required after delivery. We have organized the setup process into steps. Please make sure the sander is placed in its final position in your shop and follow along in the order presented in this section.

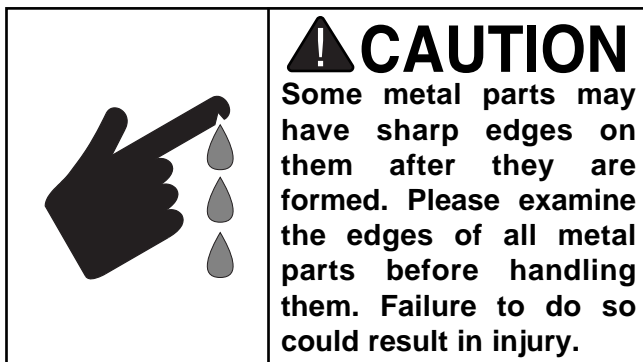
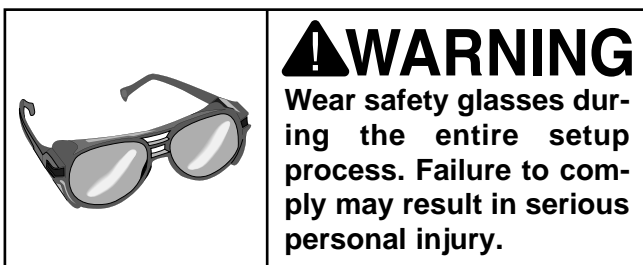
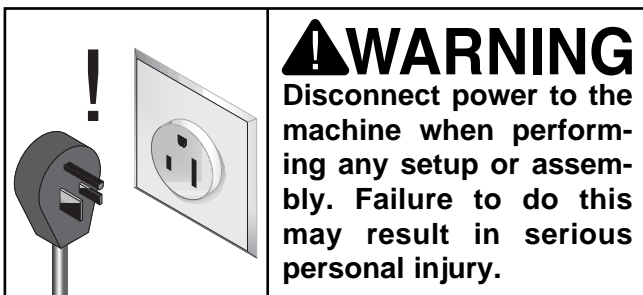
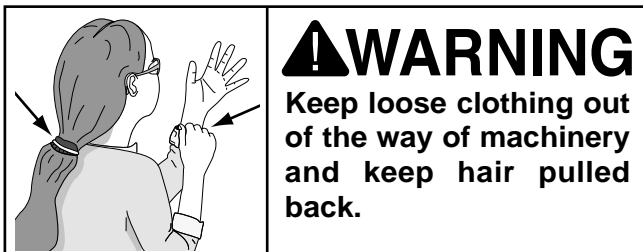

# Handwheel Handle

To install the handwheel handle:

1. Thread the handle into the handwheel as shown in **Figure 7**.
2. After handle is completely threaded down, tighten the jamnut so the handle will not come loose. Make sure to leave the plastic sleeve loose enough to rotate when you crank the handwheel.



Figure 7. Install handle onto handwheel.

## NOTICE

The waxy grease must be completely cleaned from the table column for smooth table height adjustments.



# Platen

---

---

The housing for the platen can be accessed by opening the door on the left-hand side of the machine.

A graphite sheet is mounted on the platen. Before installing, make sure that the graphite sheet is mounted on the left-hand side of the platen, as it will be inserted. **Figure 8** shows the platen being installed correctly.

The direction of the graphite sheet is important because it must wrap around the platen in the same direction as the sanding belt rotates. If not, the sanding belt will unwrap the graphite sheet, exposing the sanding belt to the metal body of the platen. *Note: the graphite sheet on the platen is considered a "consumable" item, similar to the sanding belts, and normal wear and tear from machine operation is not covered under warranty. For additional information on the platen, turn to page 33.*

## To insert the platen:

1. Line up the platen dovetail with the housing so it is positioned as described above.
2. Slide the platen into the housing as far as it can go.

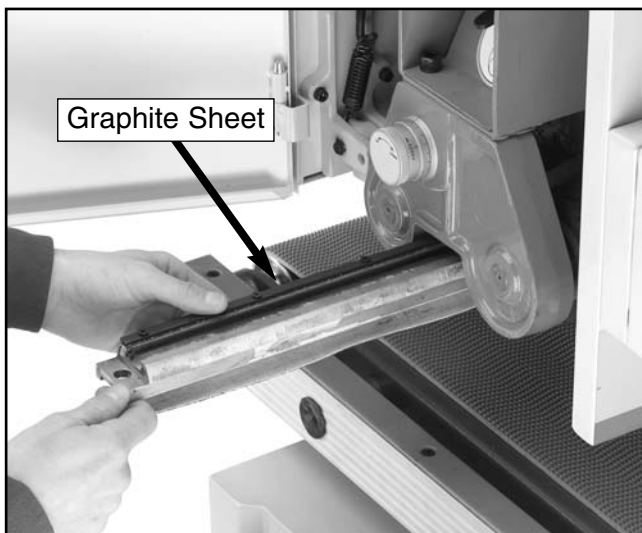

**Figure 8.** Install the platen with the graphite sheet on the left-hand side.

The platen must now be set even with the sanding rollers.

## To set the platen even with the belt rollers:

1. Lower the conveyor table as far as it will go.
2. Open the access door on the left-hand side and locate the platen adjustment knob shown in **Figure 9**.



**Figure 9.** Use this knob to raise/lower the platen.

3. Place a straightedge across both lower belt rollers and rotate the adjustment knob until the platen barely touches the straightedge. *The platen should now be set even with the belt rollers.*





---

---

# Air Hose

The air hose connection is located at the regulator on the front of the machine.

## To connect the air hose:

1. Fit the hose over the regulator nozzle.
2. Secure the hose with a hose clamp as shown in **Figure 10** and turn on your air compressor.
3. **Regulate the air pressure to 75 PSI.** This is the normal operating pressure for the Model G9983.



**Figure 10.** Secure air hose with a hose clamp.

## NOTICE

**DO NOT** exceed 75 lb. of air pressure. Damage to the machine components may result.

## NOTICE

The main shut off valve should remain closed until air pressure is needed. This will reduce wear and tear on the air system components.



---

---

# Sanding Belt

The Model G9983 is designed for 16" x 48" sanding belts.

## To install a sanding belt:

1. Open the left-hand side door for access.
2. Make sure the greasy protective coating has been cleaned from the metal belt roller before installing sanding belt.
3. Fit the sanding belt completely over the three sanding rollers as shown in **Figure 11**. *The belt will move counter-clockwise during rotation—make sure that the arrows on the inside of the belt point in the direction of rotation.*



**Figure 11.** Place belt over the three belt rollers to install. Make sure arrows on inside of belt point in the direction of rotation.



# Sanding Belt Tension

The sanding belt tension is controlled by a switch located inside the upper portion of the machine (see **Figure 12**). To locate it, open the access door on the left-hand side of the sander.



**Figure 12.** This is the belt tension switch.

## To Tighten Belt Tension:

Flip the switch up. The vertical cylinder will automatically tighten the top roller to the correct tension.

## To Loosen Belt Tension:

Flip the switch down. The vertical cylinder will automatically loosen the belt tension for belt removal.

## NOTICE

The belt tension switch is part of the air control system. This means the machine must have air pressure for the switch to work correctly.

## NOTICE

Always tighten belt before starting sander!



# Pressure Rollers

## ⚠️ WARNING

Always keep the pressure rollers set below the level of the sanding roller. If the pressure rollers are even, or higher than the sanding roller, the wood **WILL** be propelled from the sander at a high rate of speed. This situation could cause serious personal injury.

The pressure rollers have been set at the factory, but for increased personal safety, you should verify that they are below the sanding belt.

## To check the feed pressure:

1. **Disconnect the sander from the power source!**
2. Place a piece of scrap wood of uniform thickness across the conveyor so it spans both front and rear pressure rollers at the same time.
3. Make sure the platen is even with the sanding belt rollers.
4. With the air pressure connected, the sanding belt installed, and the belt tension switch *ON*, slowly raise the conveyor and verify that the board touches both pressure rollers before it touches the sanding belt.

If the board does not touch both pressure rollers before it touches the sanding belt, then the pressure rollers must be adjusted before operation. See *Section 8: Service Adjustments* for step-by-step instructions on how to do this.



# Dust Collection

## CAUTION

**DO NOT** operate the Model G9983 without an adequate dust collection system. This machine creates substantial amounts of wood dust while in operation. Failure to use a dust collection system may result in short and long-term respiratory illness.

The dust collection port is located on top of the sander and measures 5" in diameter. It will be necessary to attach a 5" dust collection pipe over this port before operation. If you have rigid ducts in your dust collection system, we recommend that you connect the ducts to your sander with flexible hose. The flex-hose easily attaches with a 5" hose clamp and it absorbs any movement that may occur during operation. Please refer to the Grizzly catalog for current price and ordering information.

**Your dust collector must be able to move 800-1200 CFM at the Wide-belt Sander.** If you have a remotely located dust collector, or if you are operating more than one machine at a time, ensure that your dust collector has the capacity and power to meet this requirement. A fine layer of dust may be present on your stock as it comes out of the sander. This is normal.

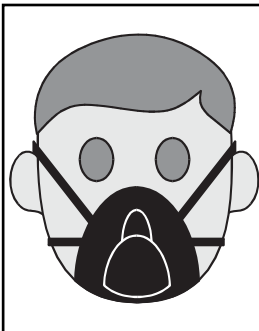

## CAUTION

Always wear a dust mask in addition to using a dust collector. Dust masks filter out the smaller particles of dust that dust collectors cannot trap.



# Test Run

Once the assembly is complete and the adjustments are done to your satisfaction, you are ready to test run the sander.

## Before you test run your machine:

1. Read back through *Section 1: Safety Instructions*, *Section 4: Assembly*, and the previous instructions in this section to make sure that all precautions have been taken for safe operation.
2. Make sure the machine is connected to an air compressor and the pressure gauge on the sander reads 75 PSI.
3. Make sure that any tools or foreign objects have been removed from the machine.
4. Last but not least, make sure the wiring is correct. Did you follow the instructions from *Section 2: Circuit Requirements*? If you are not confident with the wiring, go back and double check that all precautions have been taken to ensure safety to the operator and the circuit. When you are confident, connect the machine to the power source. The power indication light on the control panel should light up.

## WARNING

**DO NOT** attempt to investigate or adjust any features of the machine while it is running. Wait until the machine is turned off, unplugged and all working parts have come to a rest before you do anything! Failure to do so could result in severe personal injury.

## To test run the sander:

1. Turn on the power supply at the main panel.

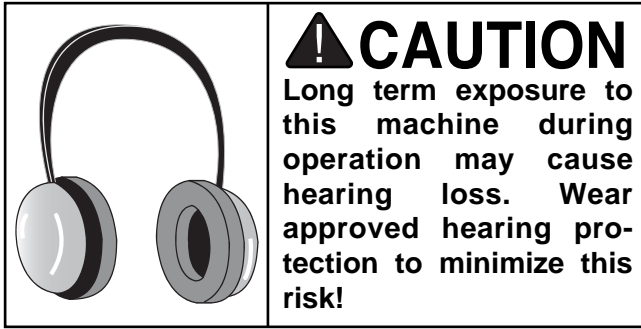

2. Start both the sanding belt and the feed belt, making sure your finger is poised over the *STOP* button, just in case there is a problem. The wide-belt sander should run smoothly, with little or no vibration or abnormal rubbing noises. It is normal, however, for the air operated tracking to make a rhythmic back and forth noise.

Strange or unnatural noises should be investigated and corrected before operating the machine further. To avoid injury or damage to the machine, **DO NOT** attempt to make adjustments to the machine without turning it off and unplugging it from its power source.

If noises occur that cannot be found by visual inspection, feel free to contact our Service Department for help.



## Recommended Adjustments

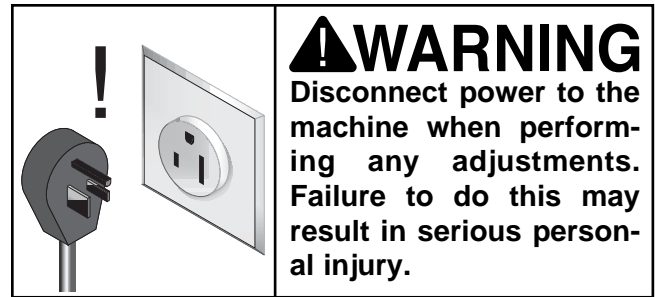

For your convenience, the adjustments listed below have been performed at the factory and no further setup is required to operate your machine.

However, because of the many variables involved with shipping, we recommend that you at least check the following adjustments to ensure the best possible results from your new machine.

All of these adjustments are covered in step-by-step detail in *Section 8: Service Adjustments*.

### Recommended adjustment checklist:

- Pressure Rollers
- Oscillation Timing
- Oscillation Speed
- Oscillation Return
- Limit Switch Position
- Feed Belt Tension
- Feed Belt Tracking
- V-Belt Tension



# SECTION 6: OPERATIONS

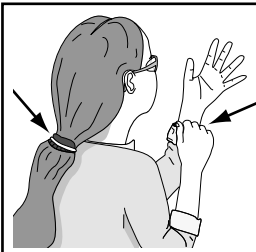

## **⚠️ WARNING**

Keep loose clothing out of the way of machinery and keep hair pulled back during operations.



## **⚠️ WARNING**

Disconnect power to the machine when performing any maintenance or adjustments. Failure to do this may result in serious personal injury.



## **⚠️ WARNING**

Wear safety glasses during the entire operation process. Failure to comply may result in serious personal injury.

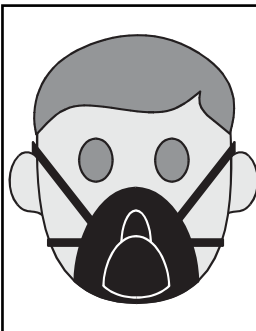

## **⚠️ CAUTION**

Always wear a dust mask in addition to using a dust collector. Dust masks filter out the smaller particles of dust that dust collectors cannot trap.

## **NOTICE**

The following section was designed to give instructions on the basic operations of this wide-belt sander. However, it is in no way comprehensive of every wide-belt sander application. **WE STRONGLY RECOMMEND** that you read books, trade magazines, or get formal training to maximize the potential of your wide-belt sander.

## Before Starting

Before beginning any work with your machine, make sure you have read through this entire manual. Your safety while running this machine absolutely depends on your familiarity and compliance with the information in this manual.



## Choosing Sandpaper

The Model G9983 takes 16"W x 48"L sanding belts.

The grit you choose will depend on the type of work, the species of wood and the stage of finishing. Below is a chart that groups abrasives into different classes and shows which grits fall into each class. We recommend using aluminum oxide for best results.

Grit	Type
60	Coarse
80-100	Medium
120-150	Fine

The general rule of thumb is to sand a workpiece with progressively higher grit numbers, with no one grit increase of more than 50.

Ultimately, the type of wood you use and your stage of finish will determine the best grit types to install on your sander.



# Conveyor Height

Conveyor height is controlled by turning the handwheel shown in **Figure 13**. A scale is located near the handwheel for gauging conveyor movement. The scale is marked in millimeters and inches. **Figure 14** demonstrates how the handwheel movement affects the conveyor.

After you have moved the conveyor to the desired height, lock it in place with the conveyor lock handle shown in **Figure 13**.

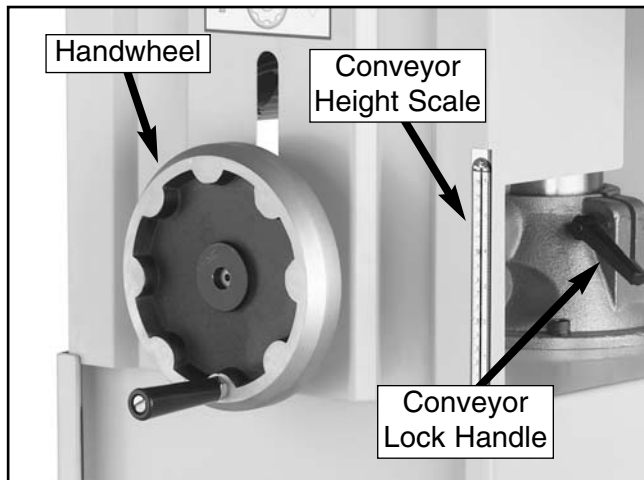

**Figure 13.** The handwheel moves the conveyor and the scale tells you how far the conveyor moved.

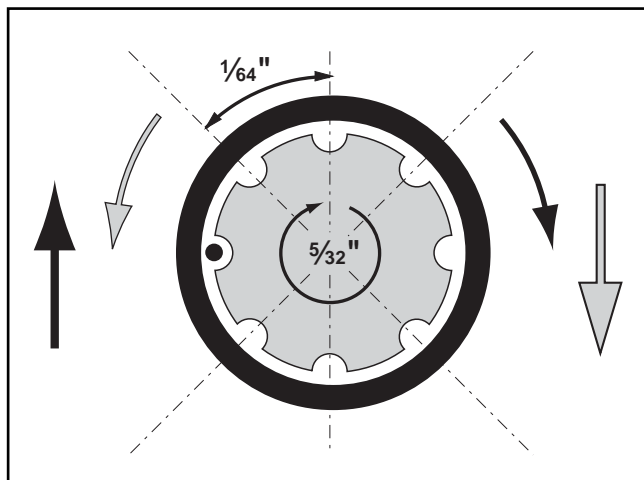
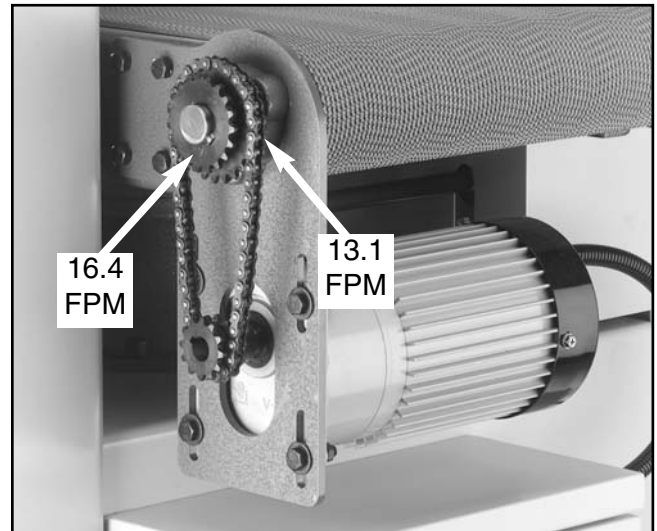

**Figure 14.** This illustration shows how the handwheel moves the conveyor.



# Feed Belt Speed

The feed belt motor (shown in **Figure 15** with the cover removed) controls the speed of the feed belt. The Model G9983 features speeds of 13.1 FPM and 16.4 FPM.



**Figure 15.** This is the feed belt motor. Place the chain on either of the sprockets and the feed belt will travel at the speed shown.

## To change feed belt speeds:

1. **Unplug the sander!**
2. Remove the cap screw that secures the feed belt motor cover.
3. Loosen the four motor mount bolts so that the motor will slide up enough to get the chain off the sprockets.
4. Determine which speed is best for your application and place the chain on either set of the sprockets shown in **Figure 15**.
5. Replace the motor cover and secure it with the cap screw.



# Load Meter

The load meter shown in **Figure 16** displays the current amperage draw of the sanding belt motor. The needle rises when you increase the load on the sanding belts and decreases when you decrease the load. Use this meter to avoid overloading your machine with too heavy of a cut.

**NEVER exceed 30 amps—this is the maximum that your machine can safely handle!**

Since various types of stock will react differently to various loads, use trial-and-error to determine the best settings for your applications. As a general rule, always start with a small load and work your way up. **DO NOT** push your machine to its maximum load; instead, use multiple passes or install a coarser grit paper.



**Figure 16.** This is the load meter.

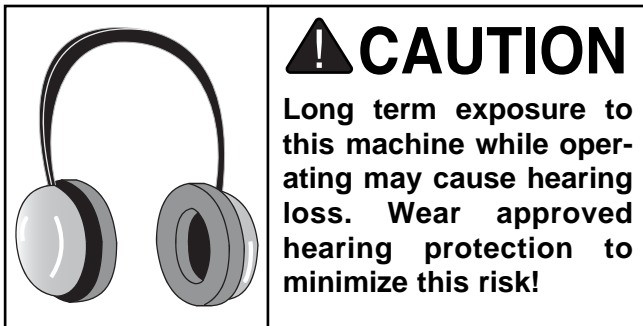

# Operation

Under most sanding conditions, a normal cut is no more than .5mm (approx. 1/64"). This depth can be achieved by 1/8th turn of the conveyor height handle. Attempts to remove too much can cause jamming, wood burning, rapid paper wear or tearing, poor finish and belt slippage. For each pass, turn the stock 180° to ensure an even cut.

## ⚠ CAUTION

**Make sure any stock that you run through the sander is clean and free of any defects or foreign materials that might damage the sanding or conveyor belt.**

## NOTICE

**We strongly recommend sending wide stock through the sander two or three times after the correct height has been established. This is an important step to prevent burning your wood or ruining sandpaper.**

**The following is the correct start-up and operating procedure:**

1. Start the dust collector.
2. Make the thickness adjustment by placing the workpiece on the conveyor table and turning the conveyor handle until the workpiece can be sanded and fed through smoothly. *Turning the handle clockwise will raise the conveyor table. Turning the conveyor handle counter-clockwise will lower the conveyor table.*
3. Remove the workpiece from the conveyor belt.
4. Start the sander and feed your stock. Retrieve by standing at the side—not at the outfeed end.



---

---

## Platen Depth

The platen position allows for 3 types of operation. These different positions can be adjusted by rotating the knob shown in **Figure 17**. Notice that the knob has a scale on it. By keeping track of how many revolutions you have rotated the knob, you can determine how far you have moved the platen.



**Figure 17.** The scale on this knob tells you how far you have moved the platen.

### The three basic platen positions:

**Platen Up** — The platen is raised above the level of the sanding rollers. This position allows the front roller to remove large amounts of material quickly, but leaves a rough finish. The best belt grit for this position is #100 or coarser.

**Platen Even** — The platen is set even with the sanding rollers. The rollers work together with the platen to produce intermediate/final finishing. The best belt grit for this position is #100-#180.

**Platen Down** — The platen is lowered below the sanding rollers. The majority of the work is accomplished by the platen pressure on the workpiece. The result is a smooth, flat finish. The best belt grit for this position is #180 or finer. *Avoid lowering the platen more than .2MM below the sanding belt rollers—this is the equivalent to 1 full turn of the knob.*



---

---

## Cleaning Pads

Cleaning Pads (one is shown in **Figure 18**) are the perfect way to enhance your wide-belt sanding operations. Simply set the conveyor table to height and feed the pad through to “unload” a used sanding belt. This cleaning will greatly increase the lifespan of your sanding belts. Since each pad can be used dozens of times, you will actually save money in the long run. Check with the current Grizzly catalog for more details.

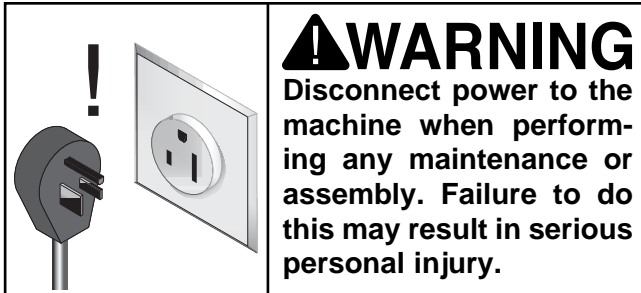

**Figure 18.** Sanding belt cleaning pad.





# SECTION 7: MAINTENANCE



## General

Make a habit of inspecting your Model G9983 each time you use it. **Failure to routinely inspect your wide-belt sander for damage and wear could result in unsatisfactory work results, premature component or machinery failure, or operator injury. We recommend you create a checklist for routine inspection and maintenance.** Check for the following conditions and repair or replace when necessary.

- Loose mounting bolts.
- Worn or damaged sanding belt.
- Worn or damaged cords, plugs or switch.
- Damaged V-belt.
- Any other condition that could hamper the safe operation of this machine.



## Lubrication

Roller bearing blocks must be lubricated every 20 hours of operation with high-quality, lithium based grease via grease fittings on top of each block.

Other moving parts, such as chains, should be lubricated periodically with a light machine oil. Do not use too much lubrication because excess can attract dirt and sawdust and will clog the chain mechanism.



## Cleaning Sanding Belts

You can greatly increase the lifespan of your sanding belts if you clean them often. As mentioned on **page 22**, cleaning pads are the best way to do this.

Whenever sanding belts decrease in performance because of heavy loading, feed the cleaning pad through the sander. Repeat this process until the sanding belts are clean again—this will ensure optimum performance.



## Emptying Filters

There are two filters on the Model G9983. The first filter is located under the main regulator that houses the pressure gauge. The second filter, shown in **Figure 19**, is located near the oscillation controls. Since the eye fork configuration is prone to collecting sawdust, check and empty this filter often.

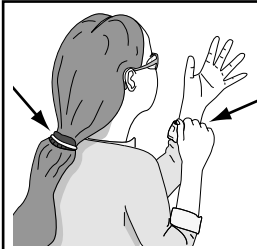

**Figure 19.** Unscrew this filter to empty it.





# SECTION 8: SERVICE ADJUSTMENTS



## **⚠️ WARNING**

Keep loose clothing out of the way of machinery and keep hair pulled back.

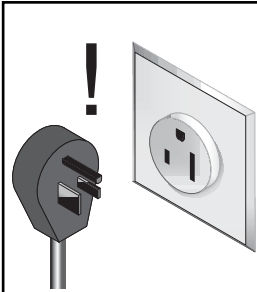

## **⚠️ WARNING**

Disconnect power to the machine when performing any maintenance or assembly. Failure to do this may result in serious personal injury.



## **⚠️ WARNING**

Wear safety glasses during the entire assembly process. Failure to comply may result in serious personal injury.

## Oscillation Timing

The first step in adjusting the oscillation is timing the side to side movement the belt makes when oscillating. The belt should take the same amount of time to travel to one side as it did the other.

## **⚠️ CAUTION**

Keep your hands clear of the sanding belt when making the adjustments in this step. The sandpaper is designed to remove a lot of material quickly whether it is wood or skin!

To time the oscillation movement:

1. Open both access doors to the upper part of the machine so you can view the belt movement. The sanding belt should also be on the rollers and tightened. Turn the sanding belt *ON*.
2. Count the amount of time it takes the belt to move from one side to the other. If the oscillation balance is correct, the belt will move from one side to the other in even intervals. If the balance is not correct, the belt may move to one side very quickly, then very slowly to the other.
3. If the belt immediately moves too far and shuts off the machine, then loosen the oscillation timing control knob shown in **Figure 20** and move it toward the front or rear of the machine to rotate the eccentric.
4. Loosen the belt tension, rebalance the sanding belt and retighten the belt tension. Repeat **steps 2 and 3**.

# Oscillation Speed



**Figure 20.** This is the oscillation timing control knob.

5. When you get the belt to oscillate without stopping, experiment with the timing knob to see the effect its movement has on the belt oscillation.
6. Position the timing knob so the belt moves from one side to the other, back and forth, in even intervals.
7. Lock the knob in place by turning it clockwise.

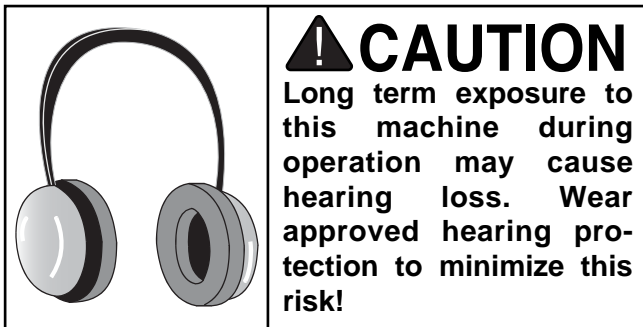

**Figure 21.** Use the knob on this valve to control oscillation speed.



**To increase the oscillation speed**, open the valve (turn the knob counter-clockwise). For normal operation, adjust the oscillation speed so each direction of belt movement takes approximately 2 seconds. When the speed is correct, tighten the jamnut so the knob will not move.

**To decrease the oscillation speed**, close the valve (turn the knob clockwise). When the speed is correct, tighten the jamnut.

Different speeds may yield different finishing results. Experiment with trial-and-error to determine the best speed for your particular situation.



# Oscillation Return

The oscillation return keeps the sanding belt in motion. The valve shown in **Figure 22** controls the oscillation return.

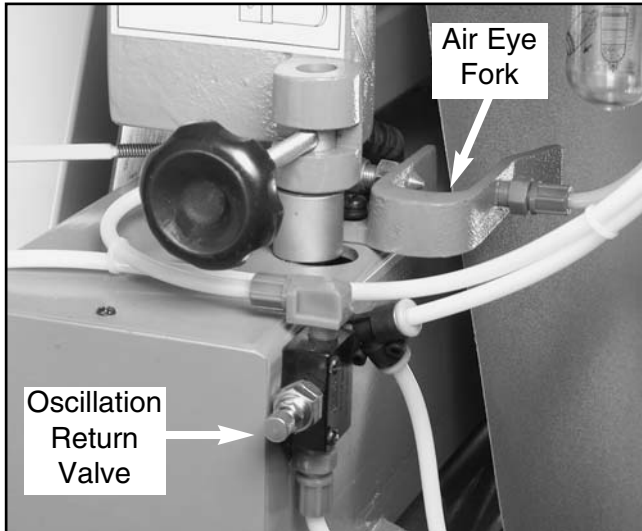

**Figure 22.** This is the oscillation return valve and the air eye fork.

## To adjust the oscillation return:

1. Turn off all power to the sander, but keep air pressure going into the machine. Lower the belt and slide it out of the way of the eye fork.
2. Block the airflow between the eye fork until the top roller rotates to one side and does not return.
3. With the airflow still blocked, loosen the jamnut on the valve knob and tighten the knob to close the valve.
4. Now clear the eye fork so the air will flow between it again. Watch the top roller and slowly open the valve.
5. When the top roller begins to move, open the valve another  $\frac{1}{4}$  to  $\frac{1}{2}$  turn of the knob. Tighten the jamnut. **DO NOT** open the valve more than needed or there will be excessive pressure on the air system.



# Limit Switches

The limit switches are mounted on both sides of the sanding belt. They are designed to stop the sander if the belt travels too far to one side of the top roller.

The limit switches are factory set and should require no adjustments. However, if they stop working correctly, they move during adjustments, or they get replaced, proper adjustments will be required.

## To adjust the limit switches:

1. Center the sanding belt on the top roller. Measure the distance between the edge of the sanding belt and the limit switch lever. This distance should be approximately  $\frac{1}{2}$ ". If this measurement is different, then loosen the adjustment bolts shown in **Figure 23** on the incorrect side.



**Figure 23.** Loosen these bolts to adjust the limit switch position.

2. Slide the mounting bracket in the necessary direction until there is a  $\frac{1}{2}$ " gap between the edge of the belt and the limit switch lever.
3. Tighten the adjustment bolts to secure the mounting bracket. Test the sander to verify that operation returns to normal.



# Pressure Roller Depth

---

---

Variables such as feed rate, depth of the cut, and type of sanding belt can play a big part in determining the proper amount of downward pressure exerted by the rollers. Some experimentation may be necessary with pressure roller spring tension to achieve the desired results. However, under no circumstances should the pressure roller depth be set even, or higher than, the sanding rollers or platen.

## To adjust the pressure roller depth:

### 1. Unplug the sander!

2. Joint and plane a 6" W x 36"L piece of wood, then rip it down the middle. This will give you two boards that are nearly the exact same thickness.
3. Place one board along the length of the conveyor belt on the right-hand side so it is directly beneath both front and back pressure roller depth bolts. Place the other board on the left-hand side so it is directly beneath both front and back pressure roller depth bolts. **Figure 24** shows the front left-hand and front right-hand pressure roller adjustment bolts.

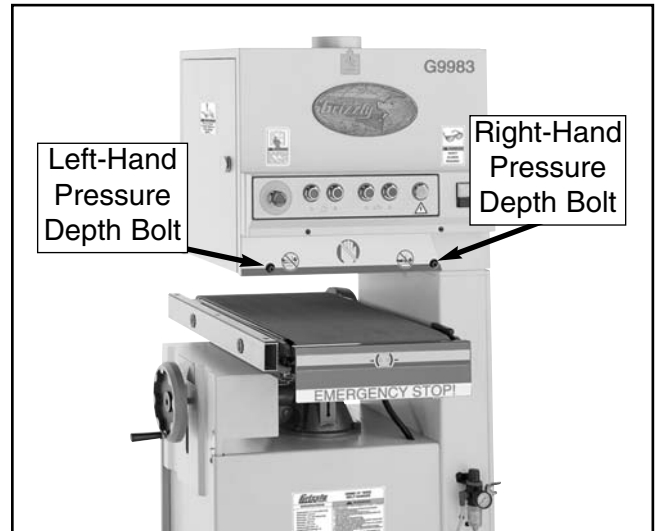

**Figure 24.** These are the pressure roller depth bolts at the front of the machine. *The rear depth bolts are in the same location at the rear.*

4. With the air pressure connected, and the sanding belt installed and tensioned, raise the pressure rollers above the sanding belt rollers.
5. Raise the conveyor until the the boards touch the sanding belt rollers. The rollers should evenly touch the boards at the same time.
6. Turn the conveyor handwheel counterclockwise  $\frac{1}{8}$ th of a turn. This should lower the conveyor approximately .020" or .5mm.
7. Lower each end of the pressure rollers so they barely touch the boards. Lock in place.



# Pressure Roller Tension

Pressure roller tension is largely set by trial and error. If there is not enough tension, the workpiece will not pass through the sander evenly and may possibly be launched toward the operator. If there is too much tension, the feed belt will experience premature wear and the workpiece will pass through the sander sluggishly (if at all).

## To adjust the pressure roller tension:

1. **Unplug the sander!**
2. Make sure the pressure roller depth is set correctly.
3. Open both access doors and locate the pressure roller tension springs shown in **Figure 25**.



**Figure 25.** This is one of the four pressure roller adjustment bolts.

4. Turning the nut on the adjustment bolt clockwise will increase the tension and counter-clockwise will decrease the tension.

A quick way to gauge that the spring tension is consistent is to measure the distance from the top of the nut to the top of the adjustment bolt. If the board pulls to one side during sanding, loosen that side in small increments as needed.



# Feed Belt Tension

---

---

To adjust the feed belt tension:

1. **Disconnect the sander from the power source!**
2. Move the emergency brake plate up and out of the way.
3. Tension adjustments are made using the bolts located on the left and right side of the front conveyor roller as shown in **Figure 26**.
4. When tensioned properly you should not be able to lift the belt off the conveyor surface or slide it back and forth, and it should not slip.
5. Perform the "Feed Belt Tracking" instructions to ensure that the tracking did not change during tensioning.



# Feed Belt Tracking

---

---

To check the feed belt tracking:

1. Turn the feed belt *ON*.
2. If the belt moves to one side then you need to immediately stop the machine and adjust the belt tracking. If the belt tracks evenly, leave it alone.

To adjust the feed belt tracking:

1. **Unplug the sander!**
2. Use the adjustment bolts (one is shown in **Figure 26**) to correct the tracking.
3. Run the feed belt for a few minutes after the adjustment to allow the belt to move into its new position. When you are satisfied that the belt has finished moving, stop the feed belt.
4. If more adjustments are necessary, experiment with how the movement of the adjustment bolts affects the belt tracking; do this until you can make the feed belt track evenly. Make sure you did not loosen the belt during the tracking process. If you did, adjust each side of one belt roller away from the machine, as evenly as possible.



**Figure 26.** This is a feed belt adjustment bolt.





# V-Belt Tension

The sanding belt is driven by two V-belts on the Model G9983. The V-belts must have adequate tension for proper power transmission. Proper tension is usually achieved when the V-belts can be deflected no more than 1" with moderate finger pressure at the midpoint between the wide-belt pulleys and the motor pulleys. The large cover on the right-hand side of the sander must be removed to access the V-belts and the sanding motor.

Thread the nuts shown in **Figure 27** down to tighten the V-belts, or thread the nuts up to loosen the V-belts.

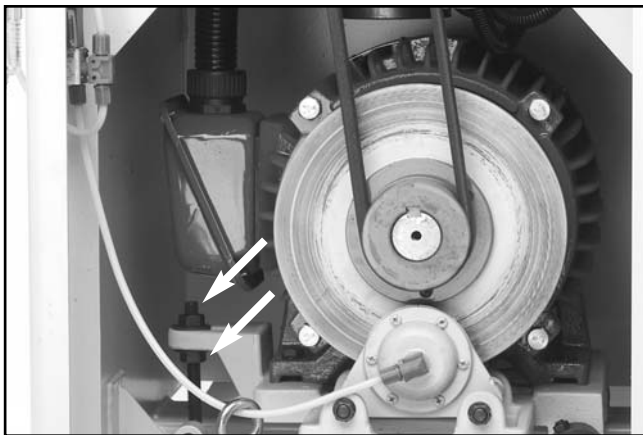

**Figure 27.** Turning these nuts allows you to raise/lower the motor to adjust the V-belts.

## CAUTION

Always inspect V-belts for damage or deterioration when adjusting for tension. Should you find evidence of cracking, abrasion or damage from wood chips or other foreign materials, replace the belt immediately. Belt breakage may lead to mechanical damage or operator injury.



# Replacing V-Belts

Inspect the V-belts closely; if you see any glazing, cracking or fraying, replace the belts. Always replace the two V-belts at the same time for proper power transmission.

## To replace the V-belts:

1. **Disconnect sander from the power source and shut off air pressure.**
2. Loosen the top nut on the motor adjustment bolt shown in **Figure 28**. Turn the bottom nut counterclockwise to raise the motor (or pry motor up with a scrap piece of wood) and loosen the V-belts.

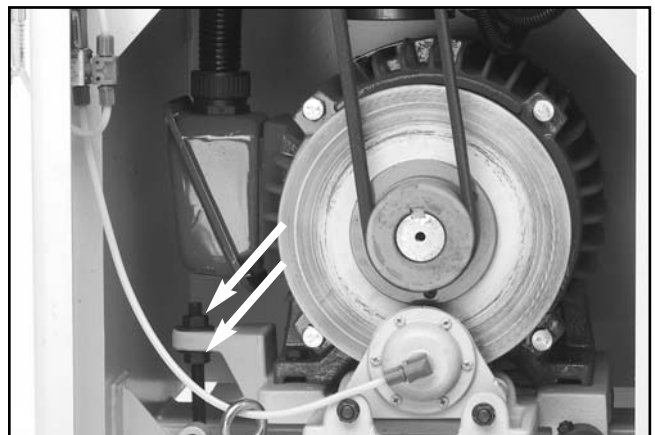

**Figure 28.** Loosen the V-belt by using the adjustment nuts.

3. When V-belts are sufficiently loose, slide them off of the motor pulley.
4. To remove the V-belts from the roller pulley, the roller needs to be removed. Open the left-hand access door and remove the platen micro-adjust knob by loosening the setscrew that secures the face. The plate underneath the knob is secured to the casting by two setscrews—remove these. **Figure 29** shows the knob and indicator plate removed from the casting.
5. Remove the large cap screws, also shown in **Figure 29**, to loosen the casting on the roller shafts.

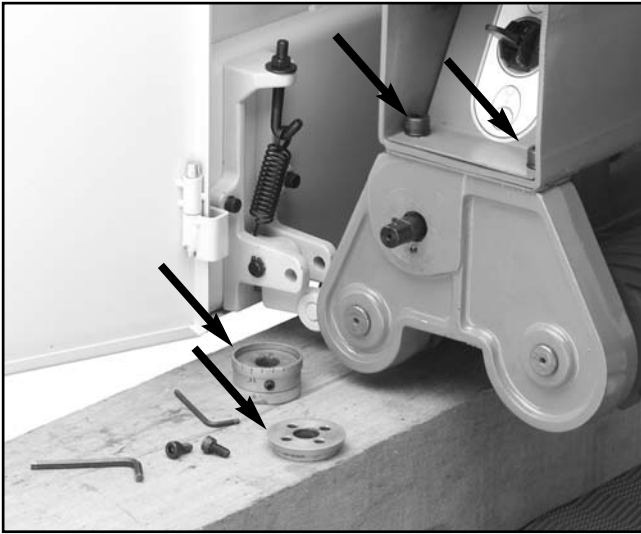

**Figure 29.** Remove platen adjustment knob, indicator plate, and large cap screws.

6. Work the casting off the roller shafts as shown in **Figure 30**.



**Figure 30.** Work the casting off the roller shafts.

7. Open the right-hand access door and locate the large nut shown in **Figure 31** and remove it with the box wrench included with the machine.

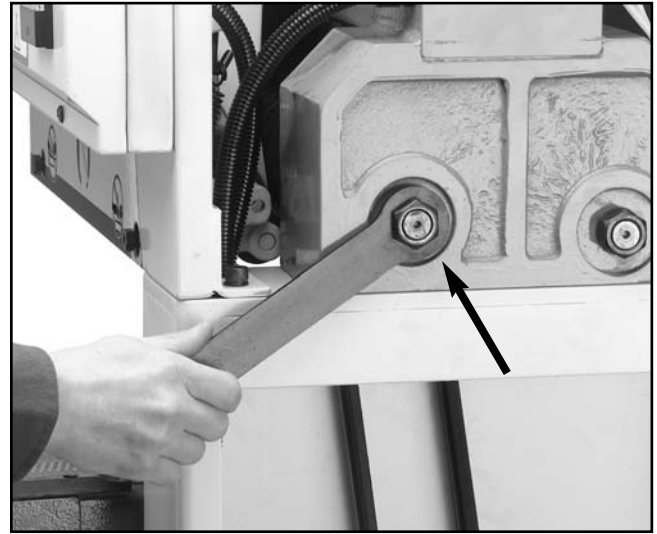

**Figure 31.** Remove this roller shaft nut located behind right-hand access door.

8. Slide out the front roller shaft, as shown in **Figure 32**, to get the V-belts off of the pulley.



**Figure 32.** Remove roller.

9. Installation is the reverse of removal. If possible, have an assistant help you when installing the V-belts and the roller. Also, an assistant can be helpful on the other end of the roller when tightening the nuts on the roller shafts.

## NOTICE

**New V-belts will often stretch after moderate use. Check frequently after installation.**



# Platen Graphite

---

---

The graphite sheet on the platen will wear out with use. Similar to the sanding belts, the graphite sheet is considered a “consumable” item and is not covered under the warranty. We recommend keeping replacements in your inventory to avoid downtime. To obtain replacements, use the part number in the back of this manual for ordering.

## To replace the graphite sheet:

1. Pull the platen from its bracket with the included platen puller tool.
2. Remove the screws and hold-down bar that secure the graphite sheet to the platen.
3. Install the new graphite sheet exactly the reverse as removal. *Make sure that the graphite sheet is wrapped in the same direction as the old one.*



# Air System

---

---

The air system is durable and reliable; however, components do wear with age. If you suspect that an item in your air system may be having problems, use the diagram on **page 38** to follow all lines and connections, and use the instructions below to investigate.

- Carefully inspect all air lines for cracks, tears or hardening. Replace faulty hoses.
- Check the air connections for leaks. A small amount of water in a questionable area will bubble if there is a leak.
- Make sure lines are not clogged. Remove a questionable line and blow through it as a test.

## CAUTION

If you ever determine that a component in the air system is malfunctioning, **DO NOT** operate the sander. Fix the problem before resuming operation.



# Replacing Brakes

---

---

The only regular maintenance to perform on the brakes is to keep the rotor clean. This is a simple process and can be performed by spraying both sides of the rotor with automotive brake parts cleaner. The brake rotor must be free and clean of any dust, dirt, oil or moisture.

Eventually the brake pads will wear out. Checking and replacing these is a simple project that can be done in the shop, with the exception of having the rotor resurfaced.

## To check the brake pads:

1. **Disconnect the sander from the power source and remove the air pressure completely.**
2. Remove the four screws that secure the motor cover on the right-hand side of the machine. This will allow you to access the brake components.
3. The brake pads consist of a metal plate with a composite pad. With a fine ruler, measure the thickness of the composite pad only. If one of the pads is below  $\frac{1}{8}$ " (approx. 3mm), replace both.

## To replace the brake pads:

1. **Disconnect the sander from the power source and remove the air pressure completely.**
2. Remove the nuts from the two mounting bolts. There are two snap rings on the mounting pins behind the bracket. Remove these.
3. Pull the mounting pins out of the caliper bracket and remove the air line from the caliper. The caliper should now be able to be removed as in **Figure 33**.

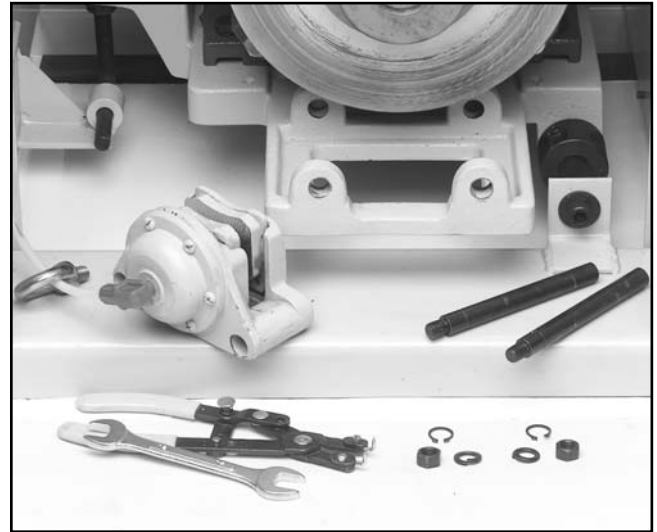

**Figure 33.** Removing caliper to replace brake pads.

4. The brake pads are secured to the caliper with cap screws. One of these screws is easily accessible; the other can only be reached by disassembling the brake caliper. Do this and remove the cap screws to remove the brake pads.
5. Remove the brake rotor and have it professionally resurfaced. For this, find a local machinist or auto supply store that regularly resurfaces brake rotors for automobiles. If visible cracks are present in the brake rotor, replace with a new one. Clean the rotor with automotive brake cleaner to remove any oil or dirt. Handle with a dry rag and install exactly the reverse of removal.
6. Install new brake pads, mount the caliper and reconnect the air line.





# SECTION 8: CLOSURE

---

The following pages contain general machine data, parts diagrams/lists, a troubleshooting guide and Warranty/Return information for your Model G9983 Wide-belt Sanders.

If you need parts or help in assembling your machine, or if you need operational information, we encourage you to call our Service Department. Our trained service technicians will be glad to help you.

If you have comments dealing specifically with this manual, please write to our Bellingham, Washington location using the address in *Section 2: Introduction*. The specifications, drawings, and photographs illustrated in this manual represent the Model G9983 as supplied when the manual was prepared. However, due to Grizzly's policy of continuous improvement, changes may be made at any time with no obligation on the part of Grizzly. Whenever possible, though, we send manual updates to all owners of a particular tool or machine. Should you receive one, add the new information to this manual and keep it for reference.

We have included some important safety measures that are essential to this machine's operation. While most safety measures are generally universal, Grizzly reminds you that each workshop is different and safety rules should be considered *as they apply to your specific situation*.

## WARNING

This equipment has the potential to create flying debris which can cause severe eye injury. Always wear safety glasses or goggles when operating equipment. Everyday glasses or reading glasses only have impact resistant lenses, they are not safety glasses. Be certain the safety glasses you wear meet the appropriate standards of the American National Standards Institute (ANSI).

We recommend you keep a copy of our current catalog for complete information regarding Grizzly's warranty and return policy. If you need additional technical information relating to this machine, or if you need general assistance or replacement parts, please contact the Service Department listed in *Section 3: Introduction*.

Additional information sources are necessary to realize the full potential of this machine. Trade journals, woodworking magazines, and your local library are good places to start.

## WARNING

The Model G9983 was specifically designed for sanding wood. **DO NOT MODIFY AND/OR USE THIS MACHINE FOR ANY OTHER PURPOSE.** Modifications or improper use of this tool will void the warranty. If you are confused about any aspect of this machine, **DO NOT** use it until all your questions have been answered. Serious personal injury may occur.

## WARNING

Like all power tools, there is danger associated with the Model G9983 Wide-belt Sander. Accidents are frequently caused by lack of familiarity or failure to pay attention. Use this tool with respect and caution to lessen the possibility of operator injury. If normal safety precautions are overlooked or ignored, serious personal injury may occur.





# MACHINE DATA SHEET

Customer Service #: (570) 546-9663 • To Order Call: (800) 523-4777 • Fax #: (800) 438-5901

## MODEL G9983 15" OPEN-END WIDE-BELT SANDER

Design Type .....Floor Model - Open End

### Overall Dimensions:

Height .....61¾"  
Width .....35"  
Depth .....32½"  
Shipping Weight.....923 lbs.  
Net Weight .....815 lbs.  
Foot Print .....29 x 23½"  
Crate Size.....35½" L x 37" W x 70" H

### Capacities:

Maximum Board Width (in one pass) .....15"  
Maximum Board Thickness .....5½"  
Minimum Board Length .....12"  
Surface Speed of Sanding Belt .....2050 FPM  
Conveyor Feed Rate .....13.1 & 16.4 FPM  
Sanding Belt Size.....16" x 48"

### Sanding Motor:

Horsepower.....5 HP  
Voltage .....220V  
Amps.....30  
RPM .....1725  
Phase/Cycle .....Single/60 HZ  
Power Transfer.....2 V-Belt Drive

### Conveyor Motor:

Horsepower .....¼ HP  
Voltage .....220V  
Amps .....1.8  
RPM .....1725  
Phase/Cycle .....Single/60 HZ  
Power Transfer.....Gear Box to Chain

### General Construction:

Cabinet .....Steel  
Belt Drums .....Rubber Infeed Drum  
.....Steel Outfeed  
.....Rubber Pressure Rollers

### Features:

.....Independent Motor Control  
.....Pneumatic Belt Tensioning  
.....Pneumatic Belt Tracking  
.....Load Meter  
.....Safety Shut-Off Bar  
.....Thickness Scale  
.....Disc Brake System for Emergency Stops  
.....5" Dust Port

*Specifications, while deemed accurate, are not guaranteed.*

# Air System

Various functions on the Model G9983 are controlled through the air system. Since this is a complex network of hoses and valves, please take some time to familiarize yourself with each item so you can better understand your machine during adjustments.

The illustration below follows the air travel through the machine to familiarize you with how it works. Match the letters in the text with those in the illustration to learn more about each function.

1. The air flows into the machine at the pressure regulator (A). This should be adjusted to 75 PSI.
2. The solenoid valve (C) controls the brake caliper (B) when signaled by the emergency stop switch or the limit switches.
3. The switching valve (E) controls the vertical cylinder (D) which raises/lowers the top roller (M) to tighten/loosen the sanding belt.
4. The valve (G) controls the air flow volume that goes to the air eye fork (F), which controls the belt oscillation return.
5. The diaphragm (H) actuates the switching valve (I) depending on whether air is coming from the eye fork (F) or the pressure regulator (A).
6. Switching valve (I) actuates the diaphragm (J), which controls oscillation arm (K), which in turn, moves eccentric shaft (L), which makes top roller (M) shift back and forth to control belt movement during operation.
7. Valve (O) controls the speed at which the belt moves back and forth.
8. Knob (N) allows you to rotate the eccentric shaft (L) to balance the oscillation timing so it takes the belt the same amount of time to move in one direction as it moves in the other direction.

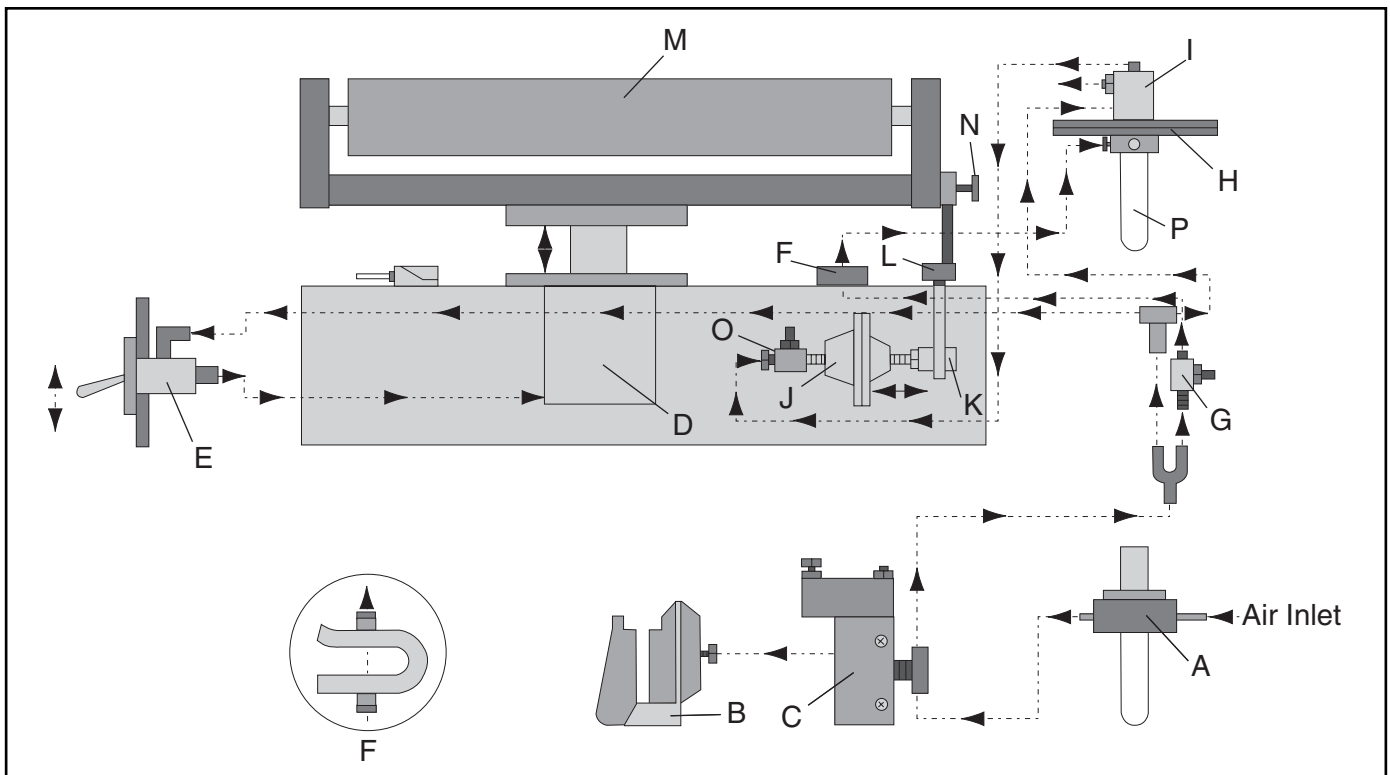

This is an illustration of the air control system.



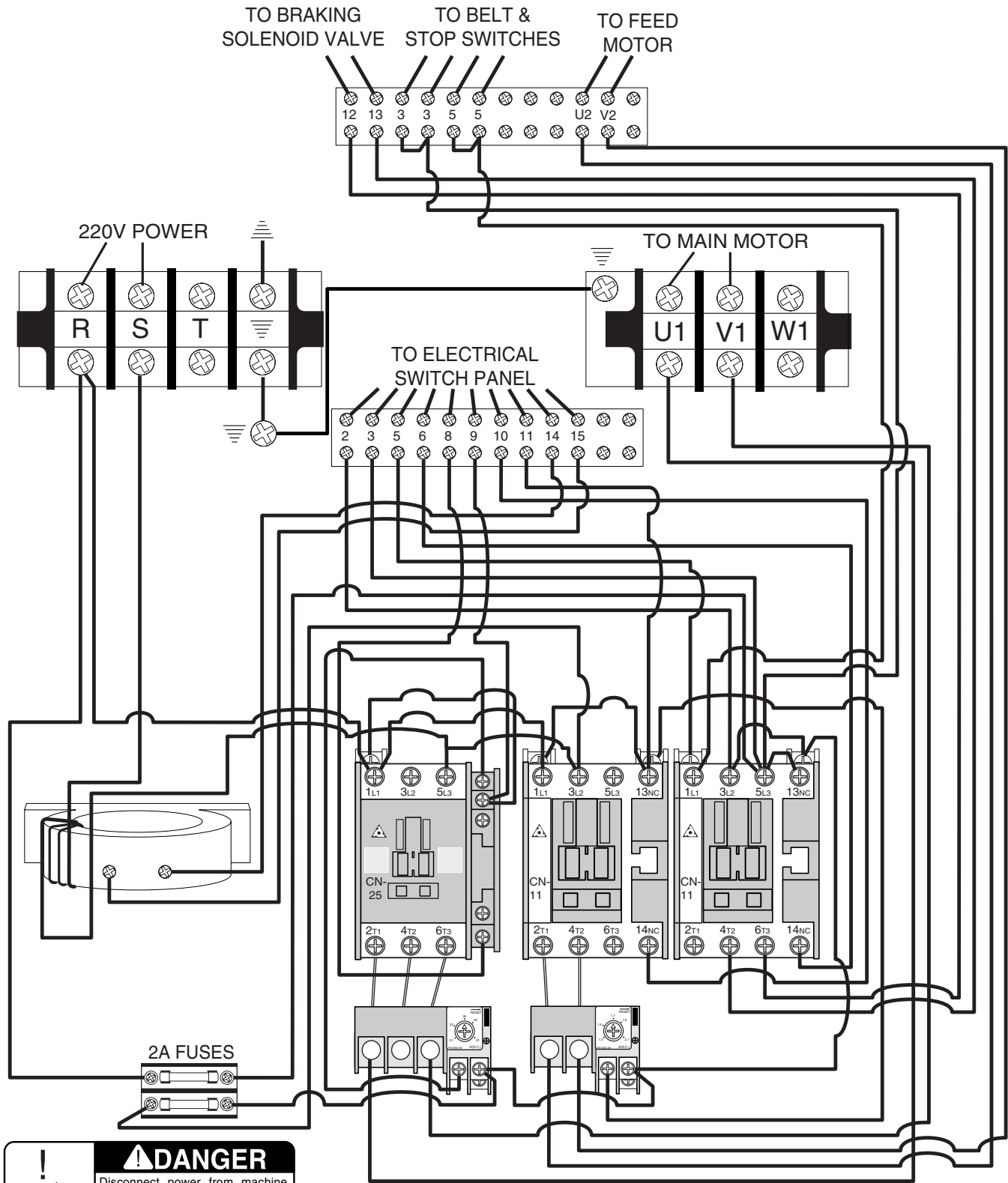

**! DANGER**  
 Disconnect power from machine before performing any electrical service. Failure to do this will result in a shock hazard leading to injury or death.

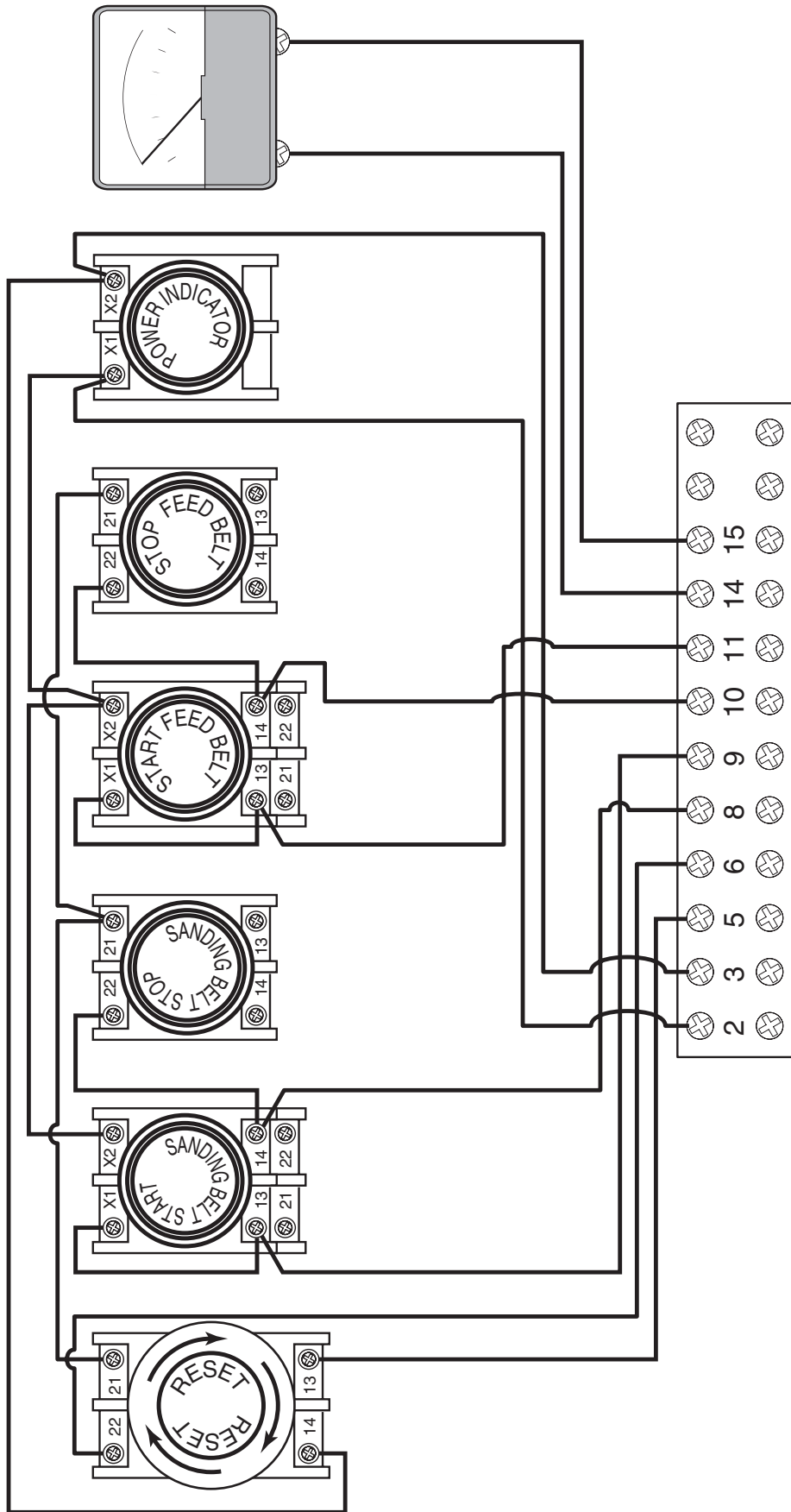

**⚠ DANGER**

Disconnect power from machine before performing any electrical service. Failure to do this will result in a shock hazard leading to injury or death.

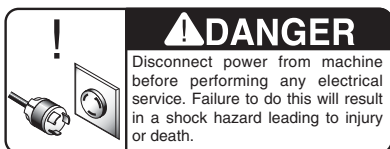
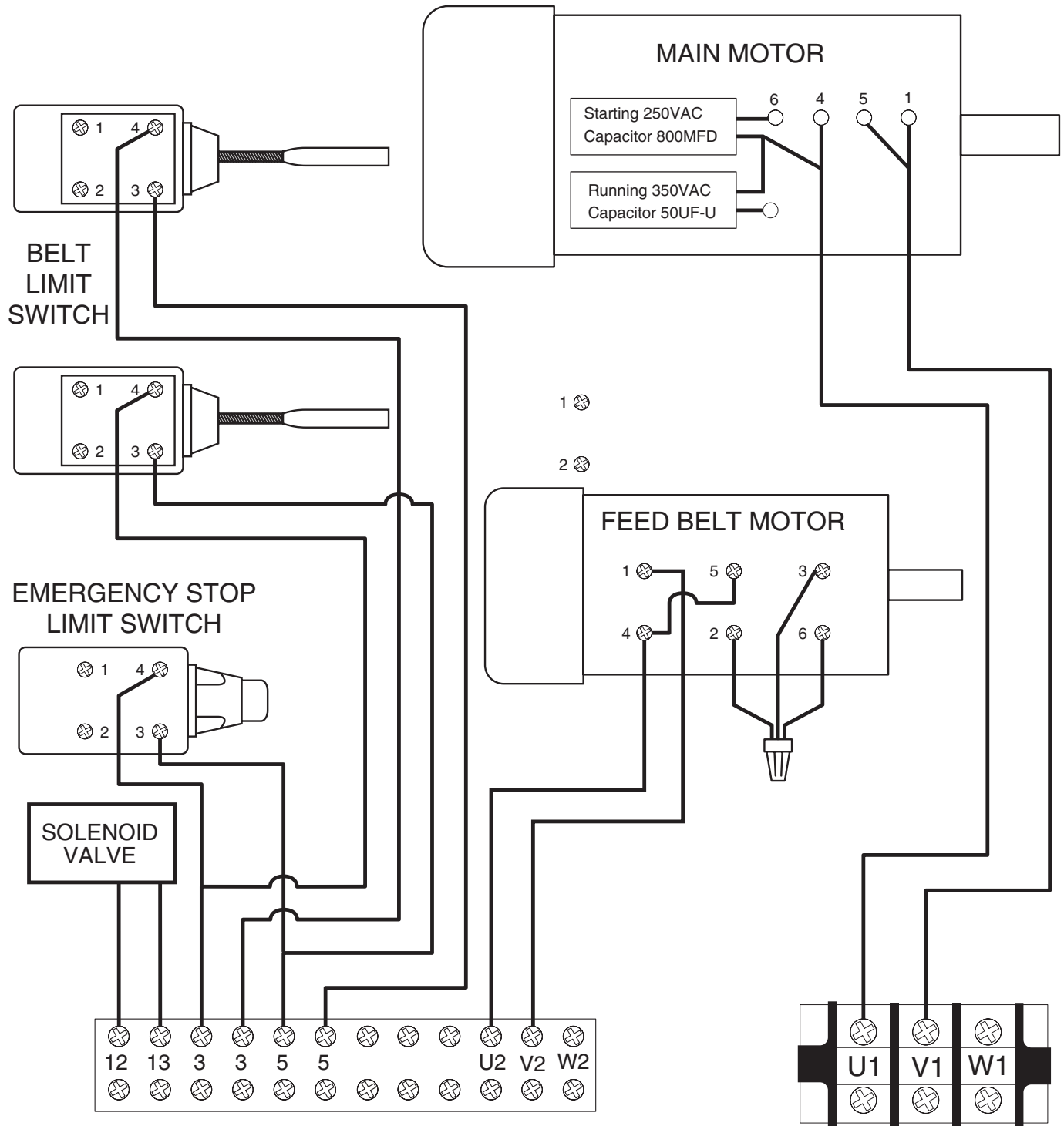

# G9983 Parts Breakdown

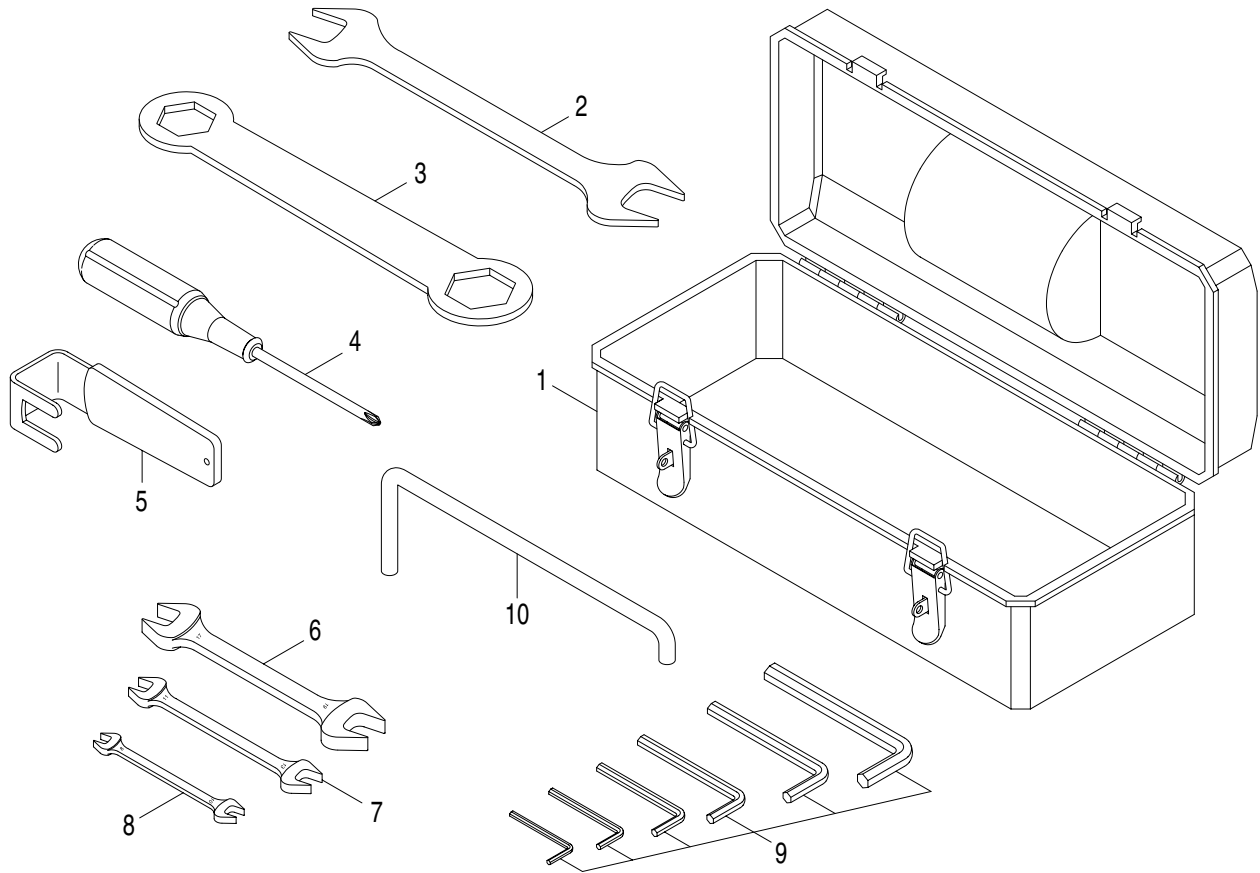

REF	PART #	DESCRIPTION
1	P9983001	TOOL BOX
2	PWR1214	COMBO WRENCH 12/14MM
3	P9983003	BOX WRENCH 30/37MM
4	P4000937	PHILLIPS SCREWDRIVER
5	P9983005	ACCESS DOOR HANDLE

REF	PART #	DESCRIPTION
6	PWR1719	COMBO WRENCH 17/19MM
7	PWR1113	COMBO WRENCH 11/13MM
8	PWR810	COMBO WRENCH 8/10MM
9	P9983009	ALLEN WRENCH SET (10)
10	P9983010	PLATEN TOOL

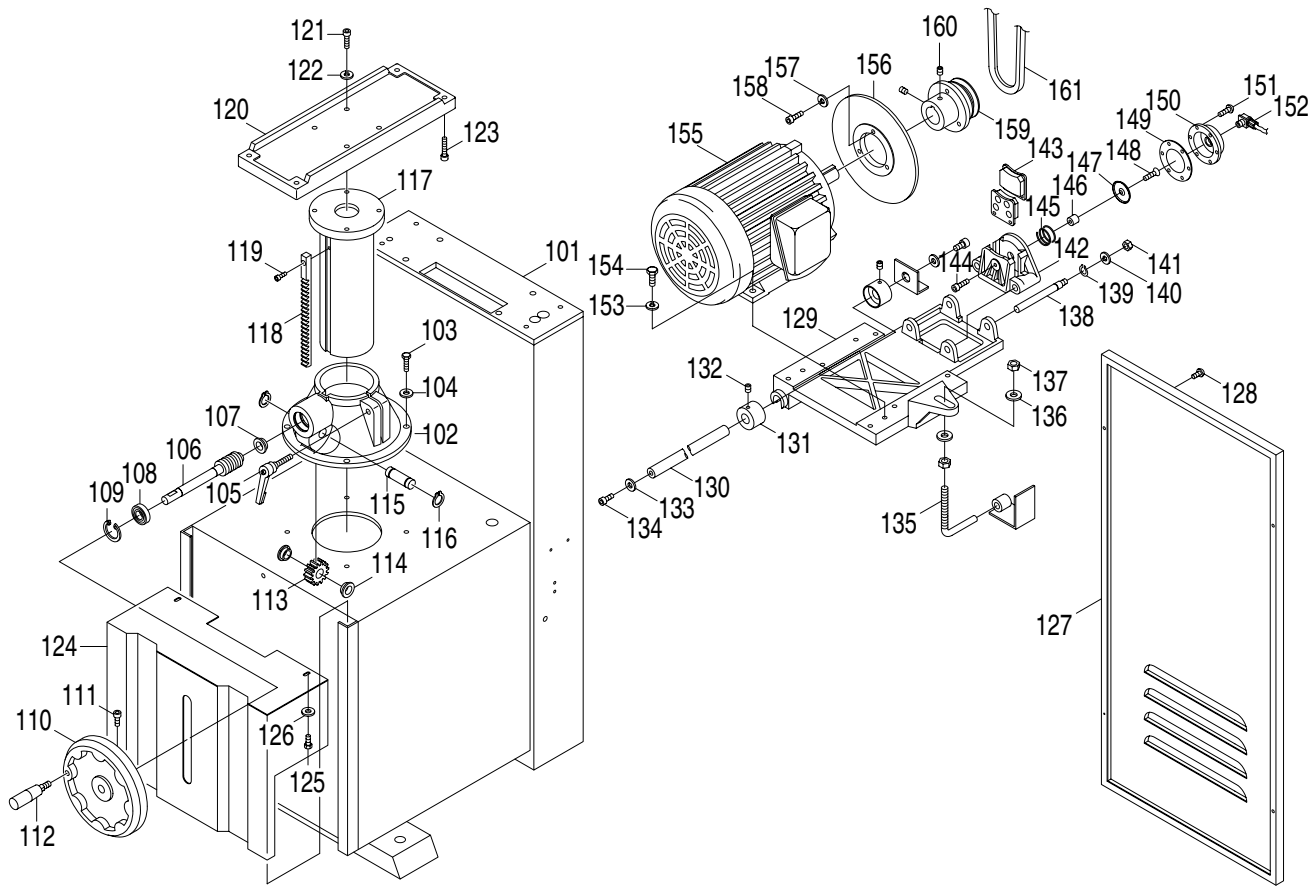

REF	PART #	DESCRIPTION
101	P9983101	MACHINE BASE
102	P9983102	QUILL BASE
103	PSB64M	CAP SCREW M10-1.5 X 25
104	P9983104	LOCK WASHER 10MM
105	P9983105	LOCKING HANDLE
106	P9983106	WORM GEAR SHAFT
107	P51102	BEARING 51102
108	P6203	BEARING 6203ZZ
109	PR23M	INT RETAINING RING 40MM
110	P9983110	HANDWHEEL
111	PSB64M	CAP SCREW M10-1.5 X 25MM
112	P9983112	HANDLE M10
113	P9983113	WORM GEAR
114	P9983114	BUSHING
115	P9983115	GEAR SHAFT
116	PR18M	EXT RETAINING RING 17MM
117	P9983117	QUILL
118	P9983118	RACK
119	PSB26M	CAP SCREW M6-1.0 X 12
120	P9983120	CONVEYOR SUPPORT
121	PSB12M	CAP SCREW M8-1.25 X 40
122	PLW04M	LOCK WASHER 8MM
123	PSB12M	CAP SCREW M8-1.25 X 40
124	P9983124	QUILL COVER
125	PS14M	PHLP HD SCR M6-1.0 X 12
126	P9983126	FLAT WASHER 6MM
127	P9983127	MACHINE BASE COVER
128	PS47M	PHLP HD SCR M6-1.0 X 25
129	P9983129	MOTOR BASE
130	P9983130	SETTING SHAFT
131	P9983131	LOCK BUSHING

REF	PART #	DESCRIPTION
132	PSS09M	SETSCREW M8-1.25 X 20
133	PW04M	FLAT WASHER 10MM
134	PSB62M	CAP SCREW M10-1.5 X 12
135	P9983135	ADJUSTABLE SCREW
136	PW06M	FLAT WASHER 12MM
137	PN09M	HEX NUT M12-1.75
138	P9983138	BRAKE PIN
139	PR47M	EXT RETAINING RING 13MM
140	PLW06M	LOCK WASHER 10MM
141	PN02M	HEX NUT M10-1.5
142	P9983142	BRAKE CALIPER
143	P9983143	BRAKE PAD
144	PS14M	CAP SCREW M6-1.0 X 12
145	P9983145	SPRING
146	P9983146	BRAKE AXLE
147	P9983147	PLATE
148	PS47M	PHLP HD SCR M6-1.0 X 25
149	P9983149	DIAPHRAGM
150	P9983150	TOP COVER
151	PS20M	PHLP HD SCR M5-.08 X 15
152	P9983152	PLASTIC CONNECTOR
153	PLW06M	LOCK WASHER 10MM
154	PB01M	HEX BOLT M10-1.5 X 30
155	P9983155	SPINDLE MOTOR 5HP
156	P9983156	BRAKE ROTOR
157	PLW06M	LOCK WASHER 10MM
158	PSB75M	CAP SCREW M10-1.5 X 18
159	P9983159	MOTOR PULLEY
160	PSS13M	SETSCREW M10-1.5 X 12
161	PVA71	BELT A71

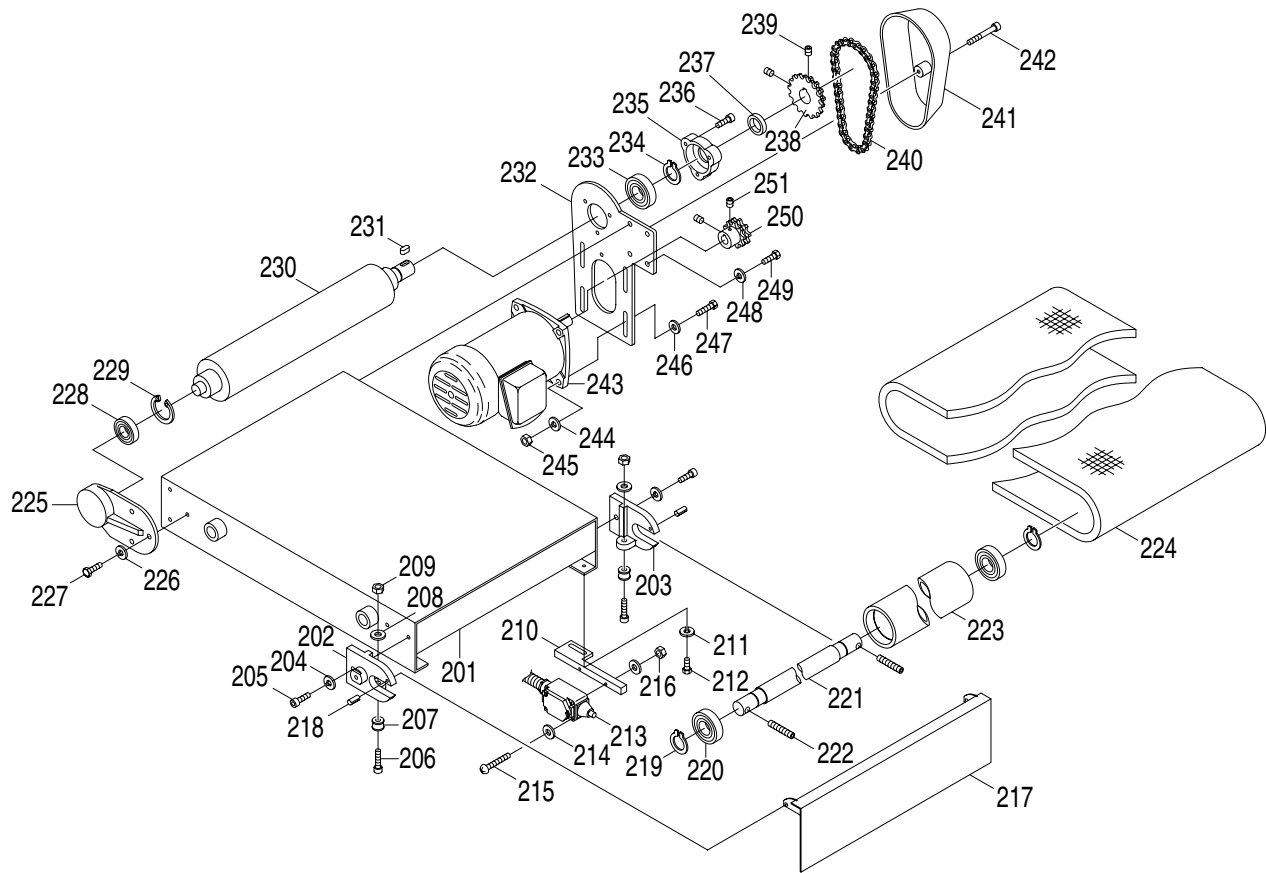

REF	PART #	DESCRIPTION
201	P9983201	CONVEYOR SUPPORT
202	P9983202	ROLLER BRACKET LH
203	P9983203	ROLLER BRACKET RH
204	PLW04M	LOCK WASHER 8MM
205	PB07M	HEX BOLT M8-1.25 X 25
206	PSB40M	CAP SCREW M8-1.25 X 35
207	P9983207	BRASS ROLLER
208	PLW04M	LOCK WASHER 8MM
209	PN03M	HEX NUT M8-1.25
210	P9983210	LIMIT SWITCH BASE
211	PW03M	FLAT WASHER 6MM
212	PS14M	PHLP HD SCR M6-1.0 X 12
213	P9983213	LIMIT SWITCH
214	PW05M	FLAT WASHER 4MM
215	PS48M	PHLP HD SCR M4-.7 X 50
216	PN04M	HEX NUT M4-.7
217	P9983217	E-BRAKE PANEL
218	PRP03M	PIN 5 X 20MM
219	PR11M	EXT RETAINING RING 25MM
220	P6305	BEARING 6305ZZ
221	P9983221	CONVEYOR AXLE
222	PSS39M	SETSCREW M10-1.5 X 50
223	P9983223	CONVEYOR ROLLER
224	P9983224	CONVEYOR BELT 380 X 1600
225	P9983225	BEARING SEAT
226	PLW04M	LOCK WASHER 8MM

REF	PART #	DESCRIPTION
227	PB09M	HEX BOLT M8-1.25 X 20
228	P6204	BEARING 6204ZZ
229	PR25M	INT RETAINING RING 47MM
230	P9983230	MAIN ROLLER
231	PK67M	KEY 8 X 7 X 15MM
232	P9983232	MOTOR PANEL
233	P6205	BEARING 6205ZZ
234	PR11M	EXT RETAINING RING 25MM
235	P9983235	BEARING COVER
236	PSB74M	CAP SCREW M6-1.0 X 18
237	P9983237	BUSHING
238	P9983238	CHAIN WHEEL 19T X 24T
239	PSS02M	SETSCREW M6-1.0 X 6
240	P9983240	CHAIN 3/8" X 48PC
241	P9983241	ROLLER CHAIN COVER
242	PSB37M	CAP SCREW M6-1.0 X 50
243	P9983243	FEED MOTOR 1/4 HP
244	PLW04M	LOCK WASHER 8MM
245	PN03M	HEX NUT M8-1.25
246	PW01M	FLAT WASHER 8MM
247	PB26M	HEX BOLT M8-1.25 X 30
248	PLW04M	LOCK WASHER 8MM
249	PB09M	HEX BOLT M8-1.25 X 20
250	P9983250	CHAIN WHEEL 12T, 14T
251	PSS02M	SETSCREW M6-1.0 X 6

# G9983

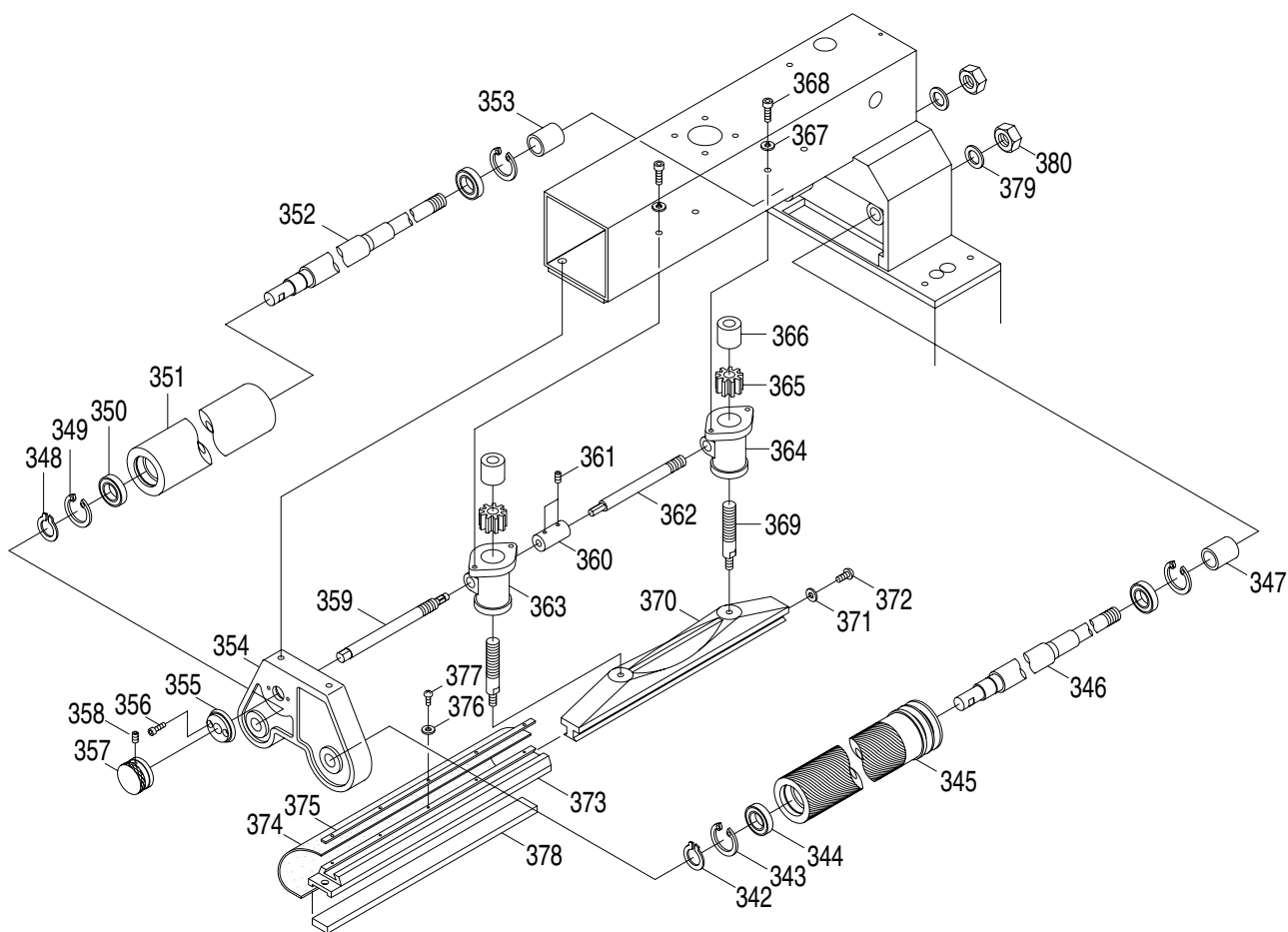
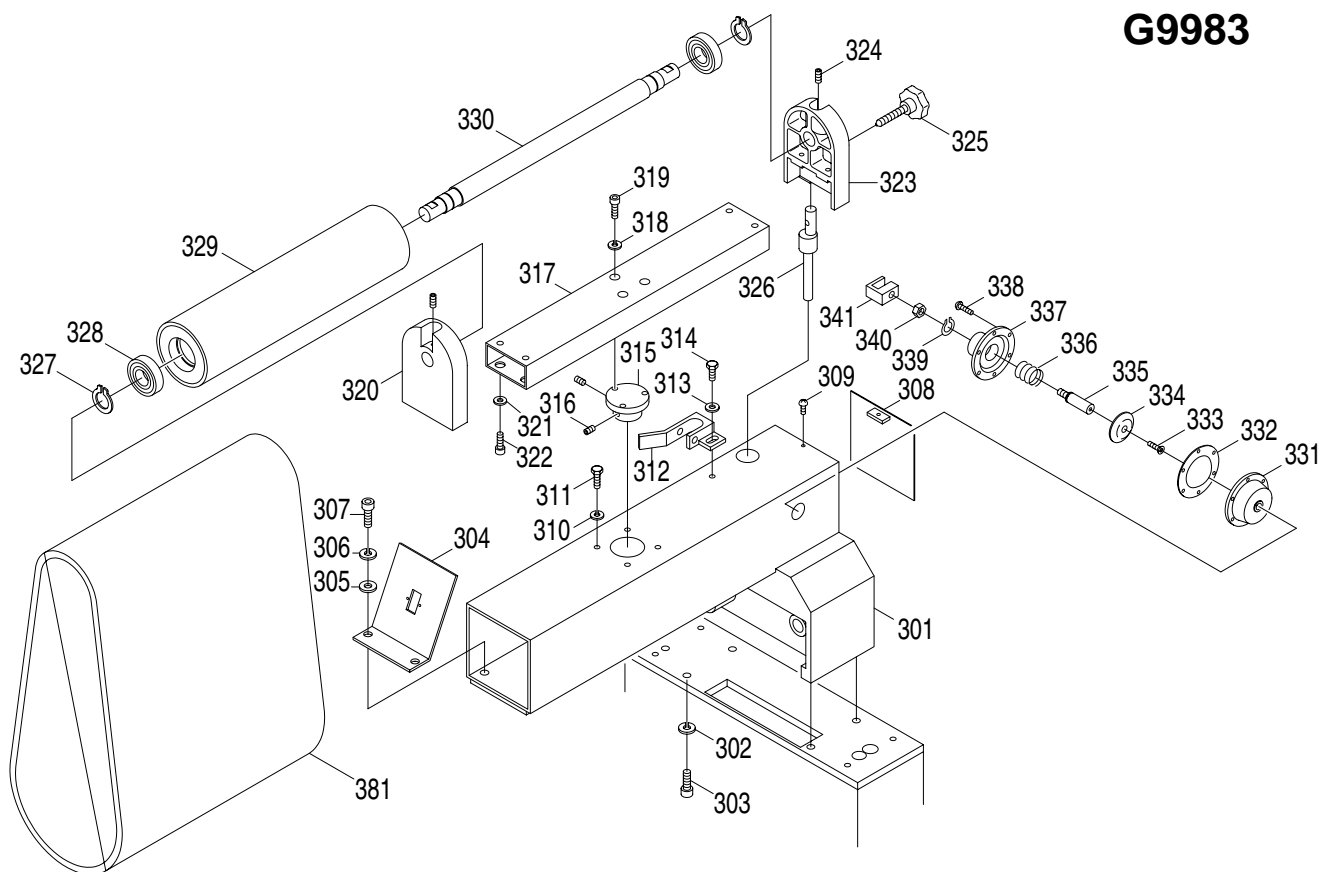



REF	PART #	DESCRIPTION
301	P9983301	CONTACT ROLLER BASE
302	PLW06M	LOCK WASHER 10MM
303	PSB72M	CAP SCREW M10-1.5 X 30
304	P9983304	SWITCH PLATE
306	PLW06M	LOCK WASHER 10MM
307	PSB72M	CAP SCREW M10-1.5 X 30
308	P9983308	COVER
309	PS02M	PHLP HD SCR M4-.07 X 12
310	PLW04M	LOCK WASHER 8MM
311	PB07M	HEX BOLT M8-1.25 X 25
312	P9983312	FORK
313	PW03M	FLAT WASHER 6MM
314	PS14M	PHLP HD SCR M6-1.0 X 12
315	P9983315	CYLINDER ROLLER FRAME
316	PSS04M	SETSCREW M6-1.0 X 12
317	P9983317	SUPPORT TUBE
318	PLW04M	LOCK WASHER 8MM
319	PSB76M	CAP SCREW M8-1.25 X 18
320	P9983320	TOP ROLLER SUPPORT
321	PLW04M	LOCK WASHER 8MM
322	PSS41M	SETSCREW M8-1.25 X 18
323	P9983323	TOP ECCENTRIC FRAME
324	PSB26M	CAP M6-1.0 X 12MM
325	P9983325	KNOB BOLT M8 X 55
326	P9983326	ECCENTRIC SHAFT
327	PR11M	EXT RETAINING RING 25MM
328	P6205	BEARING 6205ZZ
329	P9983329	TOP ROLLER
330	P9983330	TOP ROLLER SHAFT
331	P9983331	TOP COVER
332	P9983332	DIAPHRAGM
333	PS14M	PHLP HD SCR M6-1.0 X 12
334	P9983334	PLATE
335	P9983335	SHAFT
336	P9983336	SPRING
337	P9983337	BOTTOM COVER
338	PS06M	PHLP HD SCR M5-.8 X 20
339	PR05M	EXT RETAINING RING 15MM
340	PN02M	HEX NUT M10-1.5
341	P9983341	OSCILLATION SQUARE

REF	PART #	DESCRIPTION
342	PR11M	EXT RETAINING RING 25MM
343	PR25M	INT RETAINING RING 47MM
344	P6005	BEARING 6005ZZ
345	P9983345	CONTACT ROLLER
346	P9983346	ROLLER SHAFT
347	P9983347	SLEEVE
348	PR11M	RETAINING RING S25
349	PR25M	RETAINING RING R47
350	P6005	BEARING 6005ZZ
351	P9983351	SUPPORT ROLLER
352	P9983352	ROLLER SHAFT
353	P9983353	BUSHING
354	P9983354	ROLLER BASE
355	P9983355	MICROMETER BASE
356	PSB26M	CAP SCREW M6-1.0 X 12
357	P9983357	MICROMETER
358	PSS04M	SETSCREW M6-1.0 X 12
359	P9983359	MAIN WORM GEAR SHAFT
360	P9983360	CONNECTION COUPLING
361	PSS04M	SETSCREW M6-1.0 X 12
362	P9983362	SUPP WORM GEAR SHAFT
363	P9983363	GRAPHITE BASE L
364	P9983364	GRAPHITE BASE R
365	P9983365	WORM GEAR
366	P9983366	GEAR BUSHING
367	PLW04M	LOCK WASHER 8MM
368	PB03M	HEX BOLT M8-1.25 X 16
369	P9983369	VERT MICROMETER SCREW
370	P9983370	PLATEN (MALE)
371	PW01M	FLAT WASHER 8MM
372	PSB58M	CAP SCREW M8-1.25 X 12
373	P9983373	PLATEN (FEMALE)
374	P9983374	CARBON GRAPHITE
375	P9983375	SET PLATE
376	PW05M	FLAT WASHER 4MM
377	PS02M	PHLP HD SCR M4-.7 X 12
378	P9983378	LINING 30 X 415MM
379	PLW07M	LOCK WASHER 20MM
380	PN17M	HEX NUT M20-1.5
381	P9983381	SANDING BELT 16"W X 48"

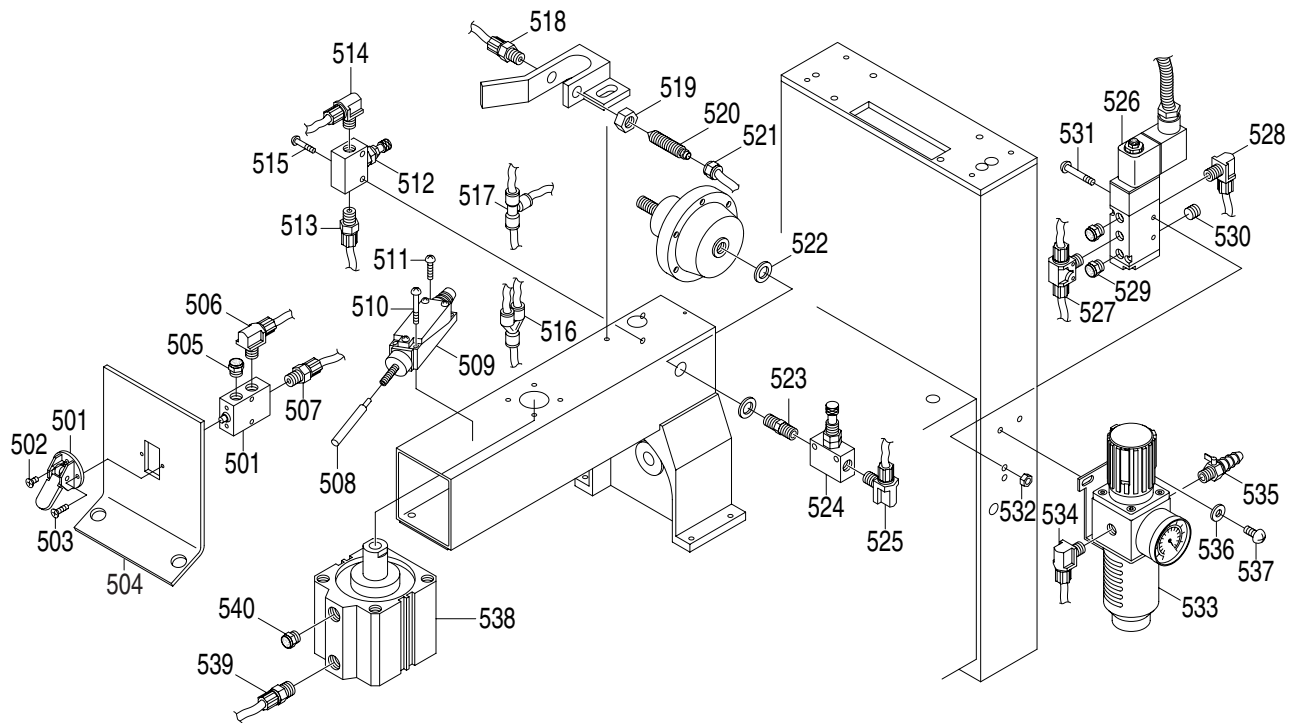
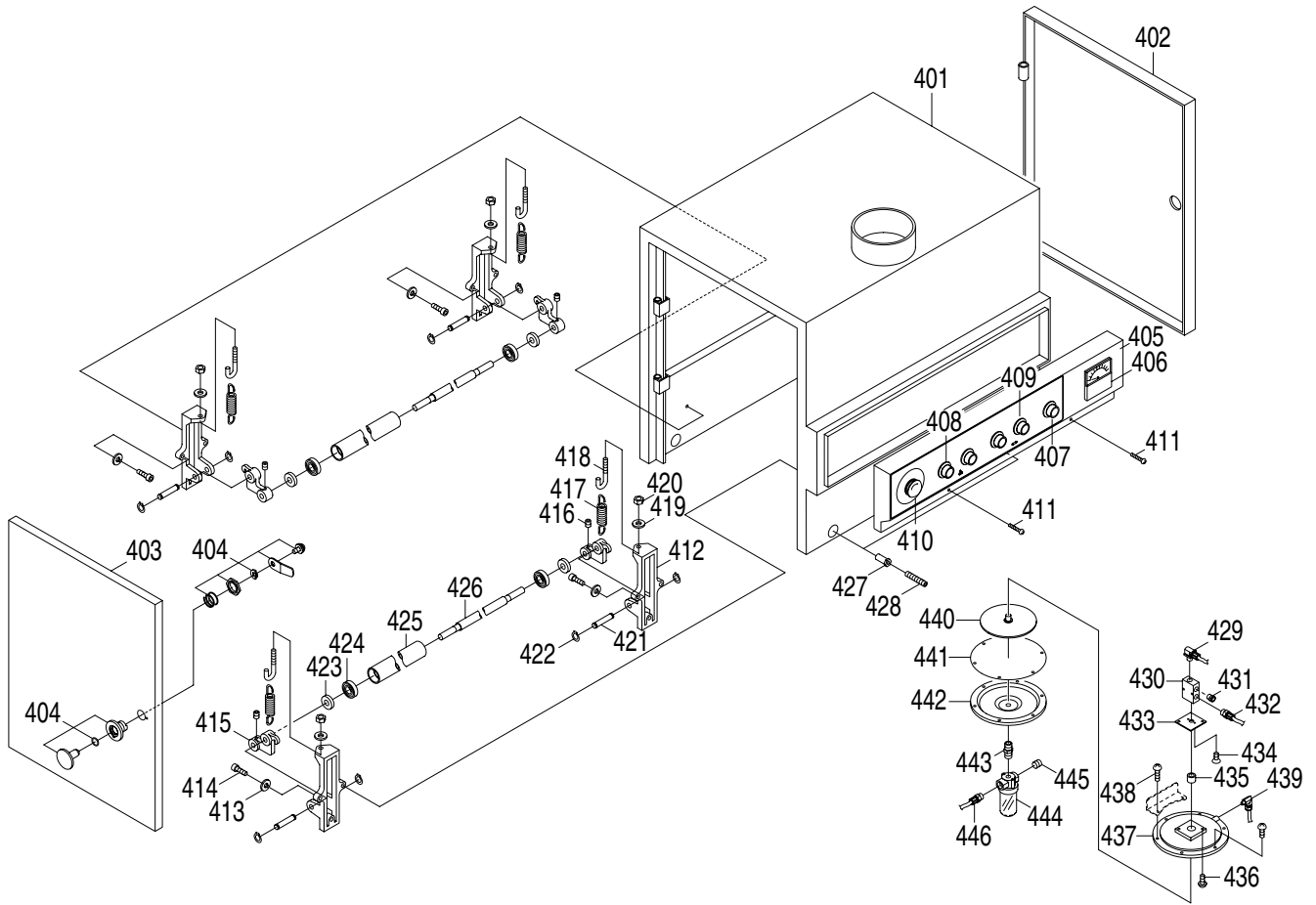

REF	PART #	DESCRIPTION
401	P9983401	MACHINE FRAME
402	P9983402	ACCESS DOOR RH
403	P9983403	ACCESS DOOR LH
404	P9983404	LOCK
405	P9983405	OPERATING PANEL
406	P9983406	LOAD METER
407	P9983407	POWER INDICATOR
408	P9983408	START BUTTON
409	P9983409	STOP BUTTON
410	P9983410	EMERGENCY STOP BUTTON
411	PS47M	PHLP HD SCR M6-1.0 X 25
412	P9983412	PRESSURE ROLLER FRAME
413	PLW03M	LOCK WASHER 6MM
414	PSB06M	CAP SCREW M6-1.0 X 25
415	P9983415	TILTING ARM
416	PSS26M	SETSCREW M5-08 X 6
417	P9983417	SPRING
418	P9983418	SPRING HOOK
419	PW01M	FLAT WASHER 8MM
420	PN03M	HEX NUT M8
421	P9983421	SET PIN
422	PR01M	EXT RETAINING RING 10MM
423	P9983423	BEARING COVER
424	P6001	BEARING 6001ZZ
425	P9983425	PRESSURE ROLLER
426	P9983426	PRESSURE SHAFT
427	P9983427	SPECIAL NUT M8-1.25
428	PSS42M	SETSCREW M8-1.25 X 50
429	P9983429	PLASTIC CONNECTOR L6-1/8"
430	P9983430	SWITCHING VALVE 1/8"
431	P9983431	SILENCER 1/8"
432	P9983432	PLASTIC CONNECTOR C6-1/8"
433	P9983433	LINING
434	PS49M	PHLP HD SCR M3-.5 X 5
436	PS02M	PHLP HD SCR M4-.7 X 12
437	P9983437	TOP ALUMINUM COVER
438	PS06M	PHLP HD SCR M5-.8 X 20
439	P9983439	PLASTIC CONNECT M6 X 1/4"
440	P9983440	PLATE
441	P9983441	DIAPHRAGM
442	P9983442	BOTTOM ALUMINUM COVER
443	P9983443	PLASTIC CONNECT 1/8" X 1/8"
444	P9983444	CUP 1/4"

REF	PART #	DESCRIPTION
445	P9983445	CONNECTOR 1/4"
446	P9983446	PLASTIC CONNECT C6-1/4"
501	P9983501	SWITCHING VALVE
502	PS12M	PHLP HD SCR M3-.5 X 6
503	PS12M	PHLP HD SCR M3-.5 X 6
504	P9983504	LIMIT SWITCH PANEL
505	P9983505	SILENCER 1/8"
506	P9983506	PLASTIC CONNECT L6-1/8"
507	P9983507	PLASTIC CONNECT C6-1/8"
508	P9983508	SENSOR PIN
509	P9983509	LIMIT SWITCH 8166
510	PS50M	PHLP HD SCR M3-.5 X 12
511	PS50M	PHLP HD SCR M3-.5 X 12
512	P9983512	AIR VALVE 1/8"
513	P9983513	PLASTIC CONNECT C6-1/8"
514	P9983514	PLASTIC CONNECT L6-1/8"
515	PS52M	PHLP HD SCR M4-.7 X 20
516	P9983516	PLASTIC CONNECT 6Y
517	P9983517	PLASTIC CONNECT 6T
518	P9983518	PLASTIC CONNECT C6-1/8"
519	PN11	HEX NUT 3/8"-24
520	P9983520	AIR EYELET (OUT) 3/8"
521	P9983521	BRASS NUT 3/8"-UNF
522	P9983522	BUSHING 10MM
523	P9983523	PLASTIC CONNECT 1/8" X 3/8"
524	P9983524	AIR VALVE 1/8"
525	P9983525	PLASTIC CONNECT L6-1/8"
526	P9983526	SOLENOID VALVE 1/8" X 220V
527	P9983527	PLASTIC CONNECT B6-1/8"
528	P9983528	PLASTIC CONNECT L6-1/8"
529	P9983529	SILENCER 1/8"
530	P9983530	CONNECTOR
531	PS25M	PHLP HD SCR M4-.7 X 35
532	PN04M	HEX NUT M4-.7
533	P9983533	PRESSURE GAUGE K-1000FR2
534	P9983534	PLASTIC CONNECT L6-1/4"
535	P9983535	AIR COCK 1/4" X 5/16"
536	PW03M	FLAT WASHER 6MM
537	PS14M	PHLP HD SCR M6-1.0 X 12
538	P9983538	TENSION CYLINDER 63 X 40ST
539	P9983539	PLASTIC CONNECT C6-1/8"
540	P9983540	SILENCER 1/4"

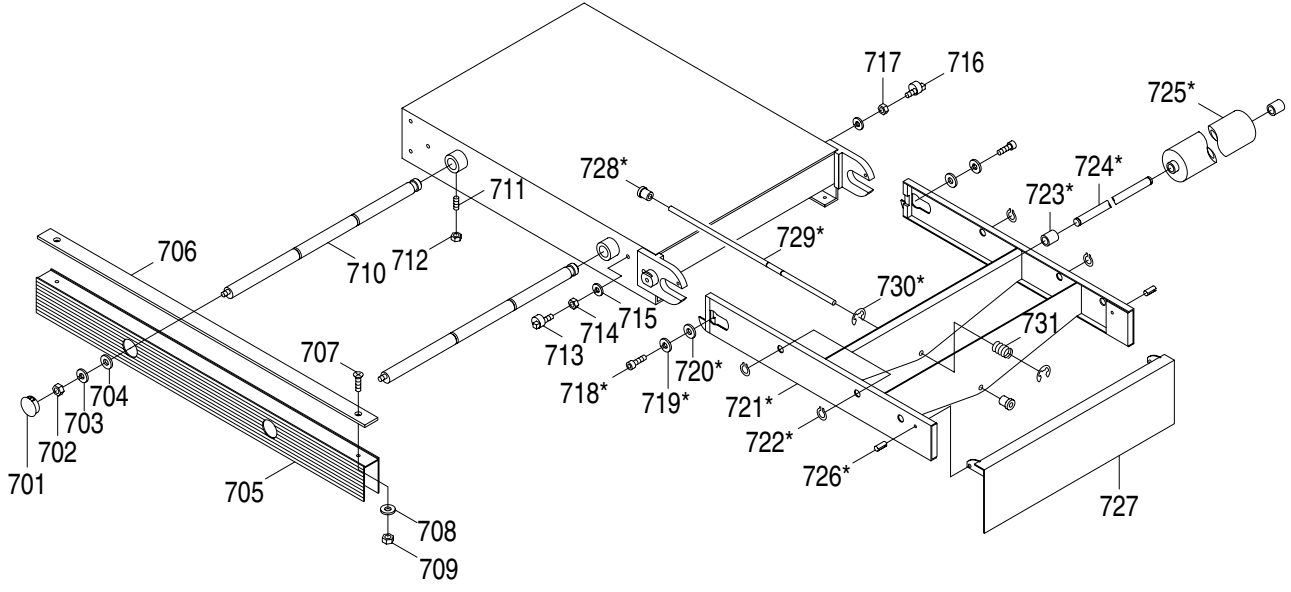
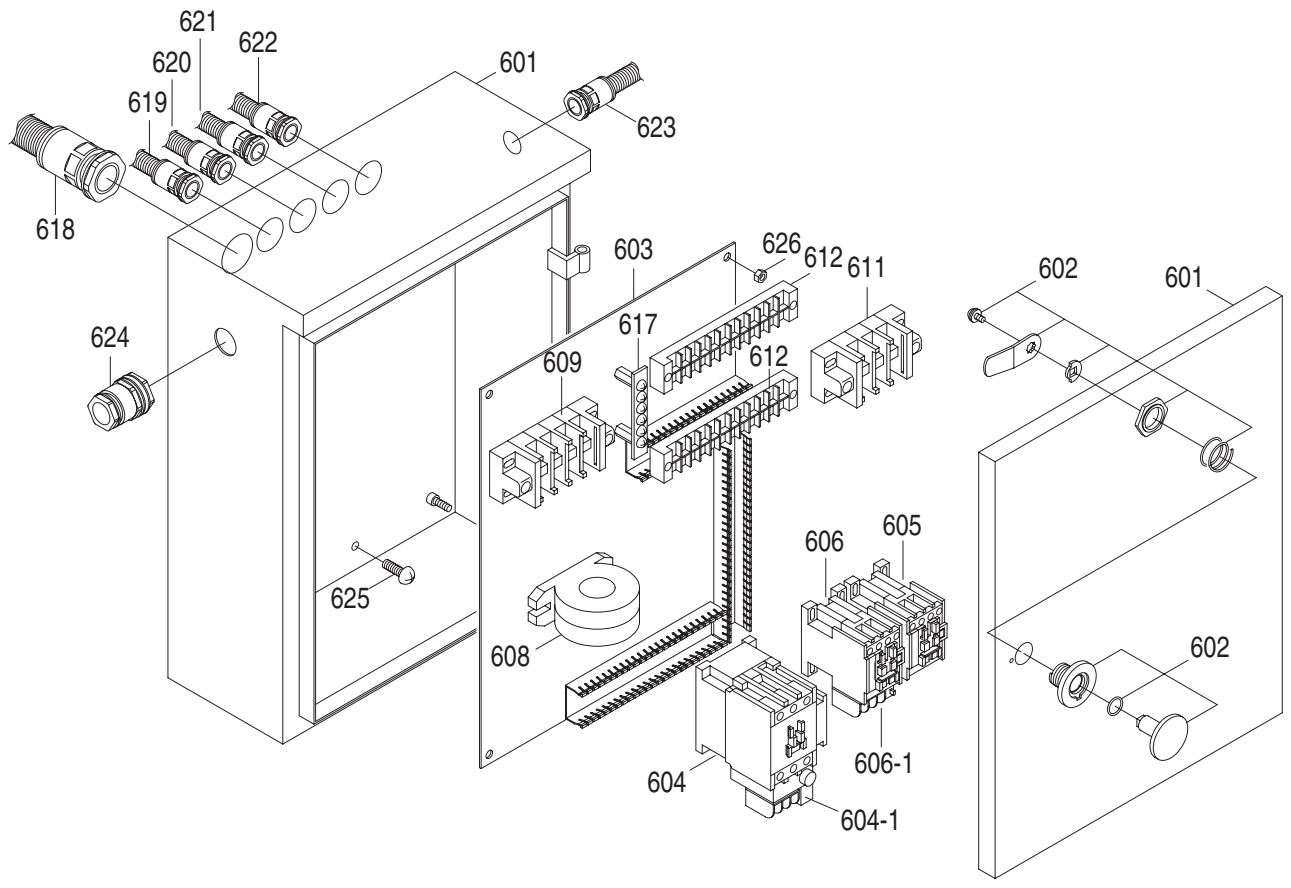

\* Optional Parts

REF	PART #	DESCRIPTION
601	P9983601	CONTROL BOX
602	P9983602	LOCK
603	P9983603	CONTROL PANEL
604	P9983604	CONTACTOR CN-25 SAND
604-1	P9983604-1	THERMAL RH 18/26
605	P9983605	CONTACTOR CN-11 MAIN
606	P9983606	CONTACTOR CN-11 FEED
606-1	P9983606-1	THERMAL RH 10E/1.7C
608	P9983608	CURRENT TRANSFORMER
609	P9983609	TERMINAL BOARD
611	P9983611	TERMINAL BOARD
612	P9983612	TERMINAL BOARD
617	P9983617	GROUND WIRE PANEL
618	P9983618	WIRE SLEEVE
619	P9983619	WIRE SLEEVE
620	P9983620	WIRE SLEEVE
621	P9983621	WIRE SLEEVE
622	P9983622	WIRE SLEEVE
623	P9983623	WIRE SLEEVE
624	P9983624	WIRE CONNECTOR (IN)
625	PS14M	PHLP HD SCR M6-1.0 X 12
626	PN01M	HEX NUT M6-1.0
701	P9983701	PLASTIC COVER
702	PN03M	HEX NUT M8-1.25
703	PLW04M	LOCK WASHER 8MM
704	PW01M	FLAT WASHER 8MM
705	P9983705	TABLE SUPPORT

REF	PART #	DESCRIPTION
706	P9983706	SUPPORT LINING
707	PS11M	PHLP HD SCR M6-1.0 X 16
708	PW03M	FLAT WASHER 6MM
709	PN01M	HEX NUT M6-1.0
710	P9983710	RETRACTABLE ROD
711	PSS10M	SETSCREW M10-1.5 X 20
712	PN02M	HEX NUT M10-1.5
713	P9983713	ECCENTRIC SHAFT LH
714	PN27M	HEX NUT LH M10-1.5
715	PLW06M	LOCK WASHER 10MM
716	P9983716	ECCENTRIC SHAFT RH
717	PN02M	HEX NUT M10-1.5
718	PSB62M	CAP SCREW M10-1.5 X 12
719	PLW06M	LOCK WASHER 10MM
720	PW04M	FLAT WASHER 10MM
721	P9983721	INFEED TABLE FRAME
722	PR47M	EXT RETAINING RING 13MM
723	P9983723	ROLLER BUSHING
724	P9983724	ROLLER SHAFT
725	P9983725	CONVEYOR ROLLER
726	PRP28M	PIN 5 X 40MM
727	P9983727	EMERGENCY BRAKE PANEL
728	P9983728	KNOB
729	P9983729	BRAKE ROD
730	PR39M	EXT RETAINING RING 8MM
731	P9983731	SPRING

# TROUBLESHOOTING

SYMPTOM	POSSIBLE CAUSE	CORRECTIVE ACTION
Motor will not start.	<ol style="list-style-type: none"> <li>1. Low voltage.</li> <li>2. Open circuit in motor or loose connections.</li> </ol>	<ol style="list-style-type: none"> <li>1. Check power line for proper voltage.</li> <li>2. Inspect all lead connections on motor for loose or open connections.</li> </ol>
Motor will not start; fuses or circuit breakers blow.	<ol style="list-style-type: none"> <li>1. Short circuit in line cord or plug.</li> <li>2. Short circuit in motor or loose connections.</li> <li>3. Incorrect fuses or circuit breakers in power line.</li> </ol>	<ol style="list-style-type: none"> <li>1. Inspect cord or plug for damaged insulation and shorted wires.</li> <li>2. Inspect all connections on motor for loose or shorted terminals or worn insulation.</li> <li>3. Install correct fuses or circuit breakers.</li> </ol>
Motor overheats.	<ol style="list-style-type: none"> <li>1. Motor overloaded.</li> <li>2. Air circulation through the motor restricted.</li> </ol>	<ol style="list-style-type: none"> <li>1. Reduce load on motor.</li> <li>2. Clean out motor to provide normal air circulation.</li> </ol>
Motor stalls (resulting in blown fuses or tripped circuit).	<ol style="list-style-type: none"> <li>1. Short circuit in motor or loose connections.</li> <li>2. Low voltage.</li> <li>3. Incorrect fuses or circuit breakers in power line.</li> <li>4. Motor overloaded.</li> </ol>	<ol style="list-style-type: none"> <li>1. Inspect connections on motor for loose or shorted terminals or worn insulation.</li> <li>2. Correct the low voltage conditions.</li> <li>3. Install correct fuses or circuit breakers.</li> <li>4. Reduce load on motor.</li> </ol>
Machine slows when operating.	<ol style="list-style-type: none"> <li>1. Feed rate too high.</li> <li>2. Depth of cut too great.</li> </ol>	<ol style="list-style-type: none"> <li>1. Feed workpiece slower and watch load meter.</li> <li>2. Reduce depth of cut and watch load meter.</li> </ol>
Loud, repetitious noise coming from machine	<ol style="list-style-type: none"> <li>1. Pulley set screws or keys are missing or loose.</li> <li>2. Motor fan is hitting the cover.</li> <li>3. V-belt is defective.</li> </ol>	<ol style="list-style-type: none"> <li>1. Inspect keys and set screws. Replace or tighten if necessary.</li> <li>2. Tighten fan or shim cover.</li> <li>3. Replace V-belt. See <i>Maintenance</i> section.</li> </ol>
Machine is loud, overheats or bogs down in the cut.	<ol style="list-style-type: none"> <li>1. Excessive depth of cut.</li> <li>2. Dull sanding belt.</li> </ol>	<ol style="list-style-type: none"> <li>1. Decrease depth of cut.</li> <li>2. Replace sanding belt.</li> </ol>
Edges of wood are rounded.	<ol style="list-style-type: none"> <li>1. Excessive depth of cut.</li> </ol>	<ol style="list-style-type: none"> <li>1. Reduce depth of cut.</li> </ol>
Uneven thickness from left to right of board.	<ol style="list-style-type: none"> <li>1. Feed table not parallel to sanding roller.</li> <li>2. Feed belt is worn.</li> </ol>	<ol style="list-style-type: none"> <li>1. Adjust the table.</li> <li>2. Replace feed belt.</li> </ol>
Workpiece slips on feed belt.	<ol style="list-style-type: none"> <li>1. Pressure rollers set too high.</li> <li>2. Dirty feed belt.</li> <li>3. Feed belt is worn.</li> </ol>	<ol style="list-style-type: none"> <li>1. Lower pressure rollers.</li> <li>2. Clean feed belt.</li> <li>3. Replace feed belt.</li> </ol>
Straight strip of notches on workpiece.	<ol style="list-style-type: none"> <li>1. Pressure rollers are dirty or damaged.</li> </ol>	<ol style="list-style-type: none"> <li>1. Clean or repair pressure rollers.</li> </ol>
Snake shaped marks on workpiece.	<ol style="list-style-type: none"> <li>1. Sanding belt damaged or dirty.</li> </ol>	<ol style="list-style-type: none"> <li>1. Clean or replace sanding belt.</li> </ol>

## WARNING

**For your safety, turn switch *OFF* and disconnect the machine from power source before any troubleshooting. Please refer to the adjustment section to make corrections.**

# TROUBLESHOOTING

SYMPTOM	POSSIBLE CAUSE	CORRECTIVE ACTION
Lines across width of workpiece.	1. Sanding belt seam is open or damaged.	1. Repair or replace sanding belt.
More material is removed from the end of workpiece than the length (snipe).	1. Workpiece is not supported as it comes out of sander. 2. Pressure rollers not set correctly.	1. Hold workpiece up with your hands as it comes out, or set up an out-feed table for your workpiece after it comes out. 2. Set pressure rollers as described in Section 8: Service Adjustments.
Glossy spots or streaks on workpiece.	1. Worn sanding belt. 2. Rear pressure roller too low.	1. Replace sanding belt. 2. Raise rear pressure roller. <b>(See warning in Pressure Roller section!)</b>
Sanding belt clogs quickly.	1. Sanding belt grit too small for particular job. 2. Excessive depth of cut. 3. Wood is too moist.	1. Replace with a coarser grit sanding belt. 2. Reduce depth of cut. 3. Allow wood to dry out.
Sanding belt does not tension correctly; rollers slip under belt.	1. Low air pressure. 2. Air leaks in system.	1. Adjust air pressure to 75 PSI at primary regulator. 2. Inspect all hoses and connections for leaking air; use water on suspected area to detect bubbles.
Sanding belt runs off to one side, stopping the sander.	1. Air eye fork clogged. 2. Oscillation return valve closed. 3. Oscillation timing incorrect.	1. Clean the intake hole on the air eye fork. 2. Open valve. 3. Adjust oscillation timing.
Sanding belt will not start.	1. Sanding belt is not tensioned. 2. Limit switches engaged. 3. Emergency stop plate engaged.	1. Tension sanding belt. 2. Center sanding belt so it is not touching the limit switches. 3. Make sure emergency stop switch is released.
Poor, non-aggressive sanding results.	1. Platen adjusted incorrectly, above bottom surface level of lower sanding rollers. 2. Sanding belt loaded with sawdust. 3. Sanding belt worn out.	1. Adjust platen on the same plane as, or lower than, bottom surface level of lower rollers. 2. Clean sanding belt to unload sawdust. 3. Replace sanding belt with a new one.
Conveyor belt not tracking in center.	1. Conveyor rollers moved out of adjustment.	1. Re-adjust conveyor rollers.
Conveyor belt slipping.	1. Conveyor rollers have incorrect tension. 2. Conveyor rollers contaminated with dirt or dust.	1. Adjust conveyor rollers to increase tension. 2. Clean conveyor rollers.
Emergency brake stops slow.	1. Air pressure incorrect. 2. Air leak in system. 3. Brake rotor contaminated with oil. 4. Brake pads worn out.	1. Adjust air pressure to 75 PSI. 2. Find and fix air leaks. 3. Clean brake rotor with automotive brake parts cleaner. 4. Replace brake pads.
Grinding noise when braking.	1. Brakes severely worn out.	1. Replace brake pads, have rotor turned (possibly replaced).

## WARNING

For your safety, turn switch **OFF** and disconnect the machine from power source before any troubleshooting. Please refer to the adjustment section to make corrections.

# WARRANTY AND RETURNS

---

---

Grizzly Industrial, Inc. warrants every product it sells for a period of **1 year** to the original purchaser from the date of purchase. This warranty does not apply to defects due directly or indirectly to misuse, abuse, negligence, accidents, repairs or alterations or lack of maintenance. This is Grizzly's sole written warranty and any and all warranties that may be implied by law, including any merchantability or fitness, for any particular purpose, are hereby limited to the duration of this written warranty. We do not warrant or represent that the merchandise complies with the provisions of any law or acts unless the manufacturer so warrants. In no event shall Grizzly's liability under this warranty exceed the purchase price paid for the product and any legal actions brought against Grizzly shall be tried in the State of Washington, County of Whatcom.

We shall in no event be liable for death, injuries to persons or property or for incidental, contingent, special, or consequential damages arising from the use of our products.

To take advantage of this warranty, contact us by mail or phone and give us all the details. We will then issue you a "Return Number," which must be clearly posted on the outside as well as the inside of the carton. We will not accept any item back without this number. Proof of purchase must accompany the merchandise.

The manufacturers reserve the right to change specifications at any time because they constantly strive to achieve better quality equipment. We make every effort to ensure that our products meet high quality and durability standards and we hope you never need to use this warranty.

Please feel free to write or call us if you have any questions about the machine or the manual.

Thank you again for your business and continued support. We hope to serve you again soon.



# WARRANTY CARD

Name \_\_\_\_\_  
Street \_\_\_\_\_  
City \_\_\_\_\_ State \_\_\_\_\_ Zip \_\_\_\_\_  
Phone Number \_\_\_\_\_ E-Mail \_\_\_\_\_ FAX \_\_\_\_\_  
MODEL # \_\_\_\_\_ Serial# \_\_\_\_\_ Order# \_\_\_\_\_

The following information is given on a voluntary basis. It will be used for marketing purposes to help us develop better products and services. Of course, all information is strictly confidential.

- How did you learn about us?  
 Advertisement                       Friend  
 Catalog                                 Card Deck  
 World Wide Web  
 Other \_\_\_\_\_
- Which of the following magazines do you subscribe to.  
 American Woodworker             Practical Homeowner  
 Cabinetmaker                         Shop Notes  
 Family Handyman                  Today's Homeowner  
 Fine Homebuilding                 WOOD  
 Fine Woodworking                  WoodenBoat  
 Home Handyman                     Woodshop News  
 Journal of Light Construction     Woodsmith  
 Old House Journal                  Woodwork  
 Popular Mechanics                  Woodworker  
 Popular Science                     Woodworker's Journal  
 Popular Woodworking              Workbench  
 Other \_\_\_\_\_
- Which of the following woodworking/remodeling shows do you watch?  
 Backyard America                  The New Yankee Workshop  
 Home Time                             This Old House  
 The American Woodworker        Woodwright's Shop  
 Other \_\_\_\_\_
- What is your annual household income?  
 \$20,000-\$29,999                     \$60,000-\$69,999  
 \$30,000-\$39,999                     \$70,000-\$79,999  
 \$40,000-\$49,999                     \$80,000-\$89,999  
 \$50,000-\$59,999                     \$90,000 +
- What is your age group?  
 20-29                                     50-59  
 30-39                                     60-69  
 40-49                                     70 +
- How long have you been a woodworker?  
 0 - 2 Years                             8 - 20 Years  
 2 - 8 Years                             20+ Years
- How would you rank your woodworking skills?  
 Simple                                     Advanced  
 Intermediate                             Master Craftsman
- What stationary woodworking tools do you own? Check all that apply.  
 Air Compressor                       Panel Saw  
 Band Saw                                 Planer  
 Drill Press                               Power Feeder  
 Wide-belt Sander                       Radial Arm Saw  
 Dust Collector                         Shaper  
 Horizontal Boring Machine          Spindle Sander  
 Jointer                                   Table Saw  
 Lathe                                       Vacuum Veneer Press  
 Mortiser                                  Wide Belt Sander  
 Other \_\_\_\_\_
- How many of your woodworking machines are Grizzly? \_\_\_\_\_
- Which benchtop tools do you own? Check all that apply.  
 1" x 42" Belt Sander                  6" - 8" Grinder  
 5" - 8" Drill Press                     Mini Lathe  
 8" Table Saw                           10" - 12" Thickness Planer  
 8" - 10" Bandsaw                     Scroll Saw  
 Disc/Belt Sander                       Spindle/Belt Sander  
 Mini Jointer  
 Other \_\_\_\_\_
- How many of the machines checked above are Grizzly? \_\_\_\_\_
- Which portable/hand held power tools do you own? Check all that apply.  
 Belt Sander                             Orbital Sander  
 Biscuit Joiner                         Palm Sander  
 Circular Saw                           Portable Planer  
 Detail Sander                          Saber Saw  
 Drill/Driver                             Reciprocating Saw  
 Miter Saw                               Router  
 Other \_\_\_\_\_
- What machines/supplies would you like Grizzly Industrial to carry?  
\_\_\_\_\_  
\_\_\_\_\_  
\_\_\_\_\_
- What new accessories would you like Grizzly Industrial to carry?  
\_\_\_\_\_  
\_\_\_\_\_  
\_\_\_\_\_
- What other companies do you purchase your tools and supplies from?  
\_\_\_\_\_  
\_\_\_\_\_  
\_\_\_\_\_
- Do you think your purchase represents good value?  
 Yes                                         No
- Would you recommend Grizzly Imports to a friend?  
 Yes                                         No
- Would you allow us to use your name as a reference for Grizzly customers in your area? **Note: We never use names more than three times.**  
 Yes                                         No
- Comments: \_\_\_\_\_  
\_\_\_\_\_  
\_\_\_\_\_  
\_\_\_\_\_

CUT ALONG DOTTED LINE

FOLD ALONG DOTTED LINE

---

---

---



Place  
Stamp  
Here



**GRIZZLY INDUSTRIAL, INC.  
P.O. BOX 2069  
BELLINGHAM, WA 98227-2069**



FOLD ALONG DOTTED LINE

Send a Grizzly Catalog to a friend:

Name _____
Street _____
City _____ State _____ Zip _____

TAPE ALONG EDGES--PLEASE DO NOT STAPLE



# *grizzly.com*

**TOOL WEBSITE**

Buy Direct and Save with Grizzly® – Trusted, Proven and a Great Value!

*Visit Our Website Today And Discover Why  
Grizzly® Is The Industry Leader!*

- SECURE ORDERING
- ORDERS SHIPPED WITHIN 24 HOURS
- E-MAIL RESPONSE WITHIN ONE HOUR

-OR-

Call Today For A **FREE**  
Full Color Catalog

**1-800-523-4777**



## Free Manuals Download Website

<http://myh66.com>

<http://usermanuals.us>

<http://www.somanuals.com>

<http://www.4manuals.cc>

<http://www.manual-lib.com>

<http://www.404manual.com>

<http://www.luxmanual.com>

<http://aubethermostatmanual.com>

Golf course search by state

<http://golfingnear.com>

Email search by domain

<http://emailbydomain.com>

Auto manuals search

<http://auto.somanuals.com>

TV manuals search

<http://tv.somanuals.com>