

Grizzly **Industrial, Inc.**®

16" BANDSAW **MODEL G1073/G1073Z** **INSTRUCTION MANUAL**

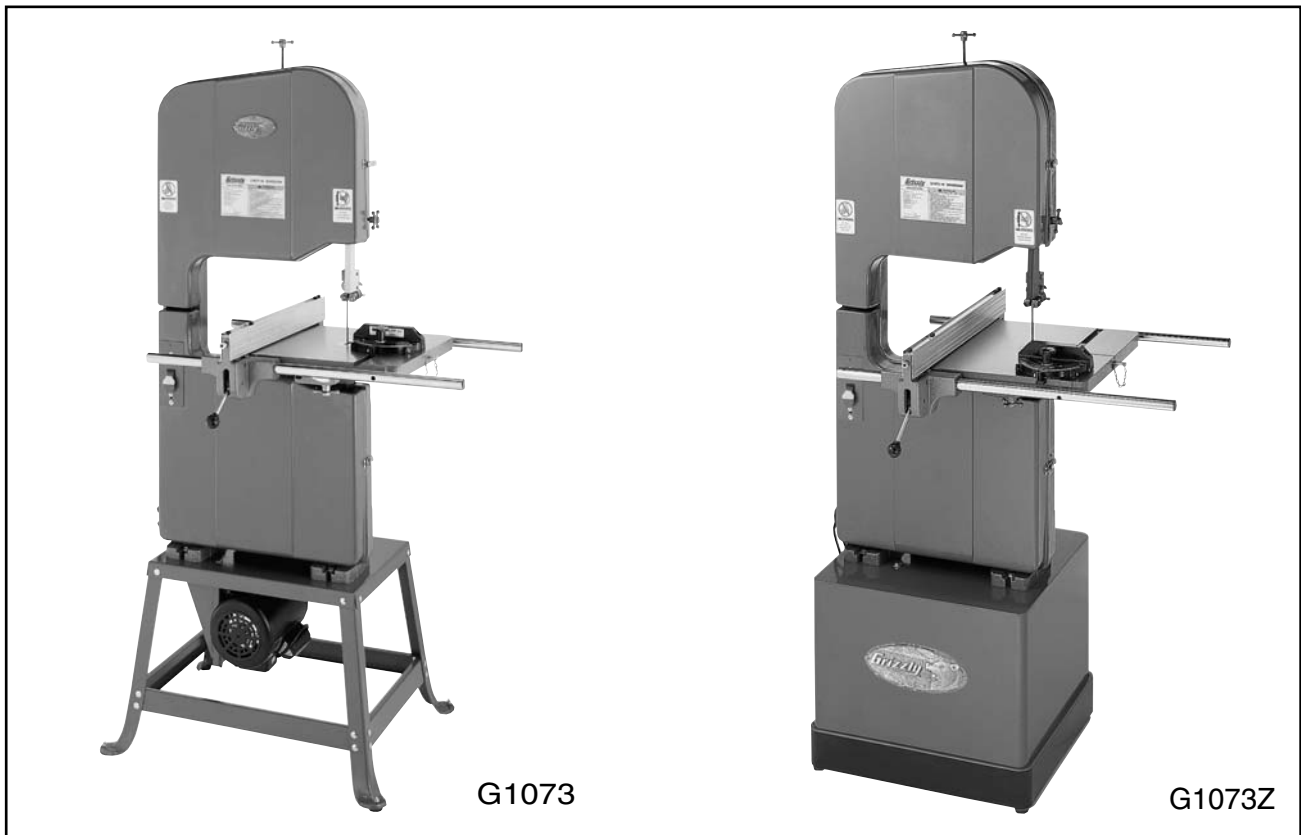

COPYRIGHT © 1993 BY GRIZZLY INDUSTRIAL, INC. REG #TX 3 562 349
**WARNING: NO PORTION OF THIS MANUAL MAY BE REPRODUCED IN ANY SHAPE
OR FORM WITHOUT THE WRITTEN APPROVAL OF GRIZZLY INDUSTRIAL, INC.**
REVISED OCTOBER, 2002. PRINTED IN TAIWAN

ONLINE MANUAL DISCLAIMER

THE INFORMATION IN THIS MANUAL REPRESENTS THE CONFIGURATION OF THE MACHINE AS IT IS CURRENTLY BEING SHIPPED. THE MACHINE CONFIGURATION CAN CHANGE AS PRODUCT IMPROVEMENTS ARE INCORPORATED. IF YOU OWN AN EARLIER VERSION OF THE MACHINE, THIS MANUAL MAY NOT EXACTLY DEPICT YOUR MACHINE. CONTACT CUSTOMER SERVICE IF YOU HAVE ANY QUESTIONS ABOUT DIFFERENCES. PREVIOUS VERSIONS ARE NOT AVAILABLE ONLINE.

WARNING

Some dust created by power sanding, sawing, grinding, drilling, and other construction activities contains chemicals known to the State of California to cause cancer, birth defects or other reproductive harm. Some examples of these chemicals are:

- Lead from lead-based paints.
- Crystalline silica from bricks, cement, and other masonry products.
- Arsenic and chromium from chemically treated lumber.

Your risk from these exposures varies, depending on how often you do this type of work. To reduce your exposure to these chemicals: work in a well ventilated area, and work with approved safety equipment, such as those dust masks that are specially designed to filter out microscopic particles.

Table Of Contents

	PAGE
1. SAFETY	2
SAFETY RULES FOR ALL TOOLS	2-3
ADDITIONAL SAFETY INSTRUCTIONS FOR BANDSAWS	4
2. CIRCUIT REQUIREMENTS	5
220V OPERATION	5
110V OPERATION	5
EXTENSION CORDS	5
GROUNDING	6
3. GENERAL INFORMATION	7
UNPACKING	8
PIECE INVENTORY	8
CLEAN UP	9
SITE CONSIDERATIONS	9
4. ASSEMBLY	10
STAND	10-11
BANDSAW TO STAND	11
WIRING THE MOTOR	12
V-BELT	12-13
WORKING TABLE	14
FENCE	15
GUARD	16
DUST PORT	16
5. ADJUSTMENTS	17
BLADE TENSION	17
BLADE TRACKING	17-18
BLADE GUIDES	18-19
TABLE STOP	19-20
TABLE PARALLELISM	20
TABLE TILT	20
BLADE CHANGES	21
GUIDE POST	22-23
FENCE ADJUSTMENT	23-24
BLADE LEAD	24-25
WHEEL ALIGNMENT	25-26
6. OPERATIONS	27
TEST RUN	27
BLADE SELECTIONS	27
CUTTING CURVES	28
RESAWING	28
7. MAINTENANCE	29
V-BELTS	29
MISCELLANEOUS	29
TABLE	29
LUBRICATION	29
8. CLOSURE	30
WIRE DIAGRAM	31
MACHINE DATA	32
PARTS BREAKDOWN AND PARTS LISTS	33-40
TROUBLESHOOTING GUIDE	41
WARRANTY AND RETURNS	42

SECTION 1: SAFETY

WARNING

For Your Own Safety Read Instruction Manual Before Operating This Equipment

The purpose of safety symbols is to attract your attention to possible hazardous conditions. This manual uses a series of symbols and signal words which are intended to convey the level of importance of the safety messages. The progression of symbols is described below. Remember that safety messages by themselves do not eliminate danger and are not a substitute for proper accident prevention measures.

 **DANGER** Indicates an imminently hazardous situation which, if not avoided, **WILL** result in death or serious injury.

 **WARNING** Indicates a potentially hazardous situation which, if not avoided, **COULD** result in death or serious injury.

 **CAUTION** Indicates a potentially hazardous situation which, if not avoided, **MAY** result in minor or moderate injury. It may also be used to alert against unsafe practices.

NOTICE This symbol is used to alert the user to useful information about proper operation of the equipment.

WARNING

Safety Instructions For Power Tools

1. **KEEP GUARDS IN PLACE** and in working order.
2. **REMOVE ADJUSTING KEYS AND WRENCHES.** Form habit of checking to see that keys and adjusting wrenches are removed from tool before turning on.
3. **KEEP WORK AREA CLEAN.** Cluttered areas and benches invite accidents.
4. **DO NOT USE IN DANGEROUS ENVIRONMENT.** Do not use power tools in damp or wet locations, or where any flammable or noxious fumes may exist. Keep work area well lighted.
5. **KEEP CHILDREN AND VISITORS AWAY.** All children and visitors should be kept a safe distance from work area.
6. **MAKE WORKSHOP CHILD PROOF** with padlocks, master switches, or by removing starter keys.
7. **DO NOT FORCE TOOL.** It will do the job better and safer at the rate for which it was designed.
8. **USE RIGHT TOOL.** Do not force tool or attachment to do a job for which it was not designed.

WARNING

Safety Instructions For Power Tools

- 9. USE PROPER EXTENSION CORD.** Make sure your extension cord is in good condition. Conductor size should be in accordance with the chart below. The amperage rating should be listed on the motor or tool nameplate. An undersized cord will cause a drop in line voltage resulting in loss of power and overheating. Your extension cord must also contain a ground wire and plug pin. Always repair or replace extension cords if they become damaged.

Minimum Gauge for Extension Cords

AMP RATING	LENGTH		
	25ft	50ft	100ft
0-6	18	16	16
7-10	18	16	14
11-12	16	16	14
13-16	14	12	12
17-20	12	12	10
21-30	10	10	No

- 10. WEAR PROPER APPAREL.** Do not wear loose clothing, gloves, neckties, rings, bracelets, or other jewelry which may get caught in moving parts. Non-slip footwear is recommended. Wear protective hair covering to contain long hair.
- 11. ALWAYS USE SAFETY GLASSES.** Also use face or dust mask if cutting operation is dusty. Everyday eyeglasses only have impact resistant lenses, they are NOT safety glasses.
- 12. SECURE WORK.** Use clamps or a vise to hold work when practical. It is safer than using your hand and frees both hands to operate tool.
- 13. DO NOT OVERREACH.** Keep proper footing and balance at all times.
- 14. MAINTAIN TOOLS WITH CARE.** Keep tools sharp and clean for best and safest performance. Follow instructions for lubricating and changing accessories.

- 15. USE RECOMMENDED ACCESSORIES.** Consult the owner's manual for recommended accessories. The use of improper accessories may cause risk of injury.

- 16. REDUCE THE RISK OF UNINTENTIONAL STARTING.** On machines with magnetic contact starting switches there is a risk of starting if the machine is bumped or jarred. Always disconnect from power source before adjusting or servicing. Make sure switch is in OFF position before reconnecting.

- 17. MANY WOODWORKING TOOLS CAN "KICKBACK" THE WORKPIECE** toward the operator if not handled properly. Know what conditions can create "kickback" and know how to avoid them. Read the manual accompanying the machine thoroughly.

- 18. CHECK DAMAGED PARTS.** Before further use of the tool, a guard or other part that is damaged should be carefully checked to determine that it will operate properly and perform its intended function. Check for alignment of moving parts, binding of moving parts, breakage of parts, mounting, and any other conditions that may affect its operation. A guard or other part that is damaged should be properly repaired or replaced.

- 19. NEVER LEAVE TOOL RUNNING UNATTENDED. TURN POWER OFF.** Do not leave tool until it comes to a complete stop.

- 20. NEVER OPERATE A MACHINE WHEN TIRED, OR UNDER THE INFLUENCE OF DRUGS OR ALCOHOL.** Full mental alertness is required at all times when running a machine.

- 21. NEVER ALLOW UNSUPERVISED OR UNTRAINED PERSONNEL TO OPERATE THE MACHINE.** Make sure any instructions you give in regards to the operation of the machine are approved, correct, safe, and clearly understood.

WARNING

Additional Safety Instructions For Bandsaws

- 1. DO NOT OPERATE WITH DULL OR BADLY WORN BLADES.** Dull blades require more effort to use and are difficult to control. Inspect blades before each use.
- 2. NEVER POSITION FINGERS OR THUMBS IN LINE WITH THE CUT.** Serious personal injury could occur.
- 3. DO NOT OPERATE THIS BANDSAW WITHOUT WHEEL, PULLEY, AND BLADE GUARDS IN PLACE.**
- 4. WHEN REPLACING BLADES,** make sure teeth face down toward the table. The force of the cut is always down. Make sure the blade is properly tensioned.
- 5. CUTS SHOULD ALWAYS BE FULLY SUPPORTED** by the table or some type of support fixture. Always support round stock in a V-block.
- 6. DO NOT BACK WORKPIECE AWAY** from the blade while the saw is running. Plan your cuts so you always cut out of the wood. If you need to back the work out, turn the bandsaw off and wait for the blade to come to a complete stop. Do not twist or put excessive stress on the blade while backing work away.
- 7. ALWAYS FEED STOCK EVENLY AND SMOOTHLY.** Do not force or twist blade while cutting, especially when sawing small radii.
- 8. THIS MACHINE IS NOT DESIGNED TO CUT METAL** or other material except wood.
- 9. BLADE SHOULD BE RUNNING AT FULL SPEED** before beginning a cut.
- 10. DO NOT MANUALLY STOP OR SLOW BLADE** after turning the saw off. Allow it to come to a complete stop before you leave it unattended.
- 11. ALL INSPECTIONS, ADJUSTMENTS, AND MAINTENANCE ARE TO BE DONE WITH THE POWER OFF** and the plug pulled from the outlet. Wait for all moving parts to come to a complete stop.
- 12. HABITS – GOOD AND BAD – ARE HARD TO BREAK.** Develop good habits in your shop and safety will become second-nature to you.
- 13. IF AT ANY TIME YOU ARE EXPERIENCING DIFFICULTIES PERFORMING THE INTENDED OPERATION, STOP USING THE BANDSAW!** Then contact our service department or ask a qualified expert how the operation should be performed.

WARNING

Like all power tools, there is danger associated with bandsaws. Accidents are frequently caused by lack of familiarity or failure to pay attention. Use this tool with respect and caution to lessen the possibility of operator injury. If normal safety precautions are overlooked or ignored, serious personal injury may occur.

CAUTION

No list of safety guidelines can be complete. Every shop environment is different. Always consider safety first, as it applies to your individual working conditions. Use this and other machinery with caution and respect. Failure to do so could result in serious personal injury, damage to equipment or poor work results.

SECTION 2: CIRCUIT REQUIREMENTS

220V Operation

The Model G1073/G1073Z Bandsaw is supplied with a dual-voltage 110V/220V motor, prewired for 220V operation. Under normal use, the motor draws approximately 12 amps at 220V. We recommend a 15 amp circuit breaker or slow-blow fuse for 220V. This should be satisfactory for normal use, while providing enough protection against damage caused by an overloaded circuit. If frequent circuit failures occur when using the bandsaw, contact our service department or your local electrical contractor.

The Model G1073/G1073Z Bandsaw is not supplied with a power plug. We recommend using a NEMA-style L6-15 plug and outlet similar to the one shown in **Figure 1**. You may also “hard-wire” the bandsaw directly to your panel, provided you place a disconnect near the machine.

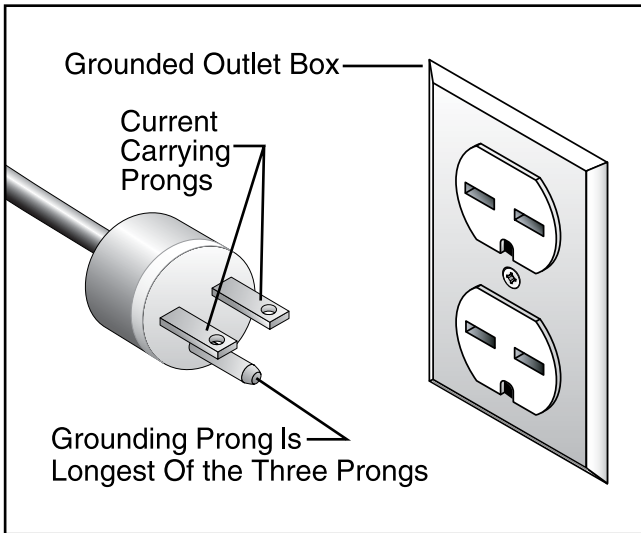

Figure 1. Typical 220V 3-prong plug and outlet.

⚠ CAUTION

Be sure that your particular electrical configuration complies with local and state codes. The best way to ensure compliance is to check with your local municipality or licensed electrician.

110V Operation

If 110 volt operation is desired, refer to the wiring diagram in the back of this manual. Under normal use, the motor draws approximately 24 amps at 110V. We recommend using a circuit breaker and wires rated for 30 amps. This should be satisfactory for normal use, while providing enough protection against damage caused by power surges. If frequent circuit failures occur when using the bandsaw, contact our service department or your local electrical contractor.

The Model G1073/G1073Z is not supplied with a power plug. It will be necessary to supply your own standard 110V, 30 Amp grounded plug and receptacle as shown in **Figure 2**.



Extension Cords

We do not recommend the use of extension cords on 220V equipment. It is much better to arrange the placement of your equipment and the installed wiring to eliminate the need for extension cords. Should it be necessary to use an extension, make sure the cord is rated Hard Service (Grade S) or better. Refer to the chart on page 3 to determine the minimum gauge for the extension cord. The extension cord must also contain a ground wire and plug pin. Always repair or replace extension cords when they become worn or damaged.



Grounding

In the event of a malfunction or breakdown, grounding provides a path of least resistance for electric current to reduce the risk of electric shock. This tool is equipped with an electric cord having an equipment grounding conductor. A plug with a grounding pin must be plugged into a matching outlet that is properly installed and grounded in accordance with all local codes and ordinances.

Improper connections of the electrical-grounding conductor can result in risk of electric shock. The conductor with green or green and yellow striped insulation is the electrical grounding conductor. If repair or replacement of the electric cord or plug is necessary, do not connect the equipment grounding conductor to a live terminal.

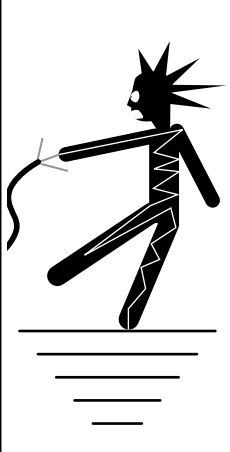
	<p>⚠ WARNING This equipment must be grounded. Verify that any existing electrical outlet and circuit you intend to plug into is actually grounded. Under no circumstances should the grounding pin from any three-pronged plug be removed. Serious injury may occur.</p>
--	---

<p>⚠ CAUTION We have covered some basic electrical requirements for the safe operation of your bandsaw. These requirements are not necessarily comprehensive. You must be sure that your particular electrical configuration complies with local and state codes. Ensure compliance by checking with your local municipality or a licensed electrician.</p>
--

Under no circumstances should the grounding pin from any three-pronged plug be removed. If it will not fit the outlet, have the proper outlet installed by a qualified electrician.

Check with a qualified electrician or one of our service personnel if the grounding instructions are not completely understood, or if you are in doubt as to whether the tool is properly grounded. Use only 3-wire extension cords that have 3-prong grounding type plugs and 3-hole receptacles that accept the tool's plug, similar to that in **Figure 2.**

Repair or replace damaged or worn cords immediately.

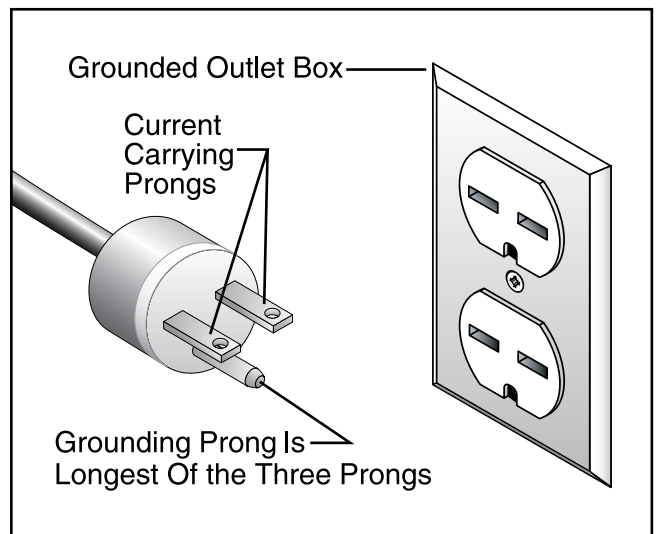
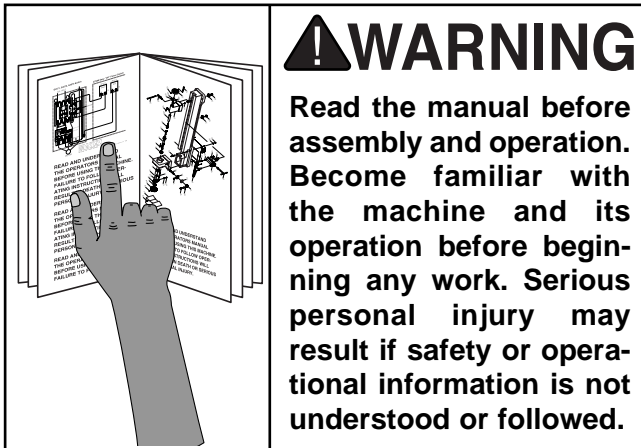

Figure 2.



SECTION 3: GENERAL INFORMATION



!WARNING

Read the manual before assembly and operation. Become familiar with the machine and its operation before beginning any work. Serious personal injury may result if safety or operational information is not understood or followed.

Grizzly Industrial, Inc. is proud to offer the Model G1073 and G1073Z 16" Bandsaws. These bandsaws are a part of Grizzly's growing family of fine woodworking machinery. When used according to the guidelines stated in this manual, you can expect years of trouble-free, enjoyable operation, and proof of Grizzly's commitment to customer satisfaction.

The Models G1073 and G1073Z are essentially the same machine with the exception of the different style stands. Both feature a cast iron, one-piece body, 3 speed pulley system, and a 7³/₄" cutting height. Also included are a fence, miter gauge, guards, and 1/2" blade. The saw is equipped with a 1725 R.P.M., 2 H.P. motor. The Model G1073 comes with an open stand, and the Model G1073Z comes with a cabinet stand.

We are also pleased to provide this manual with the Model G1073/G1073Z. It was written to guide you through assembly, review safety considerations, and cover general operating procedures. It represents our latest effort to produce the best documentation possible. If you have any comments or criticisms that you feel we should address in our next printing, please write to us at:

Grizzly Industrial, Inc.
% Technical Documentation
P.O. Box 2069
Bellingham, WA 98227

Most important, we stand behind our machines. If you have any service questions or parts requests, please call or write us at the location listed below.

Grizzly Industrial, Inc.
1203 Lycoming Mall Circle
Muncy, PA 17756
Phone: (570) 546-9663
Fax: (800) 438-5901
E-Mail: techsupport@grizzly.com
Web Site: <http://www.grizzly.com>

The specifications, drawings, and photographs illustrated in this manual represent the Model G1073/G1073Z as supplied when the manual was prepared. However, owing to Grizzly's policy of continuous improvement, changes may be made at any time with no obligation on the part of Grizzly. However, we always keep current Grizzly manuals available on our website at www.grizzly.com. Any updates in your machine will be reflected in these manuals as soon as they are complete.



Unpacking

The Model G1073 Bandsaw is shipped from the manufacturer in a carefully packed carton, and the Model G1073Z is shipped in two cartons. If you discover the machine is damaged after you have signed for delivery, *please call Customer Service immediately for advice.*

Save the containers and all packing materials for possible inspection by the carrier or its agent. *Otherwise filing a freight claim can be difficult.*

When you are completely satisfied with the condition of your shipment, you should inventory its parts.



⚠️ WARNING
The Model G1073/G1073Z is a heavy machine (456 lbs. shipping weight). **DO NOT over-exert yourself while unpacking or moving your machine – get assistance.**

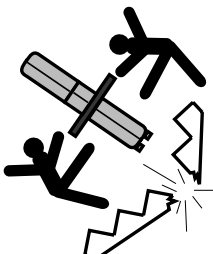

⚠️ WARNING
If moving this machine up or down stairs, the machine must be dismantled and moved in smaller pieces. Make sure the stairs are capable of supporting the combined weight of the machine parts and the people moving them.



⚠️ CAUTION
Some metal parts may have sharp edges on them after they are formed. Please examine the edges of all metal parts before handling them. Failure to do so could result in injury.



Piece Inventory

After all the parts have been removed from the carton, you should have:

- Bandsaw Unit with Blade
- Motor
- Stand Parts (1073)
- Cabinet Stand (1073Z)
- Table Support Bracket
- Miter Gauge
- Table
- Mounting Bracket
- Fence
- V-Belt
- Pulley Guard
- Dust Port

Hardware	Qty
Carriage Bolts $\frac{5}{16}$ "-18 x $\frac{5}{8}$ " (does not apply for G1073Z)	24
Hex Bolts $\frac{1}{4}$ "-20 x $\frac{3}{4}$ "	2
Hex Bolts $\frac{5}{16}$ "-18 x 1"	4
Carriage Bolts $\frac{5}{16}$ "-18 x 1" (does not apply for G1073Z)	4
Hex Bolts $\frac{3}{8}$ "-16 x 1"	2
Hex Bolts $\frac{3}{8}$ "-16 x 2"	4
Hex Nuts $\frac{1}{4}$ "-20	2
Hex Nuts $\frac{5}{16}$ "-18 (4 for G1073Z)	32
Hex Nuts $\frac{3}{8}$ "-16 (4 for G1073Z)	6
Flat Washers $\frac{5}{16}$ " (4 for G1073Z)	32
Anti Vibration Pads	4
Flat Washers $\frac{3}{8}$ " (8 for G1073Z)	12
Cap Screws $\frac{1}{4}$ "-20 x $1\frac{1}{4}$ "	4
Fence Rail Spacers	4
Flat Washers $\frac{1}{4}$ "	4

In the event that any non-proprietary parts are missing (e.g. nuts or washers), we would be glad to replace them, or for the sake of expediency, replacements can be obtained at your local hardware store.



Clean up

The unpainted surfaces are coated with a waxy oil to protect them from corrosion during shipment. Remove this protective coating with a solvent cleaner or citrus-based degreaser such as Grizzly's G7895 Degreaser. Avoid chlorine-based solvents as they may damage painted surfaces should they come in contact. Always follow the usage instructions on the product you choose for clean up.

	<p>⚠ WARNING Do not use gasoline or other petroleum-based solvents to clean with. They have a low flash point which makes them extremely flammable. A risk of explosion and burning exists if these products are used. Serious personal injury may occur.</p>
---	--

	<p>⚠ WARNING Do not smoke while using solvents. A risk of explosion or fire exists and may result in serious personal injury.</p>
---	--

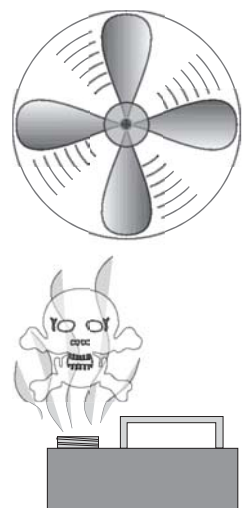
	<p>⚠ CAUTION Many of the solvents commonly used to clean machinery can be toxic when inhaled or ingested. Always work in well-ventilated areas far from potential ignition sources when dealing with solvents. Use care when disposing of waste rags and towels to be sure they do not create fire or environmental hazards.</p>
---	---



Site Considerations

- 1. Floor Load:** Your Model G1073/G1073Z 16" Bandsaw represents a large weight load in a small footprint. Most commercial floors are suitable for the Model G1073/G1073Z. Some residential floors may require additional build up to support both machine and operator.
- 2. Working Clearances:** Consider existing and anticipated needs, size of material to be processed through each machine, and space for auxiliary stands, work tables or other machinery when establishing a location for your bandsaw.
- 3. Lighting and Outlets:** Lighting should be bright enough to eliminate shadow and prevent eye strain. Electrical circuits should be dedicated or large enough to handle amperage requirements. Outlets should be located near each machine so power or extension cords are clear of high-traffic areas. Observe local electrical codes for proper installation of new lighting, outlets, or circuits.

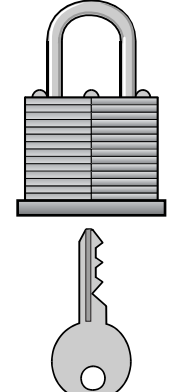
	<p>⚠ CAUTION Make your shop "child safe." Ensure that your workplace is inaccessible to children by closing and locking all entrances when you are away. Never allow visitors in your shop when assembling, adjusting, or operating equipment.</p>
--	---



SECTION 4: ASSEMBLY

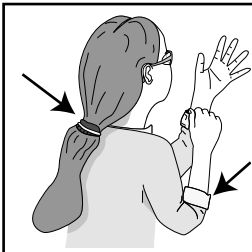

⚠ WARNING
Keep loose clothing rolled up and out of the way of machinery and keep hair pulled back.

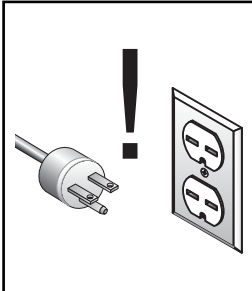

⚠ WARNING
Disconnect power to the machine when performing any maintenance or assembly. Failure to do this may result in serious personal injury.

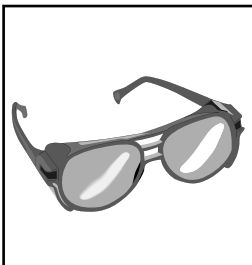

⚠ WARNING
Wear safety glasses during the entire assembly process. Failure to comply may result in serious personal injury.

Stand (G1073)

The stand assembly on the Model G1073 is shown here. If you have the Model G1073Z, follow the same instructions for mounting the motor, bandsaw to stand, and the anti-vibration pads. Disregard the steps that do not apply.

To ease assembly, build the stand upside down on a bench, then place it upright on the floor. Do not fully tighten any of the bolts until directed to do so in the next section.

Sometimes sheet metal parts have a tendency to "spring" after they are formed. For this reason, you may need to use a little extra force to align holes to insert bolts.

To assemble the stand:

1. Flip the top of the stand upside-down. Position the motor mounting bracket so that it sits over the four (4) evenly spaced holes in the top. Bolt the bracket to the stand with two (2) $\frac{3}{8}$ "-16 x 1" hex bolts, $\frac{3}{8}$ " washers, and $\frac{3}{8}$ "-16 nuts provided. Hand tighten for now so your assembly looks like **Figure 3**.

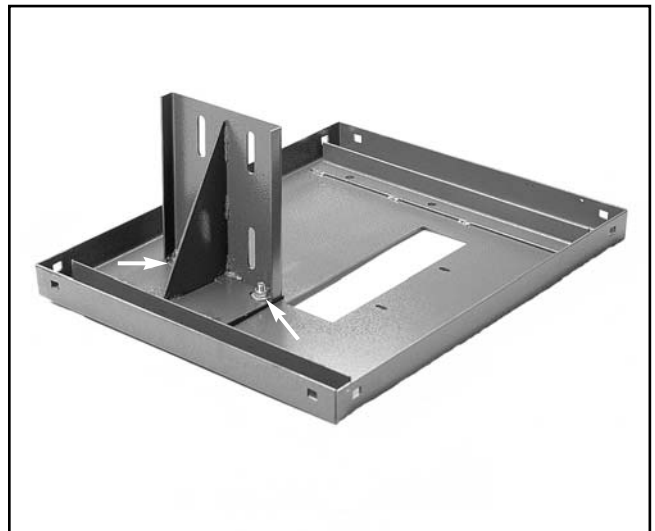

Figure 3. Attaching motor mount bracket.

2. Position the motor so the pulley is over the rectangular hole in the stand top as shown in **Figure 4**. Secure with four (4) $\frac{5}{16}$ "-18 x 1" carriage bolts, $\frac{5}{16}$ " washers, and $\frac{5}{16}$ "-18 nuts provided.

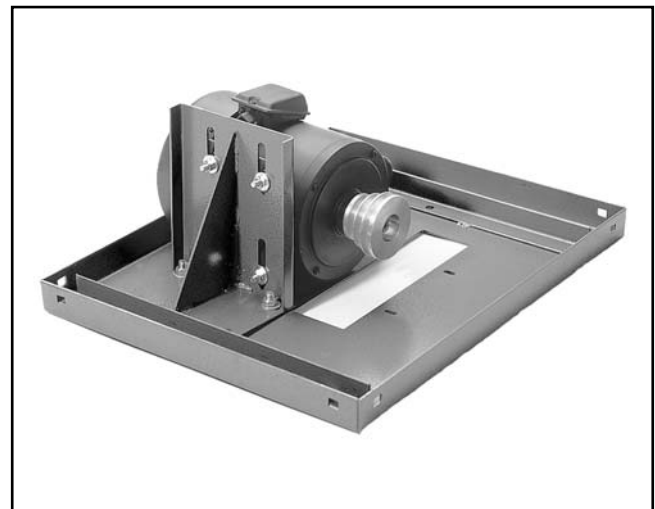

Figure 4. Motor attached to motor mount bracket.

G1073/G1073Z 16" Bandsaw

- Attach the four (4) legs to the inside of the stand top and the four horizontal braces to the inside of the legs as shown in **Figure 5**. Use the $\frac{5}{16}$ "-18 x $\frac{5}{8}$ " carriage bolts, $\frac{5}{16}$ "-18 nuts, and $\frac{5}{16}$ " washers provided. The two shorter braces are slightly wider than the longer braces. When attaching the braces to the legs, the longer braces rest inside the two flanges of the shorter braces. The square holes in the legs are angled to accommodate the angle of the legs.

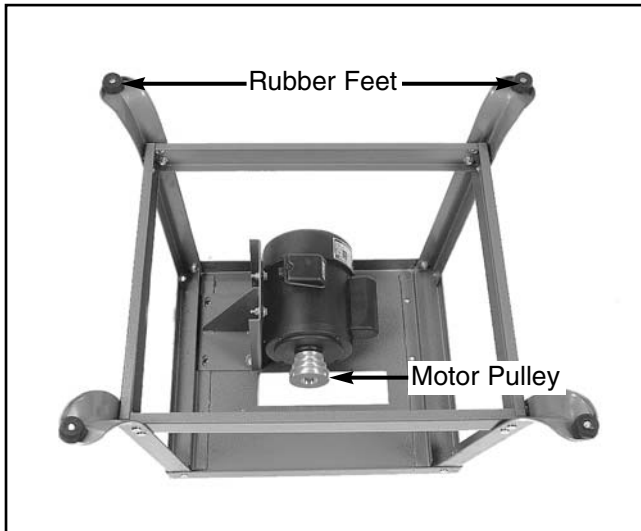

Figure 5. Legs and braces attached to top.

- Attach the four (4) rubber feet to the legs. Use four (4) $\frac{5}{16}$ "-18 x 1" hex head bolts, four (4) $\frac{5}{16}$ " flat washers and four (4) $\frac{5}{16}$ "-18 nuts provided. The bolts should go through the pad first and then through the feet. Tighten carefully so you do not deform the rubber feet.
- Slide the motor pulley onto the motor shaft and tighten the setscrew down. The small end of the pulley should be near the motor.
- Flip the stand/motor assembly rightside-up on the floor, but do not tighten the stand hardware at this time.



Bandsaw To Stand

	<p>WARNING</p> <p>The bandsaw (without stand and motor) weighs approximately 325 lbs. Use a lifting device or get help from people who can safely lift that much weight. Serious personal injury may occur if this warning is ignored.</p>
--	---

- Safely lift the bandsaw onto the stand. Ensure that the bandsaw step pulley is positioned over the hole in the stand.
- Attach the bandsaw to the stand with four (4) $\frac{3}{8}$ "-16 x 2" hex bolts, four (4) $\frac{3}{8}$ "-16 hex nuts, and eight (8) $\frac{3}{8}$ " washers provided. The bolts on the left side should go through the motor mount bracket. Hand tighten for now.
- Position the bandsaw on the stand so that the legs are evenly balanced and the stand is symmetrical in appearance, rather than lopsided. When the stand is positioned correctly on all four sides, tighten all the stand nuts to secure it in place.
- Working from the bottom up, tighten all stand bolts, motor mount bracket to the stand top (leave the motor bolts loose for now), and the bandsaw mounting bolts at the holes shown in **Figure 6**.

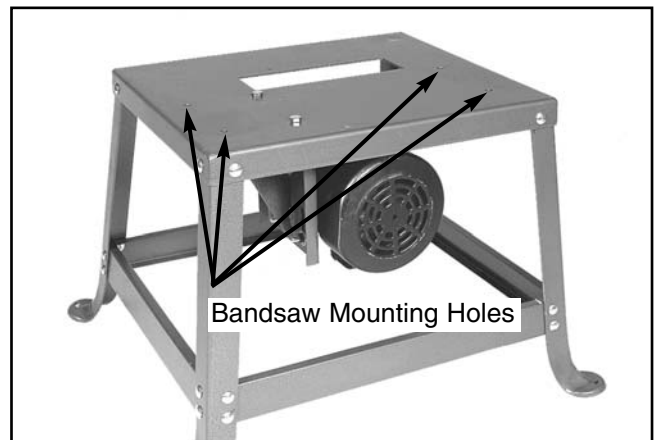

Figure 6.



Wiring The Motor

1. The Model G1073/G1073Z motor and ON/OFF switch each have a special connector for ease of wiring. Plug the connectors into each other as illustrated in **Figure 7**.
2. The motor is prewired for 220 volt operation. Install the appropriate 220V plug onto the power cord.
3. If 110 volt operation is desired and you are inexperienced with wiring, contact our Service Department for further information.
4. A wiring diagram is located on **Page 31** of this manual to further assist you with wiring details.

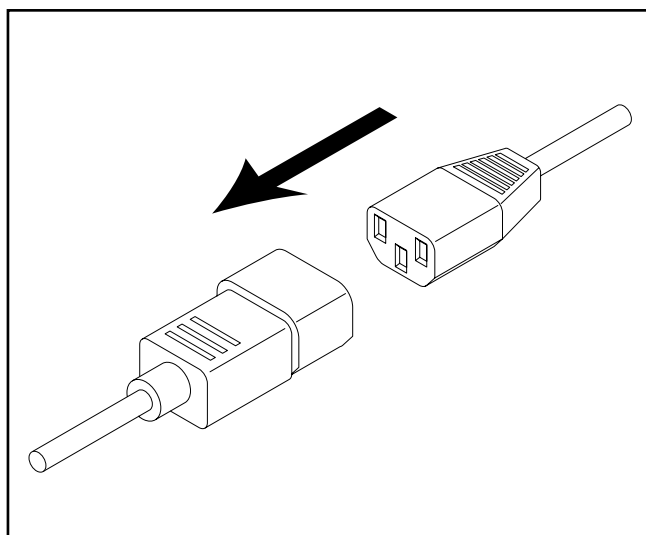

Figure 7. Plugging cords together.



V-Belt

To ensure optimum power transmission from the motor to the band wheels, align the pulleys, and tighten the V-belt.

To install the V-belt:

Slip the V-belt over the motor pulley and step pulley. Position the V-belt on the pulleys according to the speed you want (see **Figure 8** for speed chart). For general woodworking, we recommend the fastest blade speed.

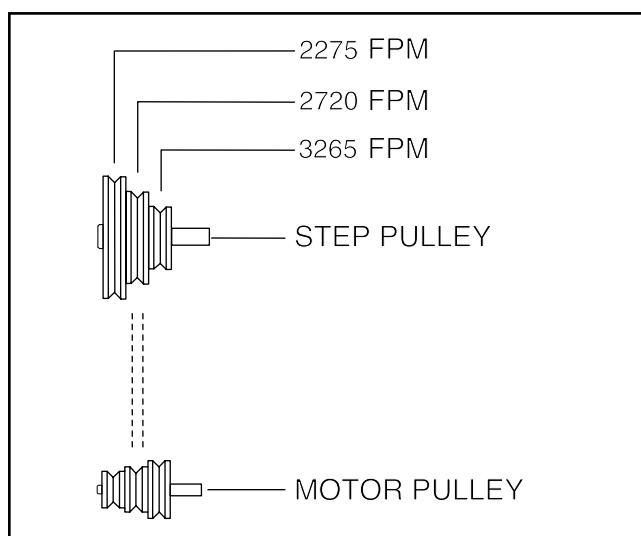

Figure 8. Pulley speed chart diagram.

Pulley alignment and belt tension should now be adjusted simultaneously.

1. Situate the motor so the V-grooves on the motor pulley approximately line up with the V-grooves on the three-step pulley. You may need to loosen the motor mount bracket bolts shown in **Figure 9A** to position the motor properly. Tighten the mount bracket to the stand before moving on to the next step. Leave the motor mount bolts loose.

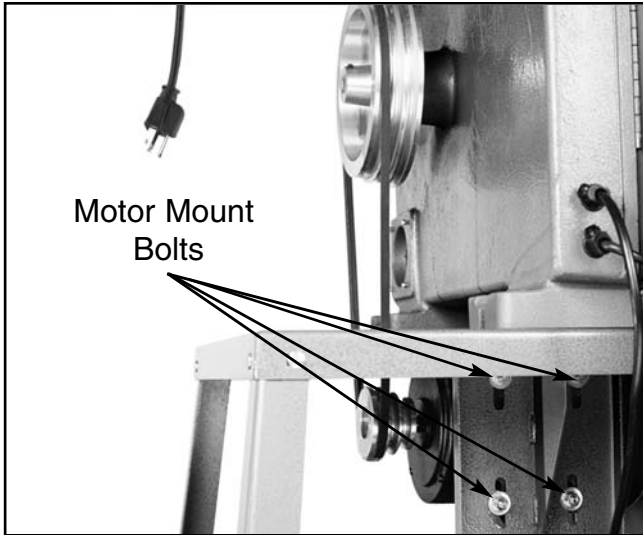

Figure 9A. Motor mount bolt locations.

If the pulleys will not align by moving the motor only, loosen the bandsaw mounting bolts and position the bandsaw so the step pulley aligns with the motor pulley. Leave the motor mount bolts loose.

2. Slide the motor up or down to achieve proper V-belt tension. You should be able to deflect the V-belt about $\frac{3}{4}$ " at its midpoint (see **Figure 9B**) using moderate finger pressure. Be careful not to change the lateral position of the motor and move the pulleys out of alignment. Tighten the motor mount bolts.

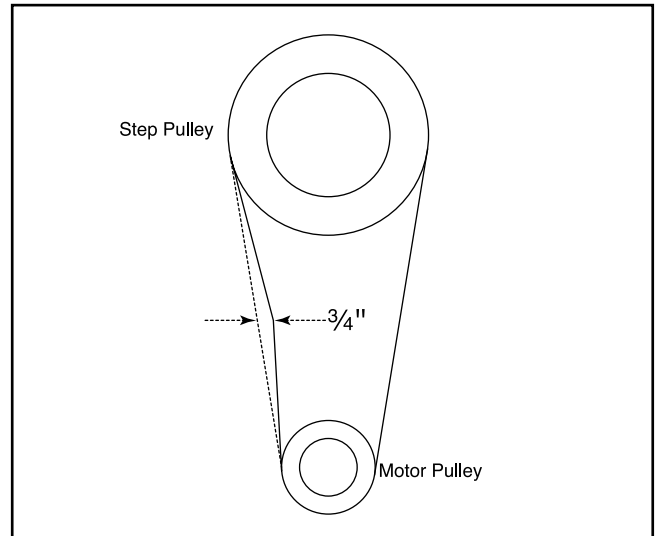

Figure 9B. Pulley deflection w/moderate pressure.

3. Check the pulley alignment with a plumb bob or straightedge. If you are using a plumb bob, the string must touch the outside flanges of each pulley evenly as shown in **Figure 10**, and the machine must be level.
4. Check V-belt tension. Repeat **steps 1-4** until both tension and pulley alignment are correct.

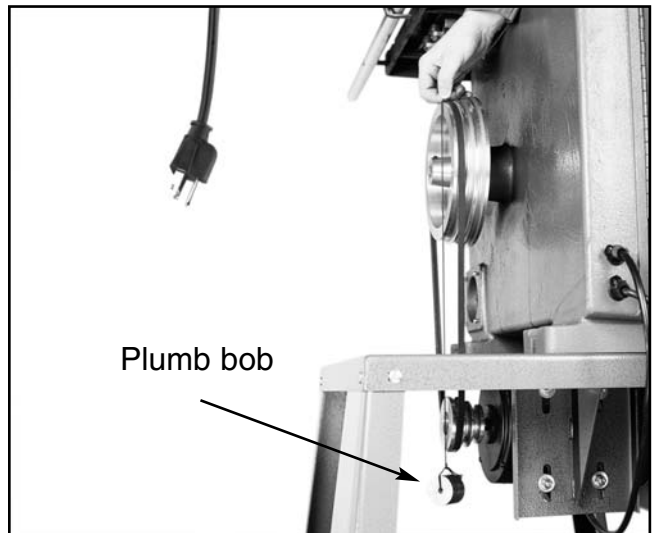

Figure 10. Aligning V-belt pulleys.



Working Table

The table secures to the trunnion support which mounts to the body casting. The trunnions are premounted to the table.

To mount the table and trunnion support:

1. Remove the three table bracket mounting bolts from the bandsaw body. **Figure 11** shows them removed.

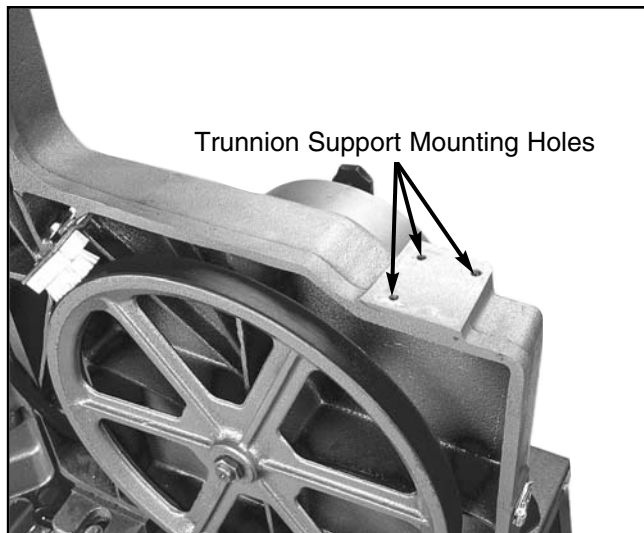

Figure 11. Trunnions removed from bandsaw.

2. Place the trunnion support on the body casting over the mounting holes, and secure it with the three bolts you just removed, making sure the support is placed so that the blade is centered between the guide-block brackets.
3. Release tension and remove blade. Refer to "Blade Changes" instructions if you need help. Position the table so that the miter slot will be to the right of the blade as you face the front of the bandsaw.

4. Orient the trunnion bolts under the table so they hang vertically.
5. Set the table trunnions onto the support. Make sure the trunnion bolts drop through the trunnion support slots.
6. Secure the table to the trunnion supports by tightening the two star knobs onto the trunnion bolts shown in **Figure 12**.

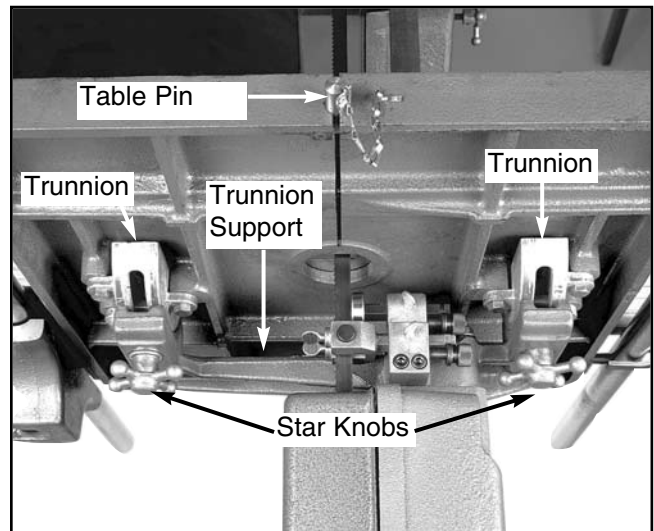

Figure 12. Under table controls.

7. Place the table insert in the table top and slide the table pin so it fits snugly in the hole on the right side of the table. **DO NOT** use excessive force.

NOTICE

The tapered table pin must be in position when operating the bandsaw.



Fence

The mounting holes in the rails are not centered on the length of the rails. This way, you can mount the rails so that maximum fence travel will be greater on one side or the other.

To mount the rails:

1. Secure the fence rails to the table with the four (4) 1/4"-20 x 1 1/4" cap screws and spacers provided (**Figure 13**).

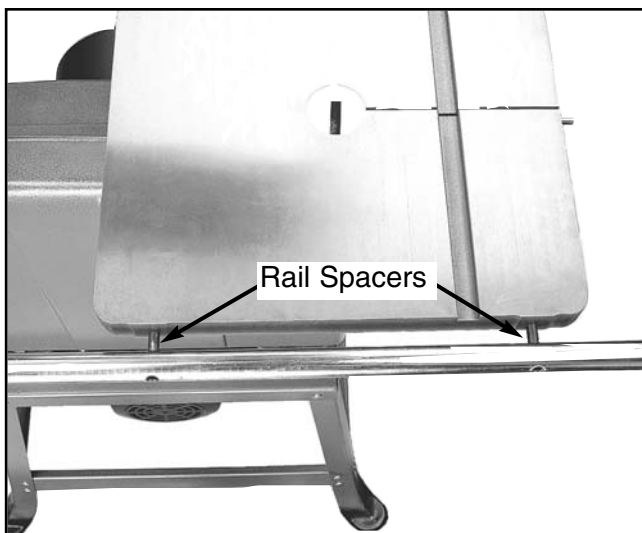

Figure 13. Fence rails properly secured to table.

2. Screw the fence locking handle into its position on the cam on the fence headstock. Move it to the loose (up) position.
3. Slide the fence onto the fence rails as shown in **Figure 14**.

NOTICE

When the fence is to the left of the blade, the fence must be positioned near the center of the table in order to open the lower wheel cover.

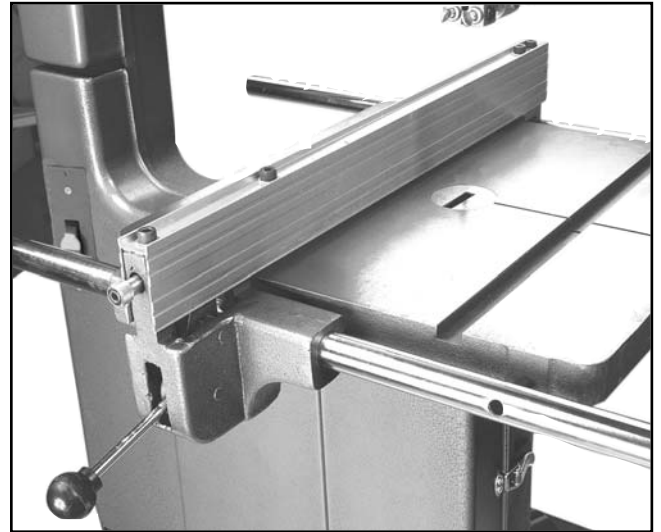

Figure 14. Fence mounted on rails.

There are two ways to remove the fence:

1. Remove the blade so the fence slides off the rails.
2. Dismount the rails by removing the cap screws.



Guard

Place the belt guard over the step pulley and secure it, as shown in **Figure 15**, to the stand using the $\frac{1}{4}$ "-20 x $\frac{1}{2}$ " hex head bolts, washers, and nuts provided. Fasten the guard to the band-saw by inserting the threaded rod through to the body casting and tightening the knob.

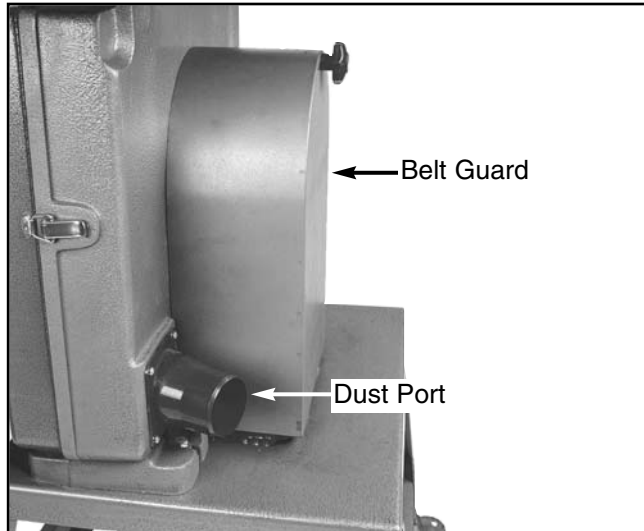

Figure 15. Belt guard and dust port mounted correctly on bandsaw.



Dust Port

The Model G1073 comes standard with a 2½" dust port for dust collection. It mounts to the lower rear casting body. This port can be connected directly to a 2½" Shop•Vac® hose or adapted to fit a standard 4" dust collector hose by using the Grizzly Model G3119 adapter between a 2½" and 4" hose.

To mount the dust port:

1. Remove the four dust port mounting screws from the bandsaw body and position the dust port as shown in **Figure 15**.
2. Replace the screws and secure the dust port to the bandsaw body.



SECTION 5: ADJUSTMENTS

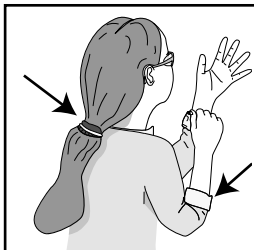

⚠ WARNING
Keep loose clothing rolled up and out of the way of machinery and keep hair pulled back.

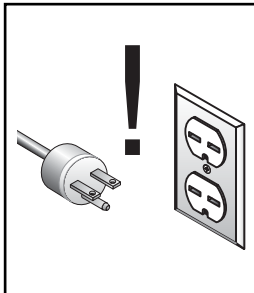

⚠ WARNING
Disconnect power to the machine when performing any maintenance or assembly. Failure to do this may result in serious personal injury.

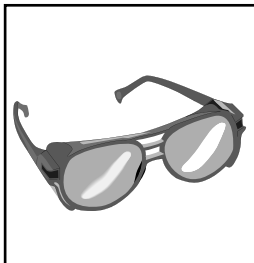

⚠ WARNING
Wear safety glasses during the entire adjustments process. Failure to comply may result in serious personal injury.

NOTICE

Read through the entire manual before starting the table saw.

Blade Tension

To adjust the tension:

1. Loosen the upper and lower guide blocks and lower the upper guide block down to the table. With moderate tension already on the blade, turn the bandsaw ON.
2. Release the tension one quarter of a turn at a time. Do this very slowly. When you see the bandsaw blade start to flutter, stop decreasing the tension.
3. Now, slowly increase the tension until the blade stops fluttering. Tighten the tension one quarter of a turn.

G1073/G1073Z 16" Bandsaw

If the tension seems correct, turn the bandsaw OFF and make the other adjustments, and test run. If the blade does not cut properly, the tension may be incorrect. Readjust the tension. New blades often stretch with use. However, it helps to always remove the tension from the blade when not in use.



Blade Tracking

There are two ways to track a bandsaw blade: **Center Tracking** and **Coplanar Tracking**. Center Tracking is the fastest and easiest, but not the most precise.

Center Tracking:

1. Disconnect the bandsaw from the power source and adjust the upper and lower guide assemblies away from the blade. Refer to **Page 18** for adjustment details.
2. Loosen the lock collar on the tracking control knob shown in **Figure 17**. Turn the tracking control knob clockwise/counterclockwise while turning the upper wheel by hand until the blade stays centered on the rubber tire.

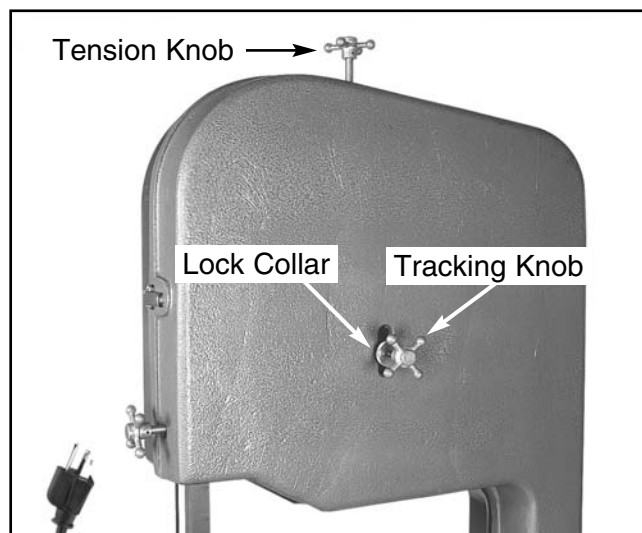

Figure 17. Tracking and tension controls.

3. Tighten the lock collar and check the tracking.

For the best performance from your saw, regularly maintain proper tracking of the blade.

For **Coplanar Tracking**, see the "Wheel Alignment" instructions.



Blade Guides

You must check the upper and lower support bearings and guide blocks each time before starting your bandsaw.

Always adjust the assemblies away from the blade before installing a new blade or making blade tracking adjustments. After blade tension and tracking are set correctly, readjust the upper and lower support bearings and guide block assemblies into position. See **Figure 18A** control locations.

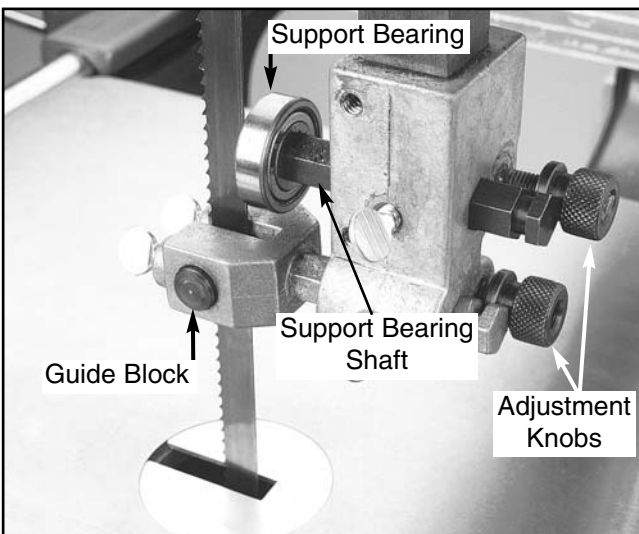
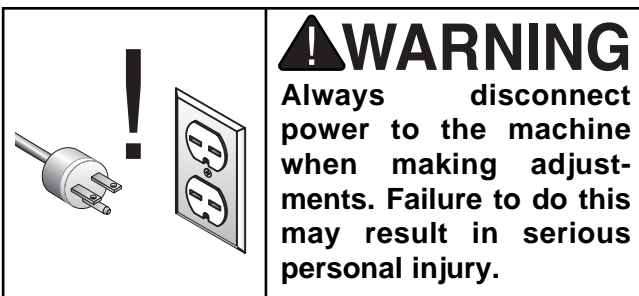

Figure 18A. Upper guide assembly.

The support bearings back-up the blade during the sawing operation. **To adjust the support bearings:**

1. Loosen guide blocks and loosen the setscrew that holds the guide block assembly to the guide post. Remove the guide block assembly.
2. Loosen the thumbscrew that secures the support bearing shaft and unscrew the adjustment knob that controls the support bearing shaft. See **Figures 18A/B** for locations.
3. Remove the support bearing shaft from the guide block assembly. Rotate the the shaft so the blade will ride off-center against the support bearing as shown in **Figure 18B**. Install the shaft, tighten the mounting setscrew and replace the adjustment cap.
4. Turn the adjustment cap so that the upper and lower support bearings are approximately .016" (thickness of a dollar bill x 4) behind the blade. Tighten the thumbscrews.
5. To adjust the lower support bearing, remove the lower guide block assembly by taking out the two setscrews that mount it to the bandsaw body. Make the same adjustments described in steps 2-4 and mount the guide block assembly back to the bandsaw body.

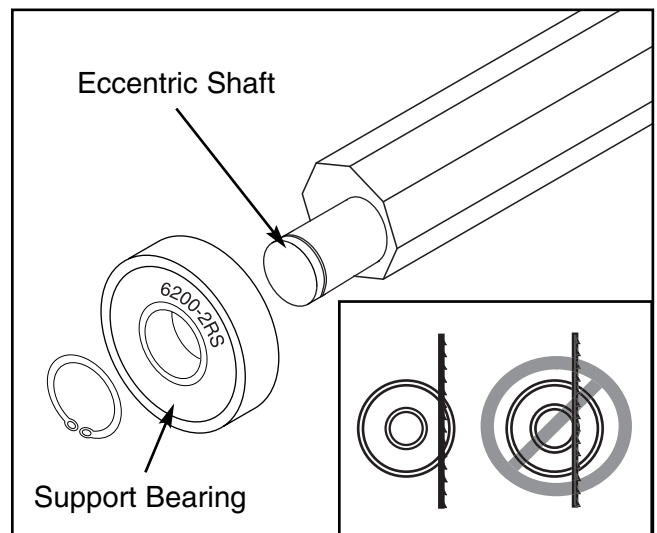

Figure 18B. Eccentric blade support.

Guide Blocks

The guide blocks ensure that the blade is not pushed too far laterally. Perform **steps 1-4** for both upper and lower guide blocks. **To adjust the guide blocks:**

1. Loosen the thumbscrew securing the guide block shaft shown in **Figure 19**.
2. Turn the adjustment nut so that the front of the guide blocks are just behind the gullet line (the hollow points) of the blade. Tighten the thumbscrew.
3. Loosen the guide block thumbscrews and adjust the gap between the blocks and the blade to .004" (about the same thickness as a dollar bill). See **Figure 19**.
4. Tighten the thumbscrews.

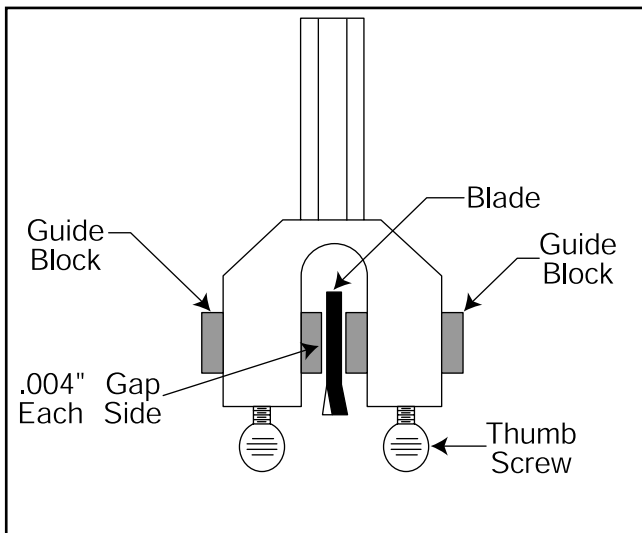

Figure 19. Guide block location of controls.



Table Stop

The positive stop under the table allows you to repeatedly square up the table after adjusting the table tilt.

To adjust this positive stop so the table will return perpendicular (90°) to the blade after angle cutting:

G1073/G1073Z 16" Bandsaw



1. Loosen the star knobs under the table and the checknut securing the stop.
2. Raise the upper blade guide assembly and place a 6" machinist's square on the table against the blade as shown in **Figure 20**. Notice how far out of square your table is and approximate this distance by adjusting the positive stop up or down. Turning the positive stop counterclockwise will raise it and turning clockwise will lower it. Adjust the positive stop so the table will stop at a 90° angle (square) to the blade.
3. Lock the positive stop by tightening the checknut. Do not let the stop turn while tightening the checknut. Tighten the star knobs. Set the angle pointer to zero on the gauge.

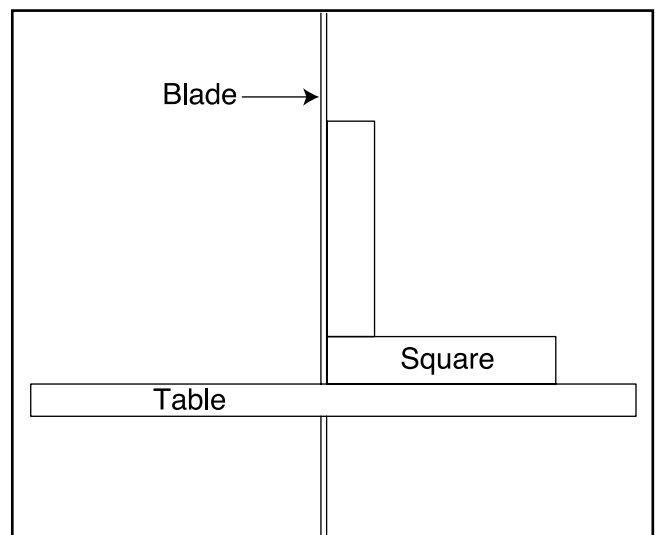

Figure 20. Squaring table to blade.

4. A stop cap covers the positive stop. A pre-determined thickness in the end of this cap will automatically allow the table to tilt toward the column of the saw 10° when this cap is removed as shown **Figure 21**.

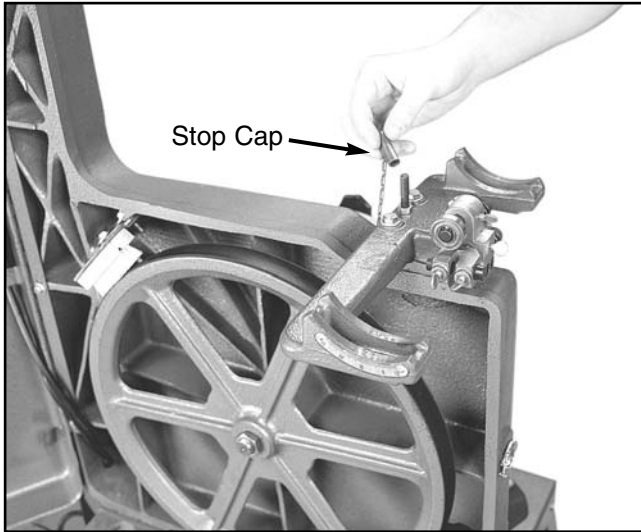

Figure 21.



Table Parallelism

To position the blade line parallel to the miter slot:

1. Ensure that the bandsaw is not connected to a power source, and install the widest blade available.
2. Loosen the 6 bolts securing the trunnions to the table OR loosen the 3 trunnion support mounting bolts securing the trunnion support to the bandsaw. Leave the star knobs tight. **Figure 22** shows the location for these controls.
3. Lay a straightedge against the left side of the blade so that the straightedge touches the front and back side of the blade.
4. With a fine ruler, measure the distance from the straightedge to the edge of the miter slot. This measurement should be taken at both the front and back of the table. If both measurements are the same, proceed to **step 6**.
5. Rotate the table in the desired direction until the two measurements at the front and back are even.

6. Secure the table by tightening the bolts. Make sure the table did not shift. If you continue to have problems with this, see the "Blade Lead" instructions.

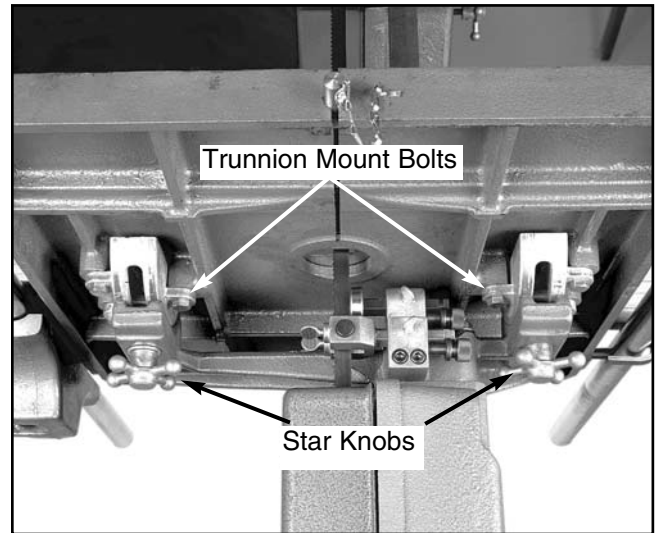

Figure 22.



Table Tilt

To tilt the table:

1. Loosen the two star knobs below the trunnions shown in **Figure 22**.
2. Tilt the table to the desired angle. Refer to the angle gauge.
3. Tighten the star knobs.

NOTICE

If setting table tilt to the left, first tilt the table to the right, remove the cap on the positive stop, and then tilt the table to the left.



Blade Changes

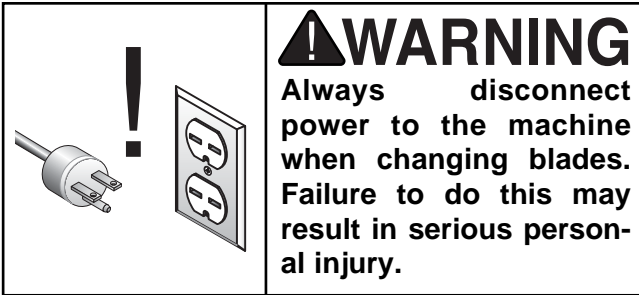

To remove the blade:

1. Release tension on the blade by turning the tension control knob counterclockwise.
2. Remove the table insert and table pin.
3. Adjust upper and lower guide blocks away from the blade.
4. Put on leather gloves to protect your hands from the sharp teeth of the blade.
5. Open the upper and lower wheel covers and slide the blade off both wheels. Use caution—the blades are sharp!
6. Rotate the blade 90° so it will slide through the slot in the table as shown in **Figure 23**.

! CAUTION

Wear gloves and safety goggles when handling blades. Coiled blades spring open as they are uncoiled and could cause deep cuts or lacerations.

When removing or installing wide blades, it may be convenient to completely remove the upper and lower guide blocks. Be sure to replace them before cutting. **To replace the blade:**

1. Slide the blade through the table slot, ensuring that the teeth are pointing down toward the table.

If the teeth will not point downward in any orientation, the blade is inside out. Put on heavy gloves, remove the blade, and twist it inside out.

G1073/G1073Z 16" Bandsaw

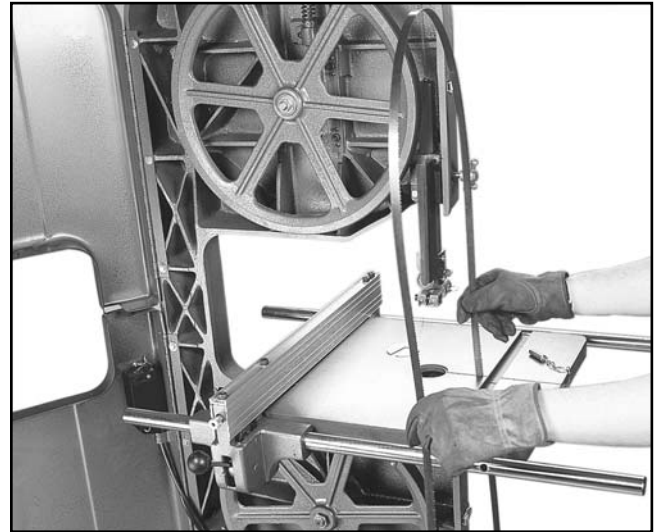

Figure 23. Changing blade with leather gloves.

2. Slip the blade through the upper and lower guides, and mount it over the upper and lower wheels.
3. Apply tension, then check and adjust tracking.
4. Adjust the upper and lower guide blocks and support bearings.
5. Close the wheel covers and latch them.
6. Replace the table insert and table pin, being sure not to use excessive force.



Guide Post

The guide post is adjustable so the guide blocks will stay aligned with the blade when the guide post is raised or lowered.

To check guide post alignment:

1. Adjust blade tension and tracking.
2. Loosen the guide post securing knob and slide the guide post all the way up. Lock it in position by tightening the securing knob shown in **Figure 24A**.

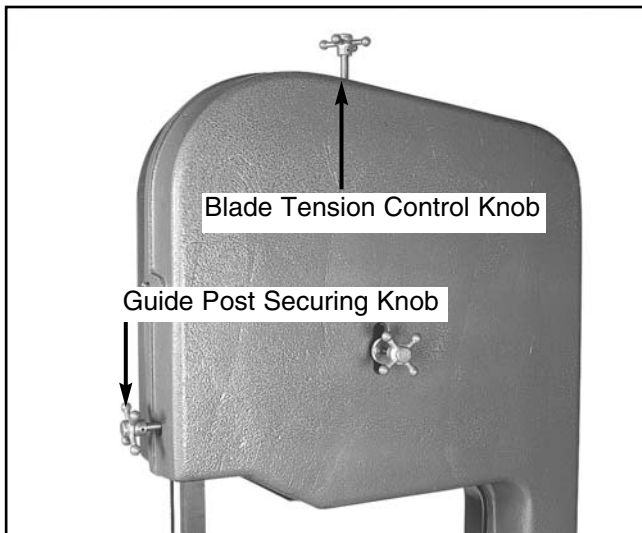

Figure 24A. Tension and guide post controls.

3. Adjust the upper guide blocks away from the blade.
4. Note where the blade is in the guide block holder. It should be roughly centered. If it is not centered, shift the eccentric at the bottom of the guide post (shown in **Figure 24B**). This is done by loosening the setscrew on the guide block assembly and pulling it off the guide post. The setscrew on the back of the guide post will allow you to loosen the eccentric so you can center the assembly to the blade.
5. Slide the guide post all the way down and lock it in position. If the blade appears to be closer to one side of the guide block holder than when the guide post was all the way up, adjust the guide post bracket.

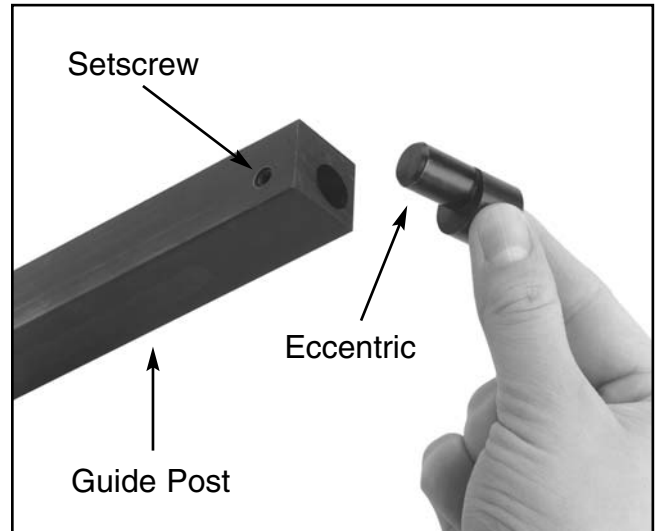

Figure 24B. Eccentric at bottom of guide post.

To adjust the guide post bracket:

1. Loosen the two bracket bolts (shown in **Figure 25A**) securing the guide post bracket to the body casting.
2. Shift the guide post bracket in the desired direction to center the blade between the blade guide bracket.
3. Tighten the two hex bolts and check your results by sliding the guide post up and down. If the post is correct, the blade will remain centered in the blade guide brackets.
4. Repeat **Steps 1-3** as needed.

If the guide post bracket will not adjust enough, shift the blade slightly.

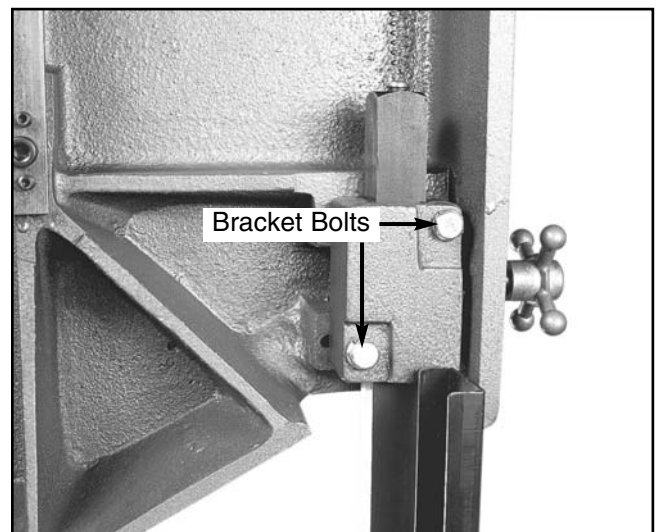

Figure 25A. Location of bracket bolts.

G1073/G1073Z 16" Bandsaw

To shift the blade:

1. Loosen the tension on the blade.
2. Remove the spacers (**See Figure 25B**) behind the upper wheel in the desired direction. Move the upper wheel left or right as needed, and replace the spacers on the opposite side from where they were removed.
3. Readjust the tension. This will secure the wheel.
4. Repeat guide post bracket adjustments.

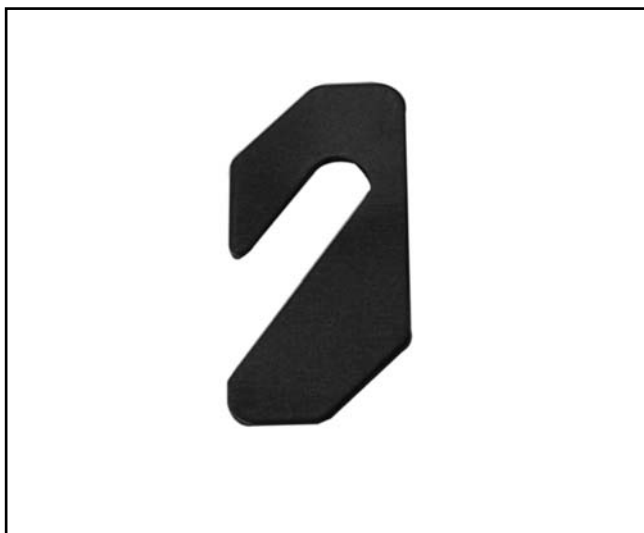

Figure 25B. Upper wheel spacer.



Fence Adjustment

Fence locking is controlled by the lever on the front of the fence. When the lever is pushed down, it locks the front and rear of the fence to the guide rails. The end of the fence nearest to the operator should lock before the rear.

Use a tape measure or ruler to measure the distance from the fence to the blade. **To adjust the front clamping pressure:**

1. Lift the lever to the “loose” position.
2. Loosen the checknut below the clamp shoe shown in **Figure 26**.

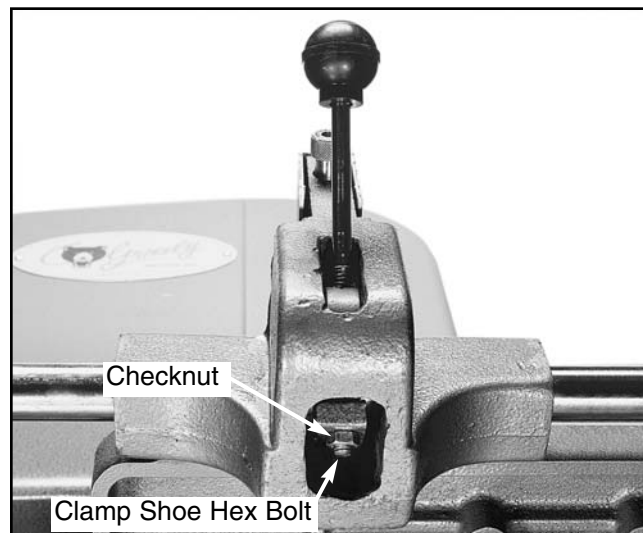

Figure 26. Location of checknut.

3. Using a wrench, turn the clamp shoe hex bolt to adjust the clamping pressure.
4. Push the locking lever down to test the clamping pressure. The fence should be tightly clamped to the front rail when the lever is pushed all the way down.
5. Repeat **steps 3-4** until the fence clamps correctly. Tighten the checknut. Be careful not to turn the clamp shoe hex bolt or the clamping pressure will be altered.

To adjust the rear clamping pressure:

1. Back out the rear clamp adjusting screw several turns and put the locking lever in the locked position as shown in **Figure 27**.
2. Turn the rear clamp adjusting screw until the rear clamp just touches the top of the rear guide rail.
3. Continue to turn the rear clamp adjusting screw another $\frac{3}{4}$ turn.
4. Test the clamping pressure by loosening and tightening the locking lever.

- Slide the fence along the rails. It should slide easily.
- Lock the handle again and check fence position. The front of the fence should lock just before the rear of the fence as the handle is pushed down through its full motion.

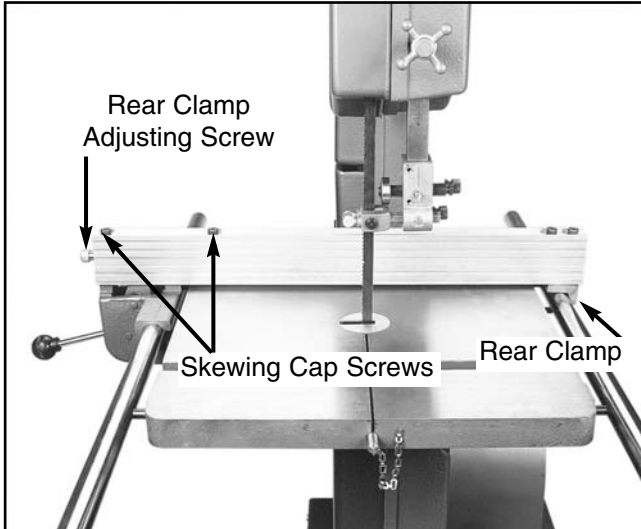

Figure 27. Fence controls.



Blade Lead

Most bandsaw blades will not appear to cut straight when using the fence or miter gauge. This is called "lead." (See **Figure 28**.) Lead occurs (1) if the blade tension is incorrect, (2) if the teeth are dull on one side, or (3) if the teeth are set heavier on one side of the blade than the other.

If you notice that your blade is not cutting straight (i.e. leading) while using the fence or miter gauge:

- Check that the miter slot is parallel to the blade line.
- Check that you have proper blade tension. If the blade tension is correct and it is not convenient to replace the blade, compensate for lead by skewing the fence or adjusting the table.

To skew your fence:

- Make a piece of scrap wood that is approximately $\frac{3}{4}$ " thick x 3" wide x 17" long. On a wide face of the board, draw a straight line parallel to the long edge.
- Slide the fence out of the way and cut free-hand along the line. Stop at the halfway point. Turn the bandsaw off and *wait for the blade to stop*.
- Clamp the board to the bandsaw table **without moving it**. Now slide the fence over to the board so it barely touches one end of the board.
- Loosen the two skewing cap screws on top of the fence. **Figure 27**.
- Skew the fence left or right so it is parallel to the edge of the scrap piece. You may need to readjust the fence locking mechanisms to gain maximum adjustment.
- While maintaining the skew, tighten the cap screws.

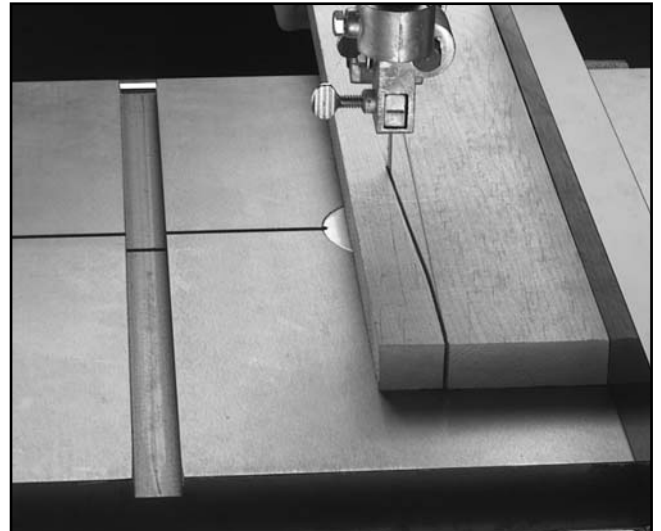

Figure 28. Blade leading away from line of cut.

To compensate for lead if making straight crosscuts using the miter gauge, you will need to shift the table. To do this:

1. On a scrap piece of wood, mark a line that is perpendicular to the front edge. Starting where the line begins, cut the board by pushing it through the blade with the miter gauge.
2. Loosen the table mounting bolts according to the instructions about "Table Parallelism" on page 20. Shift the table to compensate for the blade lead.
3. Repeat **steps 1 and 2** until the blade cuts straight when wood is pushed through with the miter gauge.

NOTICE

If the table is shifted, the fence will be affected since it is attached.

NOTICE

Lead adjustments will change when new blades are mounted in the saw.



Wheel Alignment

Wheel alignment is one of the easiest ways to ensure you get optimal performance from your bandsaw. When wheels are aligned, or coplanar, the bandsaw is more likely to cut straight without wandering; and vibration, heat, and blade wear are considerably decreased because the blade is automatically balanced on the wheel. This is known as "**Coplanar Tracking.**"

To verify if the the upper and lower wheels are coplanar:

1. With the blade on and properly tensioned, hold a straightedge close to the center of both wheels. Make sure it fully extends across them as in **Figure 29.**

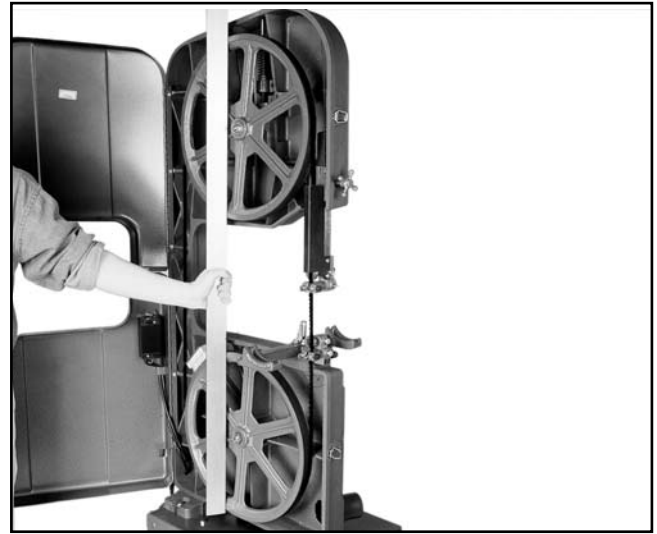

Figure 29. Holding a straightedge across both wheels.

2. A perfectly coplanar set of wheels will allow the straightedge to touch the top and bottom of the outside rims on each wheel. If this is the case with your wheels, then they are coplanar.
3. If your wheels are not coplanar, check them for adjustment by placing the straightedge on the upper wheel first – ensuring that it touches both the top and bottom rim – and adjust the tracking knob to see how the straightedge lines up with the lower wheel.

If the straightedge only touches the top rim of the lower wheel, then the upper wheel needs to be shimmed.

If the straightedge only touches the bottom rim of the lower wheel, then the lower wheel needs to be shimmed.

Shimming a wheel.

1. Adjust the tracking knob so the top wheel is parallel with the bottom wheel. With the straightedge touching both points of the wheel that does not need to be adjusted, measure the distance away from the incorrect wheel with a fine ruler. See **Figure 30.** The distance you measured with the ruler is the distance the wheel must be corrected.

- Remove the blade from the saw, then the securing nut and washers from the wheel that needs to be shimmed. Now remove the wheel. Use the washers that were behind the securing nut for shims. Measure how many you will need to equal the space of your gap and place them on the mounting shaft.

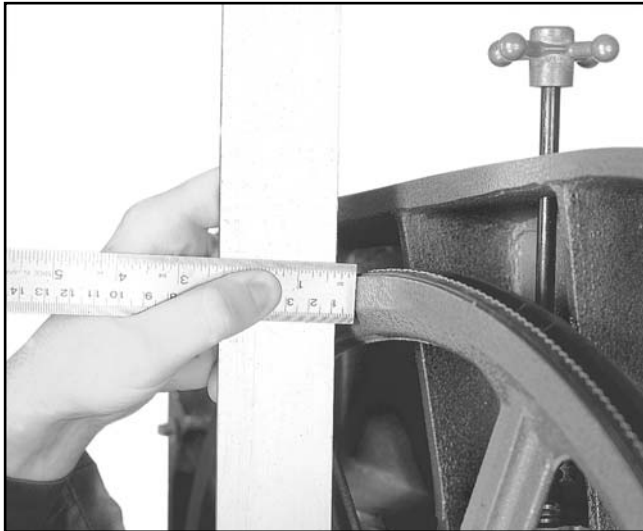

Figure 30. Measuring wheel difference.

- Replace wheel, any remaining washers and the securing nut. It is important to tighten the blade as it will be used during operation before you check the wheels for being coplanar. In other words, it is possible that the wheels may be coplanar with the blade loose, then be pulled out of alignment when it is tightened.
- The first time you get the wheels coplanar it is a good idea to place a mark on each wheel where you held the straightedge. This assures repeated accuracy every time you adjust your wheels.

NOTICE

When wheels are properly coplanar, the blade may not be centered on the crown of the wheel, but it will be balanced.

Adjusting Parallelism

To adjust a parallelism problem (i.e., if the middle of the wheels are coplanar, but the sides are not, **Figure 31.**) follow these steps.

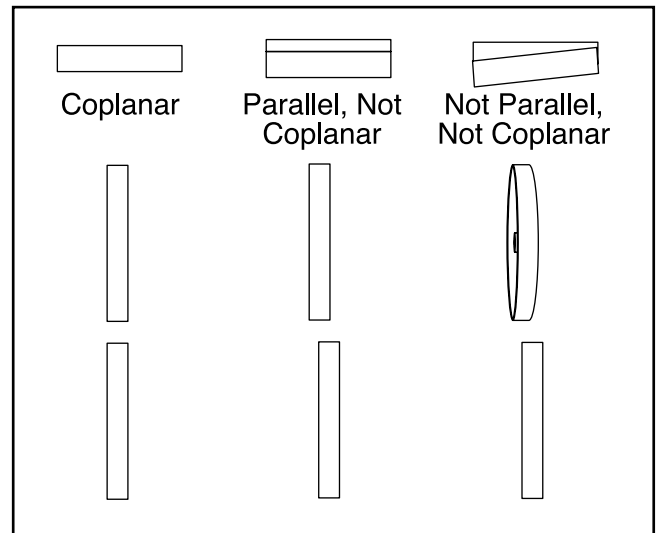

Figure 31. Coplanar diagram.

- Loosen the four cap screws securing the two sliding gibs to the body behind the upper wheel, as shown in **Figure 32.**

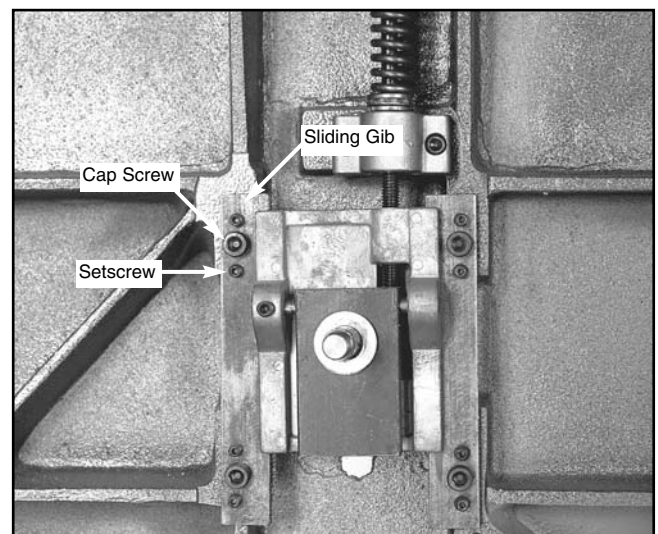
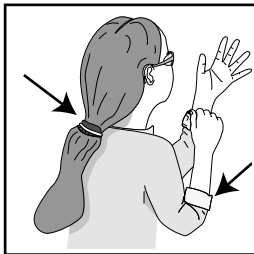

Figure 32. Horizontal controls for upper wheel.

- Adjust the setscrews in or out very slightly (over-adjustment will cause the tension rod to bind). Use your straightedge from the previous section to make the upper wheel parallel with the lower wheel.
- Tighten the four cap screws and check wheel alignment.



SECTION 6: OPERATIONS



⚠ WARNING
Keep loose clothing rolled up and out of the way of machinery and keep hair pulled back.

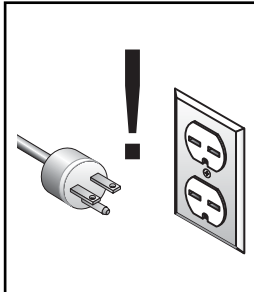

⚠ WARNING
Disconnect power to the machine when performing any maintenance or assembly. Failure to do this may result in serious personal injury.



⚠ WARNING
Wear safety glasses during the entire operation process. Failure to comply may result in serious personal injury.

Test Run

Once the assembly is complete and the adjustments are done to your satisfaction, you are ready to test the machine.

Turn on the power supply at the main panel. Pull the paddle switch up to start the bandsaw. Make sure that your hand is poised over the switch in case there is a problem. The bandsaw should run smoothly with little or no vibration or rubbing noises. Strange or unnatural noises should be investigated and corrected before operating the machine further.

If you cannot easily locate the source of an unusual noise or vibration, feel free to contact our service department for help.

Blade Selections

The Model G1073/G1073Z 16" Bandsaw accepts 113" blades. The tension adjustment will accommodate blades up to a maximum length of 114" and down to a minimum length of 112" (approx.).

A bandsaw blade is a delicate piece of steel that is subjected to tremendous strain. Take care of your blades and they will last a long time. Be sure you use quality blades of the proper width for the various types of cutting operations.

Always use the widest blade possible for the workpiece you are cutting. Use narrow blades only for sawing small, abrupt curves and for fine, delicate work. Grizzly supplies bandsaw blades in various widths for this saw. Please refer to our current catalog for prices and ordering information.

Many conditions may cause a bandsaw blade to break. Blade breakage is, in some cases, unavoidable because of the peculiar stresses to which bandsaw blades are subjected. Blade breakage is also due to avoidable causes. Avoidable breakage is most often the result of poor care or judgement on the part of the operator when mounting or adjusting the blade or support guides. **The most common causes of blade breakage are:**

- Forcing or twisting a wide blade around a curve of short radius.
- Feeding material too fast.
- A dull or defective blade.
- Excessive tension.
- Improperly adjusted blade guides.
- Continuously running the bandsaw when not in use.



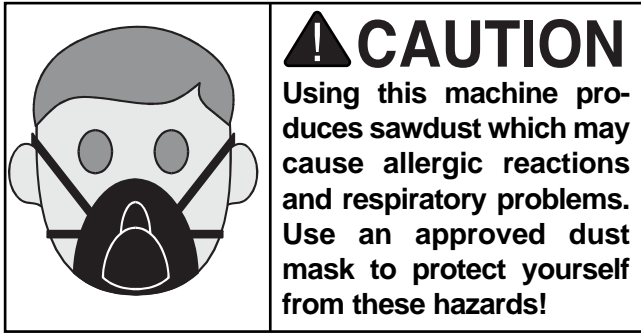

Resawing

Resawing is the process of cutting a board into two or more thinner boards. The maximum board width that can be resawn is limited by the maximum cutting height of the bandsaw. Maximum cutting height for this bandsaw is 7³/₄".

Use common sense when resawing. Attempting to resaw too wide or too dense of a board may put excessive strain on the blade and be dangerous.

Blade selection is an important consideration when resawing. Generally, the wider the blade, the better. In most applications, a hook or skip tooth style will be sufficient. Also, since most resawn lumber will be planed smooth, you can choose blades with fewer teeth per inch (from 3 to 6). While blades with fewer teeth per inch produce rougher cuts, these types of blades offer larger gullet capacities for clearing sawdust, less heat buildup, and yield more horsepower per tooth.

To resaw lumber:

1. The bandsaw must be adjusted correctly. See **Blade Adjustment** section.
2. The table must be square to the blade. See **Table Adjustment** section.
3. Use the widest blade available. The blade must also be in good condition.
4. Use a fence to guide work.
5. Draw a reference line on the edge of the board.
6. Support ends of the board if necessary.
7. Feed work slowly and evenly.

Cutting Curves

When cutting curves, simultaneously feed and turn the stock carefully so that the blade follows the layout line without being twisted. If a curve is so abrupt that it is necessary to repeatedly back up and cut a new kerf, use either a narrower blade or a blade with more set. A blade with more set can cut relatively tighter radii, though the cut is usually rougher than cuts produced by a blade with medium set.

Always make short cuts first, then proceed to the longer cuts. Relief cuts will also reduce the chance that the blade will be pinched or twisted. Relief cuts are made through the waste portion of the workpiece and are stopped at the layout line. As you cut along the layout line, waste wood is released from the workpiece, alleviating any pressure on the back of the blade. Relief cuts also make backing the workpiece out easier, if needed.

The table below lists blade widths and corresponding minimum radii each blade will cut:

Width	Radius
1/8"	3/16"
3/16"	5/16"
1/4"	5/8"
3/8"	1 1/2"
1/2"	2 1/2"
5/8"	4"
3/4"	5 1/2"



SECTION 7: MAINTENANCE

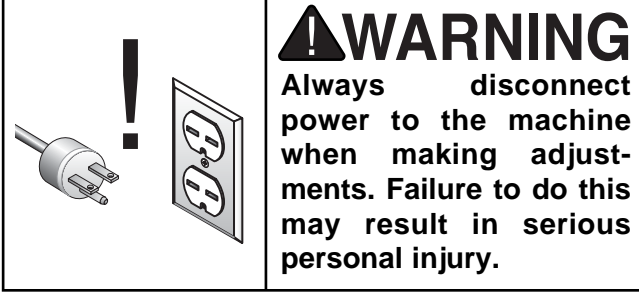

V-Belts

To ensure optimum power transmission from the motor to the blade, the V-belt must be in good condition and operate under proper tension. The belts should be checked for cracks, fraying and wear. Belt tension should be checked at least every 3 months; more often if the bandsaw is used daily.

The V-belt is accessed via the bottom cover:

1. Squeeze the center of the V-belt.
2. Note the amount of deflection. Deflection should be approximately $\frac{3}{4}$ ". See "V-Belt Adjustment" instructions.



Miscellaneous

Always be aware of the condition of your bandsaw. Routinely check the condition of the following items and repair or replace as necessary:

- Loose mounting bolts
- Worn switch
- Worn or damaged blade
- Worn or damaged support bearings or guide bearings



G1073/G1073Z 16" Bandsaw

Table

The table and other non-painted surfaces on the Model G1073/G1073Z should be protected against rust and pitting. Wiping the saw clean after every use ensures that wood dust is not allowed to trap moisture against bare metal surfaces.

The table can be kept rust-free with regular applications of products like SLIPIT® or Boeshield® T-9. For long term storage you may want to consider products like Kleen Bore's Rust Guardit™. See the current Grizzly catalog for more on these products.



Lubrication

Shielded and pre-lubricated ball bearings require no lubrication for the life of the bearings. All bearings are standard sizes, and replacements can be purchased from our parts department or bearing supply store.

As for other items on this machine, such as adjustment controls, an occasional "shot" of light oil is just about all that is necessary. Before applying, however, wipe off any sawdust with a clean cloth, towel or dry paint brush, and spray on the lubricant. Ensure that oil does not get on the pulleys or V-belt because it could cause belt deterioration and slipping.



SECTION 8: CLOSURE

The following pages contain general machine data, parts diagrams/lists, troubleshooting guide and Warranty/Return information for your Model G1073/G1073Z 16" Bandsaw.

If you need parts or help in assembling your machine, or if you need operational information, we encourage you to call our Service Department. Our trained service technicians will be glad to help you.

If you have comments dealing specifically with this manual, please write to our Bellingham, Washington location using the address in the **General Information** section. The specifications, drawings, and photographs illustrated in this manual represent the Model G1073/G1073Z as supplied when the manual was prepared. However, due to Grizzly's policy of continuous improvement, changes may be made at any time with no obligation on the part of Grizzly.

We have included some important safety measures that are essential to this machine's operation. While most safety measures are generally universal, Grizzly reminds you that each workshop is different and safety rules should be considered as *they apply to your specific situation*.

WARNING

Operating this equipment has the potential for flying debris to cause eye injury. Always wear safety glasses or goggles when operating equipment. Everyday glasses or reading glasses only have impact resistant lenses, they are not safety glasses. Be certain the safety glasses you wear meet the appropriate standards of the American National Standards Institute (ANSI).

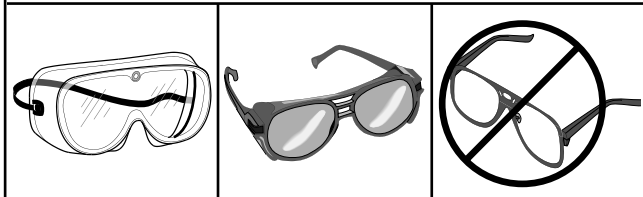

We recommend you keep a copy of our current catalog for complete information regarding Grizzly's warranty and return policy. If you need additional technical information relating to your machine, or if you need general assistance or replacement parts, please contact the Service Department listed in the **General Information** section.

Additional information sources are necessary to realize the full potential of your machine. Trade journals, woodworking magazines, and your local library are good places to start.

WARNING

Like all power tools, there is danger associated with the Model G1073/G1073Z 16" Bandsaw. Use the tool with respect and caution to lessen the possibility of mechanical damage or operator injury. If normal safety precautions are overlooked or ignored, serious personal injury may occur.

WARNING

The Model G1073/G1073Z was specifically designed for wood cutting operations. **DO NOT MODIFY AND/OR USE THIS BANDSAW FOR ANY OTHER PURPOSE.** Modifications or improper use of this tool will void the warranty. If you are confused about any aspect of this machine, **DO NOT** use it until all your questions are answered. Serious personal injury may occur.

WIRE DIAGRAM

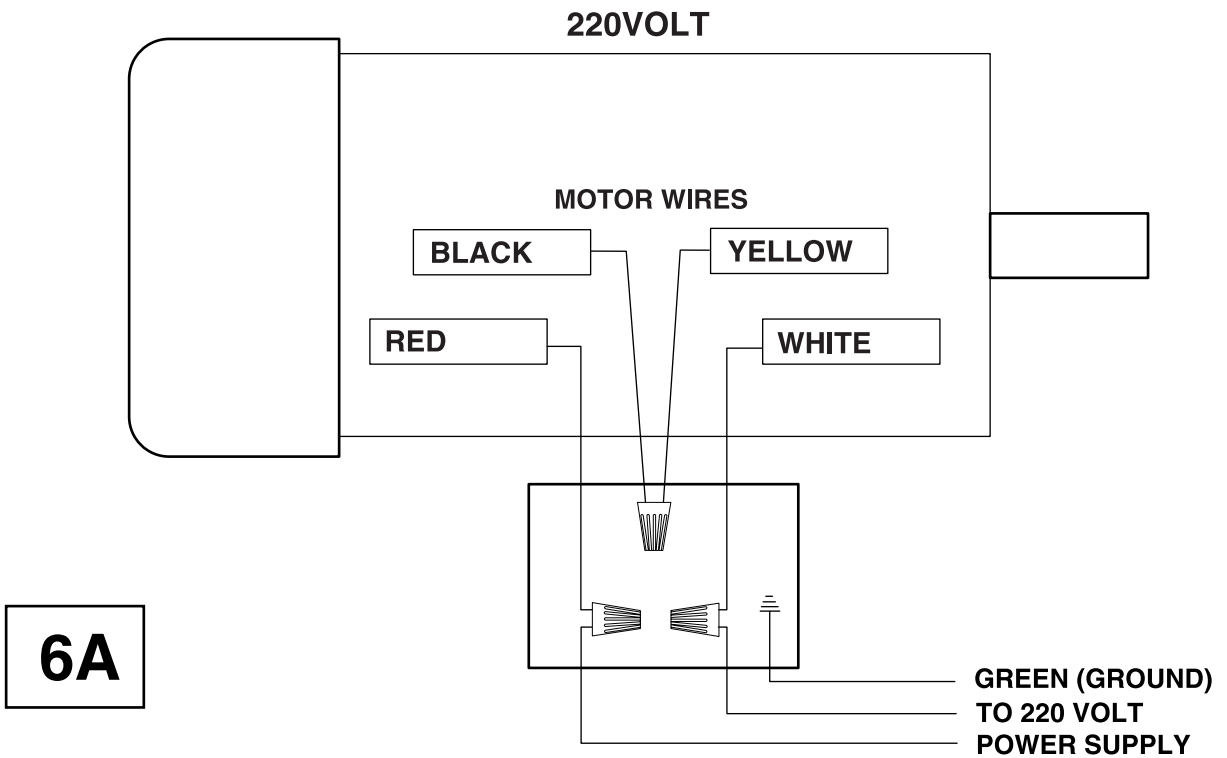
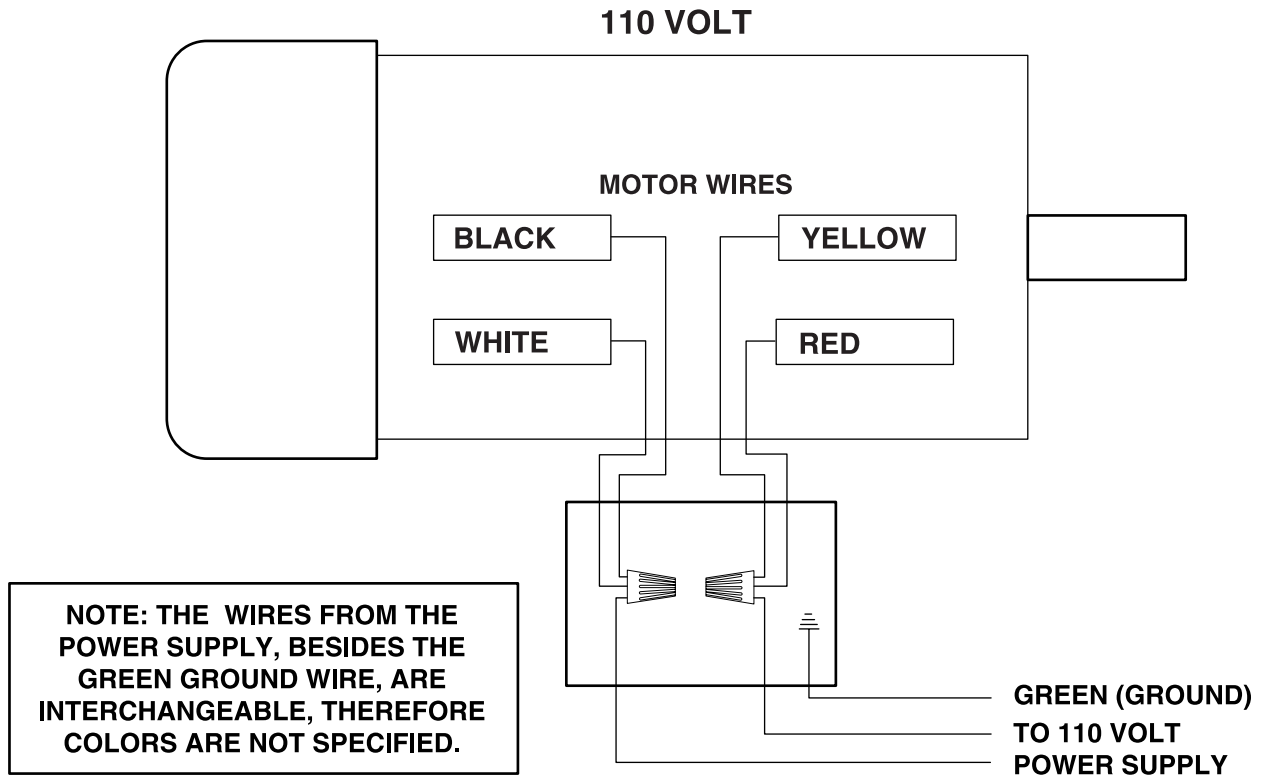



MACHINE DATA SHEET

Customer Service #: (570) 546-9663 • To Order Call: (800) 523-4777 • Fax #: (800) 438-5901

MODEL G1073/G1073Z 16" BANDSAW

Design Type:2 Wheel Floor Model, 3 Speed
(G1073 Open Stand, G1073Z Cabinet Stand)

Overall Dimensions:

Table17" x 17" x 1½" Thick
 Stand.....16" H x 24" W x 21" L
 Overall Height72"
 Height from Floor to Table40"
 Width of Unit35"
 Depth of Unit20"
 Shipping Weight.....Approx. 456 lbs.
 Crate Size16" H x 26" W x 60" L

Cutting Capacity:

Left of Blade16 ¼"
 Height.....7 ¾"

Construction:

TablePrecision Ground Cast Iron
 WheelsFully Balanced Cast Iron with Rubber Tire
 Rip FenceDouble Lock, Adjustable, Extruded Aluminum
 Wheel CoversPreformed Steel
 Guides.....Steel Blocks with Ball Bearing Guides

Motor:

Type.....TEFC Capacitor Start Induction
 Horsepower2 H.P.
 Phase/CycleSingle-Phase/60 Hz
 Voltage110V/220V-rewired 220V
 Amps24A @ 110V/12A @ 220V
 R.P.M.1725
 Bearings.....Shielded and Permanently Lubricated Ball
 SwitchPaddle w/Safety Lock Key

Blade:

Sizes Available1/8" - 1"
 Standard Blade Length.....113"
 Blade Speeds2275, 2720, 3265 F.P.M.

Specifications, while deemed accurate, are not guaranteed.

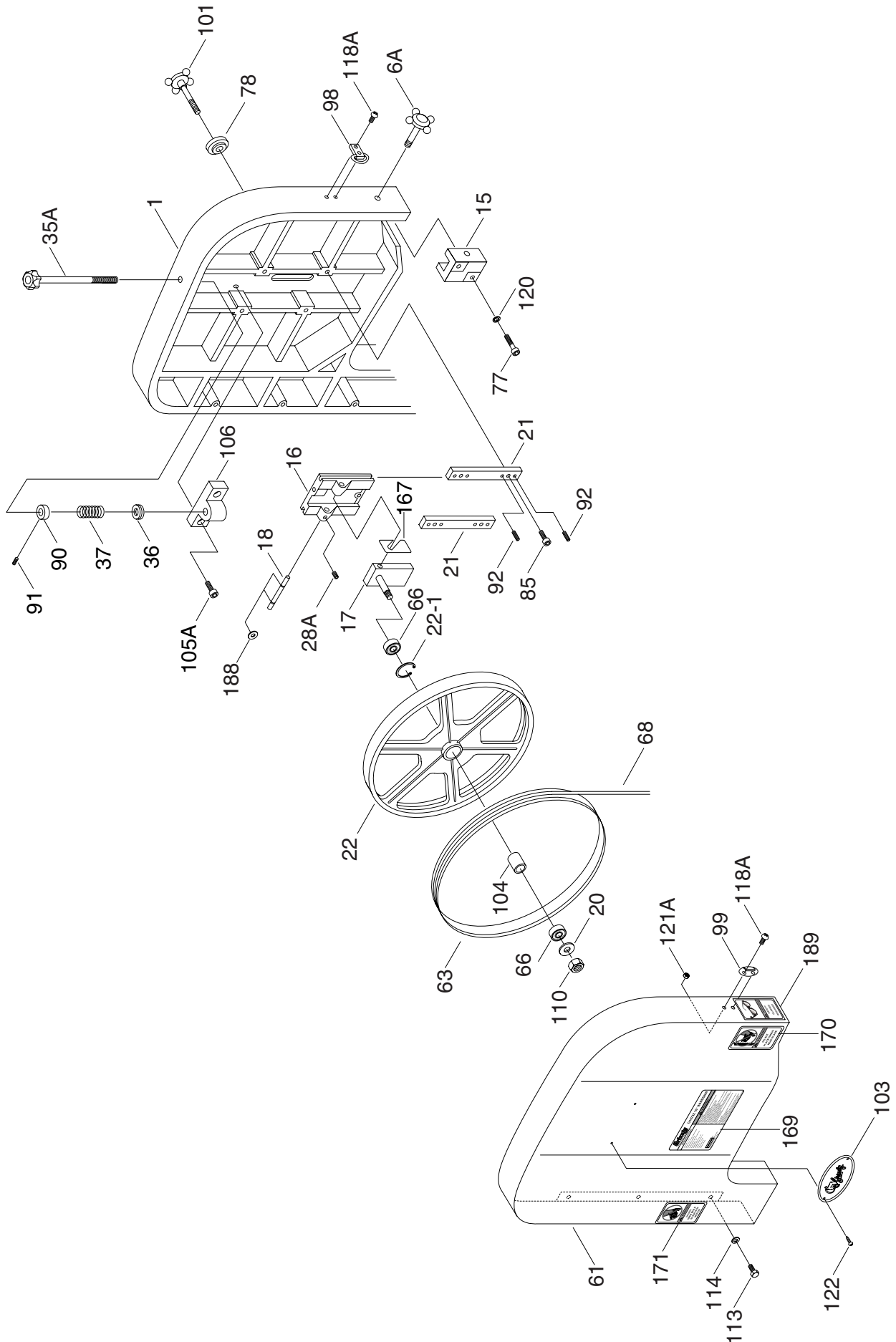

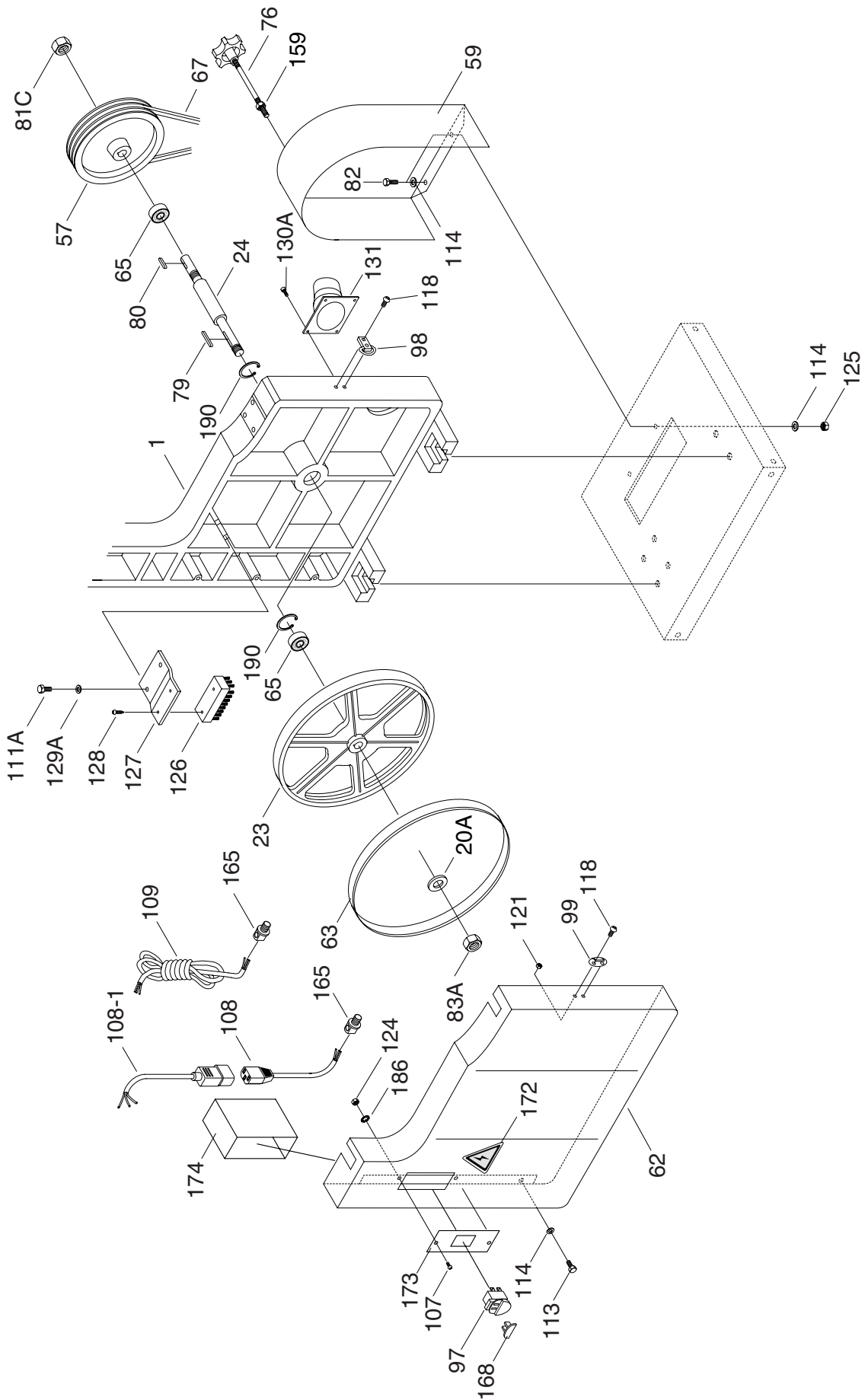

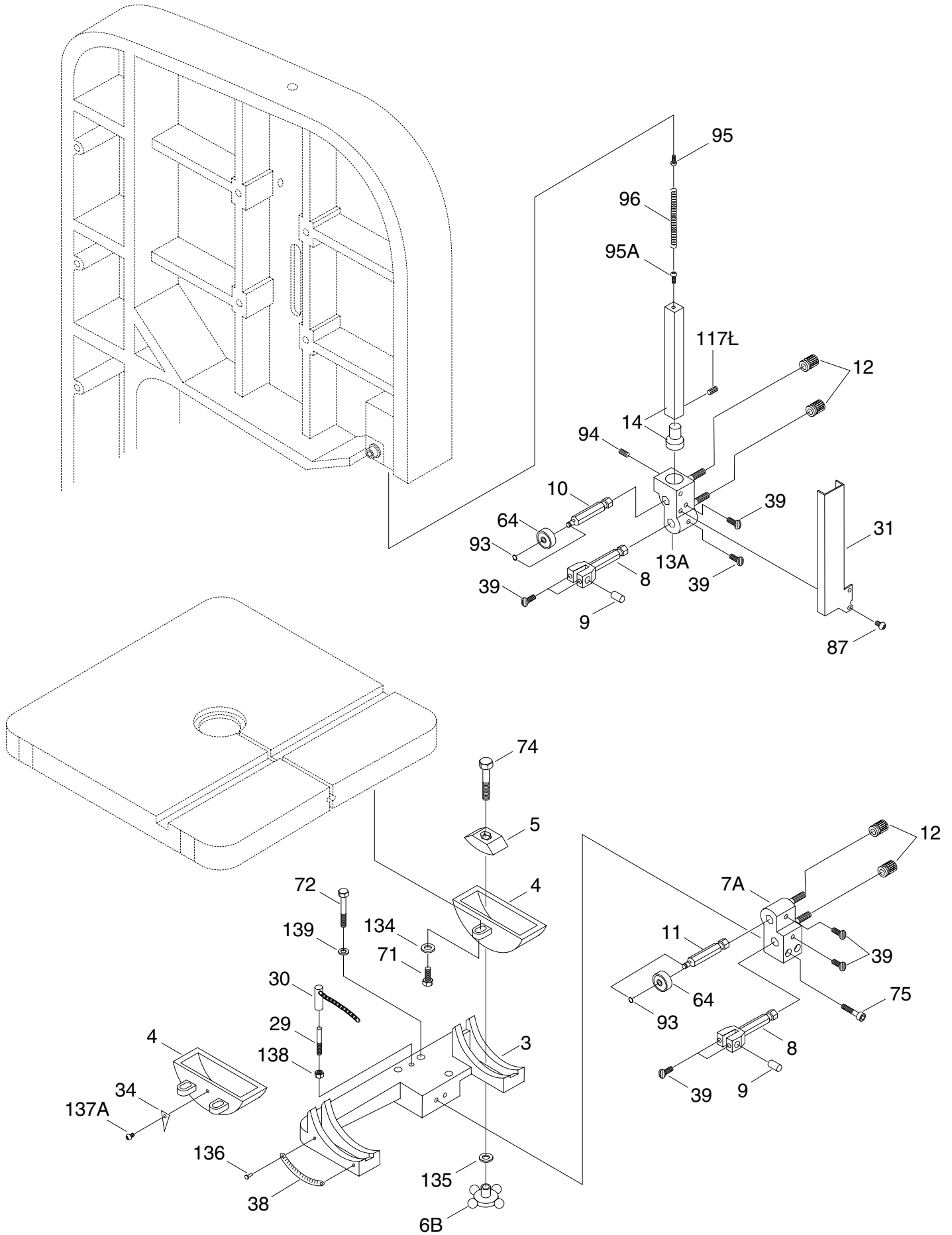

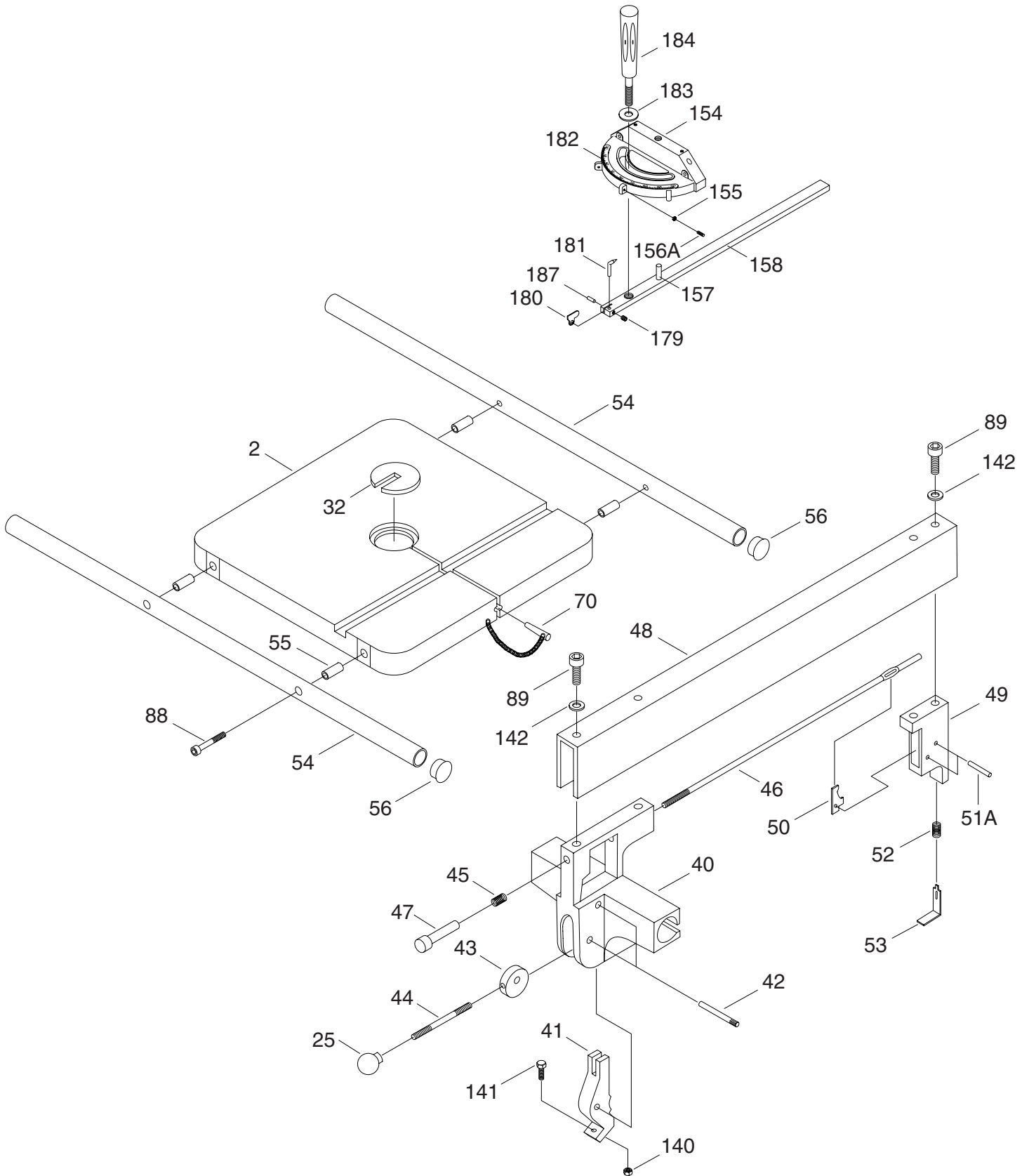

Model 1073

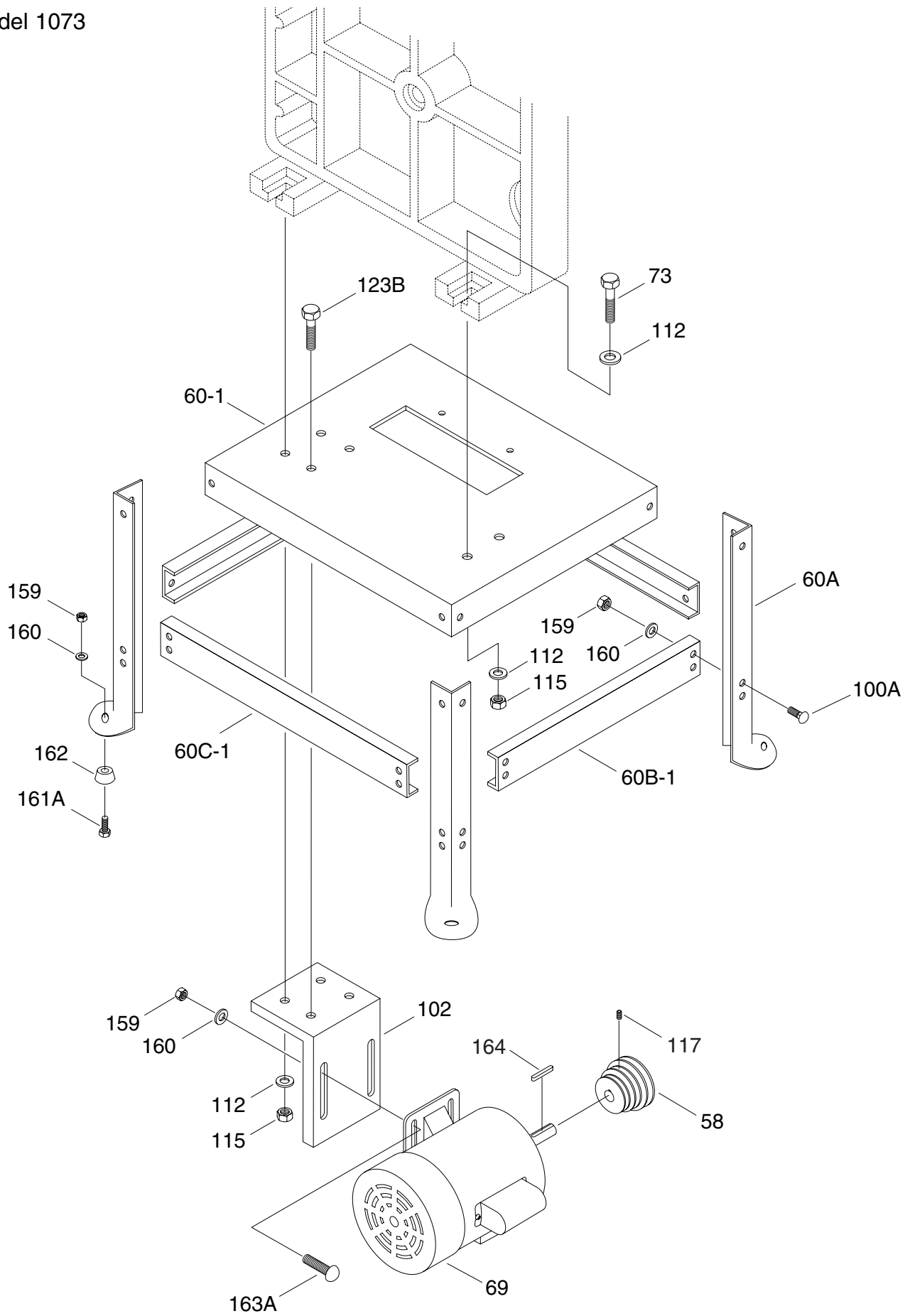

Model 1073Z

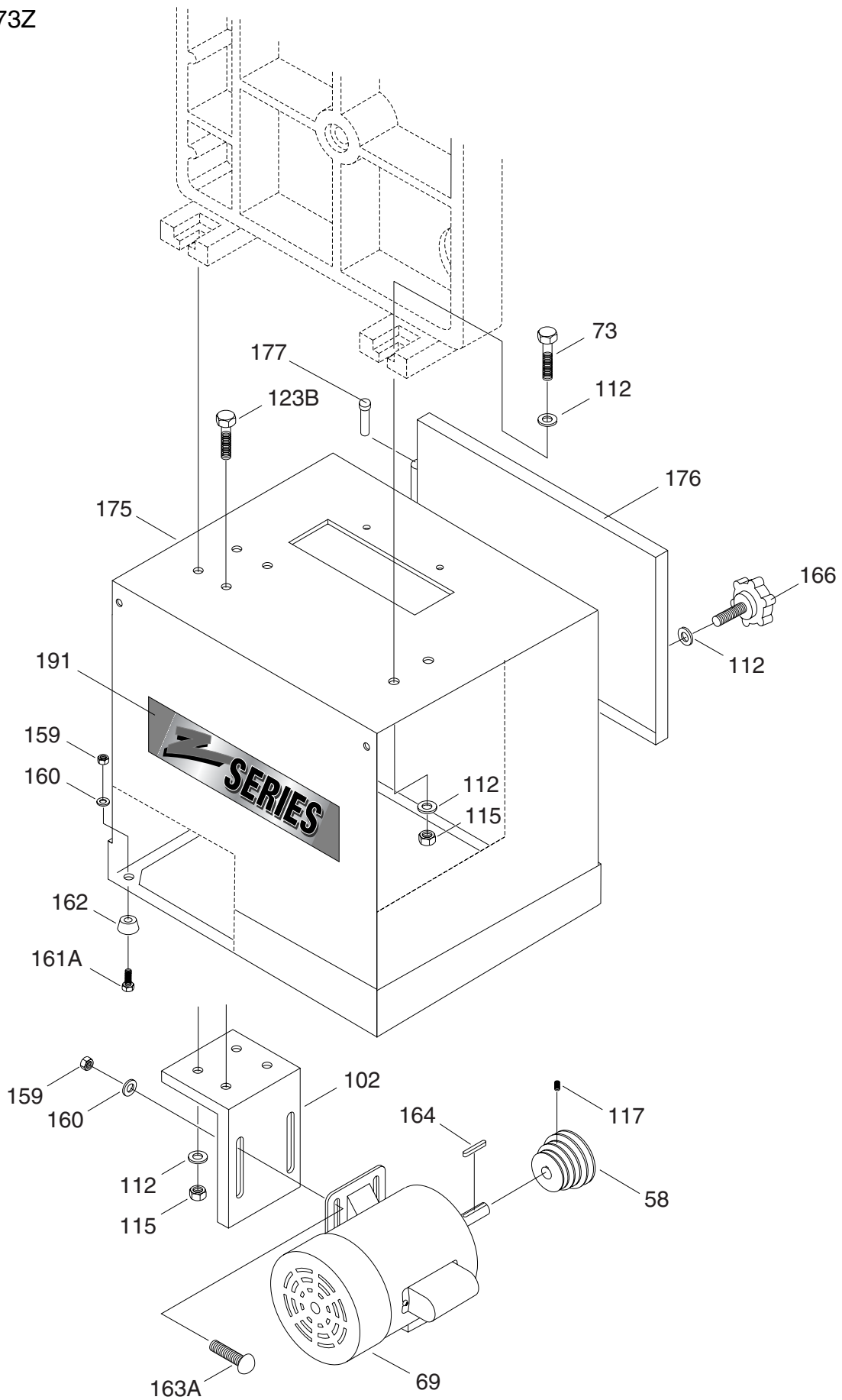

REF	PART #	DESCRIPTION
1	P1073001	MAIN BODY CASTING
2	P1073002	TABLE
3	P1073003	TRUNNION SUPPORT
4	P1073004	TRUNNION
5	P1073005	TRUNNION CLAMP
6A	P1073006A	KNOB SCREW
6B	P1073006B	TRUNNION KNOB
7A	P1073007A	LOWER SUPPORT BRACKET
8	P1073008	GUIDE BLOCK HOLDER
9	P1012008	ROUND GUIDE BLOCK
10	P1073010	BEARING ARBOR, UPPER
11	P1073011	BEARING ARBOR, LOWER
12	P1073012	ADJUST NUT
13A	P1073013A	UPPER SUPPORT BRACKET
14	P1073014	ECCENTRIC GUIDE POST
15	P1073015	GUIDE POST BRACKET
16	P1073016	SLIDING BRACKET
17	P1073017	SHAFT HINGE ASSEMBLY
18	P1073018	STEEL PIN
20	P1073020	SHIM 1/2"
21	P1073021	SLIDING GIB
22	P1073022	UPPER WHEEL
22-1	PR21M	INT RETAINING RING 35MM
23	P1073023	LOWER WHEEL
24	P1073024A	LOWER SHAFT
25	P1073025	KNOB
28	PSS02	SETSCREW 5/16"-18 x 3/8"
29	P1073029	ADJUST SCREW
30	P1073030	ADJUST SCREW CAP
31	P1073031	BLADE GUARD
32	P1073032	TABLE INSERT
34	P1073034	INDICATOR
35A	P1073035A	BLADE TENSION KNOB
36	P51100	THRUST BEARING 51100
37	P1073037	SPRING
38	P1073038	DEGREE PLATE
39	P1073039	THUMB SCREW
40	P1073040	FENCE HEADSTOCK
41	P1073041	CLAMP SHOE
42	P1073042	PIN
43	P1073043	CAM
44	P1073044	HANDLE

REF	PART #	DESCRIPTION
45	P1073045	SPRING
46	P1073046	DRAW BAR
47	P1073047	DRAW BAR NUT
48	P1073048	FENCE
49	P1073049	BLOCK
50	P1073050	LEVER
51A	PRP07M	ROLL PIN 6 X 20MM
52	P1073052	SPRING
53	P1073053	CLAMP HOOK
54	P1073054	GUIDE RAIL
55	P1073055	SPACER
56	P1073056	PLUG
57	P1073057B	PULLEY
58	P1073058A	MOTOR PULLEY
59	P1073059	PULLEY COVER
60-1	P1073060-1	STAND TOP
60A	P1073060A	STAND LEG
60B-1	P1073060B-1	SHORT CROSS BRACE
60C-1	P1073060C-1	LONG CROSS BRACE
61	P1073061	UPPER COVER
62	P1073062	LOWER COVER
63	P1073063	TIRE
64	P6200	BEARING 6200-2RS
65	P6204	BEARING 6204-2RS
66	P6202	BEARING 6202-2RS
67	PVM50	V-BELT M50
68	BLADE	SEE CATALOG
69	P1073069A	MOTOR 2 H.P.
70	P1073070	PIN
71	PB03	HEX BOLT 5/16"-18 x 1"
72	PB06	HEX BOLT 5/16"-18 x 2"
73	PB16	HEX BOLT 3/8"-16 x 2"
74	PB25	HEX BOLT 3/8"-16 x 1 3/4"
75	PSB32	CAP SCREW 1/4"-20 x 1 1/4"
76	P1073076	LOCK KNOB
77A	PB22	HEX BOLT 5/16"-18 x 1 3/4"
78	P1073078	TRACKING LOCK KNOB
79	PK34M	KEY 5 x 5 x 20 mm
80	PK15M	KEY 5 x 5 x 35 mm
81C	PN09	HEX NUT 5/8"-18
82	PB19	HEX BOLT 1/4"-20 x 1/2"
83A	P1073081A	JAM NUT 3/4"-16 LH

REF	PART #	DESCRIPTION
85	PSB07	CAP SCREW 5/16"-18 x 3/4"
87	PS07	PHLP HD SCRW 1/4"-20 x 3/8"
88	PSB32	CAP SCREW 1/4"-20 x 1 1/4"
89	PSB30	CAP SCREW 5/16"-18 x 1/2"
90	P1073090	COLLAR
91	PSS07	SETSCREW 1/4"-20 x 1/2"
92	PSS07	SETSCREW 1/4"-20 x 1/2"
93	PR01M	SNAP RING 10 mm
95A	PS04	PHLP HD SCRW 1/4"-20 x 1/2"
96	P1073096	SPRING
97	PSW06	PADDLE SWITCH
98	P1073098	LATCH
99	P1073099	STRIKE
100A	PCB02	CARRIAGE BOLT 5/16"-18 x 1/2"
101	P1073101	TRACKING KNOB
102	P1073102A	MOTOR MOUNT BRACKET
103	P1073103	LOGO PLATE (MINI)
104	P1073104	BEARING SPACER
105A	PSB01	CAP SCREW 1/4"-20 x 5/8"
106	P1073106	TENSION BRACKET
107	PS22	PHLP HD SCRW 10 - 24 x 5/8"
108	P1073108A	POWER CORD-MALE
109	P1073109A	POWER CORD-FEMALE
110	PN01	HEX NUT 1/2" - 20
111A	PS07	PHLP HD SCR 1/4"-20 X 3/8"
112	PW02	FLAT WASHER 3/8"
113	PB19	HEX BOLT 1/4" - 20 x 1/2"
114	PW06	FLAT WASHER 1/4"
115	PN08	HEX NUT 3/8" - 16
117	PSS07	SETSCREW 1/4" - 20 x 1/2"
118A	PS23	PHLP HD SCRW 10-24 x 1/4"
120	PLW01	LOCK WASHER 5/16"
121A	PN07	HEX NUT 10-24
122	PHTEK1	SELF TAPPING SCREW
123B	PB18	HEX BOLT 3/8" - 16 x 1"
124	PN07	HEX NUT 10 - 24
125	PN05	HEX NUT 1/4" - 20
126	P1073126	BRUSH
127	P1073127	MOUNT BRACKET
128	PHTEK12	TAP SCREW #8 X 1/2"
129A	PW06	FLAT WASHER 1/4"
130A	PS06	PHLP HD SCRW 10-24 x 3/8"
131	G2977	DUST PORT
134	PW07	FLAT WASHER 5/16"
135	PW02	FLAT WASHER 3/8"

REF	PART #	DESCRIPTION
136	P1183108	RIVET
137A	PS23	PHLP HD SCRW 8 - 32 x 1/4"
138A	PN02	HEX NUT 5/16"-18
139	PW07	FLAT WASHER 5/16"
140	PN02	HEX NUT 5/16"-18
141	PB03	HEX BOLT 5/16"-18 x 1"
142	PW07	FLAT WASHER 5/16"
154	P1023403	MITER BODY
155	PN07	HEX NUT 10-24
156A	PSS32	SETSCREW 10-24 x 3/4"
157	P1023SL415	MITER HINGE PIN
158	P1035312A	MITER BAR
159	PN02	HEX NUT 5/16"-18
160	PW07	FLAT WASHER 5/16"
161A	PB03	HEX BOLT 5/16"-18 x 1"
162	P1073162	FOOT
163A	PCB11	CARRIAGE BOLT 5/16"-18 x 1"
164	P1073164A	KEY
165	P1071075	STRAIN RELIEF
166	PR21M	KNOB
167	P1073167	SPACER
168	PSW06A	PADDLE SWITCH KEY
169	P1073169	ID/WARNING LABEL
170	P1073170	HAND/BLADE LABEL
171	P1073171	DON'T OPEN LABEL
172	P1026050	ELECTRICITY LABEL
173	P1073173	SWITCH PLATE
174	P1073174	SWITCH COVER
175	P1073Z175	CABINET
176	P1073Z176	CABINET COVER
177	P1073Z177	HINGE SHAFT
178	P1073178	COMP MITER GAUGE ASSY
179	PSS29	SETSCREW 10-24 X 1/4
180	P1023410	STOP
181	P1023411	POINTER
182	P1023412	SCALE
183	PW06	FLAT WASHER 1/4"
184	1023401A	SCREW TYPE KNOB
186	PTLW01	EXT TOOTH WASHER #10
187	PRP54M	ROLL PIN 1.5 X 3MM
188	PW06	FLAT WASHER 1/4"
189	PLABEL-11	SAFETY GLASSES LABEL
190	PR25M	INT RETAINING RING 47MM
191	PLABEL-5	Z SERIES LABEL

TROUBLESHOOTING

Motor will not start.	<ol style="list-style-type: none"> 1. Low voltage. 2. Open circuit in motor or loose connections. 	<ol style="list-style-type: none"> 1. Check power line for proper voltage. 2. Inspect all lead connections on motor for loose or open connections.
Motor will not start; fuses or circuit breakers blow.	<ol style="list-style-type: none"> 1. Short circuit in line cord or plug. 2. Short circuit in motor or loose connections. 3. Circuit Overloaded 	<ol style="list-style-type: none"> 1. Inspect cord or plug for damaged insulation and shorted wires. 2. Inspect all connections on motor for loose or shorted terminals or worn insulation. 3. Reduce load on circuit.
Motor fails to develop full power (power output of motor decreases rapidly with decrease in voltage at motor terminals).	<ol style="list-style-type: none"> 1. Power line overloaded with lights, appliances, and other motors. 2. Undersized wires or circuits too long. 3. General overloading of power company facilities. 	<ol style="list-style-type: none"> 1. Reduce load on power line. 2. Increase wire sizes or reduce length of wire. 3. Request a power check from the power company.
Motor overheats.	<ol style="list-style-type: none"> 1. Motor overloaded. 2. Air circulation through the motor restricted. 	<ol style="list-style-type: none"> 1. Reduce load on motor. 2. Clean out motor to provide normal air circulation.
Motor stalls (resulting in blown fuses or tripped circuit).	<ol style="list-style-type: none"> 1. Short circuit in motor or loose connections. 2. Low voltage. 3. Incorrect fuses or circuit breakers in power line. 4. Motor overloaded. 	<ol style="list-style-type: none"> 1. Inspect connections on motor for loose or shorted terminals or worn insulation. 2. Correct the low voltage conditions. 3. Install correct fuses or circuit breakers. 4. Reduce load on motor.
Machine slows when operating.	Applying too much pressure to workpiece.	Feed workpiece slower.
Blade does not run evenly on wheels or runs off.	<ol style="list-style-type: none"> 1. Tracking is not adjusted properly. 2. Wheels are not coplanar. 	<ol style="list-style-type: none"> 1. Adjust tracking. 2. Adjust wheel alignment.
Blade does not cut evenly.	<ol style="list-style-type: none"> 1. Blade is not properly tensioned. 2. Wheels are not coplanar. 3. Tooth set is uneven. 4. Teeth are sharper on one side than the other. 	<ol style="list-style-type: none"> 1. Adjust blade tension. 2. Adjust wheel alignment. 3. Skew fence to compensate or replace blade. 4. Skew fence to compensate or replace blade.
Blade slows when cutting. Blade makes a squealing noise, especially on start-up.	<ol style="list-style-type: none"> 1. V-belt loose. 2. V-belt worn out. 	<ol style="list-style-type: none"> 1. Tighten V-belt. 2. Replace V-belt.
Ticking sound when the saw is running.	Weld contacting thrust bearing.	Use the G2516 Stone to smooth and round the back of the blade.
Blade contacting table insert.	<ol style="list-style-type: none"> 1. Excessive side pressure when cutting. 2. Table improperly adjusted. 3. Opening in insert too narrow. 	<ol style="list-style-type: none"> 1. Reduce side pressure. 2. Adjust table. 3. File opening in table insert larger.
Excessive vibration.	<ol style="list-style-type: none"> 1. Rubber pads not installed under stand. 2. Wheels not coplanar. 3. Tires incorrectly installed. 4. Worn out V-belt. 5. Bent or worn out blade. 6. Wheels out of balance. 	<ol style="list-style-type: none"> 1. Install rubber pads under stand. 2. Adjust wheel alignment. 3. Re-install tires. 4. Replace V-belt. 5. Replace blade. 6. Replace wheels.

WARRANTY AND RETURNS

Grizzly Industrial, Inc. warrants every product it sells for a period of **1 year** to the original purchaser from the date of purchase. This warranty does not apply to defects due directly or indirectly to misuse, abuse, negligence, accidents, repairs or alterations or lack of maintenance. This is Grizzly's sole written warranty and any and all warranties that may be implied by law, including any merchantability or fitness, for any particular purpose, are hereby limited to the duration of this written warranty. We do not warrant or represent that the merchandise complies with the provisions of any law or acts unless the manufacturer so warrants. In no event shall Grizzly's liability under this warranty exceed the purchase price paid for the product and any legal actions brought against Grizzly shall be tried in the State of Washington, County of Whatcom.

We shall in no event be liable for death, injuries to persons or property or for incidental, contingent, special, or consequential damages arising from the use of our products.

To take advantage of this warranty, contact us by mail or phone and give us all the details. We will then issue you a "Return Number," which must be clearly posted on the outside as well as the inside of the carton. We will not accept any item back without this number. Proof of purchase must accompany the merchandise.

The manufacturers reserve the right to change specifications at any time because they constantly strive to achieve better quality equipment. We make every effort to ensure that our products meet high quality and durability standards and we hope you never need to use this warranty.

Please feel free to write or call us if you have any questions about the machine or the manual.

Thank you again for your business and continued support. We hope to serve you again soon.

WARRANTY CARD

Name _____
 Street _____
 City _____ State _____ Zip _____
 Phone Number _____ E-Mail _____ FAX _____
 MODEL _____ Order # _____

The following information is given on a voluntary basis. It will be used for marketing purposes to help us develop better products and services. Of course, all information is strictly confidential.

CUT ALONG DOTTED LINE

1. How did you learn about us?

<input type="checkbox"/> Advertisement <input type="checkbox"/> Catalog <input type="checkbox"/> World Wide Web <input type="checkbox"/> Other _____	<input type="checkbox"/> Friend <input type="checkbox"/> Card Deck
---	---
2. Which of the following magazines do you subscribe to.

<input type="checkbox"/> American Woodworker <input type="checkbox"/> Cabinetmaker <input type="checkbox"/> Family Handyman <input type="checkbox"/> Fine Homebuilding <input type="checkbox"/> Fine Woodworking <input type="checkbox"/> Home Handyman <input type="checkbox"/> Journal of Light Construction <input type="checkbox"/> Old House Journal <input type="checkbox"/> Popular Mechanics <input type="checkbox"/> Popular Science <input type="checkbox"/> Popular Woodworking <input type="checkbox"/> Other _____	<input type="checkbox"/> Practical Homeowner <input type="checkbox"/> Shop Notes <input type="checkbox"/> Today's Homeowner <input type="checkbox"/> WOOD <input type="checkbox"/> Wooden Boat <input type="checkbox"/> Woodshop News <input type="checkbox"/> Woodsmith <input type="checkbox"/> Woodwork <input type="checkbox"/> Woodworker <input type="checkbox"/> Woodworker's Journal <input type="checkbox"/> Workbench
--	---
3. Which of the following woodworking/remodeling shows do you watch?

<input type="checkbox"/> Backyard America <input type="checkbox"/> Home Time <input type="checkbox"/> The American Woodworker <input type="checkbox"/> Other _____	<input type="checkbox"/> The New Yankee Workshop <input type="checkbox"/> This Old House <input type="checkbox"/> Woodwright's Shop
---	---
4. What is your annual household income?

<input type="checkbox"/> \$20,000-\$29,999 <input type="checkbox"/> \$30,000-\$39,999 <input type="checkbox"/> \$40,000-\$49,999 <input type="checkbox"/> \$50,000-\$59,999	<input type="checkbox"/> \$60,000-\$69,999 <input type="checkbox"/> \$70,000-\$79,999 <input type="checkbox"/> \$80,000-\$89,999 <input type="checkbox"/> \$90,000 +
--	---
5. What is your age group?

<input type="checkbox"/> 20-29 <input type="checkbox"/> 30-39 <input type="checkbox"/> 40-49	<input type="checkbox"/> 50-59 <input type="checkbox"/> 60-69 <input type="checkbox"/> 70 +
--	---
6. How long have you been a woodworker?

<input type="checkbox"/> 0 - 2 Years <input type="checkbox"/> 2 - 8 Years	<input type="checkbox"/> 8 - 20 Years <input type="checkbox"/> 20+ Years
--	---
7. How would you rank your woodworking skills?

<input type="checkbox"/> Simple <input type="checkbox"/> Intermediate	<input type="checkbox"/> Advanced <input type="checkbox"/> Master Craftsman
--	--
8. What stationary woodworking tools do you own? Check all that apply.

<input type="checkbox"/> Air Compressor <input type="checkbox"/> Band Saw <input type="checkbox"/> Drill Press <input type="checkbox"/> Drum Sander <input type="checkbox"/> Dust Collector <input type="checkbox"/> Horizontal Boring Machine <input type="checkbox"/> Jointer <input type="checkbox"/> Lathe <input type="checkbox"/> Mortiser	<input type="checkbox"/> Panel Saw <input type="checkbox"/> Planer <input type="checkbox"/> Power Feeder <input type="checkbox"/> Radial Arm Saw <input type="checkbox"/> Shaper <input type="checkbox"/> Spindle Sander <input type="checkbox"/> Table Saw <input type="checkbox"/> Vacuum Veneer Press <input type="checkbox"/> Wide Belt Sander
--	--
9. How many of your woodworking machines are Grizzly? _____
 Other _____
10. Which benchtop tools do you own? Check all that apply.

<input type="checkbox"/> 1" x 42" Belt Sander <input type="checkbox"/> 5" - 8" Drill Press <input type="checkbox"/> 8" Table Saw <input type="checkbox"/> 8" - 10" Bandsaw <input type="checkbox"/> Disc/Belt Sander <input type="checkbox"/> Mini Jointer <input type="checkbox"/> Other _____	<input type="checkbox"/> 6" - 8" Grinder <input type="checkbox"/> Mini Lathe <input type="checkbox"/> 10" - 12" Thickness Planer <input type="checkbox"/> Scroll Saw <input type="checkbox"/> Spindle/Belt Sander
---	---
11. How many of the machines checked above are Grizzly? _____
12. Which portable/hand held power tools do you own? Check all that apply.

<input type="checkbox"/> Belt Sander <input type="checkbox"/> Biscuit Joiner <input type="checkbox"/> Circular Saw <input type="checkbox"/> Detail Sander <input type="checkbox"/> Drill/Driver <input type="checkbox"/> Miter Saw <input type="checkbox"/> Other _____	<input type="checkbox"/> Orbital Sander <input type="checkbox"/> Palm Sander <input type="checkbox"/> Portable Planer <input type="checkbox"/> Saber Saw <input type="checkbox"/> Reciprocating Saw <input type="checkbox"/> Router
---	--
13. What machines/supplies would you like Grizzly Industrial to carry?

<input type="checkbox"/> 12" Table Saw <input type="checkbox"/> 12" Jointer <input type="checkbox"/> Combination Planer/Jointer <input type="checkbox"/> Paint & Finishing Supplies <input type="checkbox"/> Contractor's Supplies <input type="checkbox"/> Other _____	<input type="checkbox"/> Radial Arm Saw <input type="checkbox"/> Panel Saw <input type="checkbox"/> Brass Hardware <input type="checkbox"/> Lumber
--	---
14. What new accessories would you like Grizzly Industrial to carry?

<input type="checkbox"/> Builders Hardware <input type="checkbox"/> Fasteners <input type="checkbox"/> Other _____	<input type="checkbox"/> Hand Tools <input type="checkbox"/> Wood Components
--	---
15. What other companies do you purchase your tools and supplies from?

16. Do you think your purchase represents good value?
 Yes No
17. Would you recommend Grizzly Industrial to a friend?
 Yes No
18. Would you allow us to use your name as a reference for Grizzly customers in your area? **Note: We never use names more than three times.**
 Yes No
19. Comments: _____

FOLD ALONG DOTTED LINE



Place
Stamp
Here



GRIZZLY INDUSTRIAL, INC.
P.O. BOX 2069
BELLINGHAM, WA 98227-2069



FOLD ALONG DOTTED LINE

Send a Grizzly Catalog to a friend:

Name _____
Street _____
City _____ State _____ Zip _____

TAPE ALONG EDGES--PLEASE DO NOT STAPLE

Free Manuals Download Website

<http://myh66.com>

<http://usermanuals.us>

<http://www.somanuals.com>

<http://www.4manuals.cc>

<http://www.manual-lib.com>

<http://www.404manual.com>

<http://www.luxmanual.com>

<http://aubethermostatmanual.com>

Golf course search by state

<http://golfingnear.com>

Email search by domain

<http://emailbydomain.com>

Auto manuals search

<http://auto.somanuals.com>

TV manuals search

<http://tv.somanuals.com>