

# Grizzly<sup>®</sup>

## Industrial, Inc.

### MODEL T26416

### 18-GAUGE 1/4" CROWN STAPLER

### OWNER'S MANUAL

*(For models manufactured since 10/13)*



COPYRIGHT © OCTOBER, 2013 BY GRIZZLY INDUSTRIAL, INC.  
**WARNING: NO PORTION OF THIS MANUAL MAY BE REPRODUCED IN ANY SHAPE OR FORM WITHOUT THE WRITTEN APPROVAL OF GRIZZLY INDUSTRIAL, INC.**  
#DM16015 PRINTED IN TAIWAN

V1.10.13



## **WARNING!**

This manual provides critical safety instructions on the proper setup, operation, maintenance, and service of this machine/tool. Save this document, refer to it often, and use it to instruct other operators.

Failure to read, understand and follow the instructions in this manual may result in fire or serious personal injury—including amputation, electrocution, or death.

The owner of this machine/tool is solely responsible for its safe use. This responsibility includes but is not limited to proper installation in a safe environment, personnel training and usage authorization, proper inspection and maintenance, manual availability and comprehension, application of safety devices, cutting/sanding/grinding tool integrity, and the usage of personal protective equipment.

The manufacturer will not be held liable for injury or property damage from negligence, improper training, machine modifications or misuse.



## **WARNING!**

Some dust created by power sanding, sawing, grinding, drilling, and other construction activities contains chemicals known to the State of California to cause cancer, birth defects or other reproductive harm. Some examples of these chemicals are:

- Lead from lead-based paints.
- Crystalline silica from bricks, cement and other masonry products.
- Arsenic and chromium from chemically-treated lumber.

Your risk from these exposures varies, depending on how often you do this type of work. To reduce your exposure to these chemicals: Work in a well ventilated area, and work with approved safety equipment, such as those dust masks that are specially designed to filter out microscopic particles.

# Table of Contents

<b>SECTION 1: SAFETY</b> .....	<b>2</b>
Safety Instructions for Pneumatic Tools .....	3
<b>SECTION 2: INTRODUCTION</b> .....	<b>5</b>
Foreword .....	5
Specifications .....	5
<b>SECTION 3: SET UP</b> .....	<b>6</b>
Unpacking .....	6
Inventory .....	6
Loading Staples .....	7
Air Deflection .....	7
Compressed Air System .....	8
Test Run .....	9
<b>SECTION 4: OPERATIONS</b> .....	<b>10</b>
<b>SECTION 5: ACCESSORIES</b> .....	<b>11</b>
<b>SECTION 6: MAINTENANCE</b> .....	<b>12</b>
Cleaning .....	12
Lubricating .....	12
<b>SECTION 7: SERVICE</b> .....	<b>13</b>
Replacing O-Rings & Piston Assemblies .....	13
Troubleshooting .....	14
Parts .....	15
<b>WARRANTY</b> .....	<b>17</b>

# SECTION 1: SAFETY

## **WARNING**

### **For Your Own Safety Read Instruction Manual Before Operating This Equipment**

The purpose of safety symbols is to attract your attention to possible hazardous conditions. This manual uses a series of symbols and signal words which are intended to convey the level of importance of the safety messages. The progression of symbols is described below. Remember that safety messages by themselves do not eliminate danger and are not a substitute for proper accident prevention measures.

 **DANGER** Indicates an imminent hazardous situation which, if not avoided, **WILL** result in death or serious injury.

 **WARNING** Indicates a potentially hazardous situation which, if not avoided, **COULD** result in death or serious injury.

 **CAUTION** Indicates a potentially hazardous situation which, if not avoided, **MAY** result in minor or moderate injury. It may also be used to alert against unsafe practices.

**NOTICE** This symbol is used to alert the user to useful information about proper operation of the equipment.

## **WARNING**

### **Safety Instructions For Pneumatic Tools**

**KEEP ALL SAFETY DEVICES IN PLACE** and in working order.

**REMOVE ADJUSTING KEYS AND WRENCHES.** Form habit of checking to see that keys and adjusting wrenches are removed from tool before operation.

**KEEP WORK AREA CLEAN.** Cluttered areas and benches invite accidents.

**DO NOT USE IN DANGEROUS ENVIRONMENT.** Do not use pneumatic tools in damp or wet locations, or where any flammable or noxious fumes may exist. Keep work area well lighted.

**KEEP CHILDREN AND VISITORS AWAY.** All children and visitors should be kept at a safe distance from work area.

**MAKE WORKSHOP CHILD PROOF** by locking the shop and shutting off air valves.

**DO NOT FORCE TOOL.** It will do the job better and safer at the rate for which it was designed.

**USE THE RIGHT TOOL.** Do not force tool or attachment to do a job for which it was not designed.

**DO NOT USE UNDER THE INFLUENCE OF DRUGS OR ALCOHOL.**

# WARNING

## Safety Instructions for Pneumatic Tools

**USE PROPER AIR HOSE** for the tool. Make sure your air hose is in good condition and is long enough to reach your work without stretching.

**WEAR PROPER APPAREL.** Do not wear loose clothing, gloves, neckties, rings, bracelets, or other jewelry which may get caught in moving parts. Non-slip footwear is recommended. Wear a protective hair covering to contain long hair.

**ALWAYS USE SAFETY GLASSES.** Also use a face or dust mask if operation is dusty. Everyday eyeglasses only have impact resistant lenses, they are NOT safety glasses.

**WEAR APPROVED HEARING PROTECTION.** Air escaping from pneumatic tools can exceed safe exposure limits and may cause hearing damage with prolonged exposure.

**AWKWARD POSITIONS.** Keep proper footing and balance at all times when operating tool. Do not overreach! Avoid awkward hand positions that make workpiece control difficult or increase the risk of accidental injury.

**REDUCE THE RISK OF UNINTENTIONAL FIRING.** Do not carry tool with hand on trigger and always disconnect from air when not in use.

**CHECK FOR DAMAGED PARTS.** Regularly inspect tool for any condition that may affect safe operation. Immediately repair or replace damaged or mis-adjusted parts before operating tool.

**DISCONNECT TOOLS** before servicing, changing accessories, or moving to another location.

**USE RECOMMENDED ACCESSORIES.** Consult this owner's manual or the manufacturer for recommended accessories. Using improper accessories will increase the risk of serious injury.

**NEVER LEAVE UNATTENDED TOOL CONNECTED TO AIR.** Disconnect the air hose and do not leave tool until it is relieved of any built up pressure.

**NEVER ALLOW UNTRAINED USERS TO USE THIS TOOL WHILE UNSUPERVISED.**

**IF YOU ARE UNSURE OF THE INTENDED OPERATION, STOP USING TOOL.** Seek formal training or research books or magazines that specialize in pneumatic tools.

**BE AWARE OF HOSE LOCATION WHEN USING PNEUMATIC TOOLS.** Hoses can easily become a tripping hazard when laid across the floor or spread out in a disorganized fashion.

**SECURE WORK.** When required, use clamps or vises to secure workpiece. A secured workpiece protects hands and frees both of them to operate the tool.

**MAINTAIN TOOLS WITH CARE.** Keep tools lubricated and clean for best and safest performance. Follow instructions for lubricating and changing accessories.

# WARNING

## Additional Safety for Staplers

**HAND INJURIES.** Do not place your hands near the staple point of entry. A staple can deflect and tear through the surface of the workpiece, puncturing your hand or fingers.

**SAFE HANDLING.** Never point the stapler at others! Do not keep the trigger pulled when loading fasteners, carrying, or holding tool. Carry the stapler only by the handle, never by any other part. Do not carry the stapler by the air hose. Disconnect the stapler from the air hose when going up and down ladders.

**MODIFICATIONS.** DO NOT modify this tool or bypass the safety nose mechanism.

**COMBUSTIBLE GASES.** Never connect the stapler to pressurized oxygen or other combustible gases as a power source. Only use filtered, lubricated, and regulated compressed air.

**COMPRESSED AIR RATING.** Do not connect the stapler to compressed air that exceeds 120 PSI.

**HOSE USAGE.** Make sure the air hose is designed for the tool in use, is in good condition, and is long enough to reach the work without stretching. However, an overly long air hose in the work area may be a tripping hazard.

**MAINTENANCE.** Always disconnect air from the stapler when servicing or installing staples. During maintenance, a stapler connected to air may fire accidentally, causing serious personal injury.

**CHECK VALVE.** Do not use a check valve or any other fitting that allows air to remain in the tool.

**CLEANING.** Never use gasoline or other flammable liquids to clean the stapler; vapors in the stapler will ignite by a spark and cause it to explode.

**OPERATING QUESTIONS.** If you are not sure about the intended operation, stop using the stapler. Seek formal training or research books or magazines that specialize in pneumatic tools.

# SECTION 2: INTRODUCTION

---

---

## Foreword

---

---

We are proud to offer this manual! We've made every effort to be exact with the instructions, specifications, drawings, and photographs we used when writing this manual. However, sometimes we still make an occasional mistake.

Also, owing to our policy of continuous improvement, your stapler may not exactly match the manual. If you find this to be the case, and the difference between the manual and stapler leaves you in doubt, check our website for the latest manual update or call technical support for help.

For your convenience, we post all available manuals and manual updates for free on our website at [www.grizzly.com](http://www.grizzly.com). Any updates to this model of tool will be reflected in these documents as soon as they are complete.

## Contact Info

---

---

We stand behind our tools. If you have any service questions, parts requests or general questions about the tool, please call or write us at the location listed below.

Grizzly Industrial, Inc.  
1203 Lycoming Mall Circle  
Muncy, PA 17756  
Phone: (570) 546-9663  
E-Mail: [techsupport@grizzly.com](mailto:techsupport@grizzly.com)

We want your feedback on this manual. If you can take the time, please email or write to us at the address below and tell us how we did:

Grizzly Industrial, Inc.  
C/O Technical Documentation Manager  
P.O. Box 2069  
Bellingham, WA 98227-2069  
Email: [manuals@grizzly.com](mailto:manuals@grizzly.com)

## Specifications

---

---

Operating Pressure .....	70–120 PSI
Staple Size .....	18 Gauge
Staple Length .....	½"–1"
Staple Crown .....	¼"
Magazine Capacity .....	100 Staples

# SECTION 3: SET UP

## Unpacking

This Stapler was carefully packaged for safe transportation. Remove the packaging materials from around this tool and inspect it. If you discover the tool is damaged, *please immediately call Customer Service at (570) 546-9663 for advice.*

Save the containers and all packing materials for possible inspection by the carrier or its agent. Otherwise, filing a freight claim can be difficult.

When you are completely satisfied with the condition of the shipment, inventory the contents.

If any non-proprietary parts are missing (e.g., a nut or a washer), we will gladly replace them; or for the sake of expediency, replacements can be obtained at your local hardware store.

## Inventory

Model T26416 Inventory	Qty
A. Crown Stapler .....	1
B. Hex Wrench 3mm .....	1
C. Hex Wrench 4mm .....	1
D. Bottle for Oil .....	1

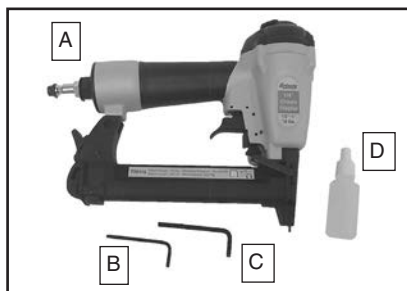
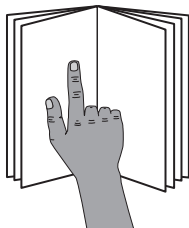

Figure 1. Inventory.

## ⚠ WARNING



**This Stapler presents serious injury hazards to untrained users. Read through this entire manual to become familiar with the controls and operations before starting the tool!**



# Loading Staples

---

---

Use the following specifications when obtaining staples for this stapler:

Gauge..... 18  
Length..... 1/2" to 1"  
Capacity..... 100  
Crown ..... 1/4"

To load the stapler:

1. DISCONNECT STAPLER FROM AIR SUPPLY!
2. Grip the stapler firmly, unlock the quick release latch and pull the pusher back (see **Figure 2**).



**Figure 2.** Example of unlocking quick release latch.

3. With the stapler pointing up, insert a stick of staples (pointing outward) into the magazine, as shown in **Figure 3**.



**Figure 3.** Example of inserting staples into magazine.

4. Slide the magazine pusher and the stick of staples towards the nose of the stapler until the quick-release latch locks.

## Air Deflection

---

---

This stapler is equipped with an air deflector that rotates 360 degrees. Prior to using the stapler, adjust the deflector to direct released air away from yourself and others (see **Figure 4**).



**Figure 4.** Air deflector.

# Compressed Air System

---

---

The Model T26416 is designed to be operated at 70-120 PSI using clean, dry, regulated, compressed air. **DO NOT exceed the 120 PSI maximum operating pressure for your model.**

Before using your new stapler, regulate the air pressure on your air compressor to the minimum PSI for your model.

An in-line filter/lubricator/regulator unit, depicted in **Figure 5**, can be installed and should be located as close to the stapler as possible.

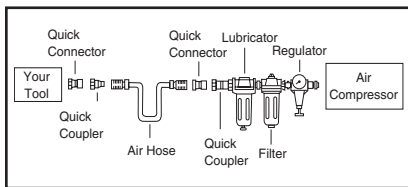

**Figure 5.** Installed filter lubricator regulator.

This filter/lubricator/regulator unit will protect your tool from damaging water build-up, allow you to adjust and maintain constant air pressure to your tool, and save you the inconvenience of having to manually lubricate your tool every time you use it.

Check the current Grizzly catalog for availability of this unit. If you plan on installing a filter/lubricator/regulator unit in your compressed air system, always follow the connection instructions that come with the unit.

# Test Run

---

---

Prior to using the stapler for regular operations, perform this test run procedure on a scrap workpiece at least 1½" thick to ensure it functions properly.

## To test run stapler:

1. Insert staples into stapler, following directions in **Loading Staples** section.
2. Firmly holding stapler with nose pointing away from you and others, connect stapler to air supply.
3. Clamp the scrap workpiece to a workstation.
4. Press the stapler against the scrap workpiece and fully depress the safety probe (see **Figure 6**).

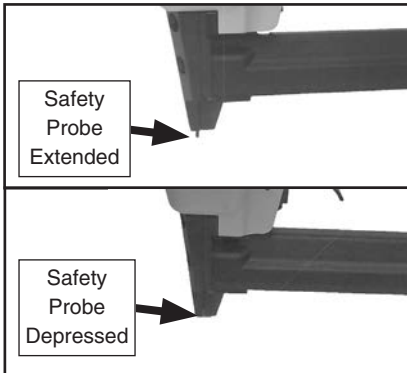

**Figure 6.** Safety probe depressed.

5. Pull the trigger on the stapler.
6. Inspect scrap piece to ensure staple was driven correctly.
7. As a one time test of the safety mechanism, pull the stapler back from the scrap piece until the safety probe is no longer depressed. Angle the stapler so the ricochet trajectory is away from you and others, then pull the trigger.

— If the stapler did not fire then the safety mechanism is working correctly.

— If the stapler did fire, the safety mechanism is not working correctly. Carefully disconnect the air supply and contact tech support to resolve the problem before using the stapler any further.

# SECTION 4: OPERATIONS

## ⚠️ WARNING



**EYE INJURY HAZARD!**  
Wear safety glasses when using this tool.

## ⚠️ WARNING



**LUNG/EAR INJURY HAZARD!**  
Wear protective equipment when using this tool.

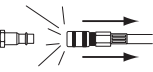

**ACCIDENTAL START HAZARD!**  
Disconnect before service or staple replacement.



**AIR PRESSURE HAZARD!**  
Never exceed max PSI rating for tool.

## ⚠️ WARNING



Deflection due to material irregularities can cause puncture injuries to improperly placed hands or body parts. Always position hands and body away from staple trajectory and deflection paths.

The purpose of this overview is to provide the novice tool operator with a basic understanding of how the tool is used.

### To perform a typical operation:

1. DISCONNECT STAPLER FROM AIR SUPPLY!
2. Check to ensure there are enough staples in the magazine and reconnect to air supply.
3. Drive a staple into a scrap piece of the same material, and inspect the depth of the driven staple.

If the staple was not driven in the correct depth, use the depth adjustment wheel to properly set the staple depth (see **Figure 7**). Rotating the wheel clockwise (from the backside) increases the depth, while rotating counter-clockwise decreases the depth.

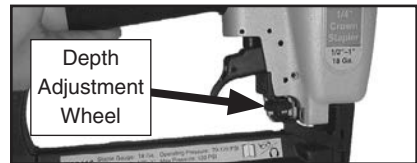

**Figure 7.** Depth adjustment wheel.

4. Align workpieces to be stapled.
5. Place safety probe  $\frac{1}{8}$ " above the staple insertion target, and push down the stapler until it is butted up against and perpendicular with the bottom workpiece.
6. Before pulling the trigger, make sure your free hand and other body parts are out of staple trajectory or deflection paths.
7. Pull the trigger.

# SECTION 5: ACCESSORIES

## **⚠️ WARNING**

Installing unapproved accessories may cause stapler to malfunction, resulting in serious personal injury or tool damage. To reduce this risk, only install accessories recommended for this tool by Grizzly.

## **NOTICE**

Refer to our website or latest catalog for additional recommended accessories.

**G6052—18 Gauge 1/4" Crown Galv. - 1/2"**

**G6053—18 Gauge 1/4" Crown Galv. - 5/8"**

**G6054—18 Gauge 1/4" Crown Galv. - 3/4"**

**G6055—18 Gauge 1/4" Crown Galv. - 7/8"**

**G6056—18 Gauge 1/4" Crown Galv. - 1"**

Stay stocked up on staples with these 5000 piece packages.

**T20451—"Kirova" Clear Safety Glasses**

**H7194—Bifocal Safety Glasses 1.5**

**H7195—Bifocal Safety Glasses 2.0**

**H7196—Bifocal Safety Glasses 2.5**



**Figure 8.** Safety glasses.

## **T22456—Bostitch Pneumatic Lubricant**

This Premium Grade Pneumatic Tool Lubricant is specially formulated for pneumatic tools and blended using premium grade turbine oil. Contains rust and oxidation inhibitors to prevent degradation of tool components.



**Figure 9.** Pneumatic tool lubricant.

## **H4979—Twin Cup Hearing Protector**

Optime III is a super-muff, and has been developed for use in extremely noisy environments. The hearing protection is based on a technology with a double casing that minimizes resonance in the holder casing.



**Figure 10.** Hearing protection.

**Call 1-800-523-4777 To Order**

# SECTION 6: MAINTENANCE

## Cleaning

Disconnect the stapler from the air supply before cleaning. Use a good solvent to clean the nose assembly of the stapler. Always be sure that the stapler is dry before using it again.

Do not allow dust, chips, sand, etc. into the air connectors or into the body of the stapler; this may result in leaks and damage to the stapler and the air couplings.

### **WARNING**



**Never use gasoline or other flammable liquids to clean this tool. Vapors in the tool may ignite, causing the tool to explode. Ignoring this warning may lead to serious personal injury or even death!**

## Lubricating

Place two to six drops of pneumatic tool oil in the nailer air inlet (as shown in **Figure 11**) every 2 hours of continuous use. Wipe off any excess oil near the nailer exhaust to avoid dust build-up.

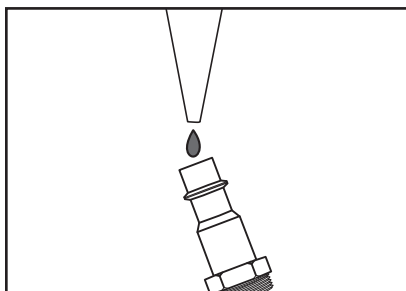
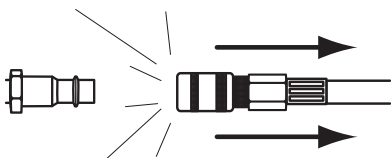

**Figure 11.** Lubricating stapler via air inlet.

Another option to manual oiling would be to simply install a lubricator in your air compressor line. If your air compressor line already has a lubricator, then regular lubrication of your nailer will not be necessary. Just make sure there is always oil in the lubricator.

# SECTION 7: SERVICE

## WARNING



Always disconnect air from stapler whenever servicing! During maintenance, a stapler connected to air may fire accidentally, causing serious personal injury!

## Replacing O-Rings & Piston Assemblies

If you use your stapler frequently, replacement piston assemblies (part PT26416112A) and O-ring kits (part PT26416428) are cheap insurance against wasted down time and lost profits, in the event that the piston assembly or an O-ring becomes worn out.

### To replace piston assembly:

1. DISCONNECT STAPLER FROM AIR SUPPLY!
2. Remove all staples from the magazine cartridge.
3. Remove the four cap screws on the cylinder cap of the stapler, near the exhaust port.
4. Remove the cap.
5. Pull back the pusher revealing the magazine compartment.
6. Being careful not to scratch the sides of the driver guide, insert a slim and sturdy piece of metal through the hole at the top of the magazine compartment (see **Figure 12**), and push the piston assembly out the back of the cylinder.
7. Place a thin film of the stapler lubricating oil on the O-ring of the piston assembly.
8. Insert the new piston assembly into the cylinder. Make sure that the end of the driver on the piston assembly lines up with the slit at the bottom of the cylinder. The new piston assembly should easily slide into the cylinder. **DO NOT force the piston assembly into the cylinder!** If it is not easily inserted, double-check the alignment of the driver end with the slit.
9. After the piston assembly is inserted correctly, close the magazine pusher. Replace the cylinder cap assembly and tighten the 4 cap screws.
10. For more assistance, or to install a complete O-ring set, refer to the appropriate breakdown diagram in the back of this manual for component locations.

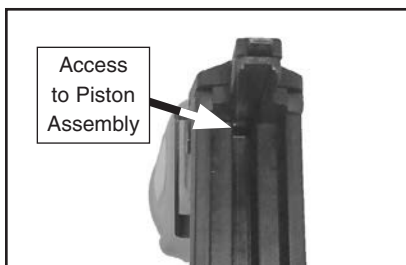

**Figure 12.** Piston assembly access through magazine compartment.

# Troubleshooting

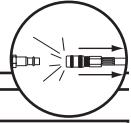

Symptom	Possible Cause	Solution
Air leaking at trigger valve area.	1. O-rings in trigger valve housing are damaged.	1. O-rings must be replaced & operation of safety probe must be checked.
Air leaking between housing and hose.	1. Loose screws in housing. 2. Damaged O-ring. 3. Loose air fitting.	1. Tighten screws. 2. Replace O-ring. 3. Tighten air fitting & use teflon tape.
Air leaking between housing and cap assembly.	1. Damaged seal.	1. Replace damaged seals.
Tool skips staples while discharging.	1. Air leaks. 2. Dirt in nose. 3. Dirt or damage prevents staples from moving freely in magazine. 4. Inadequate air flow to tool.  5. Worn O-ring on piston or lack of lubrication. 6. Damaged O-rings on trigger valve. 7. Cap seal leaking.	1. Tighten screws and fittings. 2. Clean nose. 3. Clean magazine and inspect/repair damage.  4. Check fitting, hose, compressor & air pressure. 5. Replace piston O-ring. Lubricate. 6. Replace trigger valve O-rings. 7. Replace cap seal.
Tool runs slowly or has a loss of power.	1. Stapler is not sufficiently lubricated. 2. Broken spring in cap assembly. 3. Exhaust port in cap is blocked.	1. Lubricate stapler. 2. Replace spring. 3. Clean or replace damaged internal parts.
Fasteners frequently jam the stapler.	1. Staples are the wrong size. 2. Staples are bent or dirty.  3. Magazine or nose screws are loose. 4. Driver or driver guide are worn or damaged.	1. Use correct staples. 2. Use undamaged, clean staples. 3. Tighten magazine.  4. Replace worn or damaged parts.



# Parts

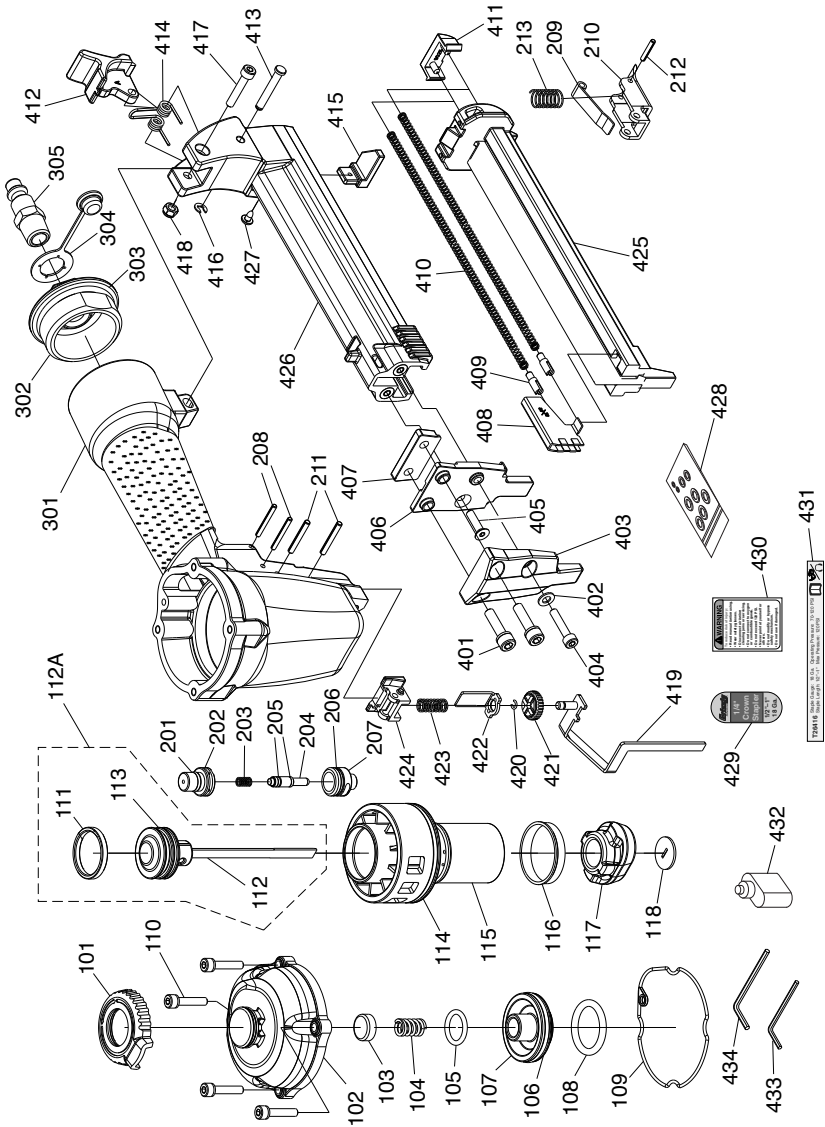

**Please Note:** We do our best to stock replacement parts whenever possible, but we cannot guarantee that all parts shown here are available for purchase. Call (800) 523-477 or visit our online parts store at [www.grizzly.com](http://www.grizzly.com) to check for availability.

# Parts List

REF	PART #	DESCRIPTION
101	PT26416101	DEFLECTOR
102	PT26416102	CYLINDER CAP
103	PT26416103	CYLINDER CAP REAR SEAL
104	PT26416104	COMPRESSION SPRING
105	PT26416105	O-RING 13.8 X 2.4 P14
106	PT26416106	O-RING 31.8 X 2.4
107	PT26416107	PISTON VALVE
108	PT26416108	O-RING 22.1 X 3.5 P22.4
109	PT26416109	CYLINDER CAP FRONT SEAL
110	PT26416110	CAP SCREW M4-.7 X 20
111	PT26416111	PISTON RING
112A	PT26416112A	PISTON ASSEMBLY
112	PT26416112	PISTON W/DRIVER
113	PT26416113	O-RING 21 X 2
114	PT26416114	O-RING 46.76 X 2.5
115	PT26416115	CYLINDER
116	PT26416116	CYLINDER RING
117	PT26416117	BUMPER
118	PT26416118	DRIVER GUIDE
201	PT26416201	O-RING 7.5 X 1.5 S8
202	PT26416202	TRIGGER VALVE HEAD
203	PT26416203	COMPRESSION SPRING
204	PT26416204	PLUNGER
205	PT26416205	O-RING 2.5 X 1.5 S3
206	PT26416206	O-RING 11 X 1.6
207	PT26416207	PLUNGER CAP
208	PT26416208	ROLL PIN 3 X 22
209	PT26416209	SECONDARY TRIGGER
210	PT26416210	TRIGGER
211	PT26416211	ROLL PIN 2.5 X 22
212	PT26416212	ROLL PIN 2.5 X 14
213	PT26416213	COMPRESSION SPRING
301	PT26416301	GUN BODY
302	PT26416302	BODY END CAP
303	PT26416303	O-RING 37 X 3
304	PT26416304	VALVE CAP

REF	PART #	DESCRIPTION
305	PT26416305	QUICK-DISCONNECT VALVE
401	PT26416401	CAP SCREW M5-.8 X 20
402	PT26416402	FLAT WASHER 8MM
403	PT26416403	RELIEF PLATE
404	PT26416404	CAP SCREW M4-.7 X 18
405	PT26416405	FLAT HD CAP SCR M4-.7 X 16
406	PT26416406	DRIVER GUIDE COVER
407	PT26416407	GASKET
408	PT26416408	PUSHER
409	PT26416409	SPRING SHAFT
410	PT26416410	PUSHER COMPRESSION SPRING
411	PT26416411	REAR PLATE
412	PT26416412	QUICK-RELEASE LATCH
413	PT26416413	CAPTIVE PIN
414	PT26416414	TORSION SPRING
415	PT26416415	STOPPER
416	PT26416416	E-CLIP ETW-3
417	PT26416417	CAP SCREW M4-.7 X 25
418	PT26416418	LOCK NUT M4-.7
419	PT26416419	SAFETY PROBE
420	PT26416420	WHEEL CLIP
421	PT26416421	DEPTH ADJUSTMENT WHEEL
422	PT26416422	SAFETY SLIDE BRACKET
423	PT26416423	SAFETY COMPRESSION SPRING
424	PT26416424	SAFETY GUIDE
425	PT26416425	MAGAZINE BOTTOM
426	PT26416426	MAGAZINE TOP
427	PT26416427	TAP SCREW M3 X 6
428	PT26416428	O-RING REPLACEMENT KIT
429	PT26416429	ID LABEL
430	PT26416430	WARNING LABEL
431	PT26416431	SPECIFICATIONS LABEL
432	PT26416432	BOTTLE FOR OIL
433	PT26416433	HEX WRENCH 3MM
434	PT26416434	HEX WRENCH 4MM

# WARRANTY

---

---

Grizzly Industrial, Inc. warrants every product it sells for a period of **1 year** to the original purchaser from the date of purchase. This warranty does not apply to defects due directly or indirectly to misuse, abuse, negligence, accidents, repairs or alterations or lack of maintenance. This is Grizzly's sole written warranty and any and all warranties that may be implied by law, including any merchantability or fitness, for any particular purpose, are hereby limited to the duration of this written warranty. We do not warrant or represent that the merchandise complies with the provisions of any law or acts unless the manufacturer so warrants. In no event shall Grizzly's liability under this warranty exceed the purchase price paid for the product and any legal actions brought against Grizzly shall be tried in the State of Washington, County of Whatcom.

We shall in no event be liable for death, injuries to persons or property or for incidental, contingent, special, or consequential damages arising from the use of our products.

To take advantage of this warranty, contact us by mail or phone and give us all the details. We will then issue you a "Return Number," which must be clearly posted on the outside as well as the inside of the carton. We will not accept any item back without this number. Proof of purchase must accompany the merchandise.

The manufacturers reserve the right to change specifications at any time because they constantly strive to achieve better quality equipment. We make every effort to ensure that our products meet high quality and durability standards and we hope you never need to use this warranty.

Please feel free to write or call us if you have any questions about the machine or the manual.

Thank you again for your business and continued support. We hope to serve you again soon.

**grizzly.com**<sup>®</sup>  
**TOOL WEBSITE**

Buy Direct and Save with Grizzly<sup>®</sup> – Trusted, Proven and a Great Value!  
~Since 1983~

*Visit Our Website Today For  
Current Specials!*

**ORDER  
24 HOURS A DAY!  
1-800-523-4777**



## Free Manuals Download Website

<http://myh66.com>

<http://usermanuals.us>

<http://www.somanuals.com>

<http://www.4manuals.cc>

<http://www.manual-lib.com>

<http://www.404manual.com>

<http://www.luxmanual.com>

<http://aubethermostatmanual.com>

Golf course search by state

<http://golfingnear.com>

Email search by domain

<http://emailbydomain.com>

Auto manuals search

<http://auto.somanuals.com>

TV manuals search

<http://tv.somanuals.com>