

THE hafler PREAMPLIFIER

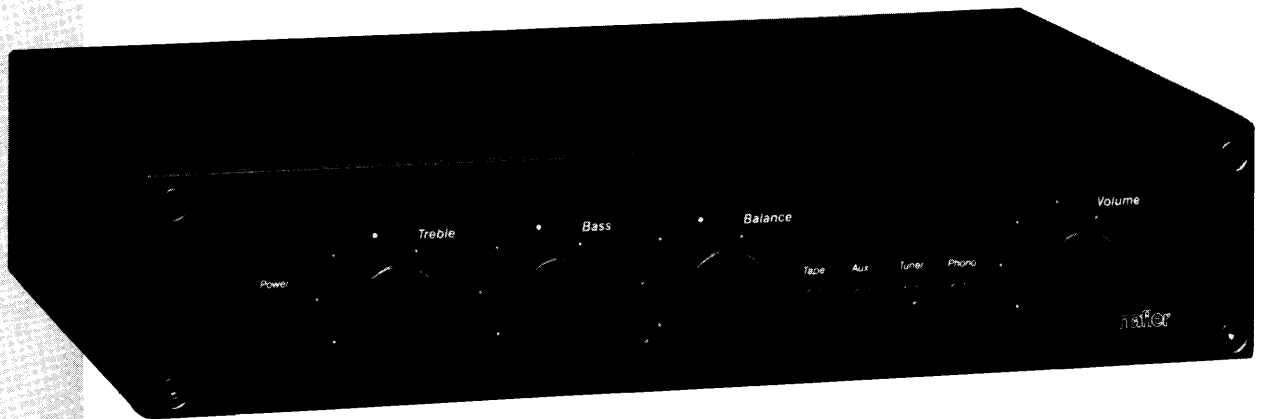

Series 2 DH-100 PREAMPLIFIER OWNERS MANUAL

LM163

THE DAVID HAFLER COMPANY
Division of Rockford Corp.

5910 Crescent Boulevard, Pennsauken, New Jersey 08109

613 South Rockford Drive • Tempe, AZ 85281

Please refer to this serial
number in all communications
regarding this equipment.

A 3833601

SPECIFICATIONS

(Specifications stated with load of 27K ohms in parallel with 1.5 nanofarads, and for the band between 20Hz and 20KHz unless noted.)

PHONO PREAMP SECTION:

Rated Output: 3 Vrms
Maximum Output: 8 Vrms
Harmonic Distortion: Less than 0.005%
RIAA Frequency Response: ± 0.25 dB, 20-20 KHz
 ± 0.1 dB, 40-20 KHz
Sensitivity: 10 mV for $\frac{1}{2}$ volt @ Record Out
Maximum Input: 180 mV @ 1 KHz
Gain: 34 dB @ 1 KHz
Input Impedance: 47.5 K ohms in parallel with 130 pF.
Signal/Noise Ratio: greater than 100 dB, 'A' weighted.

LINE AMPLIFIER SECTION:

Rated Output: 3 Vrms
Maximum Output: 8 Vrms
Harmonic Distortion: less than 0.005%
Frequency Response: ± 0.25 dB, 20-20 KHz
Gain: 20 dB
Input Impedance: greater than 35 K ohms
Signal/Noise Ratio: greater than 100 dB, 'A' weighted

Crosstalk: down 80 dB
Separation: greater than 70 dB @ 1 KHz,
 55 dB @ 10 KHz
Bass Control: ± 10 dB @ 20 Hz, moving inflection type
Treble Control: ± 10 dB @ 20 KHz, shelving type

GENERAL SPECIFICATIONS:

Semiconductors: 7 integrated circuits, 5 diodes, 1 LED
Inputs: Phono, Tuner, Aux, Tape
Outputs: Record, Line
Controls: Volume, Balance, Treble, Bass, Input select by push button, Tape Monitor, Power
AC Supply Voltage: 95-130 or 190-260 VAC, 50-60 Hz.
Power Consumption: less than 5 watts
AC Convenience Outlets: 2 switched
Size: 13-9/16 \times 3 \times 10 inches
Shipping Weight: 9 lbs.
Net Weight: 7 lbs.

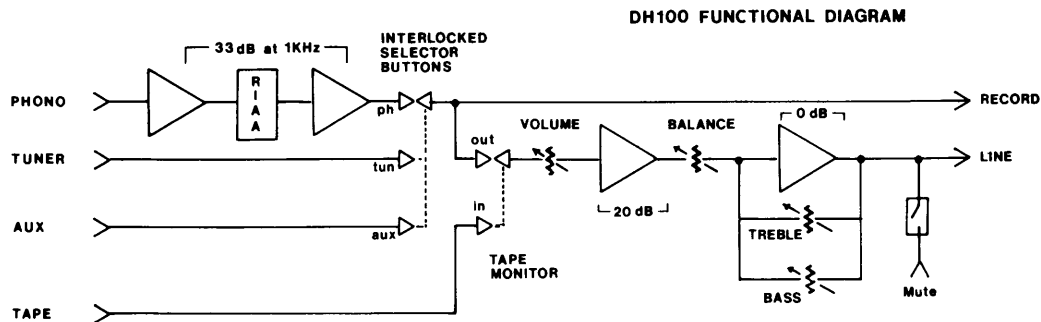

WARNING: To prevent fire or shock hazard, do not expose this equipment to rain or moisture.

© Copyright 1988. All rights reserved.

CONTENTS

Specifications	2	Additional Parts List	5
Functional Diagram	2	Operation	6
Installation	3	Notes on the Circuitry	6
Component List	4	Additional Information	7
Parts Placement Diagram	4	Warranty and Service Policy	8
Schematic Diagram	5		

INTRODUCTION

The DH100 Preamplifier must surely represent the highest quality per dollar of any audio product manufactured in this decade. Initial response to the performance of this unit, during development and testing, has been unusually enthusiastic. The quality arises from the meticulous application of good engineering practice — respect for the fragility of the audio signal; simple, straightforward circuitry; careful component selection and testing; generous circuit card topology, and use of precision tolerances where they contribute significantly to performance.

The design philosophy of the DH100 exemplifies simplicity

and economy. To achieve this we have provided only those functions that are primary to a good audio system, and we have been most careful to see that the integrity of the electronics conforms to a high standard.

Although it might be thought that a low-cost preamplifier would not find its place among higher-priced components, the DH100 may change such thinking, for its ability to preserve the detail rendered by expensive cartridges, power amplifiers and loudspeakers is most impressive. We invite you to compare its performance with the highest-rated preamplifiers, and to tell us of your findings.

INSTALLATION

1.0 MOUNTING

The DH100 Preamplifier is intended for table top or shelf mounting. No rack mount provision is made. It is important that the Preamplifier not be placed directly on top of power amplifiers or other high-current devices; otherwise hum fields may be intercepted by the Preamplifier and heard in the loudspeakers. It is not necessary to provide much ventilation to the DH100, however it is a good rule to allow air circulation around any electrical device.

2.0 POWER CONNECTIONS

Preamplifiers are supplied with transformers for standard United States line voltage. Wide variations are tolerated, between 100 volts and 130 volts. For overseas use, an International transformer is available which accommodates line voltages between 200 and 260 volts (Hafler Part Number TA127). It is recommended that the Preamplifier be connected directly to a wall or floor outlet, and not to an extension cord, particularly if the Preamplifier is being used to switch a power amplifier.

2.1 ACCESSORY OUTLETS

Two outlets are provided, both controlled by the Preamplifier POWER switch, and adequate to operate a DH-120, XL-280 or DH-500 power amplifier and a tuner or tape transport. In some countries the AC convenience outlets are not provided.

3.0 OUTPUT CONNECTIONS

Output jacks are labeled 'L' for left channel and 'R' for right channel.

3.1 LINE OUTPUT

These jacks connect to the power amplifier input jacks of your system. The signals at the Line Outputs are affected by the BALANCE, VOLUME, BASS, and TREBLE Controls and the MUTING circuit. Note that the DH100 is not meant to drive audio cables longer than six feet.

3.2 RECORD OUTPUT CONNECTIONS

These are signal outputs to a tape recorder, for making recordings from PHONO, TUNER, and AUX inputs. You will use a 'line' input on your tape recorder (not a microphone input!) and adjust the tape input level controls for a good meter reading. Note that a tape recorder or other signal source connected to the TAPE input of the DH100 may not be recorded. The MUTING circuitry does not protect the RECORD outputs.

4.0 LINE INPUTS

A LINE LEVEL input is a general purpose input (as opposed to an equalized input, like PHONO) which expects a standard nominal voltage for proper operation. Most equipment for use with a preamplifier — tuners, tape decks, etc. — have an output that more or less conforms to this standard voltage.

All the line level inputs, TUNER, AUX (Auxiliary), and TAPE, in the DH100 have the same signal capability and may be used for other than their labelled purpose. For instance, a tape recorder or video sound source may be connected to any of these inputs. The 'sound' output from most home computers may be connected to these inputs as well (see ADDITIONAL INFORMATION.)

You must observe Left and Right Channel symmetry (ie: connect Left to Left and Right to Right) between the DH100 and any signal source connected to it.

The PHONO, TUNER, and AUX switches are self-cancelling; that is, the last button pushed releases the previous button. Note, however, that the TAPE switch is **not** part of this self-cancelling group and that it supersedes any other input you may have selected. Be certain to check the position of this switch if your preamplifier sometimes seems inoperative.

While the nominal signal level for a line input is 50 millivolts, higher level signals may be accommodated because they pass through the VOLUME control before being amplified. The input impedance is approximately 35000 ohms. When a tape recorder is connected to the RECORD outputs, this impedance will drop slightly.

Input jacks are labelled 'L' (for Left) and 'R' (for Right) Channel signals.

5.0 PHONO INPUT

The PHONO input is meant to accommodate standard moving magnet cartridges with signal outputs in the 5 millivolt range. Some 'high output' moving coil cartridges will operate satisfactorily with the DH100 as well, although VOLUME settings will be in the upper third of the range of that control. Normally, use of a moving coil cartridge will require a pre-preamplifier ('head amp') or step-up transformer. (Your dealer will be glad to tell you about suitable products for this purpose.) A grounding lug is provided on the back panel, under the Right PHONO input, normally used to connect the ground wire from the turntable to the Preamplifier chassis. (Sometimes the user encounters unpredicted behavior in the turntable-preamplifier connection. In case of difficulty, see the section on PHONO installation, ADDITIONAL INFORMATION, later in this Manual.)

5.1 CARTRIDGE LOADING

The input impedance is 47,500 ohms in parallel with 130 picofarads. This resistance value is standard for most cartridges. The capacitance (130 pf) when added to customary cable capacitances in the leads between turntable and preamplifier, will bring the total capacitance value within the range recommended by most cartridge manufacturers. (To 'customize' these input specifications, see ADDITIONAL INFORMATION.) The PHONO input is 'guarded' by a 1 microfarad blocking capacitor (C1) to protect both the Preamplifier and the cartridge. THE DAVID HAFLE COMPANY will not assume responsibility for equipment damage, of any kind, if this capacitor is removed or defeated. (See ADDITIONAL INFORMATION.)

(The following resistors are metal film, 1/4W, 1% unless noted.)

Part No.	Jack, RCA phono type, single circuit
XP015	
Q1-131	J112 muting FET
Q1,101	
R1,101	47.5 K ohms
R2,102	12.1 K ohms
R3,103	316 ohms
R4,104	28.0 K ohms
R5,105	3.92 K ohms
R6,106	12.1 K ohms
R7,107	1.10 K ohms
R8-R11	1 megohm
R108-	
R111	1 megohm
R12,112	150 ohms
R13,113	Potentiometer, VOLUME, 2 X 50K audio taper
R14,114	274 K ohms
R15,115	10.0 K ohms
R16,116	1.10 K ohms
R17,117	Potentiometer, BALANCE, 2 X 50K linear taper
R18,118	22.1 K ohms
R19,119	4.75 K ohms
R20,120	1.10 K ohms
R21,121	1.10 K ohms
R22,122	4.75 K ohms
R23,123	Potentiometer, TREBLE, 2 X 25K, special taper
R24,124	Potentiometer, BASS, 2 X 25K, special taper
R25,125	22.1 K ohms
R26,126	150 ohms
R27,127	1000 ohms, carbon film, 5%
R28,29	470 K ohms, carbon film, 5%
R30	10 K ohms, carbon film, 5%
R31	39 K ohms, carbon film, 5%
R32	2.2 megohms, carbon film, 5%
R33	270 ohms, carbon film, 5%
R34,35	100 K ohms, carbon film, 5%
R36	4.7 K ohms, carbon film, 5%
R37	1.8 K ohms, carbon film, 5%
R38	390 K ohms, carbon film, 5%
R39	2.7 K ohms, carbon film, 1/2 Watt, 5%
S1-S4	Switch, Selector assembly, Non-shorting
S5	Switch, POWER, Push-push type, SPST
T1	Transformer, 120VAC Primary alternate 220VAC Primary

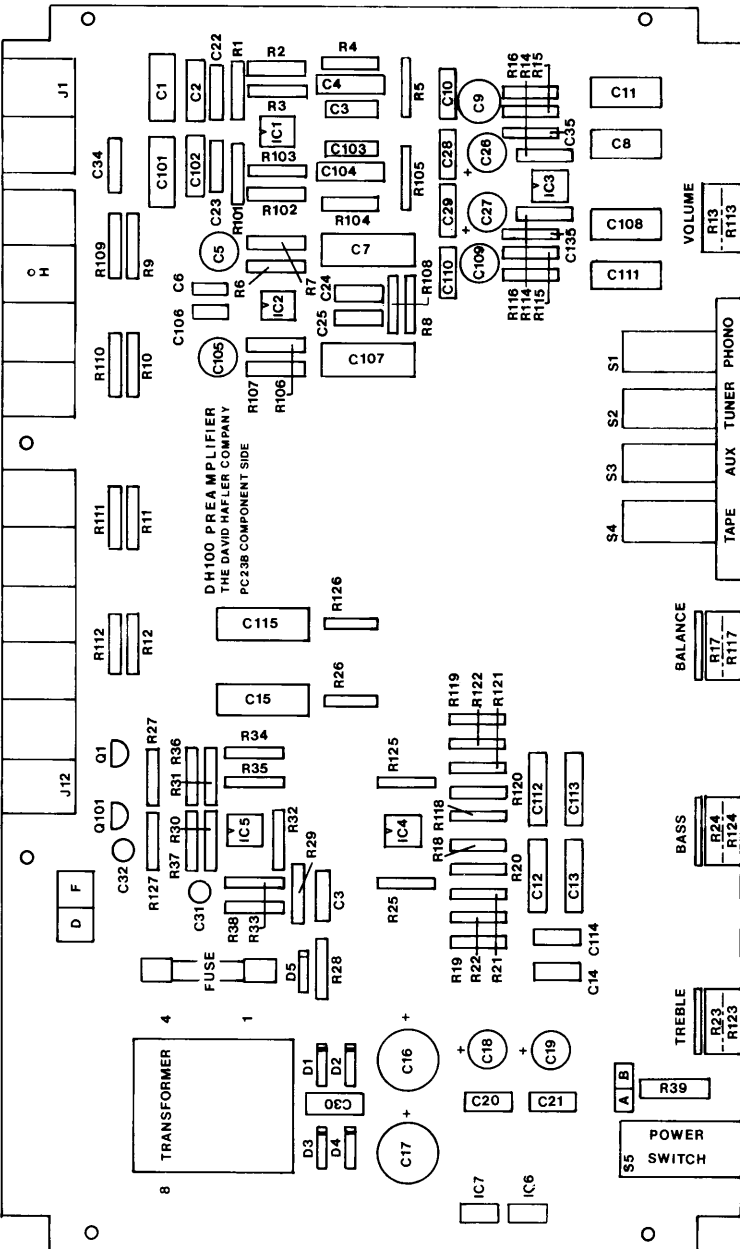

DH100 COMPONENT LIST

Part No.	Component Description
CC126	Capacitor, polycarbonate. 1.0 MFD/100V
CP112	Capacitor, polypropylene. 120 pFD/160V
CP138	Capacitor, polypropylene. 0.033 MFD/160V
CL111	Capacitor, electrolytic. 470 MFD/25V
CP138	Capacitor, polypropylene. 0.033 MFD/160V
CZ113	Capacitor, ceramic disk. 0.005 MFD/1000V
CN118	Capacitor, electrolytic, NP. 4.7 MFD/25V
CP138	Capacitor, polypropylene. 0.033 MFD/160V
CP115	Capacitor, polypropylene. 2.2 MFD/100V
CC126	Capacitor, polycarbonate. 1.0 MFD/100V
CN112	Capacitor, electrolytic, NP. 220 MFD/10V
CP138	Capacitor, polypropylene. 0.033 MFD/160V
CC126	Capacitor, polycarbonate. 1.0 MFD/100V
CP143	Capacitor, polypropylene. 0.1 MFD/1%/160V
CP143	Capacitor, polypropylene. 0.1 MFD/1%/160V
CP139	Capacitor, polypropylene. 0.01 MFD/1%/160V
CP115	Capacitor, polypropylene. 2.2 MFD/100V
CL124	Capacitor, electrolytic. 1000 MFD/50V
CL111	Capacitor, electrolytic. 470 MFD/25V
CP138	Capacitor, polypropylene. 0.033 MFD/160V
C22,23	Capacitor, polypropylene. 0.033 MFD/160V
C24,25	Capacitor, polypropylene. 0.033 MFD/160V
C26,27	Capacitor, electrolytic. 470 MFD/25V
C28,29	Capacitor, polypropylene. 0.033 MFD/160V
C30	Capacitor, ceramic disk. 0.005 MFD/1000V
C31,32	Capacitor, electrolytic, NP. 4.7 MFD/25V
C33	Capacitor, polypropylene. 0.033 MFD/160V
C34	Capacitor, ceramic disk. 0.005 MFD/1000V
C35,135	Capacitor, polypropylene. 47 pFD
D1-D5	Diode, 1N4003
D6	LED, red, nipple tip
F1	Fuse, 1/16 A. (slo-blo)
IC1-IC4	Operational Amplifier, MC33078/5532
IC5	Dual Comparator, LM393
IC6	Regulator, negative, 7915
IC7	Regulator, positive, 7815
QB161	Operational Amplifier, MC33078/5532
QB116	Dual Comparator, LM393
QB147	Regulator, negative, 7915
QB146	Regulator, positive, 7815

DH100 MISCELLANEOUS PARTS

Part No.	Description	Part No.	Description	Part No.	Description
MS174	Clip, fuse	HR156	Angle bracket	HR156	Terminal strip, 2 lug
MS179	Back panel	HZ138	Allen wrench, L-shape, end caps	HZ138	Insulator for IC6 & IC7, greaseless
MS173	Bottom plate	HZ139	Allen wrench, L-shape, knobs	HR135	Shrinkable tubing, 1/2"
ME118	Front panel, extrusion	HR134	Rubber feet, adhesive back	HK122	Knurled thumb-nut, 4-40
MC111	End cap, front panel	HR127	Plastic grommet, U-shape, linear	HR164	Nut, 4-40, nylon
HD117	Knob, metal	HR129	Rubber grommet, 3/8"	HK115	Nut, M7 X .75, control
HD121	Push button, black	HR144	Strain relief, line cord	HP122	Set screw, 8-32 Allen, knobs
MS169	Front sub-panel	WA043	Line cord with plug	HP114	Cap screw, 10-32 Allen, end caps
MS171	Side piece	XA021	AC outlet	HR162	Screw, 4-40 x 1-3/8", nylon
HZ127	Clip, fuse	XT012	Socket, IC, 8 pin DIP	HR156	Washer, shoulder, for TO220

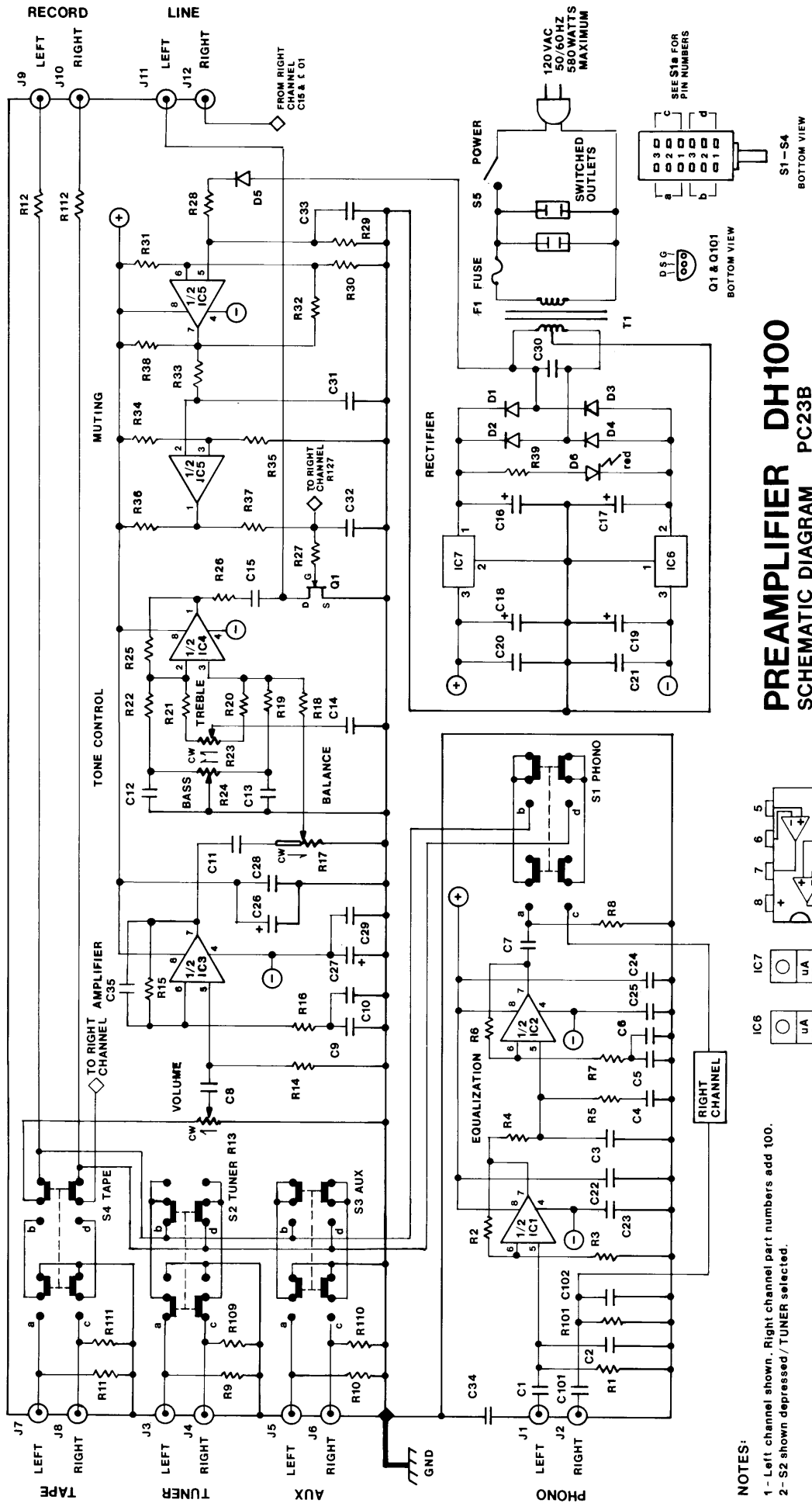

NOTES:

- 1 - Left channel shown. Right channel part numbers add 100.
- 2 - S2 shown depressed/TUNER selected.

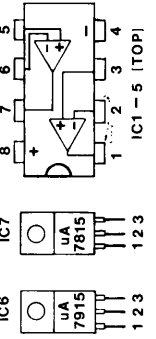

PREAMPLIFIER DH100 SCHEMATIC DIAGRAM PC23B SERIES 2

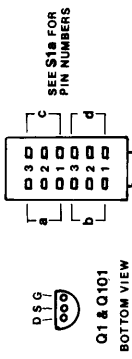

OPERATION

6.0 POWER CIRCUITRY

When the DH100 is turned ON, the red LED will illuminate at the left center of the panel. At the same time, an internal muting circuit will limit the signal passing from the Preamplifier to your power amplifier for about 1.5 seconds, until the Preamplifier circuits have stabilized. During this 1.5 seconds you may hear the tuner or phonograph or other selected signal at greatly reduced level. When the DH100 is turned OFF, the muting circuit engages to protect the power amplifier against turn-off transients. If you turn OFF the Preamplifier and turn it ON again immediately, the muting circuit will still allow only reduced output for 1.5 seconds. During muting time, what signal you hear may sound distorted. Such distortion is normal and does not indicate a Preamplifier problem; it will disappear when muting is completed.

6.1 SIGNAL SELECTION PUSHBUTTONS

The function of these controls has been discussed in Section 4.0. The Line level inputs, TUNER, AUX, and TAPE, all have the same input circuitry. When any switch is NOT selected, its input is left 'floating' (not grounded, as in most preamplifiers) but an isolating ground is imposed between the incoming signal and the Preamplifier to eliminate inter-source feedthrough. The reason for providing this kind of input is to accommodate signal sources that will not tolerate a short circuit to ground at any time, such as some tape recorder and computer outputs.

6.2 VOLUME CONTROL

This control has a smooth continuous rotation. The 'unity gain' position (where Line input and output voltages are the same) is at about the 11 o'clock setting of the VOLUME control.

6.3 TONE CONTROLS

The tone circuit in the DH100 is unusual in three respects; it is not switched IN or OUT, it has an amplifier dedicated to tone operations only, and it uses a unique balanced circuit to obtain boost and cut.

The reason many preamplifiers provide tone switching is that tone circuits tend to interfere with the bandwidth, or overall frequency response, of the preamplifier. This is not the case in the DH100. Neither response nor distortion are deteriorated by the tone circuitry, and when the controls are in their center (detented) position, response is flat within 0.1 dB.

A 'balanced' circuit is obtained by using an operational amplifier in a differential configuration. This type of control permits a simple, economical parts symmetry, with adequate feedback for low distortion. Precision tolerances are used in this circuit to provide a flat response at detent position and to provide similar characteristics from unit to unit. The controls are tapered so that small changes will occur in the area of the detent, with boost or cut becoming more evident as the control is moved away from center. As a general rule, extreme settings of the tone controls indicate a frequency response limitation in some part of the system, usually the signal source or the loudspeaker. When high settings are used, it is most likely you are listening to large amounts of hiss and rumble, and not too much music. The minimum amount of boost and cut necessary for enjoyment is the best.

6.4 BALANCE CONTROL

The BALANCE control adjusts the relative amount of Left and Right loudspeaker volume. We find that customers have a hesitation in using this control, and it should not be so. The purpose of balancing the sound is to make the image of the music seem centered in your listening area. The placement of the speakers and furnishings in the room, your listening position in

the room — all affect the position of the stereo image. It is legitimate to use the BALANCE control to make this image comfortable for you. Not all phonograph recordings and broadcasts are balanced at their source, so you may want to correct for this with the BALANCE control. Usually, experiment will dictate a normal setting in your room.

When the control is fully clockwise only the Right Channel information will be heard, from the right loudspeaker. If it's coming from the left, check the connection of your cables. Something is reversed. A fully counter-clockwise setting produces only Left Channel information, from the left loudspeaker. The center detent provides equal level to both loudspeakers with an accuracy of 0.1 dB.

Careful interconnection is the best way to insure that Left information will be on the left and Right information on the right. An additional check can be made if you own recordings of a symphony orchestra, for virtually every orchestra of this type places violins on the left and cellos on the right of the stage. Careful listening will confirm this location for these instruments if Left and Right signals are correct.

NOTES ON THE CIRCUITRY

7.0 PHONO STAGES

Two operational amplifiers make up the phono section of the DH100. The RIAA equalization is **passive** in this preamplifier, which means that feedback is not used to determine the necessary response curve for playing phonograph records. All the passive components in the PHONO circuit carry 1% tolerances. The use of passive circuitry offers considerable design freedom when using integrated circuits, and permits these 'chips' to function adequately in a quality preamplifier by not asking a single chip to "do too much." Two stages also provide exceptional input-output isolation and a slightly better input overload characteristic. The gains of the two stages have been selected to provide, in our opinion, the most practical division for gain, noise, and overload specifications. DC coupling has been preserved to eliminate both the cost and compromise of yet another coupling capacitor. Special care has been taken to insure close tolerances to the RIAA characteristic in the critical mid-band region.

7.1 POWER SUPPLY

We are mindful of the beneficial influence of a clean power supply, with good dynamic regulation and the accompanying low impedance at all audio frequencies. The dual-tracking regulator in the DH100 tolerates a wide range of line voltage variations. To maintain a low impedance at high frequencies we have employed low ESR electrolytic capacitors and bypassed the power carrying traces at frequent intervals with polypropylene capacitors. The ground traces have been drawn at five times their required size, to ensure very low ground path impedances.

7.2 SWITCHING

A deliberate effort was made to keep the number of switch contacts in the signal path to a minimum; this meant, eventually, only two switches for each signal to pass through, except the TAPE input, which manages with only one.

7.3 CAPACITOR SELECTION

Capacitors with polypropylene and polycarbonate dielectrics have been used wherever possible to take advantage of their low distortion. Such use is very rare in economical audio components and contributes significantly to the sonic qualities of the DH100.

ADDITIONAL INFORMATION

8.0 The following paragraphs discuss some of the answers to frequently-asked questions regarding connection of peripherals to the DH100 amplifier. If you have a problem, read this section carefully before contacting the Factory.

8.1 PHONO INPUT CAPACITOR

Coupling Capacitors, C1 (Left) and C101 (Right), are placed at the input to the Phono stage to provide DC isolation between the cartridge and the input amplifier. The value is 1.0 mfd. When this capacitor is jumpered, thus removing it from the circuit, several problems may arise. Some turntables 'short' the cartridge leads to ground when the tone arm is in the rest position. With the capacitor removed, this grounding may upset the 'balance' of the Phono amplifier and produce a dangerous transient to the power amplifier, enough to damage a loudspeaker. Other times, this grounding may produce an unpleasant hum. There is a small and usually harmless direct current flowing from the input stage through your cartridge without this capacitor, but unless you have engineering knowledge of the parameters involved, you cannot rely on the safe value of this current. PLEASE NOTE THAT THIS MODIFICATION (eliminating these capacitors) MAY INVALIDATE YOUR WARRANTY.

8.2 PHONO GROUNDING

Nearly all turntables have three cables connecting them to the preamplifier; one each for Left and Right Channels, and a third single wire for grounding. The single wire is meant to be secured under the thumb screw below the Right PHONO input jack. A bad connection at this point will surely be a source of hum and must be corrected.

Hum will also be heard if the Left and Right Channel plugs are not firmly seated on the PHONO jacks.

After checking all the conditions stated above, if your system hums on PHONO but not on any Line input, turn OFF the Preamplifier and reverse the line plug to your turntable. Often this will cure the problem.

As a rule, it does not help hum, anywhere in the system, to ground the Preamplifier to an 'earth' ground, such as a water pipe. Good grounds like this are hard to find, and such a connection often makes the situation worse, particularly in the case where there is Radio Frequency Interference (RFI).

8.3 PHONO INPUT PARAMETERS

The value of PHONO input resistance (R1, R101) may be changed if necessary. If the value is decreased (less than 47.5 K) then C1-C101 will have to be increased to preserve the frequency response. If R1-R101 are increased, the input capacitors will not have to be changed, and the low frequency response will improve slightly. See the Parts Placement Diagram for the position of these resistors.

The input loading capacitors, C2, C102 may also be changed if necessary. The total load capacitance on a cartridge is the algebraic sum of three separate capacitances; a) the capacitance of the cable between the turntable and the Preamplifier, b) the value of C2 or C102, and the input capacitance of the DH100 phono stage without C2.

a) Typical cable value is 150 pf.	a) 150
b) Present value is 120 picofarads.	+ b) 120
c) Input value without C2 is 10 pf.	+ c) 10
Total capacitance = 280 pf.	

Required values for proper cartridge loading can lie between 100 and 470 picofarads. While it is desirable to have the value close to the manufacturer's recommendation, this value is not critical.

When replacing these components, use a good polypropylene capacitor for C1 and C2, and a metal film resistor for R1.

8.4 MONO OPERATION

A preamplifier in MONO mode usually combines the Left and Right Channel information and delivers this summed signal to both outputs. Its use is limited to older phonograph recordings and to a few inputs which are available in MONO only, such as a monaural tape deck, video sound signal, and computer sound outputs.

There are two options open to the user if a MONO source is to be used. The easiest option is to connect the signal to the Left input jack and listen to the source with the BALANCE control fully counterclockwise. Or the BALANCE control may be set at center and a grounding plug inserted in the Right input jack. In either case, only the Left loudspeaker will be active. If one mono signal is applied to AUX left, and one to AUX right jacks, then the BALANCE control will select one, the other, or a mixture of the two — two inputs for one.

A more satisfactory input configuration is through the use of a 'Y' interface cable. This device accepts a mono input plug and branches out to two plugs, one each for the Left and Right Preamplifier jacks on a Line input. The advantage is that both loudspeakers will reproduce the mono signal source. In this case, only one device may be connected per Line input.

Home computers with sound output may be connected to the DH100. Such outputs vary widely from one computer to another, so you will have to consult a dealer or the computer schematic diagram to see what the signal parameters are. We have eliminated one potential problem for you by seeing to it that the input signal is never grounded when not in use. Keep in mind that the computer output level may be much higher than typical for audio components. In this case a resistive voltage divider may be used to reduce the signal level. FIG 8.4 shows a typical connection. Ry should be kept at 10000 ohms, and Rx varied for a good signal level. It would be possible to adjust Rx so that computer level is the same as the TUNER or PHONO at similar VOLUME control settings. FIG 8.4 also shows Rx and Ry combined in a level control potentiometer which must be mounted exterior to the Preamplifier, perhaps in a junction box of some kind.

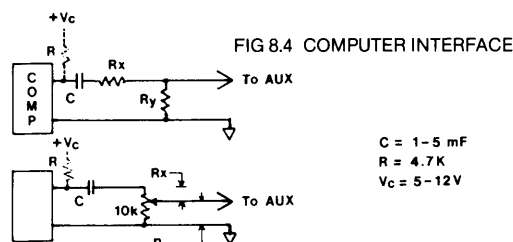

8.5 HEADPHONE CONNECTION

The DH100 has no output jack for headphones. The Line outputs will, however, drive high impedance headphones (200 to 2000 ohms) to a level satisfactory for normal listening. It is assumed that if you use the DH100 for headphone listening, you are not also using it with a power amplifier. The DH100 controls make it a very good preamplifier for headphone use. There are conversion 'boxes' available from your dealer for connecting headphones to the power amplifier and these will prove to be a satisfactory way to use both loudspeakers and headphones on the same system, including standard low impedance phones (4 ohms).

8.6 PREAMPLIFIER OUTPUT CAPACITOR

In this day of higher and higher audio power, protection circuitry is a most important feature of HAFLEP equipment. The protection circuitry in our preamplifiers and power amplifiers is meant for the benefit of both these units and your valuable loudspeakers. For this reason you should **never** defeat the coupling capacitors in a HAFLEP preamplifier or power amplifier. The DH100 Muting circuitry requires the coupling capacitor to prevent DC output to the power amplifier. REMOVAL OF THIS CAPACITOR MAY INVALIDATE YOUR WARRANTY.

SERVICE POLICY AND LIMITED WARRANTY

The DH100 Preamplifier has been carefully designed to provide many years of use without maintenance or service. Factory assembled units undergo rigorous testing before they are shipped. However, damage in transit and human error can intervene to make service necessary.

It is the owner's responsibility to return the unit, freight prepaid and insured, to the factory, or to the nearest factory authorized service facility. Units shipped freight collect will not be accepted. Shipment should be made by United Parcel Service (UPS) wherever possible. We will not be responsible for damage incurred in shipments by Parcel Post; repairs, in this case, will be made solely at the owner's expense. All shipments should be insured for the full value of the unit.

Use the original carton and packing material, and enclose all of the following:

- a) Complete shipping address (PO Box numbers are **not** acceptable),
- b) Serial number (if not on unit)
- c) Copy of dated Bill of Sale, for Warranty service.
- d) Description of malfunction. If it is intermittent, indicate this!

Warranty service is guaranteed for 90 days. Warranties apply to the original purchaser only and are void if the Preamplifier has been modified without factory consent, or if parts have been substituted which the factory considers unsuitable, or if the Preamplifier has been physically or electrically abused or used for some purpose for which it was neither designed nor intended.

WARRANTY FOR FACTORY-ASSEMBLED UNITS:

A factory assembled DH100 is warranted for 3 full years from purchase date, including parts, labor and normal return shipping costs to the owner within the continental United States. The owner is responsible for shipment to the factory or authorized service facility, and must submit a copy of the dated bill of sale when warranty service is requested.

WARRANTY FOR KIT-BUILT UNITS:

The parts supplied in a DH100 kit are warranted for one full year from the purchase date. If a defective component is found on a circuit board or in the kit, simply return the individual part to the factory prepaid, together with the serial number and the date of purchase. It will be replaced at no charge.

If you cannot locate the cause of a problem in your DH-100K, return it to the factory (with a copy of the dated bill of sale if in warranty) and a money order for \$35. Personal checks must first clear. VISA and Mastercharge can be processed by phone with your daytime phone number. If the difficulty is solely a defective part, the unit will be repaired and returned to you prepaid together with the amount of your payment **less a charge for packing and shipping**. If the problem is found to be an error in kit assembly, the unit will be put in proper working order and returned to you, prepaid within the continental USA.

This warranty is void if the kit has not been completely assembled, or if other than rosin core solder has been used. Units assembled with acid core or silver core, or paste flux, will be returned unserviced.

This warranty gives you certain rights. You may also have other rights, the extent of which may vary from state to state.

THE **david hafler** COMPANY

5910 CRESCENT BOULEVARD, PENNSAUKEN, NJ 08109 • 609/662-6355

Division of Rockford Corp. • 613 South Rockford Drive • Tempe, AZ 85281

THE HAFLER DH-100 PREAMPLIFIER KIT BUILDER'S MANUAL

LM164

ASSEMBLY INSTRUCTIONS

There are three basic rules for success in electronic kit building:

1. Read the instructions carefully, and follow them in order.
2. Make secure solder connections which are bright and smooth.
3. Check your work carefully after each step.

The DH-100 preamplifier is a versatile component with sophisticated circuitry which has been made remarkably easy to build by individuals with many years of experience in the design and engineering of the finest performing audio kits, and in the preparation of their manuals.

Kit building should be fun, and we are certain you will find this to be so. Fatigue increases the risk of error, so take a break rather than push to early completion. There are relatively few separate components in this design, to make it easy to pack everything away, if need be.

Your work area should have good lighting and the proper tools. The tools should include:

1. A 40 to 60 watt pencil soldering iron with a 3/16" or smaller tip which reaches 700°F.
2. 60/40 (60% tin) ROSIN CORE solder, 1/16" diameter or smaller.
3. A damp sponge or cloth to wipe the hot tip of the iron.
4. A wire stripping tool for removing insulation. This can be a *single-edge* razor blade, but inexpensive stripping tools are safer, faster and easier.
5. A medium-blade screwdriver (about 1/4" wide).
6. Needle-nose pliers (a long, narrow tip).
7. Diagonal or side-cutting small pliers.
8. Large "gas" or "slip-joint" pliers.
9. A 1/4" "Spin-tite" nut driver may be helpful, but is not necessary.

A soldering "gun" is *not* recommended. The unfamiliar user is more likely to damage the etched circuit boards with its higher heat potential and unbalanced weight. Also, because he may not wait long enough for it to reach operating temperature each time it is switched on, poor solder connections are more likely. Pencil irons are much lighter and easier to use, and there is no waiting time when solder connections follow in sequence, as in kit building. Make sure you have a holder for it, though, and always unplug it when you take a break.

Proper Soldering

There are four steps to make a good solder connection:

1. Make a good mechanical connection to hold the wire in position while heat and solder is applied.
2. Heat the *junction* of the wire and lug, or circuitry on the board, with the bright, shiny tip of the iron.
3. After heating for a couple of seconds, apply solder to the junction. It should melt immediately and flow smoothly around both surfaces.
4. Allow the connection to cool undisturbed.

Remember that the connection is made by the solder, not by mechanically attaching the wire to the terminal. Usually the wire is looped through the lug and crimped in place, but some prefer to just place it through the hole and rely on the stiffness of the wire to hold it while soldering. Connections to the circuit board, of course, are handled this way.

Good solder connections are *essential* for trouble-free, noise-free operation. A good solder joint does not require much solder around the conductors. Never "butter" partially melted solder on the joint, as it is useless. A good connection looks smooth and bright because the solder flows into every crevice when the parts are hot enough.

Continued on back page.

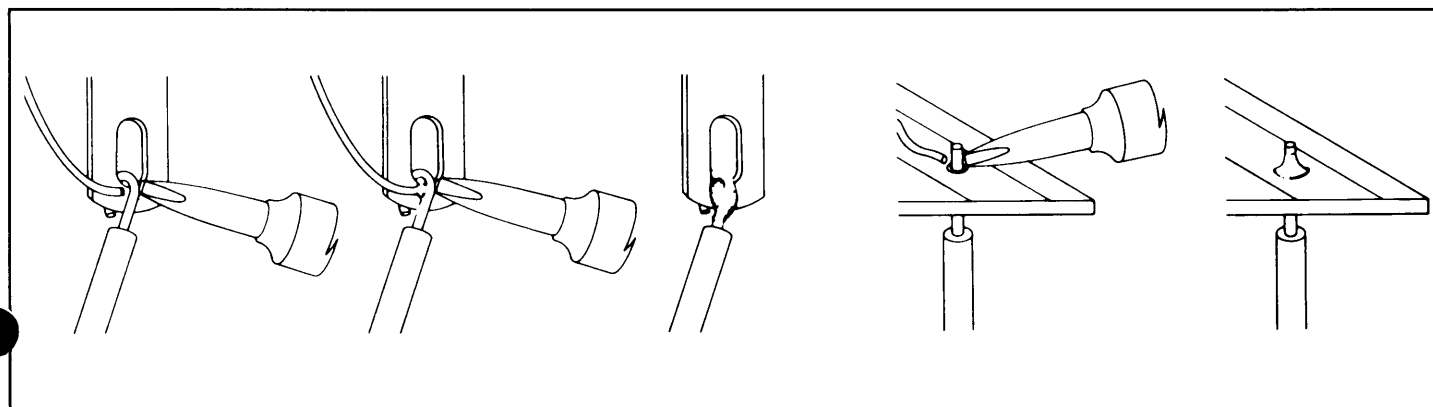

The iron must have a bright, shiny tip to transfer heat easily to the junction. That's why the damp sponge should be used frequently to wipe the tip, and occasionally you must add a small amount of solder to the tip, too. If a connection is difficult to heat, "wet" the tip with a small blob of solder to provide a bigger contact surface to the joint. Once the solder flows around the conductors, any movement must be avoided for a few seconds to allow a good bond. When cool, check the connection by wiggling the wire. If in doubt, or if the connection is not shiny, re-heat the joint. Excess solder may be removed from a connection by heating it and allowing the solder to flow onto the iron, which is then wiped on the sponge.

ALL SOLDER USED MUST BE ROSIN CORE

Never use acid core solder or any separate flux in electronic work. Silver solder is not suitable. If in doubt about unmarked solder, always obtain a fresh supply of rosin core solder. We recommend 60/40 for easiest use. Do not confuse it with 40/60, which is harder to melt.

The general procedure is to use a hot iron for a short time to heat a connection, then add solder with the iron still in contact. Remove the solder once it flows, and then remove the iron. A cooler iron applied for a longer time is more likely to damage components, or lift the copper circuit pattern from the board. A break in the etched circuit can be mended by simply soldering a small piece of wire across it. Do not allow much build-up of solder on the tip of the iron, or it may fall onto adjacent circuitry and cause a short circuit.

Assembly Tips

A 'set' of hardware includes a screw and a KEP nut (which has a lockwasher attached). Always install the lockwasher side first. Screws are always inserted from the outside of the chassis unless otherwise specified in the instructions. #4 hardware is smaller than #6, and in this kit, the #6 screws are finished in black, to match the cover.

To 'prepare' a wire means that you are to cut the designated length from that color supplied, and strip about 1/4" of insulation from each end. The wire supplied in the kit is #18 white, and #22 red and green, so you can set adjustable wire strippers accordingly. The line cord is #16. Be careful that you do not nick the wire when you strip it (that can happen more easily when you do not use wire strippers), for that weakens it. The wire supplied in the kit is 'bonded stranded,' which provides greater flexibility with resistance to breakage for easier use.

Whenever a connection is to be soldered, the instructions will so state, or will indicate by the symbol (S). If more than one wire is to be soldered at the same point, the indication will be (S-2) or (S-3). If soldering is not called for, other connections have yet to be made to that terminal. They would be more difficult if the connection was already soldered, but some builders prefer to solder each connection as they go. Every connection in the kit will be soldered when it is complete. Every lead which connects to a hole on the circuit board is to be soldered. After soldering a connection, clip off any excess lead length for neatness, and to minimize the possibility of a short circuit.

'Tinning' refers to the process of applying a light coating of solder to a bared wire end. On the line cord, for example, it keeps all the strands secured, and also makes a good connection easier. Simply touch the wire with the iron for a couple of seconds, and apply solder. Allow the excess to flow away onto the iron. When properly done, the wire is uniformly bright, and no larger than before. The hookup wire supplied with this kit does not normally need tinning, as it is pre-tinned.

It is a good idea to check off all the parts before you begin, to make sure that nothing has been overlooked, and to help you identify any unfamiliar items by comparing them with the list for each parts bag, and with the pictorial diagram. If a part is missing, a postcard, or a phone call to Customer Service at (609) 662-6084 will bring a prompt response.

KIT PARTS LIST

This list is in addition to the individual lists included in each of the parts bags, #1 through #4.

	Part No.		Part No.		
1	Circuit board assembly, PC-23	KF343	1	Fuse, spare, 1/16 amp slo-blo	SF019
1	Cover	MS174	2	End cap, front panel	MC111
1	Back panel	MS199	4	Knob, metal	HD117
1	Bottom plate	MS173	1	Line cord with plug	WA043
1	Front panel	ME118	1	Transformer, power, 120 volt	TA126
1	Front sub-panel	MS169		or alternate 240 volt	TA127
2	Side pieces	MS171	1	Label, serial number	LR015
1	Allen wrench, L-shape, 5/32"	HZ138	1	Registration card	LM016
1	Allen wrench, L-shape, #8 set screw	HZ139	1	Owner's Manual	
1	Cable pair, audio	WA017			

THE david hafler COMPANY
 5910 Crescent Boulevard • Pennsauken, New Jersey 08109 • 609/662-6355
 Division of Rockford Corp. • 613 South Rockford Drive • Tempe, AZ 85281

HAFLEL DH-100 STEREO PREAMPLIFIER PICTORIAL DIAGRAM

© Copyright 1988. All rights reserved.

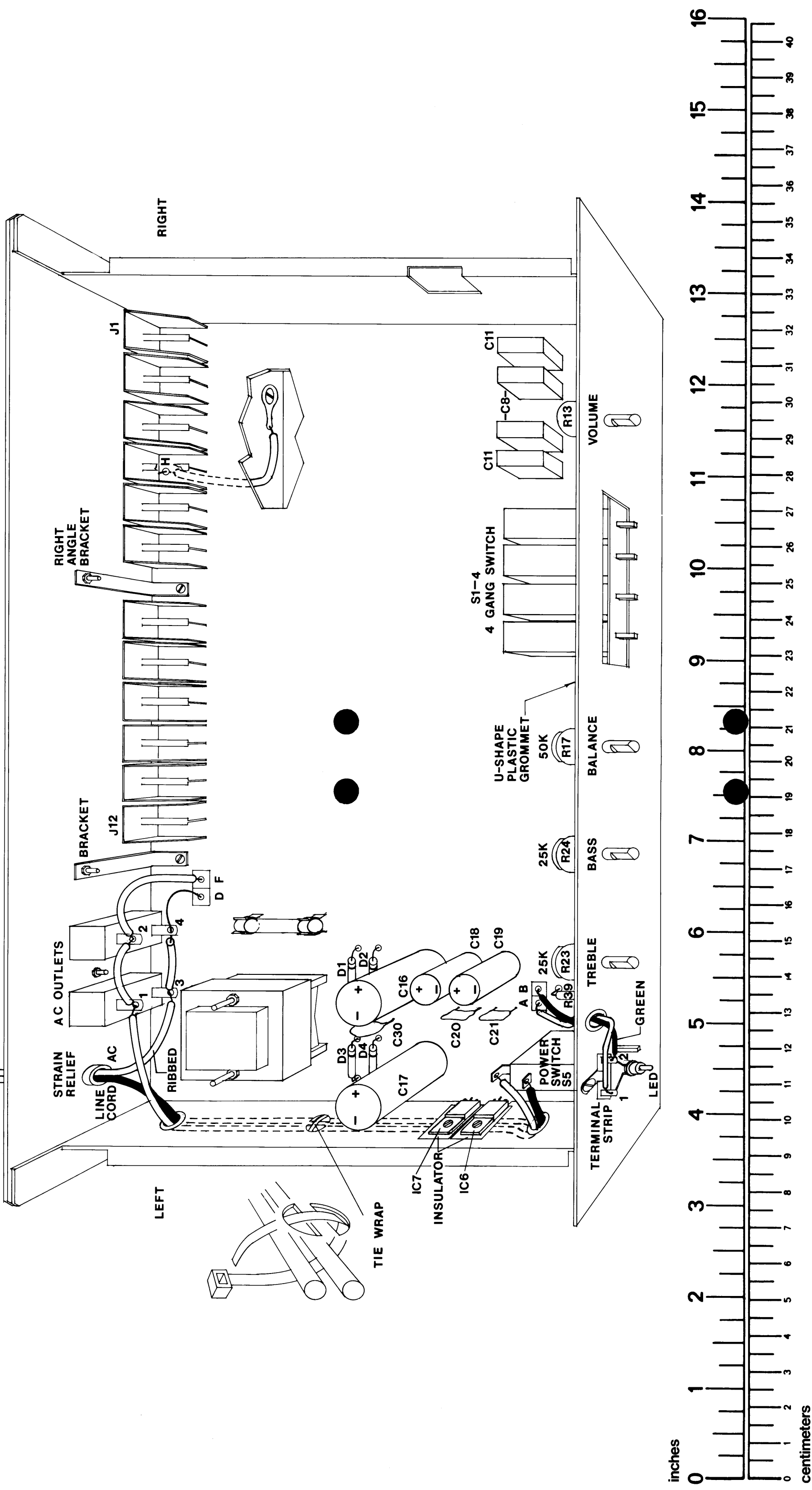

BUILDING THE DH-100 KIT

Because many of the circuit components are already installed on the etched circuit board, the essential performance of your preamplifier has already been confirmed to meet specifications before it was packed in the kit. Most of the remaining assembly is simply mechanical, but good solder connections are essential. Read the preceding section carefully if electronic kit construction is not familiar to you.

The pictorial diagram shows every connection, and the parts that you will install on the circuit board. The top of the board is marked with each component designation next to the mounting holes. Separate lists for each parts 'bag' will help you identify unfamiliar parts as you unpack them, and these, together with the pictorial diagram (which is sometimes distorted for clarity of connections) should leave no question as to where each part goes. In some cases, a specific orientation of a part is called for, and the circuit board will identify the + lead, or marked end. However, some part manufacturers will instead identify the opposite, or (-) lead on the component, so be sure you install these parts correctly.

Mechanical connections in a preamplifier must be tight, because many of them conduct electrical signals, even through the chassis. The exception will be the nylon screws and nuts used in special cases, where they should be tightened only until they resist your tools slightly, to avoid stripping their threads. It will be easier if you first separate the hardware by size and type in an egg carton, verifying the count on the parts list as a check on how they are identified. #4 and #6 nuts look almost alike, but the larger #6 size can be selected by sliding it over the single long #4 screw.

- We'll tackle the most difficult step in this kit right away—installing the AC line cord and its strain relief. This requires heavy 'gas' or slip-joint pliers because of the stiffness of the line cord. Select the back panel, the AC line cord, and the plastic strain relief. 9" from the cut end of the cord, make a sharp 'V' in the line cord by bending it back on itself with the ribbed conductor positioned as shown. Install the strain relief with the smaller diameter nearest the cut end of the cord. Crimp the two halves of the strain relief around the cord at the 'V' to partially form it before insertion into the back panel. Then grip the larger diameter section with the tips of the pliers and squeeze tightly. Avoid scratching the back panel when you insert the cord end and the smaller part of the strain relief through the hole AC from the outside. Note that the hole has 'flats' which keep the relief from twisting. It snaps into position when fully inserted.

Separate the two conductors of the line cord. Cut the **ribbed** conductor so that 2" projects from the strain relief, and strip 1/4" of insulation from the end. Strip 1/4" from the longer end as well. Twist the strands of each conductor tightly, and 'tin' each end with solder to secure the strands.

- Select the two right angle brackets and 3 sets of #6 hardware (1/2" black screws). Fasten the long leg of each bracket to the inside of the back panel at either end of the long central cutout. The third bolt simply fills the holes between the two rectangular openings for the AC outlets. This hole has no purpose in your kit.
- Select the two AC outlets. Note that one plug slot on each outlet is wider. The wider slot goes at the bottom of the back panel when you snap them in from the outside. Connect the ribbed end of the line cord to AC outlet lug #3 (wide).
- Prepare a 2" length of white wire, but strip 1" of insulation from one end. Connect the shorter bared end to AC outlet lug #3. (S-2). Pass the longer bared end all the way through AC outlet lug #4, and 3/8" beyond that lug, bend the wire downward at a right angle. Solder lug #4.
- Prepare a 1-3/4" white wire. Connect one end to AC outlet lug #2, pointing the wire toward the angle bracket.
- Prepare a 1-1/4" white wire. Connect one end to AC outlet lug #2. (S-2). Connect the other end to AC outlet lug #1.
- Prepare a 9" white wire. Connect one end to AC outlet lug #1. (S-2).

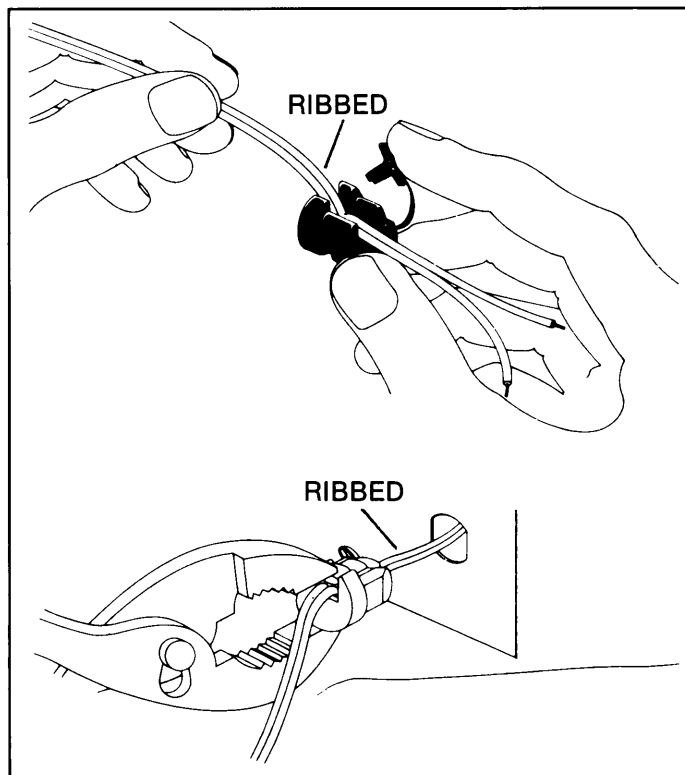

LM164

- 8 Select the ground lug, the longer bright screw, a #4 KEP nut, and the knurled thumb nut. Fasten the ground lug on the inside of the back panel with the screw head on the inside, secured with the KEP nut on the outside, at the lower hole labeled 'GND.' The ground lug should point toward the strain relief. Be sure this connection is tight. Then place the knurled thumb nut on the screw.
- 9 Prepare a 1-1/4" white wire. Connect one end to the ground lug so that the wire projects towards the strain relief. (S). Set the back panel aside temporarily.
- 10 Select the bright finished front sub-panel, and one of the rubber grommets. Orient the panel so that the two single holes are in the upper left corner, and install the grommet in the larger of the two holes.
- 11 Select the two lug terminal strip, and one set of #4 hardware. Mount the terminal strip next to the grommet on the outside (facing you with the grommet in the upper left) of the panel, below its mounting hole.
- 12 Select the power switch and two #4 screws. Mount it on the inside of the panel, below the terminal strip, so that its two connecting lugs are uppermost behind the terminal strip. Set the front panel aside temporarily.

When installing components on the etched circuit board, be sure you are using the correct holes, then make sure the part is oriented correctly if that is specified, place the part flat against the board, solder the leads on the underside of the board, and cut off the excess lead. This board has 'plated through' holes, which means that the hole is coated with metal on the inside. Solder will be drawn into the hole when it is heated along with the lead, so you do not have to leave a large mound of solder on the outside. Just be sure the connection is smooth and bright. It is expected that you will solder every component lead which passes through the board, so individual instructions will not repeat that point.

- 13 Select the circuit board and the 4 diodes, which are marked with a stripe on one end. The stripe must be on the end which is nearest the center of the board when these are installed in the locations marked D1, D2, D3 and D4, below the transformer location in the upper left corner. Solder every lead.
- 14 Select the disc capacitor C30 (502M), and install it between the diodes.
- 15 Select the 2700 ohm resistor, which has color bands red/violet/red, and install it at R39 near the left front corner of the circuit board.
- 16 Select the two .033 mfd capacitors, and install them at C20 and C21.

- 17 Select the two 470 mfd capacitors. Note that the negative lead may be marked, and/or the positive lead is longer. The hole for the positive lead is marked by an arrow on the board at locations C18 and C19. Be sure these are oriented correctly.
- 18 Select the four 1 mfd capacitors (1.0K) and install them in the lower right corner of the board, in the 2 locations marked C8 and in the 2 locations marked C11.
- 19 The 12 phono jacks will now be installed at locations J1 through J12, along the back of the board. It is important that these be mounted flat against the board, and it is also important that a phono plug be inserted in the jack while the center conductor is soldered to the board. Because the outside mounting lugs of adjacent jacks share a common hole in the circuit board, we suggest the following procedure as the simplest way to make sure all of the jacks are properly aligned.

Install the jacks in pairs, starting at J1, but temporarily 'tack solder' only the two mounting lugs in the one hole at the center of each pair. This will hold the jacks in position for checking and resoldering as necessary, until they are all in a straight, flush row. The go back and solder the remaining mounting lugs securely. After a final alignment check, go down the line and permanently solder those lugs which were just tacked in place at first. Now insert a phono plug (one end of the audio cables supplied in the kit) fully into each jack as you solder the center conductor of each.

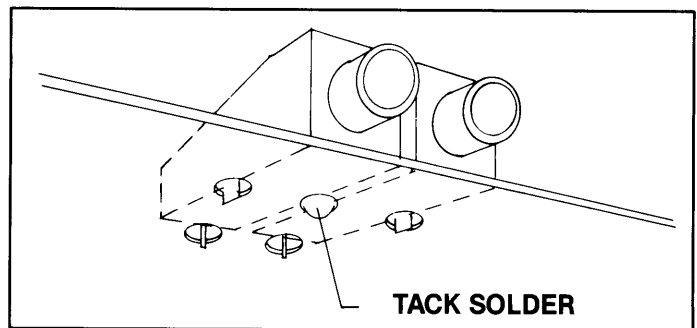

- 20 Select the four gang pushbutton switch, and note that the flat metal mounting bar will be tight against the top surface of the circuit board when the switch assembly is installed correctly. Initially tack solder two opposite corner switch lugs, and check to make sure the switch assembly is flush against the board, and that all lugs project through the board. When you are certain that it is correct, solder every switch lug securely.
- 21 The 4 potentiometers, or controls, may look alike, but only two are identical. The balance control will be marked '50K' as a part of the printed numbers on the control, but otherwise it looks like the 25K bass and treble pots. The volume control is also 50K, but it does not have the metal disc on the back. Install the volume control in the right corner of the board first. Because control position is critical for proper mounting to the front panel, and

it is very difficult to make any change after multiple lugs are soldered, we suggest that you solder only *one* lug on each control as you install them at this time. Even so, take care to position each so that it is flush against the board, and so that the control shaft is parallel to the surface of the board. Select the 50K balance control, and install it in the center location. Then install the two 25K pots in the bass and treble positions.

- 22 Select the two large 1000 mfd capacitors, and noting the + lead arrows on the board, install these at C16 and C17, just below the diodes.
- 23 Select one of the side pieces, and two sets of #4 hardware. Position the side piece on top of the left edge of the board, with the flanges pointing outward, and with the rectangular cutout above the designation for 'Regulators IC6 and IC7'. Bolt the side piece to the board.
- 24 Select the two rubber grommets and install them in the holes in the side piece.
- 25 Select the two regulators, IC6 and IC7, their 2 flat plastic insulators, 2 insulating shoulder washers, and 2 sets of #4 hardware. Install IC7, designated #7815, on the inside at the rear of the cutout in the side piece. The flat side of the regulator is towards the side piece, when the leads are inserted in the correct holes on the board. Install a shoulder washer on a screw with the larger diameter next to the screw head. Hold a flat insulator between the IC and the side piece, and insert the screw from the inside, through the IC, the insulator, and the metal side. Fasten snugly with a nut, but don't overtighten. Solder each lead on the bottom of the board. Install IC6, #7915, in the same manner in the adjacent front location.
- 26 Select the other side piece, and two sets of #4 hardware. Mount it on the board with the rectangular cutout toward the front of the board, at the top.
- 27 Select the front sub-panel assembly, and the 4 large Allen socket-head black screws. Mount the sub-panel to the board, just sliding the screws into their corner holes. They need not be secured with nuts at this time.
- 28 Select the 4 nuts and 4 washers for the controls, and secure the controls to the panel.
- 29 Solder all of the remaining lugs of the 4 front panel controls to the underside of the circuit board.
- 30 Select the power transformer and the two long nylon screws and two nylon nuts. Note the lug numbers on the transformer. Position the transformer so that these match the numbers on the circuit board, and solder each transformer lead after making sure that the transformer is flat against the board. In the 100-120 volt version used in the USA, there are no lugs at positions 2 and 3. Install the nylon screws from the *bottom* of the board, and secure with the nylon nuts, but do not overtighten these.
- NOTE: If the transformer supplied with your kit has lugs at positions 2 and 3, it operates only from 200-260 volt AC mains.
- 31 Select the back panel assembly, and 4 sets of #6 hardware. Feed the end of the AC line cord and the white wire through the rear grommet in the side piece from the inside, making sure the angle brackets are on top of the board, and secure the back panel to both side pieces.
- 32 Select the two sets of #4 hardware, and fasten the back panel angle brackets to the top of the circuit board.
- 33 Connect the short bare wire from AC outlet lug #4 to hole 'D' on the circuit board. (S). Connect the white wire from AC outlet lug #2 to hole 'F.' (S).
- 34 On the bottom of the board, connect the white wire from the ground lug to hole 'H.' Solder this on the bottom of the board. Check to make sure that the bare wire cannot protrude above the top of the board so far as to risk contacting a phono plug inserted in that socket.
- 35 Thread the line cord and white wire through the front grommet in the side piece. Connect the white wire to the rear lug of the power switch. (S). Connect the line cord to the top lug of the switch. (S).
- 36 Select the plastic wire tie and thread it through the two slots in the center of the left side piece, to secure the line cord and the white wire. This tie can be used only once, and it locks securely when the tail is pushed through the head end from the flat side. Cut off the excess after pulling it tight.
- 37 Prepare a 4" red wire, and a 3-1/2" green wire. Starting with one pair of ends even, twist these wires together throughout their length. At the even ends, connect the red wire to hole 'A' on the board, near the power switch. (S). Connect the green wire to hole 'B.' (S). Thread these wires through the rubber grommet in the front sub-panel, and connect the red wire to the farther lug #1 of the terminal strip. Connect the green wire to lug #2.

- 38 Select the red LED, and note that adjacent to one lead the red flange has a tiny flat which marks the cathode lead. This lead will be connected to the green wire, and thus to hole 'B' on the board. To position the LED properly, so that it will engage the hole in the front panel, hold the LED pointing toward you with the flat on the right side. Bend the lead upwards at a right angle, $1/8$ " behind the red base flange. Then bend the leads into an open 'V', so that they may be pushed up through the holes in the lug terminal strip. When the tip of the LED is $1/2$ " above the top surface of the square plastic switch shaft, bend the LED leads sharply outward to support the LED while it is soldered. This should position it so that the rear surface of the red flange is in a vertical line with the front of the switch handle when it is out (released). Solder the red and green wires to the lugs, as well as the two LED leads. Before you cut off the excess LED lead length, it is best to check by temporarily putting the front panel in position, after placing the black plastic switch pushbuttons on the switches for alignment.

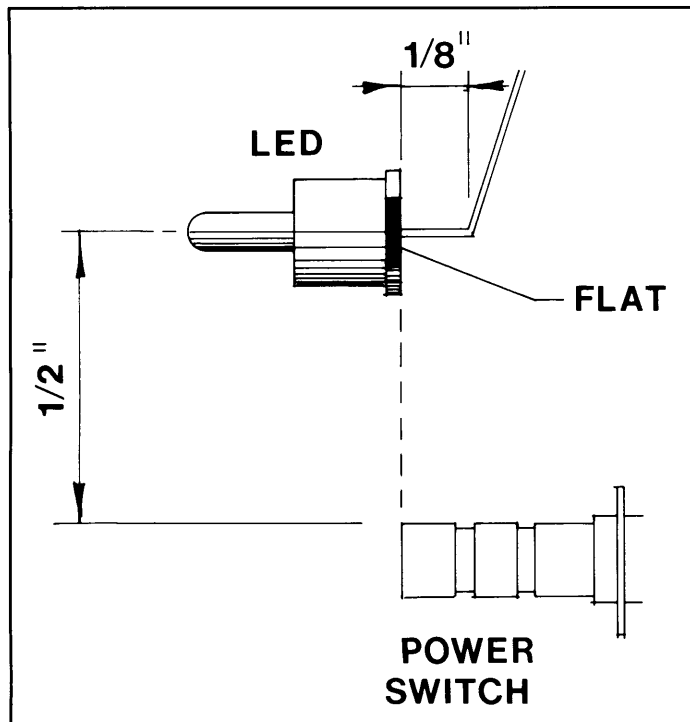

- 39 Remove the round pushbutton from the power switch shaft, and select the piece of black plastic shrink tubing. Cut a $1/4$ " length of tubing, and slip it

over the LED so that it touches the upturned leads at the rear. Hold a lighted match below it, and it will shrink to fit, and thus prevent extraneous glow from the rear of the LED.

- 40 Reinstall the round plastic pushbutton on the switch shaft, and select the 4 knobs, the 4 set screws, and the small L-shaped Allen wrench. Place a screw on the end of the wrench, and thread it into a knob. Install each of the knobs so that the set screw engages the flat on the control shaft.
- 41 Select the front panel, the two end caps, and the four large nuts. Remove the long cap screws which were temporarily holding the front sub-panel in place, slip the end caps into the ends of the front panel, and install the assembly on the chassis. Be sure the LED protrudes through the front panel hole properly. Fasten the assembly to the chassis with the four cap screws and their nuts, using the large Allen wrench.
- 42 Install the long U-shaped piece of plastic grommet over the top lip of the front sub-panel.

Make a visual inspection of the diode orientation, capacitor orientation, the green wire which is connected to the 'B' hole, and the nomenclature on the controls, as well as the general quality of solder connections on the bottom of the board. Make sure the wire to hole 'H' does not protrude too far. Check that the fuse is in place.

- 43 With 6 of the black sheet metal screws, install the bottom so that the edges turn *inward*, toward the top of the unit. The narrow edge is to the rear. Select the 4 rubber feet, remove their backing, and install them in the corners of the bottom plate, about 1" in.
- 44 Slide the cover on from the rear, and secure it with 4 sheet metal screws on the bottom, and one at the center rear. Affix the self adhesive serial number label to the center rear of the bottom.

You may wish to secure the small Allen wrench (for the knobs) to the bottom of the unit with tape, for future convenience.

CONGRATULATIONS!
Enjoy this truly outstanding preamplifier.

THE **david hafler** COMPANY
5910 Crescent Boulevard • Pennsauken, New Jersey 08109 • 609/662-6355
Division of Rockford Corp. • 613 South Rockford Drive • Tempe, AZ 85281

Free Manuals Download Website

<http://myh66.com>

<http://usermanuals.us>

<http://www.somanuals.com>

<http://www.4manuals.cc>

<http://www.manual-lib.com>

<http://www.404manual.com>

<http://www.luxmanual.com>

<http://aubethermostatmanual.com>

Golf course search by state

<http://golfingnear.com>

Email search by domain

<http://emailbydomain.com>

Auto manuals search

<http://auto.somanuals.com>

TV manuals search

<http://tv.somanuals.com>