

Coffee Dispenser

Distributeur du Café

Cafetera para Monodosis



User Manual
HCS10B

Guide de l'Utilisateur
HCS10B

Manual del Usuario Modelo
HCS10B

Haier

Quality · Innovation · Style

Download from www.Somanuals.com. All Manuals Search And Download.

IMPORTANT SAFEGUARDS

When using electrical appliances, basic safety precautions should always be followed, including the following:

- 1. Read all instructions carefully.**
2. Do not touch hot surfaces. Use handles or knobs.
3. To protect against fire, electrical shock, and injury to persons, do not immerse electrical cord, plug, or unit in water or other liquid.
4. Close supervision is necessary when any appliance is used by or near Children.
5. Unplug from outlet when unit is not in use and before cleaning. Allow to cool before putting on or taking off parts, and before cleaning the appliance.
6. Do not operate any appliance with a damaged cord or plug, or after the appliance malfunctions or has been damaged in any manner. Return appliance to place of purchase.
7. The use of accessory attachments not recommended by the manufacturer may result in fire, electric shock, or injury to persons.
8. Do not use outdoors.
9. Do not let cord hang over edge of table or counter, or touch hot surfaces.
10. Do not place on or near a hot gas or electric burner, or in a heated oven.
11. To disconnect, press the ON/OFF Button, then remove plug from wall outlet.
12. Do not use the appliance for purpose other than intended use.

SAVE THESE INSTRUCTIONS

HOUSEHOLD USE ONLY

Polarized Plug

This appliance is equipped with a polarized plug (one blade is wider than the other). To reduce the risk of electric shock, this plug is intended to fit into a polarized outlet only one way. This is a safety feature. If the plug does not fit fully into the outlet, try reversing the plug. If it still does not fit, contact a qualified electrician for assistance. Do not attempt to modify this plug in any way. Do not attempt to defeat the safety purpose of this polarized plug.

A short power-supply cord is provided to reduce the risk resulting from becoming entangled in or tripping over a longer cord. Avoid the use of an extension cord because it may overheat and cause a risk of fire. However, if you must use an extension cord, the marked electrical rating should be at least as great as the electrical rating of the appliance. The longer cord should be arranged so that it will not drape over the counter-top or tabletop where it can be pulled on by children or tripped over.

Thank you for using our Haier product. This easy-to-use manual will guide you in getting the best use of your panini grill.

Model number

Remember to record the model and serial number. They are on a label on the bottom of the product.

Date of purchase

Staple your receipt to your manual.

You will need it to obtain warranty service.

TABLE OF CONTENTS

	PAGE
Important Safeguards	1
Parts and Features	3
Operation	4
Hints for Great Tasting Coffee	6
Care and Cleaning	7
Limited Warranty	8

PARTS AND FEATURES

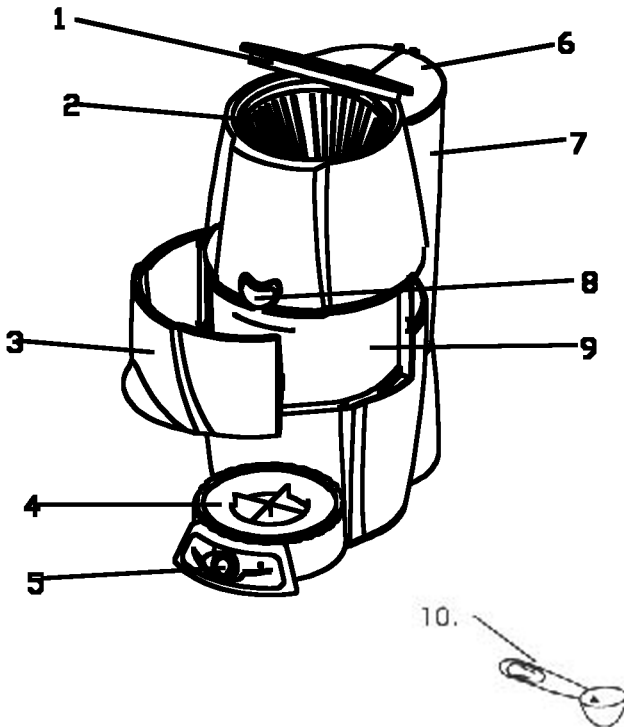

1. Coffee Filter Lid
2. Removable Filter Basket
3. Coffee Reservoir Cover
4. Drip Tray
5. On/Off Button

6. Water Reservoir Lid
7. Water Reservoir
8. Coffee Dispenser Button
9. Coffee Reservoir
10. Measuring Spoon

OPERATING INSTRUCTIONS

1. Carefully unpack the appliance. Remove and discard all packing materials.
Note: Be sure not to discard any pieces that are required for assembly or operation.
2. Before using this appliance, thoroughly clean the accessories, including the Removable Filter Basket, Water Reservoir, and Measuring Spoon in warm, soapy water. Rinse and dry thoroughly.
3. Wipe all outside surfaces with a damp, soft cloth.
Note: Never immerse the main unit in water.
4. Place the appliance on a dry, level surface.
5. Follow the instructions under the BREWING COFFEE section but brew 12 cups of fresh water only. Do NOT add coffee grounds to the paper filter.
6. When all the water has dripped into the Coffee Reservoir, press the ON/OFF Button (on the Control Panel) to turn the Coffeemaker OFF.
7. Wait a few minutes, then press the Coffee Dispenser Button to let water flow into a mug. Discard the water from the mug. Repeat until all the water has been discarded.
8. Repeat steps 5 through 7.

COFFEE FILTERS

- Cone-shaped paper filters are available locally at grocery stores. Use a #4 paper coffee filter. Permanent gold mesh filters may also be purchased, thus eliminating the need for disposable paper filters.
- The use of basket-style paper filters is not recommended. These filters do not conform to the shape of the Filter Basket and may cause coffee to back up and spill over during brewing.

BREWING COFFEE

1. Lift the Coffee Filter Lid. Place a #4 paper coffee filter into the Filter Basket.
2. Using the Measuring Spoon, place the desired amount of ground coffee into the coffee filter (see Fig. 1). Use one leveled tablespoon of ground coffee for each cup of brewed coffee. For stronger or milder coffee, adjust the amount of coffee to suit your taste.
3. Lower the Coffee Filter Lid. Always keep the lid closed during operation.
4. Lift the Water Reservoir Lid, and pour water into the Water Reservoir. Close the Water Reservoir Lid. Use only cold water to fill the Water Reservoir to the desired level (use markings on the Water Reservoir as a guide).

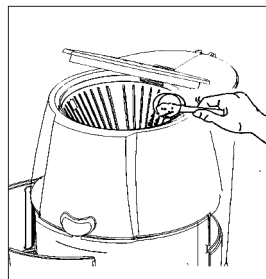

Note: The amount of brewed coffee will always be less than the amount of water placed into the coffeemaker, since about 10% is absorbed by the coffee grounds and the filter.

5. Press the ON/OFF Button once to begin brewing.
6. Keep the Coffee Reservoir Cover closed during operation to avoid burns. If the Coffee Reservoir Cover is opened during the brewing process and the Coffee Dispenser Button is pressed, the unit will turn off. Be careful not to touch the hot surface of the Coffee Reservoir when the unit is on.

CAUTION! When removing the Coffee Reservoir, make sure it has cooled completely to avoid injury.

7. If you wish to serve a cup of coffee before the Brewing Cycle is complete, place a mug on the Drip Tray (different sized mugs may be used). Press the Coffee Dispenser Button to let coffee flow into the mug.

Note: The height of the Drip Tray can be adjusted. Grasp the cross of the Drip Tray and turn either in a counter clockwise or clockwise direction to adjust if the mug is not at the appropriate height.

8. After brewing is complete, wait about one minute until the dripping has fully stopped before serving.

9. The Warming Plate (located under the Coffee Reservoir) will automatically keep the coffee at an ideal serving temperature as long as the coffeemaker is on.

Note: When the coffee is being kept warm, make sure there is coffee in the Coffee Reservoir. Check that the indicator light on Coffee Reservoir is lit.

10. Press the ON/OFF Button to turn the Coffee Dispenser off when the Coffee Reservoir is empty or when the unit is not in use.

11. To brew another pot of coffee, turn the unit off and wait 10 minutes to allow the heating element to cool. After the Coffee Dispenser has cooled, dispose of the used coffee filter and coffee grounds and rinse the Removable Filter Basket with warm water. Place a fresh coffee filter into the Filter Basket and add fresh coffee grounds to the filter.

CAUTION! If the unit is not allowed to cool before immediately reusing, water placed in the Water Reservoir may become overheated and a spray of steam could be released when opened, creating a risk of burns.

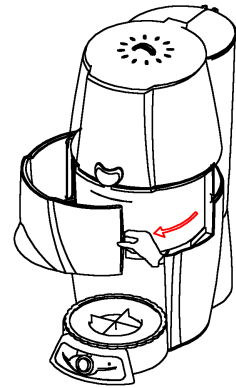

HINTS FOR BREWING GREAT TASTING COFFEE

- A clean Coffeemaker is essential for making great tasting coffee. Regular cleaning is highly recommended.
- Always use fresh, cold water in your Coffeemaker.
- Finer grinds, such as drip coffee, promote fuller extraction of flavor and produce rich, full-bodied coffee. Regular grinds will require slightly more per cup to provide the strength of a finer grind.
- Store coffee in a cool, dry place. Once coffee has been opened, keep it tightly sealed and store in the refrigerator to maintain freshness.
- For optimum coffee flavor, buy whole beans and grind them finely just before brewing.
- Small oil droplets on the surface of brewed, black coffee is a result of the extraction of oil from the coffee grounds. Oiliness may occur more frequently if heavily roasted coffees grounds are used. Cleaning your Coffeemaker regularly will help prevent oil build-up.

CARE AND MAINTENANCE

WARNING! To reduce the risk of fire or electric shock, do not remove the bottom cover. There are no user serviceable parts inside. Repair should be done by authorized service personnel only.

REGULAR CLEANING

1. Discard the paper coffee filter or rinse the permanent filter.
2. Remove the Filter Basket. Rinse and dry thoroughly. Do NOT Filter Basket in the dishwasher.
3. When cleaning the Coffee Reservoir, first make sure the Coffeemaker is turned off and has cooled completely. Swing the Coffee Reservoir Cover out and grasp the Coffee Reservoir to remove it before cleaning. Do not place any other liquid, except water or the cleaning solution as specified in this manual, into the Water Reservoir.
4. Wipe the Coffeemaker with a soft, damp cloth and dry thoroughly. Do not use abrasive soaps or scouring pads to clean the appliance. NEVER immerse the machine in water. It is an electrical appliance.

DESCALING

Mineral deposits left by water can clog your coffeemaker. It is necessary to regularly descale your coffeemaker in order to flush out these deposits. Descale your coffeemaker every 1-3 months. If you live in a hard water area, you may have to descale the coffeemaker more frequently. Excessive steaming or a prolonged brewing cycle are signs that descaling is needed. During descaling, more steaming occurs than when brewing coffee.

LIMITED WARRANTY

Full One Year

This warranty covers all defects in workmanship or materials for a period of 12 months from the date of purchase, provided you are able to present a valid proof-of-purchase (the original receipt)

Exceptions: Commercial or Rental Use Warranty is 90 days from date of original purchase.

This warranty covers appliances within the Continental United States, Puerto Rico and Canada.

What is not covered by this warranty:

Damage from other than normal use or improper installation.

Damage from misuse, abuse, accident, alteration, lack of proper care and maintenance.

Failure caused by build-up of food matter or water deposits.

Product, whose rating label has been removed or altered.

Product serviced by other than authorized service center.

Replacement or repair of household fuses, circuit breakers or wiring.

Labor, shipping charges and replacement of defective parts beyond the initial 12-month period.

Do not return this product to the store. If you need assistance with this product, please contact "Haier Customer Satisfaction Service at 1-877-337-3639 between 9:00 AM and 5:00 PM (EST) Monday to Friday.

Before calling, please have the following information available:

Model number of your appliance. The name and address of the store you purchased the unit from and the date of purchase. A clear description of the problem.

Haier will repair or replace any part free of charge including labor that fails due to a defect in materials or workmanship, or replace with a comparable model.

THIS LIMITED WARRANTY IS GIVEN IN LIEU OF ALL OTHER WARRANTIES, EXPRESSED OR, INCLUDING THE WARRANTIES OF MERCHANTABILITY AND FITNESS FOR A PARTICULAR PURPOSE.

The remedy provided in this warranty is exclusive and is granted in lieu of all other remedies.

This warranty does not cover incidental or consequential damages, so the above limitations may not apply to you. Some states do not allow limitations on how long an implied warranty lasts, so the above limitations may not apply to you.

This warranty gives you specific legal rights, and you may have other rights, which vary, from state to state.

Haier America
New York, NY 10018

IMPORTANT

Do Not Return This Product To The Store

If you have a problem with this product, please contact the "Haier Customer Satisfaction Center" at 1-877-337-3639.

DATED PROOF OF PURCHASE REQUIRED FOR WARRANTY SERVICE

IMPORTANT

Ne pas Réexpédier ce Produit au Magasin

Pour tout problème concernant ce produit, veuillez contacter le service des consommateurs 'Haier Customer Satisfaction Center' au 1-877-337-3639.
UNE PREUVE D'ACHAT DATEE EST REQUISE POUR BENEFICIER DE LA GARANTIE.

IMPORTANTE

No regrese este producto a la tienda

Si tiene algún problema con este producto, por favor contacte el "Centro de Servicio al Consumidor de Haier" al 1-877-337-3639 (Válido solo en E.U.A).

NECESITA UNA PRUEBA DE COMPRA FECHADA PARA EL SERVICIO DE LA GARANTIA

120V, 60 Hz

**Made in China
Fabriqué en Chine
Hecho en China**

Haier

**Haier America
New York, NY 10018**

HCS10B

Issued: April - 06

Printed in China

Free Manuals Download Website

<http://myh66.com>

<http://usermanuals.us>

<http://www.somanuals.com>

<http://www.4manuals.cc>

<http://www.manual-lib.com>

<http://www.404manual.com>

<http://www.luxmanual.com>

<http://aubethermostatmanual.com>

Golf course search by state

<http://golfingnear.com>

Email search by domain

<http://emailbydomain.com>

Auto manuals search

<http://auto.somanuals.com>

TV manuals search

<http://tv.somanuals.com>