

User Manual For Haier DW-86L288/388/628/386/626
DW-86W420
Ultra Low Temperature Storage Freezer



This product is suitable for ultra low temperature storage of products in applications such as clinical, pharmaceutical, scientific research, and epidemic institutions.

Haier Medical and Laboratory Co., Ltd.

- Read this user's manual carefully before using the ULT freezer.
- Place this manual in a convenient location for future reference.

0070505464



Table of Contents

General Information

Features of the Haier ULT Freezer	1
Description of Key Parts and Functions.....	2
Safety Precautions.....	3
Proper Usage.....	4
Pre-Installation Information.....	7

Pre-Start Up Instructions

Installation.....	8
Initial Loading.....	9
Temperature Adjustment and Setting.....	11
Display and Alarms.....	13

Maintenance

Routine Maintenance.....	15
Troubleshooting Guide	16
Recycle Rechargeable Battery.....	17

Technical Data

Specifications	18
Schematic Diagrams, Refrigeration and Wiring Diagram.....	19
Optional Accessories.....	20
Technical Service	24

The actual design, color and door pattern of the unit you received may vary as a result of continuous improvements.

Technical Service

Your Haier ULT Freezer has a 3 year warranty on the compressors and 5 years parts and labor on the rest of the unit.

The warranty card should be kept for future service work. Should you need service or to inquire about your freezer, please use the warranty card to contact your local Haier Equipment and Instrument Service center.

Features of the Haier ULT Freezer

- The Haier ULT Freezer is equipped with microprocessor control and a digital temperature display with a range of -10°C to -86°C . The normal operation temperature range is -50°C to -86°C .
- The unit has a number of standard protection functions. They include compressor delay protection, low voltage booster, and high voltage protection.
- The refrigeration system for the unit features a balanced cascade technology powered by low-temperature rated speciality compressor.
- Advanced LED display on the freezer can display the cabinet temperature, set point, ambient temperature and line voltage. It also allows the user to set the high temperature alarm, low temperature alarm and notifies the user that the unit has developed a failure through the display.
- Innovative and integrated design of the door lock and handle provide convenient application.

Note: Technical data published in this manual are nominal. The actual ULT performance may vary slightly due to continuous product improvements.

Description of Key Parts and Functions

Diagram of parts



Power switch for battery

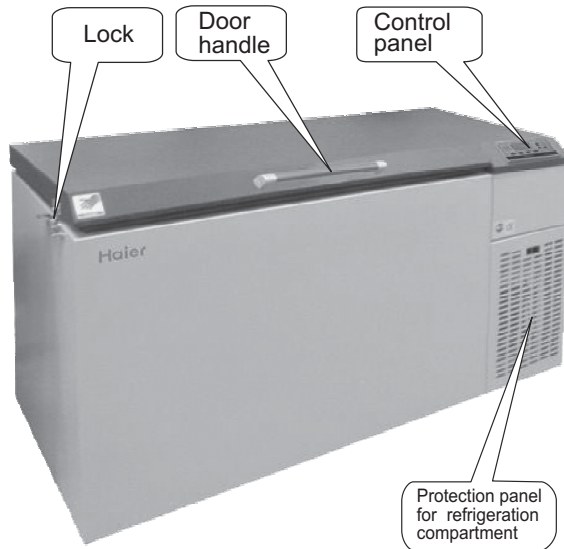

Optional Accessories

CO₂ and LN₂ backup cooling system

For installation and instructions for operation, please refer to the user's manual shipped with the system.

Warning Any equipment using CO₂ can displace oxygen in the surrounding area. Please verify that there is sufficient ventilation around the workplace. If there is limited ventilation, alternative means to ensure a safer environment must be employed. This may include air quality monitoring and warning devices.

Storage rack and box

If the unit is used to store small samples, storage racks and boxes provide more efficient use of internal space.

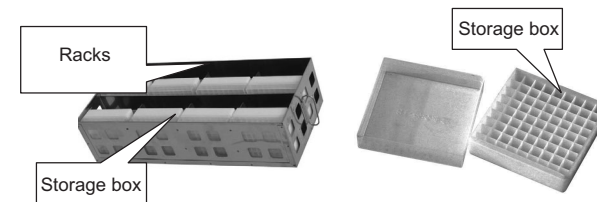

Model	Storage Rack	Box
DW-86L628	20 (2 inch)	320 (2 inch)
DW-86L388	16 (2 inch)	192 (2 inch)
DW-86L288	12 (2 inch)	144 (2 inch)
DW-86L386	16 (2 inch)	192 (2 inch)
DW-86L626	20 (2 inch)	320 (2 inch)

Optional Accessories

This recorder has been calibrated at the factory. It retains the temperature accuracy and calibration even when there is a power supply interruption. Should there be a need to recalibrate the recorder, please follow the procedures below.

- a) Let the unit run continuously until it reaches a stable condition. The recorder has registered temperature for at least two hours.
- b) Place a standard thermocouple in a 100 ml container filled with 10% glycerin solution. Place the container and the temperature recorder sensor in the unit. Do not place the recorder sensor in contact with any liquid.
- c) After four hours of soak time at the stable freezer temperature, the container temperature should match the freezer temperature. Then compare the thermocouple reading with the temperature recorder reading. If there is a discrepancy, use the button (#1) or the button (#2) on the recorder to move the pen on the chart to reflect the correct temperature.

Note: The ink pen will operate 5 seconds after the button is released.

Caution: The temperature recorder is preset during production, so resetting of the temperature recorder is not recommended unless absolutely necessary.

Safety Precautions

This manual and labels attached to the product include important safety precautions required to operate this product. Customers are advised to follow instructions provided to avoid potential damage to product and injury to operators.

Note: Use this product only in the way described in the product literature and this manual. Before using it, verify that this product is suitable for its intended use. Do not modify system components or use unauthorized parts as this will void the product warranty.



This sign is directly related to operator safety and equipment safety. The contents and instructions that follow the sign must be strictly followed.



This sign refers to prohibited actions. Violation may result in damage to the freezer or compromise the operator's safety.



This label is adhered to a cover that protects a high voltage area to reduce the chance of electric shock. Access to the cover should only be handled by a qualified engineer or technician.

NOTICE!

1. Freezer must be placed at least 200mm away from the wall to allow maximum air circulation.
2. Changing of the Refrigerants should be done according to the Service Manual.

NOTICE!

For the most efficient energy consumption and optimized compressor life, the temperature should be set at the highest temperature suitable for the samples to be stored, normally set at -50°C to -80°C.

When power to the unit is on, switch on the battery charger. When the unit is not in use switch power off and then switch off the battery charger..

Charge
battery
switch

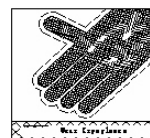

Grounding mark

Wear Cryogloves before opening the door.

Proper Usage

- ❗ The appliance requires 220V~50Hz for 628/388/288/386/310 or 220V~50Hz and 220V~60Hz for 628/626. A regulator with a capacity of 4000W or higher must be installed if the voltage is beyond the rated voltage of $\pm 10\%$. If the power cord needs to be extended, the extended conductor must have a cross area of equal or greater than 2mm^2 for 628/388/288/386/310 (220V~50/60Hz) or 3mm^2 for 628/626 (115V~60Hz), and the extended length must not exceed 3m.
- ❗ Your Haier ULT unit is equipped with a standard three-prong power plug, rated current for 20A for 628/626 (115V~60Hz) and 16A for 628/388/288/386/626/310/420 (220V~50/60Hz). Be aware that one of the three prongs is for grounding purposes. Removal of the ground prong is strictly prohibited for safety reasons under any circumstances. The electrical power plug should be securely plugged into the power socket. A loose plug in the socket may cause fire.
- ❗ The power socket intended for your Haier ULT usage must be grounded to avoid electric shock. If the socket does not meet this requirement, the condition must be corrected by a qualified technician before using the ULT unit.
- ⊘ Never use gas lines, water mains, telephone lines or lightning rods as the grounding device for your Haier ULT unit. This type of improper grounding may cause electric shock or other danger.
- ⊘ Never install your ULT in an unprotected area. After a unit is rained on, there is a danger of electric shock.
- ❗ Installation and maintenance of your Haier ULT should be carried out only after reading this manual. Haier Equipment & Instrument Services can install and validate your unit please call local Haier sales and service center.
- ❗ Your Haier ULT must be securely installed on a firm floor. A tilted installation may result in equipment falling causing injury and damage.
- ⊘ Your Haier ULT must not be installed in a damp area or an area that can be subject to water spray. A damp or wet unit may cause weakening of insulation which could lead to electric shock.
- ⊘ Never store flammable, explosive or volatile materials in the unit. To avoid potential explosion or fire, do not use any spray near the unit.
- ⊘ Never store corrosive chemicals with acid or alkaline properties in the unit as they can lead to damage to internal components of the unit.
- Do not use any hard object to explore any openings or gaps such as air ventilation ports. Accidental contact between the hard object and a moving part may result in electric shock or injury.
- ❗ If poisonous, radioactive or other harmful materials need to be stored in the unit, the equipment should be located in a safe zone. Improper usage of the equipment with this type of materials may hurt the environment or operator's health.

Optional Accessories

- 2) Remove the supplementary power supply
Power LED light continues to flash. The recorder works normally. It suggests that the main power supply is sufficient while the backup battery lacks capacity. It is then necessary to replace the battery until the green LED lights up and stops flashing.
- 3) Changing of Recorder Chart Paper
When changing the chart paper for the recorder, please use the following steps.
 - a. Locate the button (#3) at the front of the recorder.
 - b. Press and hold the button (#3) for about one second. The imprinting stylus of the recorder moves to the left side of the chart.
 - c. When the stylus is completely off the chart, unscrew the center nut for the paper and remove the old chart paper off the recorder. Place a new chart paper on the recorder. Carefully match the day and time line on the chart with the reference mark on the recorder panel (there is a small groove on the front of the recorder as shown in the figure).
 - d. Place the center nut over the chart paper and tighten it. Press the button (#3) to move the stylus back to the chart to continue the temperature recording.
 - e. Inspect the contact between the pen and the paper chart. Adjust the arm if necessary to make contact. (Note, do not damage the pen and arm. It might be easier to remove the arm and pen to make a small bending adjustment and then install the pen back on the recorder. Repeat the process until the recorder arm and pen work properly.)
 - f. The accuracy of the temperature must be checked after changing the chart paper. The procedure is described as follows. Press and hold the button (#3) until the pen moves to the outside of the chart paper. Then press the button (#3) again; the pen should return to the chart paper area. When the pen reaches the outer most circle of the chart paper, it pauses for a moment. If the pen does not match the outer circle of the chart marks, you can use the button (#2) or the button (#1) to move the pen to match the line. This must be done within 5 seconds after the pen pauses. If the calibration is incomplete, repeat the same process until the pen matches the outer circle line.
- 4) Calibration of Temperature Recorder

Optional Accessories

1. Temperature recorder

The ULT Freezer is equipped with a 6-inch temperature recorder for the chamber temperature. When the unit is powered up, the recorder starts working.

For proper operation of the temperature recorder, please follow the procedures below.

1. Open the recorder door to access the recorder.
2. Plug in the 9 volt battery located on the upper right corner of the recorder. This battery is a standby power.
3. Install a new chart by following the diagram below.

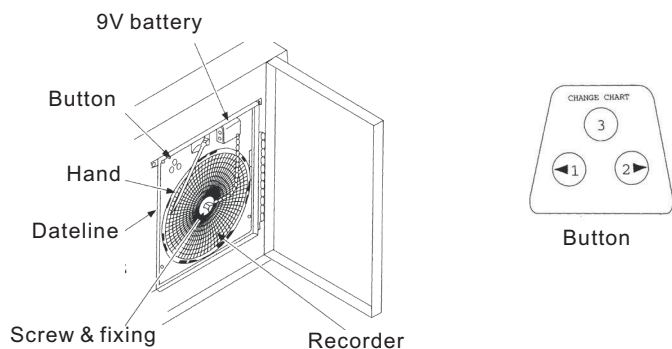

(Figure 5)
The Temperature Recorder

2. Power supply

The temperature recorder requires an AC power supply. If AC power supply is interrupted, the LED of the recorder blinks and the warning indicator turns on. The temperature recorder can also be operated with DC from spare source battery which lasts about 30 hours. (Caution: The battery should remain fully charged. If the unit is not in operation, the battery should be switched off. Ensure that the battery is in good status as a spare power source.) If power fails, the LED of the temperature recorder blinks until AC power is supplied or spare power source is connected. The LED indicator will blink when the power in the battery is low.

Replacement of Recorder Battery

When the green LED on the recorder flashes, there are two ways to inspect the unit.

1) Supplementary power supply (9 volt DC)

If the LED light is off and the recorder stops working, it would suggest that there might be issues associated with the main power supply. Please inspect whether there is a loss of power, a short circuit, or a loose connection. If there is no issue with the main power supply and the recorder starts working normally, please install the backup battery to the recorder. At this time, if the LED stops flashing, the supplementary power supply is normal. If the LED continues to flash, it means that the power supply is under capacity requirement. It is necessary to replace the battery. The LED green light is off when there is sufficient power to the recorder.

Proper Usage

- ❗ If there is leakage of petroleum gas or another flammable gas, close the gas supply valve and open doors and windows to ventilate the air. Do not plug or unplug your freezer unit.
- ❗ While the equipment is repaired, take precautions not to inhale any chemicals or aerosols existing near the unit. They might be harmful to your health.
- ⊘ Never directly pour water into the unit. The water may cause electric shock or short circuit.
- ⊘ Customers must not dismantle, repair or modify the equipment. Such improper operations may result in fire or personal injury.
- ❗ Should there be a malfunction in the equipment, power off the unit and unplug the power cord from power supply. Continuous operation with an abnormal condition may result in electric shock and fire.
- ❗ In the event there is a power outage and recovery, be sure to wait for 5 minutes before the unit power is turned back on. This is to reduce the chance of damage to the compressors and refrigeration system. During a repair operation, power must be disconnected. The power cord should always be protected to avoid damages.
- ❗ When unplugging the power cord from the socket, use a firm grip on the plug itself for pulling. Do not pull the power cord as this action may strip the wires off the plug causing electric shock, electrical short circuit and fire.
- ❗ Maximum loading on the each shelf should be not more than 50kg and total loading for whole unit should be not more than 200 kg. Heavier loads may cause damage to the shelving system .

Proper Usage

- ❗ Do not touch any electrical components or power cord if your hands are damp or wet. Such action might lead to an electric shock.
- ⊘ After restarting your unit after a power outage or shutdown, ensure that all settings are correct. Accidental change in setting may damage the stored products.
- ❗ Do not place any water container or heavy object on top of the unit. A falling object may injure an operator. If the water spills into the unit, it may damage the insulation causing electric shock.
- ⊘ Do not climb on top of the unit or place any object on top of the unit. Falling equipment may cause injury or property damage.
- ⊘ Hold firmly onto the handle to close the door to avoid pinching your hands.
- ❗ Do not place any glass container or enclosed container in the freezer. These containers may crack at cold temperatures causing injury to operators.
- ⊘ Do not use bare hands to directly handle the stored products. The cold temperature of the products and the interior wall may cause the skin to burn.
- ⊘ During any repair operation, gloves should be worn to avoid injury by sharp edges or corners.
- ❗ The air filter for the condenser should be cleaned regularly. Freezer temperature could be compromised.
- ❗ If a unit is out of service for a long period of time, make sure the power cord is unplugged. Deteriorated insulation on the power cord may lead to electric shock or fire.
- ⊘ When a CO₂ backup system is activated, the ventilation in the freezer room must be monitored. Increased CO₂ concentration in the air can be harmful and even fatal.
- ❗ Do not tilt the unit more than 45 degrees when moving the unit.

Schematic Diagrams, Refrigeration and Wiring Diagram

Refrigeration diagram

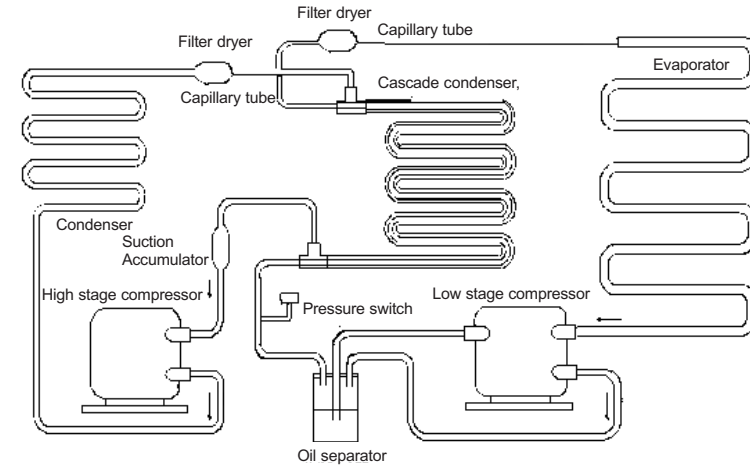

wiring diagram

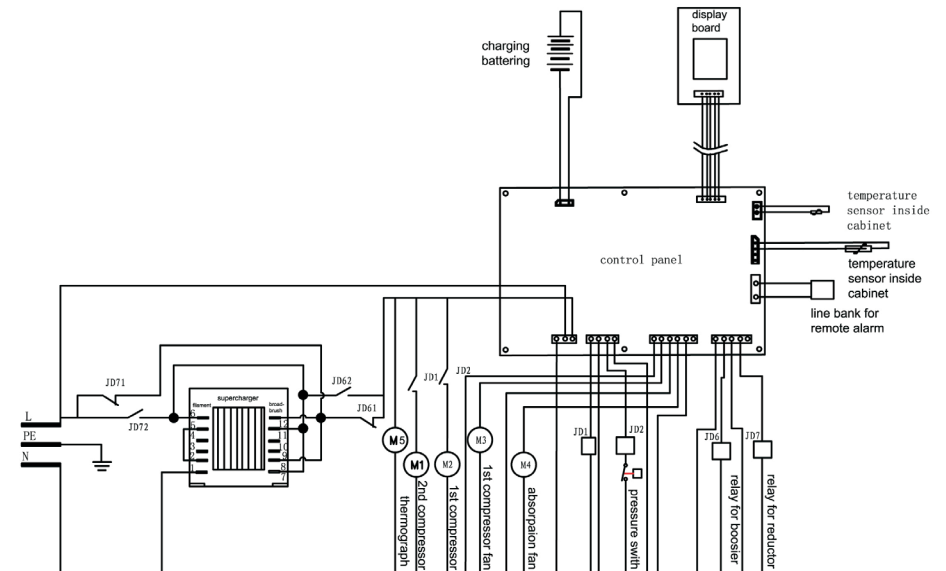

Note: The way of connection the transformer pin: for 120V: connect 1 with 5, connect 2 with 6; for 240V: connect 2 with 5.

Specifications

Description	Ultra Low Temperature Storage Freezer
Model Description	DW-86L628/388/288/386/626 DW-86W310/420
Exterior wall material	Coated cold rolled steel
Interior wall material	Coated zinc cold rolled steel
Inner doors	Aluminum framed PS board
Shelves	Adjustable stainless shelves
Porthole for testing	25.8 mm diameter X 1 Located on back wall
Insulation	Vacuum insulated with polyurethane foam(non-CFC)
Compressors	High stage/Low stage: hermetically sealed
Evaporator	Copper tube
Condenser	High stage: Finned coil Low stage: tube in tube heat exchanger
Refrigerant	R134a R404a R290 R23
Temperature controller	Microprocessor controller
Temperature display	Digital display
Temperature sensor	RTD Pt 100 ohms
Alarm device	High temperature alarm, low temperature alarm, power outage alarm, ambient temperature alarm, dirty condenser alarm, battery alarm, voltage alarm
Remote alarm terminals	Maximum load is 24 VDC at 1A
Battery	Rechargeable 12 VDC, automatically rechargeable
Accessory	Defrost scraper

Note: design parameters may vary. No further notice is available.

Technical data

Model	DW-86L628	DW-86L388	DW-86L288	DW-86L386	DW-86L626	DW-86W420
Ambient temperature (°C)	10~32	10~32	10~32	10~32	10~32	10~32
Circuit breaker	I	I	I	I	I	I
Temperature range (°C)	-50~-86	-50~-86	-50~-86	-50~-86	-50~-86	-50~-86
Net volume (L)	628	388	288	386	626	420
Rated voltage (VAC)	220 120 220	220	220	220	220 120 220	220
Rated frequency (Hz)	50 60 60	50/60	50	50	50 60 60	50
Rated current	7 18 9	6	6	6	7 18 9	6.4
Weight (kg)	301	255	217	255	301	310
Dimensions (WxDxH)(mm)	1035*900*1960	915*870*1970	915*870*1641	915*870*1970	1035*900*1960	2130*870*1020
Connection type	Y	Y	Y	Y	Y	Y

Note: At 25°C ambient, the unit's maximum cold temperature can reach -86°C.

Packing list

Model	DW-86L628	DW-86L388	DW-86L288	DW-86L386	DW-86L626	DW-86W420
User's Manual	1	1	1	1	1	1
Plastic bag	1	1	1	1	1	1
Ice scraper	1	1	1	1	1	1
Key	/	/	/	2	2	/

Pre-Installation Information

- When a ULT unit has been placed in storage or out of service for a long time, its battery should be tested for low capacity because the battery may have already released all of its energy. It does not mean the unit is in a malfunctioning condition. Should this condition occur, please run the unit for about 6 days to fully charge up the battery.

- When the unit operates normally, the unit frame at the front near the door may be slightly warm. This phenomenon is normal because hot tubing is embedded there to prevent condensation from forming on the frame.

- Before samples are loaded into the unit, make sure that the unit temperature has reached the set point then load the samples into the freezer in batches. This method can reduce the temperature rise as the load is being introduced.

- The temperature display indicates the temperature where the temperature sensor is mounted inside the unit chamber. Temperature uniformity within the chamber may vary from the sensor location due to loading patterns or insufficient temperature stabilization time.

- An access port is installed in the back wall of the unit which can be used as the through hole for the thermocouple wires during testing and validation. After all test wires are let through the access port, make sure that the gap in the port is sealed properly with insulation materials. Otherwise, the unit temperature may not come down to the desired temperature. The port ring in the outer wall can also accumulate frost and ice.

- When cleaning the unit, mild or neutral detergent solution should be used. (Non-diluted cleaning chemicals can damage the plastic portion of the unit. For directions on making a cleaning solution, please refer to the detergent section in the instructions). Never use a hard wire brush, acid, gasoline, detergent powder, polishing powder, or hot water to clean the freezer as these tools and materials can damage the powder coating and surface of the plastic. Particularly, never use gasoline or a solution with volatile chemicals to clean plastic or rubber parts.

- After the freezer runs for some time, a layer of frost usually forms on the interior liner and inner doors. When this layer of frost gets too thick, it can negatively impact the refrigeration performance of the unit. Energy consumption can increase. If the thickness reaches about 5 millimeters, please use the provided scraper to remove the frost.

- Before removing the frost, temporarily transfer the stored samples to another freezer. This reduces the chance of property loss due to rising temperatures.

- Behind the interior walls, there are many refrigeration tubes. Do not use a knife, an ice pick, or a screwdriver to cut ice and frost. This can potentially damage not only the liner but also the refrigeration tubes.

- If the freezer is not in use for a long time, please turn off the power and switch off the backup battery. The power cord should be unplugged.

Installation

Environment

- 1.Ambient temperature: The Haier ULT is designed to operate between 5°C to 28 °C .The maximum ambient temperature is 32°C . For best results, the operating ambient should be in between 18°C to 25°C . If necessary, use an air-conditioning system to achieve the required ambient condition.
- 2.Relative humidity in environment: At a normal temperature, the maximum relative humidity should be less than 80 percent. At an environment of 32°C , the maximum relative humidity is 57 percent.
- 3.The intended location should be low in dust count.
- 4.The intended location should be vibration and shock free.
- 5.The highest elevation the unit can work safely in is 2,000 meters from sea level.
- 6.Input voltage should be within 220 or 120 VAC $\pm 10\%$.

Notes: 1. An ultra low temperature freezer is usually sensitive to its operating environment. If a unit is installed outside the conditions mentioned above, it cannot operate reliably. Please improve the environmental conditions before using the equipment.

2. It is prohibited to use the unit in an outdoor place. After the unit is rained on, there is a danger of electric shock.

Location for installation

For the equipment in order to achieve an optimal operation condition, an intended installation location should satisfy the following requirements.

- 1.Do not install the unit in a room where there is little room to work on the unit should there be a malfunction. The doorway should be large enough for the unit to freely enter or exit the room if necessary. This is to allow the unit be repaired easily to avoid damage to property.
- 2.There should be at least 30 centimeters space all around the unit for good ventilation for heat removal.
- 3.The location for installation should be flat and firm.
- 4.There should be good ventilation and no direct sunlight.
- 5.The freezer unit cannot share the same power socket with another piece of equipment. The power plug should be securely connected with the power socket.
- 6.The power cord for the freezer should not be twisted or pinched.
- 7.If there is a need to extend the power cord, the extension should be rated for 220 VAC at 16 A and 120 VAC at 20A .
- 8.Before using the freezer, check the voltage supply. A voltage stabilizer to deliver 220 or 120 VAC ± 10 percent is recommended for areas where the voltage is known to be unstable. The voltage stabilizer should be rated at least 4 kilowatts.
- 9.A proper grounding terminal must be guaranteed.
- 10.If the power socket is connected with a ground terminal, make sure to inspect it for proper connection before using the equipment with it.
- 11.If the socket does not have a ground connection, it must be installed by a qualified technician.

Recycle Rechargeable Battery

The Haier freezer is equipped with a rechargeable battery. This battery is recyclable. When the battery reaches the end of its life, please contact a local recycling organization for inspection or properly discard the battery.

1.Location of the battery

The battery in the freezer is for the power outage alarm. It is located inside the control box in the lower left behind the panel.

Warning There are high voltage components in the control box. To prevent electric shock, a qualified technician or engineer should open the cover.

2.Removal of the battery

- Turn off the power to the unit and unplug the power cord from the socket.
- Use a screwdriver to remove the screws on the side panel and take down the side panel.
- Use the screwdriver to remove the cover for the control box.
- Remove the bracket that fastens the battery. Remove the battery.
- Follow regulations to recycle the battery or discard it properly.

Caution

When changing the battery, you must make sure that the brown wire connects to the positive of the battery, and the blue wire connects to the negative of the battery. The polarity must not be reversed. Incorrect polarity can damage the charge board so that it cannot charge the battery.

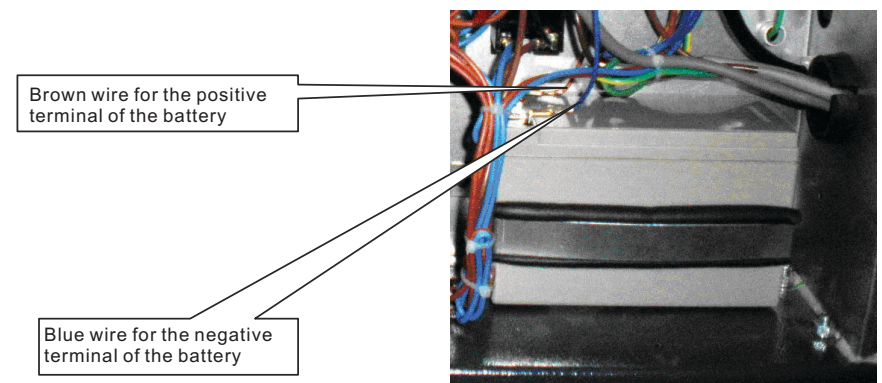

Troubleshooting Guide

Should there be any malfunctions in the system, please attempt to answer the following questions before notifying maintenance or calling Haier Equipment & Instrument Service Center

Freezer does not start up.

- Is the power supply normal? Has the main power switch been turned on yet?
- Is the voltage supply too low?
- Is a larger amount of load placed into the unit at one time?

Freezer's refrigeration ability is reduced.

- Is the environment temperature too high?
- Are the inner doors and outer door closed properly? Does any ice and frost damage the seal between the door and the frame?
- Is the condenser filter clogged?
- Is the temperature setting correct?
- Is the freezer far away from any direct sunshine?
- Is the freezer near any heat source?
- Is the porthole plug installed in the porthole with proper insulation materials?
- Has the freezer been loaded with too many non-frozen samples within the last few hours? If so, the problem is temporary. You can set the temperature to a higher value to let the freezer cycle at temperature then gradually lower the set point temperature until it reaches the desired temperature.

The unit is noisy.

- Is the unit set on a firm floor?
- Does the exterior of the unit touch any objects?
- Is the freezer unit leveled with the leveling legs?
- Does the freezer operate in a low temperature zone? If the load is heavy, and the cabinet temperature is warm, the unit may emit noise. The noise level would decrease as the cabinet temperature gets colder.
- Is the noise emitted from the compressors? ULT compressor noise tends to be higher than that of a household refrigerator unit.
- The noise might be a crackling sound. This is probably the result of contraction of internal mechanical parts due to rapid cooling inside the equipment. Stepwise pulldown in temperature with slower temperature change can reduce this noise.

Initial Loading

Installation

- 1.Remove all packing materials and straps.
- 2.Adjust support legs

Rotate the leveling legs clockwise to extend them out to anchor to the floor to ensure the unit does not move while in usage.



- 3.Grounding

Warning A socket with proper grounding must be used for the equipment. If the socket is not grounded, an upgrade of the power socket to include grounding must be done by a qualified technician. Do not use gas lines, water mains, telephone lines or lightning rods as the grounding device as they can lead to electric shock. After the unit's power cord is plugged into the power socket, the plug must be easily accessed. This allows a quick disconnect of the unit from the power supply in case of an emergency. The condenser inlet must not be blocked at anytime.

Test and adjustment

When the unit is started the first time, please follow the procedures below.

- 1.Leave the unit standing in its intended location for at least 24 hours before switching the power on.
- 2.While keeping the unit empty, plug in the power cord to a dedicated power socket that meets all requirements.
- 3.Please turn on the power switch for the rechargeable battery located on the control box in the back the unit. This control box is visible from the back of the unit. If this switch is in the "OFF" position, there will be a low battery alarm during functional test.
- 4.If the unit has a backup cooling system, turn off the backup system.
- 5.If the alarm buzzer sounds, press the cancel button to silent the alarm.
- 6.Set the unit to desired temperature:Do not load the unit with any samples. Power up the unit to let it run down to -60°C . Let it run at -60°C for 8 hours then lower it to -80°C . Observe the unit performance for 24 hours for normal cycling to ensure it is working properly.
- 7.Once the unit is confirmed to operate properly, it is ready to be loaded with samples. In principle, the freezer unit should be set at about 3°C above the desired set point. For example, if the storage temperature is -60°C , set the unit at -57°C . Load the unit to 1/3 of the unit's capacity. Make the unit is capable of cycling for more than 8 hours.
- 8.If the unit has a backup cooling system, turn on its control.

Initial Loading

Warning

- Your Haier ULT unit should be cared for by dedicated personnel. Every 2 to 4 hours, the unit's working status should be inspected and recorded on a daily basis. Should there be a malfunction in the unit, the freezer temperature rises. If the problems cannot be corrected in a short time, please remove the stored samples; move them to another unit that meets the temperature requirement to avoid potential damage of property.
- Before loading the samples into the unit, make sure to check if the required storage temperature matches the temperature capability of the freezer. This is to avoid any property damage due to insufficient storage temperature for the samples intended to be stored in the freezer.
- Because it takes time for refrigeration temperature to reach the stored samples, there is normally a temperature discrepancy between the actual shown temperature and the set point. This is a normal phenomenon. The lower the set point is, the smaller this temperature discrepancy becomes.

Caution

- All ultra low temperature storage units are low temperature storage equipment. It is prohibited to load an excessive amount of samples into the unit at one time. The compressors run for a long period of time without stopping. The freezer temperature may not decrease, and the compressors can become overheated. Samples must be loaded in batches, and in stepwise decreasing temperature setting. The process should be repeated until the final temperature is reached.
- Do not use any unauthorized mechanical means to remove or defrost the unit.
- Do not damage the refrigeration circuit.
- Do not use any non manufacturer-approved electrical components in the freezer.

Operation after a power outage

Your Haier ULT freezer control setting is stored in its memory system. Should there be a power outage and the power recovers, the unit can resume its operation based on the prior set control settings.

Routine Maintenance

Warning: To prevent electric shock or injury to operators, the AC power supply to the freezer must be disconnected completely before any repair and maintenance work is to be performed. During any repair maintenance work, do not breathe in medical particles or aerosols near the equipment as they might be harmful to your health.

Cleaning the freezer

- Clean the unit once a month. This can help the exterior look new.
- Use a dry cloth to wipe off loose dust inside and outside of the freezer. If the unit is rather dirty, use a clean cloth soaked with neutral detergent to clean the unit. Then use a dry cloth to wipe off the left over detergent solution. Non-diluted detergent can harm plastic surfaces. Please follow the instructions on how to mix a detergent solution.
- Do not pour water directly onto the exterior and interior of the unit. Water can damage the electrical insulation causing malfunction.
- Compressors and other mechanical parts are hermetically sealed. They do not need lubrication.
- Clean the frost and ice off the unit once a month. Also, clean the condenser filter once a month.

Clean the condenser filter

When the control panel shows an alarm signal for Hot Condenser, the alarm light flashes. The condenser filter must be cleaned to avoid compressor overheating and to improve refrigeration efficiency. Even if the light is not on, the filter should still be cleaned once a month. To clean the filter, follow the procedure below.

1. Pull off the front grill cover.
2. Pull out the filter screen.
3. Use water to wash the filter screen.
4. Install the screen back in its original position and close the cover.
5. If the Hot Condenser light is on before cleaning, check the light to make sure the light is off after cleaning.

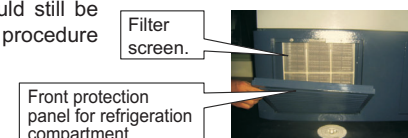

Defrost the interior

Frost usually forms in the upper portion of the unit and the on the inner doors. Frost and ice can form in between the door gasket and frame to form an air gap. It can decrease the refrigeration effect of the unit. Follow the procedure below to defrost the interior doors using the plastic scraper. The first step is to move the samples to another freezer before the procedure. Do not use any sharp tools such as knife or screw driver to defrost.

1. Remove the samples from the unit that needs to be defrosted. Move them to another unit or a container with a CO₂ backup system for temporary storage.
2. Turn off any backup refrigeration system if there is one.
3. Turn off the power supply.
4. Open the outer door and inner doors to let the unit thaw for a period of time.
5. Use a dry cloth to soak up and remove the water on the floor of the unit.
6. After defrosting the unit and cleaning up the water, restart the unit.
7. Load the samples back into the unit after it reaches the set temperature.
8. Turn on the backup refrigeration system if necessary.

Changing battery

The battery that supports the power outage alarm is a consumable item. The life expectancy for the battery is about 3 years. If the battery is more than 3 years old, the battery should be replaced because the alarm function may not work properly, and the stored capacity could also be reduced. To do so, please contact Haier Equipment and Instrument Service center.

Display and Alarms

Notes:

- A flashing alarm light cannot be cancelled unless the root cause for the alarm is eliminated. The buzzing alarm can be temporarily silenced for 30 minutes by pressing the alarm silence button. However, if the problem is not fixed, the buzzer alarm will resume after 30 minutes.
- The freezer is equipped with a rechargeable battery controlled by a power switch. Before operating the freezer, this switch must be turned on. Once the unit is plugged into the specified voltage, the unit operates to charge the battery. When there is a power outage, the battery sustains the temperature display. If the battery voltage is less than a threshold, the temperature display turns off. While the battery is still capable of providing power to the display, the temperature display can be turned off by unplugging the power cord and turning off the battery control switch.
- The freezer is also designed to auto-adjust the inner temperature set point at high ambient. When the ambient temperature is warmer than 32°C and the set point temperature is set to be lower than -82°C, the set point temperature will automatically default to -82°C. If the ambient temperature is equal to or cooler than 32°C, the set point will resume to the intended inner set point. This feature extends the life expectancy of the freezer.

Buzzer alarm resumption after cancellation

When the unit is in the alarm mode, you may press the “Silence” key to stop the buzzing of the alarm. However, the remote alarm cannot be cancelled. If the alarm condition still persists after 30 minutes, the buzzer alarm resumes automatically.

Remote alarm terminals

Remote alarm terminals are located in the machine compartment in the back of the unit. The alarm signal is delivered via the terminals. The terminals are rated for 24 VDC at 1 A. The power for remote alarm system must be connected with the wire or battery with UL certificate.

Terminal output

Under normal operating conditions, the terminals with wires are open. When the unit is in the alarm mode, the two terminals with wires are in the closed mode. The following schematic is a wiring diagram.

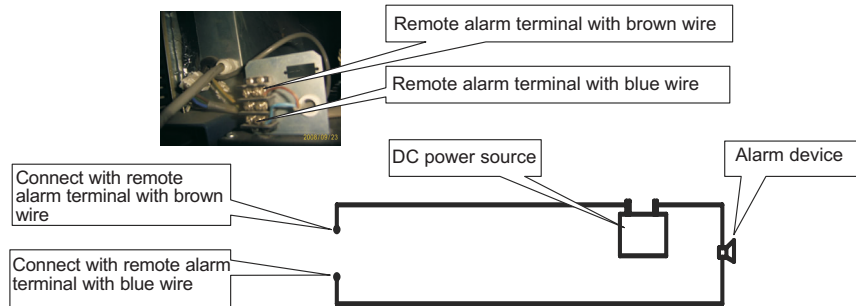

Temperature Adjustment and Setting

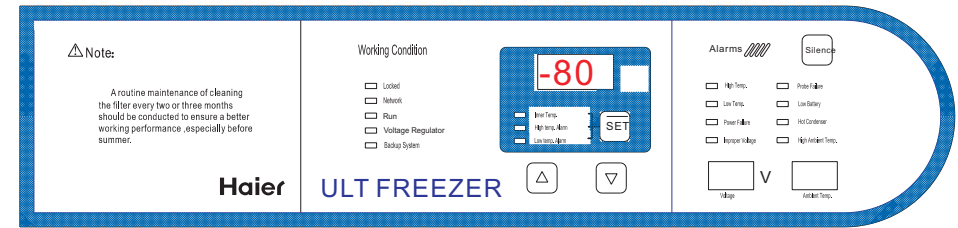

The procedure to change the freezer temperature is as follows.

1. In order to change the setting of the freezer, the freezer's control must be unlocked first. The temperature display flashes when the up or down arrow is pushed. Push the up or down arrow again to change the display to security code mode then enter the initial value 06. Push the “SET” key for 5 seconds. The locking sign turns off. This means the unit is in unlocked mode. Push the “SET” key again to select the mode for the temperature set point value, high temperature alarm value and low temperature alarm value. The matching indicator lights up as each function is chosen.

2. Freezer temperature set point: Push the “SET” key. Once the Inner Temp. indicator is on, the temperature set point area flashes. To change the temperature set point, push the “△” or “▽” key intermittently to increase or decrease the temperature setting by 1°C. After the adjustment is done, do not make any further changes for 10 seconds. The temperature display stops flashing. The unit enters the locked mode. The temperature range is -10°C to -86°C.

3. Setting of high temperature alarm: Push the “SET” key to turn on the High Temp. Alarm light. The temperature display flashes. To change the high temperature alarm of the unit, push the “△” or “▽” key intermittently to increase or decrease the temperature setting by 1°C. After the adjustment is complete, do not make any further changes for 10 seconds. The temperature display stops flashing. The unit enters the locked mode. When the freezer temperature is warmer than the high temperature alarm set point, the unit's alarm sounds, and the high temperature alert light flashes. High temperature alarm set point can only be set to a value of at least 5°C warmer than the set point temperature of the unit. The high temperature alarm value cannot be set to exceed the maximum limit.

4. Setting of low temperature alarm: Push the “SET” key to turn on the Low Temp. Alarm light. To change the high temperature alarm of the unit, push the “△” or “▽” key intermittently to increase or decrease the temperature setting by 1°C. After the adjustment is complete, do not make any further changes for 10 seconds. The temperature display stops flashing. The unit enters the locked mode. The low

Temperature Adjustment and Setting

temperature alarm set point can only be set to a value of at least 5°C colder than the set point temperature of the unit. It cannot be set to the lowest temperature limit.

5. Setting the security code: When the unit is first setup to operate, the security code to unlock the control is 06. After unlocking the unit, simultaneously push “SET” and “Silence” for 5 seconds. The display will show 06. Use the “△” and “▽” key to change the security code. The choices are from 05 to 30. After a number is chosen, do not touch the unit for 5 seconds. The control system will enter the locked mode. The new code is effective.

6. Setting the Startup delay timer: In order to reduce the startup power surge after a power outage, your Haier ULT incorporates a startup delay feature. This feature can alter the startup sequence of the compressors in the freezer. After the control is unlocked, simultaneously push “SET” key and “▽” key for 5 seconds. The temperature display shows the time delay to be 01 for 1 minute for the high stage compressor to start after power up. This delay can be changed by pushing the “△” or “▽” key to change the value from 1 minute to 10 minutes. The default value for this delay is 1 minute. If this time delay startup is set at more than 5 minutes, the equipment would take too much time to pull down the freezer temperature. If the power source has sufficient capacity, there is no need to change the default value.

7. Alarm test and low battery test: When the ULT unit is powered up, simultaneously press the "Up" arrow and "Alarm Cancel" buttons for 5 seconds. The buzzer alarm should sound and the alarm indicator should flash. At this condition, the 6 second test procedure starts. If the battery capacity is low, the low battery light indicator will flash 6 times. If the battery is at full capacity, the low battery light does not light up or flash. After 6 seconds, start the unit up. All indicators will light up for 6 seconds without flashing. All electronic display windows will indicate a digit of 8 for 6 seconds. When this is done, all display functions work properly.

Display and Alarms

Display and alarm

When the freezer is powered up, the display will show the actual freezer temperature, set point temperature, and current voltage.

The display shows the following indicator lights.

- Locked indicator: When the light is on, it means all set values are in the locked mode. This is to prevent erroneous operations.
- Network indicator: The indicator suggests that the network is in working mode.
- Run indicator: When the light is on, it means the compressors are in working mode.
- Regulator indicator: The lit indicator means the voltage stabilizer is in working mode to boost or buck the voltage.
- Backup System indicator: The lit indicator means that the backup cooling system is in working mode.

Alarm Conditions

Alarm	Alarm Triggng Condition	Indicator	Buzzer Sound
High Temperature Alarm	When this indicator is on, the units temperature reaches the warm alarm limit.	Alarm indicator flashes.	Buzzer delays 15 minutes to sound intermittently.
Low Temperature Alarm	When this indicator is on, the units temperature reaches the low alarm limit.	Alarm indicator flashes.	Buzzer delays 15 minutes to sound intermittently.
Power Failure Alarm	Equipment loses power.	Alarm indicator flashes. Display shows temperature and blank interchangeably.	Buzzer delays for 1 minute to sound intermittently.
Voltage Improper Alarm	Supply voltage exceeds the high or low limits.	Alarm indicator flashes.	Buzzer delay for 1 minute to sound intermittently.
Hot Condenser Alarm	1. Condensers filter element is clogged. 2. Ambient emperature is too high.	Alarm indicator flashes.	Buzzer sounds intermittently.
High Ambient Temperature Alarm	Ambient Temperature exceeds 32°C.	Alarm indicator flashes.	When ambient temperature exceeds 38°C, buzzer sounds intermittently.
Probe Failure Alarm	Main cabinet temperature control sensor fails.	Alarm indicator flashes, temperature display alternates to show E2 and cabinet temperature.	Buzzer sounds intermittently.
	Condenser sensor fails.	Alarm indicator flashes, temperature display alternates to show E1 and cabinet temperature.	Buzzer sounds intermittently.
	Ambient sensor fails.	Alarm indicator flashes, temperature display alternates to show E0 and cabinet temperature	Buzzer sounds intermittently.
	Heat exchanger sensor fails.	Alarm indicator flashes, temperature display alternates to show E3 and cabinet temperature.	Buzzer sounds intermittently.
Low battery Alarm	Battery capacity runs low or battery switch is not turned on.	During the test, the alarm indicator flashes.	----

Free Manuals Download Website

<http://myh66.com>

<http://usermanuals.us>

<http://www.somanuals.com>

<http://www.4manuals.cc>

<http://www.manual-lib.com>

<http://www.404manual.com>

<http://www.luxmanual.com>

<http://aubethermostatmanual.com>

Golf course search by state

<http://golfingnear.com>

Email search by domain

<http://emailbydomain.com>

Auto manuals search

<http://auto.somanuals.com>

TV manuals search

<http://tv.somanuals.com>