User Manual

HFG2.0 Gas Fuel Metering Valve



SD-6009 Rev. 6
August 2008

PRECISION ENGINE CONTROLS CORPORATION

This manual provides installation, maintenance, and operating instructions for the HFG2.0 Gas Fuel Metering Valve.

Every attempt has been made to provide sufficient information in this manual for the proper operation and preventive maintenance of the valve. Read this manual in its entirety to fully understand the system.

Operating the HFG2.0 Gas Fuel Metering Valve in accordance with instructions herein ensures long term and reliable operation.

If you need additional information, please contact:

Precision Engine Controls Corporation
11661 Sorrento Valley Road
San Diego, California 92121
(858) 792-3217 • (800) 200-4404
Fax: (858) 792-3200
E-mail: peccntl@precisioneng.com

TABLE OF CONTENTS









Purpose of This Guide	iii
Product Identification	iii
What the User Should Know	iv
Related Publications.....	iv
1 INSTALLING THE HFG2.0	1
1.1 Before Beginning.....	1
1.2 General Specification Summary.....	3
1.3 Mechanical Installation.....	4
1.4 Electrical Connections.....	14
2 UNDERSTANDING THE HFG2.0	25
2.1 System Description	25
2.2 Electrical Description.....	26
2.3 Mechanical Description.....	30
2.4 Identification Plate	36
3 OPERATING THE HFG2.0	39
3.1 Powering Up	39
3.2 Finding Home Position.....	39
3.3 Holding Motor Current State	40
3.4 Moving to Stop Position	42
3.5 Controlling Motion	42
3.6 Resetting the Actuator.....	44
3.7 Monitoring System Health.....	45
3.8 Changing Set-Up Parameters	50
4 MAINTAINING THE HFG2.0	53
4.1 Refurbishment	53
5 TROUBLESHOOTING.....	55
5.1 FAULT File.....	59
APPENDIX A: DECOMMISSIONING & DISPOSAL	61
APPENDIX B: GLOSSARY	63

LIST OF FIGURES

Figure 1-1. Typical HFG2.0 Gas Fuel System Installation	5
Figure 1-2. Alternate HFG2.0 Gas Fuel System Installation	5
Figure 1-3. HFG2.0 Dimensions, 3-Piece Housing	8
Figure 1-4. HFG2.0 Dimensions, 1-Piece Housing	9
Figure 1-5. HFG2.0 Mounting Orientations	10
Figure 1-6. HFG2.0 Mounting Provisions, 3-Piece Housing (Standard Mounting)	11
Figure 1-7. HFG2.0 Mounting Provisions, 1-Piece Housing (Standard Mounting)	12
Figure 1-8. HFG2.0 Mounting Provisions, 1-Piece Housing (Reversed Mounting)	13
Figure 1-9. HFG2.0 System Power Wiring Diagram	15
Figure 1-10. Typical Power Connection With Power Supply	15

Figure 1-11. Typical Power Connection With Battery	15
Figure 1-12: HFG2.0 System Signal Wiring Diagram.....	19
Figure 1-13. Typical Analog Input Connection	20
Figure 1-14. Typical Analog Output Connection	20
Figure 1-15. Typical Discrete Input Command Connection	20
Figure 1-16. Typical Discrete Output Alarm Connections	21
Figure 1-17. Typical RS232 Serial Interface Connection	21
Figure 2-1. HFG2.0 Electronics System Block Diagram	28
Figure 2-2. HFG2.0 Cut-Away View – Actuator Main Housing Assembly.....	34
Figure 2-3. HFG2.0 Cut-Away View (Partial).....	35
Figure 2-4. Typical Identification Plate.....	36
Figure 2-5. Typical Refurbishment Plate	37
Figure 3-1. HFG2.0 Basic Operation Flow Chart.....	41
Figure 3-2. HFG2.0 Actuator Position vs. DEMAND	43
Figure 3-3. Dead Band of Actuator, Position vs. DEMAND Curve	44

LIST OF TABLES

Table 1-1. Wire List for HFG2.0 Power Harness	14
Table 1-2. Power Supply Requirements.....	16
Table 1-3. Wire Size for HFG2.0 Power Harness.....	17
Table 1-4. Wire List for HFG2.0 System Signal Harness.....	18
Table 1-5. Computer COM Port Pin Outs	22
Table 1-6. Wire Size for HFG2.0 Signal Harness	23
Table 3-1. Default Configuration For FAULT Alarm 	47
Table 3-2. Default Configuration For OVERTEMP Alarm 	47
Table 3-3. Fault Configuration For FAULT Alarm   	48
Table 3-4. Fault Configuration For OVERTEMP Alarm   	49
Table 3-5. Typical HFG2.0 Setup Parameters With Default Values	51
Table 5-1. Initial Installation Troubleshooting Chart.....	57
Table 5-2. HFG2.0 In-Service Troubleshooting Chart.....	57
Table 5-3. HFG2.0 Electrical Continuity Troubleshooting Chart.....	58

Purpose of This Guide

This publication is designed to help the user install, operate, maintain and troubleshoot the HFG2.0 Gas Fuel Metering Valve.

Product Identification

Most of the information in this manual is applicable to all generations of the product. Where unique information applies to a specific generation, one of the following symbols will be shown to indicate as such:

-  Fourth generation (isolated RS-232)
P/Ns: 5002605-XXX, 5002610-XXX, 5002447-XXX **or:**
Any Remanufactured Part with Config 116 and above
Configuration: 116 and above
Firmware version: 3.00 and above

-  Third generation (isolated RS-232)
P/Ns: 5002605-XXX, 5002610-XXX, 5002447-XXX **or:**
Any Remanufactured Part with Config 109 and DP 1028
Any Remanufactured Part with Config 110 and above
Configuration: 110 and above
Firmware version: 2.02 and above

-  Second generation (non-isolated RS-232)
P/Ns: 5002605-XXX, 5002610-XXX, 5002447-XXX
Configuration: between 105 and 108
Firmware versions: 2.0, 2.1

-  First generation (non-isolated RS-232)
P/Ns: 50024XX-XXX
Configuration: earlier than 105
Firmware versions: 1.00, 1.01

What the User Should Know

To install, operate and troubleshoot the HFG2.0, it is necessary for the user to have a fundamental understanding of:

- Electronics concepts, such as voltage, current, and switches
- Mechanical motion control concepts, such as inertia, torque, velocity, distance, force

Related Publications

- ActWiz Software Operations Manual (p/n SD-6010)

1 INSTALLING THE HFG2.0

1.1 Before Beginning

Inspection

The HFG2.0 should be inspected immediately after unpacking. Check for dings or dents or any other obvious signs of damage. Remove the protective caps from the connectors and check for any bent pins or damage to the threads of the connectors. Examine the wires of the signal and power harnesses for any signs of damage to the wire insulation.

In the event that any damage is detected, contact PECC for instructions about how to proceed.



Note: Retain the actuator's original shipping container. In the event of future transportation requirements, this container will minimize any damage during shipment.

Recommended Installation Process

Users must determine if it is best to couple the HFG2.0 to the load before or after the installation has been tested.

- Review the general specifications
- Mechanically connect the clevis of the HFG2.0
- Mechanically mount the valve body of the HFG2.0
- Mechanically connect the input pipe of the HFG2.0
- Mechanically connect the output pipe of the HFG2.0
- Connect Case Ground of the HFG2.0 to System Ground
- Connect the 4-wire Power Harness of the HFG2.0 to the user's power supply or battery
- Connect the 17-wire Signal Harness of the HFG2.0 to the user's controller
- Test the installation

Electrical Noise Guidelines

PECC has taken the following measures to reduce electrical noise with the HFG2.0:

- High-voltage wires are routed separately from low-level signals through the use of separate power and signal harnesses.

An additional measure to reduce electrical noise is to:

- Ensure that the HFG2.0 is properly grounded, as per Section 1.4 of this manual.

Environmental Considerations

The HFG2.0 operates satisfactorily with ambient air temperature of -40 °C (-40 °F) to +93 °C (+200 °F), and is designed as an explosion-proof assembly. The HFG2.0 enclosure is Canadian Standards Association (CSA) Type 3, European IP65.



CAUTION

Solvent/water may enter the electronics area during a high-pressure wash, which can cause decreased performance or failure of the unit.

1.2 General Specification Summary

PARAMETER	VALUE
Power Input	
Voltage Range	80-160 VDC; 120 VDC nominal
Maximum Current	20 A
Typical Transient Current	+20A < 60ms; +10A < 120ms; -5A < 100ms
Typical Continuous Current	< 1A
Inputs and Outputs	
Discrete Inputs RUN and RESET commands	ON Voltage: 12 – 32 VDC, +24 VDC nominal @ 6.5 mA OFF Voltage: 1.0 VDC, maximum
Discrete Outputs FAULT & OVERTEMP alarms	OFF Voltage: 32 VDC maximum @ 150 µA typical Effective ON Resistance 1.1 kΩ, nominal @ ≥ 1.5 VDC:
Analog Input DEMAND command signal	Current: 4 to 20 mA; 25 mA Maximum Voltage: 5 VDC Maximum Internal Impedance: 200 Ω
Analog Outputs POSITION & MTR CURRENT feedback	Current: 4 to 20 mA External Load Resistance: 300 Ω, Maximum
Maximum Common Mode Voltage	±200 VDC User I/O to 120 VDC Return (less serial interface)
Performance	
Maximum Operating Pressure	500 psig
Proof Pressure	2000 psig
Minimum Controllable Flow (Natural Gas)	15 pph (configuration dependent)
Maximum Controllable Flow	30,000 pph (configuration dependent)
Step Response (10% to 90%)	100 ms
Flow Accuracy	± 5% of flow point, typical
Mean Time Before Unscheduled Removal	30,000 Hours
Life Cycles	32,000 Minimum
Environmental	
Temperature, Operating Ambient:	-40° C (-40° F) to +93° C (+200° F)
Temperature, Operating Fuel:	-40° C (-40° F) to +125° C (+257° F)
Temperature, Storage	-40° C (-40° F) to +125° C (+257° F)
Environmental Rating	Rated to CSA Type 3 and European IP65 Sealed against dust, protected against water
EMC	Meets EN 50081-2 and EN50082-2 for DC powered industrial equipment
Vibration	Meets Mil-Std-810E, Category 4 (5 – 2000 Hz)

Certifications North American Certifications European Directive Compliance (CE Mark)	CSA Class I, Div 1, Group B, C, D; T4  II 2G EEx d, IIB+H ₂ ; T4 97/23/EC Pressure Equipment Directive (PED) 94/9/EC Potentially Explosive Atmospheres (ATEX) 02ATEX6051X 98/37/EC Machinery Directive 89/336/EEC Electromagnetic Compatibility Directive (EMC)
Materials Actuator Housing Valve Housing Conduit Union Seals Connectors	6061-T6 Anodized Aluminum 6061-T6 Anodized Aluminum 316 Stainless Steel (Optional) Zinc Plated Steel Viton and Teflon Aluminum
Dimensions	9.7 in x7.7 in x 25.4 in
Weight	100 lbs. Max (Aluminum Valve Housing, 3-piece) 85 lbs. Max (Aluminum Valve Housing, 1-piece) 190 lbs. Max (Stainless Steel Valve Housing, 3 piece)

1.3 Mechanical Installation

This section describes proper HFG2.0 installation. Ensure compliance with the factory recommendations.

Typical Fuel System

The HFG2.0 installs as part of a gas fuel system as shown in Figure 1-1. In this arrangement, the HFG2.0 is located downstream from two normally closed gas shut-off valves.

An alternate arrangement is shown in Figure 1-2. In this installation, the HFG2.0 is located between two normally closed gas shut-off valves.

Fuel Filtering

For efficient valve operation, filter the fuel through a 40-micron absolute filter before it reaches the valve. This extends the time between routine maintenance. Locate the fuel filter as close as possible to the valve INLET.

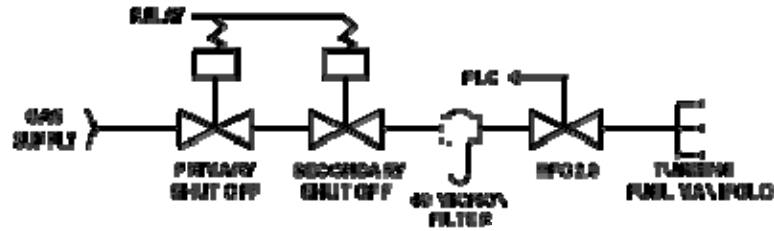

Figure 1-1. Typical HFG2.0 Gas Fuel System Installation

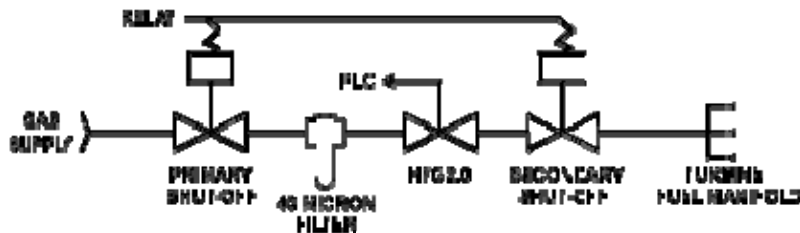

Figure 1-2. Alternate HFG2.0 Gas Fuel System Installation

Dimensions

Figure 1-3 and Figure 1-4 show external dimensions for the 3-piece housing and 1-piece housing versions of the HFG2.0, respectively.

Mounting Considerations

The HFG2.0 can be mounted directly to a gas turbine engine skid using brackets provided by the engine manufacturer. The HFG2.0 can be mounted with any directional orientation, whether horizontal, vertical, or at an angle. The clevis must be supported if the HFG2.0 is mounted horizontally.

Valve life can be maximized if the HFG2.0 is mounted with the vertical orientation shown in Figure 1-3 or Figure 1-4, where the valve end is on the bottom. The drain hole is most effective when mounted in this vertical orientation.

 **Note:** The one-piece housing version of the HFG2.0 does not have a drain hole.

The HFG2.0 includes four (4) 0.50-24 UNC-2B mounting holes with stainless steel heli-coil inserts for securing the valve body. The mounting holes on the standard version of the HFG2.0 are located on the opposite side from the electrical connectors. The mounting holes on the reversed version of the HFG2.0 are located on the same side as the electrical connectors (see Figure 1-5).

Figure 1-6 shows mounting provisions for the 3-piece housing version of the HFG2.0. Figure 1-7 and Figure 1-8 show mounting provisions for the 1-piece housing version of the HFG2.0.



Note: Provide adequate clearance to the OUTLET port to facilitate cleaning.

Lifting Considerations

The aluminum body HFG2.0 weighs approximately 100 lbs. The stainless steel body HFG2.0 weighs approximately 190 lbs. PECC recommends using the 0.375-inch diameter clevis to lift the valve, in conjunction with the appropriate lifting equipment.



Note: The clevis exceeds the Factor of Safety (FOS) requirement of 3, based on component yield strength, per ASME B30.20-1999.



WARNING

Lifting Hazard – Do not attempt to hand-lift the actuator. Use appropriate lifting equipment.

Connecting the Clevis

The clevis can be used to secure the actuator end of the HFG2.0. A high-strength shoulder bolt (0.375" diameter) is recommended to fasten the clevis to a user-provided mount bracket.

The clevis can be rotated to any orientation to support installation. Loosen the four retaining screws and rotate to the desired angle. The screw pattern can be indexed ± 45 degrees to provide additional adjustment. When adjustments are complete, torque the four retaining screws to 117-138 in-lbs.



WARNING

Explosion Hazard – Do not remove the clevis. Removing the clevis violates the warranty.

Care should also be taken when rotating the clevis or indexing the screw pattern to avoid scratching the flame path or introducing particulates to the assembly.

Pipe Connections

The standard pipe connection for the HFG2.0 is per SAE J518, -32 (2 inch), code 61. The valve bodies contain locking helical inserts. Contact Precision Engine Controls for other connection options.



Note: To maintain flow control accuracy, ten-(10) pipe diameters (15 inches) straight length minimum is recommended upstream and downstream.

Flange Bolts

Precision Engine Controls Corporation recommends SAE Grade 5 or better flange bolts. Torque to 650 – 800 in-lb.



CAUTION

Do not over-torque fittings. Over-torque may result in stripped threads and/or helical insert damage.

Drain Plug

PECC recommends 60 – 65 in-lb of torque for the drain plug (see Figure 1-6, View B-B).



Note: The one-piece housing version of the HFG2.0 does not have a drain hole.

Vent Port

The gas leakage rate through the vent port is less than 200 cm³/hr (air or N² as test flow). The vent port features a 1/8-NPT fitting. See Figure 1-4. Consult local installation codes to determine whether and how to connect this port.

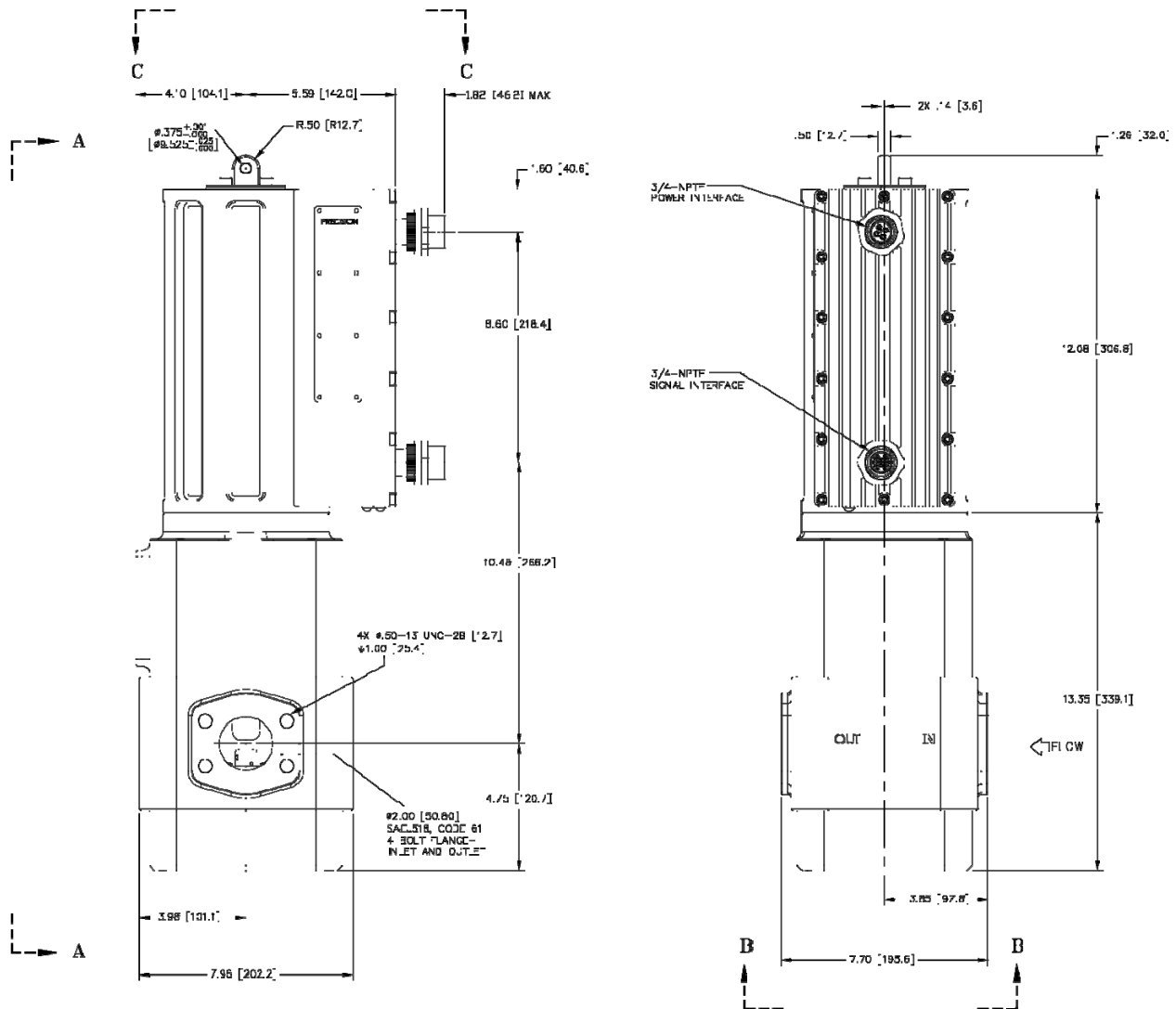
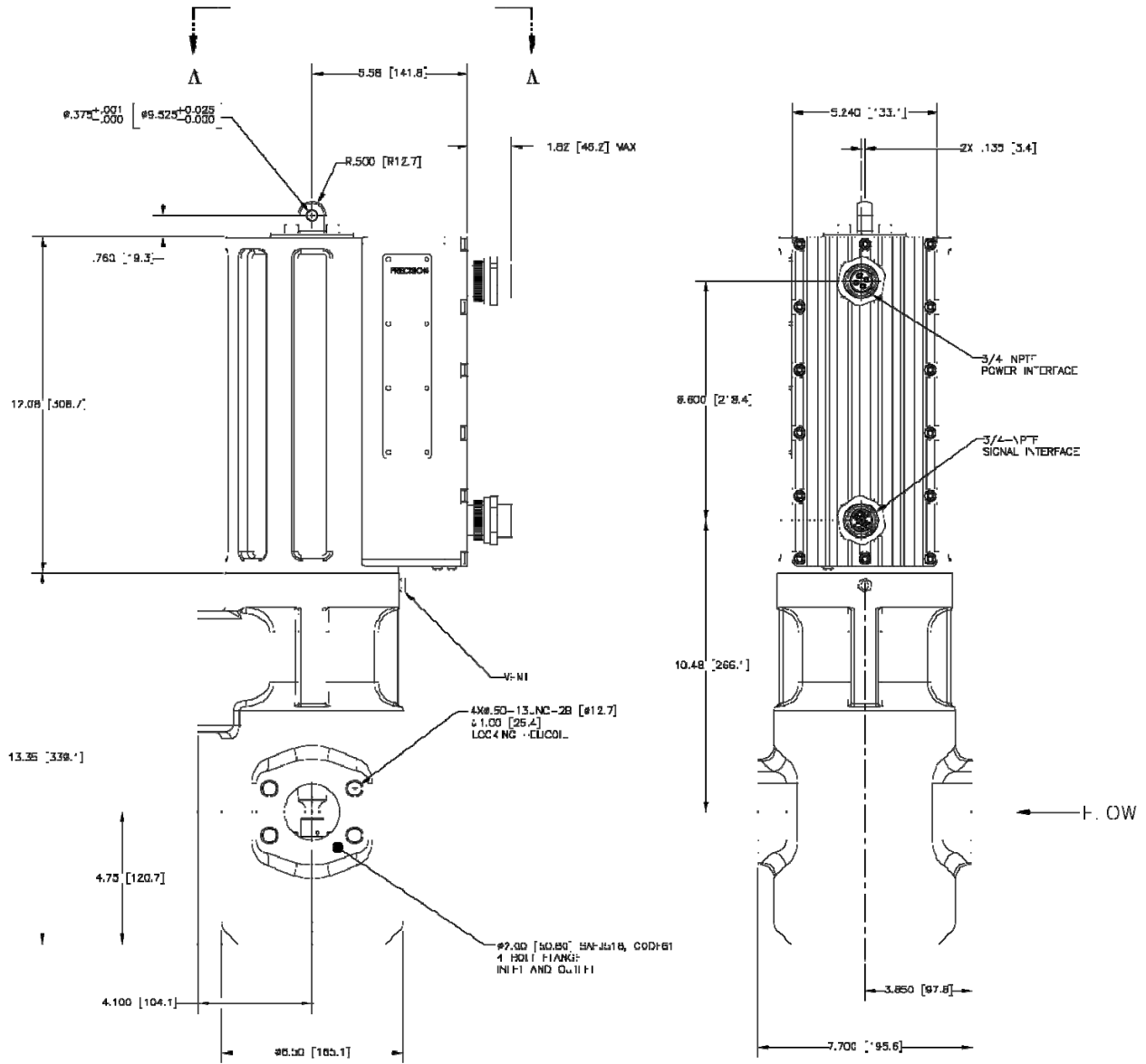

Figure 1-3. HFG2.0 Dimensions, 3-Piece Housing



STANDARD

Figure 1-4. HFG2.0 Dimensions, 1-Piece Housing

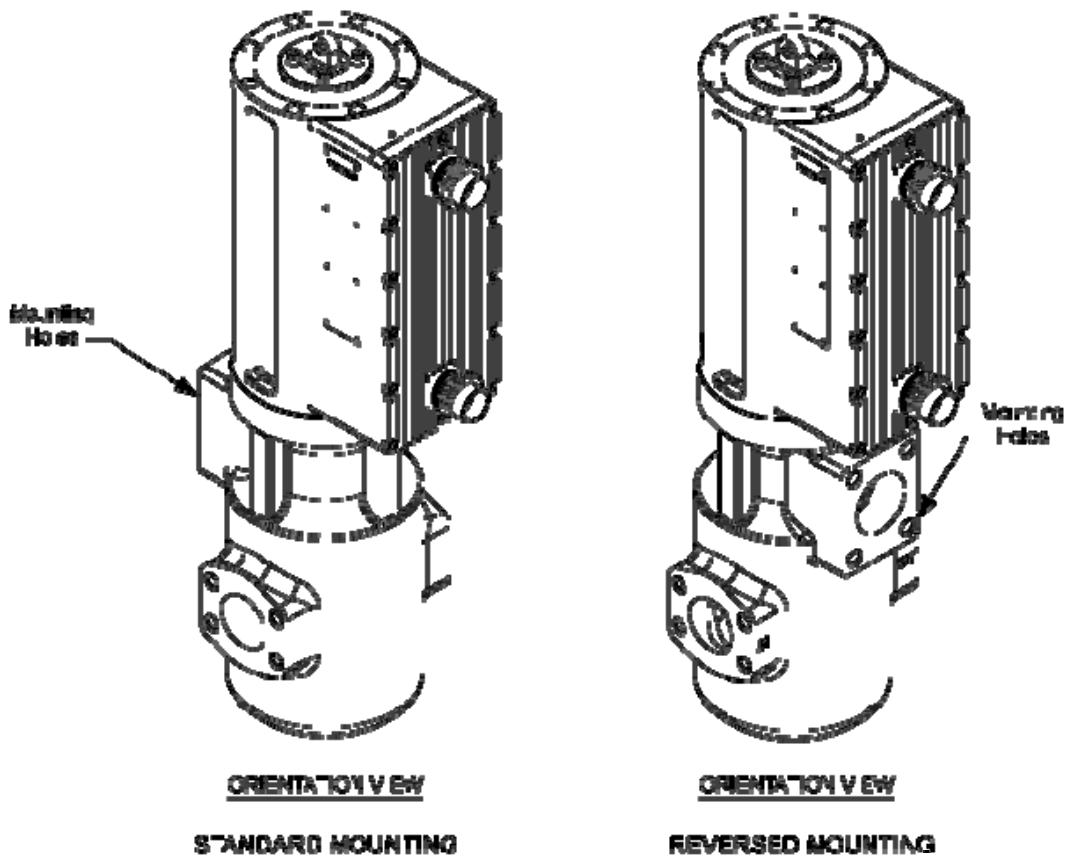

Figure 1-5. HFG2.0 Mounting Orientations

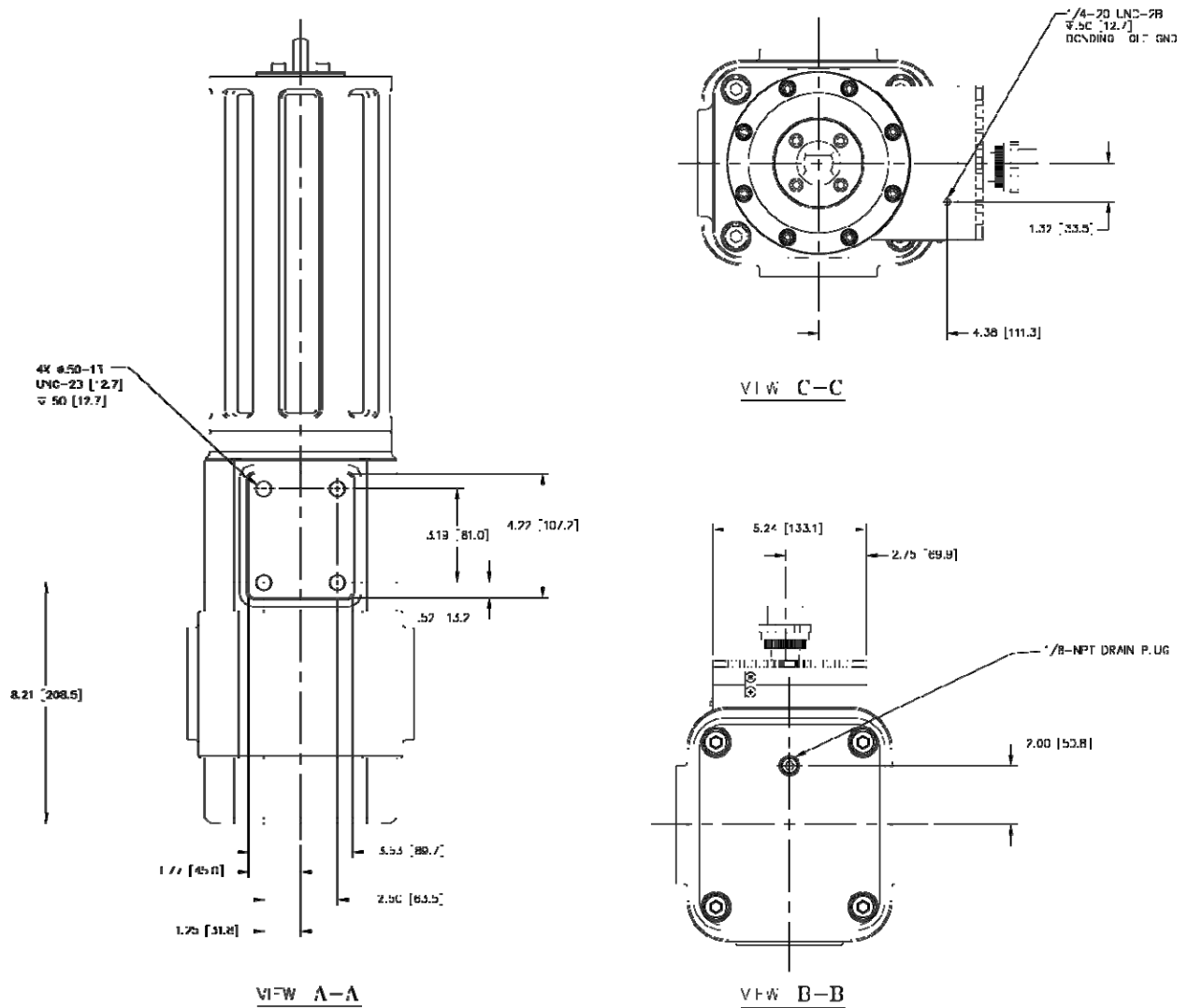

Figure 1-6. HFG2.0 Mounting Provisions, 3-Piece Housing
(Standard Mounting Orientation Shown)

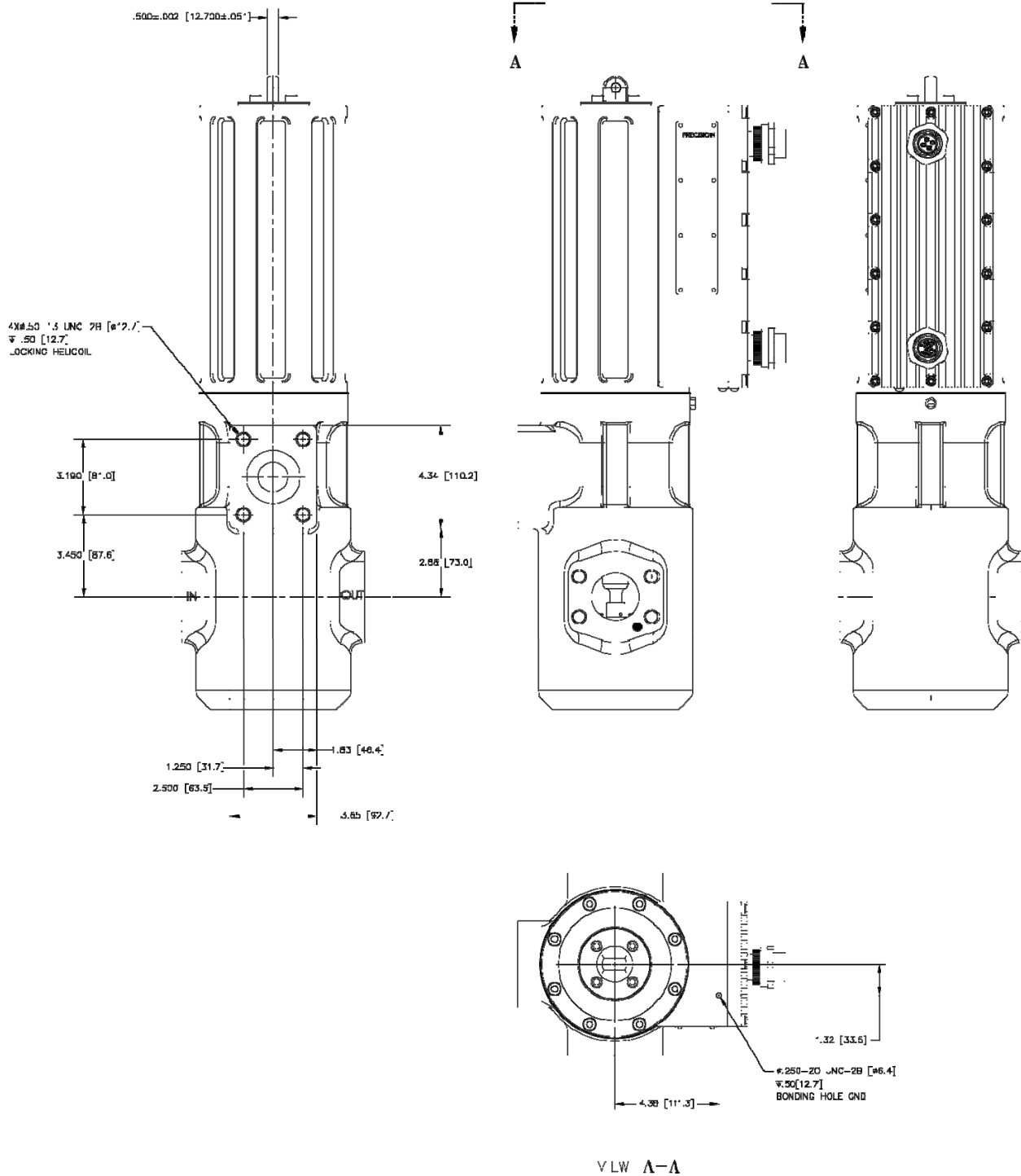

Figure 1-7. HFG2.0 Mounting Provisions, 1-Piece Housing (Standard Mounting Orientation Shown)

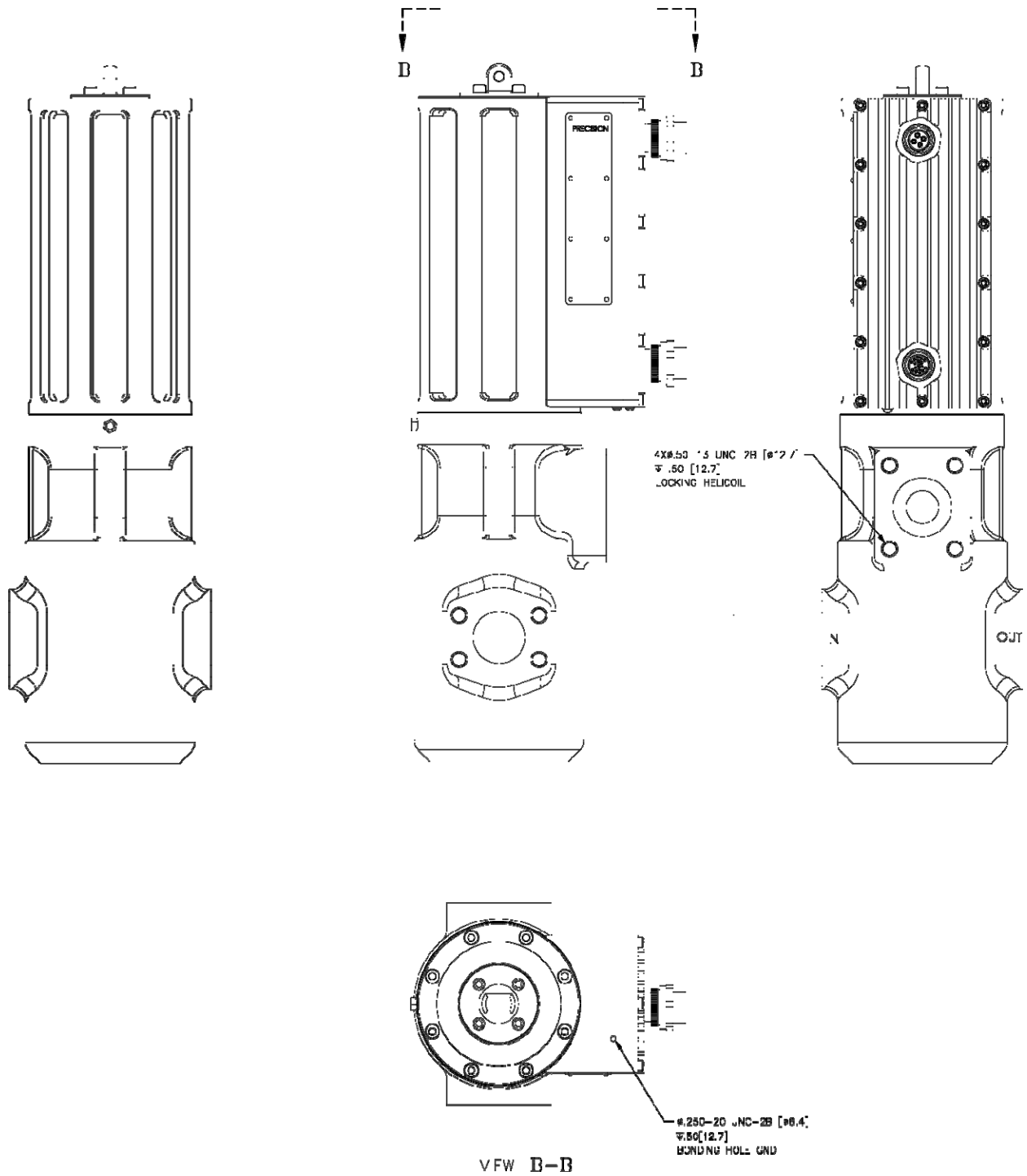

Figure 1-8. HFG2.0 Mounting Provisions, 1-Piece Housing (Reversed Mounting Orientation Shown)

1.4 Electrical Connections

The HFG2.0 is suitable for use in hazardous locations. See the General Specification Summary in Section 1.2 for certifications. Ensure compliance with the factory recommendations, and that wiring is in accordance with local requirements.

**WARNING:****94/9/EC (ATEX) Compliance – Special Conditions for Safe Use:**

Two special factory-sealed unions are mounted on the equipment to ensure the electrical connection to the network and to provide the feedback signal to the user.

The installation of these devices and the final connections to the conduit shall comply with the requirements of the European standards.

Ground Connection

The case of the HFG2.0 features a threaded hole (0.250-20 UNC-2B female thread) that is dedicated for the ground connection. This hole has been left unpainted and uncoated to ensure a good electrical contact. This threaded hole is located on the clevis end of the unit, (see Figure 1-6, Figure 1-7 or Figure 1-8). Use a screw with a 0.250-20 UNC-2A thread to connect the case of the HFG2.0 to the same ground plane as the user's controller.

Power Connections

The HFG2.0 operates on a 120VDC (nominal), user-provided input voltage, which is supplied to the unit through the integral four-wire power harness. See Table 1-1 for the wire list for the HFG2.0 power harness. See Figure 1-9 for the HFG2.0 system power wiring diagram. See Figure 1-10 for a typical power connection with a power supply. See Figure 1-11 for a typical power connection with a battery.

WIRE COLOR	FUNCTION	AWG
RED	Power	14
WHITE/RED	Power (AUX)	14
GREEN	Power Return	14
WHITE/GREEN	Power Return (AUX)	14

Table 1-1. Wire List for HFG2.0 Power Harness

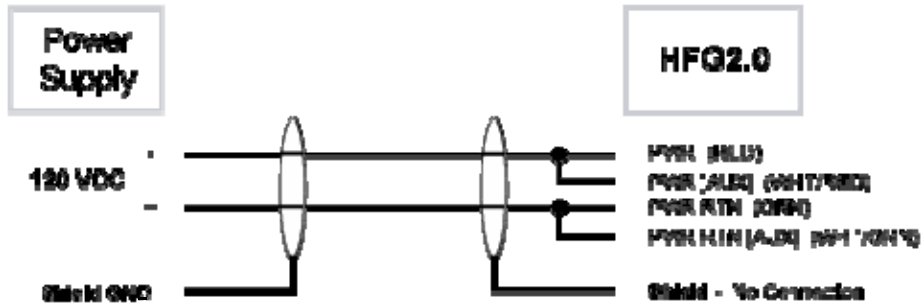

Figure 1-9: HFG2.0 System Power Wiring Diagram

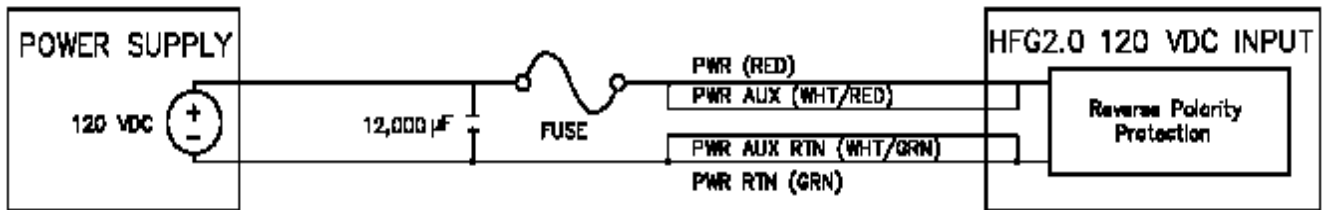

Figure 1-10. Typical Power Connection With Power Supply

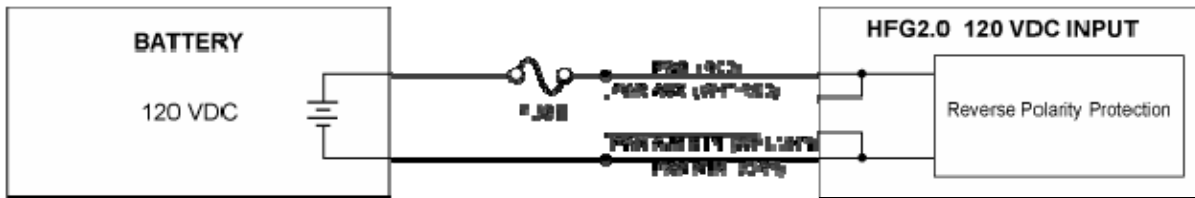

Figure 1-11. Typical Power Connection With Battery



WARNING - Shock Hazard

Connect both the 120 VDC power and auxiliary wires. If only the primary power wires are connected, the 120 VDC auxiliary power wires are electrically live and must be insulated on the ends.

- ✓ **Note:** A battery system is recommended for highest reliability.
- ✓ **Note:** If a 120 VDC power supply is used rather than a battery, ensure an output capacitance of at least 12,000 μ F, which can both sink and source electric current. See Power Supply Requirements (Table 1-2).
- ✓ **Note:** Use a separate conduit for the power wiring. This prevents noise pickup and transmission from ancillary equipment, which could cause instability in the actuator.

Power Supply Requirements

Table 1-2 below lists the power supply requirements for the HFG2.0.

PARAMETER	VALUE
Voltage	
Nominal	120 VDC
Range	80 – 160 VDC
Max. Ripple	4 VAC RMS or 12 VAC p-p
Current	
Maximum	20 Amps
Continuous, Typical	<1 Amp
Transient, Typical	+20 A <60 ms +10 A <600 ms -5 A <100 ms
*Output Capacitance	12,000 μ F (typical)

Table 1-2. Power Supply Requirements

*The output capacitance applies for non-battery power systems and assumes full-stroke step changes in actuator position at rated load. This value is typical. The actual value required is dependent on the user's specific DC power system design, including:

- Power sources used in the DC power system (their output impedance, transient response, rating, diode decoupling [if any], topology, etc.)
- All electrical loads and components connected to each respective power bus branch
- Switching relationships of these electrical loads and components to each other (for example, does a large motor and actuator turn off at about the same time, etc.)
- Bus branch conductor length and arrangement (flat bus bars, round cables, twisted, etc.)

Therefore, it is not possible to correctly state a single capacitance value that should be placed on the bus. It may require no added bus capacitance or hundreds of thousands of microfarads of capacitance. A typical output capacitance value used for non-battery power systems is 50,000uF, but the actual value depends on the specific power system as discussed above.

It is best to test the power system for adequate capacitance by executing full-stroke step changes with the actuator at the same time as all other devices on the bus are switched and measuring the bus voltage at the actuator power input point to verify that it does not dip below the minimum or exceed the maximum bus voltage specifications. This test should be performed at both the minimum and maximum expected operating voltages

Also, the output capacitance should be carefully positioned so that it is never disconnected from the HFG2.0 power input during any contact or switching operations.

Recommended Wiring for System Power

The recommended wire for connecting to system power is a two-conductor shielded cable containing twisted-pair wires with individual shields. Use a wire size large enough to accommodate the installation and provide a maximum one (1) ohm loop resistance. See Table 1-3 (below) for recommended wire sizes.

DISTANCE TO USER POWER	RECOMMENDED WIRE SIZE (Minimum)
≤ 500 ft.	AWG 10, stranded
> 500 ft.	Consult Factory

Table 1-3. Wire Size for HFG2.0 Power Harness



WARNING

Explosion Hazard – Do not connect or disconnect while circuit is live. For US Group B hazardous locations, an explosion proof seal must be placed within 18 inches.

CAUTION

Disconnect all HFG2.0 connections prior to welding.

Signal Connections

Signals are sent between the HFG2.0 and the user's controller through the integral 17-wire signal harness. See Table 1-4 for the wire list for this harness. See Figure 1-12 for the system signal wiring diagram.

WIRE COLOR	FUNCTION	AWG
WHITE/ORANGE/YELLOW	Serial/RX In	20
WHITE/ORANGE/BLUE	Serial/TX Out	20
WHITE/ORANGE/GREEN	Serial RETURN	20
BLACK	OVER TEMP Alarm	20
WHITE/BLACK	OVER TEMP Alarm RETURN	20
ORANGE	FAULT Alarm	20
WHITE/ORANGE	FAULT Alarm RETURN	20
VIOLET	RUN Command	20
WHITE/VIOLET	RUN Command RETURN	20
GRAY	RESET Command	20
WHITE/GRAY	RESET Command RETURN	20
BROWN	Position Demand	20
WHITE/BROWN	Position Demand RETURN	20
YELLOW	Position Feedback	20
WHITE/YELLOW	Position Feedback RETURN	20
BLUE	Motor Current	20
WHITE/BLUE	Motor Current RETURN	20

Table 1-4. Wire List for HFG2.0 System Signal Harness

**Engine
Controller**

HFG2.0

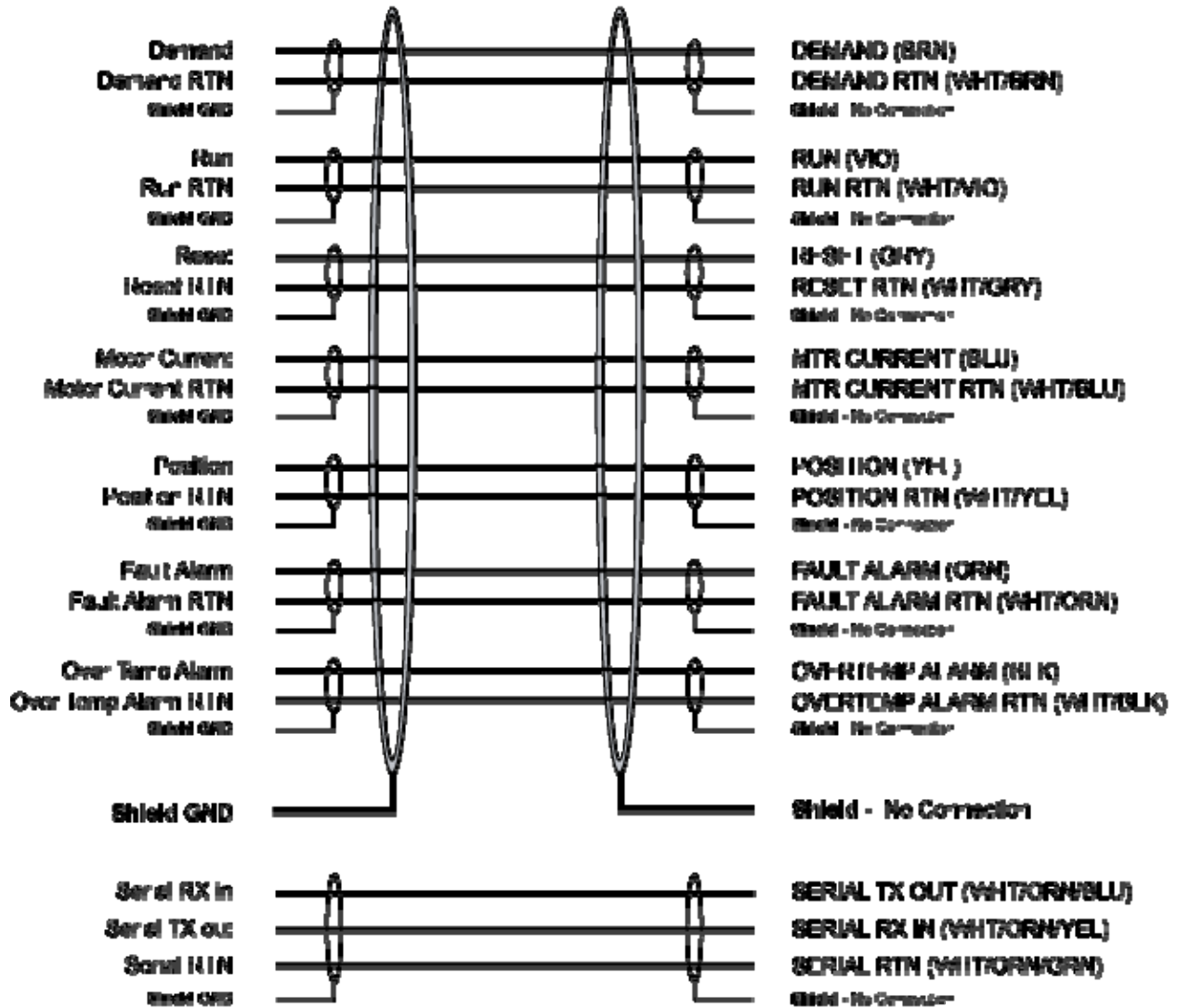

Figure 1-12: HFG2.0 System Signal Wiring Diagram

- Note:** For proper operation of the controller, the voltage between the control inputs and the negative terminal of the power supply should be below 200 VDC.
- Note:** The Serial Return is internally connected to the 120 VDC input Return.

Analog Inputs

The analog input, DEMAND, has a current range of 4 - 20 mA. It is electrically isolated up to 500 VAC from the enclosure, 120 VDC power, digital I/O, and serial interface. The analog interfaces are not isolated from each other. See Figure 1-13 for a typical analog input connection.

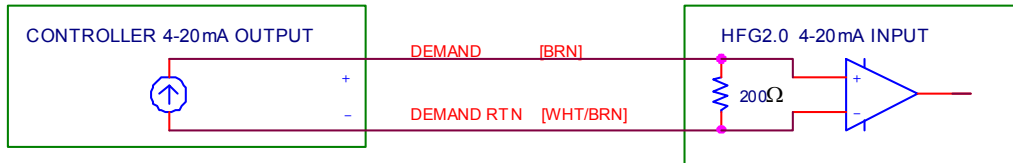

Figure 1-13. Typical Analog Input Connection

Analog Outputs

The analog outputs, MOTOR CURRENT and POSITION, have a current range of 4 - 20 mA. They are electrically isolated up to 500 VAC from the enclosure, 120 VDC power, digital I/O, and serial interface. The analog interfaces are not isolated from each other. See Figure 1-14 for a typical analog output connection.

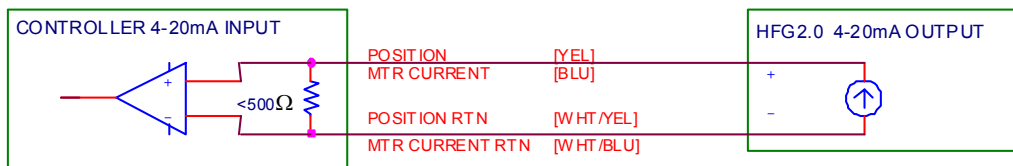

Figure 1-14. Typical Analog Output Connection

Discrete Inputs

The discrete inputs are 24 VDC ON (High) and 0 VDC OFF (Low). They are electrically isolated up to 500 VAC. See Figure 1-15 for a typical discrete input connection.

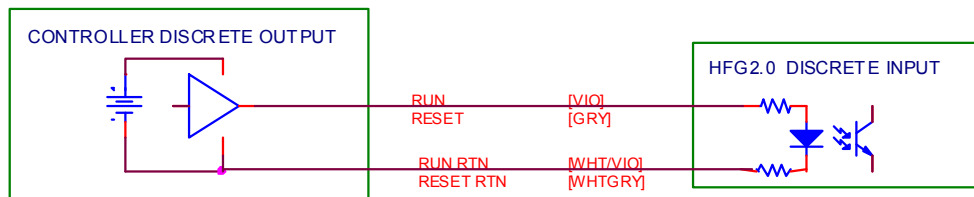

Figure 1-15. Typical Discrete Input Command Connection

Discrete Outputs

The discrete outputs are +24 VDC. They are electrically isolated up to 500 VAC. See Figure 1-16 for a typical discrete output alarm connection.

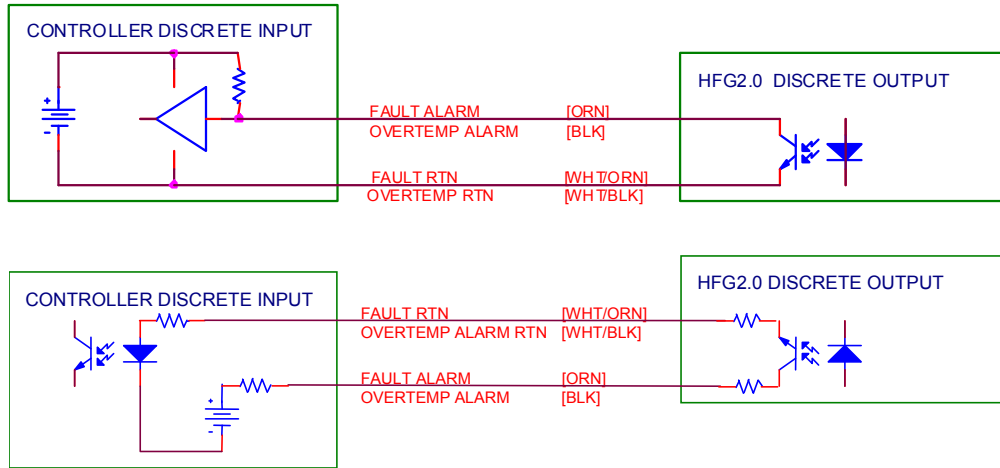

Figure 1-16. Typical Discrete Output Alarm Connections

RS232 Serial Communications Interface

Signal levels for the serial communications input and output are per RS232 standards. See Figure 1-17 for a typical RS232 serial interface connection. See Table 1-5 for computer COM port pin-outs for RS232.

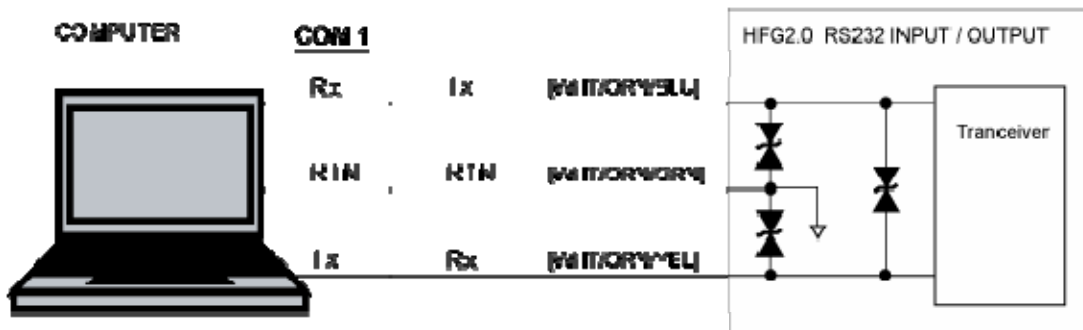



Figure 1-17. Typical RS232 Serial Interface Connection

FUNCTION	Standard 9-Pin COM Port	Standard 25-Pin COM Port
Transmit (Tx).	Pin 3	Pin 2
Receive (Rx)	Pin 2	Pin 3
Ground (GND)	Pin 5	Pin 7

Table 1-5. Computer COM Port Pin Outs

**WARNING**



Property Damage Hazard – The serial inputs are not electrically isolated . Failure to properly isolate the user serial interface could result in actuator or computer damage. Use separate conduits for power and signal wiring. Close proximity to power lines may cause signal interference.

Shock Hazard – The serial inputs are not electrically isolated . If the power input is floating (not grounded), the serial input connections may have up to 120 VDC present.

Property Damage Hazard – DO NOT connect 24 VDC power to any of the serial interface connections.

 **Note:** The pin designations shown in Table 1-5 are for the COM port on the **computer**. Make sure that the wiring to the COM port mating connector correctly matches Transmit from the HFG2.0 to Receive on the computer's COM port, and vice versa.

 **Note:** The maximum distance for serial connections is 50 ft. This will typically only allow for local interface with a laptop PC.

 **Note:** The serial interface connections are not isolated . Isolation must be provided when connecting to a computer.

Recommended Wiring for System Signals

The recommended wiring is a 17-conductor shielded cable containing twisted-pair wires with individual shields. Use a wire size large enough to accommodate the installation and provide a maximum fifty (50) ohm loop resistance. See Table 1-6 for recommended wire sizes.

DISTANCE TO USER'S CONTROLLER	RECOMMENDED WIRE SIZE (Minimum)
≤ 1000 ft.	AWG 18, stranded
> 1000 ft.	Consult Factory

Table 1-6. Wire Size for HFG2.0 Signal Harness

 **Note:** Use a separate conduit for the signal wiring. This prevents noise pickup and transmission from ancillary equipment, which could cause instability in the actuator. If conduit is not used, signal wires should be at least 4-6 inches from any other wires.

Ensure that all shielded cables are twisted conductor pairs with either a foil or braided shield. PECC recommends Belden 8719 shielded twisted-pair audio, broadcast and instrumentation cable. All signal lines should be shielded to prevent picking up stray signals. Connect shields as shown in Figure 1-12. Wire exposed beyond the shield should be as short as possible.



CAUTION

This valve is 89/339/EEC EMC Directive compliant (CE mark) using watertight, flexible conduit (plastic over steel) and Belden 8719 shielded, twisted pair-audio, broadcast and instrumentation cable. Use of other conduit or wire invalidates EMC Directive compliance.

Do not connect 24 VDC power without current limiting (25 mA) across digital or analog outputs.



INTENTIONALLY BLANK

2 UNDERSTANDING THE HFG2.0

2.1 System Description

The HFG2.0 is an electrically operated gas fuel-metering valve that requires only 120 VDC power, an analog fuel demand signal, and a discrete RUN command to achieve basic operational capability. No pneumatic or hydraulic power is required.

The HFG2.0 is a closed loop servo system containing Motor Control Electronics (MCE), a brushless DC-motor-driven ball screw actuator and valve flow body assembly. The valve closes its own control loop on a position feedback signal from an internal resolver. Thus, the valve continuously modulates its position and provides precise fuel metering.

Gas fuel enters the valve flow body assembly INLET port. The fuel flow is evenly split via a contamination deflector and pressure-balanced orifice assembly as it enters the INLET port chamber. The orifice assembly contains a set of poppets and control orifices. As the valve actuator retracts, the poppet assembly exposes fuel from the INLET port chamber to the two orifices. The fuel flows through in the annulus between each poppet and fixed orifice and recombines in the OUTLET port chamber. The fuel exits through the OUTLET port.

Flow is metered between the poppets and control orifices in proportion to the poppet position and resultant flow area. The flow area ranges from zero with a Demand signal at 0 % of its range to maximum with a Demand signal at 100% of its range. The orifices contain pressure-energized soft seats and metal-to-metal hard seats, which provide a leak-tight seal when the poppets are in a closed position.

A pre-loaded, fail-safe spring is located between the valve housing and poppet assembly. The spring load increases as the valve opens. If a power failure occurs, the spring causes the poppets to return to the soft seats, thereby closing the valve.



WARNING



The soft seats are unidirectional and will leak if the OUTLET is more than 50 psi greater than the INLET. PECC recommends that the INLET port pressure always be \geq to the OUTLET port pressure.

2.2 Electrical Description

The electric actuator in the HFG2.0 incorporates digital motor control electronics (MCE). The MCE contain analog to digital converters, a digital signal processor (DSP), application specific integrated circuit (ASIC) and power supplies. Figure 2-1 shows the system block diagram.

The MCE provides the interface for the user's engine control system and power supply. The MCE incorporates analog and discrete inputs and outputs, and a serial interface. The MCE provides signal conditioning for all external analog and discrete I/O, as well as internal resolver and thermistor inputs.



Note: The MCE analog and discrete signal interfaces are electrically isolated. The serial communication interface is optically isolated  

The MCE internally interfaces with the brushless DC motor, resolver and thermistors. The MCE performs all necessary commutation, control and status monitoring for the HFG2.0.

Power

The HFG2.0 operates on an input voltage of 120 VDC (nominal) that is provided by the user via an integral four-wire power harness. Refer to Figure 1-10 or 1-11 for a typical connection. Refer to the General Specification Summary Table in Section 1.2 for load specification values.

Control Signals

The HFG2.0 accepts three two-wire external control signals via the integral 17-wire signal harness. Refer to Figures 1-13 and 1-15 for typical connections. Refer to the General Specification Summary Table in Section 1.2 for signal specification values.

RUN Command

The user-provided RUN command is a discrete input. The RUN command must be ON to enable the HFG2.0 to perform the homing sequence after resetting or powering up. The RUN command also enables the HFG2.0 to track the DEMAND signal. The valve will move to the Stop Position if the RUN command is set to OFF or lost.

RESET Command

The RESET command is a user-provided discrete input to the HFG2.0. This command causes the HFG2.0 to reset all internal position indicators, reload all set-up parameters, and to then move the valve through its initial homing sequence again. (The RUN command must be set to ON before the homing sequence can begin.) RUN and DEMAND inputs are ignored

during the RESET command. To reset the HFG2.0, +24 VDC must be applied across the RESET wires for at least 0.5 seconds in order to reset the controller and actuator.

DEMAND Signal

The DEMAND signal is a user-provided analog input that is used to control the position of the valve. The current level of the DEMAND signal is correlated to the position of the valve within its range. The minimum Demand signal of 4.0 mA is correlated to the CLOSED (Home) position. The maximum Demand signal of 20 mA is correlated to the OPEN (maximum flow) position.

Feedback Signals

The HFG2.0 provides two two-wire feedback signals via the integral 17-wire signal harness. Refer to Figure 1-14 for typical connections. Refer to the General Specification Summary Table in Section 1.2 for feedback specification values.

Position Feedback

The HFG2.0 provides analog valve position feedback to the user. This internally-generated feedback signal is proportional to the valve position. A signal level of 4 mA represents that the valve is at its CLOSED (Home) position; while a signal level of 20 mA represents that the valve is at its maximum span.

Motor Current Feedback

The HFG2.0 provides motor current feedback. This internally-generated feedback signal is proportional to actuator load. A signal level of 4 mA represents no load on the actuator; while a signal level of 20 mA is the maximum load.

HFG2.0

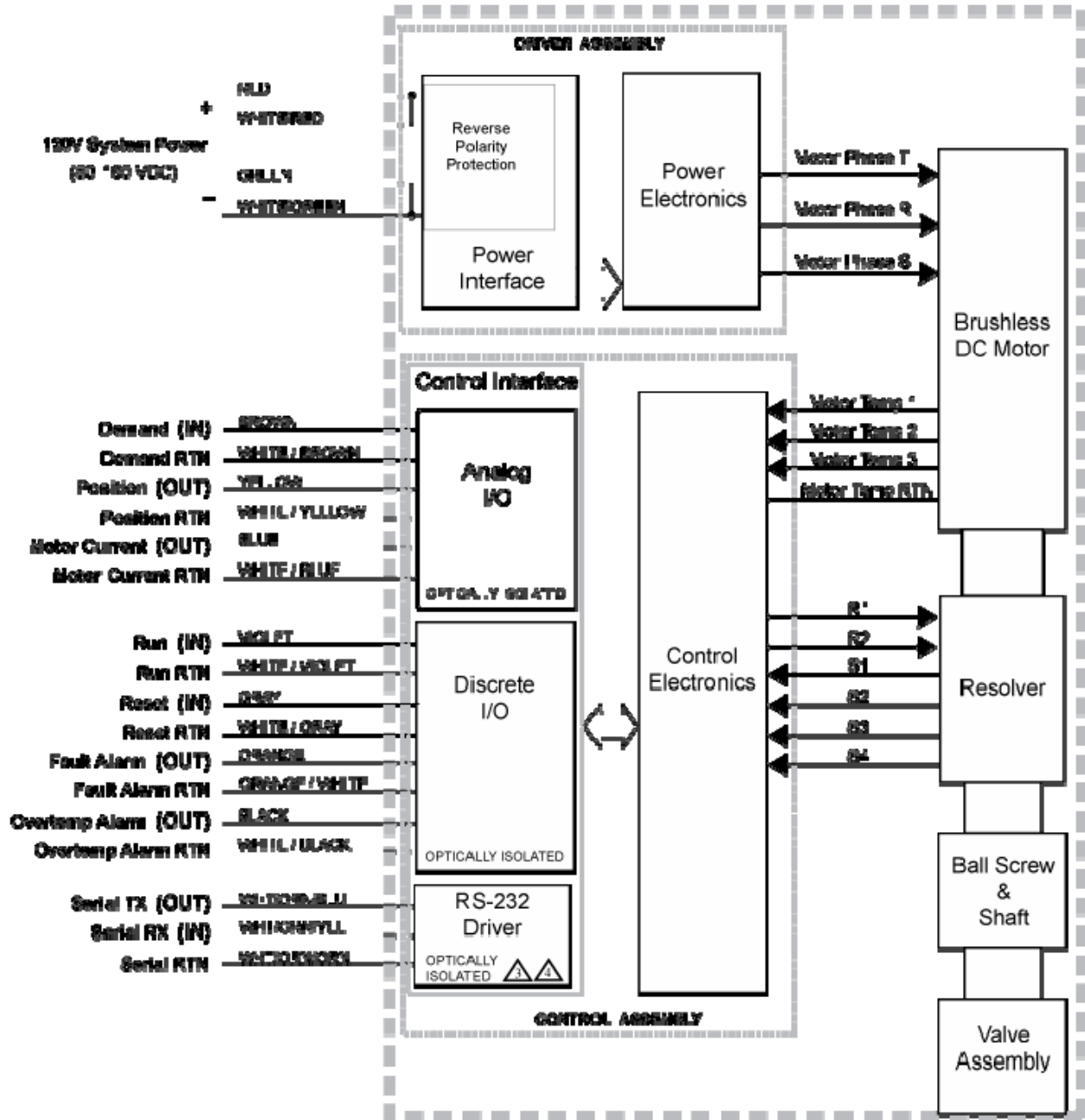





Figure 2-1. HFG2.0 Electronics System Block Diagram

Alarms



The HFG2.0 provides two two-wire alarm signals via the integral 17-wire signal harness. The discrete alarm outputs are solid-state switches which are normally closed. The user's controller provides +24 VDC to complete the circuit. Refer to Figure 1-16 for typical connections. Refer to the General Specification Summary Table in Section 1.2 for alarm specification values. See Section 3.7 for additional details about alarms.













FAULT Alarm

The fault configuration for the FAULT alarm is programmable in the most recent generation  of the HFG2.0 (factory-configurable only). If a fault condition occurs, the FAULT alarm switch will open, interrupting the circuit with the user's controller. See Table 3-1 for the default configuration .

See Table 3-3 for a list of fault conditions represented by the FAULT alarm in earlier generations    of the HFG2.0.

OVERTEMP Alarm



The fault configuration for the OVERTEMP alarm is programmable in the most recent generation  of the HFG2.0 (factory-configurable only). If a fault condition occurs, the OVERTEMP alarm switch will open, interrupting the circuit with the user's controller. The default configuration for the OVERTEMP alarm is Motor OVERTEMP, where the circuit will open if the temperature in two or more of the motor winding exceeds 135°C. See Table 3-2 for details about the default configuration .

In earlier generations of the HFG2.0, the OVERTEMP alarm is dedicated to Motor Over Temp    and Electronics Over Temp   faults. If the HFG2.0 detects that the temperature in two or more of the motor windings exceeds 130° C    or the electronics temperature exceeds 110° C   the OVERTEMP circuit will open (see Table 3-4). In generation , the Electronics Over Temp fault is assigned to the FAULT alarm. If the electronics temperature exceeds 110° C  the FAULT circuit will open (see Table 3-3).

RS232 Communications

The HFG2.0 allows for RS232 serial communication through three wires in the integral 17-wire signal harness. The RS232 wires, Rx IN, Serial Tx OUT and Serial RTN, are used to communicate with a user-provided computer. Serial communication can be used to change the HFG2.0 set-up parameters and to retrieve fault diagnostics. Contact Precision Engine Controls Corporation to request fault diagnostic software. See Section 3.8 for additional details about set-up parameters.



Note: The MCE analog and discrete signal interfaces are electrically isolated. The serial communication interface is optically isolated  

2.3 Mechanical Description

The HFG2.0 consists of two main parts, an actuator and a valve assembly.

Actuator

The actuator is the primary drive mechanism for the valve assembly. The actuator portion of the HFG2.0 consists of four main assemblies:

- Main Housing Assembly
- Brushless DC Motor Assembly
- Resolver Assembly
- Linear Drive Mechanism

Main Housing Assembly

The main housing assembly consists of the main housing, motor cover, extension-rod bearing, and associated seals. The main housing assembly is the primary structural system component and supports all the bearings, motor cover, mountings, and connectors. It also provides explosion-proof containment.

The housing is fitted with a stainless steel liner to provide thermal and dimensional stability for the main bearing. This liner is permanently installed into the aluminum main housing. A retaining ring is included for redundant retention.

The main housing also contains rigid mechanical stops to prevent extension rod travel beyond the design specification. See Figure 2-2.

Brushless DC Motor Assembly

A brushless DC motor powers the HFG2.0 linear drive mechanism. The DC motor consists of a stator and rotor. See Figure 2-2.

Motor Stator

The motor stator is attached to the main housing by a pre-loaded wave spring and screws. Thermistors are embedded in the stator windings to

monitor winding temperatures. The motor electrical power and thermistor wires pass through a conduit into the electronics housing.

Motor Rotor

The motor rotor is locked to the ball screw shaft via a straight key. The motor rotor contains powerful magnets that align with the energized stator windings, thereby creating torque and shaft rotation.

Resolver Assembly

A brushless, non-contacting resolver is the primary HFG2.0 feedback sensor. Resolver excitation is achieved via a sinusoidal signal from the MCE. The resolver provides two sinusoidal feedback signals back to the MCE. The resolver assembly includes a stator and rotor. See Figure 2-2.

Resolver Stator

The resolver stator is clamped to the main housing between the main bearing retaining nut and resolver retainer. The angular position of the resolver stator relative to the resolver rotor is adjustable. Electrical wires from the resolver are reeled in the resolver adapter to allow rotation. The resolver wires, along with the motor and thermistor leads, pass through a conduit into the electronics housing.

Resolver Rotor

The resolver rotor is mounted to the ball screw shaft by a key. As the rotor rotates, the stator transformer output signals provide shaft rotation information to the MCE.

Linear Drive Mechanism

The Linear Drive Mechanism converts the rotary motion of the Motor Assembly to linear actuator motion. The core of the mechanical drive system is the linear ball screw drive containing a screw shaft, ball-bearing-fitted nut, extension rod and main duplex thrust bearings. See Figure 2-2.

Screw Shaft

The thrust bearings, motor rotor, motor end bearing, and resolver rotor are mounted directly to the screw shaft. A ball-bearing track is machined into the screw shaft.

Ball Nut

As the screw shaft rotates, the ball nut translates the rotary motion into linear motion along the shaft axis. The direction of movement along the shaft axis is determined by direction of rotation.

Extension Rod and Bearings

The extension rod is threaded on the ball nut. As the ball nut translates, the extension rod moves in and out of the HFG2.0 main housing. Counter-clockwise (CCW) rotation (facing the motor end of the actuator) of the motor rotor and screw shaft results in the extension rod extending out of the main housing. Clockwise (CW) rotation results in the extension rod retracting back into the main housing.

The extension rod support bearing is provided for lateral support. Thrust and radial loads are transferred from the extension rod through the ball nut to the main preloaded duplex thrust bearings. The thrust bearings transfer the loads to the main housing by the main bearing and shaft retaining nuts.

A motor end bearing is provided for additional radial shaft stability. The resolver rotor, motor rotor, motor bearing, and spacers are all stacked on the ball screw shaft and retained by a single nut. This arrangement prevents actuator axial loads from passing through the resolver rotor and motor rotor.

The end of the extension rod is connected to the poppet assembly of the valve. The linear motion of the extension rod, both extension and retraction, is directly translated to the poppet assembly.

Valve

The valve portion of the HFG2.0 consists of four main components:

- Valve Housing Assembly
- Orifice Assembly
- Soft Seats
- Return Spring

Valve Housing Assembly

The valve housing assembly may be either three pieces or one piece.

The three-piece version consists of upper, center, and lower valve body sub-assemblies, which are bolted together with eight, ½" diameter, high-strength, steel bolts. The assembly is made of either machined aluminum or stainless steel.

The one-piece version consists of a cast aluminum main pressure vessel and valve cover assembly. The cover assembly attaches to the bottom of the vessel. This version does not have a drain port.

See Figure 2-3.

Orifice Assembly

The orifice assembly contains a set of poppets and orifice plates. Fuel flow is metered between the INLET port chamber and OUTLET port chamber in proportion to the poppet position and resultant flow area.

The poppet assembly is connected to the extension rod of the actuator. As the actuator retracts, the poppet assembly retracts to increase the flow area between the poppets and the two orifices. As the actuator extends, the poppet assembly extends to reduce the fuel exposure from the INLET port chambers to the two orifices. When the actuator is fully extended, the poppets seat in the orifices to close the valve. See Figure 2-3.

Soft Seats

The orifices contain pressure-energized soft seats and metal-to-metal hard seats, which provide a leak-tight seal when the poppets are in a closed position. See Figure 2-3.

Return Spring

A pre-loaded, fail-safe spring is located between the valve housing and poppet assembly. The spring load increases as the valve opens. If a power failure occurs, the spring causes the poppets to return to the soft seats, thereby closing the valve. See Figure 2-3.

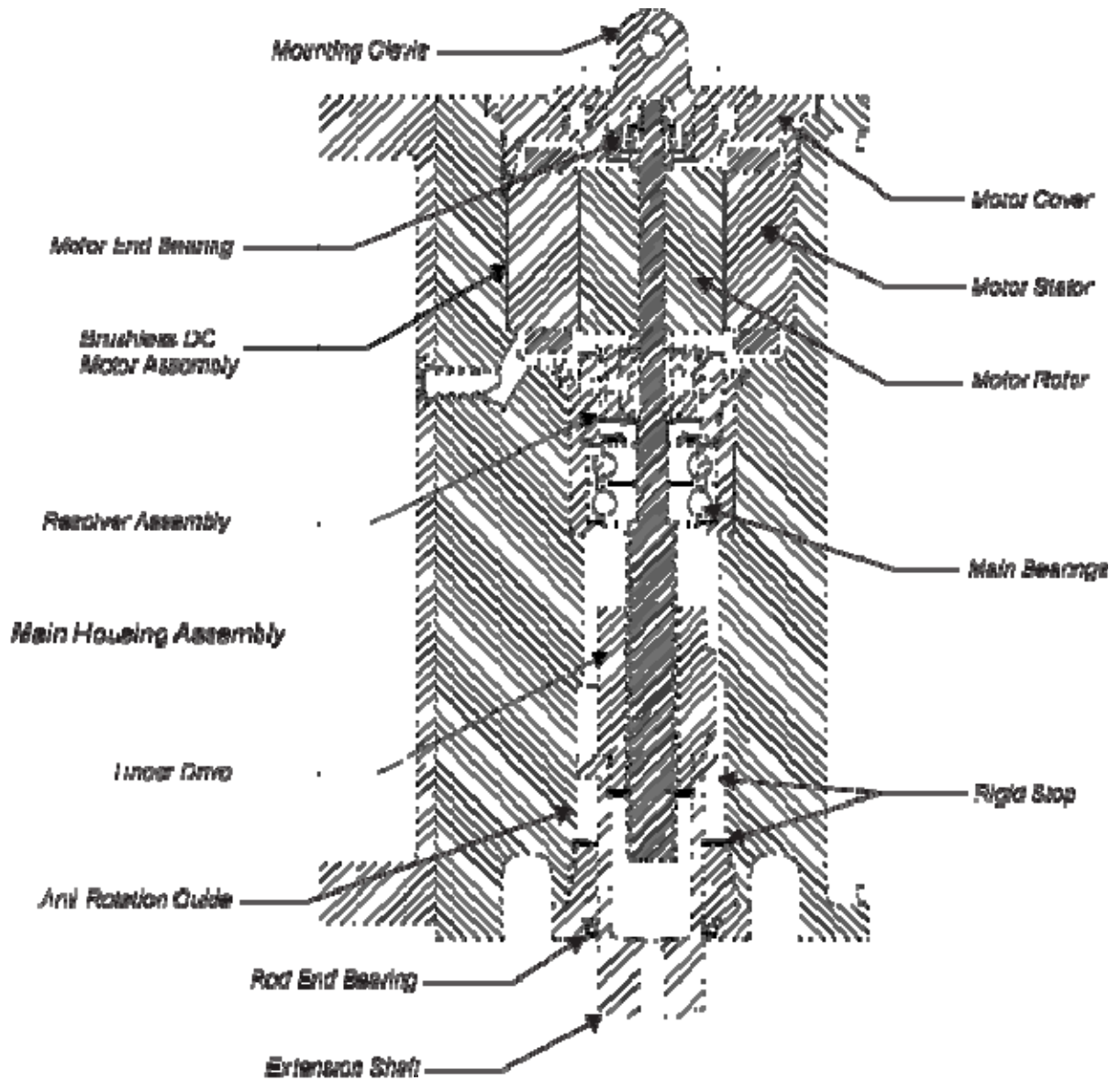

Figure 2-2. HFG2.0 Cut-Away View – Actuator Main Housing Assembly

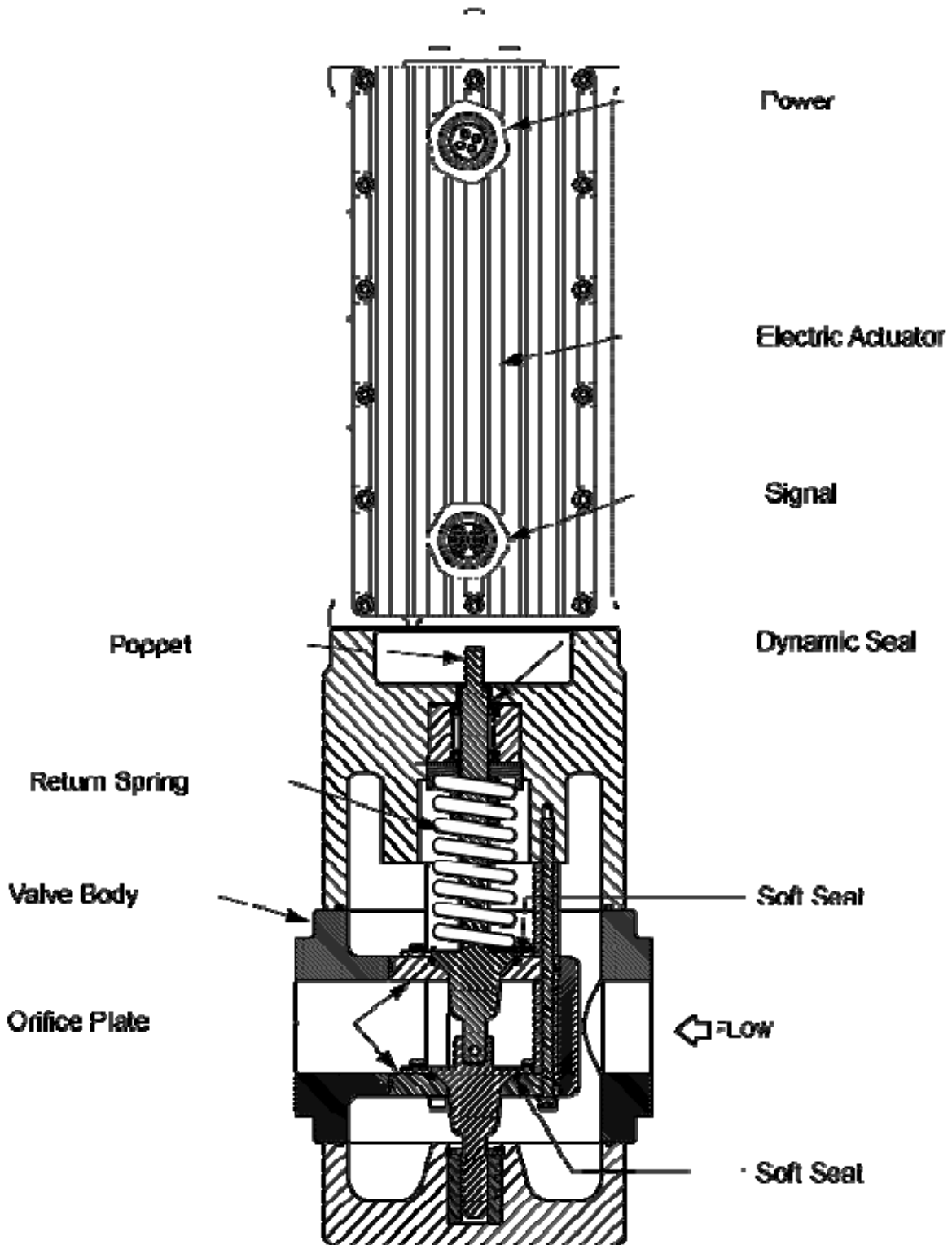
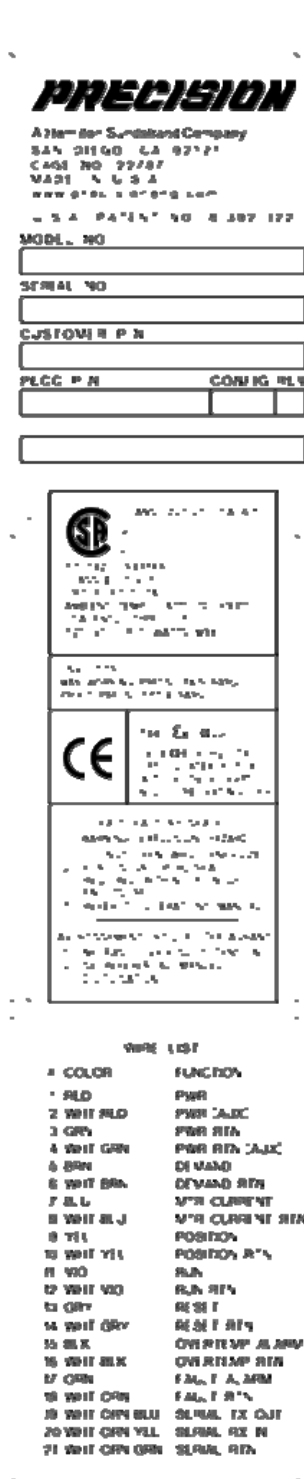

Figure 2-3. HFG2.0 Cut-Away View (Partial)

2.4 Identification Plate



A product identification plate is attached to the HFG2.0 housing assembly. Figure 2-4 shows a typical identification plate.

The identification plate lists model designation, product part number, revision and unit serial number. Hazardous area operation, certification and electrical wiring interface information is also provided.

When a unit is refurbished by PECC, a product refurbishment plate is also attached to the HFG2.0 housing assembly. Figure 2-5 shows a typical refurbishment plate.

The refurbishment plate lists the original manufacture date, refurbishment date, refurbishment kit number, and product revision number.

Figure 2-4. Typical Identification Plate

MANUFACTURE DATE		
<input type="text"/>		
REFURB DATE	REFURB KIT NO.	REV
<input type="text"/>	<input type="text"/>	<input type="text"/>
<input type="text"/>	<input type="text"/>	<input type="text"/>
<input type="text"/>	<input type="text"/>	<input type="text"/>
<input type="text"/>	<input type="text"/>	<input type="text"/>

Figure 2-5. Typical Refurbishment Plate



INTENTIONALLY BLANK

3 OPERATING THE HFG2.0

This section refers to the position of the actuator when describing operation of the HFG2.0 valve. The end of the actuator extension rod is connected to the poppet assembly of the valve. The linear motion of the actuator, both extension and retraction, is directly translated to the poppet assembly. The position of the actuator correlates directly to the position of the valve poppets relative to the orifices. The Home position of the actuator is the CLOSED position (zero position) of the valve.

3.1 Powering Up

When 120 VDC is applied, the firmware program in the HFG2.0 will clear all system registers, retrieve all necessary operating parameters from the electrically erasable programmable read only memory (EEPROM), and perform an internal status check. This will also happen after a RESET command has been received. See the flow chart in Figure 3-1 for an overview of this process.

 **Note:** If the HFG2.0 receives a SET-UP command from the ActWiz software via the RS232 interface after these steps, the system will transition to the Set-Up state. This state allows the user to change the Set-Up parameters and to download the fault file. See Section 3.8 for details.



CAUTION

Always remove the RUN command during power up. If a RUN command is given during the Set-Up parameter download phase of power-up, the valve will not respond until the download is complete and the Home position has been established.

3.2 Finding Home Position

When the program is complete with a status check, it waits for the RUN command.

When the status check and other steps in the Power-Up/Reset process are complete, the HFG2.0 will wait until it receives the RUN command. At

this point, the HFG2.0 has no information about the position of the actuator extension shaft.

When the HFG2.0 receives the RUN command, it will initiate motion in the homing direction. The default homing direction for the HFG2.0 is "Extend". This means that the first movement after Power Up or Reset will be an extension of the actuator in the HFG2.0. The actuator will extend at the rate specified by the Homing Velocity in the Set Up parameters (default is 0.5 in/sec) until a mechanical stop is encountered. In the HFG2.0, this stop is reached when the poppets seat in the orifices, thus closing the valve. The HFG2.0 recognizes that a mechanical stop has been reached when the actuator velocity drops to 0.05 in/sec or less.

The HFG2.0 will then slowly increase the motor current until the current level corresponding to the Maximum Homing Force has been applied. This Maximum Homing Force is also specified in the Set Up parameters and has a default value of 500 lbf. When the pre-determined motor current limit is reached, the HFG2.0 defines this valve position as Home. Home is "Valve Closed" for the HFG2.0. The system will then transition to the Holding Motor Current State. See the flow chart in Figure 3-1 for an overview of this process.

The DEMAND current determines subsequent positioning of the actuator, and thus the valve, within its span once the Home position has been established.

See Section 3.8 for additional information about Set-Up parameters.

3.3 Holding Motor Current State

In the Holding Motor Current state, the actuator applies a constant Holding Force. This feature allows the Home position to thermally expand or contract without damaging the HFG2.0. This Holding Force is specified in the Set Up parameters and has a default value of 500 lbf.

The system is in the Holding Motor Current state immediately after Homing. The system will also move into this state when the DEMAND signal is $> 2\text{mA}$ and $< 4.1\text{mA}$. See the flow chart in Figure 3-1.

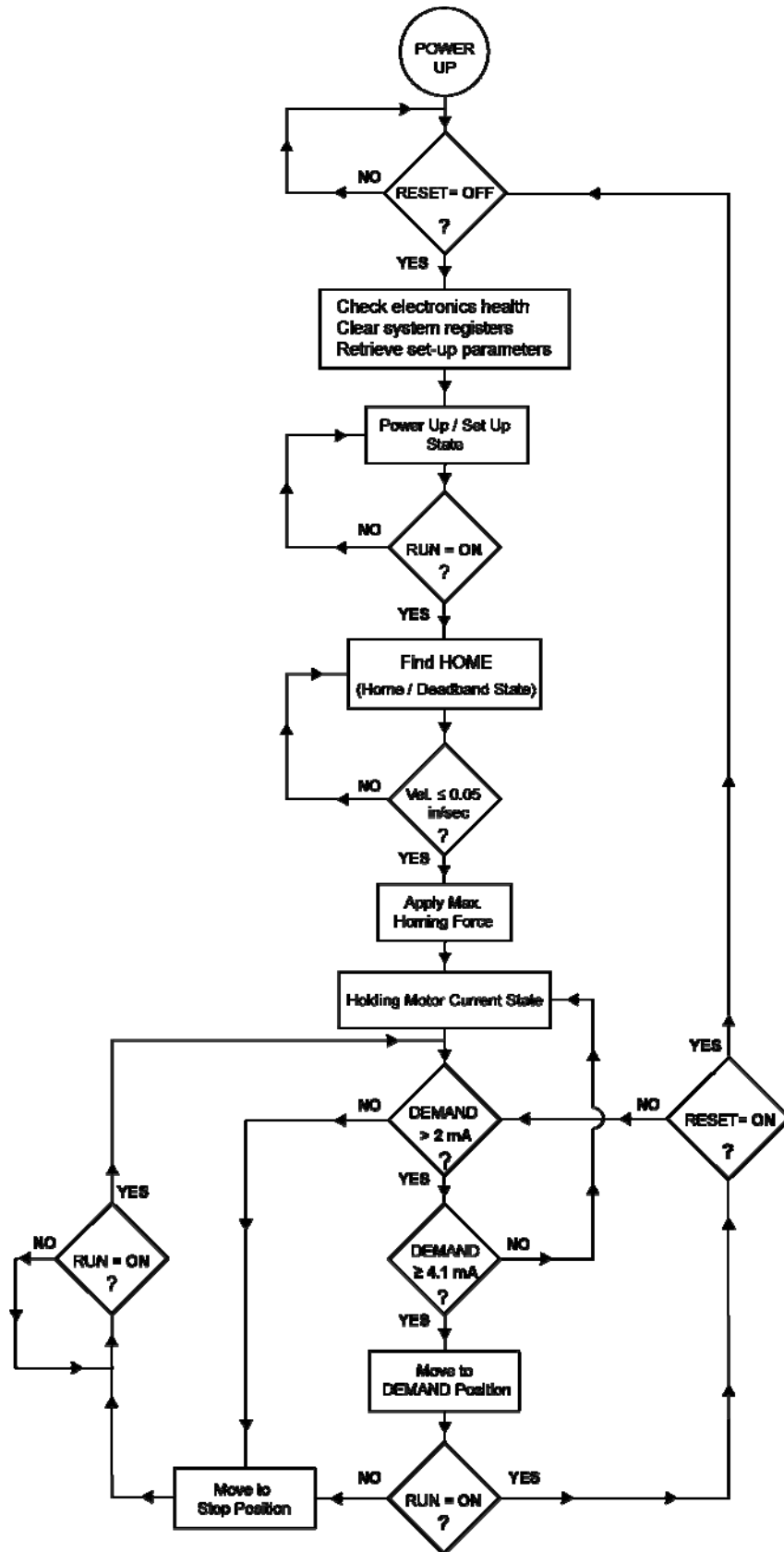

Figure 3-1. HFG2.0 Basic Operation Flow Chart

3.4 Moving to Stop Position

The Stop position is a fail-safe position that may be set anywhere between Home (zero position, Valve Closed) and maximum span (maximum flow). The default value for Stop position is 0.0 inches, as defined in the Set-Up parameters.

The actuator will move to the Stop position if the DEMAND signal is ≤ 2 mA (signal loss) at any time after the actuator has completed Homing. It will also move to the Stop position if the RUN command is removed during any of the running modes. See the flow chart in Figure 3-1.

3.5 Controlling Motion

Once the Home position has been established, the DEMAND current determines subsequent positioning of the actuator, and thus the valve, within its span. The valve will track the DEMAND signal as long as DEMAND ≥ 4.1 mA and RUN is ON, and will apply up to the maximum force to reach this DEMAND position. See Figure 3-2. This is defined as the RUN state, and it is the normal operating mode for the HFG2.0.

The actuator firmware program will remain in this state as long as the demand is greater than 4.1 mA.



Note: If RUN command is removed or position DEMAND ≤ 2 mA, the actuator will go to the STOP position.

Home Position

The Home position correlates to a DEMAND signal of 4 mA. The Home position is determined after Power Up or after the HFG2.0 has been reset.

Dead Band

While the Home position correlates to a DEMAND signal of 4 mA, the actuator will only move for DEMAND signals ≥ 4.1 mA. The DEMAND signal range between 4.0 mA and 4.1 mA is therefore considered a Dead Band. See Figure 3-3.

Once a DEMAND signal ≥ 4.1 mA is detected, the actuator will move to the position that correlates to that current level. See *Interpolation of DEMAND Signal* below.

Hysteresis Band

The actuator should return to the Home position when the DEMAND Signal drops below the 4.1 mA Dead Band threshold. In practice, hysteresis may result in the actuator not returning to Home position until the DEMAND signal drops below a threshold as low as 4.08 mA. The DEMAND signal range between 4.08 mA and 4.1 mA is therefore considered the Hysteresis Band. See Figure 3-3.

Full Span Position (Maximum Flow)

The Full Span (Maximum Flow) position correlates to a DEMAND signal of 20 mA. The maximum Span possible for the HFG2.0 is 1.0 inches due to the configuration of the valve assembly. The maximum Span possible for the actuator used in the HFG2.0 is 2.0 inches due to its mechanical configuration.

The Span value in the Set-Up parameters has a default setting of 1.0 inches of retraction to allow for the distance between the mechanical stop in the valve and the mechanical stop in the actuator. (The default definition of Home is Extend, so default Span is a retraction.)

Interpolation of DEMAND Signal

Linear interpolation of the DEMAND signal in the range between 4 mA and 20 mA is the default condition, as specified in the Set-Up parameters. With linear interpolation, a DEMAND signal of 12 mA (midway in range of DEMAND signal) will correlate to a position at 0.5 inches (midway in the 1.0 inch span). See Figure 3-2 for an illustration of linear interpolation.

 **Note:** The actuator and valve position is linear relative to the DEMAND signal in the default condition. However, due to the physical profile of the poppets, orifices and soft seats, the resultant flow area will NOT be linear relative to the DEMAND signal.

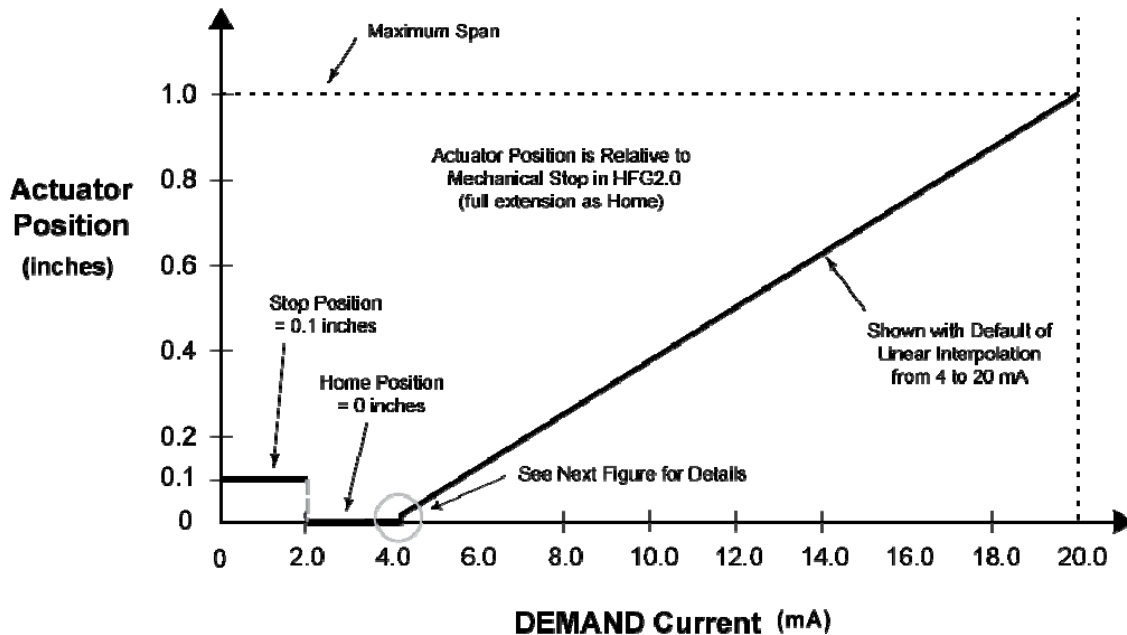

Figure 3-2. HFG2.0 Actuator Position vs. DEMAND, with default conditions Home as a Mech. Stop in HFG2.0

A non-linear interpolation table can be created to define positioning at 16 discrete current levels in the DEMAND signal range, but only during Set Up using the ActWiz Software. See the Section 3.8 for additional details about Set Up parameters.

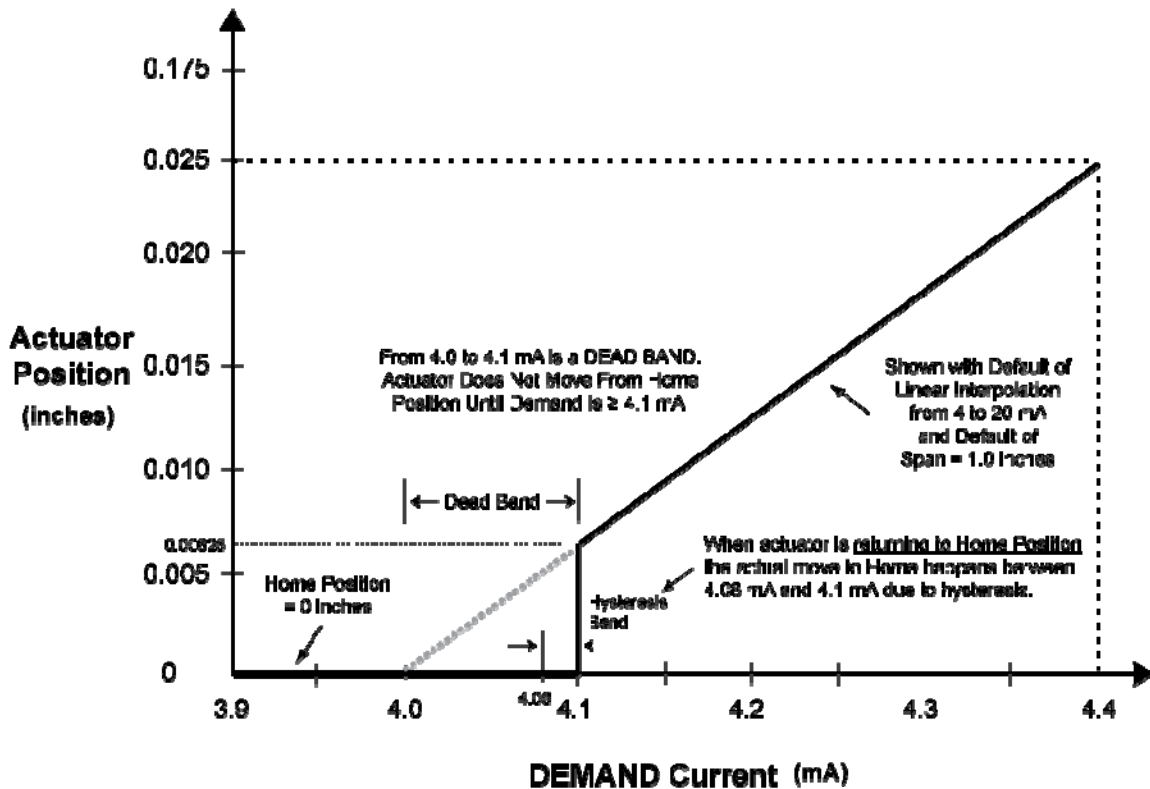

Figure 3-3. Dead Band of Actuator, Position vs. DEMAND Curve

3.6 Resetting the Actuator

To reset the HFG2.0, +24 VDC must be applied across the RESET wires for at least 0.5 seconds. The leading edge of the RESET command causes the HFG2.0 to stop all other operations, but the actual resetting of the HFG2.0 does not begin until RESET is returned to its OFF state. The RESET command causes the HFG2.0 to reset all internal position indicators, reload all Set-Up parameters, and check the health of the electronics. See the flow chart in Figure 3-1 for an illustration of this. The HFG2.0 is now in the Power Up / Reset state.

Once the RUN command is detected as ON, the actuator will then move through its initial homing sequence again. RUN and DEMAND inputs are ignored during the RESET command.

If FAULT alarm is detected, toggling the RESET command will clear the FAULT alarm, but it will NOT clear the fault file.

3.7 Monitoring System Health

The firmware program continuously monitors system health while the HFG2.0 is powered. If any of the health parameters are out of the normal operating range, the MCE outputs a discrete fault alarm to the user's controller.

Some fault causes are:

- MCE over-current
- Tracking error
- RDC failure
- Input voltage out of range



Fault Alarms

The HFG2.0 features two discrete, non-latching outputs that are configured as fault alarms. Upon power-up, the fault circuits close and stay closed in the normal operating condition. When the HFG2.0 detects a system fault, it opens the fault circuit designated for that particular fault.

If a fault alarm is detected, the user should shut down the HFG2.0 to investigate the failure cause. Removing 120 VDC power shuts down the HFG2.0 valve.



toggling the RESET command will clear the alarms.



FAULT Alarm

The configuration of faults assigned to the FAULT alarm is programmable in the most recent generation  of the HFG2.0 (factory-configurable only). See Table 3-1 for the default configuration  of faults assigned to the FAULT alarm.

See Table 3-3 for a list of fault conditions represented by the FAULT alarm in earlier generations    of the HFG2.0.

OVERTEMP Alarm

The configuration of faults assigned to the OVERTEMP alarm is programmable in the most recent generation  of the HFG2.0 (factory-configurable only). In the default configuration, the Motor Over Temp fault is the only fault assigned to the OVERTEMP alarm. If the HFG2.0 detects that the temperature in two or more of the motor windings is 135° C or higher, the OVERTEMP alarm circuit opens. See Table 3-2 for details about the default configuration  of the OVERTEMP alarm.

See Table 3-4 for a list of Over Temp conditions represented by the OVERTEMP alarm in earlier generations    of the HFG.

Fault File

The HFG2.0 firmware also captures the fault data in the EEPROM. If the HFG2.0 is operational, a fault file can be downloaded using ActWiz software via the RS232 interface. The fault file will provide fault information and possible causes. The HFG2.0 must be in the Power Up / Set Up state to download the fault file. See Section 3.8 for details about the Power Up / Set Up state. Contact Precision Engine Controls Corporation to request ActWiz software.

Toggling the RESET command will clear the fault alarm, but it does NOT clear the fault file.

See Section 5: Troubleshooting for a more detailed list of fault causes.



Note: The fault file only records the programmable faults that have been enabled .

Fault Type	Low Alarm	High Alarm	Fault Enable	Persist Time	Auto Reset	Output
Driver Overcurrent	N/A	1000 lbf	Yes	10 Sec	Yes	Yes
Tracking Error	N/A	3.33 %	Yes	10 Sec	Yes	Yes
Position Demand	3.5 mA	20.5 mA	No	1 Sec	No	No
RDC Failure	N/A	N/A	Yes	N/A	No	Yes
+14 Volts	12.0 Volts	16.0 Volts	Yes	7.5 Sec	Yes	Yes
-14 Volts	-16.0 Volts	-12.0 Volts	Yes	7.5 Sec	Yes	Yes
Input Voltage	75.0 Volts	180.0 Volts	Yes	7.5 Sec	Yes	Yes
EEPROM Checksum	N/A	N/A	Yes	N/A	No	Yes
Motor High Temp	N/A	130° C	No	10 Sec	No	No
Electronics High Temp	N/A	110° C	Yes	10 Sec	Yes	Yes
+5 Volts	4.5 Volts	5.5 Volts	Yes	7.5 Sec	Yes	Yes
Watchdog Expired	N/A	N/A	Yes	N/A	No	Yes
EEPROM Write	N/A	N/A	Yes	N/A	No	Yes

Table 3-1. Default Configuration For FAULT Alarm 

Fault Type	Low Alarm	High Alarm	Fault Enable	Persist Time	Shut-Down	Output
Driver Overcurrent	N/A	1000 lbf	No	10 Sec	No	No
Tracking Error	N/A	3.33 %	No	10 Sec	No	No
Position Demand	2 mA	22 mA	No	1 Sec	No	No
RDC Failure	N/A	N/A	No	N/A	No	No
+14 Volts	12.0 Volts	16.0 Volts	No	7.5 Sec	No	No
-14 Volts	-16.0 Volts	-12.0 Volts	No	7.5 Sec	No	No
Input Voltage	75.0 Volts	180.0 Volts	No	7.5 Sec	No	No
EEPROM Checksum	N/A	N/A	No	7.5 Sec	No	No
Motor High Temp	N/A	135° C	Yes	10 Sec	Yes	Yes
Electronics High Temp	N/A	110° C	No	10 Sec	No	No
+5 Volts	4.0 Volts	6.0 Volts	No	7.5 Sec	No	No
Watchdog Expired	N/A	N/A	No	N/A	No	No
EEPROM Write	N/A	N/A	No	N/A	No	No

Table 3-2. Default Configuration For OVERTEMP Alarm 



















































Fault Alarm Type	Persist Time	Fault Action
Driver Over Current	10 Sec   1 Sec 	Driver current \geq Max Force equivalent current, Fault.  Driver current \geq Max Force equivalent current, Fault. If persists for 1 Min., Shutdown  Driver current $>$ 18 Amps, Fault. If persists for 1 Min., Shutdown 
Tracking Error	10 Sec   	If in RUN state, not in home dead band and position error $>$ allowable, Fault.   If not in overcurrent, RDC not faulted and feedback not equal to demand, Fault. 
Watchdog Expired	$<$ 1 Sec	If last reset was caused by watchdog timer timeout or illegal address attempt, Fault.
RDC Failure	$<$ 1 Sec	Tests hardware for RDC failure, sets Fault if RDC failure bit set.
Retract/Extended Command	N/A	Fault not used.
Unregulated Voltage Low	10 Sec	Unregulated voltage low, Fault.
+14 Volts Low	7.5 Sec   $<$ 1 Sec 	+14 V supply $<$ 12 V, Fault.   
+14 Volts High	7.5 Sec   $<$ 1 Sec 	+14 V supply $>$ 16 V, Fault.   
-14 Volts Low	7.5 Sec   $<$ 1 Sec 	-14 V supply $>$ -12 V, Fault.   
-14 Volts High	7.5 Sec   $<$ 1 Sec 	-14 V supply $<$ -16 V, Fault.   
Input Voltage Low	7.5 Sec   $<$ 1 Sec 	Input Voltage $<$ 75 V, Fault.   
Input Voltage High	7.5 Sec   $<$ 1 Sec 	Input Voltage $>$ 180 V, Fault.   
DSP Failure	N/A	Fault not implemented.
Electronics Over Temp	10 Sec 	Electronics temp \geq 110 °C, Fault 

Table 3-3. Fault Configuration For FAULT Alarm   























Fault Type	Persist Time	Fault Action
Motor	10 Sec   1 Sec 	Motor temp $\geq 130^{\circ}\text{C}$, Fault.   . If fault exists and Motor temp $\geq 135^{\circ}\text{C}$ for 10 Sec, shutdown.   Motor temp $> 130^{\circ}\text{C}$, Fault.  . If fault exists and Motor temp $> 130^{\circ}\text{C}$ for 60 Sec, shutdown. 
Electronics	10 Sec  1 Sec 	Electronics temp $\geq 110^{\circ}\text{C}$, Fault.  If fault exists and Electronics temp $\geq 115^{\circ}\text{C}$ for 10 Sec, shutdown.  Electronics temp $> 110^{\circ}\text{C}$, Fault.  If fault exists and Electronics temp $> 100^{\circ}\text{C}$ for 15 Sec, shutdown. 

Table 3-4. Fault Configuration For OVERTEMP Alarm   

Automatic Shutdown Feature







The HFG2.0 has a self-protective shutdown feature. The HFG2.0 will shutdown if:

- Any two motor winding temperatures exceed 135°C for ten (10) seconds    or more (130°C for 60 seconds )
- The electronics temperature exceeds 115°C for 10 seconds  or more (100°C for 15 seconds )

 **Note:** The POSITION and MOTOR CURRENT feedback signals will both be set to 0 mA when the current to the actuator motor is removed.



WARNING

Property Damage and Injury Hazard – If the motor windings exceed 135°C    (130°C ) or the electronics exceed 115°C  (100°C ) , the MCE will shut down power to the motor and electronics thereby allowing the actuator to move with load. When power is removed, the return spring causes the poppets to return to the soft seats, thereby closing the valve. Touching the HFG2.0 may result in serious burn injury

3.8 Changing Set-Up Parameters

The HFG2.0 uses a number of variables to define its functionality. These variables are called Set-Up parameters and they are stored in the EEPROM in the HFG2.0. Default values for these variables are loaded into the EEPROM at the PECC factory. The Set-Up parameters are reloaded into the system registers each time the HFG2.0 is powered up or reset. See Table 3-5 for typical Set-Up parameters.

Users can change the Set-Up parameters to better suit their specific applications. These parameters are uploaded to the HFG2.0 via the RS232 interface using PECC's ActWiz software. The Set-Up parameters can only be accessed when the HFG2.0 is in the Power Up / Set Up state. See the Basic Operation Flow Chart in Figure 3-1 and the Power Up / Set Up State section below for details.

Contact PECC for a copy of ActWiz software. See the ActWiz Software Manual for further details.

Power Up / Set-Up State

The HFG2.0 is in Power Up / Set Up state immediately after the HFG2.0 has been powered up or reset. This is after the system registers have been cleared and the Set Up parameters have been reloaded, but before the Homing process has begun (RUN command = OFF). This is the only state in which the user can communicate with HFG2.0 via the RS232 interface. In this state, a set-up file can be downloaded to view the current Set-Up parameters or uploaded to establish new Set-Up parameters. A Fault file can also be downloaded, also using the ActWiz software. Please see the ActWiz software manual for more information.



CAUTION

The HFG2.0 will not hold position when communicating with ActWiz software. The return spring causes the poppets to return to the soft seats, thereby closing the valve.

A fault file also can be downloaded when the HFG2.0 is in the Power Up / Set Up state by using ActWiz software via the RS232 interface. The fault file will provide fault information and possible causes

PARAMETER	DESCRIPTION	FACTORY SETTING
Part Number	Describes part number of actuator model	Per Drawing
Actuator Type	Describes type of actuator	Stand Alone
Command Source	Sets type of command signal	Analog
Home	Controls the direction the actuator will move, extending or retracting, to find the mechanical stop (HOME)	Extend
Span	Sets the maximum stroke length, measured from the HOME position	1.0 inches
Stop Position	Sets the signal loss position, measured from the HOME position	0.0 inches
Interpolation Table	Sets how Demand signal is interpolated between defined points	Linear
Position Loop Constant		63
Current Loop PID Constants		
Proportional		2.0
Integral		200
Derivative		0
Velocity Loop PID Constants		
Proportional		30
Integral		3,000
Derivative		0
Maximum Velocity	Sets the maximum velocity	10 in/s
Maximum Force	Sets the maximum force output	1267 lbf
Maximum Homing Velocity	Sets the maximum velocity used to find the HOME position	0.5 in/s
Maximum Homing Force	Sets the maximum force the HFG2.0 will use to find the HOME position	500 lbf
Maximum Holding Force	Sets the maximum force to be used to hold at the HOME position while the position demand is < 4.1mA and > 2mA	500 lbf

Table 3-5. Typical HFG2.0 Setup Parameters With Default Values



INTENTIONALLY BLANK

4 MAINTAINING THE HFG2.0

Under normal operation, the HFG2.0 requires no formal maintenance program.

Regularly scheduled inspections should be performed to check for:

- any damage to wire insulation on integral 17-wire signal harness
- any damage to wire insulation on integral 4-wire power harness
- actuator-to-valve alignment (or actuator-to-load alignment)
- any damage to housing or mounting hardware
- any damage to power and signal harnesses
- parts that are worn, loose, or shifted due to shock, vibration, etc.

4.1 Refurbishment

PECC recommends that the HFG2.0 be shipped back to the factory for refurbishment when the user's system is shut down for overhaul (typically after approximately 30,000 hours of operation.) Contact PECC for details about refurbishment.



INTENTIONALLY BLANK

5 TROUBLESHOOTING

This section provides troubleshooting information for the HFG2.0. You can isolate most electrical faults by using an external oscilloscope and digital voltmeter (DVM) and computer with diagnostic software.

The HFG2.0 is comprised of highly reliable components and should not develop service problems under normal operating conditions. However, over a period of time and service, failures may develop. Whoever is responsible for fault analysis should be thoroughly acquainted with physical and electrical configurations, Theory of Operation (Section 2), and Installation (Section 1).

Resolve problems noted during operation or maintenance as soon as possible. The causes of many problems can be traced through the information contained in the block diagram shown in Section 2.



CAUTION

Continuing to operate the valve in a malfunctioning condition is hazardous to personnel and can cause property damage.

Tables 5-1 and 5-2 list common failures that can occur before or after valve installation, respectively.

In addition, the HFG2.0 has on-board troubleshooting capability. The ActWiz software has a fault file that you can upload to pinpoint a failure cause. See the ActWiz Software Manual for more details.

If, after following the troubleshooting procedures, you still can't find the cause of the problem and repair it, contact the factory for assistance.

Symptom	Probable Causes	Corrective Action
Valve Inoperative - FAULT alarm	Power Wires not connected No or low 120 VDC power	Ensure RED and GREEN wires correctly connected to valve Ensure 120 VDC Primary System Power at valve
Valve Inoperative - NO FAULT alarm	No RUN or position command	Ensure VIOLET and WHITE/VIOLET wires correctly connected to valve Ensure 24 VDC RUN and position command at valve
Actuator moves toward HOME then stops	Intermittent RUN command Homing Force Too Low No position demand	Ensure consistent 24 VDC RUN command and fuel demand signal Ensure position command at valve
Actuator moves toward HOME intermittently	Intermittent RESET command	Ensure GRAY and WHITE/GRAY wires correctly connected to Actuator Ensure consistent 24 VDC RESET command
Actuator finds HOME then moves to STOP position	No fuel demand signal	Ensure BROWN and WHITE/BROWN wires correctly connected to Actuator Ensure fuel demand > 2.0 mA at Actuator
Valve does not track fuel demand	No fuel demand signal or RUN command	Ensure BROWN and WHITE/BROWN wires correctly connected to valve Ensure valve demand > 4.1 mA at valve Ensure RUN command present at valve
Valve does not hold consistent position-oscillates or dithers	Varying fuel demand signal No or low 120 VDC power	Ensure stable fuel demand at the actuator Ensure 120 VDC at valve
No valve feedback	Valve feedback wires not connected No or low 120 VDC power Self-protective valve auto shut down No RUN command	Ensure YELLOW and WHITE/YELLOW wires correctly connected Ensure 120 VDC at valve Upload Fault File- check for motor windings over - temperature faults. Check for valve contamination Ensure RUN command present at valve
No motor current feedback	Motor current wires not connected No or low 120 VDC power No RUN command	Ensure BLUE and WHITE/BLUE wires correctly connected Ensure 120 VDC at valve Ensure RUN command present at valve
Valve Operative- FAULT alarm active	FAULT wiring incorrect Internal FAULT	Ensure ORANGE and WHITE/ORANGE wires correctly connected to Actuator Upload Fault File to identify source of fault
Valve Operative- OVER TEMP alarm active	OVERTEMP wiring incorrect Electronics or motor winding temperature out of range Valve jammed	Ensure BLACK and WHITE/BLACK wires correctly connected to valve Reduce External ambient temperature Check for valve contamination
Valve leaks when closed	Poppet assembly fouled Valve installed backwards	Stroke valve OPEN and clear foul at orifice Ensure supply is connected to valve IN port

Symptom	Probable Causes	Corrective Action
RS232 Interface Inoperative	<p>Incorrect wiring</p> <p>No or low 120 VDC power COM1 not connected RESET or RUN command is ON</p>	<p>Ensure WHITE/ORANGE/YELLOW, WHITE/ORANGE/BLUE, WHITE/ORANGE/GREEN wires correctly connected to valve and laptop PC.</p> <p>Ensure 120 VDC Primary System Power at Valve Check laptop/PC com port Remove RESET or RUN command</p>

Table 5-1. Initial Installation Troubleshooting Chart

Symptom	Probable Causes	Corrective Action
No valve feedback	<p>No or low 120 VDC power Self-protective valve auto shut down</p>	<p>Ensure 120 VDC at valve Upload Fault File- check for motor windings over - temperature faults. Check for valve contamination</p>
FAULT alarm	Various	<p>Upload Fault File to identify source of fault Clear indicated fault</p>
OVER TEMP alarm	<p>Ambient temperature limit exceeded</p> <p>Electronics or motor winding temperature out of range</p>	<p>Allow actuator to cool and re-start Reduce ambient temperature</p> <p>Check for valve contamination</p>
FAULT and OVERTEMP alarm	<p>No 120 VDC Power DSP Failure</p>	<p>Ensure 120 VDC at actuator Contact factory</p>

Table 5-2. HFG2.0 In-Service Troubleshooting Chart

For troubleshooting purposes, use Table 5-3 to verify the valve electrical continuity integrity.

Disconnect the HFG2.0 power and digital harness connectors and use a digital multi-meter (DMM) to check the resistance values between the wires indicated on the table. If an open circuit is detected, send the HFG2.0 to Precision Engine Controls Corporation for test and repair.



WARNING – Shock Hazard

Remove all power to the HFG2.0 prior to continuity check.

Function	Actuator Wire Colors	Resistance Value
DEMAND	BRN and WHT/BRN	225 Ω
RUN	VIO and WHT/VIO	4.7 K Ω
RESET	GRY and WHT/GRY	4.7 K Ω
POWER	RED and GREEN	High Impedance, but not open circuit.
MOTOR CURRENT	BLU and WHT/BLU	High Impedance
POSITION	YEL and WHT/YEL	High Impedance
FAULT Alarm	ORN and WHT/ORN	High Impedance
OVERTEMP Alarm	BLK and WHT/BLK	High Impedance



Table 5-3. HFG2.0 Electrical Continuity Troubleshooting Chart

5.1 FAULT File









The FAULT and OVERTEMP alarms are discrete outputs from the HFG2.0. The FAULT and OVERTEMP alarm circuits are closed in the normal operating condition. If the HFG2.0 detects a fault, the alarm circuit for that fault opens, and the user-provided controller should detect the open circuit. The fault is recorded in the fault file.

The HFG2.0 firmware captures the fault data in the EEPROM. If the HFG2.0 is operational, a fault file can be downloaded using ActWiz software via the RS232 interface. The fault file will provide fault information and possible causes. The HFG2.0 must be in the Power Up / Set Up state to download the fault file. See Section 3.8 for details about the Power Up / Set Up state. Contact Precision Engine Controls Corporation to request ActWiz software.

Should a fault occur, the user should shut down to troubleshoot the failure. Removing 120 VDC power shuts down the HFG2.0. Toggling the RESET command will clear the fault, but it does NOT clear the fault file.

 **Note:** The fault file only records the programmable faults that have been enabled .

Fault Descriptions

The following are brief description of some of the faults that can be detected by the HFG2.0. See Section 3.7 and Table 3-1 , Table 3-2 , Table 3-3   , and Table 3-4    for additional details about system faults.

Driver over-current

The maximum MCE current output limit is 25 amps. If the MCE is outputting its maximum current for ten (10) seconds, the MCE signals a fault.

If MCE maximum current drop below the maximum current, the fault signal is cleared.

Tracking error

The HFG2.0 position should continuously track demand. Should the position versus demand vary more than one motor revolution (0.20 inches) for more than ten (10) seconds, the MCE signals a fault.

If the position returns to within one motor revolution, the fault signal is cleared.

Watchdog expired

The MCE watchdog timer continuously monitors the firmware program. Should the MCE firmware program stop functioning, or attempt to access an illegal address, the MCE signals a fault.

This fault does not clear without RESET command.



Resolver to Digital Converter (RDC) failure

The MCE contains a resolver to digital converter chip (RDC) that provides position feedback information to the DSP. The RDC chip has on-board health monitoring.

If the RDC detect an internal tracking error, a signal is sent to the MCE. Upon receipt, the MCE signals a fault.

This fault does not clear without RESET command.

Unregulated Voltage Low





The MCE signals a fault if the reference voltage drops below minimum for ten (10) seconds   .

If the voltage returns to acceptable level, the fault signal is cleared.

+/- 14V High/Low

The MCE signals a FAULT if the internal ± 14 VDC power supplies exceed operating limits. This fault does not clear without RESET command.

Input voltage High/Low

The MCE signals a fault if the 120 VDC supply exceeds 180 VDC or drops below 75 VDC for more than 7.5 seconds    (1 second for ). This fault clears when the 120 VDC supply voltage returns.

APPENDIX A: DECOMMISSIONING & DISPOSAL

This section contains recommended HFG2.0 decommissioning and disposal practices. It is for permanent removal or replacement of the installed product, with no intentions of rework, overhaul, or to be used as spares.

For removal follow proper lockout /tagout procedures and verify no live electrical circuits:

- Disconnect the 4 wires of the integral power harness to the HFG2.0.
- Disconnect the 17 wires of the integral signal harness to the HFG2.0
- Disconnect the ground wire from the HFG2.0 chassis
- Disconnect the fuel inlet pipe
- Disconnect the fuel outlet pipe



Note: Follow local environmental codes in regards to disposal of electronic components, specifically all electrolytic capacitors.



INTENTIONALLY BLANK

APPENDIX B: GLOSSARY

Term	Definition
RUN Command	A discrete 24 VDC signal that enables the HFG2.0 actuator and valve to move.
RESET Command	A discrete 24 VDC signal that causes the HFG2.0 internal program (firmware) to jump to the beginning.
Controller	A user-provided computer that executes commands to the HFG2.0 and accepts analog and discrete feedback.
Fuel Demand	A 4 mA to 20 mA signal that commands the HFG2.0 to move to a certain actuator/valve position. The signal is scaled with SPAN.
Position Demand Feedback	A 4 mA to 20 mA signal that communicates the actual HFG2.0 actuator/valve position to the controller.
Motor Current Feedback	A 4 mA to 20 mA signal that is proportional to the HFG2.0 motor current. The signal is scaled with Max. Force.
FAULT alarm	A discrete signal from the HFG2.0 that communicates an internal failure. The user's controller will see an open circuit when a FAULT alarm is active.
OVERTEMP alarm	A discrete signal from the HFG2.0 that communicates an internal over temperature; electronics or motor. The user's controller will see an open circuit when the OVERTEMP alarm is active.
HOME	A mechanical rigid stop from which the HFG2.0 calculates position. HOME is found at start-up during the Homing sequence. The HFG2.0 defines HOME when the motor current exceeds the HOMING FORCE and velocity is zero. HOME is defined as the actuator/valve position when the Demand signal is 4 mA. HOME is the Valve Closed condition for the HFG2.0
Homing sequence	When the HFG2.0 extends or retracts to find a rigid mechanical stop.
SPAN	Maximum distance from HOME. SPAN is defined as the position when the Demand signal is 20 mA.
STOP position	A user-defined position between HOME and SPAN that the HFG2.0 travels to upon loss of RUN or position Demand signal.
Maximum Velocity	A user defined maximum velocity in inches per second.
Maximum Homing Force	A user defined maximum homing force output setting. The motor control electronics uses this setting to determine the maximum motor current in the Homing sequence.
Maximum Holding Force	A user-defined maximum force while in the Holding Motor Current state.



INTENTIONALLY BLANK

Free Manuals Download Website

<http://myh66.com>

<http://usermanuals.us>

<http://www.somanuals.com>

<http://www.4manuals.cc>

<http://www.manual-lib.com>

<http://www.404manual.com>

<http://www.luxmanual.com>

<http://aubethermostatmanual.com>

Golf course search by state

<http://golfingnear.com>

Email search by domain

<http://emailbydomain.com>

Auto manuals search

<http://auto.somanuals.com>

TV manuals search

<http://tv.somanuals.com>