

CENTRALPNEUMATIC®

30 Gallon, 180 PSI Gas Powered Two-Stage Air Compressor

67853 Air Compressor

⚠ DANGER

Using an engine indoors CAN KILL YOU IN MINUTES.

Engine exhaust contains carbon monoxide. This is a poison you cannot see or smell.



NEVER use inside a home or garage, EVEN IF doors and windows are open.

Only use OUTSIDE and far away from windows, doors, and vents.

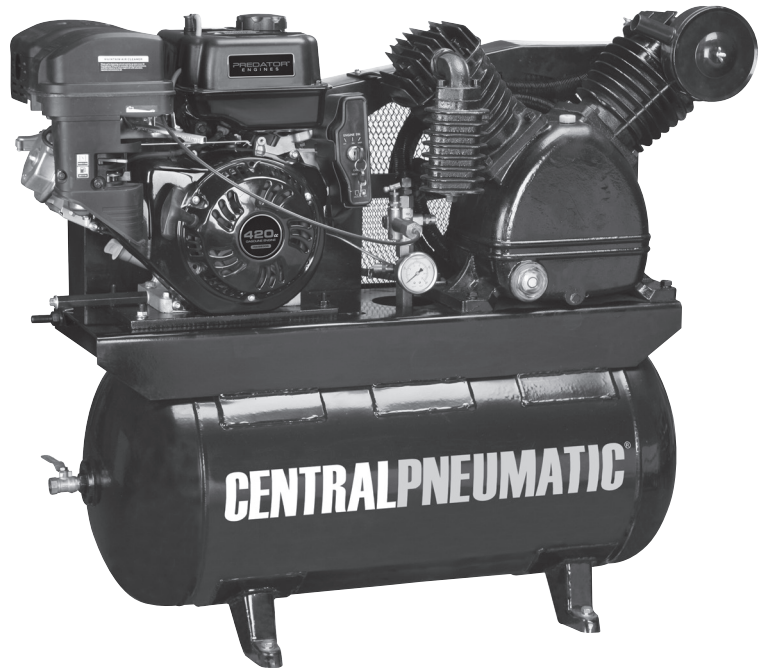

When unpacking, make sure that the product is intact and undamaged. If any parts are missing or broken, please call 1-800-444-3353 as soon as possible.

Record Product's Serial Number Here: _____

Note: If product has no serial number, record month and year of purchase instead.

Note: Some parts are listed and shown for illustration purposes only, and are not available individually as replacement parts.

Visit our website at: <http://www.harborfreight.com>
Email our tech support at: tech@harborfreight.com

Copyright© 2010 by Harbor Freight Tools®. All rights reserved. No portion of this manual or any artwork contained herein may be reproduced in any shape or form without the express written consent of Harbor Freight Tools. Diagrams within this manual may not be drawn proportionally. Due to continuing improvements, actual product may differ slightly from the product described herein. Tools required for assembly and service may not be included.

Manual Revised 11e

Download from [Www.Somanuals.com](http://www.Somanuals.com). All Manuals Search And Download.

Save This Manual

Keep this manual for the safety warnings and precautions, assembly, operating, inspection, maintenance and cleaning procedures. Write the product's serial number in the back of the manual near the assembly diagram (or month and year of purchase if product has no number). Keep this manual and the receipt in a safe and dry place for future reference.

Safety Warnings

In this manual, on the labeling, and all other information provided with this product:



This is the safety alert symbol. It is used to alert you to potential personal injury hazards. Obey all safety messages that follow this symbol to avoid possible injury or death.

! DANGER

DANGER indicates a hazardous situation which, if not avoided, will result in death or serious injury.

! WARNING

WARNING indicates a hazardous situation which, if not avoided, could result in death or serious injury.

! CAUTION

CAUTION, used with the safety alert symbol, indicates a hazardous situation which, if not avoided, could result in minor or moderate injury.







NOTICE

NOTICE is used to address practices not related to personal injury.

CAUTION

CAUTION, without the safety alert symbol, is used to address practices not related to personal injury.

Symbol Definitions

Symbol	Property or Statement
RPM	Revolutions Per Minute
HP	Horsepower
	WARNING marking concerning Risk of Eye Injury. Wear ANSI-approved safety goggles with side shields.
	Read the manual before set-up and/or use.
	WARNING marking concerning Risk of Hearing Loss. Wear hearing protection.
	WARNING marking concerning Risk of Respiratory Injury. Operate engine OUTSIDE and far away from windows, doors, and vents.
	WARNING marking concerning Risk of Fire while handling fuel. Do not smoke while handling fuel.
	WARNING marking concerning Risk of Fire. Do not refuel while operating. Keep flammable objects away from engine.
	WARNING marking concerning Risk of Explosion.



WARNING! Read all instructions.

Failure to follow all instructions listed below may result in fire, serious injury and/or DEATH.

The warnings and precautions discussed in this manual cannot cover all possible conditions and situations that may occur. It must be understood by the operator that common sense and caution are factors which cannot be built into this product, but must be supplied by the operator.

SAVE THESE INSTRUCTIONS

Set up Precautions

1. Gasoline fuel and fumes are flammable, and potentially explosive. Use proper fuel storage and handling procedures. Do not store fuel or other flammable materials nearby.
2. Have multiple ABC class fire extinguishers nearby.
3. Operation of this equipment may create sparks that can start fires around dry vegetation. A spark arrestor may be required. The operator should contact local fire agencies for laws or regulations relating to fire prevention requirements.

4. Set up and use only on a flat, level, well-ventilated surface.
5. Use only lubricants and fuel recommended in the engine manual or in the Specifications chart of this manual.
6. Wear ANSI-approved safety goggles, heavy-duty work gloves, and dust mask/respirator during set up.

Engine Precautions

Follow engine precautions and instructions in the included engine instruction manual.

Operating Precautions

1.  **CARBON MONOXIDE HAZARD**
Using an engine indoors **CAN KILL YOU IN MINUTES.**
Engine exhaust contains carbon monoxide. This is a poison you cannot see or smell.

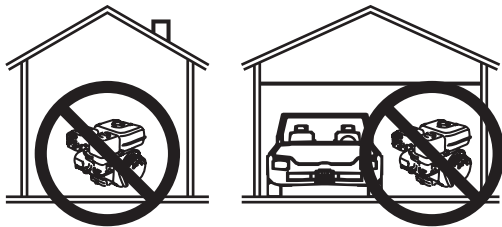

NEVER use inside a home or garage, EVEN IF doors and windows are open.

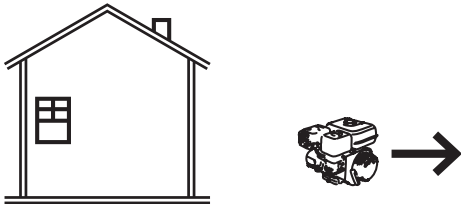

Only use OUTSIDE and far away from windows, doors, and vents.

2. Keep children away from the equipment, especially while it is operating.
3. Fire Hazard! Do not fill gas tank while Compressor engine is running. Do not operate if gasoline has been spilled. Clean spilled gasoline before starting engine. Do not operate near pilot light or open flame.
4. Do not touch Compressor engine during use. Let engine cool down after use.
5. Never store fuel or other flammable materials near the Compressor engine.
6. Only use a suitable means of transport and lifting devices with sufficient weight bearing capacity when transporting the Compressor.
7. Secure the Compressor on transport vehicles to prevent the tool from rolling, slipping, and tilting.
8. Industrial applications must follow OSHA requirements.
9. Do not leave the equipment unattended when it is running. Turn off the equipment (and remove safety keys, if available) before leaving the work area.
10. Wear ANSI-approved safety glasses, hearing protection, and NIOSH-approved dust mask/respirator under a full face shield along with steel-toed work boots during use.
11. People with pacemakers should consult their physician(s) before use. Electromagnetic fields in close proximity to a heart pacemaker could cause pacemaker interference or pacemaker failure. Caution is necessary when near the engine's magneto or recoil starter.
12. Use only accessories that are recommended by Harbor Freight Tools for your model. Accessories that may be suitable for one piece of equipment may become hazardous when used on another piece of equipment.
13. Do not operate in explosive atmospheres, such as in the presence of flammable liquids, gases, or dust. Gasoline-powered engines may ignite the dust or fumes.
14. Stay alert, watch what you are doing and use common sense when operating this piece of equipment. Do not use this piece of equipment while tired or under the influence of drugs, alcohol or medication.
15. Do not overreach. Keep proper footing and balance at all times. This enables better control of the equipment in unexpected situations.
16. Dress properly. Do not wear loose clothing or jewelry. Keep hair, clothing and gloves away from moving parts. Loose clothes, jewelry or long hair can be caught in moving parts.
17. Parts, especially exhaust system components, get very hot during use. Stay clear of hot parts.
18. Do not cover the engine or equipment during operation.
19. Keep the equipment, engine, and surrounding area clean at all times.
20. Use the equipment, accessories, etc., in accordance with these instructions and in the manner intended for the particular type of equipment, taking into account the working conditions and the work to be performed. Use of the equipment for operations different from those intended could result in a hazardous situation.
21. Do not operate the equipment with known leaks in the engine's fuel system.
22. This product contains or, when used, produces a chemical known to the State of California to cause cancer and birth defects or other reproductive harm. (California Health & Safety Code § 25249.5, *et seq.*)
23. When spills of fuel or oil occur, they must be cleaned up immediately. Dispose of fluids and cleaning materials as per any local, state, or federal codes and regulations. Store oil rags in a bottom-ventilated, covered, metal container.

24. Keep hands and feet away from moving parts. Do not reach over or across equipment while operating.
25. Before use, check for misalignment or binding of moving parts, breakage of parts, and any other condition that may affect the equipment's operation. **If damaged, have the equipment serviced before using.** Many accidents are caused by poorly maintained equipment.
26. Use the correct equipment for the application. Do not modify the equipment and do not use the equipment for a purpose for which it is not intended.

Service Precautions

1. **Before service, maintenance, or cleaning:**
 - a. **Turn the engine switch to its "OFF" position.**
 - b. **Allow the engine to completely cool.**
 - c. **Then, remove the spark plug cap from the spark plug.**
2. Keep all safety guards in place and in proper working order. Safety guards include muffler, air cleaner, mechanical guards, and heat shields, among other guards.
3. **Do not alter or adjust any part of the equipment or its engine that is sealed by the manufacturer or distributor. Only a qualified service technician may adjust parts that may increase or decrease governed engine speed.**
4. Wear ANSI-approved safety goggles, heavy-duty work gloves, and dust mask/respirator during service.
5. Maintain labels and nameplates on the equipment. These carry important information. If unreadable or missing, contact Harbor Freight Tools for a replacement.
6. Have the equipment serviced by a qualified repair person using only identical replacement parts. This will ensure that the safety of the equipment is maintained. Do not attempt any service or maintenance procedures not explained in this manual or any procedures that you are uncertain about your ability to perform safely or correctly.

7. Store equipment out of the reach of children.
8. Follow scheduled engine and equipment maintenance.

Air Compressor Safety Warnings

1. Risk of fire or explosion - Do not spray flammable liquid in a confined area or towards a hot surface. Spray area must be well-ventilated. Do not smoke while spraying or spray where spark or flame is present. Arcing parts - Keep compressor at least 20 feet away from explosive vapors, such as when spraying with a spray gun.
2. Risk of bursting - Do not adjust regulator higher than maximum stated pressure of attachment.
3. Risk of injury - Do not direct air stream at people or animals.
4. Do not use to supply breathing air.
5. Do not use the air hose to move the compressor.
6. Drain Tank daily and after use. Internal rust causes tank failure and explosion.
7. **Add correct amount of compressor oil before first use and every use. Operating with the incorrect amount of oil causes permanent damage and voids warranty. To prevent damage, do not use with overfilled or low oil.**
8. Compressor head gets hot during operation. Do not touch it or allow children nearby during or immediately following operation.
9. Release the pressure in the storage tank before moving.
10. The use of accessories or attachments not recommended by the manufacturer may result in a risk of injury to persons.
11. All air line components, including hoses, pipe, connectors, filters, etc., must be rated for a minimum working pressure of 125 PSI, or 150% of the maximum system pressure, whichever is greater.



SAVE THESE INSTRUCTIONS.

Engine Controls

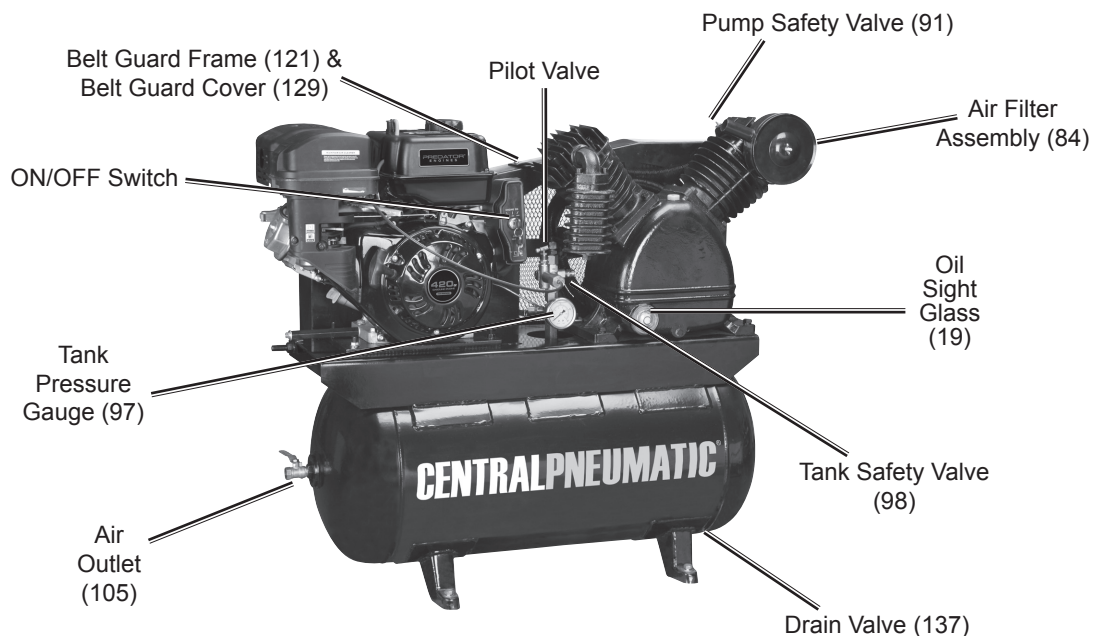

1. **Belt Guard** - The Belt Guard encloses the pulleys and drive belts. It protects the user from the moving parts and allows the large pulley to direct cooling air to the Air Pump.
2. **Oil Sight Glass** - The oil sight glass shows proper level of the oil. Oil level should be at center of Sight Glass.
3. **Tank Drain Valve** - The Air Tank Drain Valve allows moisture to be removed from the tank to prevent corrosion.
4. **Safety Valve** - The Safety Valve automatically releases air if the Air Tank pressure exceeds the preset maximum. In an emergency, the ring can be pulled to relieve tank air pressure. There is one safety valve on the pump and one on the tank.
5. **Air Outlet** - An air hose attaches to this valve. Air pressure required by tools is set by an air pressure regulator.
6. **Air Storage Tank** - The Air Tank is where air pressurized by the Air Pump is stored for use.
7. **Tank Pressure Gauge** - The Air Tank Pressure Gauge displays the air pressure in the tank.
8. **Pilot Valve** - Open the Pilot Valve before starting the engine. It relieves resistance on the engine to make starting possible. Rotate the pin so it is vertical to open it. Once the engine is running, close the Pilot Valve so the Compressor can build up pressure.

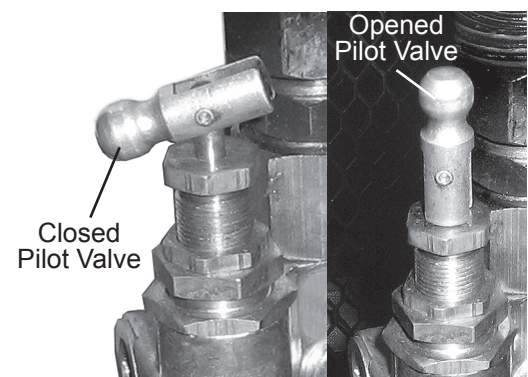
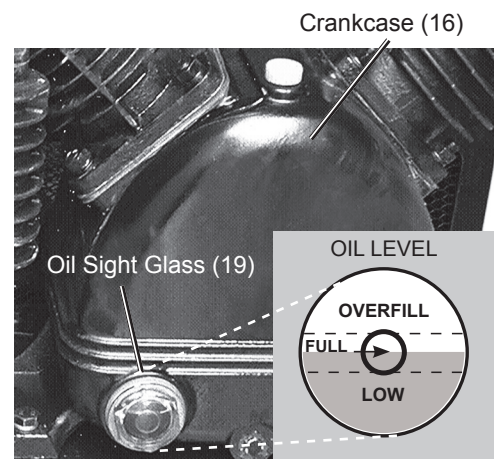

Set up

The emission control system for this Compressor's Engine is warranted for standards set by the U.S. Environmental Protection Agency and by the California Air Resources Board (also known as CARB). For warranty information, refer to the engine manual.

Mounting to a Truck bed

1. Before mounting, if needed, reinforce the area with plywood or steel plating.
2. With assistance, move the compressor to the truck bed location and mark the floor of the truck bed through the holes in the compressor's feet. Check for any hidden wiring or cables and adjust the location for the holes as needed. Then, temporarily set the compressor aside.
3. Drill the four 1/2" diameter holes through the truck bed and any reinforcing materials.
4. Set the compressor back in place, and align the foot holes with the pre-drilled holes. Use four 1/2" diameter, bolts, washers and lock washers (all not included) to secure the compressor in place.

Assembly

To install the Air Filter Assembly (84), fit the Connector into the Air Filter Assembly and slide the assembly into the hole on the side of the First Stage Cylinder Head (61). Secure in place with the Wing Nut.

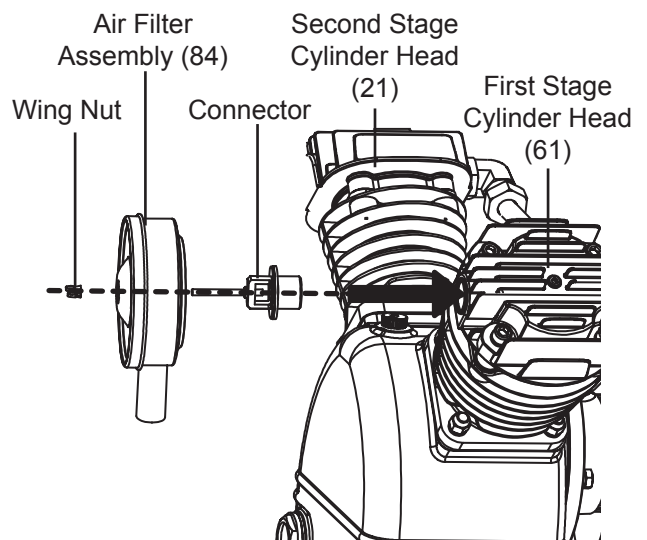

Break-In Compressor

Break in the new Air Compressor as follows:

- a. Make sure the engine is off. Open the air outlet valve on the left side of the tank.
- b. Check all fluid levels in the engine and pump.
- c. Start the engine following the General Operating Instructions.
- d. Let the unit run for 30 minutes. Air will expel freely through the Coupler.
- e. Turn OFF the engine.
- f. Remove the male coupler.

Connection

Connect a regulator valve, an in-line shut off valve and a 1/2" NPT air hose (all sold separately) to the Quick Coupler. The air hose must be long enough to reach the work area with enough extra length to allow free movement while working.

Note: An in-line shutoff ball valve is an important safety device because it controls the air supply even if the air hose is ruptured. The shutoff valve should be a ball valve because it can be closed quickly.

1. Depending on the tool which you will be using with this compressor, you may need to incorporate additional components, such as an in-line oiler, a filter, or a dryer (all sold separately). Consult your air tool's manual for needed accessories. See Typical Air Line Setup charts on the following pages. This is a truckbed compressor, so use the portable setup as a model.

Air Tool & Spray Gun Portable Setup

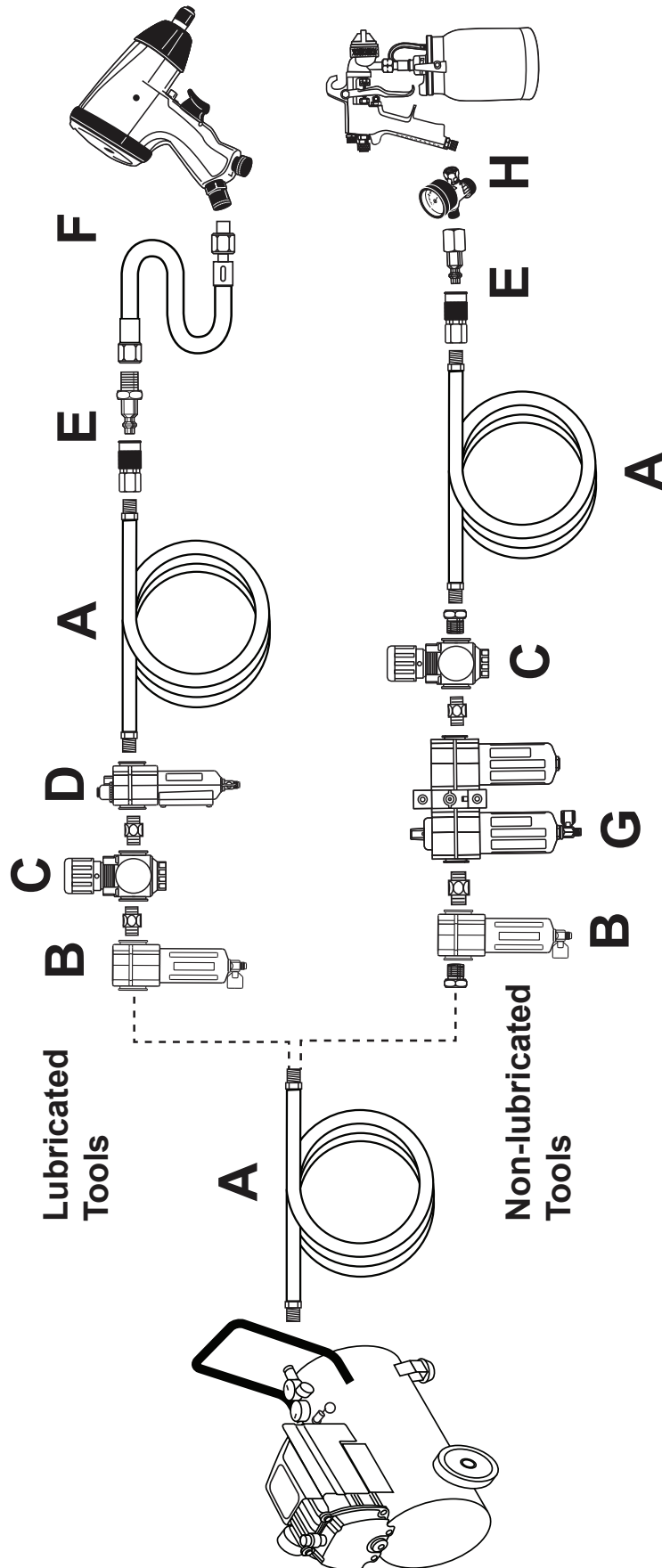

Description	Function
A Air Hose	Connects air to tool
B Filter	Prevents dirt and condensation from damaging tool or work piece
C Regulator	Adjusts air pressure to tool
D Lubricator (optional)	For air tool lubrication
E Coupler and Plug	Provides quick connection and release
F Leader Hose (optional)	Increases coupler life
G Air Cleaner / Dryer (optional)	Prevents water vapor from damaging work piece
H Air Adjusting Valve (optional)	For fine tuning airflow at tool

Air Tool & Spray Gun Stationary Setup

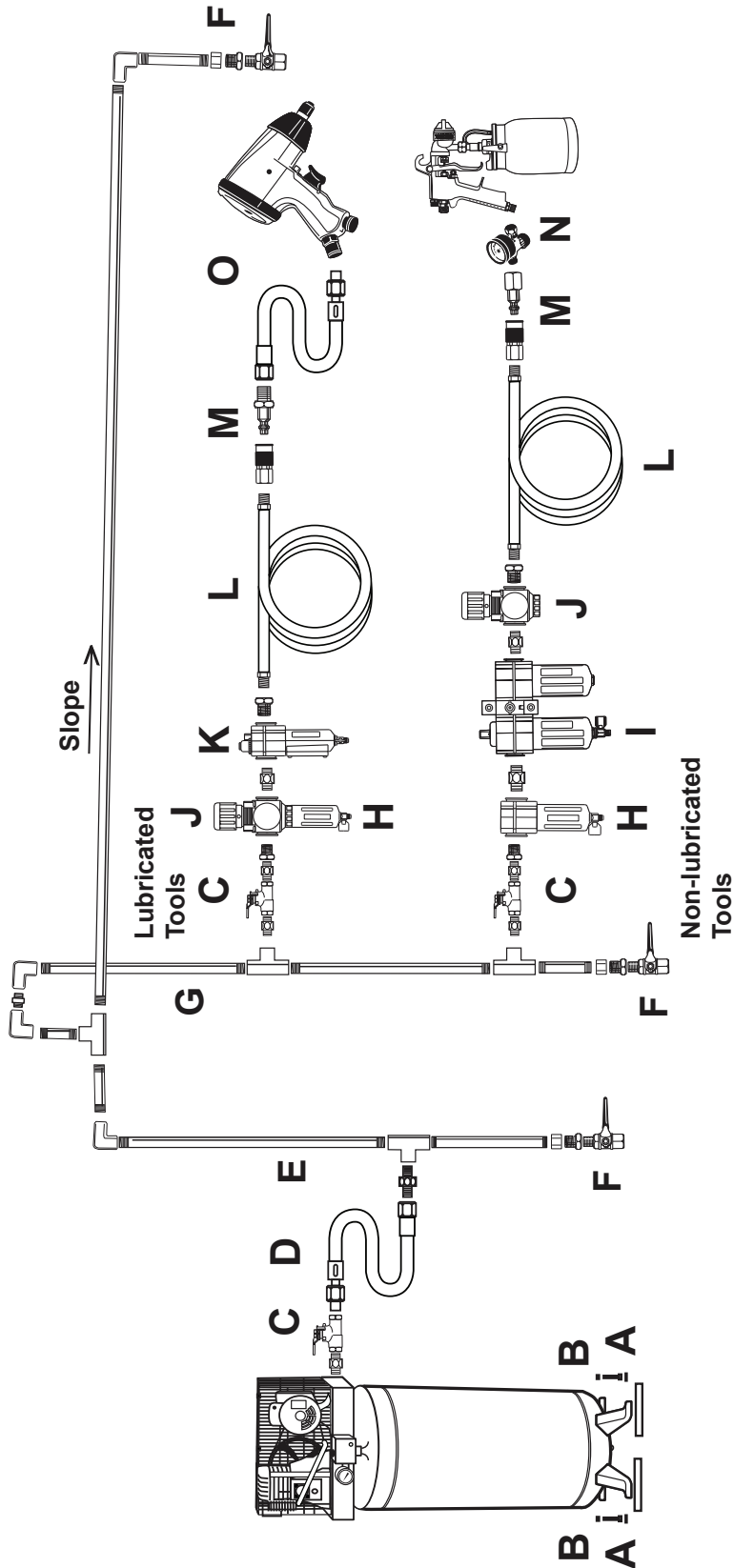

Description	Function
A Vibration Pads	For noise and vibration reduction
B Anchor Bolts	Secures air compressor in place
C Ball Valve	Isolates sections of system for maintenance
D Isolation Hose	For vibration reduction
E Main Air Line - 3/4" minimum recommended	Distributes air to branch lines
F Ball Valve	To drain moisture from system
G Branch Air Line - 1/2" minimum recommended	Brings air to point of use
H Filter	Prevents dirt and condensation from damaging tool or work piece
I Air Cleaner / Dryer (optional)	Prevents water vapor from damaging work piece
J Regulator	Adjusts air pressure to tool
K Lubricator	For air tool lubrication
L Air Hose	Connects air to tool
M Coupler and Plug	Provides quick connection and release
N Air Adjusting Valve	For fine tuning airflow at tool
O Leader Hose	Increases coupler life

Operation



Read the **ENTIRE IMPORTANT SAFETY INFORMATION** section at the beginning of this manual including all text under subheadings therein before set up or use of this product.

Using the Compressor

Inspect Compressor, engine, pump and equipment looking for damaged, loose, and missing parts before set up and starting. If any problems are found, do not use equipment until fixed properly.

Note: At the beginning of the day's first use of the Air Compressor, check for air leaks by applying soapy water to connections while the Air Compressor is pumping and after pressure cut-out. Look for air bubbles. If air bubbles are present at connections, tighten connections. Do not use the air compressor unless all connections are air tight. The extra air leaking out will cause the compressor to operate too often, increasing wear on the compressor.

Before starting the Compressor:



- Follow the Set Up Instructions in the equipment manual to prepare the equipment.
- Follow the Set Up Instructions in the Engine manual to prepare the engine.
- Inspect all components of the setup. Make sure all nuts and bolts are tight.
- Fill the Engine with the proper amount and type of both fuel and oil.
- Fill the Compressor Pump with compressor oil following the Maintenance Instructions in this manual.

To Start and Use the Compressor

1. Close the Drain Valve (137) by turning the lever up so that it is perpendicular to the valve.

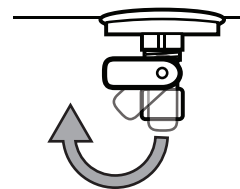

2. Close the in-line Shutoff Valve between the compressor and the air hose.

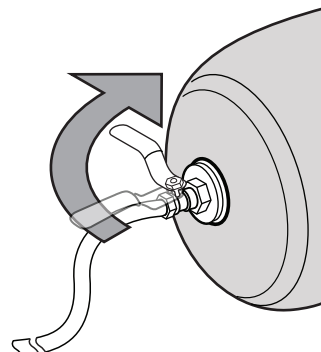

3. Open the Pilot Valve by rotating it to a vertical position.

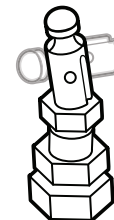

4. Open the Fuel Valve.

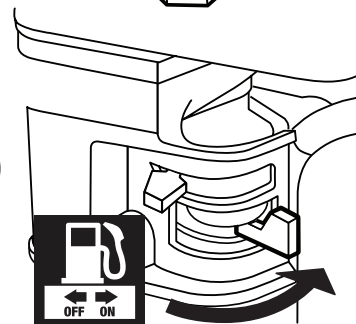

5. To start a cold engine, move the Choke to the CHOKE (start/closed) position.
To restart a warm engine, leave the Choke in the RUN position.

5

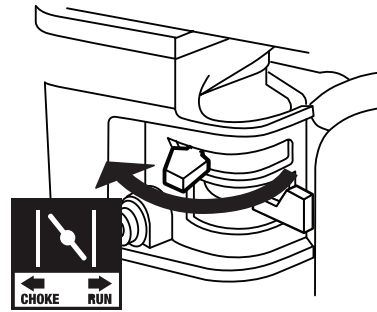

6. For MANUAL START

- A. Turn the Engine Switch to ON.

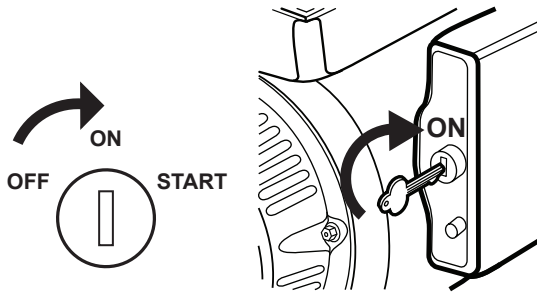

- B. Grip the Starter Handle of the Engine loosely and pull it slowly several times to allow the gasoline to flow into the Engine's carburetor. Then pull the Starter Handle gently until resistance is felt. Allow Cable to retract fully and then pull it quickly. Repeat until the engine starts. **Note:** Do not let the Starter Handle snap back against the engine. Hold it as it recoils so it doesn't hit the engine.

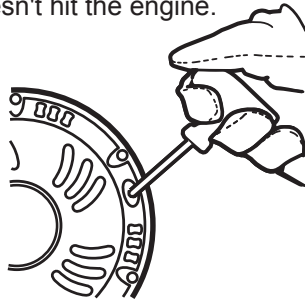

For ELECTRIC START

- Turn the Engine Switch to START.

Note: To prolong starter life, use short starting cycles (5 seconds maximum). Then wait one minute before attempting to start again.

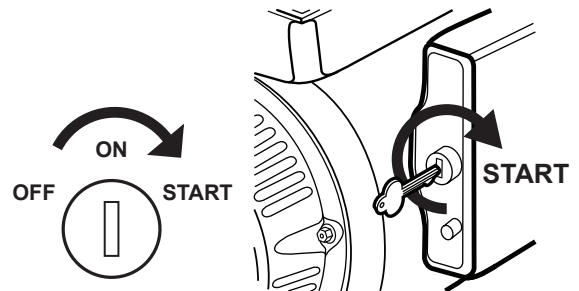

7. Allow the Engine to run for several seconds. Then, if the Choke lever is in the CHOKE position, move the Choke Lever very slowly to its RUN position.

Note: Moving the Choke Lever too fast could kill the engine.

7

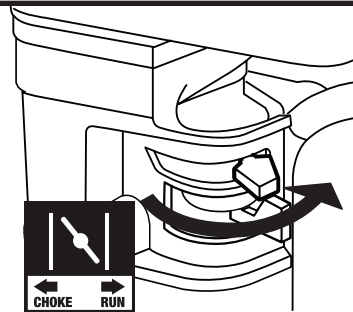

8. Close the Pilot Valve by rotating it to a horizontal position.

8

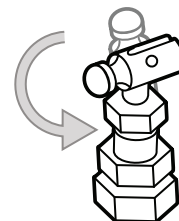

9. When the Gas Engine is started and running, the compressor Pump starts compressing air into the Air Tank. Open the in-line Shutoff Valve and adjust the Pressure Regulator (sold separately) so that the air output is enough to properly power the tool, but the output will not exceed the tool's maximum air pressure at any time. Turn the knob clockwise to increase the pressure and counterclockwise to decrease pressure. Adjust the pressure gradually, while checking the air output gauge to set the pressure.

9

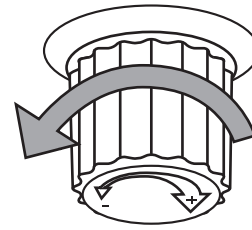

IMPORTANT: Allow the engine to run for five minutes with no load after each start-up so that the engine can stabilize.

Maintenance Break-in Period:

Breaking-in the engine will help to ensure proper equipment and engine operation. The **maintenance** break-in period will last about 20 hours of use. After this period, change the engine oil.

Under normal operating conditions, subsequent maintenance follows the schedule explained in the MAINTENANCE AND SERVICING section.

Note: When maximum tank pressure is reached, the compressor automatically disengages, and the engine RPM drops down to idle speed. The engine remains at idle until Air Tank pressure falls to a preset level. The Gas Engine will then accelerate and air pressure once again begins to build up in the Air Tank.

Note: As long as the engine is running, the operation of the Air Compressor is automatic, controlled by an internal pressure switch.

IMPORTANT: The internal pressure switch is not user adjustable; **do not make changes to the air pressure settings of the internal pressure switch.** Any change to the automatic pressure levels may cause excess pressure to accumulate, causing a hazardous situation.

Note: Depressurization - If it is necessary to quickly *depressurize* the Compressor, turn OFF the engine. Then, pull on the ring on the tank Safety Valve to release stored air pressure.

10. Use the air tool as needed.

10

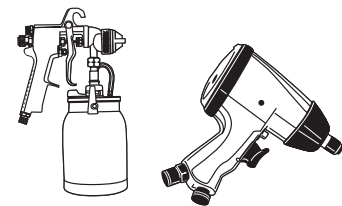

11. After the job is complete, turn OFF the engine.
To stop the engine in an emergency, turn the Engine Switch off.

Under normal conditions, use the following procedure:

- a. Turn the Engine Switch off.
- b. Close the Fuel Valve.

11

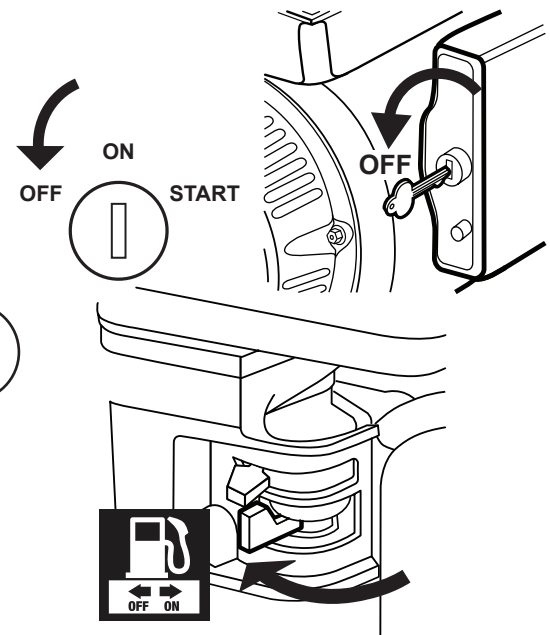

12. Close the in-line Shutoff Valve.

12

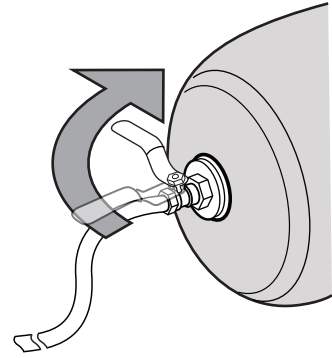

13. Bleed air from the tool then disconnect the tool.

13

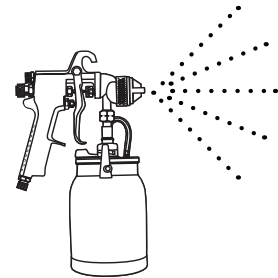

14. Open the Drain Valve at the bottom of the Tank, to release any built-up moisture and the internal tank pressure.

14

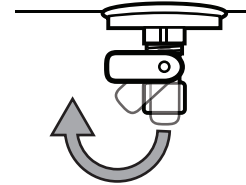

15. Clean, then store the Air Compressor indoors.

⚠ WARNING

TO PREVENT SERIOUS INJURY FROM ACCIDENTAL STARTING:

Turn the Power Switch of the equipment to its “OFF” position, release tank air pressure, wait for the engine to cool, and disconnect the spark plug cap before performing any inspection, maintenance, or cleaning procedures.

TO PREVENT SERIOUS INJURY FROM EQUIPMENT FAILURE:

Do not use damaged equipment. If abnormal noise, vibration, or excess smoking occurs, have the problem corrected before further use.

Follow all service instructions in this manual. The engine may fail critically if not serviced properly.

Maintenance Procedures



Many maintenance procedures, including any not detailed in this manual, will need to be performed by a qualified technician for safety. If you have any doubts about your ability to safely service the equipment or engine, have a qualified technician service the equipment instead.

Compressor Pump Oil Maintenance

Check oil periodically for clarity. Replace oil if it appears milky or if debris is present, or every 6 months, or 100 hours of runtime, whichever comes first. In harsh environments such as high heat or high humidity, you will need to replace the oil more frequently.

Change the compressor oil after the first hour of use to remove any debris.

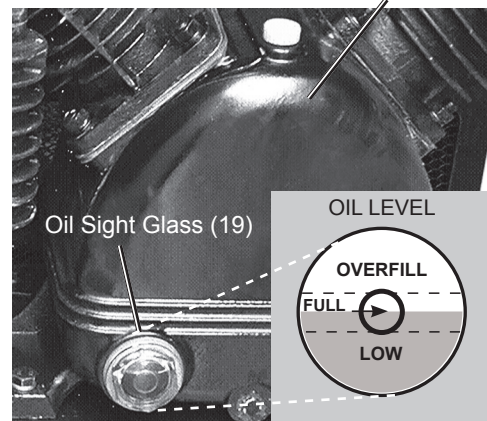

1. The oil level should be at the center of the “full” level on the Oil Sight Glass, as shown above. Add oil as needed to maintain this level. Do not let the oil level go below the center dot (LOW as shown above) and do not overfill the oil so that it is above the center dot (OVERFILL as shown above) on the Oil Sight Glass.
2. To add oil:
 - a. Remove the Oil Plug (17).
 - b. Using a funnel to avoid spills, pour enough oil into the pump Crankcase to reach the “full” level in the Oil Sight Glass.
 - c. Replace the Oil Plug.

Cold Weather Operation

Premium quality 30-weight, non-detergent air compressor oil (sold separately) is recommended for use with this compressor. Start compressor in heated area if outdoor temperatures drop below 32° F. If this is not practical, drain out the old pump oil and use SAE 10W Non-detergent Air Compressor Oil in the pump crankcase instead whenever the compressor’s temperature will fall below 40°. Do not use multi-viscosity oil (such as 10W-30), they leave carbon deposits on pump components and lead to accelerated failure. Heavy operation may require heavier viscosity oil.

3. If uncertain which oil to use for this compressor, please call Harbor Freight Tools customer service at 1-800-444-3353 for assistance.

WARNING! To prevent serious injury from burns: Do not add or change the oil while the compressor is in operation. Allow the compressor to cool before replacing oil.

Changing Oil

To drain the oil from the Pump Crankcase:

- a. Place a container under the Drain Plug.
- b. Remove the Oil Plug to allow air flow into the Pump.
- c. Remove the Drain Plug, allowing the oil to drain into the container.
- d. When the oil is completely drained from the Pump, replace the Drain Plug.
- e. Fill the Pump with new compressor oil to the FULL level on the Oil Sight Glass.
- f. Replace and tighten the Oil Plug.
- g. Discard the old oil according to local, state and federal regulations.

Draining Moisture from the Tank

The Drain Valve is located under the Tank. It must be accessed daily to release all trapped air and moisture from the Tank. This will eliminate condensation which can cause tank corrosion.

To empty the air and condensation:

- a. Make sure the compressor engine is off.
- b. Place a collection pan under the Drain Valve.
- c. Open the Drain Valve by pivoting the lever on the bottom of the Compressor so the lever is in line with the Drain Valve.
- d. When all the pressure is released, close the Drain Valve by pivoting the lever on the bottom of the compressor so that the lever is perpendicular to the Drain Valve.

Air Filter Maintenance

Check the Air Filter weekly to see if it needs replacement. If working in dirty environments, you may need to replace the filter more often. To replace the Air Filter:

- a. Unthread the Wing Nut holding the Air Filter Assembly in place.
- b. Remove the Air Filter Assembly.
- c. Replace with a new Air Filter.
- d. Secure in place with the Wing Nut.

Adjusting Belt Tension

1. Remove the Belt Guard Cover (129) and set it aside.

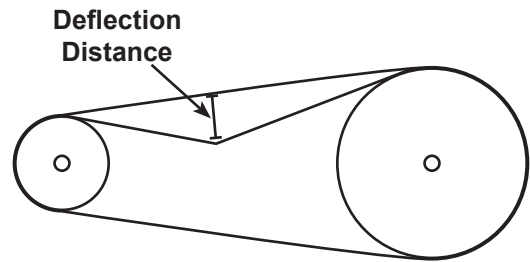

2. Press on the center of the longest span on each belt with moderate finger pressure (4-4.5 lb.). Then measure the deflection distance, the distance that the belt moved. The belt should deflect anywhere from 1/2" to 1".

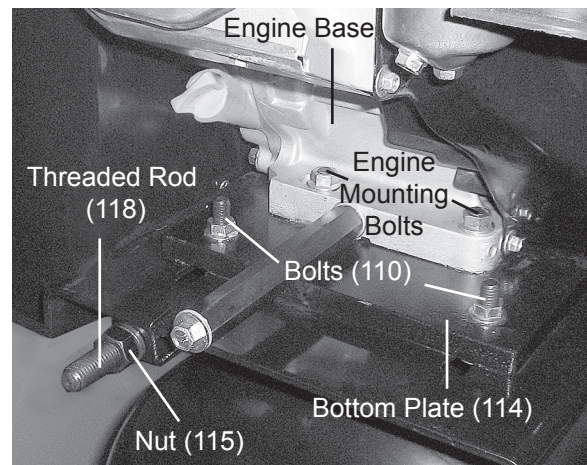

3. **If either belt deflects too much**, tighten belts by loosening the four Bolts (110) on the Bottom Plate (114) and moving the engine away from the other pulley slightly by turning the Nut (115) holding the Threaded Rod (118). Secure engine mounting bolts and retest tension. If either belt is too long to be properly tensioned, both belts must be replaced.
4. **If either belt deflects too little**, loosen belts by loosening the Bolts on the Bottom Plate and moving the engine towards the other pulley slightly by turning the Nut (115) on the Threaded Rod (118). Secure engine mounting bolts and retest tension.
5. Before use, replace belt cover.

Troubleshooting

Problem	Possible Causes	Likely Solutions
Engine will not start (Note: See engine manual for engine specific issues.)	COMPRESSOR SPECIFIC: 1. Pilot Valve closed. 2. Tank already pressurized.	COMPRESSOR SPECIFIC: 1. Open pilot valve before start procedure, close after unit is running. 2. Turn engine on. Compressor will turn on as needed when pressure reaches preset level.
Compressor overheats	1. Incorrect lubrication or not enough lubrication. 2. Worn parts.	1. Lubricate using recommended oil or grease according to directions. 2. Have qualified technician inspect internal mechanism and replace parts as needed.
Severe air leakage	1. Poor air outlet seal. 2. Loose cylinder/cylinder head. 3. Damaged valve or housing. 4. Dirty, worn or damaged valve.	1. Tighten or re-attach using thread seal tape. 2. Tighten cylinder/cylinder head assembly. If cylinder/cylinder head cannot tighten properly, internal parts may be misaligned. 3. Replace damaged components. 4. Clean or replace valve assembly.
Unit stalls	1. Low engine idle. 2. Severely clogged air filter. 3. Improper lubrication. 4. Defective pilot/unloader valve.	1. Qualified technician should increase idle to 2,200±100 RPM by adjusting pressure switch. 2. Replace air filter. 3. Check for proper oil level. 4. Replace pilot valve.
Excessive noise	1. Loose drive pulley or flywheel. 2. Misaligned pulleys. 3. Lack of oil in crankcase. 4. Worn connecting rod. 5. Worn wrist pin bushing. 6. Worn bearings. 7. Loose belts.	1. Loose pulleys are a common cause of "knocking". Tighten appropriate bolts. 2. Align pulleys with straightedge and secure in place. 3. Check for proper oil level. 4. Replace connecting rod. 5. Remove piston assembly and replace necessary parts. 6. Replace bearings and oil. 7. Check for proper belt tension.
Oil in the discharge air	1. Wrong type of oil or low-quality oil. 2. Overheating. 3. Restricted intake air. 4. Worn piston rings. 5. Excessive moisture in the tank.	1. Change oil. Check oil recommendations under EQUIPMENT SET UP, Equipment Oil Fill section of this manual. 2. See above Excessive Noise section. 3. Clean or replace air filter. 4. Replace piston rings. 5. Drain moisture from the tank daily.
Low discharge pressure	1. Air leaks. 2. Leaking valves. 3. Restricted air intake. 4. Blown gaskets. 5. Slipping belts.	1. Listen for escaping air. Apply soap solution to all fittings and connections. Bubbles will appear at points of leakage. Tighten or replace leaking fittings or connections. 2. Remove head and inspect for valve breakage, weak valves, scored valve plate, etc. Replace defective parts and reassemble. Replace head gasket each time the head is removed. 3. Clean or replace air filter element. 4. Replace and gaskets proven faulty on inspection. 5. Tighten Belts (See monthly maintenance.)



Follow all safety precautions whenever diagnosing or servicing the equipment or engine.

PLEASE READ THE FOLLOWING CAREFULLY

THE MANUFACTURER AND/OR DISTRIBUTOR HAS PROVIDED THE PARTS LIST AND ASSEMBLY DIAGRAM IN THIS MANUAL AS A REFERENCE TOOL ONLY. NEITHER THE MANUFACTURER OR DISTRIBUTOR MAKES ANY REPRESENTATION OR WARRANTY OF ANY KIND TO THE BUYER THAT HE OR SHE IS QUALIFIED TO MAKE ANY REPAIRS TO THE PRODUCT, OR THAT HE OR SHE IS QUALIFIED TO REPLACE ANY PARTS OF THE PRODUCT. IN FACT, THE MANUFACTURER AND/OR DISTRIBUTOR EXPRESSLY STATES THAT ALL REPAIRS AND PARTS REPLACEMENTS SHOULD BE UNDERTAKEN BY CERTIFIED AND LICENSED TECHNICIANS, AND NOT BY THE BUYER. THE BUYER ASSUMES ALL RISK AND LIABILITY ARISING OUT OF HIS OR HER REPAIRS TO THE ORIGINAL PRODUCT OR REPLACEMENT PARTS THERETO, OR ARISING OUT OF HIS OR HER INSTALLATION OF REPLACEMENT PARTS THERETO.

Pump Parts List

Part	Description	Qty
1	Bolt M12×55	1
2	Spring Washer 12	1
3	Flat Washer	1
4	Drive Pulley	1
5	Oil Seal Circle	1
6	Flange Plate	1
7	O-ring ø85	1
8	Bearing	1
9	Bolt M12×40	6
10	Oil Breather	1
11	Crank Case End Cover	1
12	Flat Key	1
13	Crankshaft	1
14	Bearing	1
15	Gasket	1
16	Crankcase	1
17	Oil Plug	1
18	Gasket	1
19	Oil Sight Glass	1
20	Drain Oil Bolt	1
21	Second Stage Cylinder Head	1
22	Bolt M12×40	4
23	Spring Washer 12	4
24	Gasket	1
25	Connecting Rod A	1
26	Connecting Rod B	1
27	Bearing Shell	2
28	Spring Washer 10	4
29	Bolt M10×55	2
30	Bushing	1
31	Clip	2
32	Pin	1
33	Piston	1
34	Wiper Ring	2
35	Piston Ring	2
36	Gasket	1
37	Valve	1
38	Aluminum Seal	1
39	Bolt M6×25	4
40	Valve Stop Block	4
41	Spring	8
42	Valve Plate	4
43	Nut M6	4
44	Lock Nut	1
45	Elbow	1
46	Taper Sleeve	1
47	Nut	1

Part	Description	Qty
48	Brass Tube	1
49	Cylinder Head	1
50	Spring Washer	4
51	Bolt M10×65	4
52	Bolt M8×60	1
53	Spring Washer 10	1
54	Nut	1
55	Elbow	1
56	Bolt M8×35	2
57	Spring Washer 8	2
58	Gasket	1
59	Radiator	1
60	Connector	1
61	First Stage Cylinder Head	1
62	Bolt M12×40	4
63	Spring Washer 12	4
64	Gasket	1
65	Bushing	2
66	Connecting Rod A	1
67	Connecting Rod B	1
68	Spring Washer 10	2
69	Bolt M10×55	2
70	Bushing	1
71	Wiper Ring	2
72	Piston	1
73	Pin	1
74	Clip	2
75	Piston Ring	2
76	Gasket	1
77	Valve	1
78	Aluminum Seal	1
79	Bolt M8×30	4
80	Spring	8
81	Restrictor	4
82	Valve Plate	4
83	Nut M8	4
84	Air Filter Assembly	1
85	Cylinder Head	1
86	Spring Washer 12	4
87	Bolt M12×70	4
88	Spring Washer 8	4
89	Bolt M8×70	4
90	Nut	1
91	Pump Safety Valve	1
92	Elbow	1
93	Taper Sleeve	1
94	Nut	1

Pump Assembly Diagram

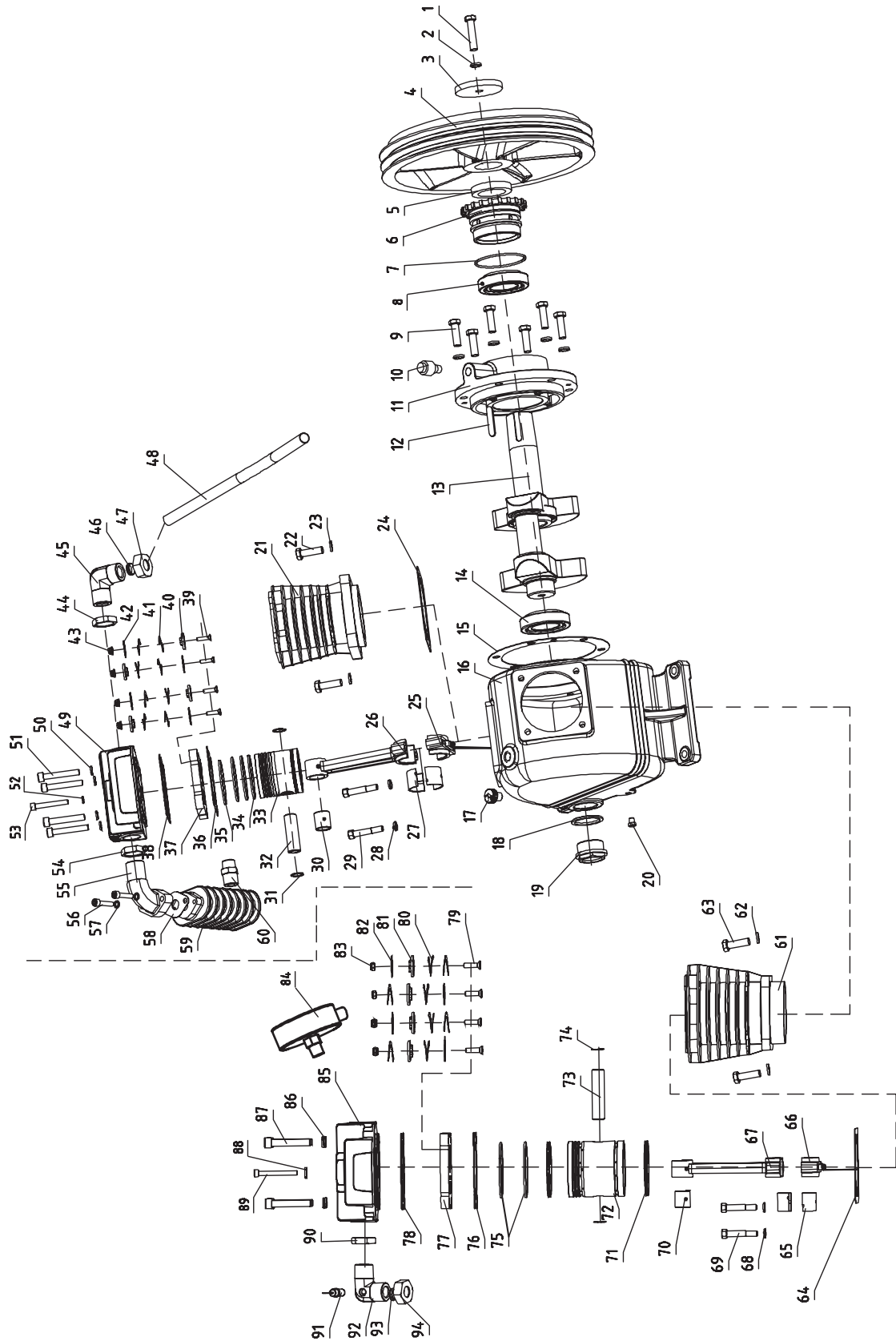

Tank Parts List

Part	Description	Qty
95	Tank	1
96	Connector	1
97	Pressure Gauge	1
98	Tank Safety Valve	1
99	Unloader Valve	1
100	Throttle Control	1
101	Connector	1
102	Taper Sleeve	2
103	Pipe Nut	2
104	Brass Tube	1
105	Air Outlet	1
106	Engine	1
107	Bolt M10×40	4
108	Nut M10	4
109	Bracket	1
110	Bolt M10×50	4
111	Nut M10	4
112	Washer 8	1
113	Bolt M8×20	1
114	Bottom Plate	1
115	Nut M14	1
116	Spring Washer 14	1

Part	Description	Qty
117	Bracket	1
118	Threaded Rod	1
119	Bolt M6×20	1
120	Belt Guard Bracket A	1
121	Belt Guard Frame	1
122	Belt	2
123	Driven Pulley	1
124	Key	1
125	Bushing	1
126	Spring Washer 8	2
127	Bolt M8×30	2
128	Bolt M6×10	11
129	Belt Guard Cover	1
130	Bolt M6×10	1
131	Belt Guard Bracket B	1
132	Bolt M8×16	4
133	Washer 8	4
134	Bolt M12×45	4
135	Spring Washer 12	4
136	Bolt M12	2
137	Drain Valve	1

Tank Assembly Diagram

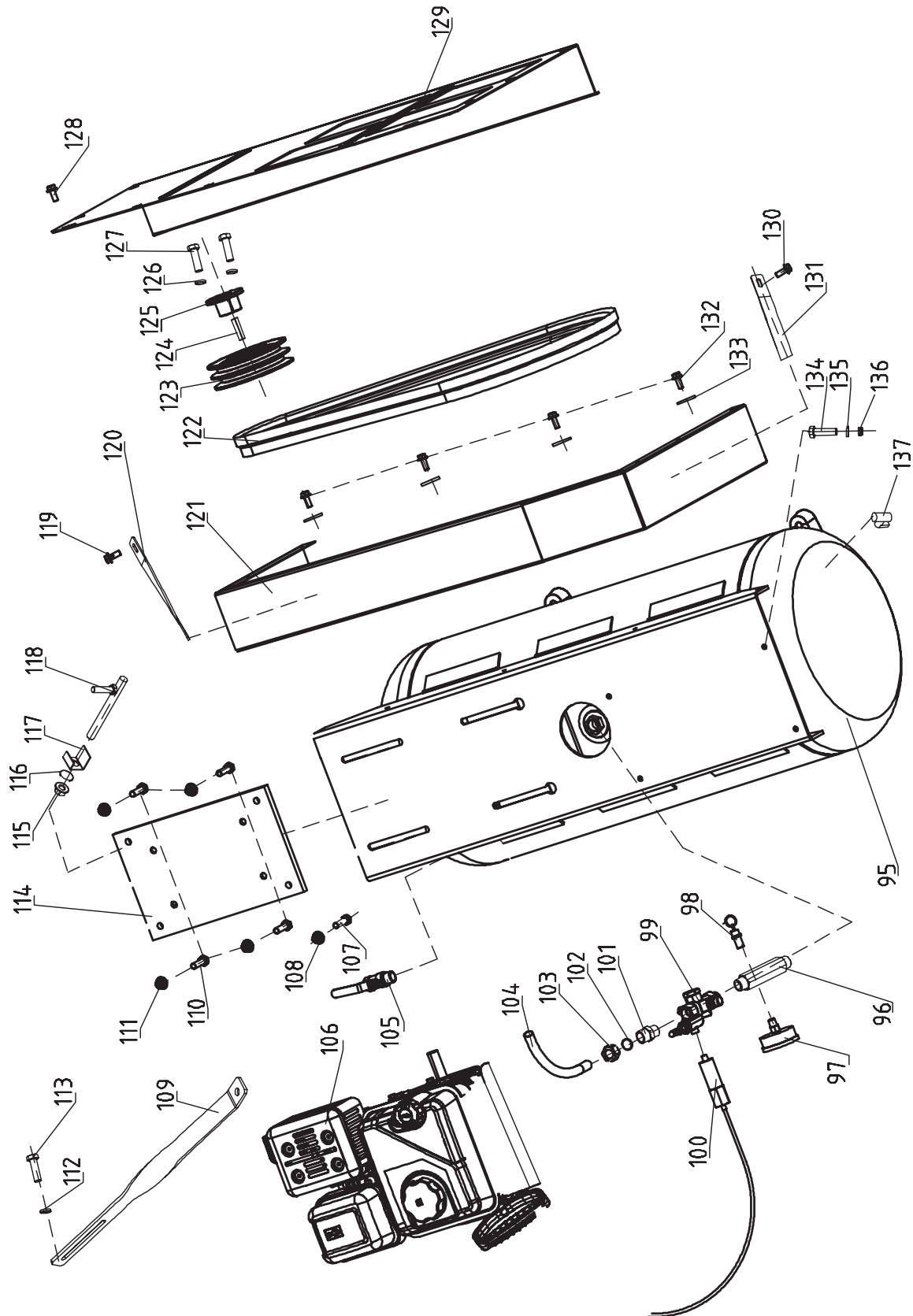

Limited 90 Day Warranty

Harbor Freight Tools Co. makes every effort to assure that its products meet high quality and durability standards, and warrants to the original purchaser that this product is free from defects in materials and workmanship for the period of 90 days from the date of purchase. This warranty does not apply to damage due directly or indirectly, to misuse, abuse, negligence or accidents, repairs or alterations outside our facilities, criminal activity, improper installation, normal wear and tear, or to lack of maintenance. We shall in no event be liable for death, injuries to persons or property, or for incidental, contingent, special or consequential damages arising from the use of our product. Some states do not allow the exclusion or limitation of incidental or consequential damages, so the above limitation of exclusion may not apply to you. THIS WARRANTY IS EXPRESSLY IN LIEU OF ALL OTHER WARRANTIES, EXPRESS OR IMPLIED, INCLUDING THE WARRANTIES OF MERCHANTABILITY AND FITNESS.

To take advantage of this warranty, the product or part must be returned to us with transportation charges prepaid. Proof of purchase date and an explanation of the complaint must accompany the merchandise. If our inspection verifies the defect, we will either repair or replace the product at our election or we may elect to refund the purchase price if we cannot readily and quickly provide you with a replacement. We will return repaired products at our expense, but if we determine there is no defect, or that the defect resulted from causes not within the scope of our warranty, then you must bear the cost of returning the product.

This warranty gives you specific legal rights and you may also have other rights which vary from state to state.

3491 Mission Oaks Blvd. • PO Box 6009 • Camarillo, CA 93011 • (800) 444-3353

Specifications

Pump	Two stage
Air Outlet Size	1/2"- NPT female
Air Pressure	Auto Shut-Off @ 180 PSI Restart @ 140 PSI
Air Tank Capacity	30 Gallons
Air Flow Capacity	18 SCFM @ 90 PSI 19.5 SCFM @ 40 PSI
Oil Capacity	61 oz. (1.8L)
Oil Type	SAE 30W non-detergent Air Compressor Oil (SKU 95048) (Sold separately)
Required Rotation viewed from PTO (power takeoff - the output shaft)	Counterclockwise
Required Engine Idle Speed	2100 RPM ± 100 RPM

Note: Engine specifications are found in the engine manual supplied with this equipment.

CENTRALPNEUMATIC®

3491 Mission Oaks Blvd. • PO Box 6009 • Camarillo, CA 93011 • (800) 444-3353

www.harborfreight.com

PREDATOR™ E N G I N E S

212, 346 and 420 cc Horizontal Engines

68120/68121 212cc Horizontal Engine

68136 346cc Horizontal Engine

68306 420cc Horizontal Engine

⚠ DANGER

Using an engine indoors CAN KILL YOU
IN MINUTES.

Engine exhaust contains carbon monoxide.
This is a poison you cannot see or smell.



NEVER use inside
a home or garage,
EVEN IF doors and
windows are open.



Only use **OUTSIDE**
and far away from
windows, doors,
and vents.



When unpacking, make sure that the product is intact and undamaged.
If any parts are missing or broken, please call 1-800-520-0882 as soon as possible.

Record Product's Serial Number Here: _____
(See Serial Number Location on page 6.)

Note: If product has no serial number, record month and year of purchase instead.

Note: Some parts are listed and shown for illustration purposes only, and are not available individually as replacement parts.

Visit our website at: <http://www.harborfreight.com>
Email our engine tech support at: predator@harborfreight.com

Copyright© 2010 by Harbor Freight Tools®. All rights reserved. No portion of this manual or any artwork contained herein may be reproduced in any shape or form without the express written consent of Harbor Freight Tools. Diagrams within this manual may not be drawn proportionally. Due to continuing improvements, actual product may differ slightly from the product described herein. Tools required for assembly and service may not be included.

Specifications

Description		68120, 68121	68136	68306
Displacement		212cc	346cc	420cc
Engine Type		Horizontal Single Cylinder 4 stroke OHV		
Cooling System		Forced air cooled		
Fuel	Type	87+ octane unleaded gasoline		
	Capacity	1 Gallon	1 Gallon	1 Gallon
Engine Oil	Type SAE	10W-30 above 32° F 5W30 at 32° F or below		
	Capacity	0.5 Quart	1.16 Quart	1.16 Quart
Run Time @ 50% Load with full tank		3 hr.		
Sound Level at 22 feet		104 dB	108 dB	108 dB
Bore x Stroke		70 mm x 55 mm	83 mm x 64 mm	90 mm x 66 mm
Compression Ratio		8.5:1		
Rotation viewed from PTO (power takeoff - the output shaft)		Counterclockwise		
Shaft	Shaft	3/4" x 2.41"	1" x 3.48"	1" x 3.48"
	Keyway	3/16" (4.76 mm)	1/4" (6.35 mm)	1/4" (6.35 mm)
	End Tapped	5/16" - 24 UNF	3/8" - 24	3/8" - 24
Spark Plug	Type	NGK® BP-6ES NHSP® / Torch® F6TC	NHSP® / Torch® F6TC	NHSP® / Torch® F6TC
	Gap	0.7 - 0.8 mm		
Valve Clearance	Intake	0.10 - 0.15 mm		
	Exhaust	0.15 - 0.20 mm		
Speed	Idle	1,800 ± 50 RPM		

Save This Manual

Keep this manual for the safety warnings and precautions, assembly, operating, inspection, maintenance and cleaning procedures. Write the product's serial number in the back of the manual near the assembly diagram (or month and year of purchase if product has no number). Keep this manual and the receipt in a safe and dry place for future reference.

Safety Warnings

In this manual, on the labeling, and all other information provided with this product:



This is the safety alert symbol. It is used to alert you to potential personal injury hazards. Obey all safety messages that follow this symbol to avoid possible injury or death.

! DANGER

DANGER indicates a hazardous situation which, if not avoided, will result in death or serious injury.

! WARNING

WARNING indicates a hazardous situation which, if not avoided, could result in death or serious injury.

! CAUTION

CAUTION, used with the safety alert symbol, indicates a hazardous situation which, if not avoided, could result in minor or moderate injury.







NOTICE

NOTICE is used to address practices not related to personal injury.

CAUTION

CAUTION, without the safety alert symbol, is used to address practices not related to personal injury.

Symbol Definitions

Symbol	Property or Statement
RPM	Revolutions Per Minute
HP	Horsepower
	WARNING marking concerning Risk of Eye Injury. Wear ANSI-approved safety goggles with side shields.
	Read the manual before set-up and/or use.
	WARNING marking concerning Risk of Hearing Loss. Wear hearing protection.
	WARNING marking concerning Risk of Respiratory Injury. Operate engine OUTSIDE and far away from windows, doors, and vents.
	WARNING marking concerning Risk of Fire while handling fuel. Do not smoke while handling fuel.
	WARNING marking concerning Risk of Fire. Do not refuel while operating. Keep flammable objects away from engine.



WARNING! Read all instructions.

Failure to follow all instructions listed below may result in fire, serious injury and/or DEATH.

The warnings and precautions discussed in this manual cannot cover all possible conditions and situations that may occur. It must be understood by the operator that common sense and caution are factors which cannot be built into this product, but must be supplied by the operator.

SAVE THESE INSTRUCTIONS

Set up Precautions

1. Gasoline fuel and fumes are flammable, and potentially explosive. Use proper fuel storage and handling procedures. Do not store fuel or other flammable materials nearby.
2. Have multiple ABC class fire extinguishers nearby.
3. Operation of this equipment may create sparks that can start fires around dry vegetation. A spark arrestor may be required. The operator should contact local fire agencies for laws or regulations relating to fire prevention requirements.
4. Set up and use only on a flat, level, well-ventilated surface.
5. Wear ANSI-approved safety goggles, heavy-duty work gloves, and dust mask/respirator during set up.
6. Use only lubricants and fuel recommended in the Specifications chart of this manual.

Operating Precautions

1.  **CARBON MONOXIDE HAZARD**
Using an engine indoors CAN KILL YOU IN MINUTES.
Engine exhaust contains carbon monoxide. This is a poison you cannot see or smell.

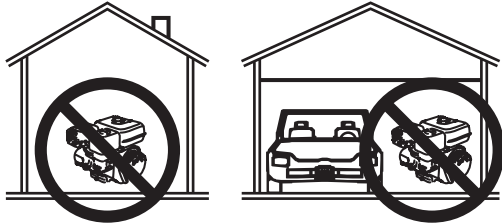

NEVER use inside a home or garage, EVEN IF doors and windows are open.

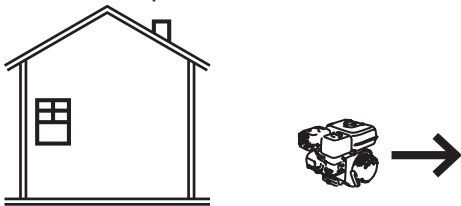

Only use OUTSIDE and far away from windows, doors, and vents.

2. Keep children away from the equipment, especially while it is operating.
3. Keep all spectators at least six feet from the Engine during operation.
4. Fire Hazard! Do not fill gas tank while engine is running. Do not operate if gasoline has been spilled. Clean spilled gasoline before starting engine. Do not operate near pilot light or open flame.
5. Do not touch engine during use. Let engine cool down after use.

6. Never store fuel or other flammable materials near the engine.
7. Only use a suitable means of transport and lifting devices with sufficient weight bearing capacity when transporting the Engine.
8. Secure the Engine on transport vehicles to prevent the tool from rolling, slipping, and tilting.
9. Industrial applications must follow OSHA requirements.
10. Do not leave the equipment unattended when it is running. Turn off the equipment (and remove safety keys, if available) before leaving the work area.
11. Engine can produce high noise levels. Prolonged exposure to noise levels above 85 dBA is hazardous to hearing. Always wear ear protection when operating or working around the gas engine while it is operating.
12. Wear ANSI-approved safety glasses, hearing protection, and NIOSH-approved dust mask/respirator under a full face shield along with steel-toed work boots during use.
13. People with pacemakers should consult their physician(s) before use. Electromagnetic fields in close proximity to a heart pacemaker could cause pacemaker interference or pacemaker failure. Caution is necessary when near the engine's magneto or recoil starter.
14. Use only accessories that are recommended by Harbor Freight Tools for your model. Accessories that may be suitable for one piece of equipment may become hazardous when used on another piece of equipment.
15. Do not operate in explosive atmospheres, such as in the presence of flammable liquids, gases, or dust. Gasoline-powered engines may ignite the dust or fumes.
16. Stay alert, watch what you are doing and use common sense when operating this piece of equipment. Do not use this piece of equipment while tired or under the influence of drugs, alcohol or medication.
17. Do not overreach. Keep proper footing and balance at all times. This enables better control of the equipment in unexpected situations.
18. Use this equipment with both hands only. Using equipment with only one hand can easily result in loss of control.
19. Dress properly. Do not wear loose clothing or jewelry. Keep hair, clothing and gloves away from moving parts. Loose clothes, jewelry or long hair can be caught in moving parts.
20. Parts, especially exhaust system components, get very hot during use. Stay clear of hot parts.
21. Do not cover the engine or equipment during operation.
22. Keep the equipment, engine, and surrounding area clean at all times.

23. Use the equipment, accessories, etc., in accordance with these instructions and in the manner intended for the particular type of equipment, taking into account the working conditions and the work to be performed. Use of the equipment for operations different from those intended could result in a hazardous situation.
 24. Do not operate the equipment with known leaks in the engine's fuel system.
 25. This product contains or, when used, produces a chemical known to the State of California to cause cancer and birth defects or other reproductive harm. (California Health & Safety Code § 25249.5, *et seq.*)
 26. When spills of fuel or oil occur, they must be cleaned up immediately. Dispose of fluids and cleaning materials as per any local, state, or federal codes and regulations. Store oil rags in a bottom-ventilated, covered, metal container.
 27. Keep hands and feet away from moving parts. Do not reach over or across equipment while operating.
 28. Before use, check for misalignment or binding of moving parts, breakage of parts, and any other condition that may affect the equipment's operation. **If damaged, have the equipment serviced before using.** Many accidents are caused by poorly maintained equipment.
 29. Use the correct equipment for the application. Do not modify the equipment and do not use the equipment for a purpose for which it is not intended.
4. Wear ANSI-approved safety goggles, heavy-duty work gloves, and dust mask/respirator during service.
 5. Maintain labels and nameplates on the equipment. These carry important information. If unreadable or missing, contact Harbor Freight Tools for a replacement.
 6. Have the equipment serviced by a qualified repair person using only identical replacement parts. This will ensure that the safety of the equipment is maintained. Do not attempt any service or maintenance procedures not explained in this manual or any procedures that you are uncertain about your ability to perform safely or correctly.
 7. Store equipment out of the reach of children.
 8. Follow scheduled engine and equipment maintenance.

Refueling:

1. Do not smoke, or allow sparks, flames, or other sources of ignition around the equipment, especially when refuelling.
2. Do not refill the fuel tank while the engine is running or hot.
3. **TO PREVENT FUEL LEAKAGE AND FIRE HAZARD, do not fill fuel above the bottom of fuel strainer for the 68121, 212cc engine.**

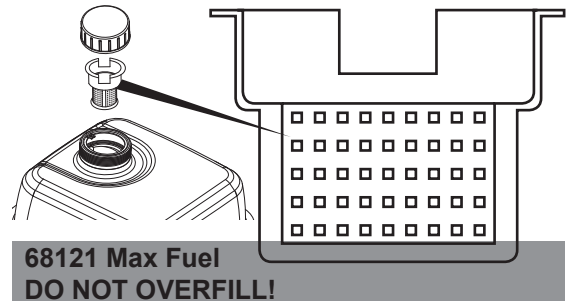

Service Precautions

1. **Before service, maintenance, or cleaning:**
 - a. Turn the engine switch to its "OFF" position.
 - b. Allow the engine to completely cool.
 - c. Then, remove the spark plug cap from the spark plug.
2. Keep all safety guards in place and in proper working order. Safety guards include muffler, air cleaner, mechanical guards, and heat shields, among other guards.
3. **Do not alter or adjust any part of the equipment or its engine that is sealed by the manufacturer or distributor. Only a qualified service technician may adjust parts that may increase or decrease governed engine speed.**

4. Do not fill fuel tank to the top. Leave a little room for the fuel to expand as needed.
5. Refuel in a well-ventilated area only.
6. Wipe up any spilled fuel and allow excess to evaporate before starting engine. **To prevent FIRE, do not start the engine while the smell of fuel hangs in the air.**

 **SAVE THESE INSTRUCTIONS.**

Engine Controls

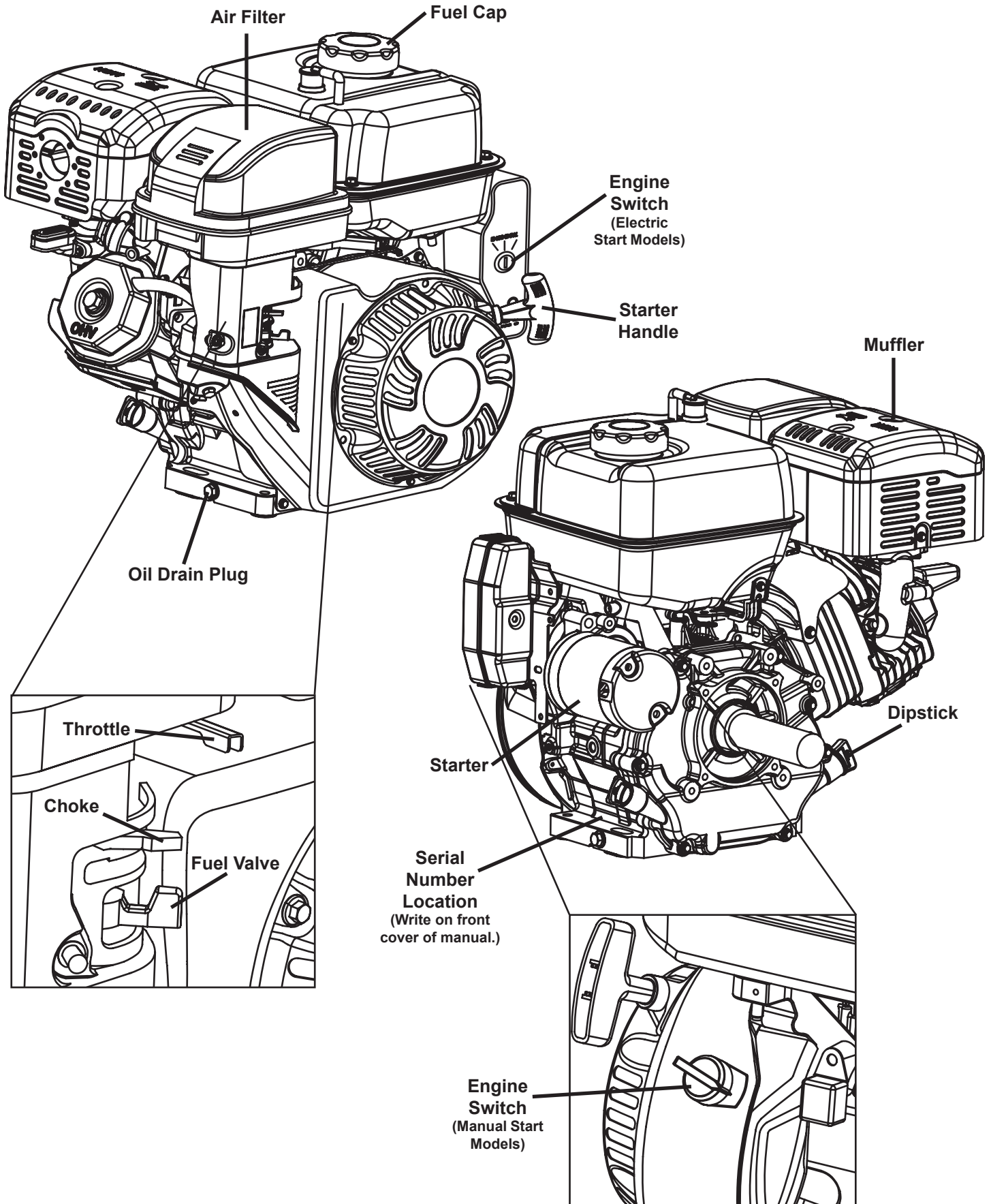

Set Up

Model 68120: The emission control system for this engine is warranted for standards set by the U.S. Environmental Protection Agency. For warranty information, refer to the last pages of this manual.

Models 68306, 68121, and 68136: The emission control system for this Generator's Engine is warranted for standards set by the U.S. Environmental Protection Agency and by the California Air Resources Board (also known as CARB). For warranty information, refer to the last pages of this manual.



Read the **ENTIRE IMPORTANT SAFETY INFORMATION** section at the beginning of this manual including all text under subheadings therein before set up or use of this product.

⚠ WARNING

TO PREVENT SERIOUS INJURY:

Operate only with proper spark arrestor installed.

Operation of this equipment may create sparks that can start fires around dry vegetation.

A spark arrestor may be required.

The operator should contact local fire agencies for laws or regulations relating to fire prevention requirements.

At high altitudes, the engine's carburetor, governor (if so equipped), and any other parts that control the fuel-air ratio will need to be adjusted by a qualified mechanic to allow efficient high-altitude use and to prevent damage to the engine and any other devices used with this product.

WARNING! DO NOT INSTALL THIS ENGINE ON A VEHICLE.

Battery Setup Instructions

1. Place a fully charged, lead-acid 12 V, 36+ Ah battery (not included) in a stable, flat location near the engine.
2. Only use cables sized to match their length according to the following chart:

Cable Gauge (lower gauge numbers mean thicker cables)	Maximum Cable Length
6	5'
4	7'
2	12'

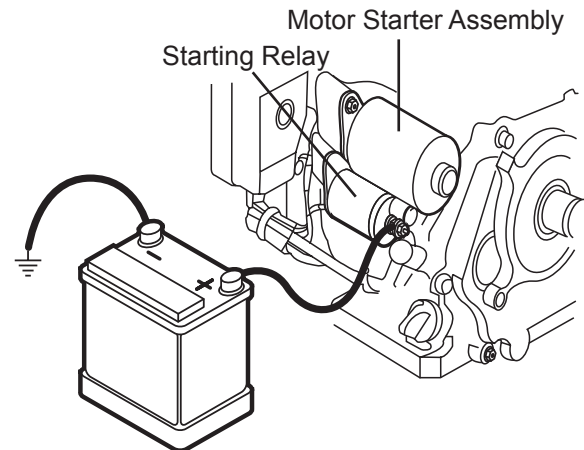

3. Attach the positive cable from the positive battery terminal to the Positive Terminal on the starter, shown above. Connect cable securely to prevent disconnection and short circuits.
4. Attach the negative cable to the negative battery terminal.
5. Connect the negative cable securely to one of the engine mounting bolts.

Operation



Read the **ENTIRE IMPORTANT SAFETY INFORMATION** section at the beginning of this manual including all text under subheadings therein before set up or use of this product.

Pre-Start Checks

Inspect engine and equipment looking for damaged, loose, and missing parts before set up and starting. If any problems are found, do not use equipment until fixed properly.

Checking and Filling Engine Oil

CAUTION! Your Warranty is VOID if the engine's crankcase is not properly filled with oil before each use. Before each use, check the oil level. Do not run the engine with low or no engine oil. Running the engine with no or low engine oil WILL permanently damage the engine.

1. Make sure the engine is stopped and is level.
2. Close the Fuel Valve.
3. Clean the top of the Dipstick and the area around it. Remove the Dipstick by threading it counterclockwise, and wipe it off with a clean lint free rag.

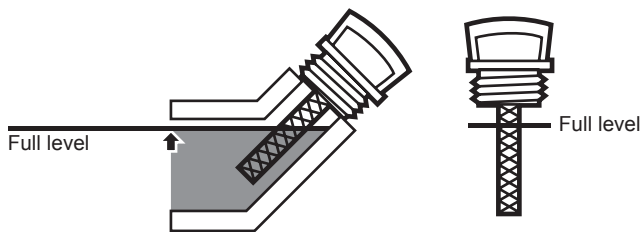

4. Reinsert the Dipstick without threading it in and remove it to check the oil level. The oil level should be up to the full level as shown above.
5. If the oil level is at or below the low mark add the appropriate type of oil until the oil level is at the proper level. SAE 10W-30 oil is recommended for general use. (The SAE Viscosity Grade chart on page 14 in the Service section shows other viscosities to use in different average temperatures.)
6. Thread the dipstick back in clockwise.

CAUTION! Do not run the engine with too little oil. The engine will be permanently damaged.

Checking and Filling Fuel



WARNING! TO PREVENT SERIOUS INJURY FROM FIRE:

Fill the fuel tank in a well-ventilated area away from ignition sources. If the engine is hot from use, shut the engine off and wait for it to cool before adding fuel. Do not smoke.

1. Clean the Fuel Cap and the area around it.
2. Unscrew and remove the Fuel Cap.
3. If needed, fill the Fuel Tank to about 1 inch under the fill neck of the Fuel Tank with 87 octane or higher unleaded gasoline.

Note: Do not use gasoline containing more than 10% ethanol (E10). Do not use E85 ethanol.

Note: Do not use gasoline that has been stored in a metal fuel container or a dirty fuel container. It can cause particles to enter the carburetor, affecting engine performance and/or causing damage.

4. Then replace the Fuel Cap.
5. Wipe up any spilled fuel and allow excess to evaporate before starting engine. To prevent FIRE, do not start the engine while the smell of fuel hangs in the air.

Starting the Engine

Before Starting the Engine



Before starting the engine:

- a. Follow the Set Up Instructions in the equipment manual to prepare the equipment.
- b. Inspect the equipment and engine.
- c. Fill the engine with the proper amount and type of both fuel and oil.
- d. Read the Equipment Operation section in the equipment manual.

Manual Start

1. To start a cold engine, move the Choke to the CHOKE position.
To restart a warm engine, leave the Choke in the RUN position.

1

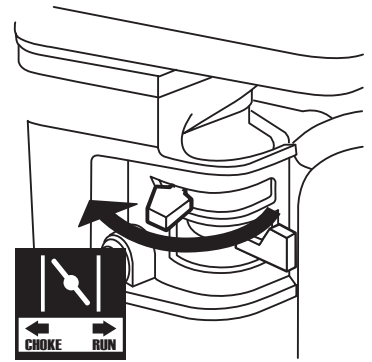

2. Open the Fuel Valve.

2

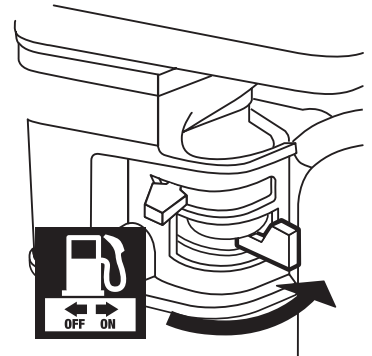

3. Slide the Throttle or Speed Control Lever to 1/3 away from the SLOW position (the "turtle").

Note: Some tools have a Speed Control Lever located elsewhere on the tool which functions the same as the Throttle. Use the Speed Control Lever in place of the Throttle when the tool is so equipped.

3



4. Turn the Engine Switch on.

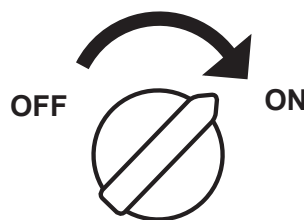

4

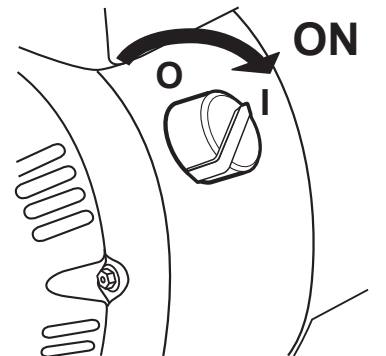

5. Grip the Starter Handle of the Engine loosely and pull it slowly several times to allow the gasoline to flow into the Engine's carburetor. Then pull the Starter Handle gently until resistance is felt. Allow Cable to retract fully and then pull it quickly. Repeat until the engine starts.

5

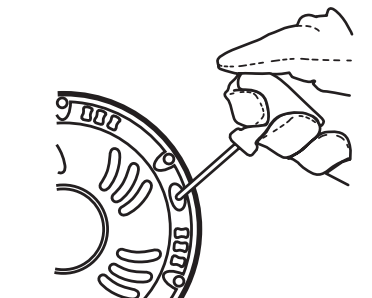

6. Allow the Engine to run for several seconds. Then, if the Choke lever is in the CHOKE position, move the Choke Lever very slowly to its RUN position.

NOTE: Moving the Choke Lever too fast could stall the engine.

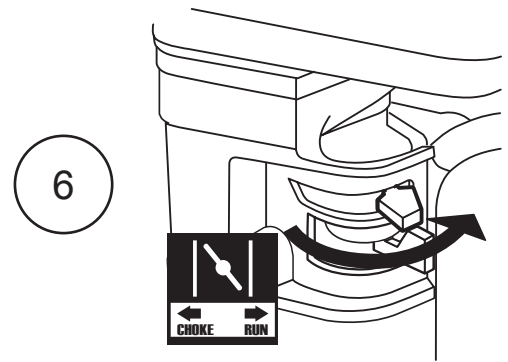

IMPORTANT: Allow the engine to run at no load for five minutes with no load after each start-up so that the engine can stabilize.

7. Adjust the Throttle as needed.
8. **Break-in Period:**
 - a. Breaking-in the engine will help to ensure proper equipment and engine operation.
 - b. The operational break-in period will last about 3 hours of use. During this period:
 - Do not apply a heavy load to the equipment.
 - Do not operate the engine at its maximum speed.
 - c. The maintenance break-in period will last about 20 hours of use. After this period:
 - Change the engine oil.

Under normal operating conditions subsequent maintenance follows the schedule explained in the MAINTENANCE AND SERVICING section.

Stopping the Engine

1. To stop the engine in an emergency, turn the Engine Switch off.
2. Under normal conditions, use the following procedure:
 - a. Slide the Throttle or Speed Control Lever to SLOW (the "turtle").
 - b. Turn the Engine Switch off.
 - c. Close the Fuel Valve.

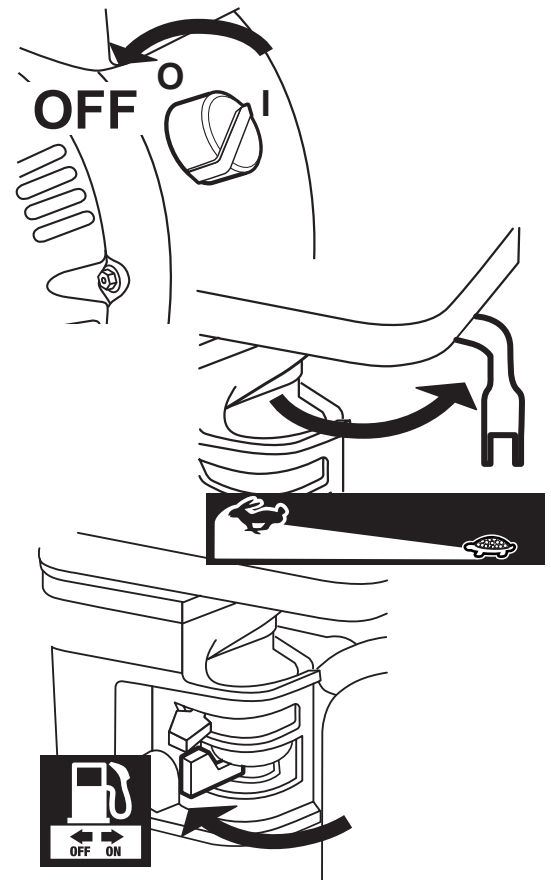

Electric Start (if equipped)

1. To start a cold engine, move the Choke to the CHOKE position.
To restart a warm engine, leave the Choke in the RUN position.

1

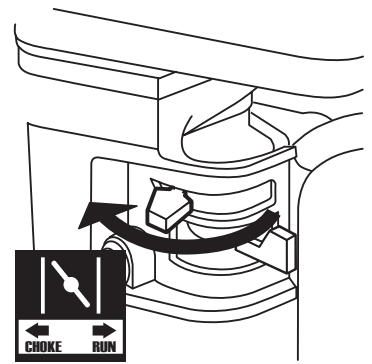

2. Open the Fuel Valve.

2

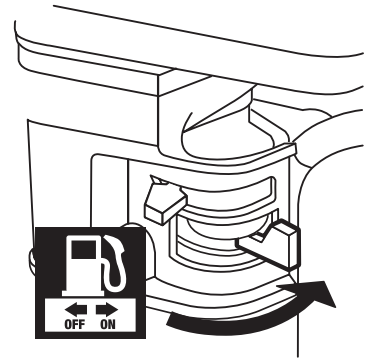

3. Slide the Throttle or Speed Control Lever to 1/3 away from the SLOW position (the "turtle").

Note: Some tools have a Speed Control Lever located elsewhere on the tool which functions the same as the Throttle. Use the Speed Control Lever in place of the Throttle when the tool is so equipped.

3



4. Turn the Engine Switch to START.

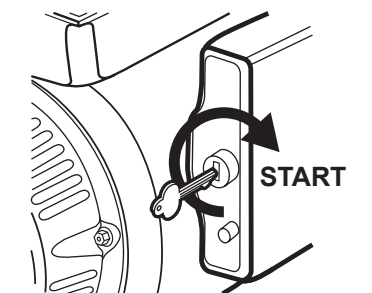
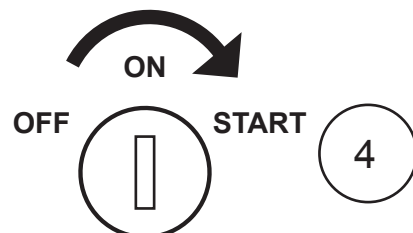

5. Allow the Engine to run for several seconds. Then, if the Choke lever is in the CHOKE position, move the Choke Lever very slowly to its RUN position.

NOTE: Moving the Choke Lever too fast could stall the engine.

IMPORTANT: Allow the engine to run at no load for five minutes with no load after each start-up so that the engine can stabilize.

6. Adjust the Throttle as needed.
7. **Break-in Period:**
 - a. Breaking-in the engine will help to ensure proper equipment and engine operation.
 - b. The operational break-in period will last about 3 hours of use. During this period:
 - Do not apply a heavy load to the equipment.
 - Do not operate the engine at its maximum speed.
 - c. The maintenance break-in period will last about 20 hours of use. After this period:
 - Change the engine oil.

Under normal operating conditions subsequent maintenance follows the schedule explained in the MAINTENANCE AND SERVICING section.

Stopping the Engine

1. To stop the engine in an emergency, turn the Engine Switch off.
2. Under normal conditions, use the following procedure:
 - a. Slide the Throttle or Speed Control Lever to SLOW (the “turtle”).
 - b. Turn the Engine Switch off.
 - c. Close the Fuel Valve.

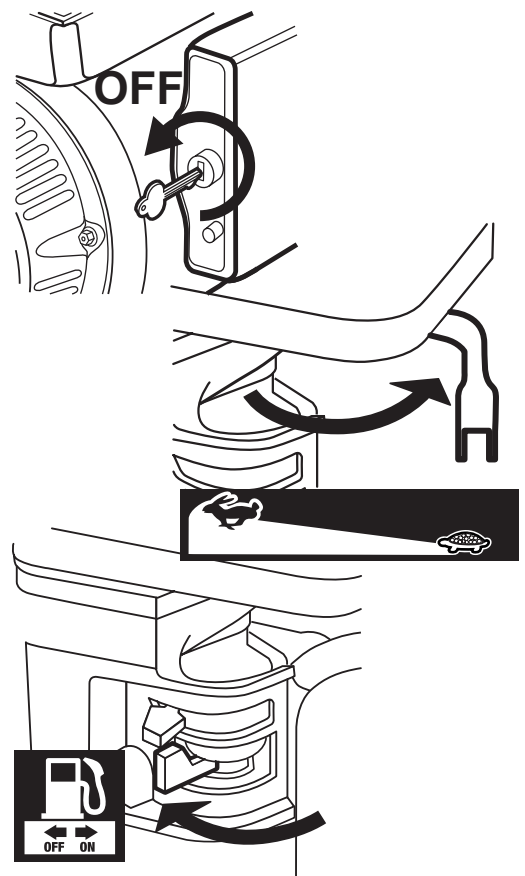
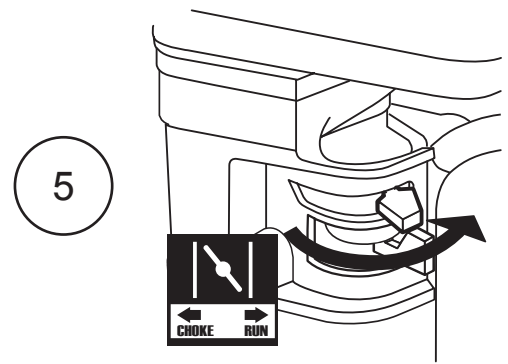

⚠ WARNING

TO PREVENT SERIOUS INJURY FROM ACCIDENTAL STARTING:

Turn the Power Switch of the equipment to its “OFF” position, wait for the engine to cool, and disconnect the spark plug cap before performing any inspection, maintenance, or cleaning procedures.

TO PREVENT SERIOUS INJURY FROM EQUIPMENT FAILURE:

Do not use damaged equipment. If abnormal noise, vibration, or excess smoking occurs, have the problem corrected before further use.

Follow all service instructions in this manual. The engine may fail critically if not serviced properly.



Many maintenance procedures, including any not detailed in this manual, will need to be performed by a qualified technician for safety. If you have any doubts about your ability to safely service the equipment or engine, have a qualified technician service the equipment instead.

Cleaning, Maintenance, and Lubrication Schedule

Note: This maintenance schedule is intended solely as a general guide. If performance decreases or if equipment operates unusually, check systems immediately. The maintenance needs of each piece of equipment will differ depending on factors such as duty cycle, temperature, air quality, fuel quality, and other factors.

Note: The following procedures are in addition to the regular checks and maintenance explained as part of the regular operation of the engine and equipment.

Procedure	Before Each Use	Monthly or every 20 hr. of use	Every 3 mo. or 50 hr. of use	Every 6 mo. or 100 hr. of use	Yearly or every 300 hr. of use	Every 2 Years
Brush off outside of engine	✓	✓	✓	✓	✓	✓
Check engine oil level	✓	✓	✓	✓	✓	✓
Check air cleaner	✓		✓	✓	✓	✓
Check deposit cup	✓			✓	✓	✓
Change engine oil		✓		✓	✓	✓
Clean/replace air cleaner			✓*	✓	✓	✓
Check and clean spark plug				✓	✓	✓
1. Check/adjust idle speed 2. Check/adjust valve clearance 3. Clean fuel tank, strainer and carburetor 4. Clean carbon build-up from combustion chamber					✓**	✓**
Replace fuel line if necessary						✓**

*Service more frequently when used in dusty areas.

**These items should be serviced by a qualified technician.

Checking and Filling Fuel



⚠ WARNING! TO PREVENT SERIOUS INJURY FROM FIRE:

Fill the fuel tank in a well-ventilated area away from ignition sources. If the engine is hot from use, shut the engine off and wait for it to cool before adding fuel. Do not smoke.

1. Clean the Fuel Cap and the area around it.
2. Unscrew and remove the Fuel Cap.
3. If needed, fill the Fuel Tank to about 1 inch under the fill neck of the Fuel Tank with 87 octane or higher unleaded gasoline. For the 68121, fill to the bottom of the fuel strainer ONLY, see below.

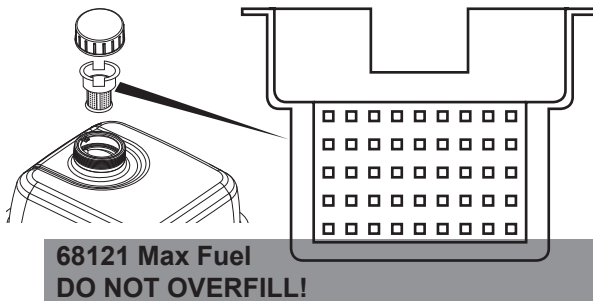

⚠ WARNING! TO PREVENT FUEL LEAKAGE AND FIRE HAZARD, do not fill fuel above the bottom of fuel strainer for the 68121, 212cc engine.

Note: Do not use gasoline containing more than 10% ethanol (E10). Do not use E85 ethanol.

Note: Do not use gasoline that has been stored in a metal fuel container or a dirty fuel container. It can cause particles to enter the carburetor, affecting engine performance and/or causing damage.

4. Then replace the Fuel Cap.
5. Wipe up any spilled fuel and allow excess to evaporate before starting engine. To prevent FIRE, do not start the engine while the smell of fuel hangs in the air.

Engine Oil Change

⚠ CAUTION! Oil is very hot during operation and can cause burns. Wait for engine to cool before changing oil.

1. Make sure the engine is stopped and is level.
2. Close the Fuel Valve.
3. Place a drain pan (not included) underneath the crankcase's drain plug.
4. Remove the drain plug and, if possible, tilt the crankcase slightly to help drain the oil out. Recycle used oil.
5. Replace the drain plug and tighten it.
6. Clean the top of the Dipstick and the area around it. Remove the Dipstick by threading it counterclockwise, and wipe it off with a clean lint free rag.

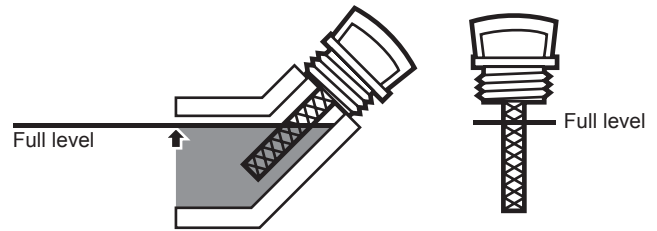

7. Add the appropriate type of oil until the oil level is at the full level. SAE 10W-30 oil is recommended for general use. The SAE Viscosity Grade chart shows other viscosities to use in different average temperatures.

SAE Viscosity Grades

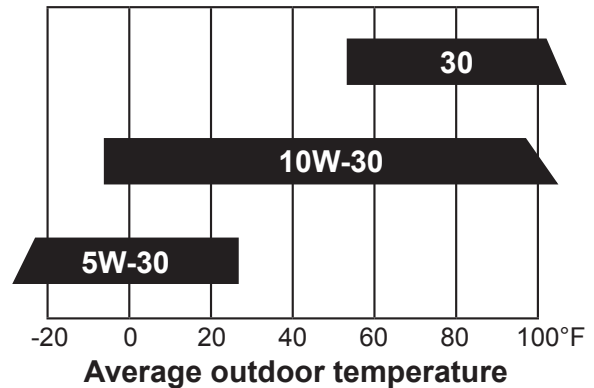

8. Thread the dipstick back in clockwise.

CAUTION! Do not run the engine with too little oil. The engine will be permanently damaged.

Air Filter Element Maintenance

1. Remove the air filter cover and the air filter elements and check for dirt. Clean or replace as described below.
2. **Cleaning:**
 - For "paper" filter elements:
To prevent injury from dust and debris, wear ANSI-approved safety goggles, NIOSH-approved dust mask/respirator, and heavy-duty work gloves. In a well-ventilated area away from bystanders, use pressurized air to blow dust out of the air filter. If this does not get the filter clean, replace it.
 - For foam filter elements:
Wash the element in warm water and mild detergent several times. Rinse. Squeeze out excess water and allow it to dry completely. Soak the filter in lightweight oil briefly, then squeeze out the excess oil.
3. Install the new filter or the cleaned filter. Secure the Air Cleaner Cover before use.

Spark Plug Maintenance

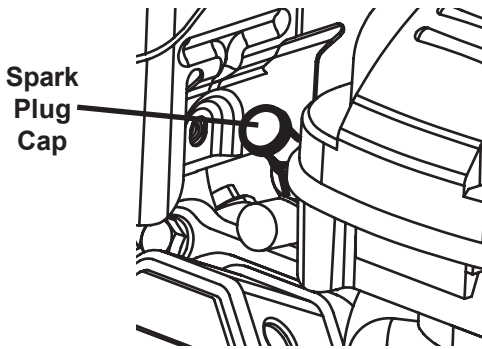

1. Disconnect spark plug cap from end of plug. Clean out debris from around spark plug.
2. Using a spark plug wrench, remove the spark plug.
3. Inspect the spark plug:
If the electrode is oily, clean it using a clean, dry rag. If the electrode has deposits on it, polish it using emery paper. If the white insulator is cracked or chipped, the spark plug needs to be replaced.

Recommended Spark Plugs			
Brand	68120, 68121	68136	68306
	NGK®	BP-6ES	
NHSP®/TORCH®	F6TC	F6TC	F6TC

NOTICE: Using an incorrect spark plug may damage the engine.

4. When installing a new spark plug, adjust the plug's gap to the specification on the Technical Specifications chart. Do not pry against the electrode, the spark plug can be damaged.
5. Install the new spark plug or the cleaned spark plug into the engine. Gasket-style: Finger-tighten until the gasket contacts the cylinder head, then about 1/2-2/3 turn more.
Non-gasket-style: Finger-tighten until the plug contacts the head, then about 1/16 turn more.

NOTICE: Tighten the spark plug properly. If loose, the spark plug will cause the engine to overheat. If overtightened, the threads in the engine block will be damaged.

6. Apply dielectric spark plug boot protector (not included) to the end of the spark plug and reattach the wire securely.

Storage

When the equipment is to remain idle for longer than 20 days, prepare the engine for storage as follows:

1. CLEANING:

Wait for engine to cool, then clean engine with dry cloth. **NOTICE: Do not clean using water.** The water will gradually enter the engine and cause rust damage.
Apply a thin coat of rust preventive oil to all metal parts.

2. FUEL:



WARNING! TO PREVENT SERIOUS INJURY FROM FIRE:

Drain the fuel tank in a well-ventilated area away from ignition sources. If the engine is hot from use, shut the engine off and wait for it to cool before draining fuel. Do not smoke.

- a. Place a funnel leading to a proper gasoline container below the carburetor.

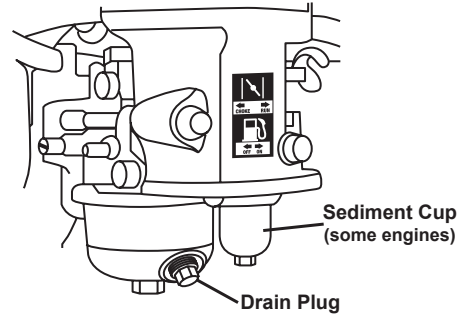

- b. Remove the drain bolt from the bottom of the carburetor bowl and allow the fuel to drain.
- c. Remove the small sediment cup next to the bowl and allow the fuel to drain from there as well.
- d. Open the fuel valve. After all fuel has drained, reinstall the drain bolt and sediment cup (if equipped). Tighten securely.

3. LUBRICATION:

- a. Change engine oil.
- b. Clean out area around spark plug. Remove spark plug and pour one tablespoon of engine oil into cylinder through spark plug hole.
- c. Replace spark plug, but leave spark plug cap disconnected.
- d. Pull Starter Handle to distribute oil in cylinder. Stop after one or two revolutions when you feel the piston start the compression stroke (when you start to feel resistance).

4. BATTERY:

Disconnect battery cables (if equipped). Recharge batteries monthly while in storage.

5. STORAGE AREA:

Cover and store in a dry, level, well-ventilated area out of reach of children. Storage area should also be away from ignition sources, such as water heaters, clothes dryers, and furnaces.

6. AFTER STORAGE:

Before starting the engine after storage, keep in mind that untreated gasoline will deteriorate quickly. Drain the fuel tank and change to fresh fuel if untreated gasoline has been sitting for a month, if treated gasoline has been sitting beyond the fuel stabilizer's recommended time period, or if the engine does not start.

Troubleshooting

Problem	Possible Causes	Probable Solutions
Engine will not start	<p>FUEL RELATED:</p> <ol style="list-style-type: none"> 1. No fuel in tank or fuel valve closed. 2. Choke not in CHOKE position, cold engine. 3. Gasoline with more than 10% ethanol used. (E15, E20, E85, etc.) 4. Low quality or deteriorated, old gasoline. 5. Carburetor not primed. 6. Dirty fuel passageways. 7. Carburetor needle stuck. Fuel can be smelled in the air. 8. Too much fuel in chamber. This can be caused by the carburetor needle sticking. 9. Clogged Fuel Filter. 	<p>FUEL RELATED:</p> <ol style="list-style-type: none"> 1. Fill fuel tank and open fuel valve. 2. Move Choke to CHOKE position. 3. Clean out ethanol rich gasoline from fuel system. Replace components damaged by ethanol. Use fresh 87+ octane unleaded gasoline only. Do not use gasoline with more than 10% ethanol (E15, E20, E85, etc.). 4. Use fresh 87+ octane unleaded gasoline. Do not use gasoline with more than 10% ethanol (E15, E20, E85, etc.). 5. Pull on Starter Handle to prime. 6. Clean out passageways using fuel additive. Heavy deposits may require further cleaning. 7. Gently tap side of carburetor float chamber with screwdriver handle. 8. Turn Choke to RUN position. Remove spark plug and pull the start handle several times to air out the chamber. Reinstall spark plug and set Choke to CHOKE position. 9. Replace Fuel Filter.
	<p>IGNITION (SPARK) RELATED:</p> <ol style="list-style-type: none"> 1. Spark plug cap not connected securely. 2. Spark plug electrode wet or dirty. 3. Incorrect spark plug gap. 4. Spark plug cap broken. 5. Circuit breaker tripped (electric start models only). 6. Incorrect spark timing or faulty ignition system. 	<p>IGNITION (SPARK) RELATED:</p> <ol style="list-style-type: none"> 1. Connect spark plug cap properly. 2. Clean spark plug. 3. Correct spark plug gap. 4. Replace spark plug cap. 5. Reset circuit breaker. Check wiring and starter motor if breaker continues to trip. 6. Have qualified technician diagnose/repair ignition system.
	<p>COMPRESSION RELATED:</p> <ol style="list-style-type: none"> 1. Cylinder not lubricated. Problem after long storage periods. 2. Loose or broken spark plug. (Hissing noise will occur when trying to start.) 3. Loose cylinder head or damaged head gasket. (Hissing noise will occur when trying to start.) 4. Engine valves or tappets mis-adjusted or stuck. 	<p>COMPRESSION RELATED:</p> <ol style="list-style-type: none"> 1. Pour tablespoon of oil into spark plug hole. Crank engine a few times and try to start again. 2. Tighten spark plug. If that does not work, replace spark plug. If problem persists, may have head gasket problem, see #3. 3. Tighten head. If that does not remedy problem, replace head gasket. 4. Have qualified technician diagnose/repair ignition system.



Follow all safety precautions whenever diagnosing or servicing the equipment or engine.

Problem	Possible Causes	Probable Solutions
Engine misfires	<ol style="list-style-type: none"> 1. Spark plug cap loose. 2. Incorrect spark plug gap or damaged spark plug. 3. Defective spark plug cap. 4. Old or low quality gasoline. 5. Incorrect compression. 	<ol style="list-style-type: none"> 1. Check wire connections. 2. Re-gap or replace spark plug. 3. Replace spark plug cap. 4. Use only fresh 87+ octane unleaded gasoline. Do not use gasoline with more than 10% ethanol (E15, E20, E85, etc.). 5. Diagnose and repair compression. (Use Engine will not start: COMPRESSION RELATED section.)
Engine stops suddenly	<ol style="list-style-type: none"> 1. Low oil shutdown. 2. Fuel tank empty or full of impure or low quality gasoline. 3. Defective fuel tank cap creating vacuum, preventing proper fuel flow. 4. Faulty magneto. 5. Disconnected or improperly connected spark plug cap. 	<ol style="list-style-type: none"> 1. Fill engine oil to proper level. Check engine oil before EVERY use. 2. Fill fuel tank with fresh 87+ octane unleaded gasoline. Do not use gasoline with more than 10% ethanol (E15, E20, E85, etc.). 3. Test/replace fuel tank cap. 4. Have qualified technician service magneto. 5. Secure spark plug cap.
Engine stops when under heavy load	<ol style="list-style-type: none"> 1. Dirty air filter 2. Engine running cold. 	<ol style="list-style-type: none"> 1. Clean or replace element. 2. Allow engine to warm up prior to operating equipment.
Engine knocks	<ol style="list-style-type: none"> 1. Old or low quality gasoline. 2. Engine overloaded. 3. Incorrect spark timing, deposit buildup, worn engine, or other mechanical problems. 	<ol style="list-style-type: none"> 1. Fill fuel tank with fresh 87+ octane unleaded gasoline. Do not use gasoline with more than 10% ethanol (E15, E20, E85, etc.). 2. Do not exceed equipment's load rating. 3. Have qualified technician diagnose and service engine.
Engine backfires	<ol style="list-style-type: none"> 1. Impure or low quality gasoline. 2. Engine too cold. 3. Intake valve stuck or overheated engine. 4. Incorrect timing. 	<ol style="list-style-type: none"> 1. Fill fuel tank with fresh 87+ octane unleaded gasoline. Do not use gasoline with more than 10% ethanol (E15, E20, E85, etc.). 2. Use cold weather fuel and oil additives to prevent backfiring. 3. Have qualified technician diagnose and service engine. 4. Check engine timing.



Follow all safety precautions whenever diagnosing or servicing the equipment or engine.

Limited 90 Day Warranty

Harbor Freight Tools Co. makes every effort to assure that its products meet high quality and durability standards, and warrants to the original purchaser that this product is free from defects in materials and workmanship for the period of 90 days from the date of purchase. This warranty does not apply to damage due directly or indirectly, to misuse, abuse, negligence or accidents, repairs or alterations outside our facilities, criminal activity, improper installation, normal wear and tear, or to lack of maintenance. We shall in no event be liable for death, injuries to persons or property, or for incidental, contingent, special or consequential damages arising from the use of our product. Some states do not allow the exclusion or limitation of incidental or consequential damages, so the above limitation of exclusion may not apply to you. THIS WARRANTY IS EXPRESSLY IN LIEU OF ALL OTHER WARRANTIES, EXPRESS OR IMPLIED, INCLUDING THE WARRANTIES OF MERCHANTABILITY AND FITNESS.

To take advantage of this warranty, the product or part must be returned to us with transportation charges prepaid. Proof of purchase date and an explanation of the complaint must accompany the merchandise. If our inspection verifies the defect, we will either repair or replace the product at our election or we may elect to refund the purchase price if we cannot readily and quickly provide you with a replacement. We will return repaired products at our expense, but if we determine there is no defect, or that the defect resulted from causes not within the scope of our warranty, then you must bear the cost of returning the product.

This warranty gives you specific legal rights and you may also have other rights which vary from state to state.

**3491 Mission Oaks Blvd. • PO Box 6009
Camarillo, CA 93011 • (800) 520-0882**

Emission Control System Warranty

United States Emission Control Defects Warranty Statement (for Model 68120)

The United States Environmental Protection Agency (herein EPA) and Harbor Freight Tools (herein HFT) are pleased to explain the emission control system warranty on your 1997 and later Small Off-Road Engine (herein engine). Within the United States, new off-road, spark-ignition engines certified for model year 1997 and later, must be designed, built and equipped to meet the stringent anti-smog standards set forth by the EPA. HFT must warrant the emission control system on your engine for the periods of time described below, provided there has been no abuse, neglect or improper maintenance of your engine.

Your emission control system may include parts such as the carburetor or fuel-injection system, and the ignition system. Also included may be hoses, belts, connectors and other emission-related assemblies.

Where a warrantable condition exists, HFT will repair your engine at no cost to you including diagnosis, parts and labor.

California and United States Emission Control Defects Warranty Statement (for Models 68306, 68121, and 68136)

The California Air Resources Board (herein CARB), the United States Environmental Protection Agency (herein EPA), and Harbor Freight Tools (herein HFT) are pleased to explain the emission control system warranty on your 1995 and later Small Off-Road Engine (herein engine). In California, the engine must be designed, built and equipped to meet the State's stringent anti-smog standards. Elsewhere within the United States, new off-road, spark-ignition engines certified for model year 1997 and later, must meet similar standards set forth by the EPA. HFT must warrant the emission control system on your engine for the periods of time described below, provided there has been no abuse, neglect or improper maintenance of your engine.

Your emission control system may include parts such as the carburetor or fuel-injection system, and the ignition system. Also included may be hoses, belts, connectors and other emission-related assemblies.

Where a warrantable condition exists, HFT will repair your engine at no cost to you including diagnosis, parts and labor.

Manufacturer's Warranty Coverage

The 1995 and later engines are warranted for two (2) years. If any emission-related part on your engine is defective, the part will be repaired or replaced by HFT.

Harbor Freight Tools Emission Control Defects Warranty Coverage

Engines are warranted for a period of two (2) years relative to emission control parts defects, subject to the provisions set forth below. If any emission related part on your engine is defective, the part will be repaired or replaced by HFT.

Owner's Warranty Responsibilities

- As the engine owner, you are responsible for the performance of the required maintenance listed in your Owner's Manual. HFT recommends that you retain all receipts covering maintenance on your engine, but HFT cannot deny warranty solely for the lack of receipts or for your failure to ensure the performance of all scheduled maintenance.
- As the engine owner, you should, however, be aware that HFT may deny you warranty coverage if your engine or a part has failed due to abuse, neglect, improper maintenance, or unapproved modifications.
- You are responsible for shipping your engine to a HFT warranty station as soon as a problem exists. Contact the HFT Customer Service department at the number below to make shipping arrangements. The warranty repairs should be completed in a reasonable amount of time, not to exceed 30 days.

If you have any questions regarding your warranty rights and responsibilities, you should contact the Harbor Freight Tools Customer Service Department at 1-800-520-0882.

Harbor Freight Tools Emission Control Defects Warranty Provisions

1. Length of Coverage

HFT warrants to a first retail purchaser and each subsequent purchaser that the engine is free from defects in materials and workmanship that cause the failure of warranted parts for a period of two (2) years after the date of delivery to the first retail purchaser.

2. No Charge Repair or Replacement

Repair or replacement of any warranted part will be performed at no charge to the owner if the work is performed through a warranty station authorized by HFT. For emissions warranty service, contact the HFT Customer Service Department at 1-800-520-0882.

3. Consequential Damages Coverage

Coverage under this warranty shall also extend to the failure of any engine components caused by the failure of any warranted part while it is still covered under this warranty.

4. Coverage Exclusions

Warranty claims shall be filed in accordance with the provisions of the HFT warranty policy explained in the box at the top of the previous page. HFT shall not be liable for any loss of use of the engine, for any alternative usage, for any damage to goods, loss of time, or inconvenience. Warranty coverage shall also be excluded for any part which fails, malfunctions, or is damaged due to failure to follow the maintenance and operating instructions set forth in the Owner's Manual including, but not limited to:

- a) Use of parts which are not authorized by HFT
- b) Improper installation, adjustment or repair of the engine or of any warranted part unless performed by an authorized warranty center
- c) Failure to follow recommendations on fuel use contained in the Owner's Manual
- d) Improper or inadequate maintenance of any warranted parts
- e) Repairs performed outside of the authorized warranty service dealers
- f) Alterations by changing, adding to or removing parts from the engine.

5. Service and Maintenance

Component parts which are not scheduled for replacement as required maintenance or are scheduled only for regular inspection to the effect of "repair or replace as necessary" are warranted for the warranty period. Any warranted part which is scheduled for replacement as required maintenance is warranted for the period of time up to the first scheduled replacement point for that part. Any replacement part, provided it is equivalent in durability and performance, may be used in performance of maintenance or repairs. The owner is responsible for commissioning a qualified technician/mechanic to perform all required maintenance, as outlined in the Inspection, Cleaning, and Maintenance section in this manual.

6. Warranted Parts

1) Fuel Metering System

- i) Carburetor and its internal parts.
- ii) Fuel pump (if so equipped).
- iii) Cold start enrichment system.

2) Air Induction System

- i) Intake pipe/manifold.
- ii) Air cleaner.

3) Ignition System

- i) Spark plug.
- ii) Magneto ignition system.

4) Catalyst System (if so equipped)

- i) Exhaust pipe stud.
- ii) Muffler.
- iii) Catalytic converter (if so equipped).

5) Miscellaneous Items Used in Above Systems

- i) Vacuum, temperature and time sensitive valves and switches.
- ii) Hoses, belts, connectors, and assemblies.

68120 212cc Parts List and Diagram

Part	Description	Qty.
1	Gasket, Cylinder Head	1
2	Cover Asm., Cylinder Head	1
3	Gasket, Cylinder Head Cover	1
4	Tube, Breather	1
5	Bolt	4
6	Stud	1
7	Stud	1
8	Stud	2
9	Pin	2
10	Bolt, Cylinder Head	4
11	Plug, Spark	1
12	Head Asm., Cylinder	1
13	Crankcase Asm.	1
14	Sensor, Engine Oil	1
15	Gear Asm., Governor	1
16	Arm, Governor	1
17	Bolt, Drain Plug	2
18	Washer	2
19	Bearing	1
20	Seal, Oil	1
21	Washer	1
22	Pin	1
23	Bolt	2
24	Cover, Crankcase	1
25	Bearing	1
26	Seal, Oil	1
27	Gasket, Crankcase	1
28	Pin	2
29	Dipstick Asm., Oil	1
30	Plug Asm., Engine Oil	1
31	Bolt	6
32	Crankshaft Asm.	1
33	Clip, Piston Pin	2
34	Piston	1
35	Pin, Piston	1
36	Rod, Connecting	1
37	Ring, The First	1
38	Ring, The Second	1
39	Ring Set, Oil	1
40	Camshaft Asm.	1
41	Valve, Exhaust	1
42	Valve, Intake	1
43	Seat, Valve Spring	1
44	Retainer Exhaust Valve	1
45	Rotator, Valve	1
46	Guide, Seal	1
47	Tappet, Valve	2
48	Lifter, Valve	2
49	Plate Asm., Lifter Stopper	1
50	Bolt, Valve Adjusting	2

Part	Description	Qty.
51	Rocker, Valve	2
52	Nut Valve Adjusting	2
53	Nut, Valve Lock	2
54	Spring, Valve	2
55	Starter Asm., Recoil	1
56	Bolt	3
57	Shroud	1
58	Shroud, Cylinder Body	1
59	Shield, Lower	1
60	Protector, Oil	1
61	Switch Asm., Stop Engine	1
62	Bolt	2
63	Bolt	1
64	Collar	1
65	Bolt	1
66	Bolt	4
67	Carburetor Asm.	1
68	Gasket, Air Cleaner	1
69	Gasket, Carburetor	1
70	Plate, Carburetor Insulator	1
71	Gasket, Carburetor Insulator	1
72	Nut	2
73	Cleaner, Air	1
74	Bolt	1
75	Gasket, Exhaust Outlet	1
76	Nut	2
77	Muffler Asm.	1
78	Tank, Fuel	1
79	Strainer, Fuel	1
80	Cover, Fuel Tank	1
81	Outlet Asm., Fuel Tank Oil	1
82	Collar	2
83	Tube, Fuel	1
84	Bolt	1
85	Nut	2
86	Nut, Flywheel	1
87	Pulley, Starter	1
88	Impeller	1
89	Flywheel Asm.	1
90	Bolt	2
91	Coil, Ignition	1
92	Control Asm., Throttle	1
93	Bolt	2
94	Spring, Governor	1
95	Rod, Governor	1
96	Spring, Throttle Valve Returning	1
97	Bolt, Governor Support	1
98	Nut	1
99	Support Asm., Governor	1

68120 212cc Parts List and Diagram

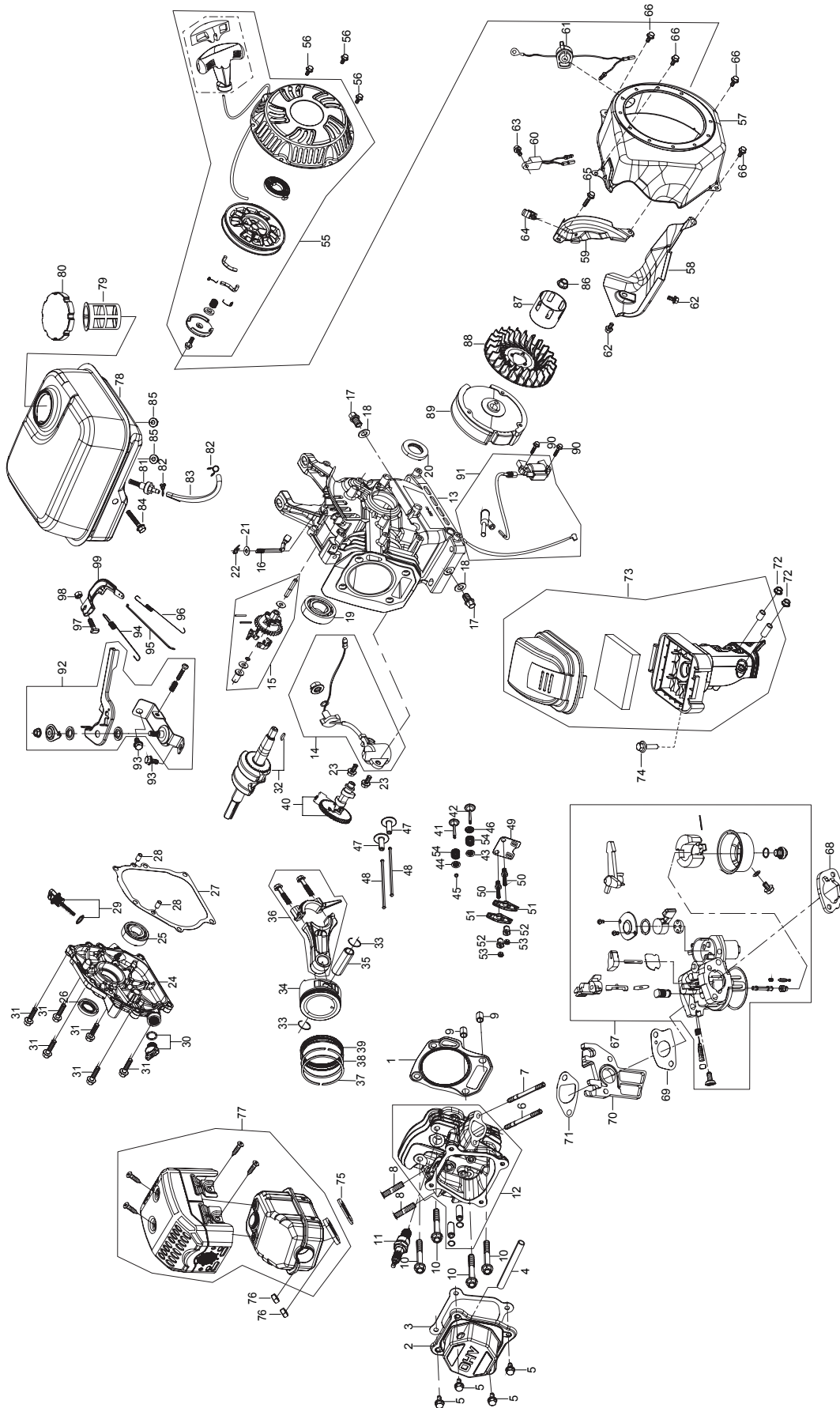

68121 212cc Parts List and Diagram

Part	Description	Qty.
1	Gasket, Cylinder Head	1
2	Cover Asm., Cylinder Head	1
3	Gasket, Cylinder Head Cover	1
4	Tube, Breather	1
5	Bolt	4
6	Stud	1
7	Stud	1
8	Stud	2
9	Pin	2
10	Bolt, Cylinder Head	4
11	Plug, Spark	1
12	Head Asm., Cylinder	1
13	Crankcase Asm.	1
14	Sensor, Engine Oil	1
15	Gear Asm., Governor	1
16	Arm, Governor	1
17	Bolt, Drain Plug	2
18	Washer	2
19	Bearing	1
20	Seal, Oil	1
21	Washer	1
22	Pin	1
23	Bolt	2
24	Cover, Crankcase	1
25	Bearing	1
26	Seal, Oil	1
27	Gasket, Crankcase	1
28	Pin	2
29	Dipstick Asm., Oil	1
30	Plug Asm., Engine Oil	1
31	Bolt	6
32	Crankshaft Asm.	1
33	Clip, Piston Pin	2
34	Piston	1
35	Pin, Piston	1
36	Rod, Connecting	1
37	Ring, The First	1
38	Ring, The Second	1
39	Ring Set, Oil	1
40	Camshaft Asm.	1
41	Valve, Exhaust	1
42	Valve, Intake	1
43	Seat, Valve Spring	1
44	Retainer Exhaust Valve	1
45	Rotator, Valve	1
46	Guide, Seal	1
47	Tappet, Valve	2
48	Lifter, Valve	2
49	Plate Asm., Lifter Stopper	1
50	Bolt, Valve Adjusting	2
51	Rocker, Valve	2
52	Nut Valve Adjusting	2
53	Nut, Valve Lock	2
54	Spring, Valve	2

Part	Description	Qty.
55	Starter Asm., Recoil	1
56	Bolt	3
57	Shroud	1
58	Shroud, Cylinder Body	1
59	Shield, Lower	1
60	Protector, Oil	1
61	Switch Asm., Stop Engine	1
62	Bolt	2
63	Bolt	1
64	Collar	1
65	Bolt	1
66	Bolt	4
67	Carburetor Asm.	1
68	Gasket, Air Cleaner	1
69	Gasket, Carburetor	1
70	Plate, Carburetor Insulator	1
71	Gasket, Carburetor Insulator	1
72	Nut	2
73	Cleaner, Air	1
74	Bolt	1
75	Gasket, Exhaust Outlet	1
76	Nut	2
77	Muffler Asm.	1
78	Bolt	2
79	Gasket, Auxiliary Air Valve Flange	1
80	Valve, Muffler Auxiliary	1
81	Tank, Fuel	1
82	Strainer, Fuel	1
83	Cap, Fuel	1
84	Outlet Asm., Fuel Tank Oil	1
85	Clamp	4
86	Tube, Fuel	1
87	Bolt	1
88	Nut	2
89	Vent, Vapor	1
90	Hose, Vapor Rubber	1
91	Band	2
92	Collector, Vapor	1
93	Clamp	2
94	Hose, Air Cleaner Rubber	1
95	Nut, Flywheel	1
96	Pulley, Starter	1
97	Impeller	1
98	Flywheel Asm.	1
99	Bolt	2
100	Coil, Ignition	1
101	Control Asm., Throttle	1
102	Bolt	2
103	Spring, Governor	1
104	Rod, Governor	1
105	Spring, Throttle Valve Returning	1
106	Bolt, Governor Support	1
107	Nut	1
108	Support Asm., Governor	1

68121 212cc Parts List and Diagram

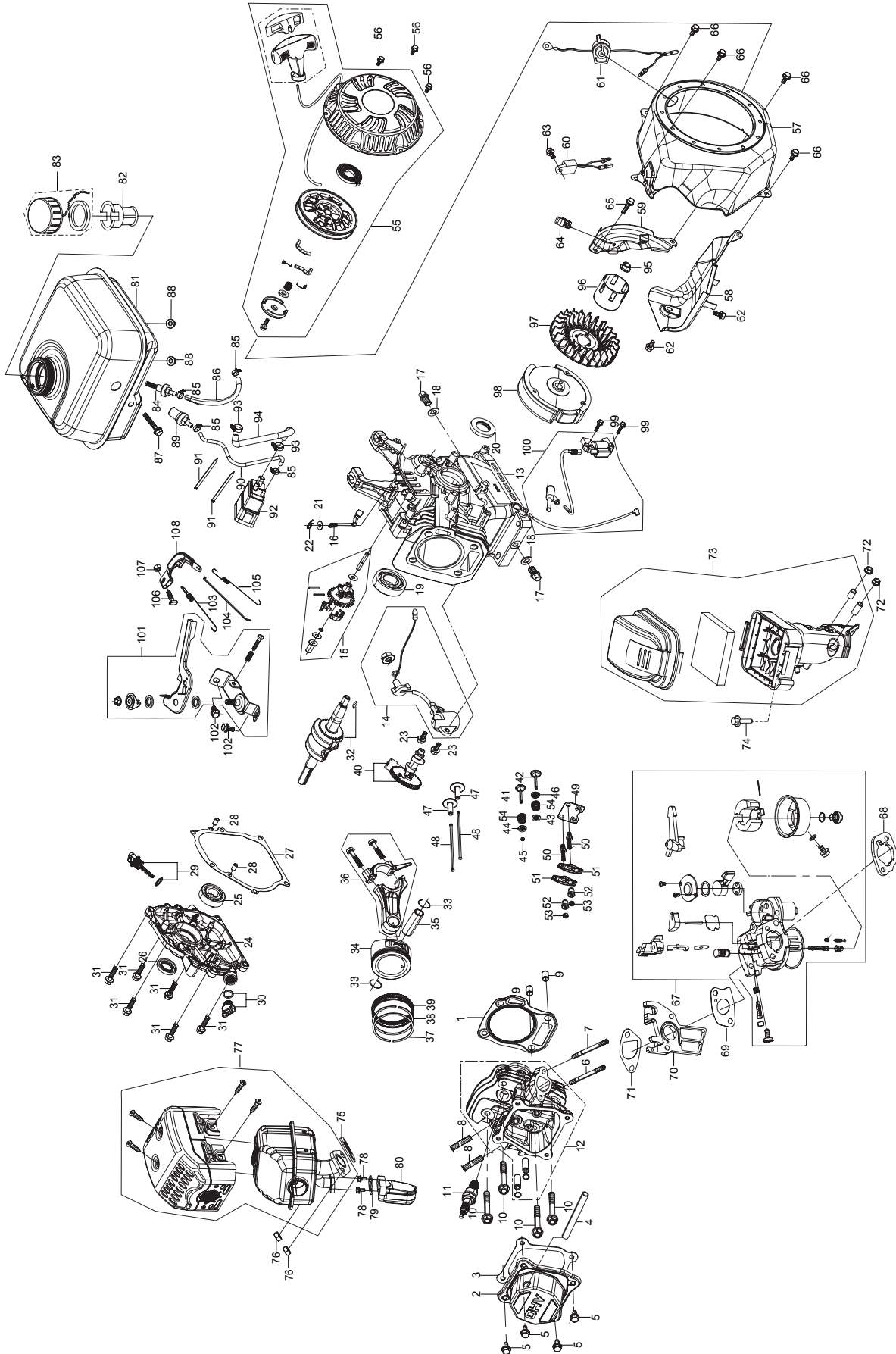

68136 346cc Parts List and Diagram

Part	Description	Qty.
1	Gasket, Cylinder Head	1
2	Cover Asm., Cylinder Head	1
3	Gasket, Cylinder Head Cover	1
4	Tube, Breather	1
5	Bolt Asm., Cylinder Head Cover	1
6	Stud	2
7	Stud	2
8	Pin	2
9	Bolt, Cylinder Head	4
10	Plug, Spark	1
11	Head Asm., Cylinder	1
12	Crankcase Asm.	1
13	Seal, Oil	1
14	Sensor, Engine Oil	1
15	Frame, Fuel Tank Installation	1
16	Plug, Rubber	1
17	Protector, Oil	1
18	Bolt	1
19	Washer Flat	2
20	Bolt, Drain Plug	2
21	Clip	1
22	Arm, Governor	1
23	Seal, Oil	1
24	Pin	1
25	Bolt	4
26	Bolt	2
27	Washer Flat	1
28	Bearing	1
29	Cover, Crankcase	1
30	Gasket, Crankcase	1
31	Plug Asm., Engine Oil	1
32	Dipstick Asm., Oil	1
33	Pin	2
34	Bolt	7
35	Bearing	1
36	Gear Asm., Governor	1
37	Seal, Oil	1
38	Bearing	1
39	Crankshaft Asm.	1
40	Shaft Asm., Balancing	1
41	Ring Set, Oil	1
42	Clip, Piston Pin	2
43	Piston	1
44	Pin, Piston	1
45	Rod, Connecting	1
46	Ring, The First	1
47	Ring, The Second	1
48	Camshaft Asm.	1
49	Valve, Exhaust	1
50	Valve, Intake	1
51	Seat, Valve Spring	1
52	Retainer, Exhaust Valve	1
53	Rotator, Valve	1
54	Guide, Seal	1
55	Tappet, Valve	2
56	Lifter Asm., Valve	2

Part	Description	Qty.
57	Plate Asm., Lifter Stopper	1
58	Bolt, Valve Adjusting	2
59	Rocker, Valve	2
60	Nut, Valve Adjusting	2
61	Nut, Valve Lock	2
62	Spring, Valve	2
63	Retainer, Valve Spring	1
64	Starter Asm., Recoil	1
65	Bolt	3
66	Shroud	1
67	Shroud, Cylinder Body	1
68	Bolt	1
69	Bolt	5
70	Carburetor Asm.	1
71	Gasket, Air Cleaner	1
72	Gasket, Carburetor	1
73	Plate, Carburetor Insulator	1
74	Gasket, Inlet	1
75	Nut	2
76	Cleaner, Air	1
77	Bolt	1
78	Nut	3
79	Gasket, Exhaust Outlet	1
80	Nut	2
81	Muffler Asm.	1
82	Gasket, Aux. Air Valve Flange	1
83	Valve, Muffler Aux. Air	1
84	Bolt	2
85	Tank, Fuel	1
86	Strainer, Fuel	1
87	Cover, Fuel Tank	1
88	Outlet Asm., Fuel Tank Oil	1
89	Collar	5
90	Tube, Fuel	1
91	Clamp	1
92	Nut	2
93	Valve, One Way	1
94	Hose, Fuel Steam Rubber	1
95	Hose, Air Cleaner Rubber	1
96	Collector, Fuel Steam	1
97	Bolt	2
98	Cover, Fuel Steam Collector	1
99	Nut, Flywheel	1
100	Pulley, Starter	1
101	Impeller	1
102	Flywheel Asm.	1
103	Bolt	2
104	Coil, Ignition	1
105	Control Asm., Throttle	1
106	Bolt	2
107	Spring, Throttle Valve Returning	1
108	Rod, Governor	1
109	Support Asm., Governor	1
110	Nut	1
111	Bolt, Governor Support	1
112	Spring, Governor	1

68136 346cc Parts List and Diagram

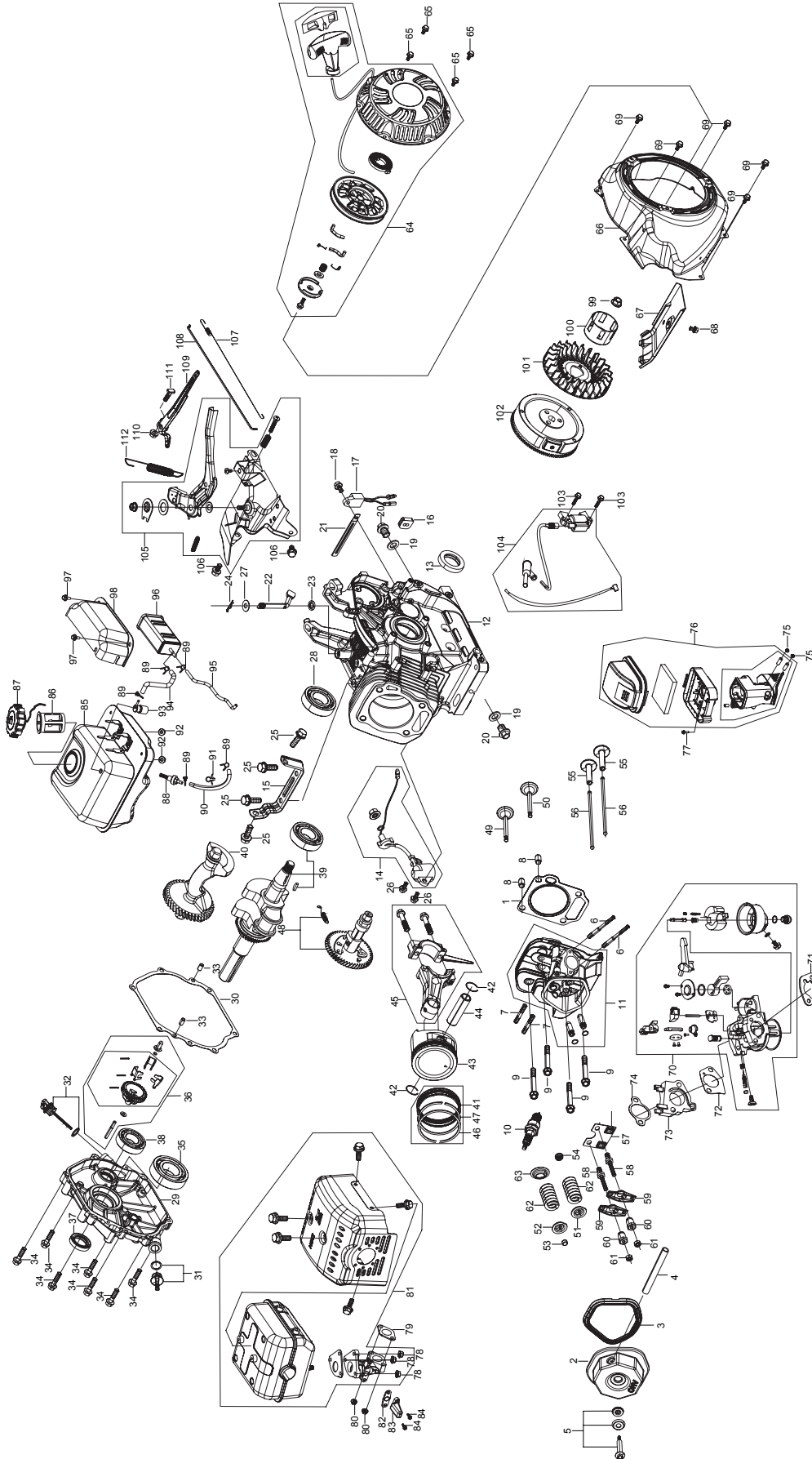

68306 420cc Parts List and Diagram

Part	Description	Qty.
1	Gasket, Cylinder Head	1
2	Cover Asm., Cylinder Head	1
3	Gasket, Cylinder Head Cover	1
4	Tube, Breather	1
5	Bolt Asm., Cylinder Head Cover	1
6	Stud	2
7	Stud	2
8	Pin	2
9	Bolt, Cylinder Head	4
10	Plug, Spark	1
11	Head Asm., Cylinder	1
12	Crankcase Asm.	1
13	Seal, Oil	1
14	Sensor, Engine Oil	1
15	Frame, Fuel Tank	1
16	Plug, Rubber	1
17	Protector, Oil	1
18	Bolt	1
19	Washer Flat	2
20	Bolt, Drain Plug	2
21	Clip	1
22	Arm, Governor	1
23	Seal, Oil	1
24	Pin	1
25	Bolt	4
26	Bolt	2
27	Washer Flat	1
28	Bearing	1
29	Cover, Crankcase	1
30	Gasket, Crankcase	1
31	Plug Asm., Engine Oil	1
32	Dipstick Asm., Oil	1
33	Pin	2
34	Bolt	7
35	Bearing	1
36	Gear Asm., Governor	1
37	Seal, Oil	1
38	Bearing	1
39	Crankshaft Asm.	1
40	Shaft Asm., Balancing	1
41	Ring Set, Oil	1
42	Clip, Piston Pin	2
43	Piston	1
44	Pin, Piston	1
45	Rod, Connecting	1
46	Ring, The First	1
47	Ring, The Second	1
48	Camshaft Asm.	1
49	Valve, Exhaust	1
50	Valve, Intake	1
51	Seat, Valve Spring	1
52	Retainer, Exhaust Valve	1
53	Rotator, Valve	1
54	Guide, Seal	1
55	Tappet, Valve	2
56	Lifter Asm., Valve	2
57	Plate Asm., Lifter Stopper	1
58	Bolt, Valve Adjusting	2
59	Rocker, Valve	2
60	Nut, Valve Adjusting	2
61	Nut, Valve Lock	2

Part	Description	Qty.
62	Spring, Valve	2
63	Retainer, Valve Spring	1
64	Starter Asm., Recoil	1
65	Bolt	4
66	Shroud	1
67	Shroud, Cylinder Body	1
68	Bolt	1
69	Bolt	5
70	Carburetor Asm.	1
71	Gasket, Air Cleaner	2
72	Gasket, Carburetor	1
73	Plate, Carburetor Insulator	1
74	Gasket, Inlet	1
75	Nut	2
76	Cleaner, Air	1
77	Bolt	1
78	Nut	3
79	Gasket, Exhaust Outlet	1
80	Nut	2
81	Muffler Asm.	1
82	Gasket, Aux. Air Intake Valve	1
83	Valve, Aux. Air Intake	1
84	Bolt	2
85	Tank, Fuel	1
86	Strainer, fuel	1
87	Cover, Fuel Tank	1
88	Outlet Asm., Fuel Tank Oil	1
89	Collar	5
90	Tube, Fuel	1
91	Clip	1
92	Nut	2
93	Valve, One Way	1
94	Hose, Fuel Steam Rubber	1
95	Hose, Air Cleaner Rubber	1
96	Collector, Fuel Steam	1
97	Bolt	2
98	Cover, Fuel Steam Collector	1
99	Nut, Flywheel	1
100	Pulley, Starter	1
101	Impeller	1
102	Flywheel Asm.	1
103	Bolt	1
104	Cap, Spark Plug	1
105	Coil Asm., Charge	1
106	Bolt	2
107	Coil, Ignition	1
108	Bolt	2
109	Control Asm., Throttle	1
110	Bolt	2
111	Spring, Throttle Returning	1
112	Rod, Governor	1
113	Support Asm., Governor	1
114	Nut	1
115	Bolt, Governor Support	1
116	Spring, Governor	1
117	Motor Asm., Starting	1
118	Bolt	2
119	Relay, Starting	1
120	Bolt	2
121	Switch, Control	1
122	Bolt	2

68306 420cc Parts List and Diagram

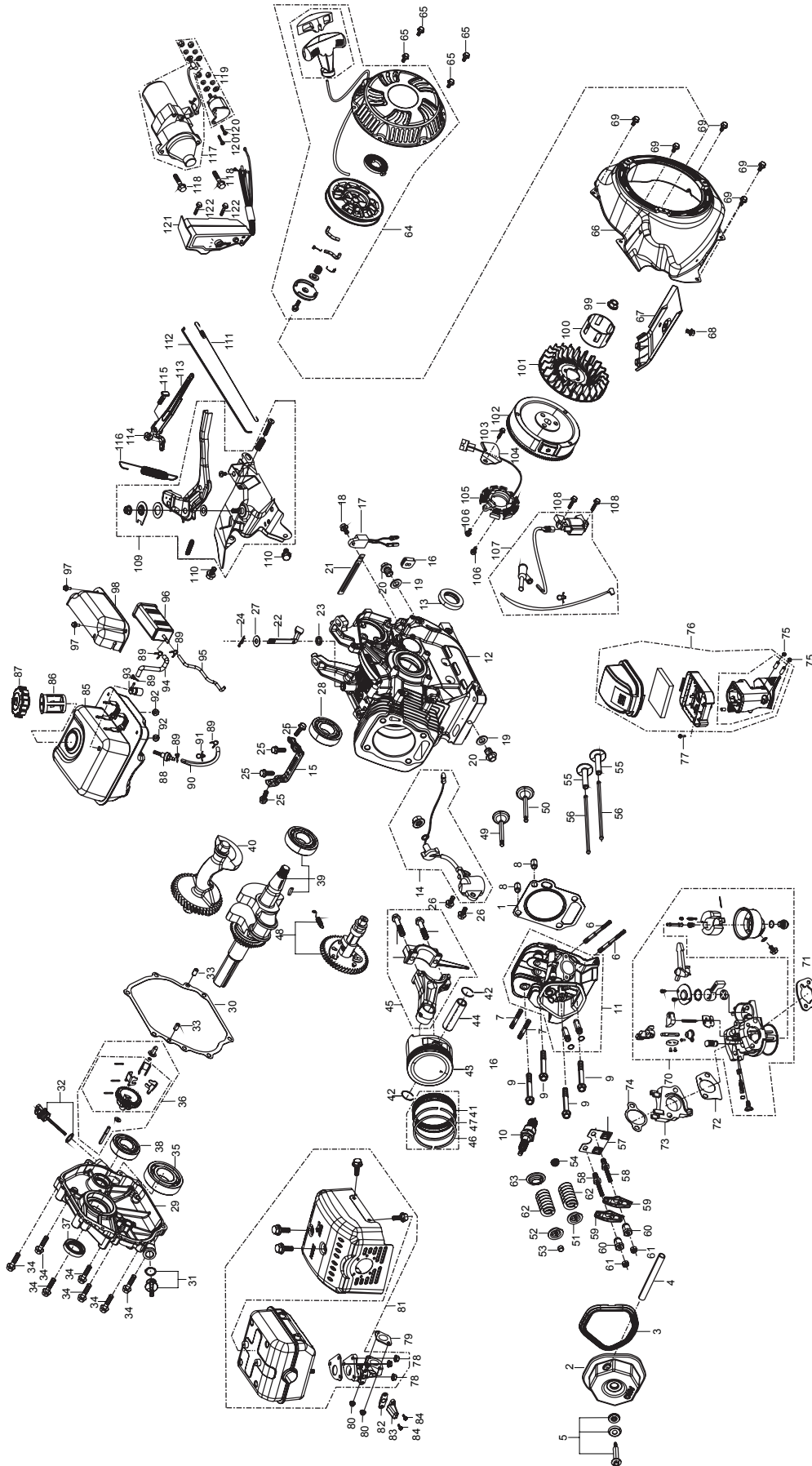

Mounting Hole Diagrams

Note: Not to scale.

ITEM 68120 / 68121 212cc

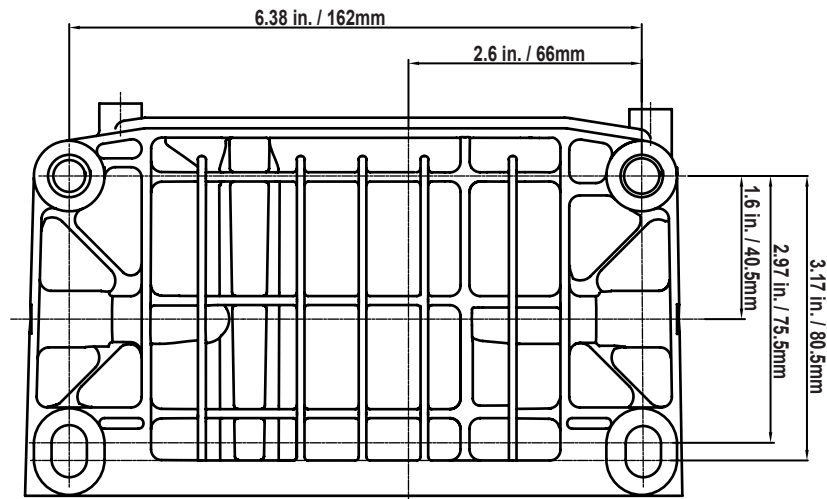

ITEM 68136 346cc and ITEM 68306 420cc

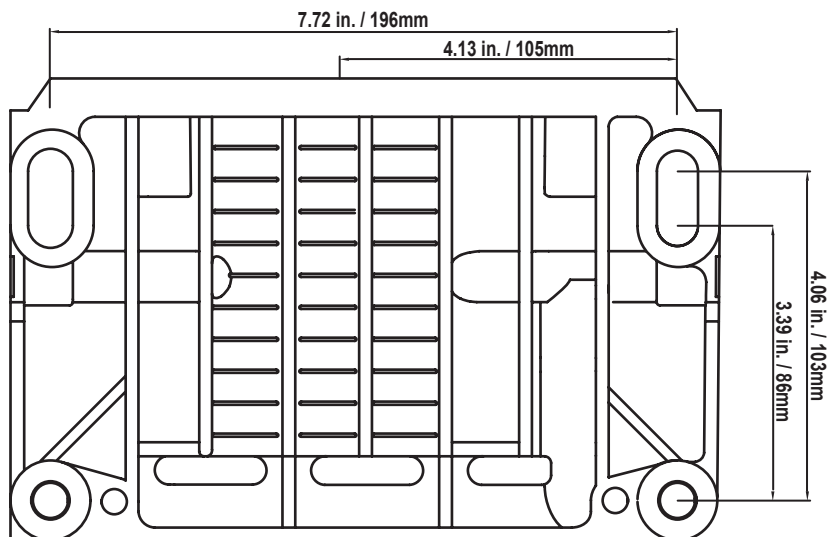

Power Take-Off Diagrams

Note: Not to scale.

ITEM 68120 / 68121 212cc

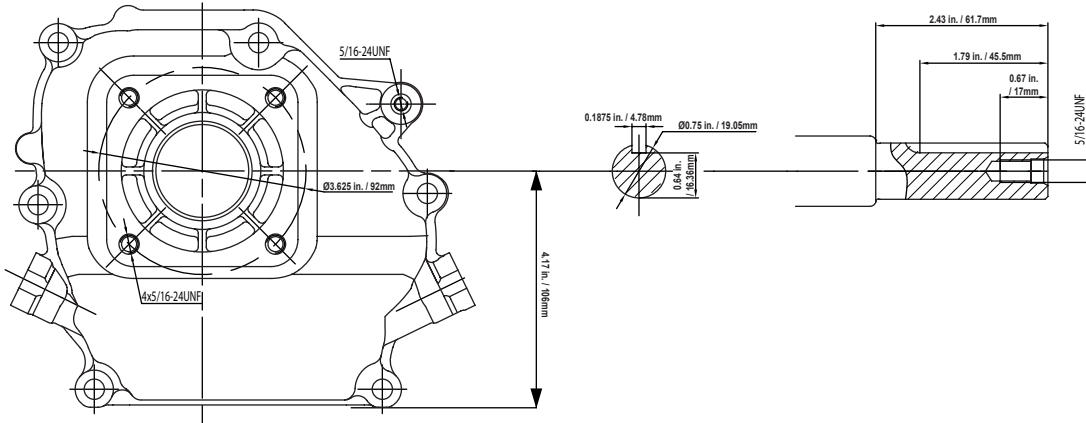

ITEM 68136 346cc and ITEM 68306 420cc

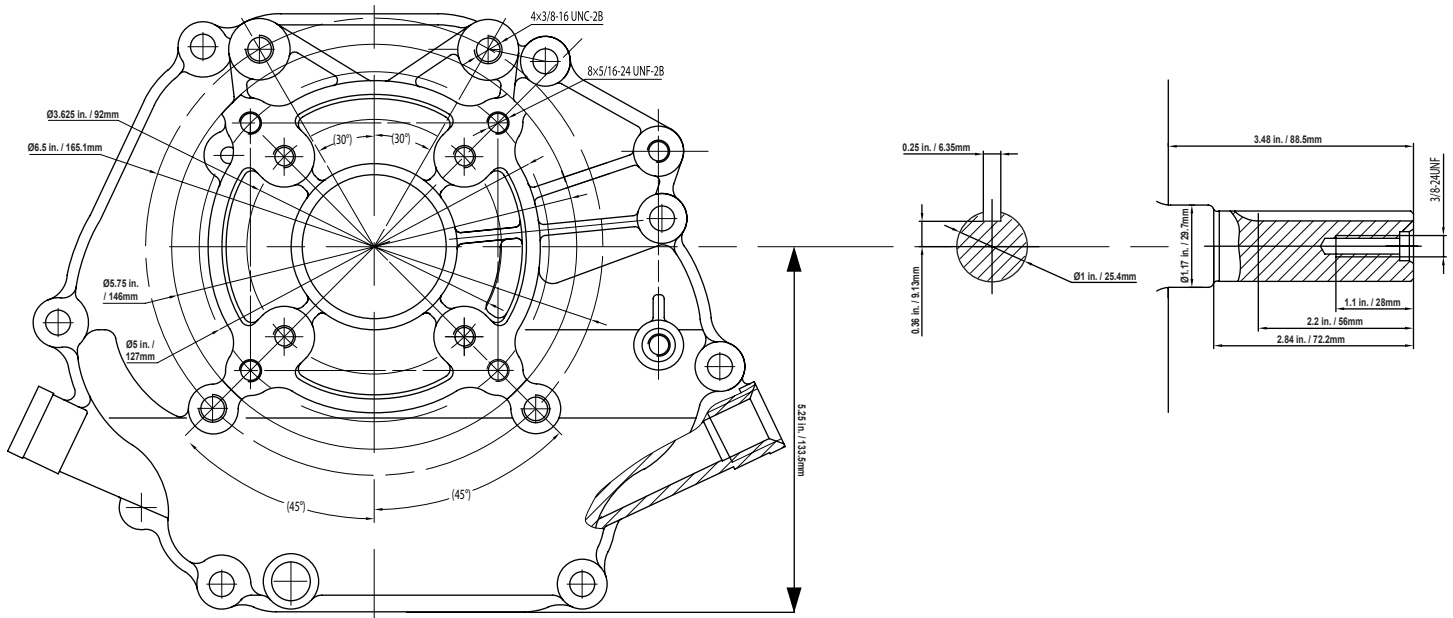

PREDATOR™ E N G I N E S

3491 Mission Oaks Blvd. • PO Box 6009 • Camarillo, CA 93011 • (800) 520-0882

www.harborfreight.com

Free Manuals Download Website

<http://myh66.com>

<http://usermanuals.us>

<http://www.somanuals.com>

<http://www.4manuals.cc>

<http://www.manual-lib.com>

<http://www.404manual.com>

<http://www.luxmanual.com>

<http://aubethermostatmanual.com>

Golf course search by state

<http://golfingnear.com>

Email search by domain

<http://emailbydomain.com>

Auto manuals search

<http://auto.somanuals.com>

TV manuals search

<http://tv.somanuals.com>