

CENTRAL PNEUMATIC[®]

AIR COMPRESSOR PUMP 3 HORSEPOWER

Model 09592

ASSEMBLY AND OPERATING INSTRUCTIONS

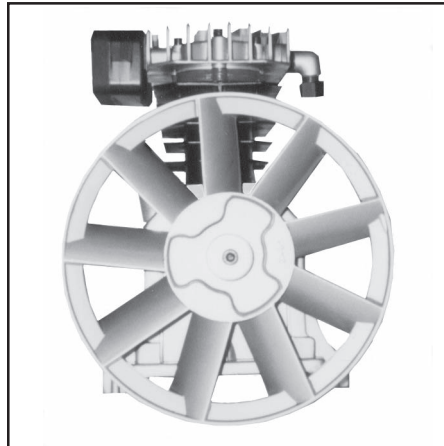

3491 Mission Oaks Blvd., Camarillo, CA 93011
Visit our Web site at <http://www.harborfreight.com>

Copyright© 2003 by Harbor Freight Tools[®]. All rights reserved. No portion of this manual or any artwork contained herein may be reproduced in any shape or form without the express written consent of Harbor Freight Tools.

For technical questions, please call 1-800-444-3353.

PRODUCT SPECIFICATIONS

Item	Description
Product Capability	For use with 3 HP, 3400 RPM (not included)
Pump Stage	Single
Maximum Pressure	140 PSI
Maximum Intake Capacity	8.05 CFM
Pump RPM	1,200 RPM
Cylinder Design	Twin
Stroke	1.57"
Oil Capacity	28.73 ounces
Shaft Diameter	15/16"
Mounting Holes	Qty. 4 / 3/8" Diameter / Bolt Pattern: 5-1/2" L x 7-1/2" W
Lubrication System Design	Splash
Construction	Aluminum Head, Pump, Flywheel / Cast Iron Sleeve
Pulley Design / Size	Belt Driven 10-5/8" Dia. X 1/2" Belt, CCW Rotation
Weight	23.25 Pounds

SAVE THIS MANUAL

You will need this manual for the safety warnings and precautions, assembly, operating, inspection, maintenance and cleaning procedures, parts list and assembly diagram. Keep your invoice with this manual. Write the invoice number on the inside of the front cover. Keep this manual and invoice in a safe and dry place for future reference.

GENERAL SAFETY WARNINGS AND PRECAUTIONS

1. **KEEP WORK AREA CLEAN AND DRY.** Cluttered, damp, or wet work areas invite injuries.
2. **KEEP CHILDREN AWAY FROM WORK AREA.** Do not allow children to handle this product.
3. **STORE IDLE EQUIPMENT.** When not in use, tools and equipment should be stored in a dry location to inhibit rust. Always lock up tools and equipment, and keep out of reach of children.
4. **DO NOT USE THIS PRODUCT IF UNDER THE INFLUENCE OF ALCOHOL OR DRUGS.** Read warning labels on prescriptions to determine if your judgement or reflexes are impaired while taking drugs. If there is any doubt, do not attempt to use this product.

5. **USE EYE AND HAND PROTECTION.** Wear ANSI approved safety impact eye goggles and heavy-duty work gloves when using this product. ANSI approved safety impact eye goggles and heavy-duty work gloves are available from Harbor Freight Tools.
6. **DRESS SAFELY.** Do not wear loose clothing or jewelry, as they can become caught in moving parts. Wear a protective hair covering to prevent long hair from becoming caught in moving parts. If wearing a long-sleeve shirt, roll sleeves up above elbows.
7. **DO NOT OVERREACH.** Keep proper footing and balance at all times to prevent tripping, falling, back injury, etcetera.
8. **INDUSTRIAL APPLICATIONS MUST FOLLOW OSHA REQUIREMENTS.**
9. **STAY ALERT.** Watch what you are doing at all times. Use common sense. Do not use this product when you are tired or distracted from the job at hand.
10. **CHECK FOR DAMAGED PARTS.** Before using this product, carefully check that it will operate properly and perform its intended function. Check for damaged parts and any other conditions that may affect the operation of this product. Replace or repair damaged or worn parts immediately.
11. **REPLACEMENT PARTS AND ACCESSORIES:** When servicing, use only identical replacement parts. Only use accessories intended for use with this product. Approved accessories are available from Harbor Freight Tools.
12. **MAINTAIN THIS PRODUCT WITH CARE.** Keep this product clean and dry for better and safer performance.
13. **MAINTENANCE:** For your safety, service and maintenance should be performed regularly by a qualified technician.
14. **USE THE RIGHT TOOL FOR THE JOB.** Do not attempt to force a small tool or attachment to do the work of a larger industrial tool. There are certain applications for which this tool was designed. It will do the job better and more safely at the rate for which it was intended. Do not modify this tool, and do not use this tool for a purpose for which it was not intended.
15. **WARNING:** The warnings, precautions, and instructions discussed in this manual cannot cover all possible conditions and situations that may occur. The operator must understand that common sense and caution are factors, which cannot be built into this product, but must be supplied by the operator.

SPECIFIC PRODUCT WARNINGS AND PRECAUTIONS

1. **THIS AIR COMPRESSOR PUMP IS DESIGNED FOR USE ONLY WITH A 3 HORSEPOWER MOTOR 3,400 RPM (not included).**
2. **WARNING!** Make sure to fill the Air Compressor Pump with a premium quality, 30-weight, non-detergent oil before each use. Running the Air Compressor Pump with no oil or low oil will cause damage to the equipment.
3. **WHEN FILLING WITH OIL:** Make sure to **unscrew** (do not pull) the Oil Fill Plug (part #20) out. **(See Figure D.)**
4. **MAKE SURE ALL TOOLS AND EQUIPMENT USED WITH THE AIR COMPRESSOR PUMP ARE RATED TO THE APPROPRIATE CAPACITY.** Do not use any tool or equipment that does not operate from 0 to 140 PSI.
5. **MAINTAIN A SAFE WORKING ENVIRONMENT.** Keep the work area well lit. Make sure there is adequate surrounding workspace. Always keep the work area free of obstructions, grease, oil, trash, and other debris. Do not use the Air Compressor Pump in areas near flammable chemicals, dusts, and vapors.
6. **AVOID INJURY:** Never direct the Exhaust Elbow (part #3) at people or animals. **(See Figure D.)**
7. **AVOID BURNS:** The Air Compressor Pump becomes very hot during use and for a while after its use. Do not touch the Air Compressor Pump until it has completely cooled.
8. **WARNING! DO NOT USE THE AIR COMPRESSOR PUMP UNTIL A PROPERLY FUNCTIONING PULLEY/BELT GUARD (not included) HAS BEEN INSTALLED.** **(See Figure C.)**
9. **BEFORE PERFORMING ANY INSPECTION, MAINTENANCE, OR CLEANING PROCEDURES, MAKE SURE ALL AIR PRESSURE HAS BEEN RELEASED FROM THE AIR COMPRESSOR'S TANK (not included) AND THAT THE EQUIPMENT IS UNPLUGGED FROM ITS ELECTRICAL OUTLET, and ALL COMPONENTS HAVE COOLED.**
10. **WARNING!** This product contains or produces a chemical known to the State of California to cause cancer and birth defects (or other reproductive harm). *(California Health & Safety Code 25249.5 et seq.)*

UNPACKING

When unpacking, check to make sure all the parts shown on the **Parts List on page 9** are included. If any parts are missing or broken, please call Harbor Freight Tools at the number shown on the cover of this manual as soon as possible.

ASSEMBLY INSTRUCTIONS

NOTE: For additional references to the parts mentioned in the following pages, refer to the **Assembly Diagram on page 10**.

To Attach The Air Compressor Pump To A Mounting Surface:

1. **NOTE:** Depending on your level of assembly expertise, you may wish to have a qualified technician perform the assembly procedures.
2. **CAUTION:** Make sure the mounting surface (air compressor stand, work-bench, etc.) to which the Air Compressor Pump will be attached is flat, level, and sturdy enough to withstand the weight of the Air Compressor Pump and all other necessary equipment and accessories.
3. At the base of the Air Compressor Pump are *four* 3/8" mounting holes with a hole pattern of 5-1/2" long by 7-1/2" wide. If *four* 3/8" mounting holes with a hole pattern of 5-1/2" long by 7-1/2" wide do not already exist in the mounting surface, it will be necessary to drill the *four* 3/8" mounting holes through the mounting surface. **IMPORTANT:** Prior to drilling, make sure there are no electrical cables, wires or other obstructions in the drilling path. **(See Figure A.)**
4. To do so, temporarily position the Air Compressor Pump in the desired location on the mounting surface. Use the base of the Air Compressor Pump, with its four 3/8" mounting holes, as a template by which to mark the four 3/8" mounting holes that are to be drilled through the mounting surface. Then, remove the Air Compressor Pump from the mounting surface. **NOTE:** You may also follow the illustration below by which to measure where each of the four 3/8" mounting holes should be drilled. **(See Figure A.)**

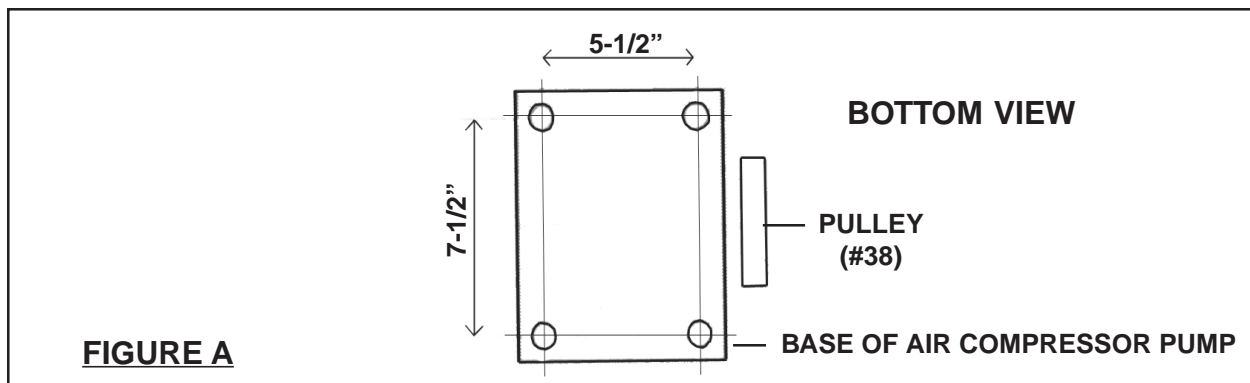

5. Once the four 3/8" mounting holes are drilled through the mounting surface, place the Air Compressor Pump on the mounting surface and align its four mounting holes with the four drilled mounting holes on the mounting surface. Then, secure the Air Compressor Pump to the mounting surface, using four 3/8" Bolts of appropriate length, four Lockwashers, and four Nuts (all not included).
6. The Air Compressor Pump requires the use of a "V" Pulley Belt (not included). The "V" Pulley Belt should be no wider than 1-5/16" wide at its widest point and of appropriate length depending on the distance between the Air Compressor Pump's Pulley (part #38) and the 3 HP Motor's Pulley (not included). Once the "V" Belt Pulley is installed, its proper length is indicated by pushing down with your finger midway on the "V" Belt Pulley. The "V" Belt Pulley should not depress more than 1/2". (See Figure B.)

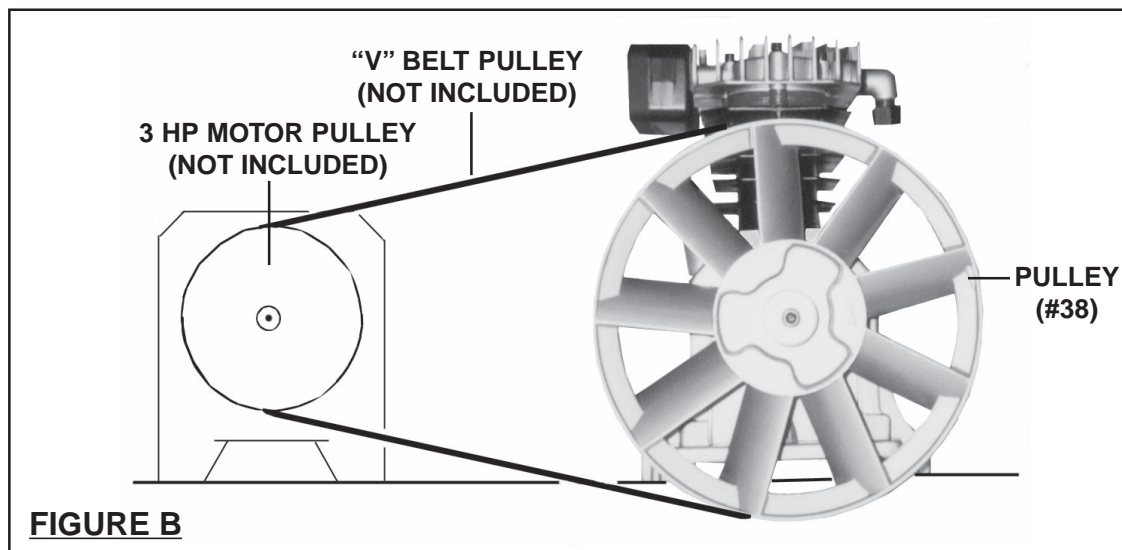

7. **WARNING!** To avoid personal injury and/or property damage, it is recommended that a properly functioning Pulley/Belt Guard (not included) be installed. The Pulley/Belt Guard should *fully* enclose (front, back, top, bottom) the Air Compressor Pump's Pulley (part #38), the "V" Belt, and the Motor's Pulley. **NOTE:** Make sure to allow for about 1" clearance, on all sides, between the Pulley/Belt Guard and the Air Compressor Pump's Pulley, the "V" Belt, and the Motor's Pulley. (See Figure C.)

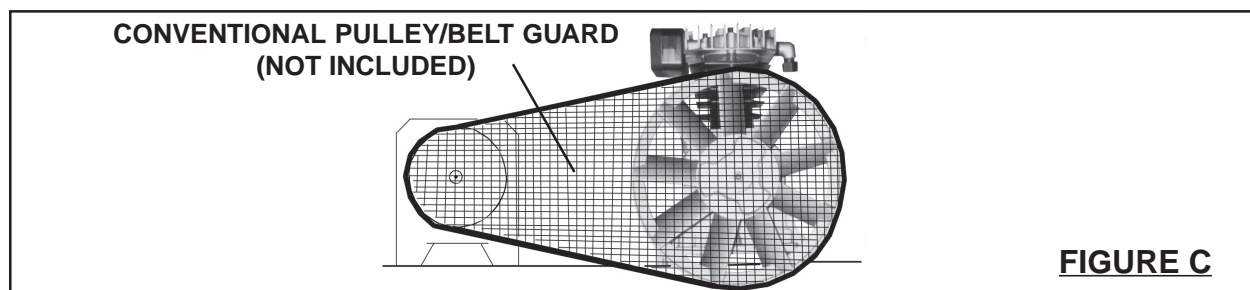

8. Attach the Air Compressor Tank's Inlet Hose (not included) to the 1/2" by 14-TPI Exhaust Elbow (part #3). **NOTE:** Make sure to wrap the male threads of Tank's Inlet Hose *Connector* with pipe seal tape (not included). Then, screw the Connector firmly into the Exhaust Elbow. **(See Figure D.)**

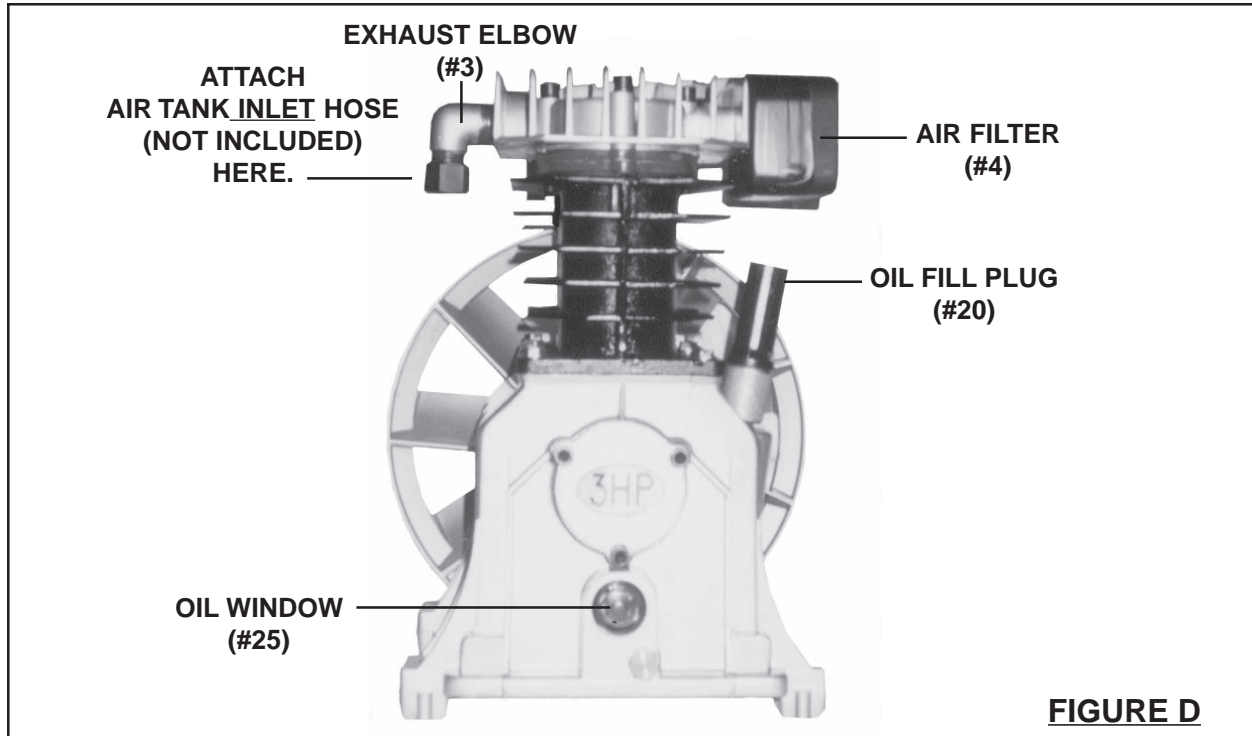

OPERATING INSTRUCTIONS

NOTE: For additional references to the parts mentioned in the following pages, refer to the **Assembly Diagram on page 10.**

To Check The Oil Level:

1. The Oil Window (part #25) is used to determine if oil is needed. To check the oil, observe the Oil Window. The oil should appear at the midway point (horizontally) in the circle of the Oil Window. **(See Figure D.)**

Note: The optimal capacity of the oil tank is 28.73 ounces.

2. If the oil level is below the midway point in the Oil Window (part #25) then it is necessary to add a *premium quality, 30-weight, non-detergent oil* until the level of oil reaches the midway point in the Oil Window. Do not overfill. **NOTE:** Make sure to **unscrew** the Oil Fill Plug and remove it from its Oil Fill Hole. Add the new oil. Then **screw** the Oil Fill Plug back into the Oil Fill Hole, being careful not to strip the threads. **(See Figure D.)**

3. Start the Air Compressor, and visually check the “V” Belt for proper tension. Also check for air leaks in the system, abnormal noise or vibration. If a problem occurs immediately disconnect the Air Compressor from its electrical supply source, release all air pressure from the system, and have the problem corrected before further use.
4. **IMPORTANT:** After starting the Air Compressor Pump, it should run for about **30 minutes without a load** in order for it to build up sufficient air pressure.

INSPECTION, MAINTENANCE, AND CLEANING

1. **WARNING!** Before performing any inspection, maintenance, and cleaning procedures, make sure all air pressure has been released from the Air Compressor’s Tank and that the Air Compressor is unplugged from its electrical outlet.
2. **BEFORE EACH USE,** inspect the general condition of the Air Compressor Pump. Check all air fittings for leaks. Check for loose screws, misalignment or binding of moving parts, cracked or broken parts, and any other condition that may affect the safe operation of this equipment. If abnormal noise or vibration occurs, immediately disconnect the Air Compressor from its electrical supply source and have the problem corrected before further use.
Do not use damaged equipment.
3. **DAILY:** Check the Air Compressor Pump’s oil level. If necessary, fill with a premium quality, 30-weight, non-detergent oil. **NOTE:** When checking the oil level, make sure to **unscrew** (do not pull) the Oil Fill Plug (part #20).
(See Figure D.)
4. **EVERY 100 HOURS OF USE:** Clean the Air Filter Element (part #4) with a mild solvent. Then, dry and re-attach the Air Filter Element. **NOTE:** Replace the Air Filter Element if it is too dirty to properly clean. **(See Assy. Diagram.)**
5. **EVERY 500 HOURS OR 12 MONTHS:** Replace the old oil with new, premium quality, 30-weight, non-detergent oil.
6. **TO CLEAN:** wipe with a damp cloth, using a mild detergent or mild solvent.
7. **WHEN STORING:** Keep the Air Compressor Pump in a clean, dry location.

PLEASE READ THE FOLLOWING CAREFULLY

THE MANUFACTURER AND/OR DISTRIBUTOR HAS PROVIDED THE PARTS LIST AND ASSEMBLY DIAGRAM IN THIS MANUAL AS A REFERENCE TOOL ONLY. NEITHER THE MANUFACTURER OR DISTRIBUTOR MAKES ANY REPRESENTATION OR WARRANTY OF ANY KIND TO THE BUYER THAT HE OR SHE IS QUALIFIED TO MAKE ANY REPAIRS TO THE PRODUCT, OR THAT HE OR SHE IS QUALIFIED TO REPLACE ANY PARTS OF THE PRODUCT. IN FACT, THE MANUFACTURER AND/OR DISTRIBUTOR EXPRESSLY STATES THAT ALL REPAIRS AND PARTS REPLACEMENTS SHOULD BE UNDERTAKEN BY CERTIFIED AND LICENSED TECHNICIANS, AND NOT BY THE BUYER. THE BUYER ASSUMES ALL RISK AND LIABILITY ARISING OUT OF HIS OR HER REPAIRS TO THE ORIGINAL PRODUCT OR REPLACEMENT PARTS THERETO, OR ARISING OUT OF HIS OR HER INSTALLATION OF REPLACEMENT PARTS THERETO.

PARTS LIST

Part #	Description	Qty.	Part #	Description	Qty.
1	Screw	6	21	Bolt	3
2	Cylinder Head	1	22	Crankcase Front Cover	1
3	Exhaust Elbow	1	23	Crankcase Front Washer	1
4	Air Filter	1	24	O-Ring	1
5	Spring Washer	2	25	Oil Window	1
6	Screw	2	26	Oil Drain Plug	1
7	Cylinder Head Washer	1	27	O-Ring	1
8	Valve Plate Seat	2	28	Crankcase Seal	1
9	Valve Plate	4	29	Crankcase Down Cover	1
10	Aluminum Washer	1	30	Bolt	8
11	Cylinder Up Washer	2	31	Crankcase	1
12	Piston Ring Assembly	2	32	Bearing	2
13	Piston	2	33	Crankshaft	1
14	Piston Pin	2	34	Crankcase Back Washer	1
15	Retaining Ring In Hole	4	35	Oil Seal	1
16	Connect Rod Assembly	2	36	Crankcase Back Cover	1
17	Bolt	6	37	Bolt	3
18	Cylinder	1	38	Pulley	1
19	Cylinder Down Washer	1	39	Large Washer	1
20	Oil Fill Plug	1	40	Bolt	1

NOTE: Some parts are listed and shown for illustration purposes only, and are not available individually as replacement parts.

ASSEMBLY DIAGRAM

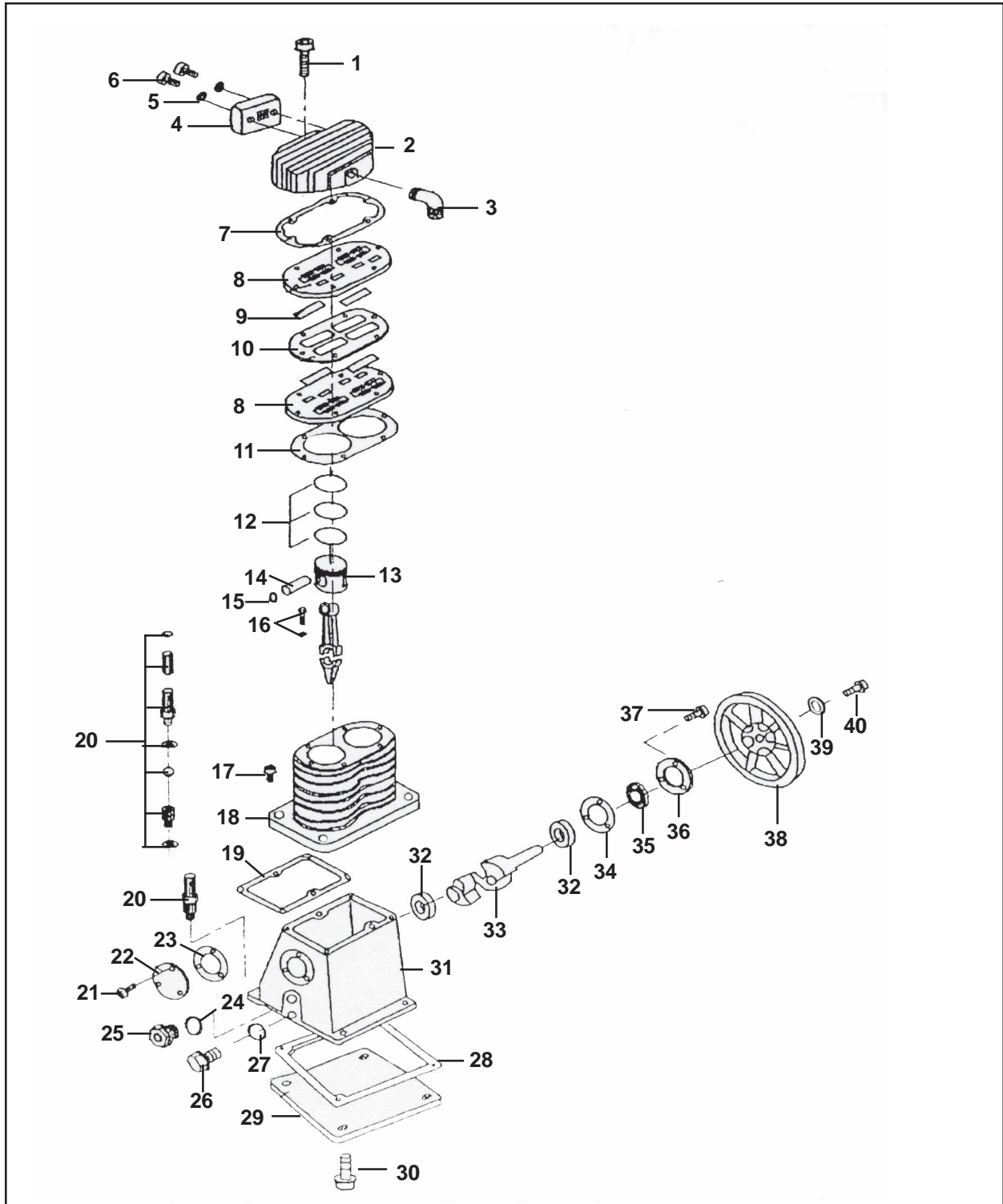

NOTE: Some parts are listed and shown for illustration purposes only, and are not available individually as replacement parts.

Free Manuals Download Website

<http://myh66.com>

<http://usermanuals.us>

<http://www.somanuals.com>

<http://www.4manuals.cc>

<http://www.manual-lib.com>

<http://www.404manual.com>

<http://www.luxmanual.com>

<http://aubethermostatmanual.com>

Golf course search by state

<http://golfingnear.com>

Email search by domain

<http://emailbydomain.com>

Auto manuals search

<http://auto.somanuals.com>

TV manuals search

<http://tv.somanuals.com>