

LIFT EXTENSION WINGS

(For Use With Model 94813 Motorcycle Lift)

Model 94830

ASSEMBLY INSTRUCTIONS

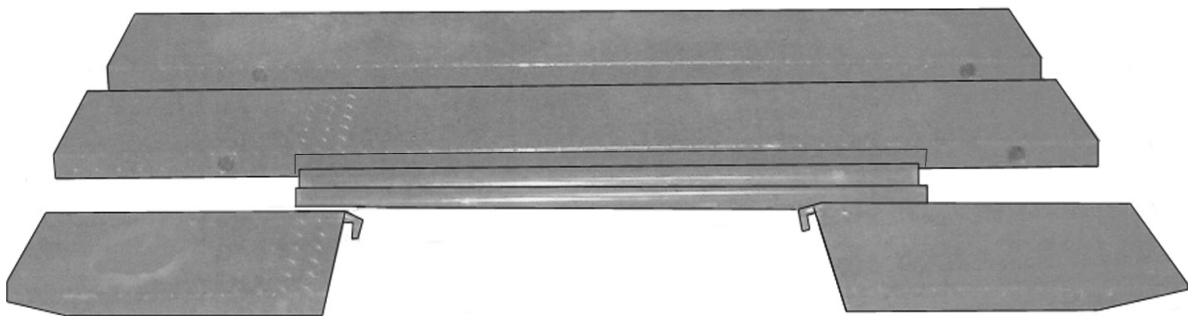

Due to continuing improvements, actual product may differ slightly from the product described herein.



3491 Mission Oaks Blvd., Camarillo, CA 93011
Visit our Web site at: <http://www.harborfreight.com>

**TO PREVENT SERIOUS INJURY,
READ AND UNDERSTAND ALL WARNINGS
AND INSTRUCTIONS BEFORE USE.**

Copyright© 2006 by Harbor Freight Tools®. All rights reserved. No portion of this manual or any artwork contained herein may be reproduced in any shape or form without the express written consent of Harbor Freight Tools.

For technical questions, please call 1-800-444-3353.

PRODUCT SPECIFICATIONS

Maximum Weight Capacity	1,200 Pounds
Side Extension Dimensions	78-3/4" Long x 10" Wide x 2" Thick
Ramp Extension Dimensions	21-3/4" Long x 10" Wide x 1-5/8" Thick
Net Weight	123.5 Pounds

SAVE THIS MANUAL

You will need this manual for the safety warnings and precautions, assembly, operating, inspection, maintenance and cleaning procedures, parts list and assembly diagram. Keep your invoice with this manual. Write the invoice number on the inside of the front cover. Keep this manual and invoice in a safe and dry place for future reference.

UNPACKING

When unpacking, check to make sure all the parts shown in the **Parts Lists on page 9** are included. If any parts are missing or broken, please call Harbor Freight Tools at the number shown on the front cover of this manual as soon as possible.

GENERAL SAFETY RULES

IMPORTANT SAFETY INSTRUCTIONS



READ AND UNDERSTAND ALL INSTRUCTIONS
Failure to follow all instructions detailed in this manual may result in serious personal injury.
SAVE THESE INSTRUCTIONS

WORK AREA

1. **Keep your work area clean and well lit.** Cluttered and dark work areas invite accidents.

2. **Keep bystanders, children, and visitors away while assembling and using the Extension Wings.** Distractions can cause you to lose control.

PERSONAL SAFETY

3. **Stay alert.** Watch what you are doing, and use common sense during use. Do not use the Motorcycle Lift while tired or under the influence of drugs, alcohol, or medication. A moment of inattention while operating power tools may result in serious personal injury.
4. **Dress properly.** Do not wear loose clothing or jewelry. Contain long hair. Keep your hair, clothing, and gloves away from moving parts. Loose clothes, jewelry, or long hair can be caught in moving parts.
5. **Do not overreach.** Keep proper footing and balance at all times. Proper footing and balance enables better control in unexpected situations.
6. **Always wear eye protection.** Wear ANSI approved safety impact eye glasses, when using this product.

TOOL USE AND CARE



7. **Store idle tools and equipment out of reach of children and other untrained people.** Tools and equipment are dangerous in the hands of untrained users.
8. **Maintain this product with care.** Keep this product clean. Properly maintained equipment is easier to control. Do not use damaged equipment. Tag damaged equipment “**Do not use**” until repaired.
9. **Check for misalignment or binding of moving parts, loose or broken parts, and any other condition that may affect this product’s operation.** If damaged, have this product serviced before using. Many accidents are caused by poorly maintained tools and equipment.
10. **Use only accessories that are recommended by the manufacturer for your model.** Accessories that may be suitable for one product may become hazardous when used on another product.

SERVICE

11. **Product service must be performed only by qualified service technician.** Service or maintenance performed by unqualified personnel could result in a risk of injury.

13. **When servicing the Extension Wings, use only identical replacement parts.** Follow instructions in the “*Inspection, Maintenance, And Cleaning*” section of this manual. Use of unauthorized parts or failure to follow maintenance instructions may create a risk of injury.

SPECIFIC SAFETY RULES

1. **The Lift Extension Wings are designed only for use with the model 94813 Motorcycle Lift** (available from Harbor Freight Tools).
2. ** WARNING! Do not exceed the 1,200 pound maximum lifting capacity of this product.** Exceeding the maximum lifting capacity could cause personal injury and/or property damage. **Beware of dynamic loading!** Suddenly dropping a load onto this product may create, for a brief instant, an excess load which may result in damage to the product and/or personal injury.
3. **Industrial applications must follow OSHA requirements.**
4. **Store idle tools.** When not in use, store the Extension Wings in a clean, dry, safe location out of reach of children.
5. **Prior to using this product, make sure to read and understand all instructions and safety precautions as outlined in the model 94813 Motorcycle Lift manual.**
6. **Make sure any load being supported by the Extension Wings is well balanced.** Unbalanced loads may cause the lift to tip over, potentially causing serious personal injury and/or property damage.
7. **Always make sure the object being lifted is properly and safely secured prior to raising the object.**
8. **Always monitor the object being lifted so it does not rock back and forth.**
9. ** WARNING!** The warnings and cautions discussed in this manual cannot cover all possible conditions and situations that may occur. It must be understood by the operator that common sense and caution are factors which cannot be built into this product, but must be supplied by the operator.

SAVE THESE INSTRUCTIONS

ASSEMBLY INSTRUCTIONS

NOTE:

For further references to the parts mentioned in the following pages, see the Assembly Diagram on **page 9** of this manual.

Attach The Side Extensions To The Motorcycle Platform:

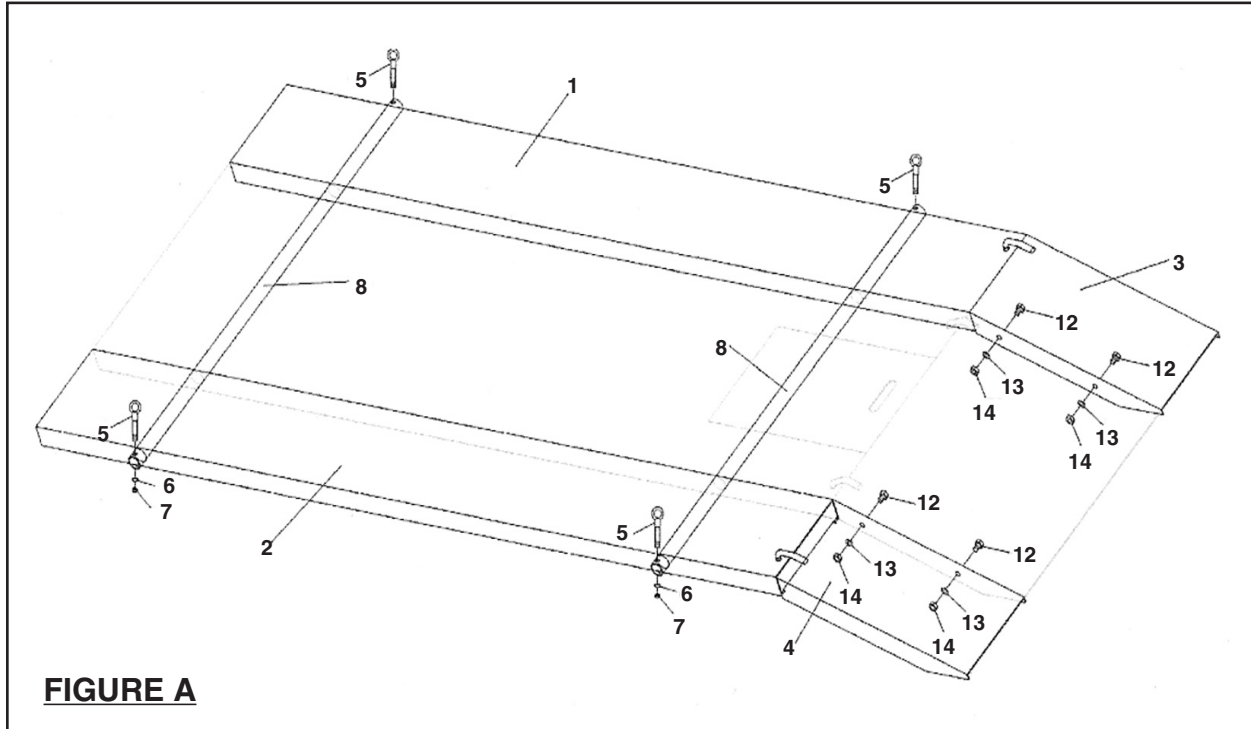

FIGURE A

1. With assistance, align the mounting hole in each end of the Left Side Extension (2) with the mounting hole in each end on the *left side* of the Platform.
2. Insert two Extension Panel Pipes (8) through the Left Side Extension (2) and the Motorcycle Platform.
3. With assistance, slide the Right Side Extension (1) onto the Extension Panel Pipes (8) and up against the Motorcycle platform.
4. Insert a Bolt (5) through each end of the two Extension Panel Pipes (8). Then secure the Extension Panel Pipes in place, using the Washers (6) and Nuts (7) provided.

Attach The Ramp Extensions To The Motorcycle Ramp:



1. With assistance, insert the hook on the Left Ramp Extension (4) into the mounting hole in the end of the Left Side Extension (2). **(See Figure A.)**
2. Align the two mounting holes under the Left Ramp Extension (4) with the two mounting holes in *left side* of the Ramp. Then secure the Left Ramp Extension to the Ramp, using two Bolts (12), two Washers (13), and two Nuts (14). **(See Figure A.)**
3. Align the two mounting holes in the Right Ramp Extension (3) with the two mounting holes in the *right side* of the Ramp. Then secure the Right Ramp Extension to the Ramp, using two Bolts (12), two Washers (13), and two Nuts (14). **(See Figure A.)**

Attach The Stabilizer Bar To The Motorcycle Lift Frame:

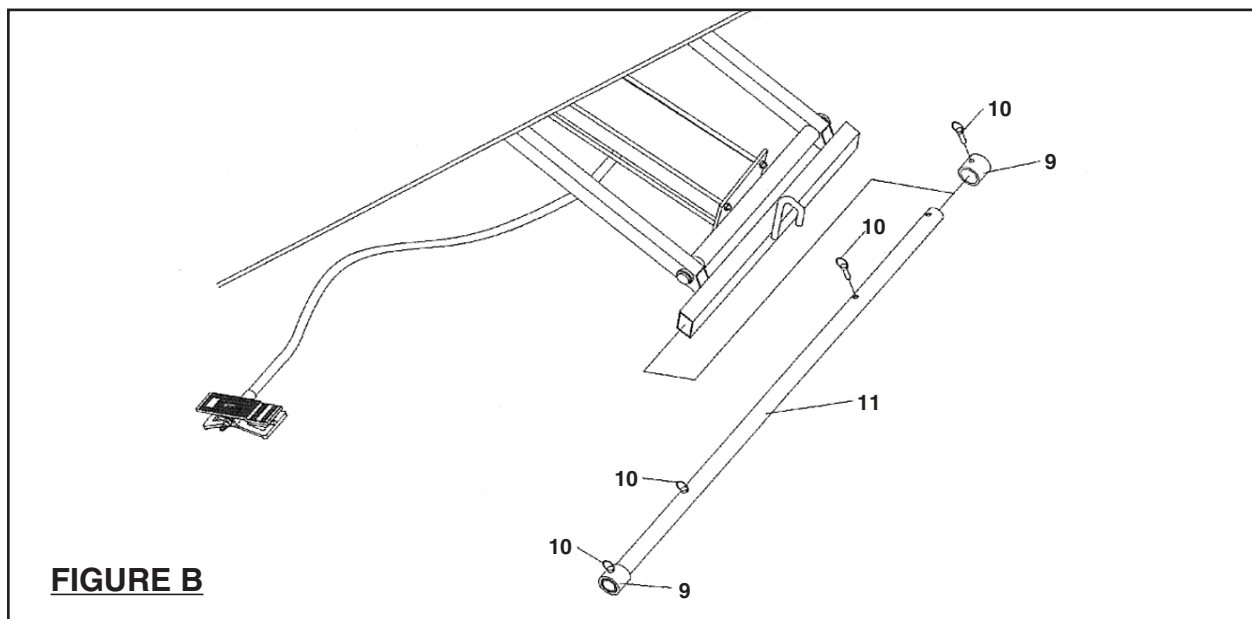
1. Insert the Stabilizer Bar (11) through the bottom/front frame of the Motorcycle Lift. **(See Figure B.)**
2. Align the two innermost mounting holes under the Stabilizer Bar (11) with the two mounting holes in the bottom/front frame of the Motorcycle Lift. Then secure the Stabilizer Bar to the frame, using two Pins (10). **(See Figure B.)**
3. Slide a Pipe Cap (9) onto each end of the Stabilizer Bar (11). Then secure the Pipe Caps to the Stabilizer Bar, using one Pin (10) for each Pipe Cap. **(See Figure B.)**



OPERATING INSTRUCTIONS

1.  **WARNING!** Do not exceed the maximum lifting capacity of the Extension Wings (1,200 pounds). Exceeding the maximum lifting capacities could cause personal injury and/or property damage.
2.  **WARNING!** Follow all instructions and safety precautions as outlined in the model 94813 Motorcycle Lift manual.
3. Make sure the Platform of the Motorcycle Lift is fully collapsed to the floor. Also, make sure the Removable Plate of the Motorcycle Lift is properly positioned over the inspection hole of its Platform.
4. With assistance, roll the object to be raised up the Right and Left Ramp Extensions (3, 4) and onto the Right and Left Side Extensions (1, 2).
5. You should stabilize the object using tie-down straps (not included) on each side of the motorcycle with one end of the straps tied to the object and the other end of the straps tied to the Right and Left Side Extensions (1, 2).
6. Connect an air hose to the Motorcycle Lift's Foot Air Valve. Then set the air compressor's regulator between 100 and 120 PSI. Do not exceed 120 PSI.
7. Step on and hold down the **right** side of the Motorcycle Lift's Foot Air Valve to raise the Lift.
8. When the Motorcycle Lift has been raised to the working height, lower its Safety Bar completely to prevent the Lift from accidentally lowering.
9. When work on the motorcycle is completed, check under the Motorcycle Lift to make sure there are no tools, parts, etc. and that it is safe to lower the Lift.
10. Remove the Safety Bar. Then step on and hold down the **left** side of the Motorcycle Lift's Foot Air Valve to *slowly* lower the Lift to the floor.
11. With assistance, remove the tie-down straps from the object. Then, slowly back the object completely off the Motorcycle Lift.
12. Turn off the air compressor. Step on and hold down the **left** side of the Motorcycle Lift's Foot Air Valve to release any remaining compressed air in the system. Then, disconnect the compressor's air hose from the Foot Air Valve.
13. Make sure to store the Motorcycle Lift and its Extension Wings in a clean, dry, safe location out of reach of children and other unauthorized people.

INSPECTION, MAINTENANCE, AND CLEANING

1. **Before each use:** Inspect the general condition of the Extension Wings. Check for cracked, worn or damaged parts, loose or missing parts, and any other condition that may affect the product's safe operation. If a problem occurs, have the problem corrected before further use.
Do not use damaged equipment.
2. **To clean:** Use a damp cloth and a mild detergent. Do not use solvents or other flammable agents.
3. **When storing:** Keep the Extension Wings in a clean, dry, safe location out of reach of children and other unauthorized people.
4.  **CAUTION!** All maintenance, service, and repairs not discussed in this manual should only be performed by a qualified service technician.

PLEASE READ THE FOLLOWING CAREFULLY

THE MANUFACTURER AND/OR DISTRIBUTOR HAS PROVIDED THE PARTS LIST AND ASSEMBLY DIAGRAM IN THIS MANUAL AS A REFERENCE TOOL ONLY. NEITHER THE MANUFACTURER OR DISTRIBUTOR MAKES ANY REPRESENTATION OR WARRANTY OF ANY KIND TO THE BUYER THAT HE OR SHE IS QUALIFIED TO REPLACE ANY PARTS OF THE PRODUCT. IN FACT, THE MANUFACTURER AND/OR DISTRIBUTOR EXPRESSLY STATES THAT ALL REPAIRS AND PARTS REPLACEMENTS SHOULD BE UNDERTAKEN BY CERTIFIED AND LICENSED TECHNICIANS, AND NOT BY THE BUYER. THE BUYER ASSUMES ALL RISKS AND LIABILITY ARISING OUT OF HIS OR HER REPAIRS TO THE ORIGINAL PRODUCT OR REPLACEMENT PARTS THERETO, OR ARISING OUT OF HIS OR HER INSTALLATION OF REPLACEMENT PARTS THERETO.

PARTS LIST AND ASSEMBLY DIAGRAM

Part	Description	Qty.
1	Side Extension (Right)	1
2	Side Extension (Left)	1
3	Ramp Extension (Right)	1
4	Ramp Extension (Left)	1
5	Bolt	4
6	Washer	4
7	Nut	4

Part	Description	Qty.
8	Extension Panel Pipe	2
9	Pipe Cap	2
10	Pin	4
11	Stabilizer Bar	1
12	Bolt	4
13	Washer	4
14	Nut	4

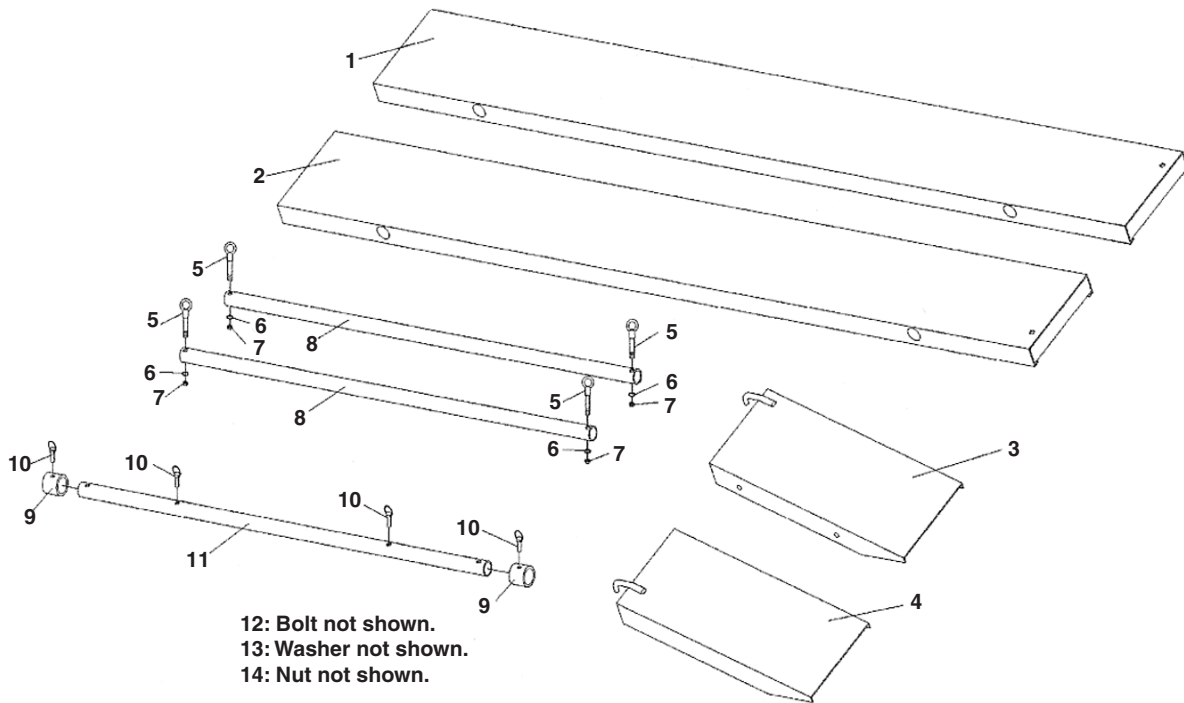

NOTE:

Some parts are listed and shown for illustration purposes only, and are not available individually as replacement parts.

Free Manuals Download Website

<http://myh66.com>

<http://usermanuals.us>

<http://www.somanuals.com>

<http://www.4manuals.cc>

<http://www.manual-lib.com>

<http://www.404manual.com>

<http://www.luxmanual.com>

<http://aubethermostatmanual.com>

Golf course search by state

<http://golfingnear.com>

Email search by domain

<http://emailbydomain.com>

Auto manuals search

<http://auto.somanuals.com>

TV manuals search

<http://tv.somanuals.com>