

CENTRAL PNEUMATIC®

Air Palm Nailer

Model 93496

ASSEMBLY AND OPERATING INSTRUCTIONS

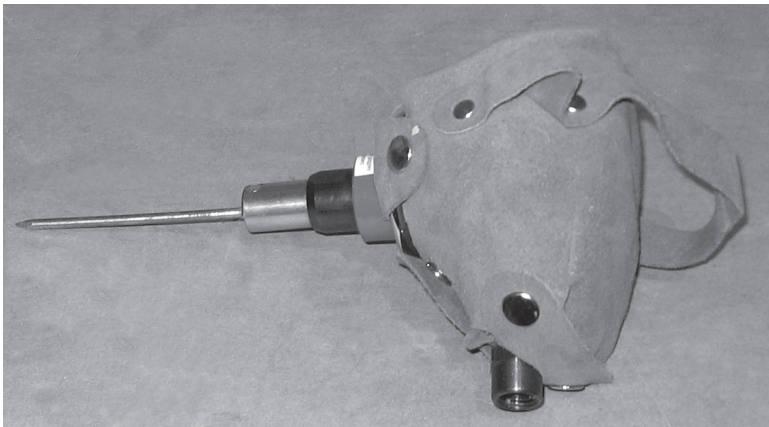

Due to continuing improvements, actual product may differ slightly from the product described herein.



3491 Mission Oaks Blvd., Camarillo, CA 93011

Visit our Web site at <http://www.harborfreight.com>

Copyright © 2005 by Harbor Freight Tools®. All rights reserved. No portion of this manual or any artwork contained herein may be reproduced in any shape or form without the express written consent of Harbor Freight Tools.

For technical questions and replacement parts, please call 1-800-444-3353

Specifications

Construction:	Cast Aluminum Frame, Steel Air Inlet and Magnetic Steel Nail Holder.	Max. Nail Length and Gauge:	3-1/2"L x 8 gauge (nails not included)
Air Inlet Dimensions:	1/4" 18NPT Female Inlet	Driver Stroke and Impacts per Minute:	1/4" stroke, 1,000 Blows Per Minute
Air Consumption:	2 - 4 cfm	Operating Air Pressure:	70 - 125psi *
Overall Dimensions:	3-1/4"W x 4-3/4"L x 5-1/4"H	Net Weight:	2.65 Lbs.

***The air pressure setting must not exceed job site regulations/restrictions. The air pressure setting must not exceed 90 PSI when being used with work pieces that have a thickness of less than 1-3/4".**

Save This Manual

You will need the manual for the safety warnings and precautions, assembly instructions, operating and maintenance procedures, parts list and diagram. Keep your invoice with this manual. Write the invoice number on the inside of the front cover. Keep the manual and invoice in a safe and dry place for future reference.



Safety Warnings and Precautions

WARNING: When using tool, basic safety precautions should always be followed to reduce the risk of personal injury and damage to equipment.

Read all instructions before using this tool!

1. **Keep work area clean.** Cluttered areas invite injuries.
2. **Observe work area conditions.** Do not use machines or power tools such as air compressor in damp or wet locations. Do not expose to rain. Keep work area well lit. Do not use electrically powered tools in the presence of flammable gases or liquids.
3. **Keep children away.** Children must never be allowed in the work area. Do not let them handle machines, tools, or extension cords.
4. **Store idle equipment.** When not in use, tools must be stored in a dry location to inhibit rust. Always lock up tools and keep out of reach of children.
5. **Use the right tool for the job.** Do not attempt to force a small tool or attachment to do the work of a larger industrial tool. There are certain applications for which this tool was designed. It will do the job better and more safely at the rate for which it was intended. Do not modify this tool and do not use this tool for a purpose for which it was not intended.

- 6. Dress properly while working.** Do not wear loose clothing or jewelry as they can be caught in moving parts. Protective, electrically non-conductive work clothes and non-skid footwear are recommended when working. Wear restrictive hair covering to contain long hair. Always wear work boots and work gloves.



- 7. Use eye and ear protection.** Always wear ANSI approved impact safety goggles. Wear a full face shield if you are producing metal filings or wood chips. Wear an ANSI approved dust mask or respirator when working around metal, wood, and chemical dusts and mists.

- 8. Do not overreach.** Keep proper footing and balance at all times. Do not reach over or across running machines.
- 9. Maintain tools with care.** Keep tools clean and in good condition for better and safer performance. Follow instructions for lubricating and changing accessories. Inspect tool fittings and hoses periodically and, if damaged, have them repaired by an authorized technician. The handles must be kept clean, dry, and free from oil and grease at all times.
- 10. Disconnect Air Hose and release any built-up air pressure.** Never service the Nailer, clear jams, or disassemble with the air hose attached. Always release any built-up air even after disconnecting hose. Disconnect the Nailer when not in use.
- 11. Remove adjusting keys and wrenches.** Check that keys and adjusting wrenches are removed from the tool or machine work surface before connecting it.
- 12. Avoid unintentional starting.** Be sure the switch is in the Off position when not in use and before attaching to pressure source. Do not carry any tool with your finger on the trigger, whether it is attached or not.
- 13. Stay alert.** Watch what you are doing, use common sense. Do not operate any tool when you are tired.
- 14. Check for damaged parts.** Before using any tool, any part that appears damaged should be carefully checked to determine that it will operate properly and perform its intended function. Check for alignment and binding of moving parts; any broken parts or mounting fixtures; and any other condition that may affect proper operation. Any part that is damaged should be properly repaired or replaced by a qualified technician. Do not use the tool if any switch does not turn On and Off properly.
- 15. Guard against electric shock when working on electrical equipment.** Prevent body contact with grounded surfaces such as pipes, radiators, ranges, and refrigerator enclosures.

16. **Replacement parts and accessories.** When servicing, use only identical replacement parts. Use of any other parts will void the warranty. Only use accessories intended for use with this tool. Approved accessories are available from Harbor Freight Tools.
17. **Do not operate tool if under the influence of alcohol or drugs.** Read warning labels on prescriptions to determine if your judgment or reflexes are impaired while taking drugs. If there is any doubt, do not operate the tool.
18. **Use proper size and type air pressure line and fittings.** The recommended air line for this tool is 3/8" delivering no more than 125 psi. Recommended air inlet size is 1/4" - 18 npt.
19. **Maintenance.** For your safety, service and maintenance should be performed regularly by a qualified technician.
20. **Compressed air only.** Never use combustible gas as a power source.



21. **Do not put a nail into the Air Palm Nailer until you are ready to work.** Do not point the Air Nailer toward any person or animal. Severe injury may result in case of accidental ejection of a nail.
22. **Disconnect air supply when done working.** Before storing or making any adjustments to the Nailer make sure that the compressed air is disconnected.
23. **Fire fasteners into an appropriate work surface only.** Do not attempt to fire fasteners into surfaces too hard to penetrate. Do not drive fasteners on top of other fasteners, or at too steep of an angle. Fasteners can ricochet causing personal injury. Never fire the Nailer into the air, or point it toward yourself or another person. Always wear ANSI approved safety goggles during use, maintenance, and reloading.
24. **Do not fire fasteners too close to the edge of a workpiece.** They may split the workpiece and fly free, causing personal injury.

WARNING: Some dust created by power sanding, sawing, grinding, drilling, and other construction activities, contain chemicals known [to the State of California] to cause cancer, birth defects or other reproductive harm. Some examples of these chemicals are:

Lead from lead-based paints

Crystalline silica from bricks and cement or other masonry products

Arsenic and chromium from chemically treated lumber

(California Health & Safety Code 25249.5, *et seq.*)

WARNING: The Brass components of this product contain Lead, a chemical known to the state of California to cause birth defects (or other reproductive harm). (Calif. Health & Safety Code 25545.5 *et seq.*)

Warning: The warnings, cautions, and instructions discussed in this instruction manual cannot cover all possible conditions and situations that may occur. It must be understood by the operator that common sense and caution are factors which cannot be built into this product, but must be supplied by the operator.

Air Pressure Supply

This tool is designed to operate with a maximum air pressure of 125 psi. You must use an air regulator, set at 125 psi or below. **Note:** Performance of this tool may vary depending on variations in local air pressure.

In use, this tool will use 2 - 4 Cubic Feet per Minute of compressed air at 125 psi. For satisfactory performance, you must use an air compressor capable of delivering this volume of air at the stated pressure.

We recommend that you use both a filter and an in-line oiler in your air supply system as illustrated in the diagram below. These components are not included with this tool, but are available from Harbor Freight Tools.

If you do not use a filter and in-line oiler, put a few drops of water displacement oil into the air line before each use. After each use, the Air Hand Nailer should be carefully drained of collected moisture and sprayed with a water displacement oil.

We recommend that you install a quick-release nipple (not included) into the Air Inlet (23). Quick release connectors at all points in an air pressure system make your work easier.

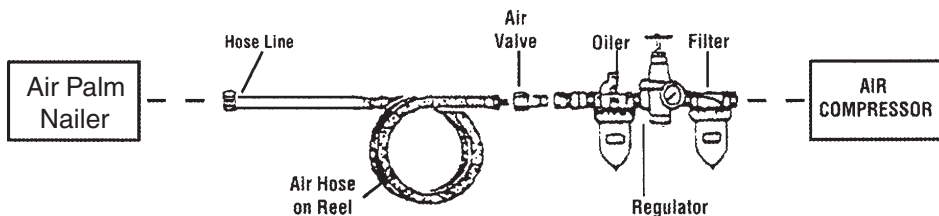

Recommended Air Line Components

Unpacking

When unpacking, check to make sure the following parts are included.

*Air Palm Nailer Tool
Leather Cover
(1) 4mm Hex Key*

If any parts are missing or broken, please call Harbor Freight Tools at the number on the cover of this manual.

Operation

NOTE: This tool is assembled when you receive it, and may be used immediately. However, we recommend that you install a quick disconnect adapter (not included) to the Air Inlet (23) before use.

WARNING: Do not put a nail into the Air Palm Nailer until you are ready to work.

WARNING: Do not point the Air Palm Nailer toward any person or animal. Severe injury may result in case of accidental ejection of a nail.

1. Attach the air supply hose (not included) to the tool.
2. Grip the base of the tool in one hand. Note that there is a hand strap and thumb strap on the Leather Cover (25) to facilitate holding the tool.

CAUTION: Whenever using this tool wear ANSI approved safety goggles.

3. When ready to work, hold a nail by the shaft, and place the flat head into the Hammer Tip (3). The nail will be held in place by the magnetic tip.
4. Place the pointed end of the nail where desired on the workpiece. Keep your free hand away from the tool and the nail.
5. Press the tool straight down. This will trigger the tool and cause it to hammer the nail. Continue pressing down until the nail is driven all the way in.
6. You can adjust the force of the tool's impact by adjusting the air pressure. However, do not operate the tool at more than 125 psi.

CAUTION: Disconnect the tool from air pressure supply when not in use, and before making any adjustments.

7. During operation, the Hammer Tip will hammer 1/4" up to 1,000 times per minute. This tool is useful for driving nails in tight areas where a full sized air nail gun may not reach.
8. When the nail is hammered all the way down, the tool will stop operating. To stop the tool, release the downward pressure on the Hammer Tip.

Maintenance

1. Place a few drops of light weight air tool oil (not included) into the Air Inlet (23) each time before using the tool.
2. After each use, drain any accumulated moisture from the tool, and spray a small amount of water displacing oil into and on the tool. Wipe clean.
3. Store tool in a safe location out of reach of children and unauthorized persons.

Troubleshooting

Tool will not operate.

1. **Possible cause:** Low or no air pressure.
Solution: Check air compressor to be sure it is operating properly. Check Air Regulator. Check air lines for leaking or blockage.
2. **Possible cause:** Corroded Piston (8).
Solution: Spray light weight penetrating oil into the Air Inlet (23). If tool still won't operate, take it to a qualified service technician for repair.
3. **Possible Cause:** Damaged Seals or O rings.
Solution: Take it to a qualified service technician for repair.

Note: A hex wrench is included for removing hex bolts when removing the Rear Cover (18). This work should only be done by a qualified service technician.

Parts List

Part #	Description	QTY.	Part #	Description	QTY.
1	Body	1	14	Rubber Ring	1
2	Guide Box	1	15	O Ring	1
3	Hammer Tip	1	16	Valve	1
4	Spring Washer	1	17	O Ring	1
5	Spring	1	18	Rear Cover	1
6	Rubber Damper	1	19	Valve Packing	1
7	O Ring	1	20	O Ring	1
8	Piston	1	21	Gasket	1
9	Piston Rod	1	22	Hex Bolt	4
10	O Ring	1	23	Air Inlet	1
11	O Ring	1	24	Hex Wrench	1
12	Cylinder	1	25	Leather Cover (not shown)	1
13	Cylinder Cover	1			

NOTE: Some parts are listed and shown for illustration purposes only and are not available individually as replacement parts.

Assembly Drawing

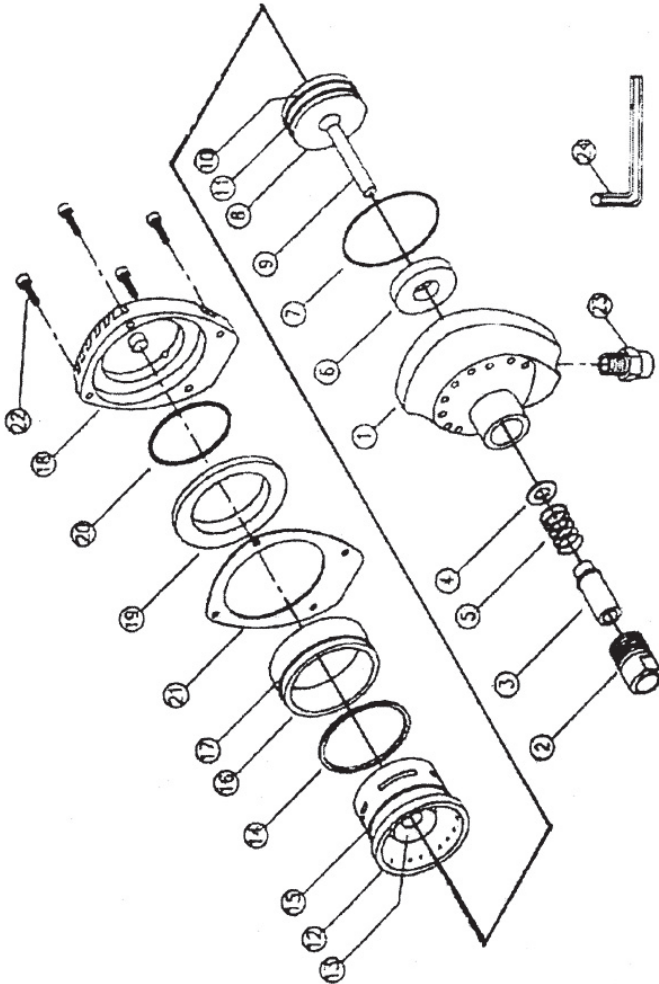

PLEASE READ THE FOLLOWING CAREFULLY

THE MANUFACTURER AND/OR DISTRIBUTOR HAS PROVIDED THE PARTS DIAGRAM IN THIS MANUAL AS A REFERENCE TOOL ONLY. NEITHER THE MANUFACTURER NOR DISTRIBUTOR MAKES ANY REPRESENTATION OR WARRANTY OF ANY KIND TO THE BUYER THAT HE OR SHE IS QUALIFIED TO MAKE ANY REPAIRS TO THE PRODUCT OR THAT HE OR SHE IS QUALIFIED TO REPLACE ANY PARTS OF THE PRODUCT. IN FACT, THE MANUFACTURER AND/OR DISTRIBUTOR EXPRESSLY STATES THAT ALL REPAIRS AND PARTS REPLACEMENTS SHOULD BE UNDERTAKEN BY CERTIFIED AND LICENSED TECHNICIANS AND NOT BY THE BUYER. THE BUYER ASSUMES ALL RISK AND LIABILITY ARISING OUT OF HIS OR HER REPAIRS TO THE ORIGINAL PRODUCT OR REPLACEMENT PARTS THERETO, OR ARISING OUT OF HIS OR HER INSTALLATION OF REPLACEMENT PARTS THERETO.

Free Manuals Download Website

<http://myh66.com>

<http://usermanuals.us>

<http://www.somanuals.com>

<http://www.4manuals.cc>

<http://www.manual-lib.com>

<http://www.404manual.com>

<http://www.luxmanual.com>

<http://aubethermostatmanual.com>

Golf course search by state

<http://golfingnear.com>

Email search by domain

<http://emailbydomain.com>

Auto manuals search

<http://auto.somanuals.com>

TV manuals search

<http://tv.somanuals.com>