



## 20 OZ. AIR GRAVITY SPRAY GUN

Model 91009

### ASSEMBLY and OPERATING INSTRUCTIONS



3491 Mission Oaks Blvd., Camarillo, CA 93011  
Visit our Web site at <http://www.harborfreight.com>

Copyright © 2003 by Harbor Freight Tools®. All rights reserved. No portion of this manual or any artwork contained herein may be reproduced in any shape or form without the express written consent of Harbor Freight Tools.

**For technical questions and replacement parts, please call 1-800-444-3353**

## Specifications

Operating and Maximum PSI	40 PSI/ 50 PSI Max.
Average Air Consumption	5 CFM
Paint Capacity	20 oz.
Air Inlet	1/4" - 18 NPS
Nozzle Size	0.055"
Weight	1.5 Lbs. (when empty)

## Save This Manual

You will need the manual for the safety warnings and precautions, assembly instructions, operating and maintenance procedures, parts list and diagram. Keep your invoice with this manual. Write the invoice number on the inside of the front cover. Keep the manual and invoice in a safe and dry place for future reference.

## Safety Warnings and Precautions

**WARNING: When using tool, basic safety precautions should always be followed to reduce the risk of personal injury and damage to equipment.**

**Read all instructions before using this tool!**

1. **Keep work area clean.** Cluttered areas invite injuries.
2. **Observe work area conditions.** Do not use machines or power tools in damp or wet locations. Don't expose to rain. Keep work area well lit. Do not use air tools in the presence of flammable gases or liquids.
3. **Keep children away.** Children must never be allowed in the work area. Do not let them handle machines, tools, extension cords, or air hoses.
4. **Store idle equipment.** When not in use, tools must be stored in a dry location to inhibit rust. Always lock up tools and keep out of reach of children.
5. **Use the right tool for the job.** Do not attempt to force a small tool or attachment to do the work of a larger industrial tool. There are certain applications for which this tool was designed. It will do the job better and more safely at the rate for which it was intended. Do not modify this tool and do not use this tool for a purpose for which it was not intended.
6. **Dress properly.** Do not wear loose clothing or jewelry as they can be caught in moving parts. Protective, electrically non-conductive clothes and non-skid footwear are recommended when working. Wear restrictive hair covering to contain long hair.
7. **Use eye and ear protection.** Always wear ANSI approved impact safety goggles. Wear an ANSI approved dust mask or respirator when working around chemical dusts, paints and mists. Wear appropriate ear protection.

8. **Do not overreach.** Keep proper footing and balance at all times. Do not reach over or across running machines or air hoses.
9. **Maintain tools with care.** Keep tools clean for better and safer performance. Follow instructions for lubricating and changing accessories. Inspect tool cords and air hoses periodically and, if damaged, have them repaired by an authorized technician. The handles must be kept clean, dry, and free from oil and grease at all times.
10. **Disconnect air supply.** Disconnect air hose when not in use, when changing accessories, and during maintenance.
11. **Remove adjusting wrenches.** Check that adjusting wrenches are removed from the tool before attaching to the air source.
12. **Avoid unintentional starting.** Be sure the trigger is in the Off position when not in use and before attaching to the air source. Do not carry any tool with your finger on the trigger, whether it is attached to the air compressor or not.
13. **Stay alert.** Watch what you are doing, use common sense. Do not operate any tool when you are tired.
14. **Check for damaged parts.** Before using any tool, any part that appears damaged should be carefully checked to determine that it will operate properly and perform its intended function. Check for alignment and binding of moving parts; any broken parts or mounting fixtures; and any other condition that may affect proper operation. Any part that is damaged should be properly repaired or replaced by a qualified technician. Do not use the tool if any trigger does not operate properly.
15. **Guard against electric shock.** Prevent body contact with grounded surfaces such as pipes, radiators, ranges, and refrigerator enclosures.
16. **Replacement parts and accessories.** When servicing, use only identical replacement parts. Use of any other parts will void the warranty. Only use accessories intended for use with this tool. Approved accessories are available from Harbor Freight Tools.
17. **Do not operate tool if under the influence of alcohol or drugs.** Read warning labels if taking prescription medicine to determine if your judgement or reflexes are impaired while taking drugs. If there is any doubt, do not operate the tool.
18. **Use proper size and type extension cord.** If an extension cord is required, it must be of the proper size and type to supply the correct current to the compressor without heating up. Otherwise, the extension cord could melt and catch fire, or cause electrical damage to the compressor. Check your compressor's manual for the appropriate size cord.
19. **Maintenance.** For your safety, maintenance should be performed regularly by a qualified technician.
20. **Compressed air only.** Never use combustible gas as a power source.
21. **Do not spray near open flames, pilot lights, stoves, heaters, or any other heat source.** Most solvents and coatings are highly flammable, particularly when sprayed.

22. **Clean Sprayer with care. Use non-flammable solvents.**
23. **Do not smoke while spraying.** Most solvents and coatings are highly flammable, particularly when sprayed.
24. **Read all of the information concerning coating products and cleaning solvents.** Chlorinated solvents (e.g. 1-1-1 Trichlorethylene and Methylene Chloride, also known as methyl chloride) can chemically react with aluminum and may explode. Many paint sprayers contain aluminum. If you have any doubt about potential chemical reactions, contact the solvent or coating manufacturer.
25. **Materials used when painting or cleaning may be harmful or fatal if inhaled or swallowed.** Only use in an area with adequate ventilation. Use a respirator or mask when painting or using cleaning solvents.
26. **Never release the sprayer lid while the cup is pressurized.**
27. **Never point a spray gun at a person or animal.** Always properly mask all objects that are not to be painted.

**Note: Performance of the compressor (if powered by line voltage) may vary depending on variations in local line voltage. Extension cord usage may also affect tool performance.**

**Warning: The warnings, cautions, and instructions discussed in this instruction manual cannot cover all possible conditions and situations that may occur. It must be understood by the operator that common sense and caution are factors which cannot be built into this product, but must be supplied by the operator.**

**WARNING: The brass components of this product contain lead, a chemical known to the State of California to cause birth defects (or other reproductive harm). (California Health & Safety code 25249.5, et seq.)**

## Unpacking

When unpacking, check to make sure the parts listed on page 8 are included. If any parts are missing or broken, please call Harbor Freight Tools at the number on the cover of this manual as soon as possible.

## Operation

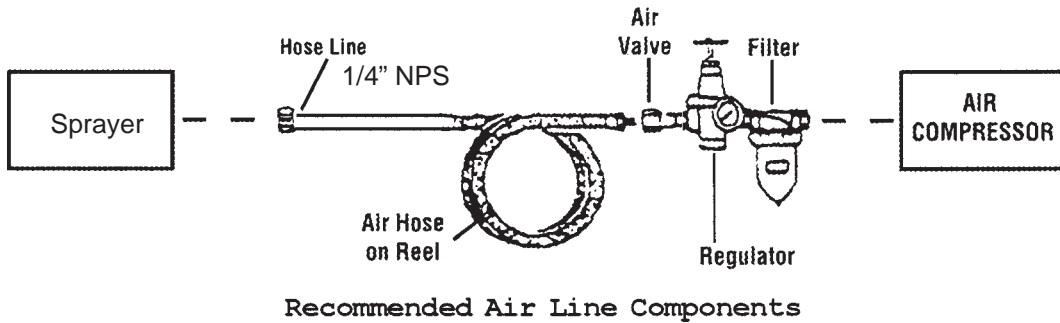

For best service you should incorporate a regulator and inline filter, as shown in the diagram above. Hoses, couplers, regulators, and filters are all available at Harbor Freight Tools.

1. You will need to prepare a 1/4" air connector (sold separately) to connect to the air inlet on the Spray Gun. First, wrap the 1/4" air connector (not included) with pipe thread seal tape before threading it into the Air Inlet (32). Connect the 3/8" ID Air Source Hose to the Spray Gun.
2. Set the air pressure on your compressor to 40 PSI. Do not exceed the maximum air pressure of 50 PSI.
3. Check the air connection for leaks and then disconnect the tool from the air source.

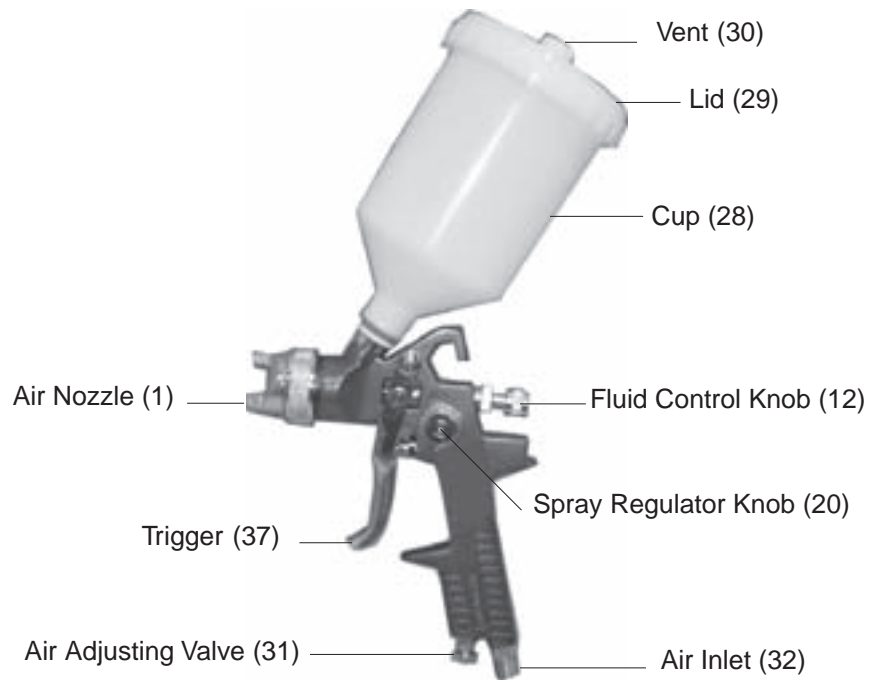

## Operation (continued)

### Filling the Cup (28)

**Warning!** The Spray Gun must be disconnected from the air source when filling or refilling material.

1. Attach the Cup (28) to the Spray Gun. Make sure to include the Filter (27) in between the Cup (28) and Gun Body (8) during assembly.
2. Remove the Lid (29) off the top of the Cup (28) of the Spray Gun.
3. Fill the Cup (28) with the appropriate material and replace the Lid (29) on the top of the Cup (28). Make sure the Lid (29) is securely tightened. Make sure the Vent (30) is closed.

**Note:** Before spraying, mask all objects you do not want sprayed and lay cloths (not included) on the floors.

## Operation

**Note:** We recommend you practice on scrap material to adjust and get familiar with the Gun.

1. Connect the air source hose to the Air Inlet (32). Turn on your air compressor to the recommended air pressure of 40 PSI. Do not exceed the 50 PSI maximum.
2. Pull the Trigger (36) slowly and move the Spray Gun in parallel strokes to the object being painted. Keep the distance from the object being painted at 4" to 12". This may slightly differ depending on the flow adjustment and the material being sprayed.
3. Release the Trigger (36) after each forward movement; pull the Trigger (36) again on the return movement.
4. When using a vertical pattern, move the Spray Gun in a horizontal motion; with a horizontal pattern move the Spray Gun in a vertical motion. A round pattern requires a greater distance from the object being painted.
5. When finished, release the Trigger (36) and disconnect from the air source. The Cup (28) and Spray Gun may still hold air pressure, fire the Spray Gun toward scrap material until all of the pressure is expended. Before removing the Lid (29), open the Vent (30).

### Spray Gun Adjustments (Refer to page 5 and the Assembly Drawing on page 9)

**Note:** We recommend you practice on scrap material to learn the fine tune adjustments.

1. To change the spray pattern, turn the Spray Regulating Knob (20) and/or adjust the Air Nozzle (1).
2. To regulate the amount of material entering the Spray Gun, adjust the Fluid Control Knob (12).
3. To fine tune the air flow, adjust the Air Adjusting Valve (31).

## Troubleshooting

**Note:** Have any of the following internal repairs completed by an authorized service technician.

Trouble	Cause	Repair
Gun leaks from fluid tip	Foreign substance between the fluid tip and needle preventing a good seal	Clean fluid needle in thinner or replace nozzle set
Spray pattern sickle shaped	Air circuit clogged	Soak in thinner and clean the nozzle set and internal needle
Spray pattern oval shaped	Dirt on fluid pin tip or air outlet	Turn the air nozzle 180°, clean fluid tip pin and air circuit
Spray pattern flutters	Not enough material in the cup, fluid nozzle not tight, needle sealing damaged, nozzle set dirty or damaged	Refill material, tighten parts, clean or replace parts
Material bubbles or boils in the paint cup	Too much air flowing through the paint channel to the cup, loose paint nozzle, loose air nozzle, clogged filter, defective gasket, or damaged nozzle insert	Clean, tighten, or replace parts

**Note:** To clean, change, or replace the Fluid Nozzle (2), use the Wrench (35) **FIGURE 2**, to the right.

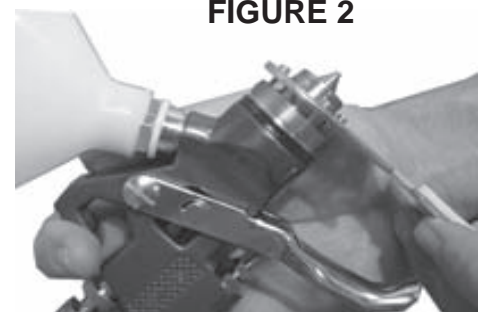

**FIGURE 2**

## Maintenance

Disconnect from the air source.

1. Remove the Lid (29).
2. Pour residual paint into the paint container and seal it.
3. Pour non-flammable paint thinner into the Cup (28).  
If water based paint was used, you can use water.
4. Secure the Lid (29) to the Cup (28) and shake the liquid in the cup.
5. Connect to the air source and turn on the air compressor.
6. Spray the liquid onto a piece of scrap material until the spray material is free of paint.
7. Repeat if necessary.
8. Remove the entire Cup (28) by un-threading it. Check the Filter (27) in the Gun Body (8). If it is not clean, use the Brush (33) to clean it. Replace the Filter (27) and thread on the Cup (28). See **FIGURE 3 on page 8**.
9. Use the Brush (33) to clean the recessed, hard to reach areas of the Gun.

## Parts List

Part No.	Description	Part No.	Description
1	Air Nozzle	20	Spray Regulator Knob
2	Fluid Nozzle	21	Screw
3	Air Ring	22	Trigger Bolt
4	Piston Pad	23	Locking Plate
5	Compression Ring	24	Bolt
6	Needle Seal Spring	25	Bolt
7	Air Piston Seal	26	Paint Connector
8	Gun Body	27	Filter
9	Paint Needle	28	Cup
10	Paint Piston Spring	29	Lid
11	Nut	30	Vent
12	Fluid Control Knob	31	Air Adjust. Valve Assy.
13	Air Piston Box	32	Air Inlet
14	Air Piston Packing	33	Brush
15	Air Piston	34	Hex Adapter
16	Piston Ring	35	Wrench
17	Air Piston	36	Trigger
18	Air Piston Spring		
19	Spray Regulator Screw		

**FIGURE 3**

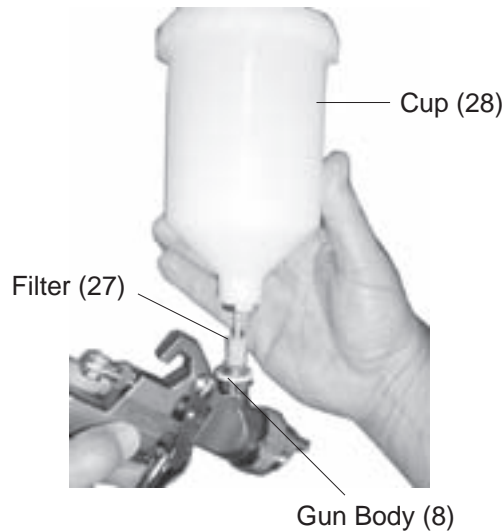

**PLEASE READ THE FOLLOWING CAREFULLY**

THE MANUFACTURER AND/OR DISTRIBUTOR HAS PROVIDED THE PARTS DIAGRAM IN THIS MANUAL AS A REFERENCE TOOL ONLY. NEITHER THE MANUFACTURER NOR DISTRIBUTOR MAKES ANY REPRESENTATION OR WARRANTY OF ANY KIND TO THE BUYER THAT HE OR SHE IS QUALIFIED TO MAKE ANY REPAIRS TO THE PRODUCT OR THAT HE OR SHE IS QUALIFIED TO REPLACE ANY PARTS OF THE PRODUCT. IN FACT, THE MANUFACTURER AND/OR DISTRIBUTOR EXPRESSLY STATES THAT ALL REPAIRS AND PARTS REPLACEMENTS SHOULD BE UNDERTAKEN BY CERTIFIED AND LICENSED TECHNICIANS AND NOT BY THE BUYER. THE BUYER ASSUMES ALL RISK AND LIABILITY ARISING OUT OF HIS OR HER REPAIRS TO THE ORIGINAL PRODUCT OR REPLACEMENT PARTS THERETO, OR ARISING OUT OF HIS OR HER INSTALLATION OF REPLACEMENT PARTS THERETO.

**NOTE:** Some parts are listed and shown for illustration purposes only and are not available individually as replacement parts.



# Assembly Drawing

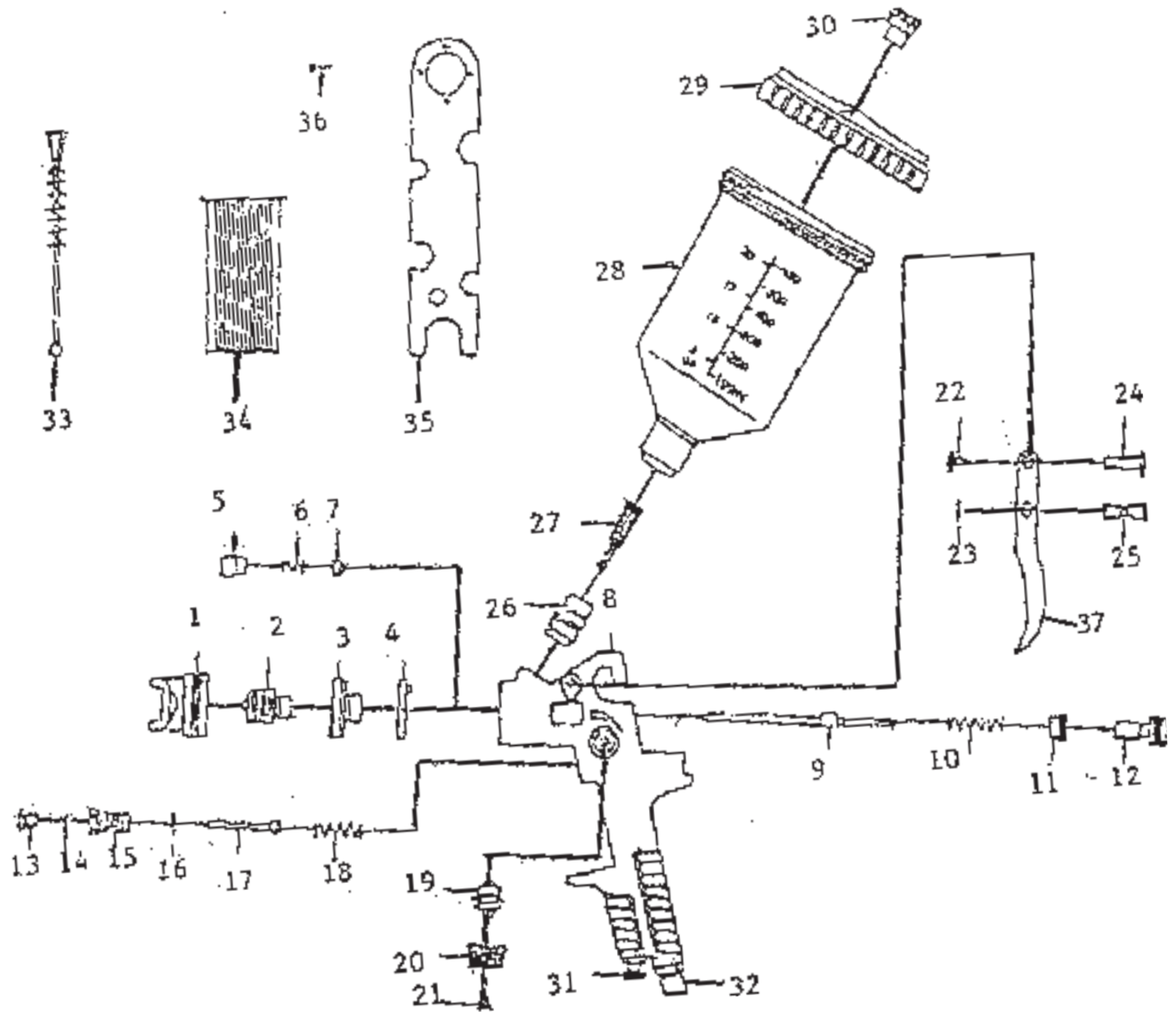

## 90 Day Warranty

Harbor Freight Tools Co. makes every effort to assure that its products meet high quality and durability standards, and warrants to the original purchaser that this product is free from defects in materials and workmanship for the period of 90 days from the date of purchase. This warranty does not apply to damage due directly or indirectly, to misuse, abuse, negligence or accidents, repairs or alterations outside our facilities, criminal activity, improper installation, normal wear and tear, or to lack of maintenance. We shall in no event be liable for death, injuries to persons or property, or for incidental, contingent, special or consequential damages arising from the use of our product. Some states do not allow the exclusion or limitation of incidental or consequential damages, so the above limitation of exclusion may not apply to you. THIS WARRANTY IS EXPRESSLY IN LIEU OF ALL OTHER WARRANTIES, EXPRESS OR IMPLIED, INCLUDING THE WARRANTIES OF MERCHANTABILITY AND FITNESS.

To take advantage of this warranty, the product or part must be returned to us with transportation charges prepaid. Proof of purchase date and an explanation of the complaint must accompany the merchandise. If our inspection verifies the defect, we will either repair or replace the product at our election or we may elect to refund the purchase price if we cannot readily and quickly provide you with a replacement. We will return repaired products at our expense, but if we determine there is no defect, or that the defect resulted from causes not within the scope of our warranty, then you must bear the cost of returning the product.

This warranty gives you specific legal rights and you may also have other rights which vary from state to state.

**3491 Mission Oaks Blvd. • PO Box 6009 • Camarillo, CA 93011 • (800) 444-3353**

## Free Manuals Download Website

<http://myh66.com>

<http://usermanuals.us>

<http://www.somanuals.com>

<http://www.4manuals.cc>

<http://www.manual-lib.com>

<http://www.404manual.com>

<http://www.luxmanual.com>

<http://aubethermostatmanual.com>

Golf course search by state

<http://golfingnear.com>

Email search by domain

<http://emailbydomain.com>

Auto manuals search

<http://auto.somanuals.com>

TV manuals search

<http://tv.somanuals.com>