



# 6.5 HP PRESSURE WASHER

**Model 67596**

## SET UP, OPERATING, AND SERVICING INSTRUCTIONS



<b>⚠ DANGER</b>	
Using an engine indoors <b>CAN KILL YOU IN MINUTES.</b> Engine exhaust contains carbon monoxide. This is a poison you cannot see or smell.	
<b>NEVER</b> use inside a home or garage, <b>EVEN IF</b> doors and windows are open.	
	Only use <b>OUTSIDE</b> and far away from windows, doors, and vents.

Visit our website at: <http://www.harborfreight.com>



**Read this material before using this product.  
Failure to do so can result in serious injury.  
SAVE THIS MANUAL.**

Copyright© 2009 by Harbor Freight Tools®. All rights reserved. No portion of this manual or any artwork contained herein may be reproduced in any shape or form without the express written consent of Harbor Freight Tools. Diagrams within this manual may not be drawn proportionally. Due to continuing improvements, actual product may differ slightly from the product described herein. Tools required for assembly and service may not be included.

**For technical questions or replacement parts, please call 1-800-444-3353.**

---

## CONTENTS

---

<b>IMPORTANT SAFETY INFORMATION .....</b>	<b>3</b>	<b>PARTS LIST &amp; DIAGRAM E - CRANKSHAFT/PISTON .....</b>	<b>32</b>
<b>SET UP PRECAUTIONS .....</b>	<b>3</b>	<b>PARTS LIST &amp; DIAGRAM F - GAS DISTRIBUTION ADJUSTMENT SYSTEM.....</b>	<b>33</b>
<b>OPERATING PRECAUTIONS.....</b>	<b>4</b>	<b>PARTS LIST &amp; DIAGRAM G - STARTER SUBASSEMBLY.....</b>	<b>34</b>
<b>SERVICE PRECAUTIONS .....</b>	<b>6</b>	<b>PARTS LIST &amp; DIAGRAM H - DIVERSION ASSEMBLY .....</b>	<b>35</b>
<b>BASIC SPECIFICATIONS .....</b>	<b>8</b>	<b>PARTS LIST &amp; DIAGRAM J - CARBURETOR.....</b>	<b>36</b>
<b>UNPACKING .....</b>	<b>8</b>	<b>PARTS LIST &amp; DIAGRAM K - FLYWHEEL/COIL ASSEMBLY .....</b>	<b>37</b>
<b>SET UP INSTRUCTIONS.....</b>	<b>8</b>	<b>PARTS LIST &amp; DIAGRAM M - CONTROL SYSTEM .....</b>	<b>38</b>
<b>ASSEMBLY.....</b>	<b>9</b>	<b>PARTS LIST &amp; DIAGRAM N - AIR CLEANER .....</b>	<b>39</b>
<b>ENGINE DIAGRAM.....</b>	<b>11</b>	<b>PARTS LIST &amp; DIAGRAM P - MUFFLER .....</b>	<b>40</b>
<b>OPERATING INSTRUCTIONS ....</b>	<b>12</b>	<b>PARTS LIST &amp; DIAGRAM R - FUEL TANK .....</b>	<b>41</b>
<b>STARTING THE ENGINE .....</b>	<b>12</b>	<b>PARTS LIST &amp; DIAGRAM S - CARBON CANISTER .....</b>	<b>42</b>
<b>EQUIPMENT OPERATION.....</b>	<b>15</b>	<b>LIMITED 1 YEAR / 90 DAY WARRANTY .....</b>	<b>43</b>
<b>TECHNICAL SPECIFICATIONS ..</b>	<b>17</b>	<b>EMISSION CONTROL SYSTEM WARRANTY.....</b>	<b>43</b>
<b>SERVICING.....</b>	<b>17</b>		
<b>MAINTENANCE PROCEDURES .....</b>	<b>17</b>		
<b>CLEANING, MAINTENANCE, AND LUBRICATION SCHEDULE .....</b>	<b>19</b>		
<b>STORAGE .....</b>	<b>20</b>		
<b>TROUBLESHOOTING.....</b>	<b>21</b>		
<b>PARTS LISTS AND DIAGRAMS .</b>	<b>25</b>		
<b>GENERAL PARTS LIST.....</b>	<b>25</b>		
<b>GENERAL ASSEMBLY DIAGRAM ..</b>	<b>26</b>		
<b>PARTS LIST A - PUMP.....</b>	<b>27</b>		
<b>ASSEMBLY DIAGRAM A - PUMP ...</b>	<b>28</b>		
<b>PARTS LIST &amp; DIAGRAM B - CYLINDER HEAD.....</b>	<b>29</b>		
<b>PARTS LIST &amp; DIAGRAM C - CRANKCASE .....</b>	<b>30</b>		
<b>PARTS LIST &amp; DIAGRAM D - CRANKCASE COVER.....</b>	<b>31</b>		

---

## SAVE THIS MANUAL

---

Keep this manual for the safety warnings and precautions, assembly, operating, inspection, maintenance and cleaning procedures. Write the product's serial number in the back of the manual near the assembly diagram (or month and year of purchase if product has no number). Keep this manual and the receipt in a safe and dry place for future reference.

---

## IMPORTANT SAFETY INFORMATION

---

In this manual, on the labeling, and all other information provided with this product:



This is the safety alert symbol. It is used to alert you to potential personal injury hazards. Obey all safety messages that follow this symbol to avoid possible injury or death.

### **DANGER**

**DANGER** indicates a hazardous situation which, if not avoided, will result in death or serious injury.

### **WARNING**

**WARNING** indicates a hazardous situation which, if not avoided, could result in death or serious injury.

### **CAUTION**

**CAUTION**, used with the safety alert symbol, indicates a hazardous situation which, if not avoided, could result in minor or moderate injury.

### **NOTICE**

**NOTICE** is used to address practices not related to personal injury.

### **CAUTION**

**CAUTION**, without the safety alert symbol, is used to address practices not related to personal injury.



**WARNING! Read all instructions. Failure to follow all instructions listed below may result in fire, serious injury and/or DEATH.**

The warnings and precautions discussed in this manual cannot cover all possible conditions and situations that may occur. It must be understood by the operator that common sense and caution are factors which cannot be built into this product, but must be supplied by the operator.

### **SAVE THESE INSTRUCTIONS**

### **SET UP PRECAUTIONS**

1. Gasoline fuel and fumes are flammable, and potentially explosive. Use proper fuel storage and handling procedures. Do not store fuel or other flammable materials nearby.
2. Have multiple ABC class fire extinguishers nearby.
3. This equipment has a spark arresting muffler included. A spark arresting muffler is required by law in California, on some US Forest Service land, and possibly in other areas or situations.
4. Set up and use only on a flat, level, well-ventilated surface.

5. The work area should have adequate drainage to reduce the possibility of a fall due to slippery surfaces.
6. Wear ANSI-approved safety goggles, heavy-duty work gloves, and dust mask/respirator during set up and use.
7. Use only oil and fuel recommended in the "Specifications" section of this manual.
8. Only use cold Water or pressure washer detergent in this tool. Do not use caustic materials, solvents, flammable materials, or detergents not designed for pressure washers. Use of any such material can cause injury, or damage this tool or personal property.
9. Do not dry run this product. Dry running will cause serious damage to the seals. Make sure the water supply used for the Pressure Washer is not dirty or sandy.
10. Prior to starting the Pressure Washer in cold weather, check all of the parts of the unit to make sure ice has not formed. Do not store the unit anywhere that the temperature will fall below 32° F (0° C).



NEVER use inside a home or garage, EVEN IF doors and windows are open.



Only use OUTSIDE and far away from windows, doors, and vents.

2. Keep children away from the equipment, especially while it is operating.
3. Do not leave the equipment unattended when it is running. Turn off the equipment (and remove safety keys, if available) before leaving the work area.
4. Wear ANSI-approved safety goggles and hearing protection during use.
5. People with pacemakers should consult their physician(s) before use. Electromagnetic fields in close proximity to a heart pacemaker could cause pacemaker interference or pacemaker failure. Caution is necessary when near the engine's magneto or recoil starter.
6. Use only accessories that are recommended by Harbor Freight Tools for your model. Accessories that may be suitable for one piece of equipment may become hazardous when used on another piece of equipment.

## OPERATING PRECAUTIONS

1.  **CARBON MONOXIDE HAZARD**  
**Using an engine indoors CAN KILL YOU IN MINUTES.**

Engine exhaust contains carbon monoxide. This is a poison you cannot see or smell.

7. Do not operate in explosive atmospheres, such as in the presence of flammable liquids, gases, or dust. Gasoline-powered engines may ignite the dust or fumes.
8. Stay alert, watch what you are doing and use common sense when operating a piece of equipment. Do not use a piece of equipment while tired or under the influence of drugs, alcohol or medication.
9. Do not overreach. Keep proper footing and balance at all times. This enables better control of the equipment in unexpected situations.
10. Do not carry the spray handle with your finger on the trigger, whether engine is operating or not.
11. Use this equipment with both hands only. Using equipment with only one hand can easily result in loss of control.
12. Dress properly. Do not wear loose clothing or jewelry. Keep hair, clothing and gloves away from moving parts. Loose clothes, jewelry or long hair can be caught in moving parts.
13. Parts of the Pressure Washer, especially exhaust system components, get very hot during use. Stay clear of hot parts.
14. Do not cover the engine or equipment during operation.
15. Keep the equipment, engine, and surrounding area clean at all times.
16. Use the equipment, accessories, etc., in accordance with these instructions and in the manner intended for the particular type of equipment, taking into account the working conditions and the work to be performed. Use of the equipment for operations different from those intended could result in a hazardous situation.
17. Do not operate the equipment with known leaks in the engine's fuel system.
18. This product contains or, when used, produces a chemical known to the State of California to cause cancer and birth defects or other reproductive harm. (California Health & Safety Code § 25249.5, *et seq.*)
19. WARNING: The brass components of this product contain lead, a chemical known to the State of California to cause birth defects (or other reproductive harm). (California Health & Safety code § 25249.5, *et seq.*)
20. When spills of fuel or oil occur, they must be cleaned up immediately. Dispose of fluids and cleaning materials as per any local, state, or federal codes and regulations. Store oil rags in a bottom-ventilated, covered, metal container.
21. Keep hands and feet away from moving parts. Do not reach over or across equipment while operating.
22. Before use, check for misalignment or binding of moving parts, breakage of parts, and any other condition that may affect the equipment's operation. **If damaged, have the equipment serviced before use.** Many accidents are caused by poorly maintained equipment.

23. Use the correct equipment for the application. Do not modify the equipment and do not use the equipment for a purpose for which it is not intended.
24. The high pressure water flow can damage the work surface if not used properly. Always test the spray in an open area first.
25. When dispensing detergent, apply the detergent to the cleaning area at low pressure only. Detergent dispensing only works when the spray wand is in the low-pressure position.
26.  Injection Hazard. The high pressure water jet produced by this tool can cut skin or cause injury to hands or eyes. Do not allow spray to strike you and do not spray toward people or animals. Do not spray the tool itself or any electrical source.
27. This Pressure Washer is intended for outdoor residential use only.
28. **In case of an emergency during use, immediately release the trigger on the spray handle, turn the engine off and then shut off gas supply to the engine. Do not set the spray handle down without turning off the engine.**

**Vibration Hazard:**

This tool vibrates during use. Repeated or long-term exposure to vibration may cause temporary or permanent physical injury, particularly to the hands, arms and shoulders. To reduce the risk of vibration-related injury:

1. Anyone using vibrating tools regularly or for an extended period should first be examined by a doctor and then have regular medical check-ups to ensure medical problems are not being caused or worsened from use. Pregnant women or people who have impaired blood circulation to the hand, past hand injuries, nervous system disorders, diabetes, or Raynaud's Disease should not use this tool. If you feel any medical or physical symptoms related to vibration (such as tingling, numbness, and white or blue fingers), seek medical advice as soon as possible.
2. Do not smoke during use. Nicotine reduces the blood supply to the hands and fingers, increasing the risk of vibration-related injury.
3. Wear suitable gloves to reduce the vibration effects on the user.
4. Use tools with the lowest vibration when there is a choice between different processes.
5. Include vibration-free periods each day of work.
6. Grip tool as lightly as possible (while still keeping safe control of it). Let the tool do the work.
7. To reduce vibration, maintain the tool as explained in this manual. If any abnormal vibration occurs, stop use immediately.

**SERVICE PRECAUTIONS**

1. **Before service, maintenance, or cleaning:**
  - a. **Turn the engine switch to its "OFF" position.**

- b. **Allow the engine to completely cool.**
  - c. **Then, remove the spark plug wire(s) from the spark plug(s).**
2. Keep all safety guards in place and in proper working order. Safety guards include muffler, air cleaner, mechanical guards, and heat shields, among other guards.
  3. **Do not alter or adjust any part of the equipment or its engine that is sealed by the manufacturer or distributor. Only a qualified service technician may adjust parts that may increase or decrease governed engine speed.**
  4. Wear ANSI-approved safety goggles, heavy-duty work gloves, and dust mask/respirator during use and service.
  5. Keep the high pressure hose connected to the pressure washer and spray Gun while the system is pressurized. Disconnecting the pressure hose while the unit is pressurized is dangerous, and may cause injury.
  6. Do not allow the high pressure hose to come in contact with any hot part of the unit. The hose might be damaged, possibly causing it to burst or leak under high pressure.
  7. Maintain labels and nameplates on the equipment. These carry important information. If unreadable or missing, contact Harbor Freight Tools for a replacement.
  8. If water is leaking out of the Pressure Washer immediately turn off the unit. Unplug the Pressure Washer, and discharge all pressure before tightening fittings or having repair work done by a qualified technician.
  9. When the engine is running, do not allow the Pressure Washer to remain idle for more than two minutes. If allowed to remain idle, the water in the unit will heat up, possibly causing damage to the Pressure Washer.
  10. Have the equipment serviced by a qualified repair person using only identical replacement parts. This will ensure that the safety of the equipment is maintained. Do not attempt any service or maintenance procedures not explained in this manual or any procedures that you are uncertain about your ability to perform safely or correctly.
  11. Store equipment out of the reach of children.
  12. Follow scheduled engine and equipment maintenance.

**Refueling:**

1. Do not smoke, or allow sparks, flames, or other sources of ignition around the equipment, especially when refuelling.
2. Do not refill the fuel tank while the engine is running or hot.
3. Do not fill fuel tank to the top. Leave a little room for the fuel to expand as needed.
4. Refuel in a well-ventilated area only.



**SAVE THESE INSTRUCTIONS.**

## BASIC SPECIFICATIONS

Fuel	Type	89+ octane unleaded gasoline
	Capacity	0.95 Gallons
Engine Oil	Type (SAE)	10W-30 above 32° F 5W-30 at 32° F or below
	Capacity	0.63 Quarts
Pump Oil		3.75 fl-oz SAE 10W-30 Non-detergent
Engine Speed		3,600 RPM
Water Flow		3 GPM Maximum
Maximum Pressure		2,500 PSI

**Note:** Additional specifications found in the TECHNICAL ENGINE SPECIFICATIONS chart in this manual.

The emission control system for this Generator's Engine is warranted for standards set by the U.S. Environmental Protection Agency and by the California Air Resources Board (also known as CARB). For warranty information, refer to the last pages of this manual.

At high altitudes, the engine's carburetor, governor (if so equipped), and any other parts that control the fuel-air ratio will need to be adjusted by a qualified mechanic to allow efficient high-altitude use and to prevent damage to the engine and any other devices used with this product.

## UNPACKING

When unpacking, make sure that the item is intact and undamaged. If any parts are missing or broken, please call Harbor Freight Tools at 1-800-444-3353 as soon as possible.

## SET UP INSTRUCTIONS



Read the **ENTIRE IMPORTANT SAFETY INFORMATION** section at the beginning of this manual including all text under subheadings therein before set up or use of this product.

### **WARNING**

**Risk of accidental starting; resulting in serious personal injury. Turn the Power Switch of the equipment to its "OFF" position, wait for the engine to cool, and unplug the spark plug wire(s) before assembling or making any adjustments to the equipment.**

**Note:** For additional information regarding the parts listed in the following pages, refer to the Assembly Diagram near the end of this manual.



## Assembly

1. This equipment has a spark arresting muffler included. A spark arresting muffler is required by law in California, on some US Forest Service land, and possibly in other areas or situations.

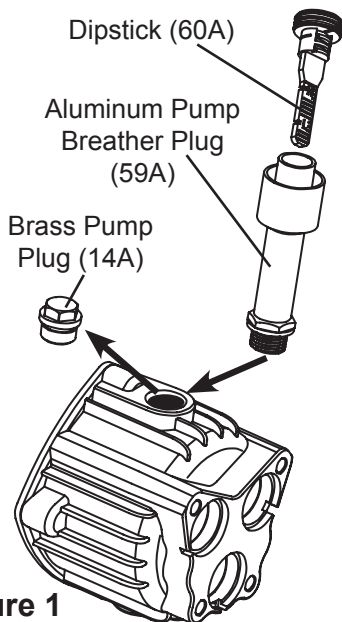

**Figure 1**

2. Replace the Brass Pump Plug (14A) with the aluminum Pump Breather Plug (59A) and Dipstick (60A) before first use. The Pump Breather Plug must be used whenever the pressure washer is used. The Brass Pump Plug (without the breather hole) should be used for transporting only.
3. Attach the Handle (14) onto the Frame (17) with the Handle Bolts (15) and Nuts (16).

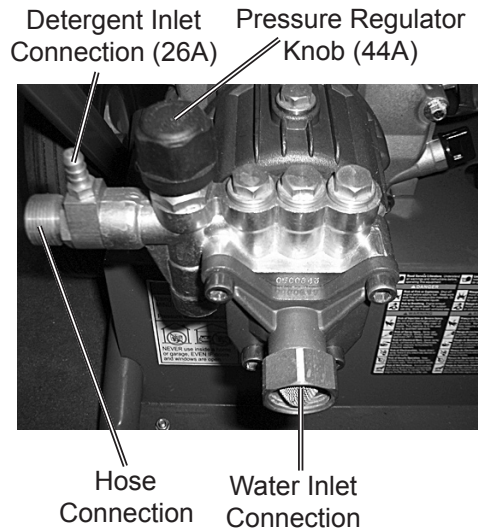

**Figure 2**

4. Attach the Hose (18) to the Hose Connection on the unit. (See Figure 2.)
5. Pull the Collar at the end of the hose back and attach the Gun (19) to the hose.
6. Screw the Wand (20) onto the Gun and secure with the grommet.
7. Choose the right Nozzle (5) for the job. Pull back the quick connect collar and push the Nozzle onto the end of the Wand. Make sure the quick connect collar locks the Nozzle in place.
  - **Black Nozzle - Low Pressure**  
This Nozzle is used with pressure washer detergent.
  - **White Nozzle - Wide Spray**  
This Nozzle can be used to clean very large areas.
  - **Green Nozzle - Medium Spray**  
This Nozzle can be used to clean larger areas.

- **Yellow Nozzle - Narrow Spray**  
This Nozzle is used to clean small areas.
  - **Red Nozzle - Pencil Spray**  
This Nozzle should only be used on hard surfaces such as concrete or metal. This Nozzle can damage wood.
8. Connect the water supply to the Water Inlet Connection. The water source must be able to provide a minimum of five gallons of clean, cold water per minute at 20 PSI. Only use a 5/8" inner diameter (or larger) hose that is rated to meet this capacity.

**If using detergent:**

9. Read detergent directions. Connect one end of the Detergent Inlet Hose (8) to the Detergent Inlet Connection, and the other end into the container holding the detergent. Only use detergents specified for use with Pressure Washers. The Pressure Washer will draw one gallon of detergent for every seven gallons of water. Only use the Black (low pressure) Nozzle when spraying detergents.

---

## ENGINE DIAGRAM

---

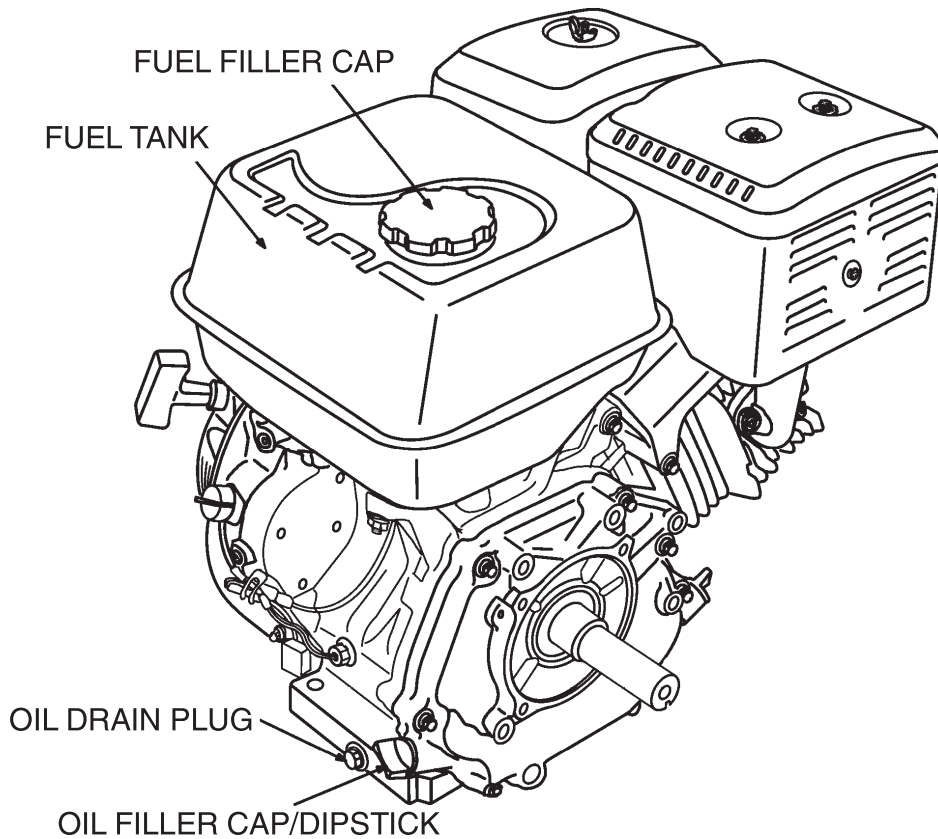
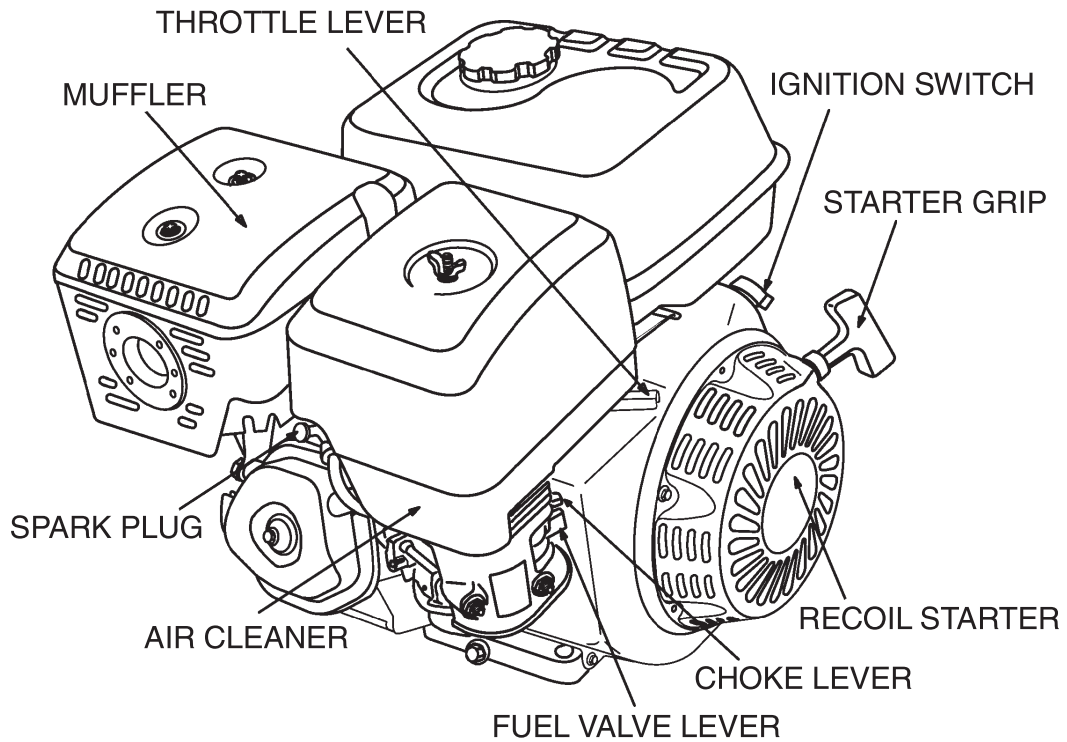

## OPERATING INSTRUCTIONS



Read the **ENTIRE IMPORTANT SAFETY INFORMATION** section at the beginning of this manual including all text under subheadings therein before set up or use of this product.

### Starting the Engine



Inspect engine and equipment looking for damaged, loose, and missing parts before set up and starting. If any problems are found, do not use equipment until fixed properly.

### Checking Engine Oil Level

**CAUTION!** Your Warranty is VOID if the engine's crankcase is not properly filled with oil before each use. Before each use, check the oil level. Do not run the engine with low or no engine oil. Running the engine with no or low engine oil WILL permanently damage the engine.

1. Turn off engine and allow it to cool.
2. Clean the Oil Filler Cap and the area around it. Remove the Oil Filler Cap.

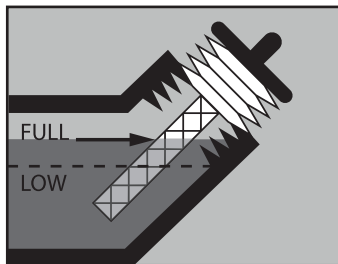

Figure 3

3. Remove dipstick and wipe away the oil with dry cloth. Reinsert the dipstick into the oil filler neck, but do not screw in, then remove it to check the oil level. The oil level should reach

the upper limit (H) mark on the dipstick (bottom edge of the oil fill hole). Low oil level can trigger the low oil sensor to shutdown the engine and prevent restart (See Figure 3 for correct oil level).

4. If the oil level is low, add the appropriate type of oil until the oil level is at the bottom lip of the oil fill hole.

#### **Oil type:**

32° F or above = SAE 10W-30

Below 32° F = SAE 5W-30.

5. Replace the Oil Filler Cap.

**CAUTION!** Do not run the engine with too little or too much oil. The engine will be permanently damaged.

### Checking Pump Oil Level

1. The Oil pump is filled with 3.75 fl-oz of SAE 10W-30 NON DETERGENT oil at the factory. Under normal conditions there is no reason to add any oil or change the oil.
2. Turn off engine, allow it to cool and disconnect the spark plug wire.
3. Twist the Dipstick on the Pump Breather Plug until the arrow on it lines up with the arrow on the Plug and remove the Dipstick.
4. Remove the Pump Breather Plug from the Pump.

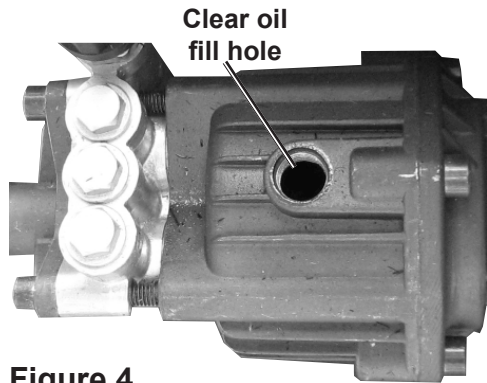

**Figure 4**

5. Look into the hole in the pump housing. If a metal wheel can be seen extending into the hole, SLOWLY pull the starter rope until the hole appears clear, as shown above.

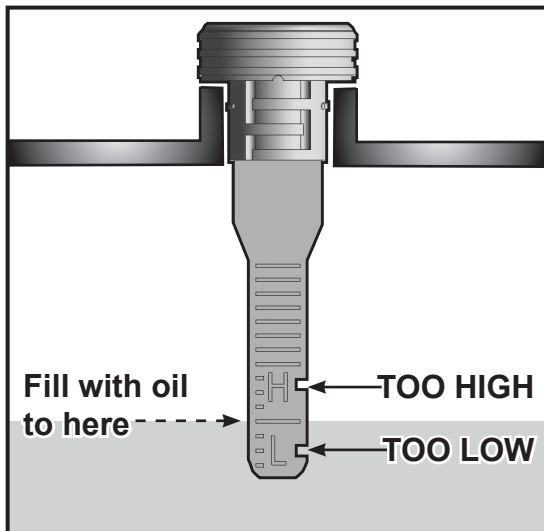

**Figure 5**

6. Wipe the Dipstick off with a clean, dry cloth. Insert the Dipstick into the pump housing and remove it. The oil level should be at least to the lower (L) notch on the dipstick, but not above the upper (H) notch. Add SAE 10W-30 NON-DETERGENT oil as needed.
7. Thread the Pump Breather Plug back into the pump.

8. Align the arrow on the Dipstick with the arrow on the Plug, insert it, and twist it to secure.
9. Reconnect the spark plug wire.

### Checking Fuel Level



**⚠️WARNING!** To prevent fire, shut the engine off and wait for it to cool before adding fuel. Do not smoke.

1. Clean the Fuel Filler Cap and the area around it.
2. To check the fuel level, unscrew and remove the Fuel Filler Cap.
3. Mix fuel stabilizer (not included) with 89 octane (or better) unleaded gasoline according to fuel stabilizer directions.
4. Fill the Fuel Tank to about 1 inch under the lip of the gasoline tank with the stabilized unleaded gasoline mixture.
5. Then replace the Fuel Filler Cap.

## Start Procedure



### **Before starting the engine:**

- a. **Follow the Set Up Instructions to prepare the equipment.**
  - b. **Inspect the equipment and engine. Make sure the pump has the Pump Breather Plug installed.**
  - c. **Replace the non-vented brass oil plug with the aluminum Pump Breather Plug.**
  - d. **Fill the engine with the proper amount and type of both fuel and oil.**
  - e. **Read the Equipment Operation section that follows.**
1. Point Nozzle in safe direction and squeeze trigger to release all pressure from the pump.
  2. Turn the fuel valve lever to its "OPEN" position.
  3. Turn the ignition switch to its ON or RUN position.
  4. Then, turn the engine choke lever to its "CHOKE" position for cold start. Set the choke lever in the "1/2 CHOKE" position when starting a warm engine.
  5. Close the throttle.
  6. Grasp the starter handle, and pull slowly until resistance is felt. While holding the handle, allow the starter rope to rewind slowly. Then, pull the starter handle with a rapid, full arm stroke. Once again while holding the handle, allow the rope to rewind slowly. Repeat as necessary, until the engine starts.

7. After the engine starts and warms up, slowly move the choke lever to its "RUN" position.
8. **IMPORTANT:** Allow the engine to run at no load (low pressure) for five minutes after each start-up so that the engine can stabilize.
9. Move the throttle up to operating speed. Operating speed is maximum speed (fast or rabbit), except during operational break-in period.

### Break-in Period

1. Breaking-in the engine will help to ensure proper equipment and engine operation.
2. The operational break-in period will last about 3 hours of use. During this period:
  - Do not apply a heavy load to the equipment.
  - Do not operate the engine at its maximum speed.
3. The maintenance break-in period will last about 20 hours of use. After this period:
  - Change the engine oil.Under normal operating conditions subsequent maintenance follows the schedule in the MAINTENANCE AND SERVICING section.

## Equipment Operation

**⚠️ WARNING** Do not direct spray from the pressure washer at a person or an animal. The water stream could cause serious injury.

**CAUTION** Use the pressure washer only on surfaces able to withstand the force of the spray.

1. Replace the non-vented brass oil plug with the aluminum Pump Breather Plug before first use. The Pump Breather Plug must be used whenever the pressure washer is used. The brass oil plug (without the breather hole) should be used for transporting only.
2. Choose the Nozzle that best meets the needs of the job. Only use the Nozzles on surfaces capable of withstanding the force of the spray. **Only use the Black Nozzle when using pressure washer detergent. The power of the other Nozzles will propel mist back at the operator and can imbed detergent into the surface.**
3. Pull back the quick connect collar and push the Nozzle onto the end of the Wand. Make sure the quick connect collar locks the Nozzle in place.
4. Turn the water supply on and hold down the Trigger to start the stream. Be aware that when it is first started, the gun will kick.
5. It is best to start at a low pressure setting, and adjust the pressure upwards. Test spray the edge of the surface to be cleaned first to make sure that the stream is not too strong for the surface. If the stream damages the surface turn the Pressure Regulator Knob counterclockwise to reduce the pressure. Moving further away from the surface being cleaned will also reduce the pressure being applied to the surface. If the stream is still too strong. Turn the engine off, turn the water supply off, discharge the excess pressure from the gun by squeezing the Trigger, and change to a lower pressure Nozzle.
6. To increase the pressure, turn the Pressure Regulator Knob clockwise.

7. Hold the Wand at about a 45° angle when cleaning; spraying the surface directly could embed dirt into the surface (especially with the high pressure Nozzles). Spray at a distance of about three to five feet.
  - Clean vertical and sloped surfaces from the top down.
  - When cleaning horizontal surfaces, occasionally use the stream to clear the area of excess water.
- CAUTION Do not allow the Pressure Washer to idle, without the Trigger held down, for more than two minutes. The water will heat up and damage the Pressure Washer. RISK OF BURNS! The pump will also expel very hot water if allowed to idle too long.**
8. Hold the Trigger down and move the Wand back and forth slowly and steadily to pressure wash the surface. Take special care when spraying surfaces made of two different materials (brick and mortar, for example), to not damage the softer of the two materials during pressure washing.
9. If the surface is streaked or uneven at the end of a job, switch to a Nozzle that has a wider spray pattern to blend the affected area.
10. When finished; release the Trigger on the spray handle, turn the engine power switch “OFF”, turn the water supply off and then shut off gas supply to the engine.
11. Squeeze the Trigger to release excess pressure.
12. If Pressure Washer detergent has been used for the job, run clean water through the system to eliminate detergent residue.
13. To prevent accidents, turn off the engine and after the engine has cooled, disconnect its spark plug wire after use. Drain all water out of the unit. Clean external parts with clean cloth, then store the equipment out of children’s reach according to the Storage instructions in this manual.



## TECHNICAL SPECIFICATIONS

Engine Type		Single Cylinder 4 stroke OHV
Bore x Stroke		68mm x 54mm
Displacement		196cc
Compression Ratio		8.5:1
Rotation viewed from PTO (power takeoff - the output shaft)		Counterclockwise
Fuel	Type	89+ octane unleaded gasoline
	Capacity	0.95 Gallons
Engine Oil	Type SAE	10W30 above 32° F 5W30 at 32° F or below
	Capacity	0.63 Quarts
Spark Plug	Type	F7RTC or NGK F7TC
	Gap	0.028 - 0.031"
Valve Clearance	Intake	0.15 ± 0.02 mm
	Exhaust	0.20 ± 0.02 mm
Speed	Idle	1,400 ± 150 RPM
	Maximum	3,600 RPM

## SERVICING

### **WARNING**

**Risk of serious personal injury from accidental starting. Turn the Power Switch of the equipment to its "OFF" position, wait for the engine to cool, and unplug the spark plug wire(s) before performing any inspection, maintenance, or cleaning procedures.**

**Damaged equipment can fail, causing serious personal injury. Do not use damaged equipment. If abnormal noise, vibration, or excess smoking occurs, have the problem corrected before further use.**

### Maintenance Procedures



**Many maintenance procedures, including any not detailed in this manual, will need to be performed by a qualified technician for safety. If you have any doubts about your ability to safely service the equipment or engine, have a qualified technician service the equipment instead.**

### Engine Oil Change

**CAUTION!** Oil is very hot during operation and can cause burns. Wait for engine to cool before changing oil.

1. Place a drain pan (not included) underneath the crankcase's Drain Plug (61A).
2. Remove the Drain Plug and, if possible, tilt the crankcase slightly to help drain the oil out. Recycle used oil.
3. Replace the Drain Plug and tighten it.
4. Refill the oil to the proper level following the instructions under the Starting the Engine section.

### **Air Filter Element Maintenance**

1. The air cleaner cover is held in place by a wing nut or clamps. Remove it.
2. Remove the air filter element.
3. **Cleaning:**
  - a. For “paper” filter elements:  
To prevent injury from dust and debris, wear ANSI-approved safety goggles, NIOSH-approved dust mask/respirator, and heavy-duty work gloves. In a well-ventilated area away from bystanders, use pressurized air to blow dust out of the air filter.  
If this does not get the filter reasonably clean, replace it.
  - b. For foam filter elements:  
Wash the element in warm water and mild detergent several times. Rinse. Squeeze out excess water and allow it to dry completely. Soak the filter in lightweight oil briefly, then squeeze out the excess oil.
4. Install the new filter or the cleaned filter. Secure the Air Cleaner Cover before use.

### **Spark Plug Maintenance**

1. Disconnect spark plug wire from end of plug. Clean out debris from around spark plug.
2. Using a spark plug wrench, remove the spark plug.
3. Inspect the spark plug:  
If the electrode is oily, clean it using a clean, dry rag.  
If the electrode has deposits on it, polish it using emery paper.  
If the white insulator is cracked or chipped, the spark plug needs to be replaced.
4. When installing a new spark plug, adjust the plug’s gap to the specification on the Technical specification chart. Do not pry against the electrode, the spark plug can be damaged.
5. Install the new spark plug or the cleaned spark plug into the engine.  
Gasket-style: Finger-tighten until the gasket contacts the cylinder head, then about 1/2-2/3 turn more.  
Non-gasket-style: Finger-tighten until the plug contacts the head, then about 1/16 turn more.
6. Apply dielectric spark plug boot protector (not included) to the end of the spark plug and reattach the wire securely.

## Fuel Filter Replacement (if equipped)



**⚠WARNING! RISK OF FIRE OR EXPLOSION.** Replace the fuel filter in a well-ventilated area away from ignition sources. Do not smoke.

1. Wait for engine to cool completely before proceeding.
2. Wear protective gear including, ANSI-approved safety goggles, NIOSH-approved dust mask/respirator, and nitrile gloves.
3. Close fuel valve leading from gas tank completely.
4. Take note of the fuel filter's orientation.
5. Place a suitable container under the fuel filter.
6. Disconnect the fuel lines leading to and from the fuel filter and allow fuel to drain onto the container.
7. Install new fuel filter in the same orientation. Make sure to properly secure both fuel lines.
8. Clean up and properly dispose of all fuel.
9. Wait for at least one hour before use to allow all residual fuel vapors to dissipate. **To prevent FIRE, do not start the engine while the smell of fuel hangs in the air.** Remember to open the fuel valve before restarting the engine. It may take a little longer than usual to start the engine because the fuel needs to refill the fuel line and new filter.

## Cleaning, Maintenance, and Lubrication Schedule

**Note:** This maintenance schedule is intended solely as a general guide. If performance decreases or if equipment operates unusually, check systems immediately. The maintenance needs of each piece of equipment will differ depending on factors such as duty cycle, temperature, air quality, fuel quality, and other factors.

**Note:** These procedures are in addition to the regular checks and maintenance explained as part of the regular operation of the engine and equipment.

### After 20 Operation Hour Break-in Period:

- a. Change engine oil.

### After Every 25 Operation Hours:

- a. Clean/replace air filter element.
- b. Inspect/clean spark plug.
- c. Blow out water filters.

### After Every 50 Operation Hours:

- a. Change engine oil.
- b. Replace fuel filter (if equipped).

### After Every 100 Operation Hours:

- a. Replace spark plug.
- b. Replace air filter element.
- c. Change pump oil.

**Note:** All maintenance procedures scheduled for 25, 50, and 100 operation hours should be performed at least yearly.

### **After Every 300 Operation Hours:**

- a. Clean fuel tank and carburetor.
- b. Clean carbon build-up from combustion chamber.

### **Storage**

1. Wait for engine to cool, then clean engine with clean cloth.
2. When the equipment is to remain idle for longer than 20 days, prepare the engine for storage as follows:
  - a. Change engine oil and empty fuel tank.
  - b. Either leave fuel tank empty or refill fuel tank with fresh unleaded gasoline mixed with a fuel stabilizer intended for long term engine storage (not included). After filling, run engine for about 5-10 minutes to circulate the treated gasoline through the carburetor. Wait for engine to cool before proceeding.
  - c. Clean out area around spark plug. Remove spark plug and pour one tablespoon of engine oil into cylinder through spark plug hole.
  - d. Replace spark plug, but leave spark plug wire disconnected.
  - e. Pull recoil starter to distribute oil in cylinder. Stop after one or two revolutions when you feel the piston start the compression stroke (when you start to feel resistance).
  - f. Disconnect battery (if equipped).
3. Apply a thin coat of rust preventive oil to all metal parts.
4. Cover and store in a dry, well-ventilated area out of reach of children.
5. Before starting the engine after storage, keep in mind that untreated gasoline will deteriorate quickly. Drain the fuel tank and change to fresh fuel if untreated gasoline has been sitting for a month, if treated gasoline has been sitting beyond the fuel stabilizer's recommended time period, or if the engine does not start properly.

## Troubleshooting

Problem	Possible Causes	Probable Solutions
Engine will not start	<b>Starting instructions not followed completely.</b>	<b>Refer to starting instructions and follow them step-by-step.</b>
	<b>FUEL RELATED:</b> <ol style="list-style-type: none"> <li>1. No fuel in tank or fuel valve closed.</li> <li>2. Choke not in start position, especially with cold engine.</li> <li>3. Low quality or deteriorated, old gasoline.</li> <li>4. Dirty fuel passageways blocking fuel flow.</li> <li>5. Carburetor needle stuck. Fuel can be smelled in the air.</li> <li>6. Too much fuel in chamber. This can be caused by the carburetor needle sticking.</li> </ol>	<b>FUEL RELATED:</b> <ol style="list-style-type: none"> <li>1. Fill fuel tank and open fuel valve.</li> <li>2. Move choke to start position if engine is cold.</li> <li>3. Use only fresh 89+ octane unleaded gasoline.</li> <li>4. Clean out passageways using fuel additive. Heavy deposits may require further cleaning.</li> <li>5. <b>Gently</b> tap side of carburetor float chamber with screwdriver handle.</li> <li>6. Turn choke to run position. Remove spark plug and pull the start handle several times to air out the chamber. Reinstall spark plug and set choke to start position.</li> </ol>
	<b>IGNITION (SPARK) RELATED:</b> <ol style="list-style-type: none"> <li>1. Spark plug wire not connected securely.</li> <li>2. Spark plug electrode wet or dirty.</li> <li>3. Incorrect spark plug gap.</li> <li>4. Spark plug wire broken.</li> <li>5. Incorrect spark timing or faulty ignition system.</li> </ol>	<b>IGNITION (SPARK) RELATED:</b> <ol style="list-style-type: none"> <li>1. Connect spark plug wire properly.</li> <li>2. Clean spark plug.</li> <li>3. Correct spark plug gap.</li> <li>4. Replace spark plug wire.</li> <li>5. Have qualified technician diagnose/repair ignition system.</li> </ol>
<b>COMPRESSION RELATED:</b> <ol style="list-style-type: none"> <li>1. Cylinder not lubricated. Problem after long storage periods.</li> <li>2. Loose or broken spark plug. (Hissing noise will occur when trying to start.)</li> <li>3. Loose cylinder head or damaged head gasket. (Hissing noise will occur when trying to start.)</li> <li>4. Engine valves or tappets misadjusted or stuck.</li> </ol>	<b>COMPRESSION RELATED:</b> <ol style="list-style-type: none"> <li>1. Pour tablespoon of oil into spark plug hole. Crank engine a few times and try to start again.</li> <li>2. Tighten spark plug. If that does not work, replace spark plug. If problem persists, may have head gasket problem, see #3.</li> <li>3. Tighten head. If that does not remedy problem, replace head gasket.</li> <li>4. Adjust valve clearance. If that does not work, clean or replace valves/tappets.</li> </ol>	



**Follow all safety precautions whenever diagnosing or servicing the equipment or engine.**

## Troubleshooting

<b>Problem</b>	<b>Possible Causes</b>	<b>Probable Solutions</b>
Engine misfires	<ol style="list-style-type: none"> <li>1. Spark plug wire loose.</li> <li>2. Incorrect spark plug gap or damaged spark plug.</li> <li>3. Defective spark plug wire.</li> <li>4. Old or low quality gasoline.</li> <li>5. Incorrect compression.</li> </ol>	<ol style="list-style-type: none"> <li>1. Check wire connections.</li> <li>2. Re-gap or replace spark plug.</li> <li>3. Replace spark plug wire.</li> <li>4. Use only fresh 89+ octane unleaded gasoline.</li> <li>5. Diagnose and repair compression. (Use <b>Engine will not start: COMPRESSION RELATED</b> section.)</li> </ol>
Engine stops suddenly	<ol style="list-style-type: none"> <li>1. Low oil shutdown.</li> <li>2. Fuel tank empty or full of impure or low quality gasoline.</li> <li>3. Defective fuel tank cap creating vacuum, preventing proper fuel flow.</li> <li>4. Faulty magneto.</li> </ol>	<ol style="list-style-type: none"> <li>1. Fill engine oil to proper level. Check engine oil before EVERY use.</li> <li>2. Fill fuel tank with fresh 89+ octane unleaded gasoline.</li> <li>3. Test/replace fuel tank cap.</li> <li>4. Have qualified technician service magneto.</li> </ol>
Engine knocks	<ol style="list-style-type: none"> <li>1. Old or low quality gasoline.</li> <li>2. Engine overloaded.</li> <li>3. Incorrect spark timing, deposit buildup, worn engine, or other mechanical problems.</li> </ol>	<ol style="list-style-type: none"> <li>1. Fill fuel tank with fresh 89+ octane unleaded gasoline.</li> <li>2. Do not exceed equipment's load rating.</li> <li>3. Have qualified technician diagnose and service engine.</li> </ol>
Engine backfires	<ol style="list-style-type: none"> <li>1. Impure or low quality gasoline.</li> <li>2. Engine too cold.</li> <li>3. Intake valve stuck or overheated engine.</li> </ol>	<ol style="list-style-type: none"> <li>1. Fill fuel tank with fresh 89+ octane unleaded gasoline.</li> <li>2. Use cold weather fuel and oil additives to prevent backfiring.</li> <li>3. Have qualified technician diagnose and service engine.</li> </ol>
Does not produce high pressure	<ol style="list-style-type: none"> <li>1. Diameter of water supply hose too small</li> <li>2. Water supply is restricted.</li> <li>3. Not enough water supply.</li> </ol>	<ol style="list-style-type: none"> <li>1. Replace hose with a ¾ inch hose.</li> <li>2. Check water supply hose for kinks, leaks, or blockage.</li> <li>3. Open water faucet all the way.</li> </ol>

**Follow all safety precautions whenever diagnosing or servicing the equipment or engine.**

## Troubleshooting

Problem	Possible Causes	Probable Solutions
Output pressure varies	<ol style="list-style-type: none"> <li>1. Not enough water supply.</li> <li>2. Water inlet screen is clogged.</li> <li>3. Nozzle is clogged.</li> <li>4. Nozzle has mineral build up.</li> </ol>	<ol style="list-style-type: none"> <li>1. Check water supply hose for kinks, leaks, or blockage. Open faucet all the way.</li> <li>2. Remove inlet screen and rinse out.</li> <li>3. Remove Nozzle and clean.</li> <li>4. Remove Nozzle and clean with vinegar.</li> </ol>
No intake of chemicals.	<ol style="list-style-type: none"> <li>1. Chemical hose not properly inserted into unit.</li> <li>2. Tube cracked or split.</li> <li>3. Wrong Nozzle.</li> <li>4. Injector turned off.</li> <li>5. Injection tube strainer clogged.</li> <li>6. Nozzle blocked.</li> <li>7. Dried chemicals in injector.</li> </ol>	<ol style="list-style-type: none"> <li>1. Push firmly into injector. Replace tube.</li> <li>2. Switch to black Nozzle.</li> <li>3. Turn collar counterclockwise.</li> <li>4. Clean strainer.</li> <li>5. Clean Nozzle.</li> <li>6. Dissolve by running warm water through the injection tube.</li> <li>7. Run clean water through injector until clear.</li> </ol>

**Follow all safety precautions whenever diagnosing or servicing the equipment or engine.**

## **PLEASE READ THE FOLLOWING CAREFULLY**

THE MANUFACTURER AND/OR DISTRIBUTOR HAS PROVIDED THE PARTS LIST AND ASSEMBLY DIAGRAM IN THIS MANUAL AS A REFERENCE TOOL ONLY. NEITHER THE MANUFACTURER OR DISTRIBUTOR MAKES ANY REPRESENTATION OR WARRANTY OF ANY KIND TO THE BUYER THAT HE OR SHE IS QUALIFIED TO MAKE ANY REPAIRS TO THE PRODUCT, OR THAT HE OR SHE IS QUALIFIED TO REPLACE ANY PARTS OF THE PRODUCT. IN FACT, THE MANUFACTURER AND/OR DISTRIBUTOR EXPRESSLY STATES THAT ALL REPAIRS AND PARTS REPLACEMENTS SHOULD BE UNDERTAKEN BY CERTIFIED AND LICENSED TECHNICIANS, AND NOT BY THE BUYER. THE BUYER ASSUMES ALL RISK AND LIABILITY ARISING OUT OF HIS OR HER REPAIRS TO THE ORIGINAL PRODUCT OR REPLACEMENT PARTS THERETO, OR ARISING OUT OF HIS OR HER INSTALLATION OF REPLACEMENT PARTS THERETO.

**Record Product's Serial Number Here:** \_\_\_\_\_

**Note:** If product has no serial number, record month and year of purchase instead.

**Note:** Some parts are listed and shown for illustration purposes only, and are not available individually as replacement parts.



# PARTS LISTS AND DIAGRAMS

## General Parts List

Part	Description	Qty
1	Gun & Hose Holder	1
2	Washer	1
3	Nut	1
4	Grommet	5
5	Nozzle	5
6	Safety Warnings	1
7	Filter	1
8	Detergent Inlet Hose	1
9	Bolt	4
10	Lock Washer	4
11	Pump Assembly	1
12	Engine	1
13	Key	1
14	Handle	1
15	Handle Bolt	2
16	Nut	2
17	Frame	1
18	Hose	1
19	Gun	1
20	Wand	1

Part	Description	Qty
21	Pad	2
22	Washer	2
23	Nut	2
24	Engine Bolt	4
25	Lock Washer	2
26	Washer	2
27	Nut	2
28	Lock Washer	2
29	Axle Nut	2
30	Lock Washer	2
31	Washer	2
32	Axle	2
33	Clip	2
34	Wheel	2
35	Washer	2
36	Wheel Nut	2
37	Dipstick	1
38	Pump Fill Plug	1
39	O-ring	1
40	Shock Pad	4

# General Assembly Diagram

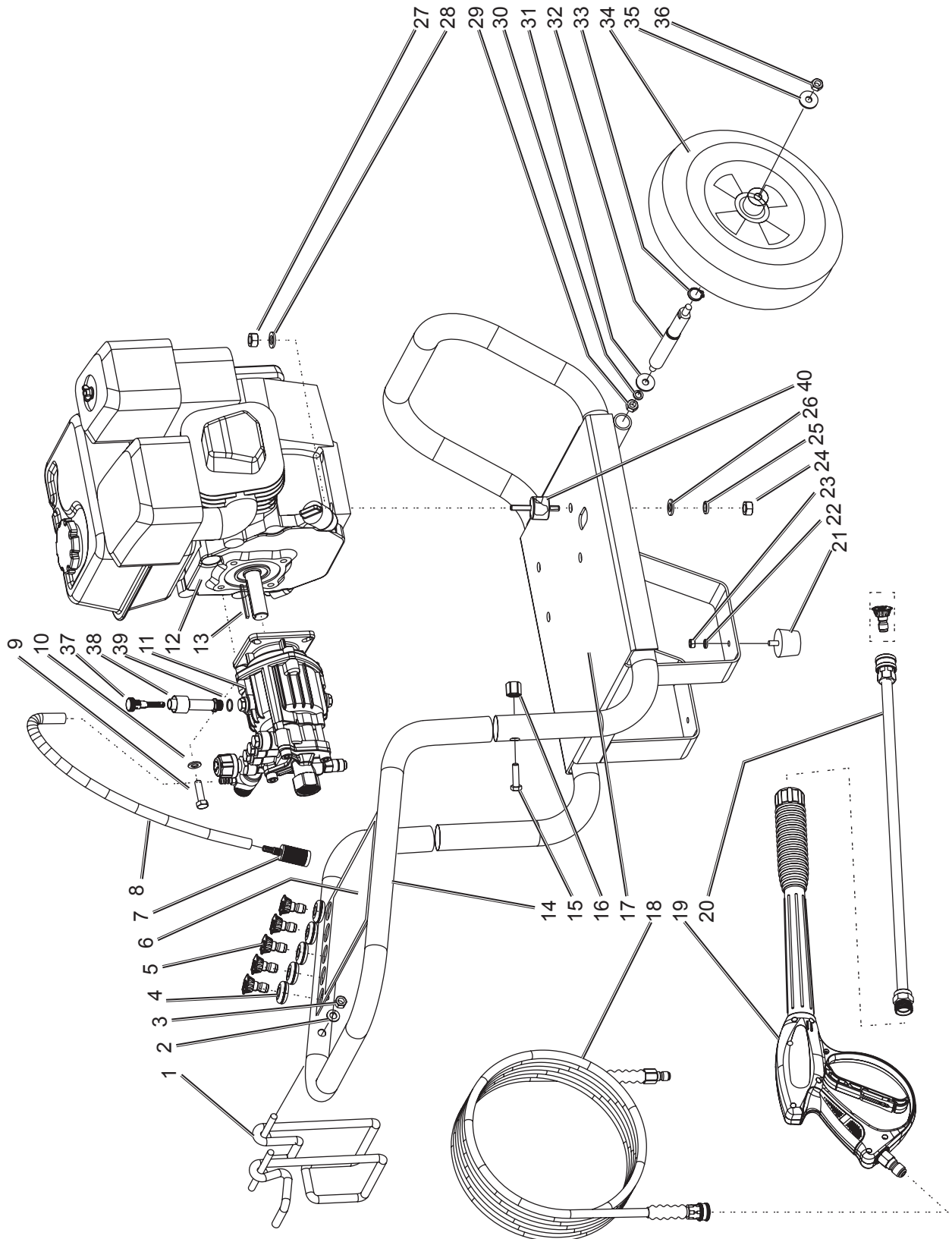

## Parts List A - Pump

Part	Description
1A	Screw M8x16
2A	Flange
3A	O-Ring 80x2,4
4A	Radial Shaft Seal
5A	Real Bearing
6A	Sheath
7A	Wobble Plate
8A	Front bearing
9A	Spring Disk
10A	15mm Plunger
11A	Plunger Spring
12A	Crankcase
13A	O-Ring 14.2x1.9
14A	Brass Pump Plug
15A	Oil Seal
16A	O-ring 15x2.2
17A	Spacer
18A	O-ring 22x2
19A	Pressure Ring
20A	Water seal
21A	Inlet valve plug

Part	Description
22A	Backup ring
23A	O-ring
24A	Check Valve
26A	Detergent Inlet Connector
27A	O-ring 4.47x1.78
28A	Ball
29A	Cone spring
30A	O-ring
31A	Outlet Valve
32A	Valve spring
33A	O-ring
34A	Siphon Body
36A	Outlet Connector
37A	Backup Ring
38A	O-ring
39A	Valve Core
40A	Pump Manifold
41A	Seal Gasket
42A	Water Inlet Body
43A	Thermal Relief Valve

Part	Description
44A	Pressure Regulator Knob
45A	Screw Plug
46A	Backup Ring
47A	O-ring
48A	Spring Holder
49A	Large Pressure Spring
50A	Small Pressure Spring
51A	Ball Holder
53A	Ball
52A	Valve Port
54A	O-ring
55A	Manifold Bolt
56A	Inlet Swivel Nut
57A	Clip Ring
58A	Water Filter
59A	Pump Breather Plug
60A	Dipstick
61A	Drain Plug
62A	O-ring

When ordering replacement parts from this list, the "A" suffix must be included in order to get the correct part.

# Assembly Diagram A - Pump

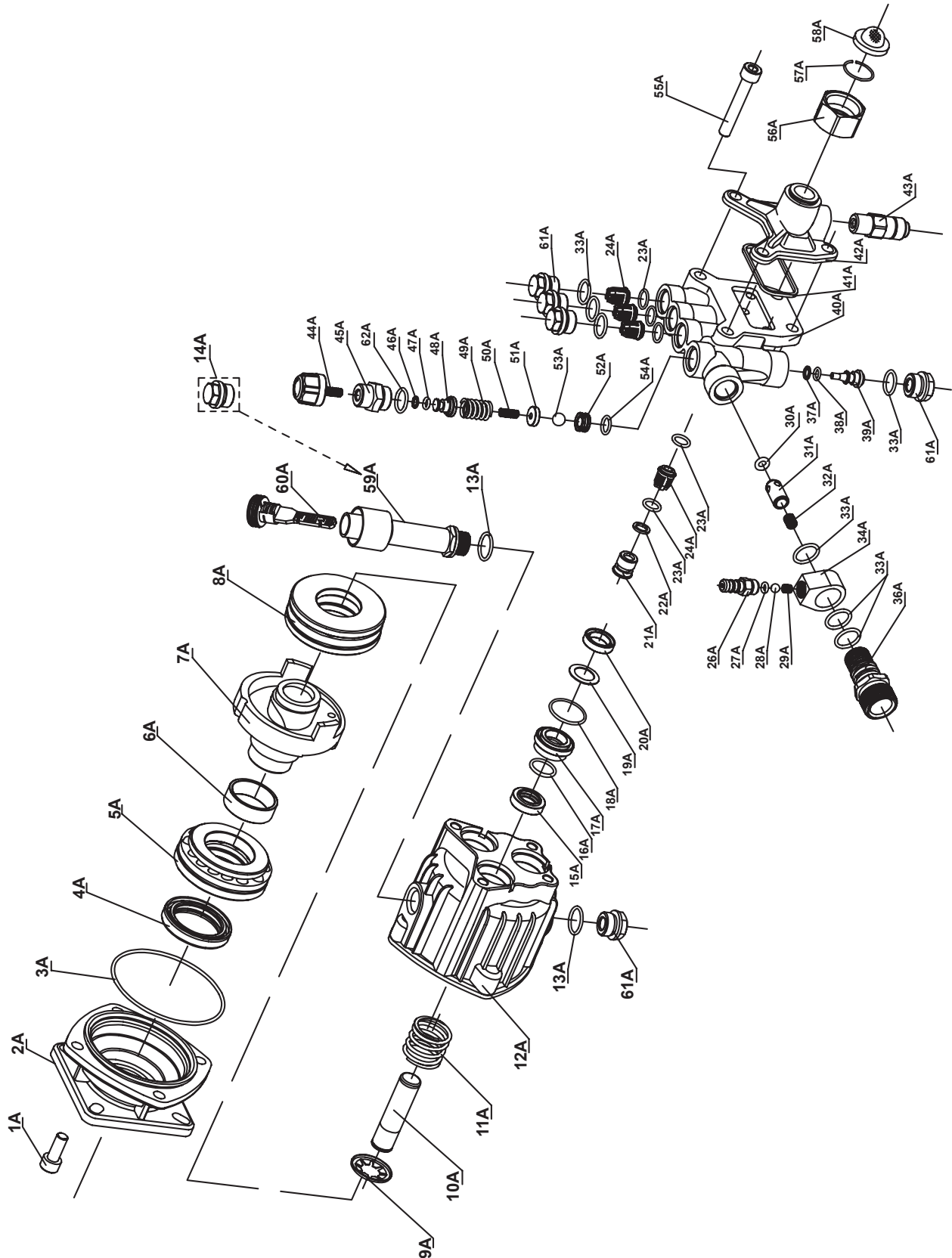

## Parts List & Diagram B - Cylinder Head

Part #	Description	Qty
1B	Cylinder Head Assembly	1
2B	Intake Valve Guide	1
3B	Exhaust Valve Guide	1
4B	Valve Guide Clip	1
5B	Cover	1
6B	Packing	1
7B	Breathing Tube	1
8B	Spark Plug	1
9B	Cylinder Gasket	1
10B	Muffler Gasket	1
11B	Pin	2
12B	Bolt 6x14	4
13B	Bolt 8x55	4
14B	Intake Bolt	2
15B	Exhaust Bolt	2
16B	Intake Valve Seat	1
17B	Exhaust Valve Seat	1
18B	Cylinder Head	1

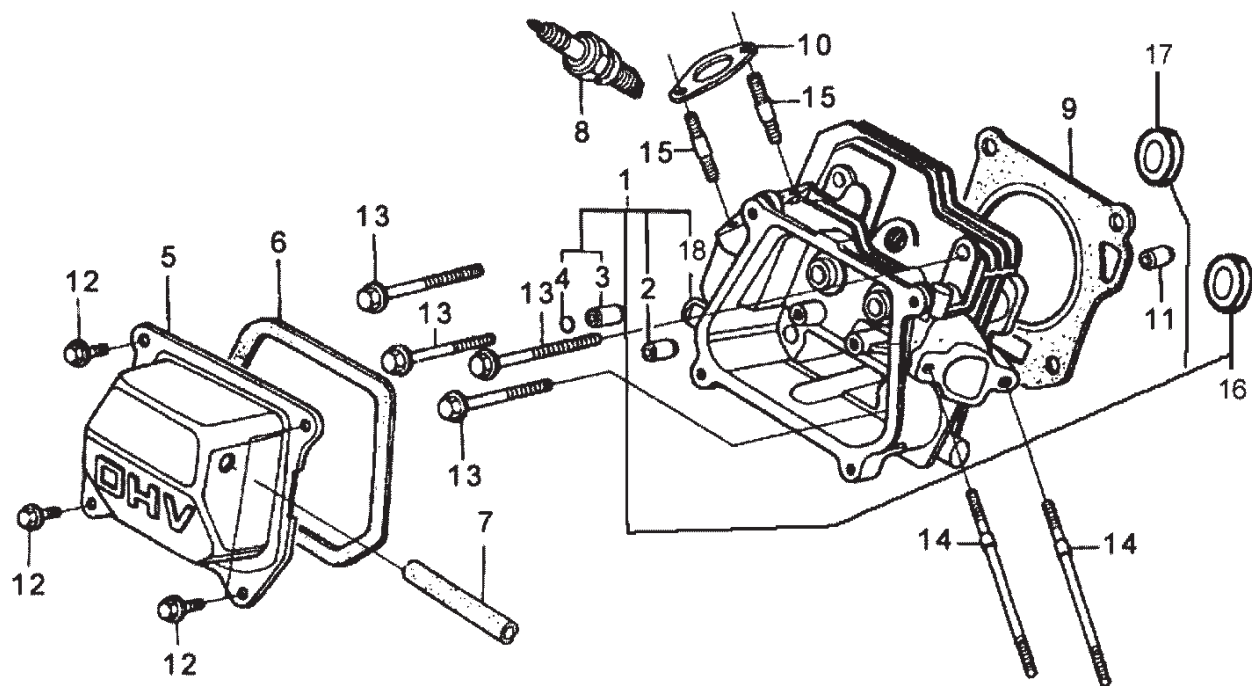

**Note:** When ordering parts for this component use the suffix "B".

**Note:** Some parts are listed and shown for illustration purposes only, and are not available individually as replacement parts.

## Parts List & Diagram C - Crankcase

Part #	Description	Qty
1C	Crank Case Assembly	1
2C	Oil Level Switch	1
3C	Gear Assembly	1
4C	Weight	2
5C	Gear	1
6C	Weight Pin	2
7C	Slider	1
8C	Shaft Arm	1
9C	Drain Plug Bolt	2
10C	Washer	2
11C	Washer	2

Part #	Description	Qty
12C	Clip	1
13C	Ball Bearing	1
14C	Oil Seal	1
15C	O-ring	1
16C	Nut	1
17C	Washer	1
18C	R-pin	1
19C	Bolt 6x12	3
20C	Shaft	1
21C	Assembly	1
22C	Oil Alarm	1

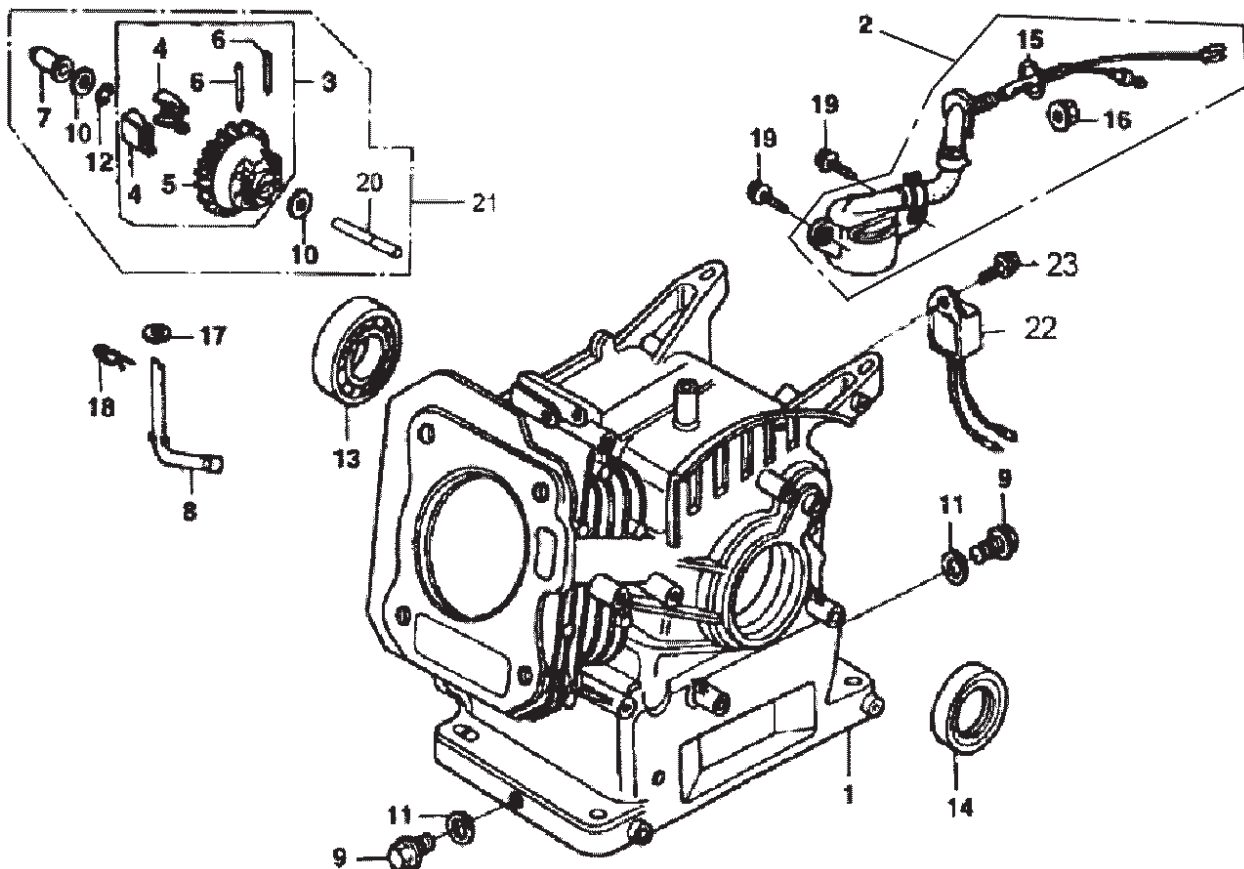

**Note:** When ordering parts for this component use the suffix "C".

**Note:** Some parts are listed and shown for illustration purposes only, and are not available individually as replacement parts.

## Parts List & Diagram D - Crankcase Cover

Part #	Description	Qty
1D	Bolt	6
2D	Oil Stick	1
3D	Packing	2
4D	Cover	1
5D	Oil Seal	1
6D	Bearing	1
7D	Pin	2
8D	Oil Filler Cap	1
9D	Packing Case Cover	1
10D	Oil Fill Assembly	1
11D	Cap Assembly	1

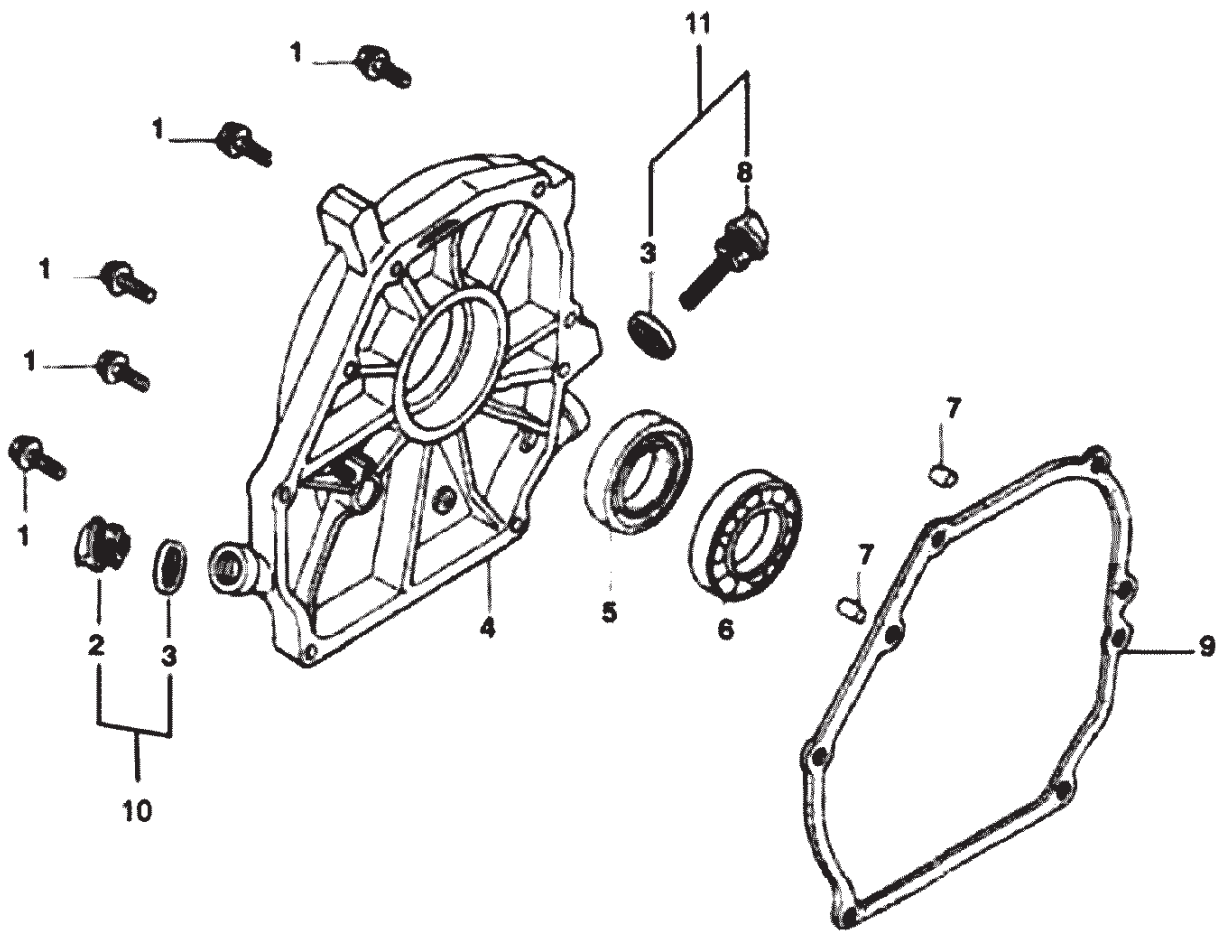

**Note:** When ordering parts for this component use the suffix "D".

**Note:** Some parts are listed and shown for illustration purposes only, and are not available individually as replacement parts.

## Parts List & Diagram E - Crankshaft/Piston

Part #	Description	Qty
1E	Ring Set	1
2E	Piston	1
3E	Pin	1
4E	Rod Assembly	1
5E	Crankshaft Assembly	1
6E	Bolt	2
7E	Clip	2
8E	Timing Gear	1
9E	Gear	1
10E	Crankshaft	1
11E	First Ring	1
12E	Second Ring	1
13E	Oil Ring	2
14E	Bushing Ring	1
15E	Connecting Rod	1
16E	Connecting Rod Cover	1
17E	Key	1

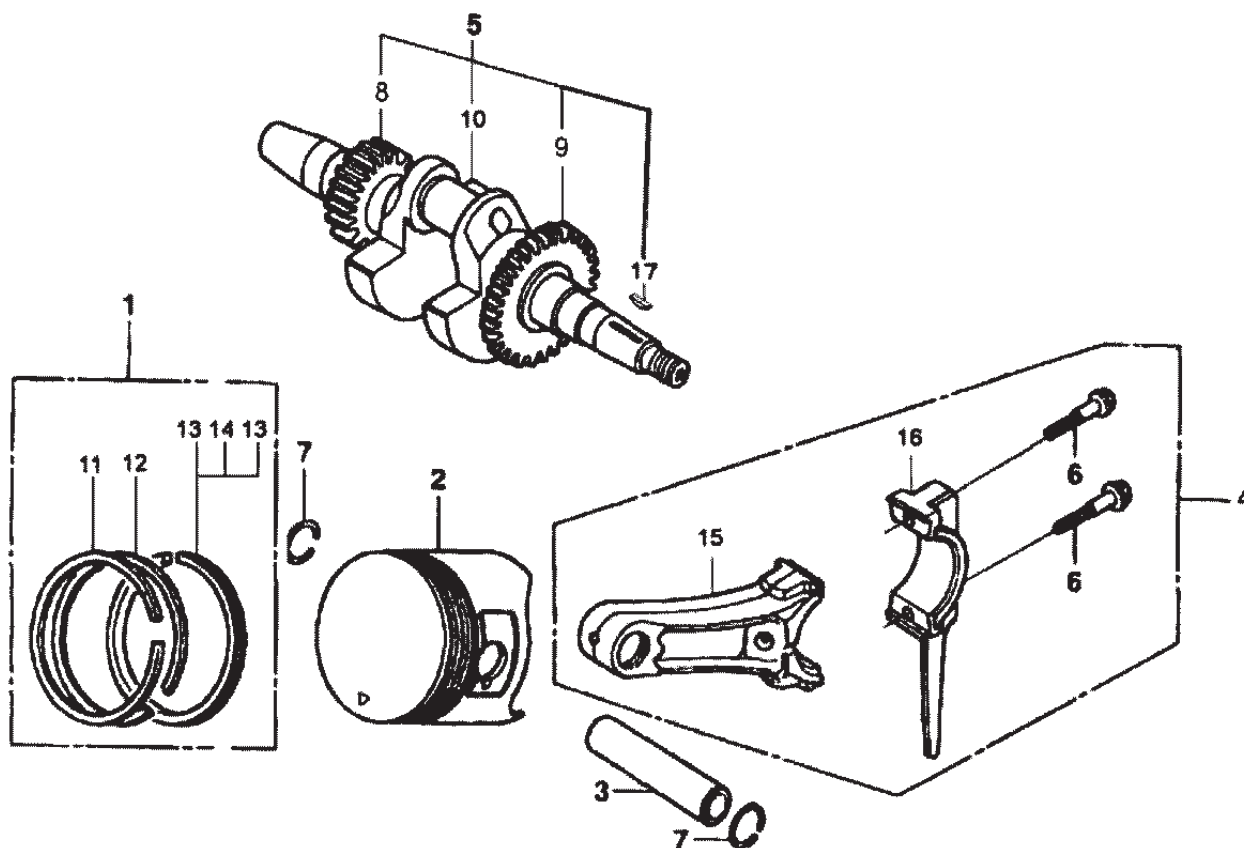

**Note:** When ordering parts for this component use the suffix "E".

**Note:** Some parts are listed and shown for illustration purposes only, and are not available individually as replacement parts.



## Parts List & Diagram F - Gas Distribution Adjustment System

Part #	Description	Qty
1F	Nut	2
2F	Rocker Arm	2
3F	Valve Rocker	2
4F	Pivot Bolt	2
5F	Plate Assembly	1
6F	Block Guide	2
7F	Push Rod Guide	1
8F	Push Rod	2
9F	Valve Lifter	2
10F	Rotator Valve	2
11F	Valve Spring Retainer	2
12F	Valve Spring	2
13F	Guide Seal	1

Part #	Description	Qty
14F	Camshaft Assembly	1
15F	Reducer Pin	1
16F	Reducer	1
17F	Matching Block Pin	2
18F	Matching Block	1
19F	Flying Block Pin	1
20F	Spring Pin	1
21F	Flying Block Spring	1
22F	Flying Block	1
23F	Camshaft	1
24F	Exhaust Valve	1
25F	Intake Valve	1

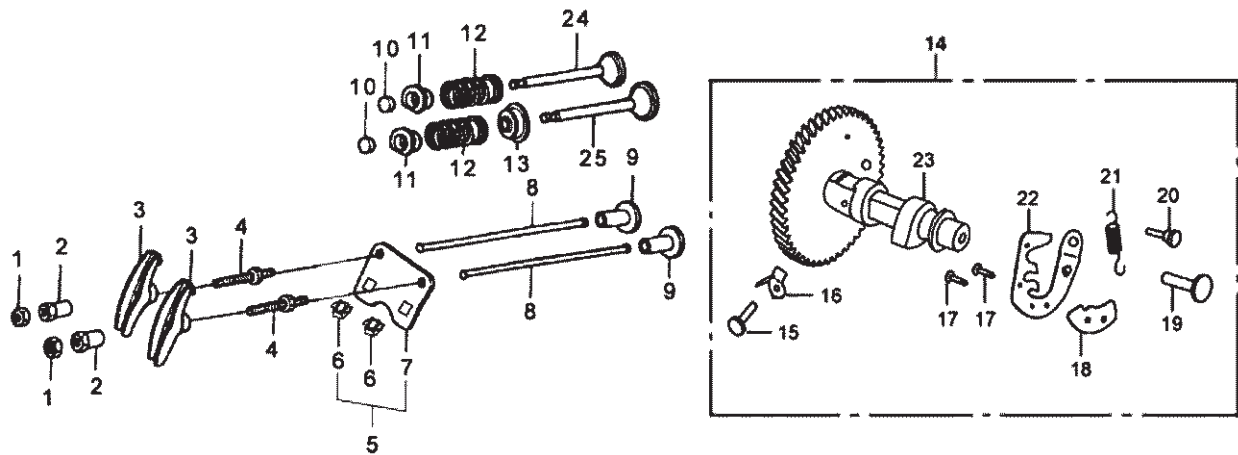

**Note:** When ordering parts for this component use the suffix "F".

**Note:** Some parts are listed and shown for illustration purposes only, and are not available individually as replacement parts.

## Parts List & Diagram G - Starter Subassembly

Part #	Description	Qty
1G	Starter Assembly	1
2G	Set Screw	1
3G	Ratchet Guide	1
4G	Friction Spring	1
5G	Starter Ratchet	2
6G	Return Spring	2
7G	Recoil Starter Reel	1
8G	Recoil Starter Spring	1
9G	Recoil Starter Knob	1
10G	Fan Cover	1
11G	Rope	1
12G	Bolt 6x8	3
13G	Bolt 6x10	4
14G	Fan Cover	1
15G	Switch Assembly	1
16G	Recoil Starter	1
17G	Fan Cover	1
18G	Stop Switch Assembly	1

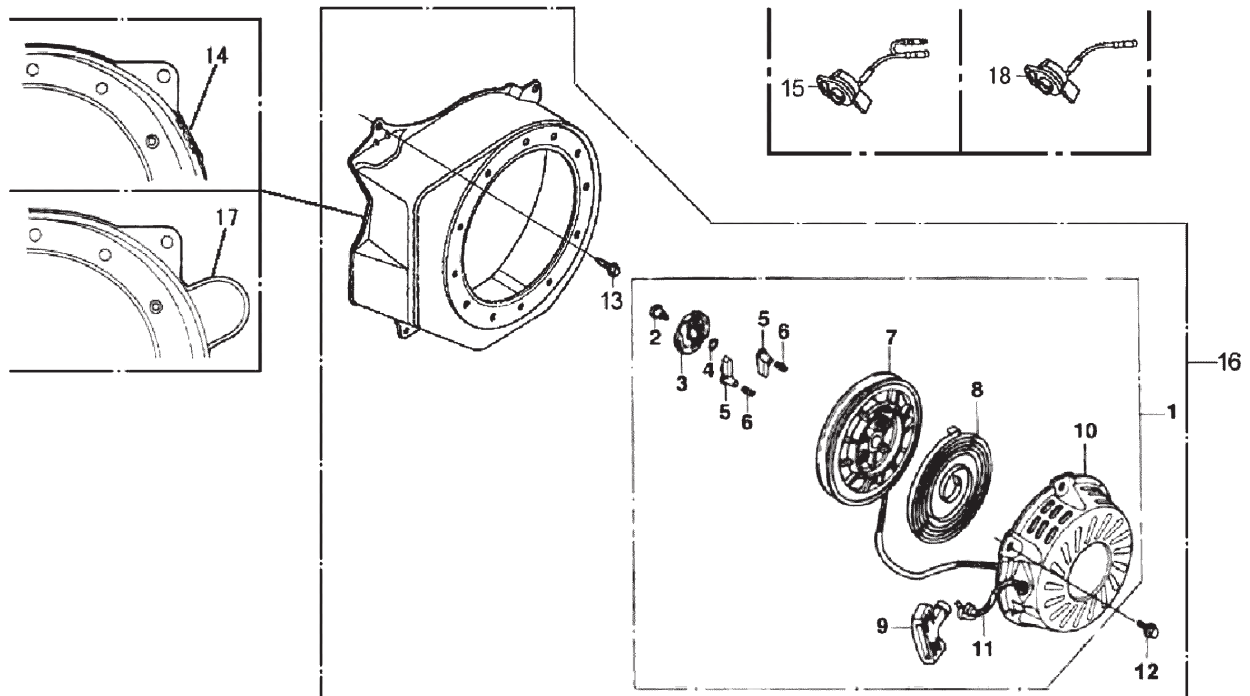

**Note:** When ordering parts for this component use the suffix “G”.

**Note:** Some parts are listed and shown for illustration purposes only, and are not available individually as replacement parts.

## Parts List & Diagram H - Diversion Assembly

Part #	Description	Qty
1H	Bolt 6x20	1
2H	Side Plate	1
3H	Bolt 6x8	2
4H	Shroud	1
5H	Side Plate	1
6H	Grommet	1

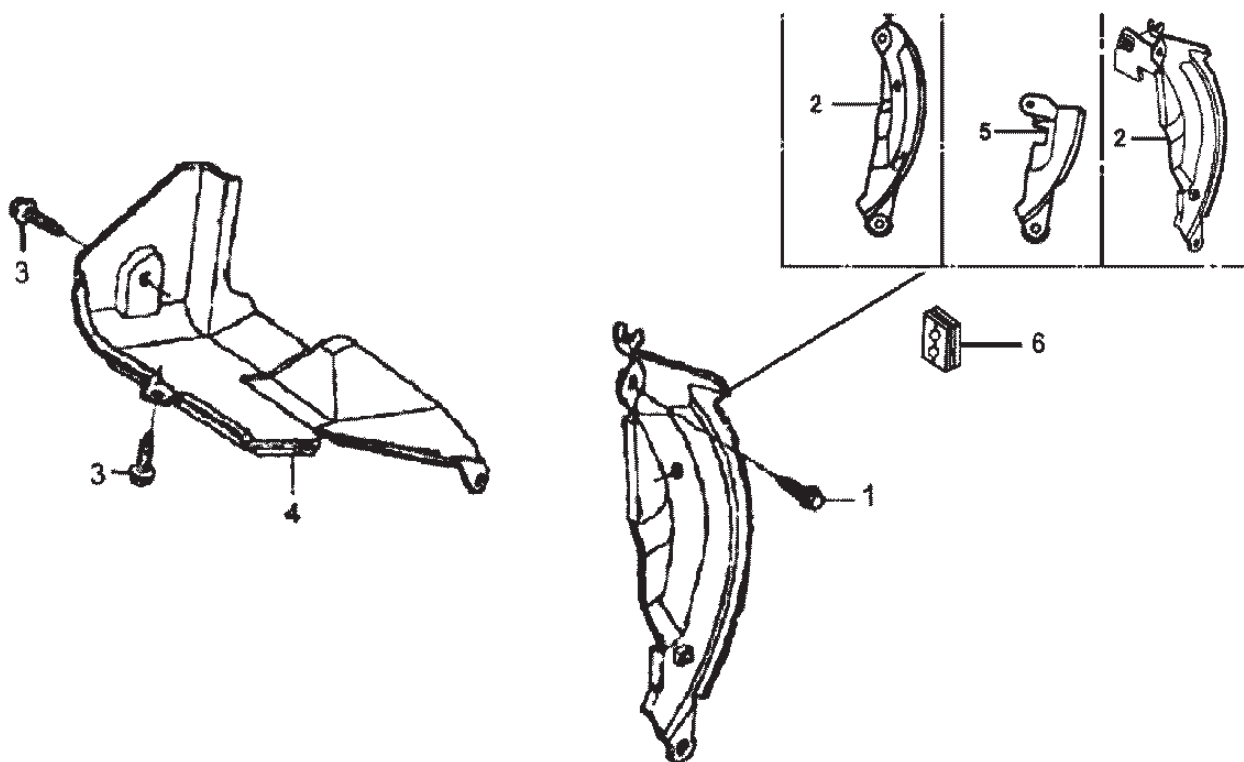

**Note:** When ordering parts for this component use the suffix “H”.

**Note:** Some parts are listed and shown for illustration purposes only, and are not available individually as replacement parts.

## Parts List & Diagram J - Carburetor

Part #	Description	Qty
1J	Carburetor Assembly	1
2J	Carburetor	1
3J	Main Nozzle	1
4J	Main Jet	1
5J	Float Valve	1
6J	Valve Set Spring	1
7J	Float	1
8J	Float Pin	1
9J	Oil Cup Gasket	1
10J	Oil Cup	1
11J	Gasket Bolt	1
12J	Bolt	1
13J	Drain Bolt	1
14J	Drain Bolt Gasket	1
15J	Fuel Strainer Cup	1
16J	Fuel Strainer Cup Packing	1
17J	Fuel Packing	1
18J	Lever	1

Part #	Description	Qty
19J	Lever Spring	1
20J	Setting Plate	1
21J	Screw 3x8	2
22J	Jet Set	1
23J	Pilot Jet Set	1
24J	Choke Lever Assembly	1
25J	Choke Lever	1
26J	Choke Lever Pin	1
27J	Choke Set	1
28J	Screw	1
29J	Screw Spring	1
30J	Throttle Stop Screw	1
31J	Air Cleaner	1
32J	Carburetor Packing	1
33J	Carburetor Insulation	1
34J	Packing	1
35J	Throttle Valve	1

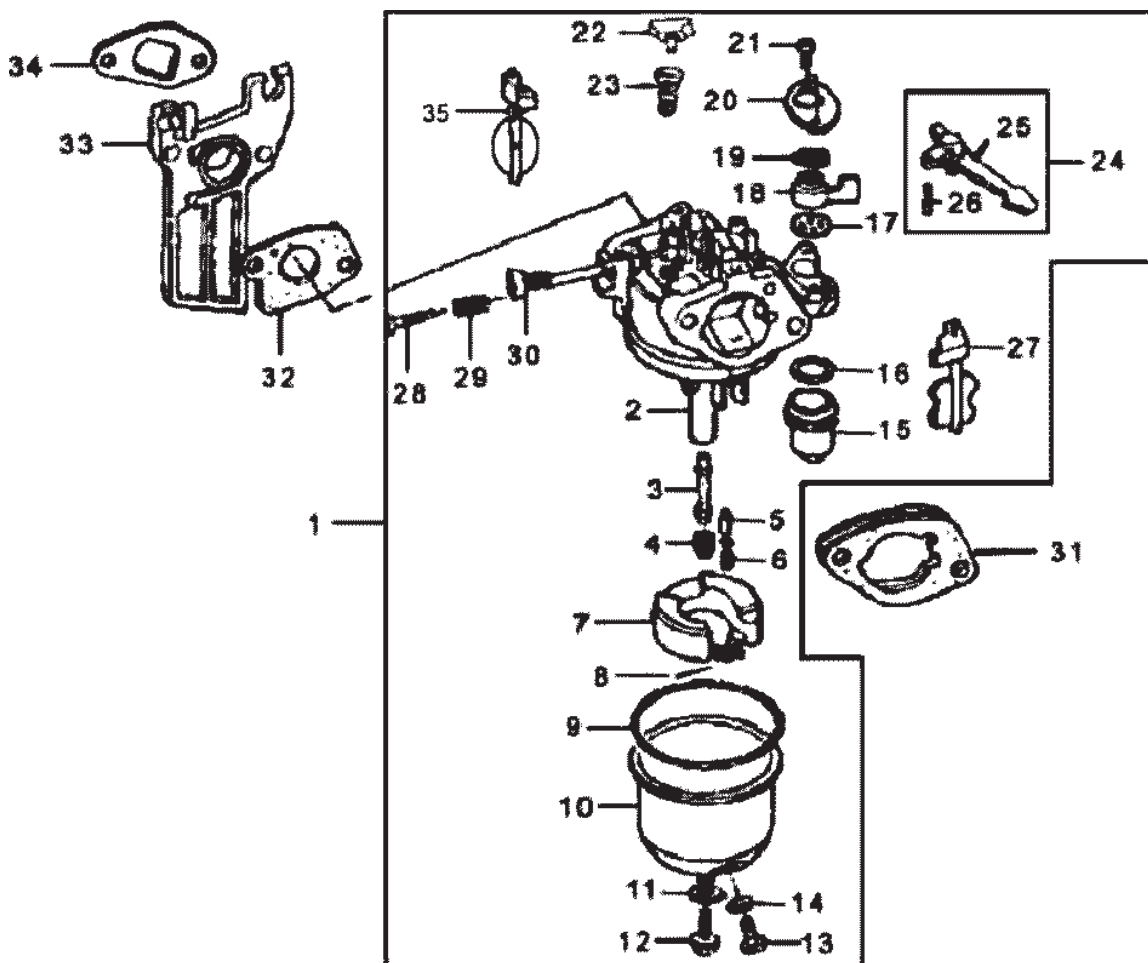

**Note:** When ordering parts for this component use the suffix "J".

## Parts List & Diagram K - Flywheel/Coil Assembly

Part	Description	Qty
1K	Ignition Assembly	1
2K	Ignition Coil	2
3K	Noise Suppression Cap Assembly	1
4K	Stop Switch Cord	1
5K	Bolt 6x30	2
6K	Flywheel Cover	1
7K	Charge Coil Assembly	1
8K	Cooling Fan	1
9K	Starter Pulley	1
10K	Nut	1
11K	Flywheel	1
12K	Charge Coil	1
13K	Bolt 6x35	2
14K	Cord Clamp	1
15K	Bolt 6x8	1

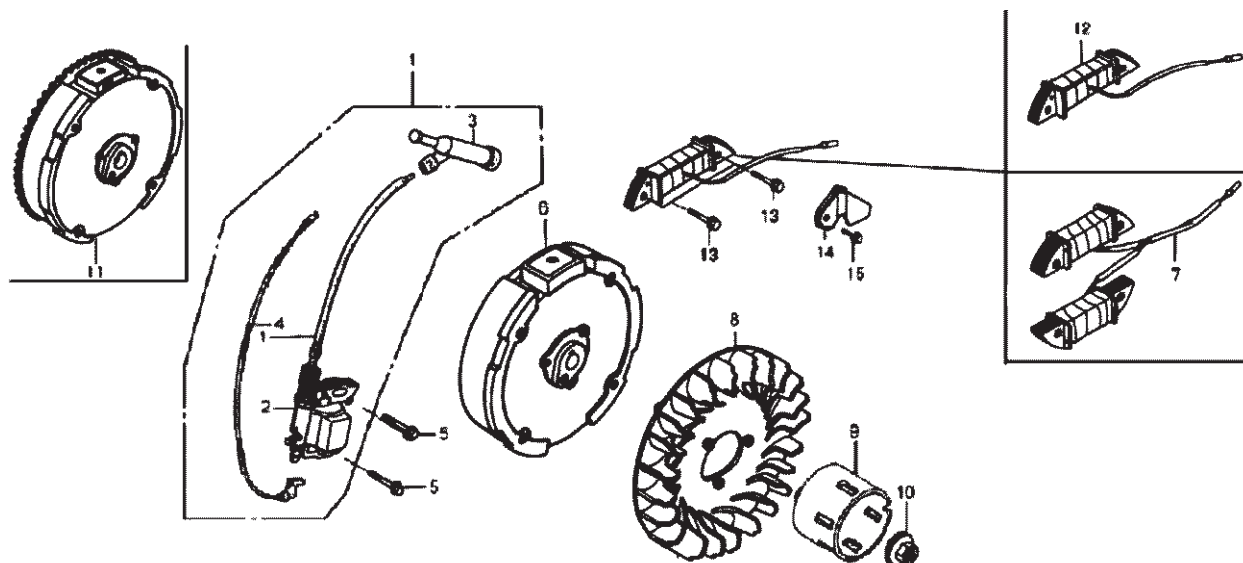

**Note:** When ordering parts for this component use the suffix “K”.

**Note:** Some parts are listed and shown for illustration purposes only, and are not available individually as replacement parts.

## Parts List & Diagram M - Control System

Part #	Description	Qty	Part #	Description	Qty
1M	Bolt	2	12M	Washer	1
2M	Spring	1	13M	Retainer Assembly	1
3M	Bolt	1	14M	Spring	1
4M	Arm	1	15M	Screw 5x35	
5M	Nut	1	16M	Cable Return Spring	1
6M	Throttle Return Spring	1	17M	Control Handle	1
7M	Rod	1	18M	Screw 5x25	1
8M	Control Assembly	1	19M	Back Plate	1
9M	Nut	1	20M	Screw 4x6	1
10M	Fixing Plate	1	21M	Locking Ring	1
11M	Washer	1	22M	Clip	1

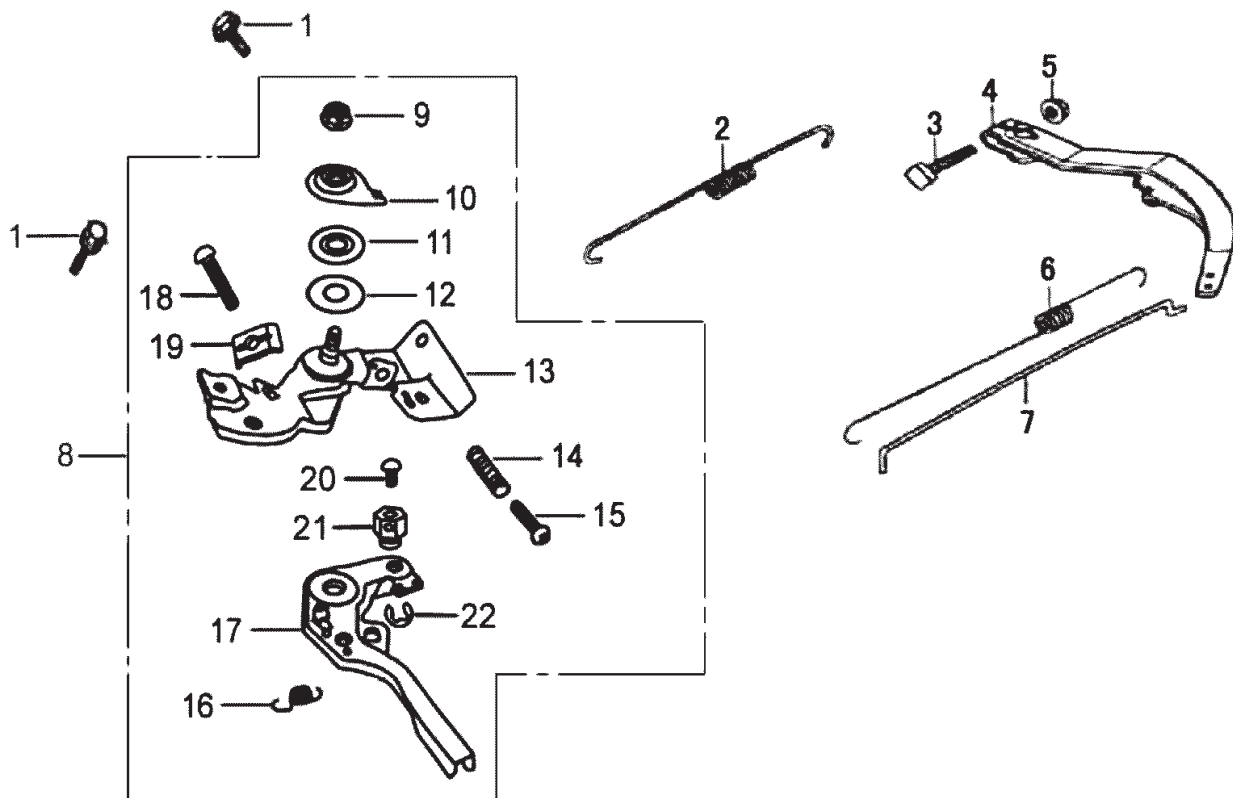

**Note:** When ordering parts for this component use the suffix "M".

**Note:** Some parts are listed and shown for illustration purposes only, and are not available individually as replacement parts.

## Parts List & Diagram N - Air Cleaner

Part	Description	Qty
1N	Air Cleaner Assembly	1
2N	Elbow	1
3N	Short Collar	2
4N	Long Collar	2
5N	Elbow Packing	1
6N	Bolt 6x20	1
7N	Nut 6mm	2
8N	Nut	2
9N	Air Cleaner Cover	1

Part	Description	Qty
10N	Air Cleaner Element Assembly	1
11N	Grommet	1
12N	Outer Filter	1
13N	Element	1
14N	Noise Silencer	1
15N	Air Cleaner Assembly	1
16N	Cover	1
17N	Screw	2

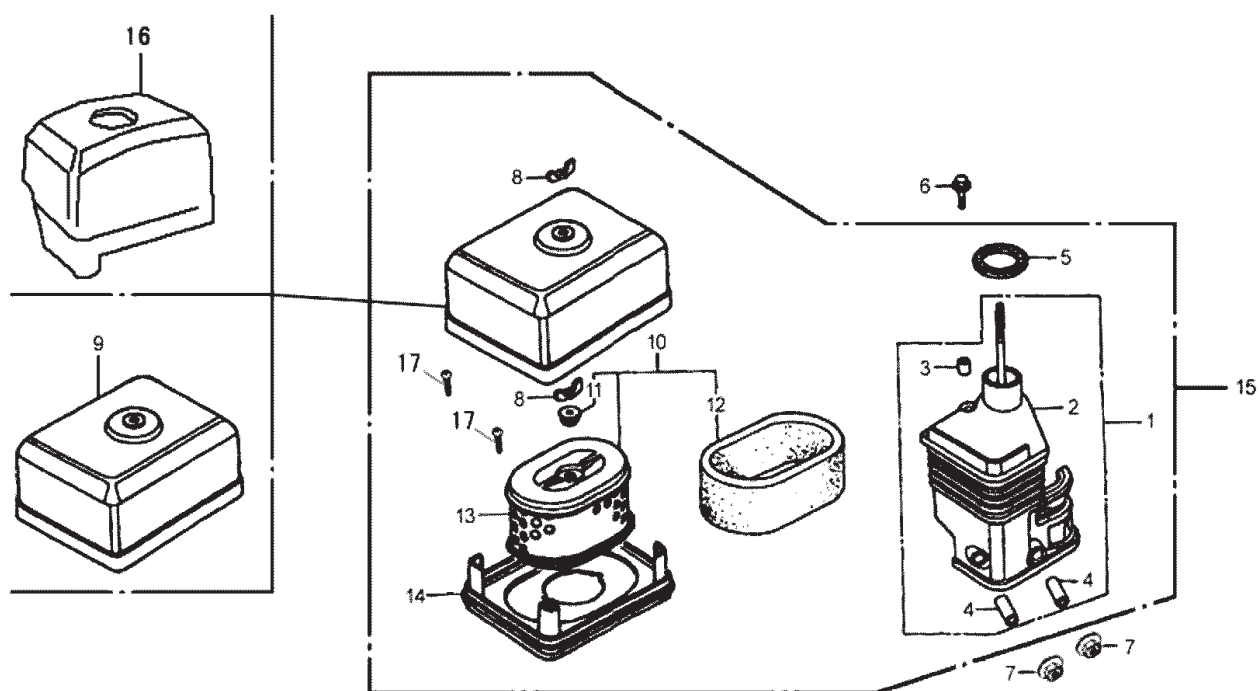

**Note:** When ordering parts for this component use the suffix "N".

**Note:** Some parts are listed and shown for illustration purposes only, and are not available individually as replacement parts.

## Parts List & Diagram P - Muffler

Part	Description	Qty.
1P	Muffler Assembly	1
2P	Gasket	1
3P	Air Valve	1
4P	Bolt	2

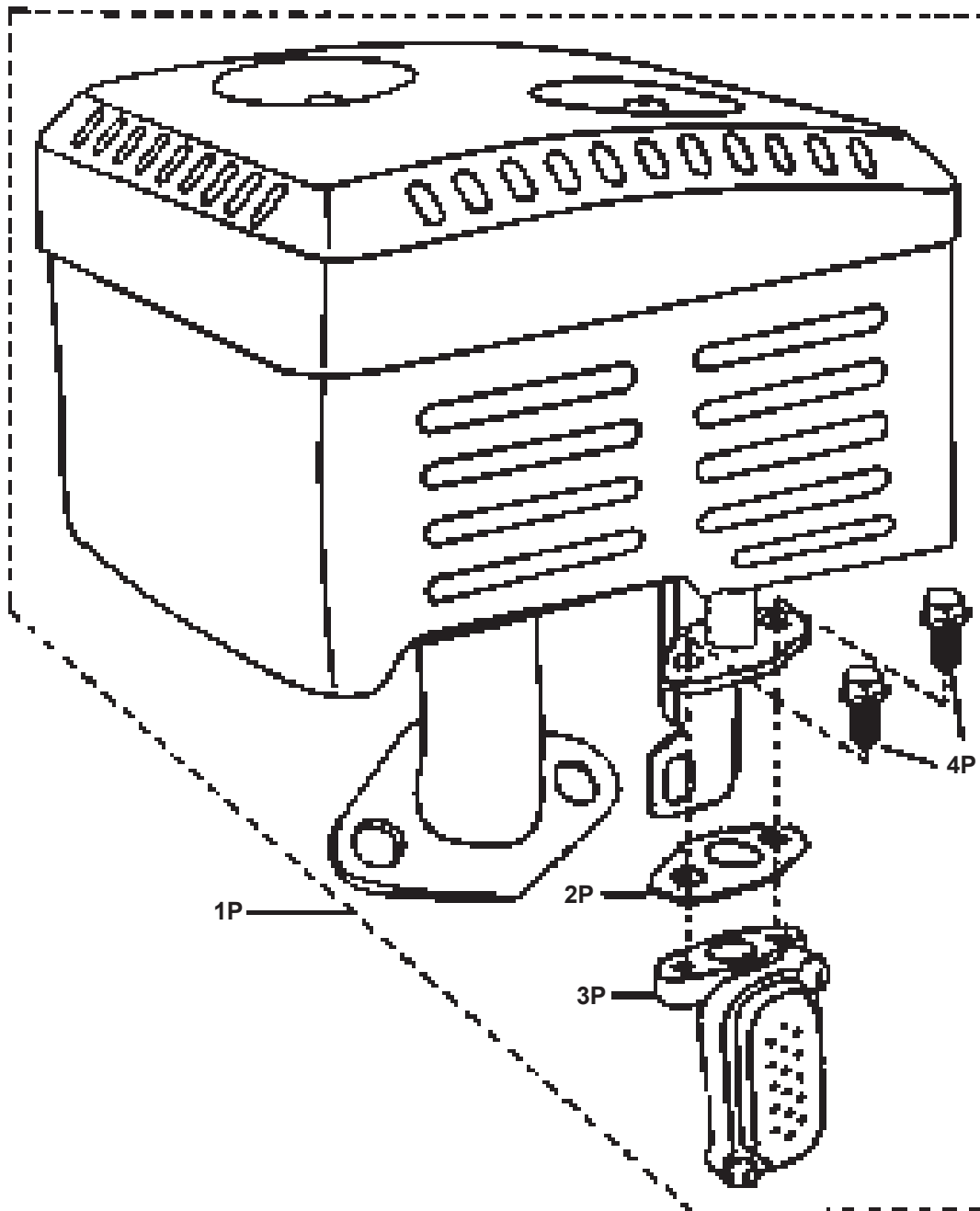

**Note:** When ordering parts for this component use the suffix "P".

**Note:** Some parts are listed and shown for illustration purposes only, and are not available individually as replacement parts.



## Parts List & Diagram R - Fuel Tank

Part	Description	Qty.
1R	Fuel Tank	1
2R	Gasket	1
3R	Gas Valve	1
4R	Cover	1
5R	Cap	1
6R	Filter	1

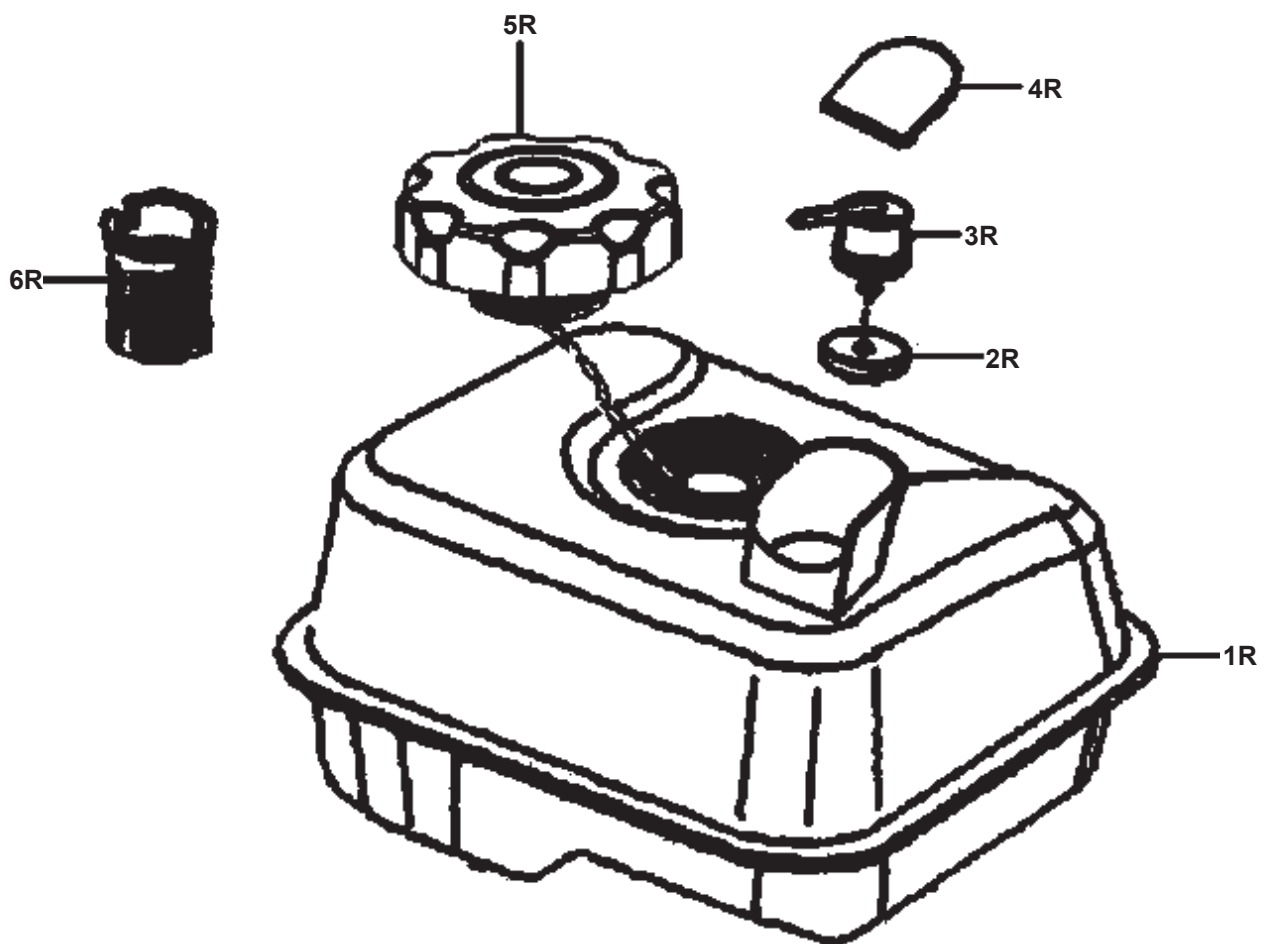

**Note:** When ordering parts for this component use the suffix "R".

**Note:** Some parts are listed and shown for illustration purposes only, and are not available individually as replacement parts.

## Parts List & Diagram S - Carbon Canister

Part	Description	Qty.
1S	Shroud	1
2S	Mounting Grommet	2
3S	Carbon Canister	1
4S	Canister Vent	1
5S	Canister Vent	1

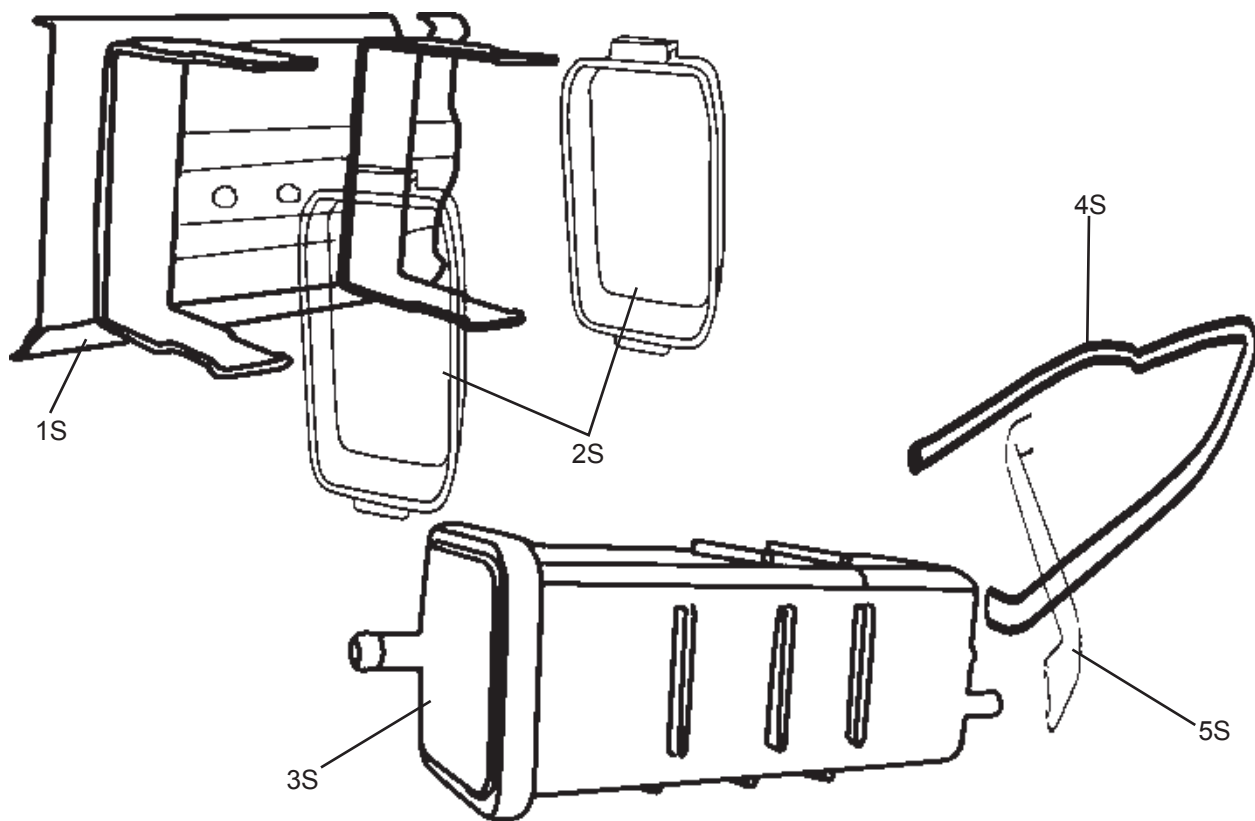

**Note:** When ordering parts for this component use the suffix "R".

**Note:** Some parts are listed and shown for illustration purposes only, and are not available individually as replacement parts.

---

## LIMITED 1 YEAR / 90 DAY WARRANTY

---

Harbor Freight Tools Co. makes every effort to assure that its products meet high quality and durability standards, and warrants to the original purchaser that for a period of ninety days from date of purchase that the engine/motor, the belts (if so equipped), and the blades (if so equipped) are free of defects in materials and workmanship. Harbor Freight Tools also warrants to the original purchaser, for a period of one year from date of purchase, that all other parts and components of the product are free from defects in materials and workmanship (90 days if used by a professional contractor or if used as rental equipment). This warranty does not apply to damage due directly or indirectly, to misuse, abuse, negligence or accidents, repairs or alterations outside our facilities, normal wear and tear, or to lack of maintenance. We shall in no event be liable for death, injuries to persons or property, or for incidental, contingent, special or consequential damages arising from the use of our product. Some states do not allow the exclusion or limitation of incidental or consequential damages, so the above limitation of exclusion may not apply to you. THIS WARRANTY IS EXPRESSLY IN LIEU OF ALL OTHER WARRANTIES, EXPRESS OR IMPLIED, INCLUDING THE WARRANTIES OF MERCHANTABILITY AND FITNESS.

To take advantage of this warranty, the product or part must be returned to us with transportation charges prepaid. Proof of purchase date and an explanation of the complaint must accompany the merchandise. If our inspection verifies the defect, we will either repair or replace the product at our election or we may elect to refund the purchase price if we cannot readily and

quickly provide you with a replacement. We will return repaired products at our expense, but if we determine there is no defect, or that the defect resulted from causes not within the scope of our warranty, then you must bear the cost of returning the product.

This warranty gives you specific legal rights and you may also have other rights which vary from state to state.

**3491 Mission Oaks Blvd.  
PO Box 6009 • Camarillo, CA 93011  
(800) 444-3353**

---

### Emission Control System Warranty

---

#### **California and United States Emission Control Defects Warranty Statement**

The California Air Resources Board (herein CARB), the United States Environmental Protection Agency (herein EPA), and Harbor Freight Tools (herein HFT) are pleased to explain the emission control system warranty on your 1995 and later Small Off-Road Engine (herein engine). In California, the engine must be designed, built and equipped to meet the State's stringent anti-smog standards. Elsewhere within the United States, new off-road, spark-ignition engines certified for model year 1997 and later, must meet similar standards set forth by the EPA. HFT must warrant the emission control system on your engine for the periods of time described below, provided there has been no abuse, neglect or improper maintenance of your engine.

Your emission control system may include parts such as the carburetor or fuel-injection system, and the ignition system. Also included may be hoses, belts, connectors and other emission-related assemblies.

Where a warrantable condition exists, HFT will repair your engine at no cost to you including diagnosis, parts and labor.

#### **Manufacturer's Warranty Coverage**

The 1995 and later engines are warranted for two (2) years. If any emission-related part on your engine is defective, the part will be repaired or replaced by HFT.

#### **Harbor Freight Tools Emission Control Defects Warranty Coverage**

Engines are warranted for a period of two (2) years relative to emission control parts defects, subject to the provisions set forth below. If any emission related part on your engine is defective, the part will be repaired or replaced by HFT.

#### **Owner's Warranty Responsibilities**

- As the engine owner, you are responsible for the performance of the required maintenance listed in your Owner's Manual. HFT recommends that you retain all receipts covering maintenance on your engine, but HFT cannot deny warranty

solely for the lack of receipts or for your failure to ensure the performance of all scheduled maintenance.

- As the engine owner, you should, however, be aware that HFT may deny you warranty coverage if your engine or a part has failed due to abuse, neglect, improper maintenance, or unapproved modifications.
- You are responsible for shipping your engine to a HFT warranty station as soon as a problem exists. Contact the HFT Customer Service department at the number below to make shipping arrangements. The warranty repairs should be completed in a reasonable amount of time, not to exceed 30 days.

If you have any questions regarding your warranty rights and responsibilities, you should contact the Harbor Freight Tools Customer Service Department at 1-800-444-3353.

### **Harbor Freight Tools Emission Control Defects Warranty Provisions**

#### **1. Length of Coverage**

HFT warrants to a first retail purchaser and each subsequent purchaser that the engine is free from defects in materials and workmanship that cause the failure of warranted parts for a period of two (2) years after the date of delivery to the first retail purchaser.

#### **2. No Charge Repair or Replacement**

Repair or replacement of any warranted part will be performed at no charge to the owner if the work is performed through a warranty station authorized by HFT. For emissions warranty service, contact the HFT Customer Service Department at 1-800-444-3353.

#### **3. Consequential Damages Coverage**

Coverage under this warranty shall also extend to the failure of any engine components caused by the failure of any warranted part while it is still covered under this warranty.

#### **4. Coverage Exclusions**

Warranty claims shall be filed in accordance with the provisions of the HFT warranty policy explained in the box at the top of the previous page. HFT shall not be liable for any loss of use of the engine, for any alternative usage, for any damage to goods, loss of time, or inconvenience. Warranty coverage shall also be excluded for any part which fails, malfunctions, or is damaged due to failure to follow the maintenance and operating instructions set forth in the Owner's Manual including, but not limited to:

- a) Use of parts which are not authorized by HFT
- b) Improper installation, adjustment or repair of the engine or of any warranted part unless performed by an authorized warranty center
- c) Failure to follow recommendations on fuel use contained in the Owner's Manual
- d) Improper or inadequate maintenance of any warranted parts
- e) Repairs performed outside of the authorized warranty service dealers
- f) Alterations by changing, adding to or removing parts from the engine.

#### **5. Service and Maintenance**

Component parts which are not scheduled for replacement as required maintenance or are scheduled only for regular inspection to the effect of "repair or replace as necessary"

are warranted for the warranty period. Any warranted part which is scheduled for replacement as required maintenance is warranted for the period of time up to the first scheduled replacement point for that part. Any replacement part, provided it is equivalent in durability and performance, may be used in performance of maintenance or repairs. The owner is responsible for commissioning a qualified technician/mechanic to perform all required maintenance, as outlined in the Inspection, Cleaning, and Maintenance section in this manual.

#### **6. Warranted Parts**

##### **1) Fuel Metering System**

- i) Carburetor and its internal parts.
- ii) Fuel pump (if so equipped).
- iii) Cold start enrichment system.

##### **2) Air Induction System**

- i) Intake pipe/manifold.
- ii) Air cleaner.

##### **3) Ignition System**

- i) Spark plug.
- ii) Magneto ignition system.

##### **4) Catalyst System (if so equipped)**

- i) Exhaust pipe stud.
- ii) Muffler.
- iii) Catalytic converter (if so equipped).

##### **5) Miscellaneous Items Used in Above Systems**

- i) Vacuum, temperature and time sensitive valves and switches.
- ii) Hoses, belts, connectors, and assemblies.

1. Remove Pump Oil Cap, check Pump's oil level and add SAE 30W oil if low. Replace with Pump Breather Plug. (Figure 1)  
Running without the pump breather plug can cause pump damage. (See oil fill instructions in manual or on product label.)
2. Check Dipstick for Engine oil level (Figure 2 A). Fill Engine with proper amount of oil if dipstick indicates low oil (Figure 2 B). Use SAE 10W-30 oil for air temperature of 32° F or above, SAE 5W-30 below 32° F. Fill Fuel Tank with 89 or higher octane unleaded gas mixed with fuel stabilizer (not included).
3. Connect and turn on water supply. Turn the pressure regulator counterclockwise to lower the output pressure. Point Spray Nozzle in safe direction and squeeze trigger to release all pressure from the pump.
4. Turn the red ignition switch to ON position (Figure 4).
5. Turn the Fuel Valve Lever (Gas pump symbol) to its OPEN position (Figure 5).
6. Set Throttle to slow (turtle symbol) and turn the engine choke lever to its CHOKE position for cold start. Set the choke lever in the 1/2 CHOKE position when starting a warm engine (Figure 5).
7. Grasp the starter handle, and pull slowly until resistance is felt (Figure 6). While holding the handle, allow the starter rope to rewind slowly. Then, pull the starter handle with a rapid, full arm stroke. Once again while holding the handle, allow the rope to rewind slowly. Repeat as needed until the engine starts.
8. After the Engine starts and warms up, slowly move the Choke Lever to its RUN position (Figure 5).  
**IMPORTANT:** Allow the Engine to run at no load, low pressure for five minutes after each start-up so Engine can stabilize.
9. Move the throttle up to operating speed (Fast) **EXCEPT DURING OPERATIONAL BREAK-IN PERIOD** (Figure 5). Turn the pressure regulator clockwise to raise the output pressure as needed.

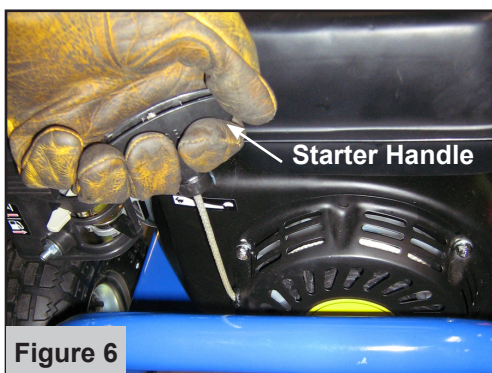
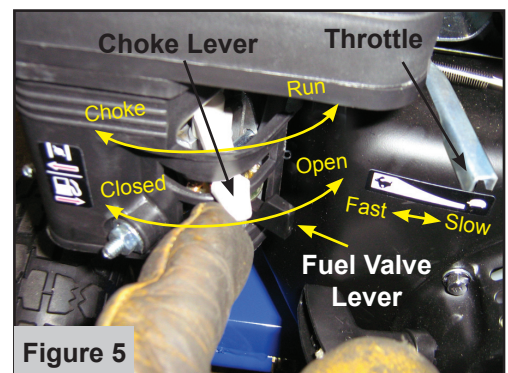
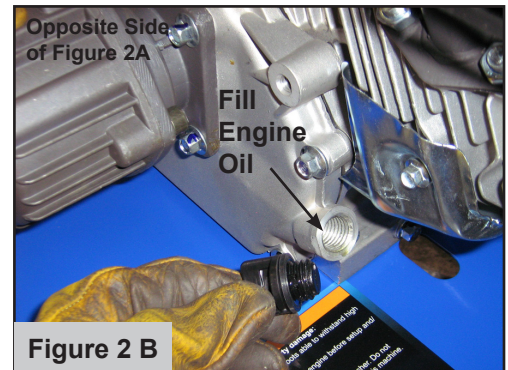
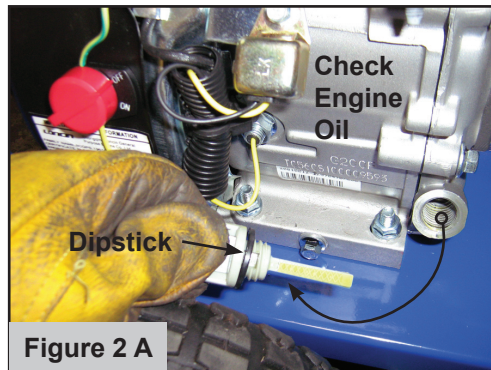
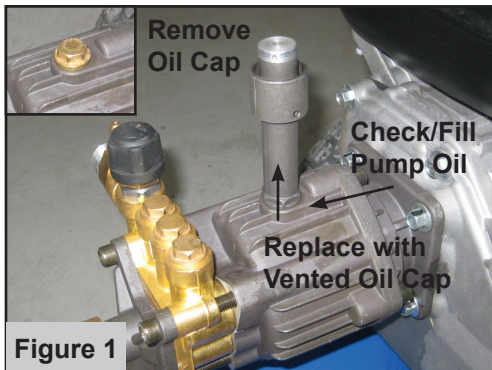

**OPERATIONAL BREAK-IN PERIOD**

Breaking-in the engine will help to ensure proper equipment and engine operation. The operational break-in period shall last about 3 hours of use.

During this period: Do not apply a heavy load to the equipment. Do not operate the engine at its maximum speed.

## Free Manuals Download Website

<http://myh66.com>

<http://usermanuals.us>

<http://www.somanuals.com>

<http://www.4manuals.cc>

<http://www.manual-lib.com>

<http://www.404manual.com>

<http://www.luxmanual.com>

<http://aubethermostatmanual.com>

Golf course search by state

<http://golfingnear.com>

Email search by domain

<http://emailbydomain.com>

Auto manuals search

<http://auto.somanuals.com>

TV manuals search

<http://tv.somanuals.com>