

CENTRAL MACHINERY®

1/2" BENCH TOP SHAPER/ROUTER

Model 32650

SET UP AND OPERATING INSTRUCTIONS



Visit our website at: <http://www.harborfreight.com>



**Read this material before using this product.
Failure to do so can result in serious injury.
SAVE THIS MANUAL.**

Copyright© 1998 by Harbor Freight Tools®. All rights reserved. No portion of this manual or any artwork contained herein may be reproduced in any shape or form without the express written consent of Harbor Freight Tools. Diagrams within this manual may not be drawn proportionally. Due to continuing improvements, actual product may differ slightly from the product described herein. Tools required for assembly and service may not be included.

For technical questions or replacement parts, please call 1-800-444-3353.

Manual Revised 10e

CONTENTS

IMPORTANT SAFETY INFORMATION	3	GENERAL OPERATING INSTRUCTIONS	18
GENERAL TOOL SAFETY WARNINGS	3	SHAPING AND ROUTING TECHNIQUES	18
GROUNDING INSTRUCTIONS	5	MAINTENANCE AND SERVICING ...	20
110-120 V~ GROUNDED TOOLS: TOOLS WITH THREE PRONG PLUGS	5	CLEANING, MAINTENANCE, AND LUBRICATION	20
SHAPER SAFETY WARNINGS	5	CARBON BRUSH REPLACEMENT	21
SPECIFICATIONS	8	TROUBLESHOOTING.....	22
UNPACKING	8	PARTS LIST	24
COMPONENTS	8	ASSEMBLY DIAGRAM	25
INSTRUCTIONS FOR PUTTING INTO USE	9	LIMITED 1 YEAR / 90 DAY WARRANTY	26
ASSEMBLY/MOUNTING	9		
MOUNTING.....	9		
INSTALLING THE HEIGHT KNOB	9		
OPERATING INSTRUCTIONS	10		
TOOL SET UP	10		
ADJUSTING THE MAIN SPINDLE HEIGHT.....	10		
REMOVING OR INSTALLING THE SHAPER SPINDLE.....	11		
TABLE INSERT	12		
INSTALLING SHAPER BITS.....	12		
INSTALLING ROUTER BITS	13		
GUARD AND GUIDE LOCATIONS	14		
FENCE.....	14		
RING GUARD.....	15		
CHIP DISCHARGE CHUTE.....	15		
RADIUS PIN	16		
MITER GAUGE.....	16		
SWITCH AND KEY	17		
WORK PIECE AND WORK AREA SET UP	17		

SAVE THIS MANUAL

Keep this manual for the safety warnings and precautions, assembly, operating, inspection, maintenance and cleaning procedures. Write the product's serial number in the back of the manual near the assembly diagram (or month and year of purchase if product has no number). Keep this manual and the receipt in a safe and dry place for future reference.

IMPORTANT SAFETY INFORMATION

In this manual, on the labeling, and all other information provided with this product:



This is the safety alert symbol. It is used to alert you to potential personal injury hazards. Obey all safety messages that follow this symbol to avoid possible injury or death.

DANGER

DANGER indicates a hazardous situation which, if not avoided, will result in death or serious injury.

WARNING

WARNING indicates a hazardous situation which, if not avoided, could result in death or serious injury.

CAUTION

CAUTION, used with the safety alert symbol, indicates a hazardous situation which, if not avoided, could result in minor or moderate injury.

NOTICE

NOTICE is used to address practices not related to personal injury.

CAUTION

CAUTION, without the safety alert symbol, is used to address practices not related to personal injury.

General Tool Safety Warnings



WARNING Read all safety warnings and instructions. Failure to follow the warnings and instructions may result in electric shock, fire and/or serious injury.

Save all warnings and instructions for future reference.

1. KEEP GUARDS IN PLACE and in working order.
2. REMOVE ADJUSTING KEYS AND WRENCHES. Form habit of checking to see that keys and adjusting wrenches are removed from tool before turning it on.
3. KEEP WORK AREA CLEAN. Cluttered areas and benches invite accidents.
4. DON'T USE IN DANGEROUS ENVIRONMENT. Don't use power tools in damp or wet locations, or expose them to rain. Keep work area well lighted.
5. KEEP CHILDREN AWAY. All visitors should be kept safe distance from work area.
6. MAKE WORKSHOP KID PROOF with padlocks, master switches, or by removing starter keys.
7. DON'T FORCE TOOL. It will do the job better and safer at the rate for which it was designed.

8. **USE RIGHT TOOL.** Don't force tool or attachment to do a job for which it was not designed.

RECOMMENDED MINIMUM WIRE GAUGE FOR EXTENSION CORDS (120 VOLT)				
NAMEPLATE AMPERES (at full load)	EXTENSION CORD LENGTH			
	25'	50'	100'	150'
0 – 6	18	16	16	14
6.1 – 10	18	16	14	12
10.1 – 12	16	16	14	12
12.1 – 16	14	12	Do not use.	

TABLE A

9. **USE PROPER EXTENSION CORD.** Make sure your extension cord is in good condition. When using an extension cord, be sure to use one heavy enough to carry the current your product will draw. An undersized cord will cause a drop in line voltage resulting in loss of power and overheating. Table A shows the correct size to use depending on cord length and nameplate ampere rating. If in doubt, use the next heavier gauge. The smaller the gauge number, the heavier the cord.
10. **WEAR PROPER APPAREL.** Do not wear loose clothing, gloves, neckties, rings, bracelets, or other jewelry which may get caught in moving parts. Non-slip footwear is recommended. Wear protective hair covering to contain long hair.
11. **ALWAYS USE SAFETY GLASSES.** Also use face or dust mask if cutting operation is dusty. Everyday eyeglasses only have impact resistant lenses, they are NOT safety glasses.
12. **SECURE WORK.** Use clamps or a vise to hold work when practical. It's safer than using your hand and it frees both hands to operate tool.

13. **DON'T OVERREACH.** Keep proper footing and balance at all times.
14. **MAINTAIN TOOLS WITH CARE.** Keep tools sharp and clean for best and safest performance. Follow instructions for lubricating and changing accessories.
15. **DISCONNECT TOOLS** before servicing; when changing accessories, such as blades, bits, cutters, and the like.
16. **REDUCE THE RISK OF UNINTENTIONAL STARTING.** Make sure switch is in off position before plugging in.
17. **USE RECOMMENDED ACCESSORIES.** Consult the owner's manual for recommended accessories. The use of improper accessories may cause risk of injury to persons.
18. **NEVER STAND ON TOOL.** Serious injury could occur if the tool is tipped or if the cutting tool is unintentionally contacted.
19. **CHECK DAMAGED PARTS.** Before further use of the tool, a guard or other part that is damaged should be carefully checked to determine that it will operate properly and perform its intended function – check for alignment of moving parts, binding of moving parts, breakage of parts, mounting, and any other conditions that may affect its operation. A guard or other part that is damaged should be properly repaired or replaced.
20. **DIRECTION OF FEED.** Feed work into a blade or cutter against the direction of rotation of the blade or cutter only.
21. **NEVER LEAVE TOOL RUNNING UNATTENDED. TURN POWER OFF.** Don't leave tool until it comes to a complete stop.

GROUNDING INSTRUCTIONS

⚠ WARNING TO PREVENT ELECTRIC SHOCK AND DEATH FROM INCORRECT GROUNDING WIRE CONNECTION READ AND FOLLOW THESE INSTRUCTIONS:



110-120 V~ Grounded Tools: Tools with Three Prong Plugs

1. In the event of a malfunction or breakdown, grounding provides a path of least resistance for electric current to reduce the risk of electric shock. This tool is equipped with an electric cord having an equipment-grounding conductor and a grounding plug. The plug must be plugged into a matching outlet that is properly installed and grounded in accordance with all local codes and ordinances.
2. Do not modify the plug provided – if it will not fit the outlet, have the proper outlet installed by a qualified electrician.
3. Improper connection of the equipment-grounding conductor can result in a risk of electric shock. The conductor with insulation having an outer surface that is green with or without yellow stripes is the equipment-grounding conductor. If repair or replacement of the electric cord or plug is necessary, do not connect the equipment-grounding conductor to a live terminal.
4. Check with a qualified electrician or service personnel if the grounding instructions are not completely understood, or if in doubt as to whether the tool is properly grounded.
5. Use only 3-wire extension cords that have 3-prong grounding plugs and

REV 10e

SKU 32650

For technical questions, please call 1-800-444-3353.

3-pole receptacles that accept the tool's plug.

6. Repair or replace damaged or worn cord immediately.

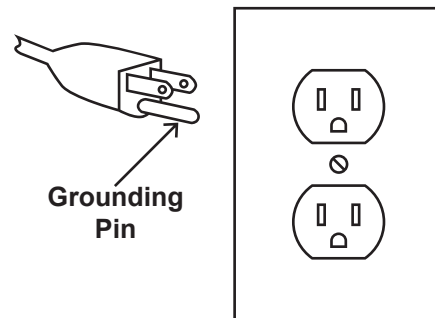

125 V~ 3-Prong Plug and Outlet
(for up to 125 V~ and up to 15 A)

7. This tool is intended for use on a circuit that has an outlet that looks like the one illustrated above in **125 V~ 3-Prong Plug and Outlet**. The tool has a grounding plug that looks like the plug illustrated above in **125 V~ 3-Prong Plug and Outlet**.
8. The outlet must be properly installed and grounded in accordance with all codes and ordinances.
9. Do not use an adapter to connect this tool to a different outlet.

Shaper Safety Warnings

For Your Own Safety Read Instruction Manual Before Operating Shaper

1. Wear eye protection.
2. Be sure keyed washer is directly under spindle nut and spindle nut is tight.
3. Feed work piece against rotation of cutter.
4. Do not use awkward hand positions.
5. Keep fingers away from revolving cutter – use fixtures when necessary.

Page 5

6. Use overhead guard when fence is not in place.
7. **DO NOT OPERATE WITH ANY GUARD DISABLED, DAMAGED, OR REMOVED. Moving guards must move freely and close instantly.**
8. The use of accessories or attachments not recommended by the manufacturer may result in a risk of injury to persons.
9. When servicing use only identical replacement parts.
10. Only use safety equipment that has been approved by an appropriate standards agency. Unapproved safety equipment may not provide adequate protection. Eye protection must be ANSI-approved and breathing protection must be NIOSH-approved for the specific hazards in the work area.
11. Industrial applications must follow OSHA guidelines.
12. Maintain labels and nameplates on the tool. These carry important safety information. If unreadable or missing, contact Harbor Freight Tools for a replacement.
13. Avoid unintentional starting. Prepare to begin work before turning on the tool.
14. People with pacemakers should consult their physician(s) before use. Electromagnetic fields in close proximity to heart pacemaker could cause pacemaker interference or pacemaker failure.
15. **WARNING:** Some dust created by power sanding, sawing, grinding, drilling, and other construction activities, contains chemicals known [to the State of California] to cause cancer, birth defects or other reproductive harm. Some examples of these chemicals are:
 - Lead from lead-based paints
 - Crystalline silica from bricks and cement or other masonry products
 - Arsenic and chromium from chemically treated lumber
 Your risk from these exposures varies, depending on how often you do this type of work. To reduce your exposure to these chemicals: work in a well ventilated area, and work with approved safety equipment, such as those dust masks that are specially designed to filter out microscopic particles. (California Health & Safety Code § 25249.5, *et seq.*)
16. **WARNING:** Handling the cord on this product will expose you to lead, a chemical known to the State of California to cause cancer, and birth defects or other reproductive harm. Wash hands after handling. (California Health & Safety Code § 25249.5, *et seq.*)
17. The warnings, precautions, and instructions discussed in this instruction manual cannot cover all possible conditions and situations that may occur. It must be understood by the operator that common sense and caution are factors which cannot be built into this product, but must be supplied by the operator.

Vibration Safety

This tool vibrates during use. Repeated or long-term exposure to vibration may cause temporary or permanent physical injury, particularly to the hands, arms and shoulders. To reduce the risk of vibration-related injury:

1. Anyone using vibrating tools regularly or for an extended period should first be examined by a doctor and then have regular medical check-ups to ensure medical problems are not being caused or worsened from use. Pregnant

REV 10e

women or people who have impaired blood circulation to the hand, past hand injuries, nervous system disorders, diabetes, or Raynaud's Disease should not use this tool. If you feel any medical or physical symptoms related to vibration (such as tingling, numbness, and white or blue fingers), seek medical advice as soon as possible.

2. Do not smoke during use. Nicotine reduces the blood supply to the hands and fingers, increasing the risk of vibration-related injury.
3. Wear suitable gloves to reduce the vibration effects on the user.
4. Use tools with the lowest vibration when there is a choice between different processes.
5. Include vibration-free periods each day of work.
6. Grip tool as lightly as possible (while still keeping safe control of it). Let the tool do the work.
7. To reduce vibration, maintain the tool as explained in this manual. If any abnormal vibration occurs, stop use immediately.



**SAVE THESE
INSTRUCTIONS.**

SPECIFICATIONS

Electrical Input	120 V~, 60 Hz, 7/8 HP
Motor No Load Speed	11,500 RPM
Max. Accessory Diameter	2"
Shank Diameter	Router: 1/4" Shaper: 1/2"
Table Top	11-3/4" x 9-3/4" surface



UNPACKING

When unpacking, make sure that the item is intact and undamaged. If any parts are missing or broken, please call Harbor Freight Tools at 1-800-444-3353 as soon as possible.

Components

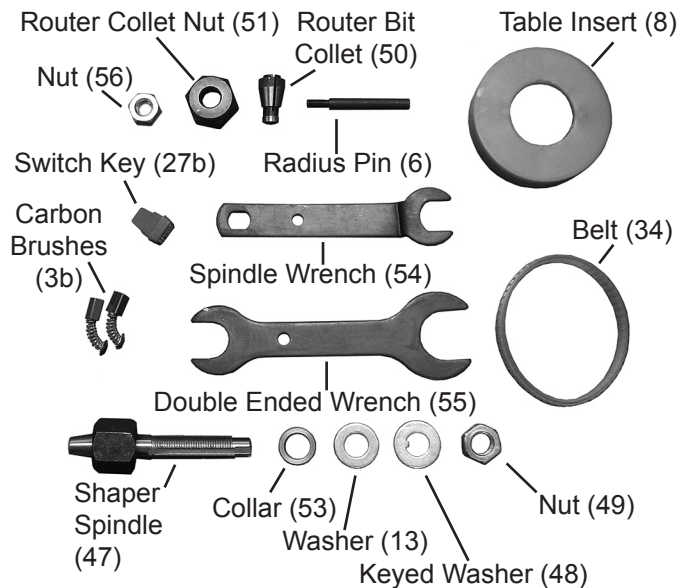
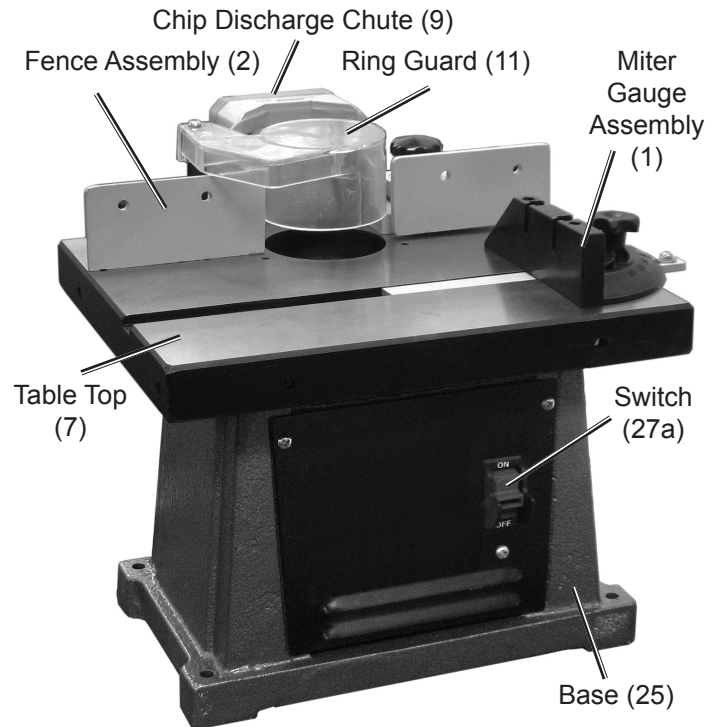

Figure 1

INSTRUCTIONS FOR PUTTING INTO USE



Read the **ENTIRE IMPORTANT SAFETY INFORMATION** section at the beginning of this manual including all text under subheadings therein before set up or use of this product.

WARNING

TO PREVENT SERIOUS INJURY

FROM ACCIDENTAL OPERATION:

Turn the Power Switch of the tool to its "OFF" position and unplug the tool from its electrical outlet before assembling or making any adjustments to the tool.

Note: For additional information regarding the parts listed in the following pages, refer to the Assembly Diagram near the end of this manual.

Assembly/Mounting

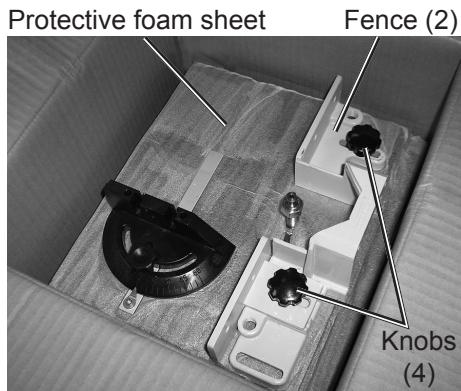

Figure 2

The Shaper/Router is packaged with a protective foam sheet covering the table top and the fence, secured in place on the table. Remove the Shaper/Router from the box then unthread the Knobs (4) holding the Half and Long Fence (2a and 2b) pieces from the Table Top (7). Discard the foam sheet.

REV 10e

SKU 32650

For technical questions, please call 1-800-444-3353.

Page 9

Mounting

Mount the Shaper/Router to a permanent location such as a work bench, or to a portable plywood base. If mounting to plywood, use a good grade of plywood or chipboard at least 3/4" thick.

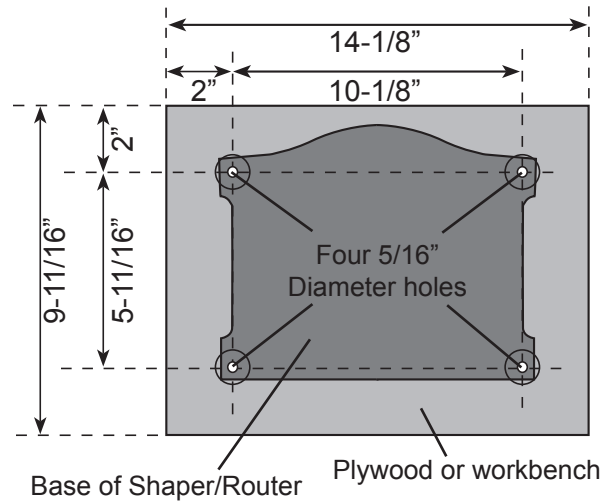

Figure 3

To Mount the Shaper/Router, use the above dimensions to mark the drilling locations on the plywood or workbench, allowing at least 2" of clearance on all sides. Drill four 5/16" diameter holes and attach the Shaper/Router using grade 5 or better 1/4" bolts, flat washers and self locking nuts (sold separately). Be sure to purchase bolts which are long enough to reach through the Shaper/Router Base, the thickness of the Plywood or workbench top, and allow for the washers and nuts.

WARNING: If you mount the Shaper/Router on a portable base, before each use, clamp the board securely to a workbench or supporting surface.

Installing the Height Knob

The Stud (17) for the Height Knob (16) is located on the back of the Base (25) and is packaged with a Nut (56) and Washer (18).

To install the Height Knob:

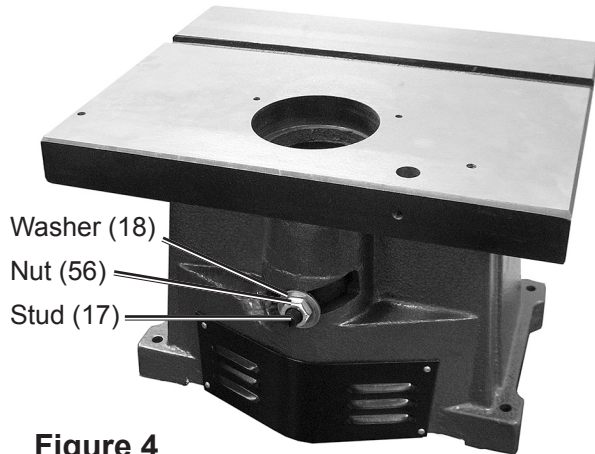

Figure 4

- a. Unthread the Shipping Nut (56) from the Stud counterclockwise and remove it from the Stud.

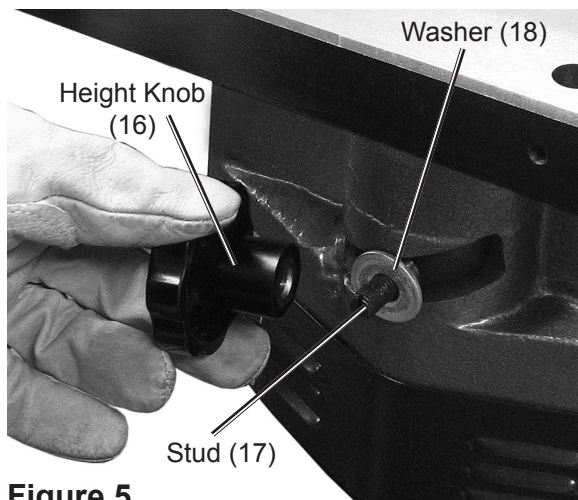

Figure 5

- b. Leave the Washer in place and thread the Height Knob (16) onto the Stud clockwise until it is secure.

OPERATING INSTRUCTIONS



Read the **ENTIRE IMPORTANT SAFETY INFORMATION** section at the beginning of this manual including all text under subheadings therein before set up or use of this product.

Tool Set Up

WARNING TO PREVENT SERIOUS INJURY

FROM ACCIDENTAL OPERATION:

Turn the Power Switch of the tool to its "OFF" position, pull out the Switch Key (27b), and unplug the tool from its electrical outlet before performing any inspection, maintenance, or cleaning procedures.

TO PREVENT SERIOUS INJURY: DO NOT OPERATE WITH ANY GUARD DISABLED, DAMAGED, OR REMOVED.

Adjusting the Main Spindle Height

The Main Spindle (43) can be adjust up or down by 3/4".

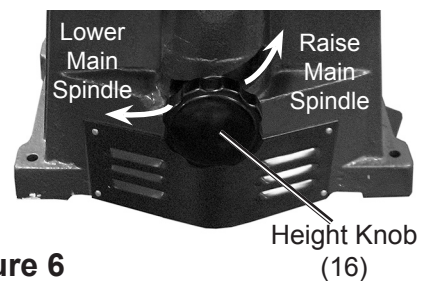

Figure 6

To adjust the height of the Main Spindle (43) turn the Height Knob (16) counter clockwise and slide the Knob to the left to lower, or the right to raise, the height of the Main Spindle. When it is the desired height, tighten the Height Knob clockwise until it is secure.

Removing or Installing the Shaper Spindle

The Shaper/Router is packaged with the Shaper Spindle (47) installed so that the unit is ready for use as a shaper. To use the unit as a router, the Shaper Spindle must be removed. Reinstall the Shaper Spindle when using shaper cutters.

To remove the Shaper Spindle:

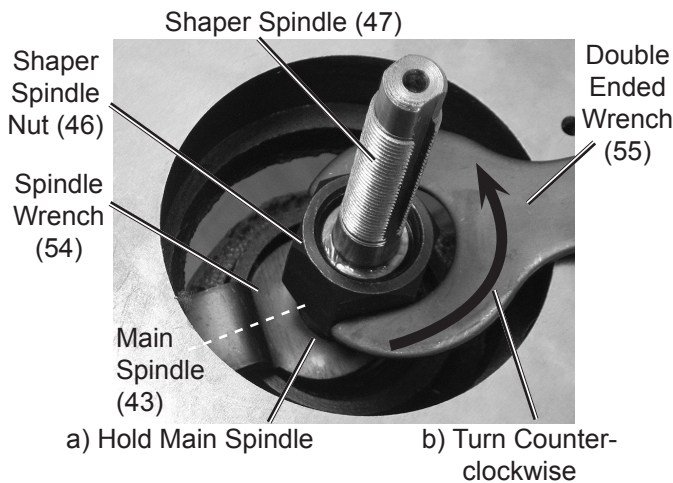
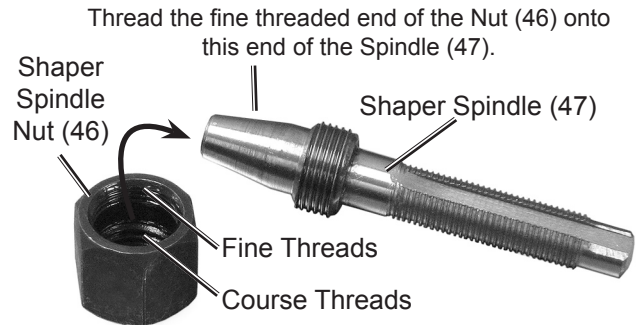

Figure 7

Hold the Main Spindle (43) with the Spindle Wrench (54) and the Shaper Spindle Nut (46) with the Double Ended Wrench (55). Turn the Double Ended Wrench counter clockwise to unthread the Nut from the Main Spindle.

Note: Insert the Spindle Wrench from under the Table Top (7) and the Double Ended Wrench from above the Table Top. You may need to adjust the Main Spindle height for easier access.

To Install the Shaper Spindle:



1. Thread the Shaper Spindle Nut (46) onto the Spindle. The Nut has one end with fine threads and the other with course threads. Match the fine threads with the Shaper Spindle. (The course threads fit the Main Spindle (43)). **BE CAREFUL NOT TO SCREW THE NUT ONTO THE SHAPER SPINDLE WITH THE COARSE THREADS OR YOU WILL DAMAGE BOTH PARTS.** Thread the Nut onto the Shaper Spindle until the threads of the Spindle reach the coarse threads of the Nut.

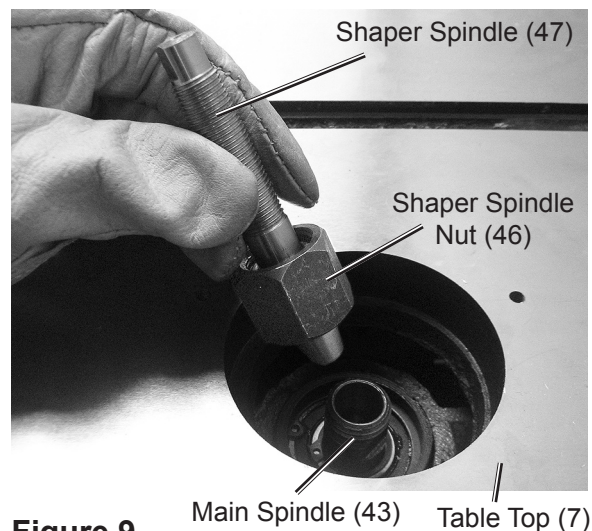

Figure 9

2. Insert the Shaper Nut/Spindle assembly onto the Main Spindle (43). Hand tighten the Nut onto the Main Spindle threads clockwise.

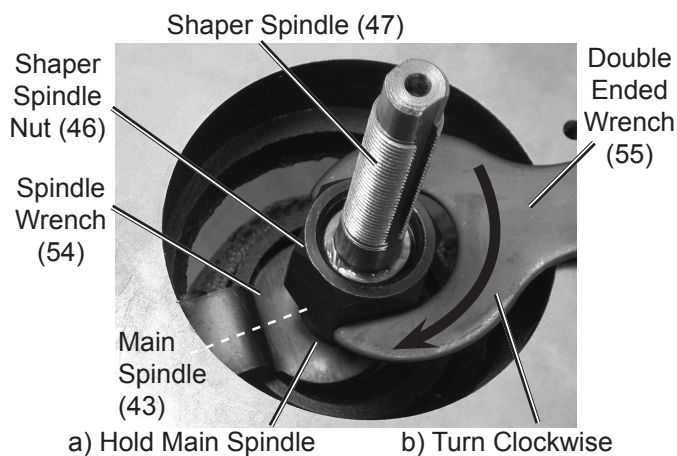

Figure 10

- Use the Double Ended Wrench (55) and Spindle Wrench (54) to tighten the Shaper Spindle (47) in place, turning the Double Ended Wrench clockwise until the Shaper Spindle is secure.

Table Insert

The Table Insert (8) is used to reduce wood chips falling into the machine which could cause flying debris. With router bit use, it also covers any unused portion of the bit below the surface of the Table Top (7).

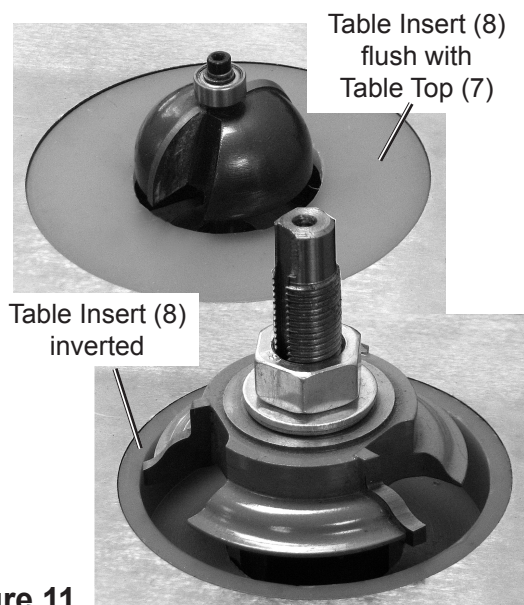

Figure 11

- Always use the Table Insert (8) to prevent materials from falling into the Base (25). Before installing a router bit or a shaper cutter (both sold separately), slide the Table Insert into the Table Top hole until it is flush with the Table Top. There are two ways to position it. If the bit or shaper is entirely above the surface of the table, install the Table Insert with 1-3/8" (smaller) hole facing up. If your bit or shaper is below the surface of the table, the Table Insert should be installed with the larger hole facing up. Spin the bit by hand before plugging in the machine to make sure it will not come into contact with the Table Insert during operation

Installing Shaper Bits

- Install the Shaper Spindle (47) if it is not already installed.
- Insert the Table Insert (8).

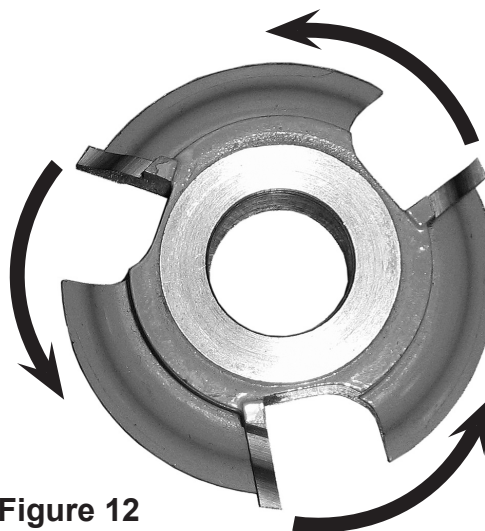

Figure 12

- Position the Cutter or cutters (sold separately) so that the blades are facing in a counter clockwise direction and slide them onto the Shaper Spindle along with any collars as needed for the desired pattern.

- Slide the Washer (13) and the Keyed Washer (48) onto the Shaper Spindle, and thread the Nut onto the end of the Shaper Spindle.

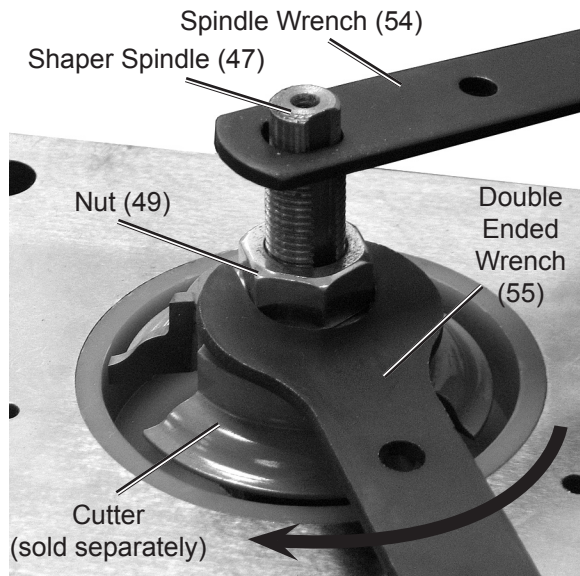

Figure 13

- Use the Spindle Wrench (54) to hold the Shaper Spindle in place while tightening the Nut clockwise with the small end of the Double Ended Wrench (55).

WARNING! The Keyed washer must be directly under the Nut (49) or else serious injury may occur. Be careful to tighten the Nut (49) and the Height Knob (16) securely.

Installing Router Bits

- Remove the Shaper Spindle (47) if it is installed.

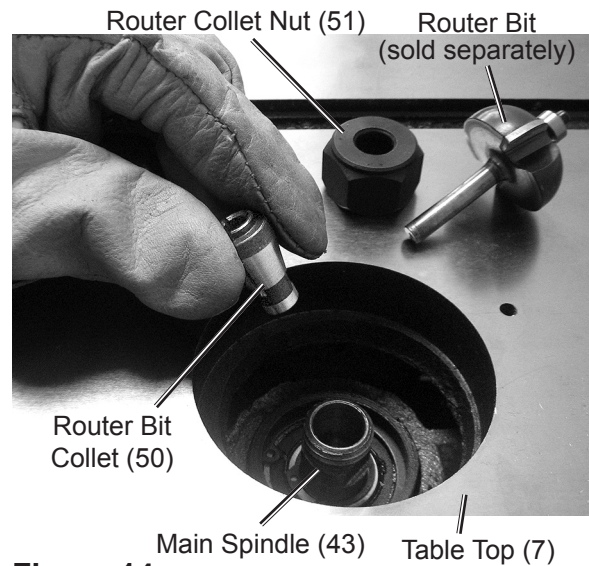

Figure 14

- Insert the Router Bit Collet (50) into the Main Spindle (43).
- Place the Router Collet Nut (51) over the Router Bit Collet and thread it clockwise so that it is loosely in place on the Main Spindle.
- Insert the Table Insert (8).

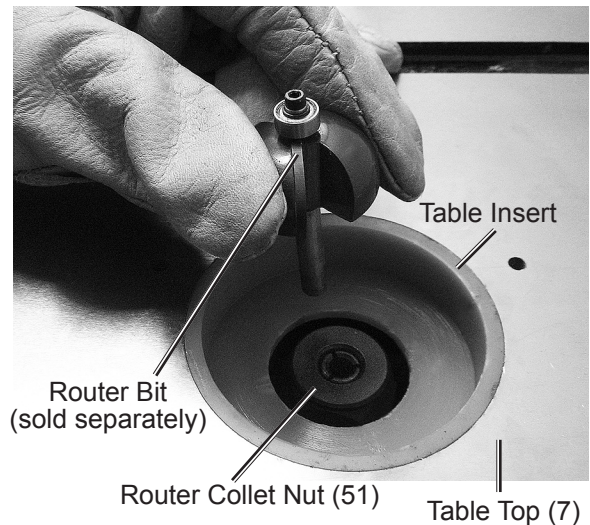

Figure 15

- Insert the router bit (sold separately) into the Main Spindle.
- Firmly tighten the bit in place by turning the Router Collet Nut (51) clockwise with the Double Ended Wrench (55)

while holding the Main Spindle with the Spindle Wrench (54)

Note: With the Table Insert (8) in place, you will need to use both wrenches from below the Table Top (7). You may need to adjust the height of the Main Spindle with the Height Knob (16) to best access the Main Spindle and Router Collet Nut.

Guard and Guide Locations

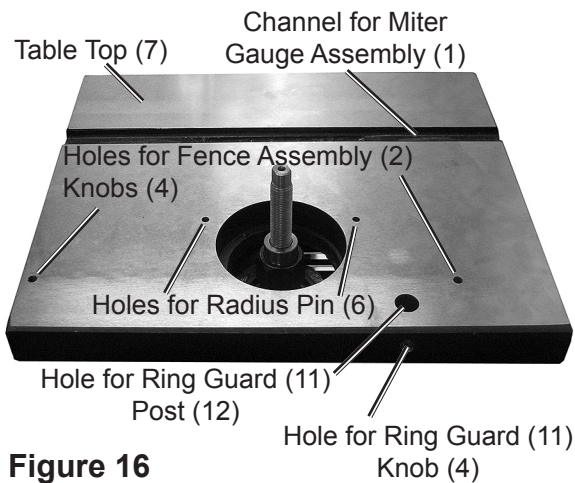

Figure 16

The Fence Assembly (2), Miter Gauge Assembly (1), and Radius Pin (6) are all guides that are attached to the Table Top (7) to help guide the workpiece. Use the Radius Pin or Fence Assembly alone, or use the Fence Assembly with the Miter Gauge to work on mitered workpieces. The Ring Guard (11) is also attached to the Table Top and should always be in place during use.

Fence

1. The Fence Assembly (2) is used for straight edge work. Position the Long Fence (2b) on the Table Top (7) so that the fence slots line up with the holes in the Table Top (7).

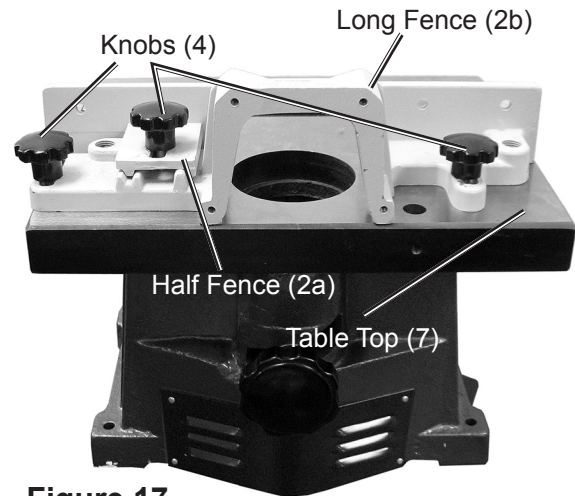

Figure 17

2. Slide a Washer (5) on the Knobs (4), then insert the Knobs (4) into the slots and turn clockwise. Adjust the Fence to the desired position then tighten the Knobs.
3. Place the Half Fence (2a) on the Long Fence as shown above. Adjust the Fence as needed for the project, then secure in place with the Knob (4).

Ring Guard

Always use the Shaper/Router with the Ring Guard (11) in place. It is an important safety feature which protects against contact with the blade. Before plugging in the machine, the Ring Guard should be positioned about 1/4" above the workpiece and then locked into place. When you wish to make adjustments or change cutters, you can loosen the Knob (4) holding the Ring Guard and rotate it out of the way.

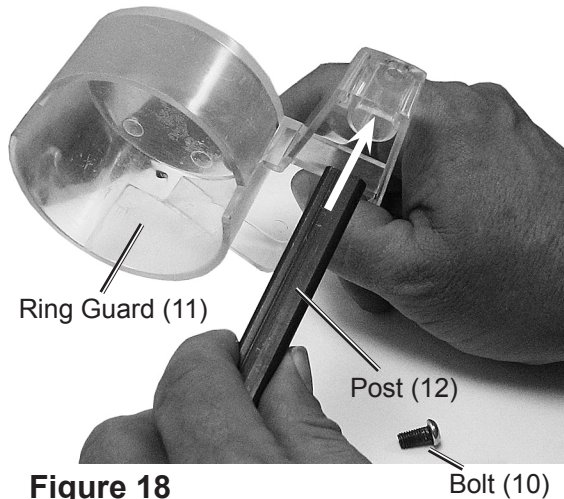

Figure 18

To assemble the Ring Guard, slide the Post (12) into the slot on the Ring Guard and secure in place with the Bolt (10).

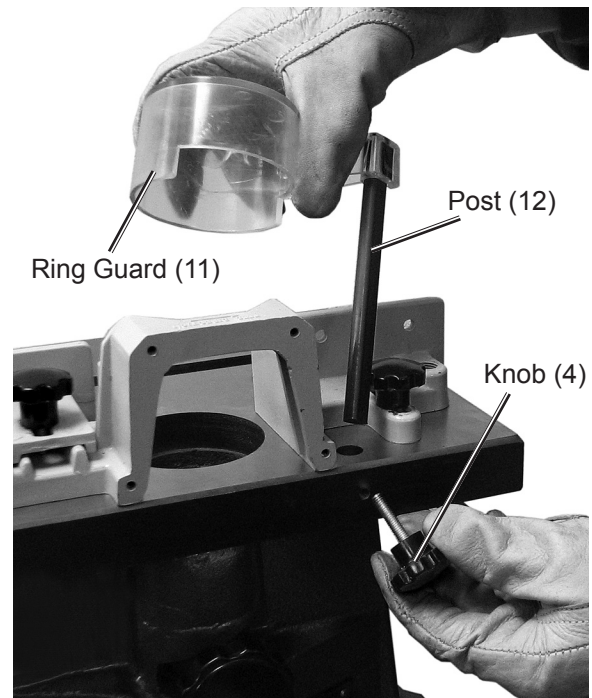

Figure 19

1. To install the Ring Guard, slide the Post into the hole in the Table Top (7).
2. Secure in place with the Knob (4).

Chip Discharge Chute

The Chip Discharge Chute (9) and Adapter (52) direct loose chips away from the work area. The unit can be set up with a bag or vacuum (both sold separately) to gather loose chips from the work area. The use of a vacuum to aid in chip exhaust is recommended. The machine's discharge chute, with the adapter included, will allow you to use a 1-1/2" hose. If discharge chute becomes clogged, turn off power and unplug both machines. Use a pencil or dowel to dislodge chips. If your vacuum is not on, remove hose before starting shaper.

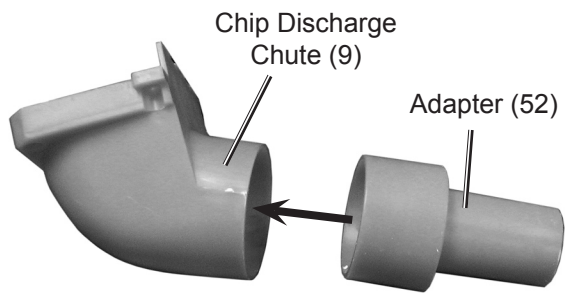

Figure 11

1. To add Adapter, slide it into the Discharge Chute.

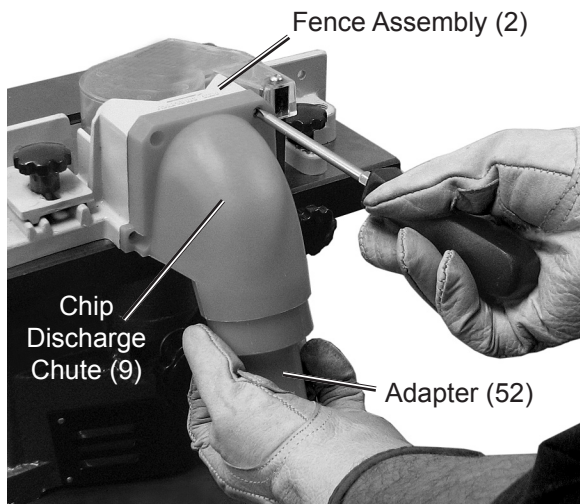

Figure 20

2. Use the four Bolts (10) to secure the Chute onto the Fence Assembly (2). Attache your vacuum to the end of the Chute or Adapter.

Radius Pin

The Radius Pin (6) is used as a guide for freeform work, in place of the Fence Assembly (2).

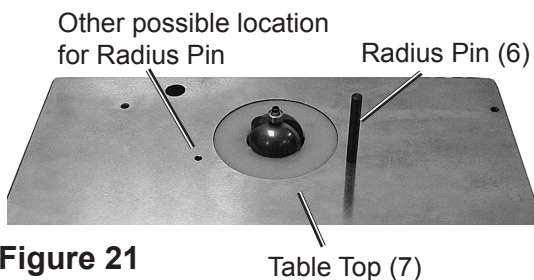

Figure 21

1. To set up the Shaper/Router for freeform projects, remove the Fence Assembly (2)

and thread the Radius Pin (6) clockwise into the hole shown above.

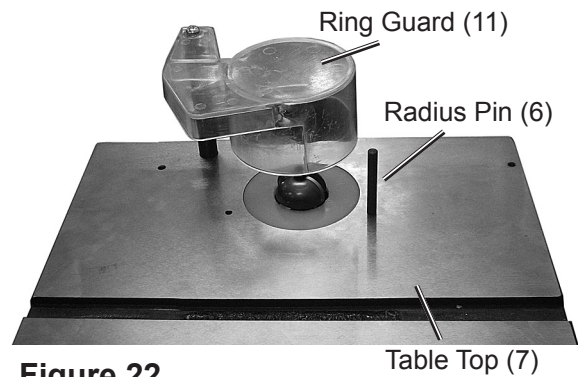

Figure 22

2. Install the Ring Guard.

Miter Gauge

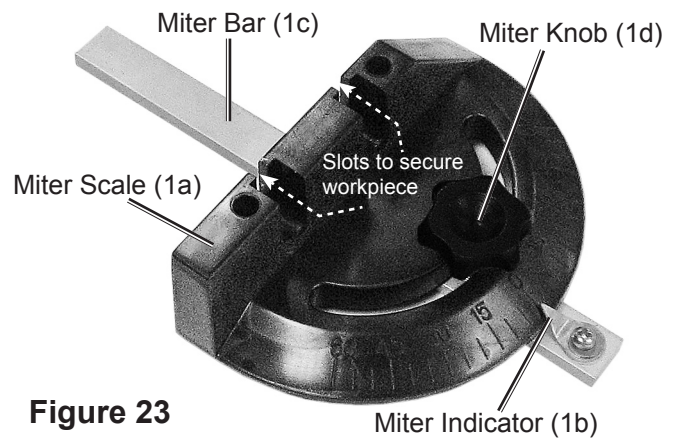

Figure 23

The Miter Gauge Assembly (1) is an adjustable guide that slides along the channel in the Table Top (7) to guide the workpiece into the blade at a specific angle. The unit is adjustable from 0° to ±60°. The workpiece can be secured to the Miter Gauge with pan head screws through the two slots in the face of the gauge.

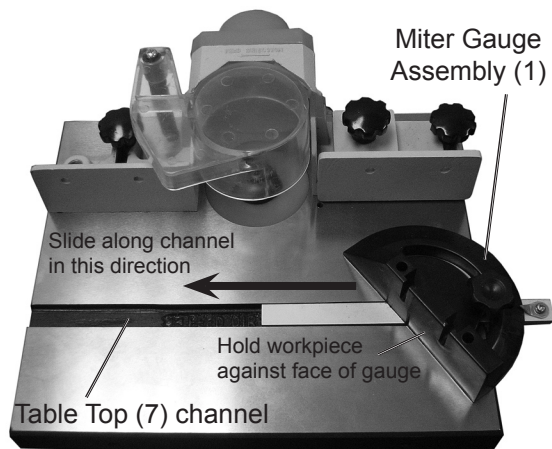

Figure 24

To use the Gauge:

1. Loosen the Miter Knob (1d) counter clockwise and rotate the Miter Scale (1a) so the Miter Indicator (1b) is pointing to the desired degree on the Indicator. Tighten in place with the Miter Knob.
2. Place the Miter Bar (1c) in the channel on the Table Top (7) and hold the work piece against the face of the gauge.
3. Slide the Assembly along the channel to make the cut.

Switch and Key

The ON/OFF Switch (27a) is located on the front of the machine. On is up and off is down. The Switch Key (27b) is a safety feature and must be in the Switch (27a) for the Shaper/Router to function. The Switch Key (27b) can be removed when the switch is in the off position only. Make sure the machine is unplugged before removing the Switch Key.

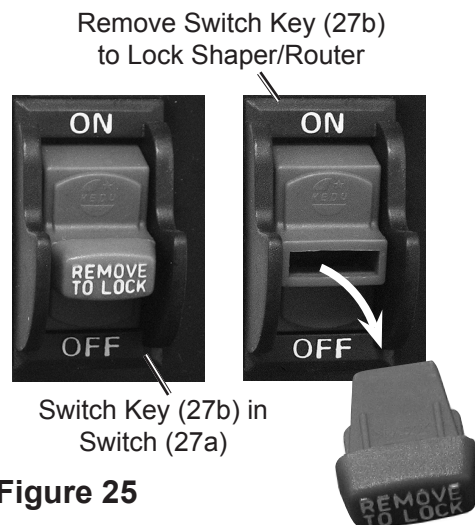

Figure 25

To lock the Shaper/Router when not in use, unplug the Shaper/Router and pull out the Switch Key.

Work Piece and Work Area Set Up

1. Designate a work area that is clean and well-lit. The work area must not allow access by children or pets to prevent distraction and injury.
2. Route the power cord along a safe route to reach the work area without creating a tripping hazard or exposing the power cord to possible damage. The power cord must reach the work area with enough extra length to allow free movement while working.
3. Secure loose work pieces using a vise or clamps (not included) to prevent movement while working.
4. There must not be objects, such as utility lines, nearby that will present a hazard while working.
5. When working with stock that does not receive sufficient support from the machine's table, use a table extension. Fence extensions can also be added the Fence Assembly (2), attaching them through the holes on the Fence faces.

Other means of support are roller stands. All are available from Harbor Freight Tools.

6. A light coat of clear automotive paste wax can be applied on the table top and the fence faces whenever necessary. This will reduce friction and protect wood surfaces.

General Operating Instructions

This Shaper/Router can be used in a variety of ways for different functions. Following are the basic steps needed for using the unit.

1. Prepare the workpiece. Make sure your workpiece is as close to its final size as possible using saws and planers or jointers. Do not make too heavy of a cut when using the Shaper/Router or poor results and dangerous kickback may result.
1. Make sure the Shaper/Router is unplugged and the Switch Key (27b) is removed.
2. Install the shaper cutter or router bit (both sold separately) along with the Table Insert (8). Hand spin the blade to make sure it will not come in contact with the Table Insert.
3. Install the guides needed for your project. Guides you may need include:
 - a. Fence Assembly (2)
 - b. Miter Gauge Assembly (1)
 - c. Radius Pin (6)
 - d. Chip Discharge Chute (9)
4. Install the Ring Guard (11).
5. Set the depth of cut. This is adjusted in several ways. You can move the Fence Assembly (2) or adjust the spindle height, or when shaping, you can use

collars with the cutters to adjust the cutting height.

6. Plug in the machine.
7. Insert the Switch Key (27b) into the Switch, and turn the Switch on.
8. Feed the workpiece into the blade from right to left.

WARNING! Use a push block to feed stock into shapers or bits. Always feed workpiece into blade from right to left.

9. When finished cutting, turn the Switch Off, remove the Switch Key, and unplug the Shaper/Router.

Shaping and Routing Techniques

Following are some techniques that help when shaping or routing. Consult routing and shaping books and internet sources for more thorough information on various techniques.

Wood Grain

Since your machine operates at such high speeds, with most woods it doesn't matter if you cut with or against the grain. With woods such as fir and redwood (open grained woods), cutting against the grain may give splintered, uneven results. When you must cut against the grain with such woods, make several shallow passes; the final and last pass should remove 1/16" material or less.

Across the Grain

Splintering of the back edge will occur when attempting cross-grain cuts. There are two ways to reduce this problem:

- a. Cut the workpiece 1/4" oversize (lengthwise) and trim off excess.
- b. Clamp a piece of scrap to trailing end.

Straight Edge Shaping

Position fence faces so that they are parallel to each other and lock them into place after installing shaper. Position the shaper so that one of the cutting faces is 90° from the fence faces. To get an idea of the profile of the cut, place the workpiece against the infeed fence and slide it against the face of the cutter. Set fence location and adjust spindle height to give the approximate cut profile. Try out the setting on a piece of scrap. Shut off and unplug router when about 2" of test piece is adjacent to the outfeed side of fence. Clamp scrap. Loosen the three knobs holding the fence and segment. Slide both fence faces until they support the workpiece entirely. Tighten all of the knobs and resume test cut.

Irregular And Curved Shaping

Remove fence assembly and replace it with Radius Pin (6) and a collar (sold separately). The Collar can either be of the bell bearing or solid variety and is mounted below or above the shaper cutter on the Shaper Spindle (47) in order to set the depth of cut. There are two methods for shaping irregular and curved edges:

- c. Pattern - This way is best when more than one piece is being cut in the same shape. A template can be cut from 1/4" scrap. Allow for collar diameter, contour shape and depth of cut. Cut workpiece as close as possible to desired final shape. Fasten your template to the workpiece using glue, brads, screws, or clamps. Feed into the cutter until the collar contacts the template. Slowly feed the workpiece around the template, holding the template tight against the collar.

- d. Collar - If at least 1/8" of your edge can remain uncut, this method can be used. As above, cut your workpiece as close as possible to the desired shape. Rest it against the radius pin and feed into cutter until finished edge is against collar. Keep your edge at a 90° angle to the collar. Hold firmly against the collar and slowly feed around the shape until you are done.

MAINTENANCE AND SERVICING



Procedures not specifically explained in this manual must be performed only by a qualified technician.

WARNING

TO PREVENT SERIOUS INJURY

FROM ACCIDENTAL OPERATION:

Turn the Power Switch of the Shaper/Router to its "OFF" position and unplug the tool from its electrical outlet before performing any inspection, maintenance, or cleaning procedures.

TO PREVENT SERIOUS INJURY FROM SHAPER/ROUTER FAILURE:

Do not use damaged equipment. If abnormal noise or vibration occurs, have the problem corrected before further use.

Cleaning, Maintenance, and Lubrication

1. **BEFORE EACH USE**, inspect the general condition of the tool. Check for loose hardware, misalignment or binding of moving parts, cracked or broken parts, damaged electrical wiring, and any other condition that may affect its safe operation.
2. **AFTER USE**, wipe external surfaces of the tool with a clean cloth.
3. **WARNING!** If the supply cord of this power tool is damaged, it must be replaced only by a qualified service technician.

TIMING BELT REPLACEMENT:

1. Turn off machine, unplug and remove the key.
2. Remove guards and guides. Turn unit on it's side or upside down on a suitable, clean work surface.

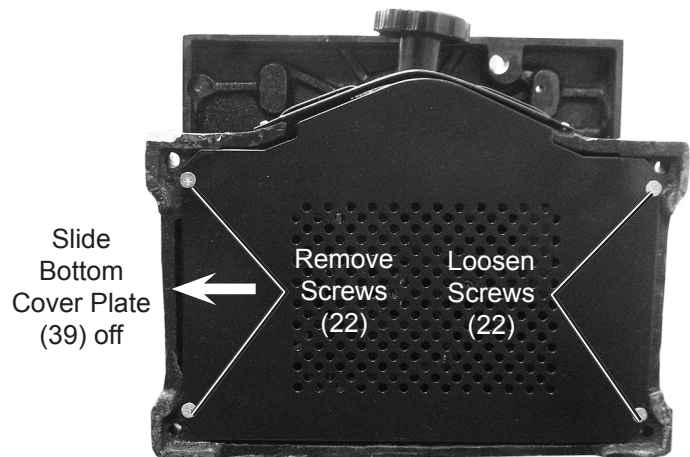

Figure 26

3. Loosen and remove two of the four Screws (22) on the Bottom Cover Plate (39) and slide the Plate off of the unit.

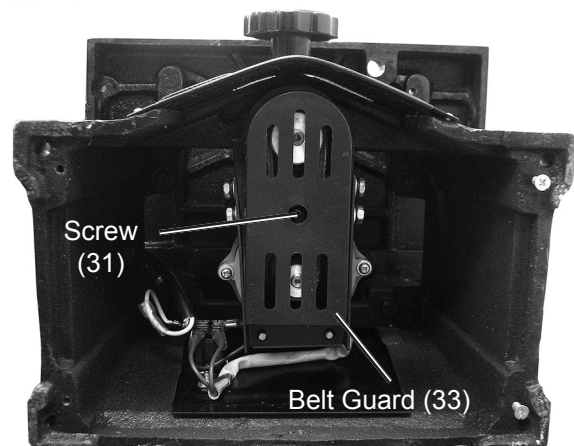

Figure 27

4. Unthread the Screw (31) holding the Belt Guard (33) in place and remove the Belt Guard.

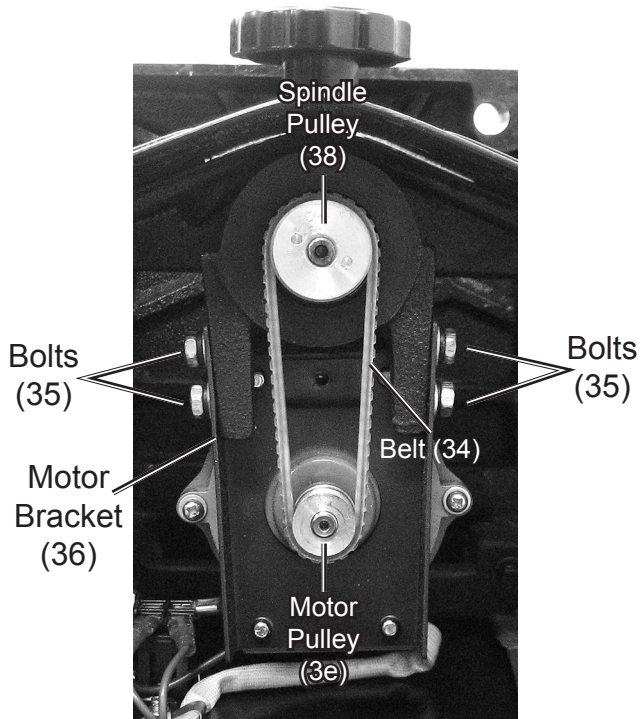

Figure 28

5. Remove the old Belt (34) and place a new belt on the Pulleys (3e and 38).
6. If the tension needs adjusting:
 - a. Loosen the four hex head Bolts (35) on the Motor Bracket (36).
 - b. Slide the bracket up or down until the sides of the belt are tight.
 - c. Tighten the bolts and make sure the belt runs straight.

NOTE: Never over-tension belt as this will result in shortened motor bearing life.

7. Replace the belt guard and turn the machine right side up.

Carbon Brush Replacement

Replacement Carbon Brushes (3b) are included with this unit. The Carbon Brushes should be replaced by a qualified technician.

Troubleshooting

Problem	Possible Causes	Likely Solutions
Tool will not start.	<ol style="list-style-type: none"> 1. Cord not connected. 2. No power at outlet. 3. Internal damage or wear. (Carbon brushes or switch, for example.) 	<ol style="list-style-type: none"> 1. Check that cord is plugged in. 2. Check power at outlet. If outlet is unpowered, turn off tool and check circuit breaker. If breaker is tripped, make sure circuit is right capacity for tool and circuit has no other loads. 3. Have technician service tool.
Tool operates slowly.	Extension cord too long or wire size too small.	Eliminate use of extension cord. If an extension cord is needed, use shorter/heavier gauge cord. See <i>Extension Cords</i> in <i>GROUNDING</i> section.
Performance decreases over time.	<ol style="list-style-type: none"> 1. Accessory dull or damaged. 2. Carbon brushes worn or damaged. 	<ol style="list-style-type: none"> 1. Keep cutting accessories sharp. Replace as needed. 2. Have qualified technician replace brushes.
Excessive noise or rattling.	<ol style="list-style-type: none"> 1. Belt too loose (slipping) or too tight (bearing damage). 2. Internal damage or wear. (Carbon brushes or bearings, for example.) 	<ol style="list-style-type: none"> 1. Properly tension belt. 2. Have technician service tool.
Overheating.	<ol style="list-style-type: none"> 1. Forcing material into blades too fast. 2. Accessory misaligned. 3. Accessory dull or damaged. 4. Blocked motor housing vents. 5. Motor being strained by long or small diameter extension cord. 	<ol style="list-style-type: none"> 1. Allow machine to work at its own rate. 2. Check and correct accessory to fence and/or table alignment. 3. Keep cutting accessories sharp. Replace as needed. 4. Wear ANSI-approved safety goggles and NIOSH-approved dust mask/respirator while blowing dust out of motor using compressed air. 5. Eliminate use of extension cord. If an extension cord is needed, use one with the proper diameter for its length and load. See <i>Extension Cords</i> in <i>GROUNDING</i> section.
 Follow all safety precautions whenever diagnosing or servicing the tool. Disconnect power supply before service.		

PLEASE READ THE FOLLOWING CAREFULLY

THE MANUFACTURER AND/OR DISTRIBUTOR HAS PROVIDED THE PARTS LIST AND ASSEMBLY DIAGRAM IN THIS MANUAL AS A REFERENCE TOOL ONLY. NEITHER THE MANUFACTURER OR DISTRIBUTOR MAKES ANY REPRESENTATION OR WARRANTY OF ANY KIND TO THE BUYER THAT HE OR SHE IS QUALIFIED TO MAKE ANY REPAIRS TO THE PRODUCT, OR THAT HE OR SHE IS QUALIFIED TO REPLACE ANY PARTS OF THE PRODUCT. IN FACT, THE MANUFACTURER AND/OR DISTRIBUTOR EXPRESSLY STATES THAT ALL REPAIRS AND PARTS REPLACEMENTS SHOULD BE UNDERTAKEN BY CERTIFIED AND LICENSED TECHNICIANS, AND NOT BY THE BUYER. THE BUYER ASSUMES ALL RISK AND LIABILITY ARISING OUT OF HIS OR HER REPAIRS TO THE ORIGINAL PRODUCT OR REPLACEMENT PARTS THERETO, OR ARISING OUT OF HIS OR HER INSTALLATION OF REPLACEMENT PARTS THERETO.

Record Product's Serial Number Here: _____

Note: If product has no serial number, record month and year of purchase instead.

Note: Some parts are listed and shown for illustration purposes only, and are not available individually as replacement parts.

REV 10e

SKU 32650

For technical questions, please call 1-800-444-3353.

Page 23

PARTS LIST

Part	Description	Qty
1	Miter Gauge Assembly	1
1a	Miter Scale	1
1b	Miter Indicator	1
1c	Miter Bar	1
1d	Miter Knob	1
2	Fence Assembly	1
2a	Half Fence	1
2b	Long Fence	1
3	Motor Assembly	1
3a	Brush Cover	2
3b	Carbon Brush	2
3c	Motor	1
3d	Screw	1
3e	Motor Pulley	1
4	Knob w/Shaft	4
5	Washer	4
6	Radius Pin	1
7	Table Top	1
8	Table Insert	1
9	Chip Discharge Chute	1
10	#10-24 x 1/2 Pan Head Bolt	6
11	Ring Guard	1
12	Post	1
13	1/2" Washer	1
14	#4 Screw	4
15	Rear Cover	1
16	Height Knob	1
17	Stud	1
18	3/8 Flat Washer	1
19	Bushing	1
20	1/4 Washer	8
21	5/16-18x1/2 Socket Set (screw)	4
22	1/4-20x1 Hex Cap Screw	4
23	Cord Strain Reliever	1
24	Power Cord	1

Part	Description	Qty
25	Base	1
26	Front Cover	1
27	Switch Assembly	1
27a	Switch	1
27b	Switch Key	1
28	#10-24x3/8 Pan Head Bolt	3
29	#10 External Tooth Lock Washer	3
30	1/4x1-1/2 Cap Screw	4
31	#8-32x1/2 Pan Head Screw	5
32	#8 External Tooth Lock Washer	5
33	Belt Guard	1
34	Belt	1
35	1/4 Hex Flange Bolt	4
36	Motor Bracket	1
37	3/16 Cable Clamp	1
38	Spindle Pulley	1
39	Bottom Cover Plate	1
40	Spindle Housing	1
41	Internal Retaining Ring	1
42	Ball Bearing 80104	1
43	Main Spindle	1
44	Ball Bearing80202	1
45	External Retaining Ring	1
46	Shaper Spindle Nut	1
47	1/2"-20 Shaper Spindle	1
48	1/2" Keyed Washer	1
49	#1/2"-20 Nut M12 x 1.25 EFT	1
50	Router Bit Collet	1
51	Router Collet Nut #3/4 - 10	1
52	2-1/2 Male to 1-1/4 Female Adapter	1
53	Collar	1
54	Spindle Wrench	1
55	Double Ended Wrench	1
56	Nut (not shown) - Packing nut for Height Knob Stud	1

ASSEMBLY DIAGRAM

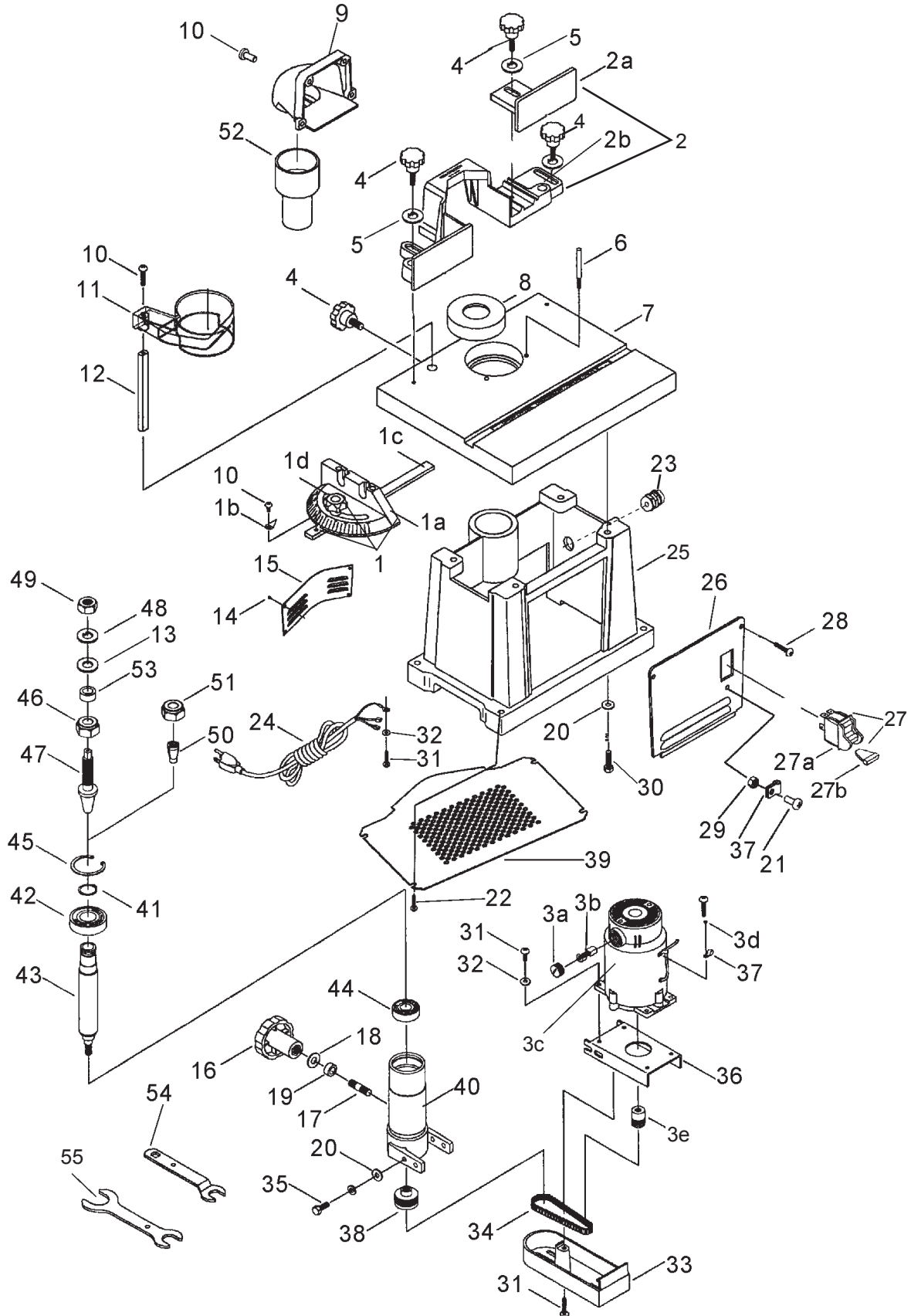

REV 10e

SKU 32650

For technical questions, please call 1-800-444-3353.

Page 25

LIMITED 1 YEAR / 90 DAY WARRANTY

Harbor Freight Tools Co. makes every effort to assure that its products meet high quality and durability standards, and warrants to the original purchaser that for a period of ninety days from date of purchase that the engine/motor, the belts (if so equipped), and the blades (if so equipped) are free of defects in materials and workmanship. Harbor Freight Tools also warrants to the original purchaser, for a period of one year from date of purchase, that all other parts and components of the product are free from defects in materials and workmanship (90 days if used by a professional contractor or if used as rental equipment). This warranty does not apply to damage due directly or indirectly, to misuse, abuse, negligence or accidents, repairs or alterations outside our facilities, normal wear and tear, or to lack of maintenance. We shall in no event be liable for death, injuries to persons or property, or for incidental, contingent, special or consequential damages arising from the use of our product. Some states do not allow the exclusion or limitation of incidental or consequential damages, so the above limitation of exclusion may not apply to you. THIS WARRANTY IS EXPRESSLY IN LIEU OF ALL OTHER WARRANTIES, EXPRESS OR IMPLIED, INCLUDING THE WARRANTIES OF MERCHANTABILITY AND FITNESS.

To take advantage of this warranty, the product or part must be returned to us with transportation charges prepaid. Proof of purchase date and an explanation of the complaint must accompany the merchandise. If our inspection verifies the defect, we will either repair or replace the product at our election or we may elect to refund the purchase price if we cannot readily and quickly provide you with a replacement. We will return repaired products at our expense, but if we determine there is no defect, or that the defect resulted from causes not within the scope of our warranty, then you must bear the cost of returning the product.

This warranty gives you specific legal rights and you may also have other rights which vary from state to state.

3491 Mission Oaks Blvd. • PO Box 6009 Camarillo, CA 93011 • (800) 444-3353

Free Manuals Download Website

<http://myh66.com>

<http://usermanuals.us>

<http://www.somanuals.com>

<http://www.4manuals.cc>

<http://www.manual-lib.com>

<http://www.404manual.com>

<http://www.luxmanual.com>

<http://aubethermostatmanual.com>

Golf course search by state

<http://golfingnear.com>

Email search by domain

<http://emailbydomain.com>

Auto manuals search

<http://auto.somanuals.com>

TV manuals search

<http://tv.somanuals.com>