

# **CEN-TECH®**

## **ELECTRIC PLATFORM SCALE**

### **330 LB. WEIGHT CAPACITY**

### **Model 98982**

### **SET UP AND OPERATING INSTRUCTIONS**



Scale not legal for trade or postage.

Distributed exclusively by Harbor Freight Tools®.

3491 Mission Oaks Blvd., Camarillo, CA 93011

Visit our website at: <http://www.harborfreight.com>



**Read this material before using this product.  
Failure to do so can result in serious injury.  
SAVE THIS MANUAL.**

Copyright© 2008 by Harbor Freight Tools®. All rights reserved. No portion of this manual or any artwork contained herein may be reproduced in any shape or form without the express written consent of Harbor Freight Tools. Diagrams within this manual may not be drawn proportionally. Due to continuing improvements, actual product may differ slightly from the product described herein. Tools required for assembly and service may not be included.

**For technical questions or replacement parts, please call 1-800-444-3353.**

---

## SAVE THIS MANUAL

---

Keep this manual for the safety warnings and precautions, assembly, operating, inspection, maintenance and cleaning procedures. Write the product's serial number in the back of the manual near the assembly diagram (or month and year of purchase if product has no number). Keep this manual and the receipt in a safe and dry place for future reference.

---

## IMPORTANT SAFETY INFORMATION

---

In this manual, on the labeling, and all other information provided with this product:



This is the safety alert symbol. It is used to alert you to potential personal injury hazards. Obey all safety messages that follow this symbol to avoid possible injury or death.

### **DANGER**

**DANGER** indicates a hazardous situation which, if not avoided, will result in death or serious injury.

### **WARNING**

**WARNING** indicates a hazardous situation which, if not avoided, could result in death or serious injury.

### **CAUTION**

**CAUTION**, used with the safety alert symbol, indicates a hazardous situation which, if not avoided, could result in minor or moderate injury.

### **NOTICE**

**NOTICE** is used to address practices not related to personal injury.

### **CAUTION**

**CAUTION**, without the safety alert symbol, is used to address practices not related to personal injury.

---

## General Safety Warnings

---



**WARNING** Read all safety warnings and instructions. *Failure to follow the warnings and instructions may result in electric shock, fire and/or serious injury. Save all warnings and instructions for future reference.*

1. **Work area safety**
  - a. **Keep work area clean and well lit.** *Cluttered or dark areas invite accidents.*
  - b. **Do not operate the Scale in explosive atmospheres, such as in the presence of flammable liquids, gases or dust.** *Line operated and battery operated equipment create sparks which may ignite dust or fumes.*
  - c. **Keep children and bystanders away while operating the Scale.** *Distractions can cause you to lose control.*
2. **Electrical safety**
  - a. **The Power Plug (17) must match the outlet. Never modify the Plug in any way. Do not use any additional adapter plugs with the Scale.** *Unmodified plugs and matching outlets will reduce risk of electric shock.*
  - b. **Avoid body contact with grounded surfaces such as pipes, radiators,**

**ranges and refrigerators.** *There is an increased risk of electric shock if your body is grounded.*

- c. **Do not expose the Scale to rain or wet conditions.** *Water entering the Scale will increase the risk of electric shock.*
  - d. **Do not abuse the Power Cord (17).** *Never use the Cord for carrying, pulling or unplugging the Cord. Keep the Cord away from heat, oil, sharp edges or moving parts. Damaged or entangled Cords increase the risk of electric shock.*
  - e. **When operating the Scale outdoors, use an extension cord suitable for outdoor use.** *Use of a cord suitable for outdoor use reduces the risk of electric shock.*
  - f. **If operating the Scale in a damp location is unavoidable, use a Ground Fault Circuit Interrupter (GFCI) protected supply.** *Use of a GFCI reduces the risk of electric shock.*
3. **Personal safety**
    - a. **Stay alert, watch what you are doing and use common sense when operating the Scale.** *Do not use the Scale while you are tired or under the influence of drugs, alcohol or medication. A moment of inattention while operating the Scale may result in serious personal injury.*
    - b. **Use safety equipment. Always wear eye protection.** *Safety equipment such as ANSI-approved safety impact goggles will reduce personal injuries.*
    - c. **Prevent unintentional starting.** *Ensure the Power Switch (15) is in the off-position before connect-*
  - ing to power source and/or battery pack, picking up or carrying the tool. *Carrying battery operated equipment with your finger on the Power Switch or energizing equipment that have the Power Switch on invites accidents.*
  - d. **Do not overreach. Keep proper footing and balance at all times.** *This enables better control of the Scale in unexpected situations.*
4. **Scale use and care**
    - a. **Do not force the Scale. Use the correct Scale for your application.** *The correct Scale will do the job better and safer at the rate for which it was designed.*
    - b. **Do not use the Scale if the Power Switch (15) does not turn it on and off.** *Any equipment that cannot be controlled with the Power Switch is dangerous and must be repaired.*
    - c. **Unplug the Power Cord (17) before making any adjustments, changing accessories, or storing the Scale.** *Such preventive safety measures reduce the risk of starting the equipment accidentally.*
    - d. **Store idle equipment out of the reach of children and do not allow persons unfamiliar with the Scale or these instructions to operate the equipment.** *Line powered and battery powered equipment are dangerous in the hands of untrained users.*
    - e. **Maintain the Scale. Check for misalignment or binding of moving parts, breakage of parts and any other condition that may affect the Scale's operation.** *If damaged, have the Scale repaired before*

**use.** *Many accidents are caused by poorly maintained equipment.*

- f. **Use the Scale in accordance with these instructions, taking into account the working conditions and the work to be performed.** *Use of the Scale for operations different from those intended could result in a hazardous situation.*
  5. **Battery tool use and care**
    - a. **Use this Scale only with specifically designated Batteries.** *Use of any other Battery may create a risk of injury and fire.*
    - b. **Under abusive conditions, liquid may be ejected from the Battery (16). Avoid contact. If contact accidentally occurs, flush with water. If liquid contacts eyes, additionally seek medical help.** *Liquid ejected from the Battery may cause irritation or burns.*
  6. **Service**
    - a. **Have your Scale serviced by a qualified repair person using only identical replacement parts.** *This will ensure that the safety of the equipment is maintained.*
3. Do not exceed the Scale's maximum weight capacity of 330 pounds.
  4. Use in a dry location only. Risk of electric shock.
  5. Use on a level, solid surface capable of supporting the weight of the Scale and its load.
  6. Do not lean load against display.
  7. Level the Scale before use.
  8. Wear ANSI-approved safety goggles during assembly and Battery (18) replacement.
  9. **This Scale is not legal for trade or postage.**
  10. Read this manual before set up and use of the Scale.
  11. Do not sit or stand on the Scale.
  12. Avoid unintentional starting. Prepare to begin work before turning on the Scale.
  13. Do not leave the Scale unattended when it's Power Cord (17) is plugged into an electrical outlet. Turn off the equipment, and unplug the Power Cord from its electrical outlet before leaving.
  14. This product is not a toy. Keep it out of reach of children.
  15. People with pacemakers should consult their physician(s) before use. Electromagnetic fields in close proximity to heart pacemaker could cause pacemaker interference or pacemaker failure. In addition, people with pacemakers should:
    - Avoid operating alone.
    - Do not use with power switch locked

### **Specific Safety Warnings**

1. Maintain labels and nameplates on the Scale. These carry important safety information. If unreadable or missing, contact Harbor Freight Tools for a replacement.
2. This Scale contains a sealed lead Battery (16). Do not dispose of an old Battery in fire to avoid explosion and possible personal injury. Recycle old batteries according to local solid waste authority procedures.

on.

- Properly maintain and inspect to avoid electrical shock.
- Any power cord must be properly grounded. Ground Fault Circuit Interrupter (GFCI) should also be implemented – it prevents sustained electrical shock.

16. CONTAINS SEALED LEAD BATTERY. BATTERY MUST BE RECYCLED.
17. WARNING: Handling the cord on this product will expose you to lead, a chemical known to the State of California to cause cancer, and birth defects or other reproductive harm. Wash hands after handling. (California Health & Safety Code § 25249.5, *et seq.*)
18. WARNING: This product contains lead, which is a chemical known to the State of California to cause cancer and birth defects or other reproductive harm. (California Health & Safety Code § 25249.5, *et seq.*)
19. The warnings, precautions, and instructions discussed in this instruction manual cannot cover all possible conditions and situations that may occur. It must be understood by the operator that common sense and caution are factors which cannot be built into this product, but must be supplied by the operator.

 **SAVE THESE INSTRUCTIONS.**

---

## GROUNDING

---

### **WARNING TO PREVENT ELECTRIC SHOCK**



#### **AND DEATH FROM INCORRECT GROUNDING WIRE CONNECTION:**

**Check with a qualified electrician if you are in doubt as to whether the outlet is properly grounded. Do not modify the Power Cord Plug provided with the Scale. Never remove the grounding prong from the Plug. Do not use the if the Power Cord or Plug is damaged. If damaged, have it repaired by a service facility before use. If the Plug will not fit the outlet, have a proper outlet installed by a qualified electrician.**

---

### **Grounded Tools: Tools with Three Prong Plugs**

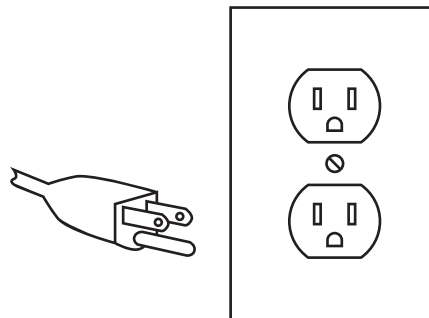

**3-Prong Plug and Outlet**

1. Equipment marked with “Grounding Required” have a three wire cord and three prong grounding Plug. The Plug must be connected to a properly grounded outlet. If the equipment should electrically malfunction or break down, grounding provides a low resistance path to carry electricity away from the user, reducing the risk

- of electric shock.  
**(See 3-Prong Plug and Outlet.)**
- The grounding prong in the Plug is connected through the green wire inside the Cord to the grounding system in the equipment. The green wire in the Cord must be the only wire connected to the equipment's grounding system and must never be attached to an electrically "live" terminal.  
**(See 3-Prong Plug and Outlet.)**
  - The equipment must be plugged into an appropriate outlet, properly installed and grounded in accordance with all codes and ordinances. The Plug and outlet should look like those in the preceding illustration.  
**(See 3-Prong Plug and Outlet.)**

### Extension Cords



- Grounded* equipment require a three wire extension cord. **Double Insulated** equipment can use either a two or three wire extension cord.
- As the distance from the supply outlet increases, you must use a heavier gauge extension cord. Using extension cords with inadequately sized wire causes a serious drop in voltage, resulting in loss of power and possible tool damage.  
The smaller the gauge number of the wire, the greater the capacity of the cord. For example, a 14 gauge cord can carry a higher current than a 16 gauge cord. **(See Table A.)**
- When using more than one extension cord to make up the total length, make sure each cord contains at least the minimum wire size required.  
**(See Table A.)**

- If you are using one extension cord for more than one tool, add the nameplate amperes and use the sum to determine the required minimum cord size. **(See Table A.)**
- If you are using an extension cord outdoors, make sure it is marked with the suffix "W-A" ("W" in Canada) to indicate it is acceptable for outdoor use.
- Make sure the extension cord is properly wired and in good electrical condition. Always replace a damaged extension cord or have it repaired by a qualified electrician before using it.
- Protect the extension cords from sharp objects, excessive heat, and damp or wet areas.



RECOMMENDED MINIMUM WIRE GAUGE FOR EXTENSION CORDS* (110/220 VOLT)					
NAMEPLATE AMPERES (at full load)	EXTENSION CORD LENGTH				
	25'	50'	75'	100'	150'
0 – 2.0	18	18	18	18	16
2.1 – 3.4	18	18	18	16	14
3.5 – 5.0	18	18	16	14	12
5.1 – 7.0	18	16	14	12	12
7.1 – 12.0	18	14	12	10	-
12.1 – 16.0	14	12	10	-	-
16.1 – 20.0	12	10	-	-	-

**TABLE A** \* Based on limiting the line voltage drop to five volts at 150% of the rated amperes.

### Symbology

	Double Insulated
	Canadian Standards Association

## Symbology

	Underwriters Laboratories, Inc.
	Volts Alternating Current
	Amperes
$n_0$ xxxx/min.	No Load Revolutions per Minute (RPM)

## SPECIFICATIONS

Electrical Requirements	Input: 110 VAC~ / 60 Hz Battery Type: 6 VDC Sealed Lead Acid Power Switch: ON/Off Rocker Switch Power Plug: 3-Prong, Grounded
Maximum Weight Capacity	330 Pounds (150 kilograms)
Main Functions	Auto Turn Off When Under Voltage Count Limit Set Auto Zero Track Keyboard Calibration Overload Alarm
Control Panel Button Indicators	ADD, C, HOLD, FUNC, ZERO/TARE, UNIT
Additional Features	Four Adjustable Feet & Level Indicator for Leveling of Scale. Built-In Rechargeable Battery.

## UNPACKING

When unpacking, check to make sure that the item is intact and undamaged. If any parts are missing or broken, please call Harbor Freight Tools at the number shown on the cover of this manual as soon as possible.

## OPERATING INSTRUCTIONS



**Read the ENTIRE IMPORTANT SAFETY INFORMATION section at the beginning of this manual including all text under**

subheadings therein before set up or use of this product.

### **⚠️ WARNING TO PREVENT SERIOUS INJURY**

**FROM ACCIDENTAL OPERATION:**

**Turn the Power Switch (15) to its off position and unplug the Power Cord (17) before performing any inspection, maintenance, or cleaning procedures.**

## Assembly Instructions

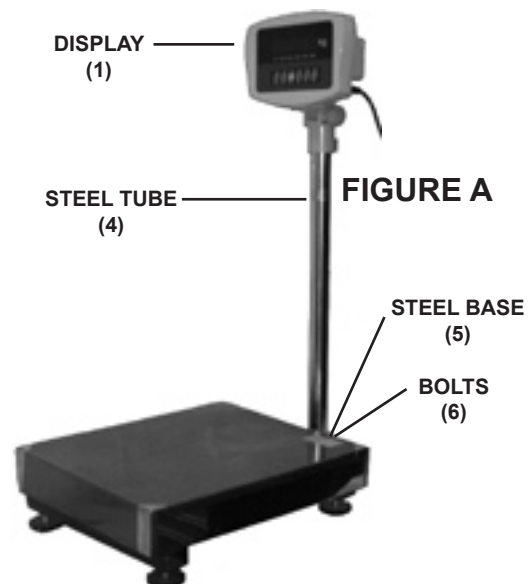

Attach the Display (1) and Steel Tube (4) to the Steel Base (5) of the Scale using four Bolts (6). **(See Figure A.)**

## Scale Set Up

1. Place the Scale on a clean, dry, flat, level surface capable of supporting the weight of the Scale and all objects to be weighed.
2. The work area must be free of vibration, strong air currents, direct sunshine, and high temperature.

- Designate a work area that is well-lit. The area must not allow access by children or pets to prevent injury and distraction.

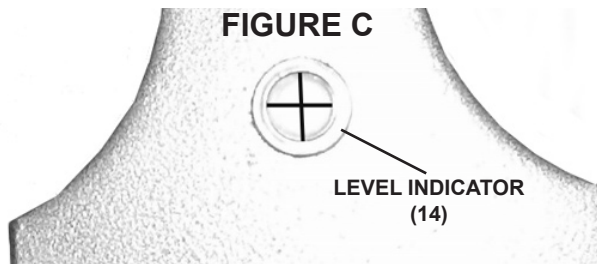
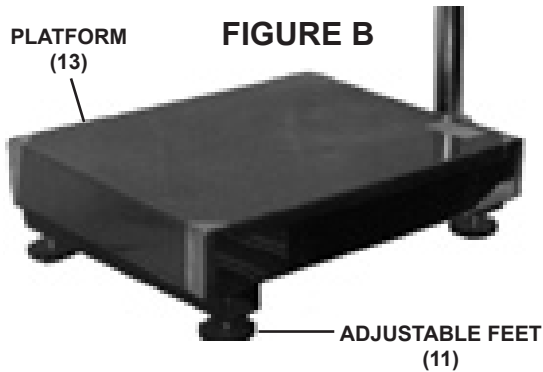

- The four Adjustable Feet (11) and Level Indicator (14) of the Scale are used for leveling the unit. Use the Adjustable Feet and Level Indicator to level the Scale accordingly. **(See Figures B and C.)**
- Make sure the *sides* of the Scale's Platform (13) do not come in contact with any object prior to setting an object on the Platform to be weighed. **(See Figure B.)**
- Route the Power Cord (17) along a safe route to reach the work area without creating a tripping hazard or exposing the Cord to possible damage.

## General Operating Instructions

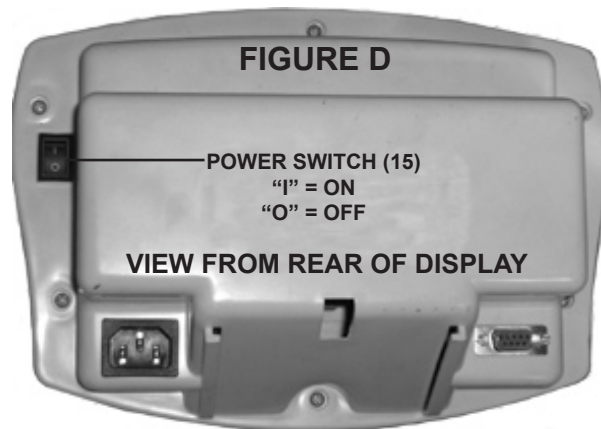

- Plug the Power Cord/Plug (17) into the nearest 110 volt, grounded, electrical outlet. Then turn the Power Switch to its "ON" position. **IMPORTANT:** Make sure there is no load on the Scale when turning the Power Switch on. **(See Figure D.)**
- For best accuracy, allow the Scale to warm up for ten minutes before applying weight.
- When turned on, the Scale will self-check the rechargeable Battery (16) and display "dc x.xxx". If necessary, the Scale will automatically enter the Battery into a charging mode.
  - When using the Battery (16) to power the Scale, and the Battery voltage is lower than 5.4V, the Scale will turn off automatically. In this event, plug the Power Cord/Plug into the nearest 110 volt, grounded, electrical outlet and allow the Battery to charge for at least 8 hours for full capacity.
- After the self-check, the Scale should automatically set itself at the zero position. However, the Scale *did not* locate the zero position if either of the following occurs:



- Displaying “HHHHHH” and emitting an alarm sound, meaning the zero position is too high.
- Displaying “LLLLLL” and emitting an alarm sound, meaning the zero position is too low.

Should either of the above events occur, make sure to check for proper line voltage and Battery voltage. Check that the Scale is level, it has no load, and that its Platform (13) is not touching any other object(s).

**FIGURE E**



### Zero/Tare

1. Press the “ZERO/TARE” button the scale is empty ( $\leq 4\%$  F.S.<sup>1</sup>) and the scale will read zero at the current weight. The zero indicator will also show. **(See Figure E.)**
2. Press “ZERO/TARE” when the weight is positive ( $> 4\%$  F.S.) and the tare indicator will show. The scale will then read based on the tare weight.
3. Remove all weight and press the “ZERO/TARE” button again to exit tare mode.

<sup>1</sup> Full Scale. The full capacity of the scale. For this item, 330 lb. (150 kg).

### Unit:

Press “UNIT” to choose the unit: Lb. or Kg. **(See Figure E.)**

### Hold:

1. Press “HOLD” at any time when weighing. The displayed value will be locked and will not change with weight. Meanwhile, the “HOLD” indicator will show. **(See Figure E)**
2. Press “HOLD” again to exit the hold mode.

**Note:** Under the hold mode, the Scale will sound an alarm when overloaded although the displayed value does not change.

### Memory Functions:

1. With a stable weight on the scale, press “ADD” to add the displayed weight to the unit’s memory. **(See Figure E.)** The M+ indicator will show and the display will flash {ADD= \_\_} with the \_\_ being the number of weights in memory and then read the total accumulated weight from memory.

**Note:** The unit will beep twice if the value is not added (for example if the weight does not remain constant enough.)

2. Press “C” and the cumulative total will be cleared.

### Settings

1. To adjust the backlight brightness, press “FUNC” once and {BAC=0\_\_} will be displayed. The blank is the brightness of the display backlight.

2. Press "ZERO/TARE" to change the brightness. The maximum is 5.
3. Press "FUNC" after selecting the brightness to switch to the manual tare setting mode.
4. The screen will briefly display PStAtE and then display 0000.00 Enter the tare weight in kg using the "UNIT" button to select the digit and the "ZERO/TARE" button to change the digit. Once the tare is selected, press the "ADD" button to return to normal weighing mode.

### Calibration:

**Note:** Calibration is a precise procedure. If done improperly, it can cause the scale to become inaccurate. If you are not comfortable doing the calibration yourself, a qualified technician should calibrate the scale.

1. Turn the scale off. Calibration must be started when first turning on the scale.
2. Connect the scale to an 120 V~ receptacle and remove all weight from the scale.
3. Turn on the Scale. Quickly press "ZERO/TARE", "UNIT", then "ZERO/TARE" after the scale displays 012345, but before the scale is ready to weigh. The scale will enter calibration mode and display the original maximum capacity value and the division. **These are factory settings and should not be altered. Press "ADD" to continue.**
4. The display will now read "-CAL-" first, then "0150.00". Now input the

calibration weight, in kg. Leave the platform empty.

5. Press "UNIT" to select the digit you wish to alter. The selected digit flashes. Press "ZERO/TARE" to change the desired digit. Press "ADD" to finish entering the calibration weight.
6. Wait for the Indicator to display "0.00", this may require a minute or two. Then, put the calibration weight on the Platform.
7. If the value is the same as the calibration weight, press "HOLD". If not, press "ZERO/TARE", then "HOLD" to exit calibration mode, turn off scale and retry calibration.

### Error Information:

1. "**Ad\_Err**" = Can not receive the weight signal from the Sensor (8).
2. "**-----**" = Zero position is too high or the value is too high.
3. "**\_\_\_**" = Zero position is too low or the value is too low.
4. "**Lo\_bat**" = The battery voltage is too low.
5. "**---OL---**" = Overload.
6. "**SEtErr ----**" = The data is not correct.

---

## MAINTENANCE AND SERVICING

---



Procedures not specifically explained in this manual must be performed only by a qualified technician.

### **⚠️ WARNING**

#### **TO PREVENT SERIOUS INJURY**

#### **FROM ACCIDENTAL OPERATION:**

Turn the Power Switch (15) of the Scale to its “OFF” position and unplug the unit’s Power Cord (17) from its electrical outlet before performing any inspection, maintenance, or cleaning procedures.

#### **TO PREVENT SERIOUS INJURY FROM EQUIPMENT FAILURE:**

Do not use damaged equipment. If abnormal noise or vibration occurs, have the problem corrected before further use.

1. BEFORE EACH USE: Inspect the general condition of the Scale. Check for loose screws, misalignment or binding of moving parts, cracked or broken parts, Battery leakage, and any other condition that may affect its safe operation.
2. BATTERY REPLACEMENT: A Battery that fails to accept a charge is an indication the Battery should be replaced. To replace the Battery:

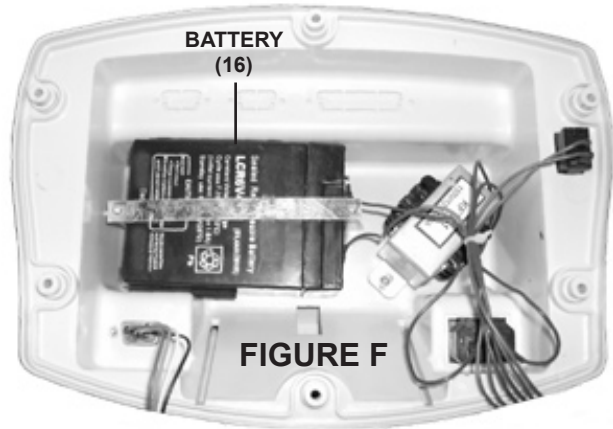

- Unscrew and remove the six Screws (18) located on the back panel of the Display (1). (See Figure F.)
  - Remove the front portion of the Display (1) to expose the Battery (16). (See Figure F.)
  - Remove the old Battery (16) and replace with a new Battery of the same type. Then, re-attach the front portion of the Display (1) to the back portion of the Display and secure using the six Screws (18). (See Figure F.)
  - IMPORTANT: The old Battery (16) must be recycled according to local solid waste authority instructions.
3. AFTER USE: Clean all external surfaces of the Scale with soft, clean cloth. Do not use solvents. Do not immerse the Scale in liquid.
  4. **⚠️ WARNING! If the Power Cord (17) is damaged, it must be replaced only by a qualified service technician.**

## PARTS LIST & ASSEMBLY DIAGRAM

Part #	Description	Qty.	Part #	Description	Qty.
1	Display	1	10	Lower Stand	1
2	Nut	1	11	Adjustable Foot	4
3	Bolt	1	12	Bolt	4
4	Steel Tube	1	13	Platform	1
5	Steel Base	1	14	Level Indicator	1
6	Bolt	4	15	Power Switch	1
7	Upper Stand	1	16	Battery	1
8	Sensor	1	17	Power Cord/Plug	1
9	Bolt	8	18	Screw	6

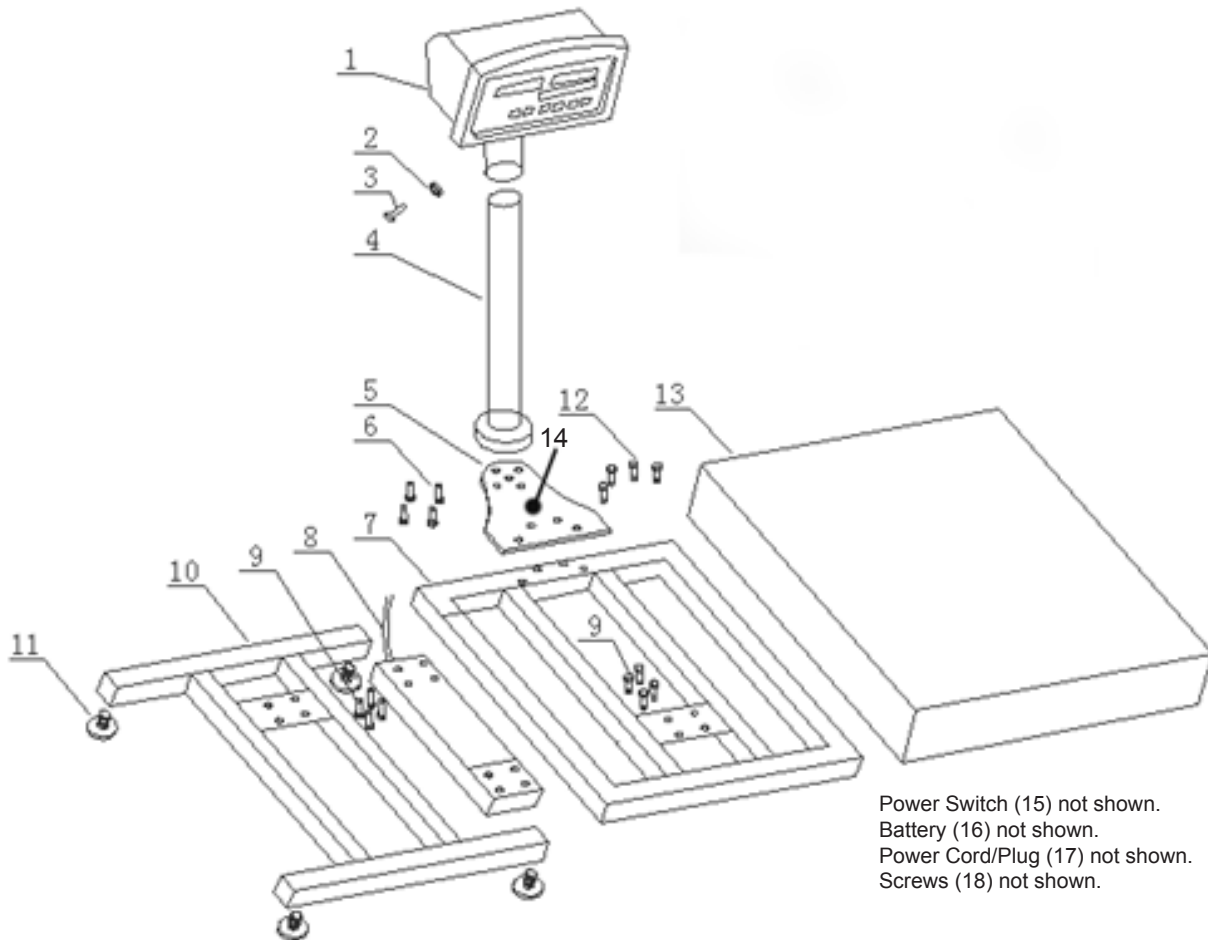

---

## LIMITED 90 DAY WARRANTY

---

Harbor Freight Tools Co. makes every effort to assure that its products meet high quality and durability standards, and warrants to the original purchaser that this product is free from defects in materials and workmanship for the period of 90 days from the date of purchase. This warranty does not apply to damage due directly or indirectly, to misuse, abuse, negligence or accidents, repairs or alterations outside our facilities, criminal activity, improper installation, normal wear and tear, or to lack of maintenance. We shall in no event be liable for death, injuries to persons or property, or for incidental, contingent, special or consequential damages arising from the use of our product. Some states do not allow the exclusion or limitation of incidental or consequential damages, so the above limitation of exclusion may not apply to you. THIS WARRANTY IS EXPRESSLY IN LIEU OF ALL OTHER WARRANTIES, EXPRESS OR IMPLIED, INCLUDING THE WARRANTIES OF MERCHANTABILITY AND FITNESS.

To take advantage of this warranty, the product or part must be returned to us with transportation charges prepaid. Proof of purchase date and an explanation of the complaint must accompany the merchandise. If our inspection verifies the defect, we will either repair or replace the product at our election or we may elect to refund the purchase price if we cannot readily and quickly provide you with a replacement. We will return repaired products at our expense, but if we determine there is no defect, or that the defect resulted from causes not within the scope of our warranty, then you must bear the cost of returning the product.

This warranty gives you specific legal rights and you may also have other rights which vary from state to state.

**3491 Mission Oaks Blvd. • PO Box 6009 • Camarillo, CA 93011 • (800) 444-3353**

**Record Product's Serial Number Here:** \_\_\_\_\_

**Note:** If product has no serial number, record month and year of purchase instead.

**Note:** Some parts are listed and shown for illustration purposes only, and are not available individually as replacement parts.

---

## PLEASE READ THE FOLLOWING CAREFULLY

---

THE MANUFACTURER AND/OR DISTRIBUTOR HAS PROVIDED THE PARTS LIST AND ASSEMBLY DIAGRAM IN THIS MANUAL AS A REFERENCE TOOL ONLY. NEITHER THE MANUFACTURER OR DISTRIBUTOR MAKES ANY REPRESENTATION OR WARRANTY OF ANY KIND TO THE BUYER THAT HE OR SHE IS QUALIFIED TO MAKE ANY REPAIRS TO THE PRODUCT, OR THAT HE OR SHE IS QUALIFIED TO REPLACE ANY PARTS OF THE PRODUCT. IN FACT, THE MANUFACTURER AND/OR DISTRIBUTOR EXPRESSLY STATES THAT ALL REPAIRS AND PARTS REPLACEMENTS SHOULD BE UNDERTAKEN BY CERTIFIED AND LICENSED TECHNICIANS, AND NOT BY THE BUYER. THE BUYER ASSUMES ALL RISK AND LIABILITY ARISING OUT OF HIS OR HER REPAIRS TO THE ORIGINAL PRODUCT OR REPLACEMENT PARTS THERETO, OR ARISING OUT OF HIS OR HER INSTALLATION OF REPLACEMENT PARTS THERETO.

## Free Manuals Download Website

<http://myh66.com>

<http://usermanuals.us>

<http://www.somanuals.com>

<http://www.4manuals.cc>

<http://www.manual-lib.com>

<http://www.404manual.com>

<http://www.luxmanual.com>

<http://aubethermostatmanual.com>

Golf course search by state

<http://golfingnear.com>

Email search by domain

<http://emailbydomain.com>

Auto manuals search

<http://auto.somanuals.com>

TV manuals search

<http://tv.somanuals.com>