

CENTRAL MACHINERY®

2 GALLON COOLANT PUMP

Model 45333

ASSEMBLY AND OPERATING INSTRUCTIONS



3491 Mission Oaks Blvd., Camarillo, CA 93011

Visit our Web site at <http://www.harborfreight.com>

Copyright © 2001 by Harbor Freight Tools. All rights reserved. No portion of this manual or any artwork contained herein may be reproduced in any shape or form without the express written consent of Harbor Freight Tools.

For technical questions and replacement parts, please call 1-800-444-3353

Revised Cover Page 09/04

Download from [Www.Somanuals.com](http://www.Somanuals.com). All Manuals Search And Download.

Specifications

Capacity	2 Gallons
Electrical	110V, 60 Hz, .4 amps
GPM	15
Filter ID	3-1/8"
Filter Hose Length	8 Feet
Features magnetic Flex Hose Base.	

Save This Manual

You will need the manual for the safety warnings and precautions, assembly instructions, operating and maintenance procedures, parts list and diagram. Keep your invoice with this manual. Write the invoice number on the inside of the front cover. Keep the manual and invoice in a safe and dry place for future reference.

Safety Warnings and Precautions

WARNING: When using tool, basic safety precautions should always be followed to reduce the risk of personal injury and damage to equipment.

Read all instructions before using this product!

1. **Avoid working alone.** If an accident happens, an assistant can bring help.
2. **Avoid electrical shock.** Prevent body contact with grounded surfaces such as pipes, radiators, ranges, and cabinet enclosures when testing voltages.
3. **Keep work area clean.** Cluttered areas invite injuries.
4. **Observe work area conditions.** Don't expose to rain. Keep work area well lighted.
5. **Keep children away.** Children must never be allowed in the work area. Do not let them handle machines, tools, or extension cords.
6. **Store idle equipment.** When not in use, tools must be stored in a dry location to inhibit rust. Always lock up tools and keep out of reach of children.
7. **Dress properly.** Do not wear loose clothing or jewelry as they can be caught in moving parts. Protective, electrically nonconductive clothes and nonskid footwear are recommended when working. Wear restrictive hair covering to contain long hair.

8. **Use eye and ear protection.** Always wear ANSI approved impact safety goggles.
9. **Do not overreach.** Keep proper footing and balance at all times. Do not reach over or across electrical cables or frames.
10. **Maintain tools with care.** Inspect tool cords periodically and, if damaged, have them repaired by an authorized technician.
11. **Use the right tool for the job.** Do not attempt to force a small Coolant Pump or attachment to do the work of a larger industrial Coolant Pump. There are certain applications for which this product was designed. Do not modify this Coolant Pump and do not use this tool for a purpose for which it was not intended.
12. **Stay alert.** Watch what you are doing, use common sense. Do not operate any Coolant Pump when you are tired.
13. **Check for damaged parts.** Before using any Coolant Pump, any part that appears damaged should be carefully checked to determine that it will operate properly and perform its intended function. Check for alignment and binding of moving parts; any broken parts or mounting fixtures; and any other condition that may affect proper operation. Any part that is damaged should be properly repaired or replaced by a qualified technician. Do not use the tool if lever does not turn On and Off properly.
14. **Replacement parts and accessories.** When servicing, use only identical replacement parts. Use of any other parts will void the warranty. Only use accessories intended for use with this Coolant Pump. Approved accessories are available from Harbor Freight Tools.
15. **Do not operate Coolant Pump if under the influence of alcohol or drugs.** Read warning labels on prescriptions to determine if your judgment or reflexes are impaired while taking drugs. If there is any doubt, do not operate the Coolant Pump.
16. **Use proper size and type extension cord.** If an extension cord is required, it must be of the proper size and type to supply the correct current to the tool without heating up. Otherwise, the extension cord could melt and catch fire, or cause electrical damage to the tool. This tool requires use of an extension cord of **0 to 10 amps** capability (up to 50 feet), with wire size rated at **18 AWG**. Longer extension cords require larger size wire. If you are using the tool outdoors, use an extension cord rated for outdoor use. (signified by "WA" on the jacket).
17. **Maintenance.** For your safety, maintenance should be performed regularly by a qualified technician.

Note: Performance of this tool (if powered by line voltage) may vary depending on variations in local line voltage. Extension cord usage may also affect tool performance.

Warning: The warnings, cautions, and instructions discussed in this instruction manual cannot cover all possible conditions and situations that may occur. It must be understood by the operator that common sense and caution are factors which cannot be built into this product, but must be supplied by the operator.

Unpacking

When unpacking, check to make sure parts listed on page 5 are included. If any parts are missing or broken, please call Harbor Freight Tools at the number on the cover of this manual.

Assembly

Refer to the Assembly Drawing on page 6.

1. Unsnap both of the **Snap Rings (#9)** and remove the **Cover (#2)**.
2. Insert the **Pump (#3)** through the hole in the **Cover (#2)** making sure the gasket is centered on the brim of the **Pump (#3)** and snug between the **Pump (#3)** and the top of the **Cover (#2)**. Put the matching metal brim (provided) on the bottom of the **Pump (#3)** and snug it up to the bottom of the **Cover (#2)**. Line up the holes of the brim of the **Pump (#3)**, the **Cover (#2)**, the gasket, and provided metal brim. Secure through the top with 3 **Pan Screws (#4)** and **Hex Nuts (#5)**.
3. Connect the **Hose (#8)** to the **Adaptor (#10)** by slipping a **Hose Clamp (#11)** over the **Hose (#8)** and then slide the **Hose (#8)** onto the barbed end of the **Adaptor (#10)**. Tighten with **Hose Clamp (#11)**.
4. Attach the **Adaptor (#10)** to the **Pump Base (#12)** by sliding it on (pressure fit).
5. Before snapping on the **Cover (#2)**, insert the other end of the hose through the smallest hole on the cover and secure it to the barbed end of the **Flex Hose Base (#7)** with a **Hose Clamp (#11)**.
6. Snap the entire **Cover (#2)** unit back onto the **Tank (#1)**. Set the **Filter (#6)** into the remaining hole on the **Cover (#2)**.

Warning! Position the electrical cord and plug so that it is not in contact with coolant or wet surfaces.

Operation

1. Make sure the magnetic **Flex Hose Base (#7)** is near your workpiece and the magnetic base is secure to the metal table you are working on. The tip of the **Hose (#8)** on the **Flex Hose Base (#7)** should be almost contacting the workpiece.

Operation (continued)

2. Make sure the lever on the **Flex Hose Base (#7)** is off (perpendicular to the hose). Fill the **Tank (#1)** with coolant through the **Filter (#6)**.
3. If your worktable has a groove around it to recycle the coolant, run the hose (not provided) from the table into the **Filter (#6)**.
4. Turn the lever on the **Flex Hose Base (#7)** parallel to the hose and plug in the pump to begin flow. **Caution: Recycled coolant will become very hot; contact with hot coolant could result in personal injury.**

Maintenance

Make sure the pump is not plugged in when servicing the unit.

1. When the coolant tank is empty, remove the **Pump Base (#12)** and clean off any built-up residue or debris from the bottom of the **Tank (#1)**.
2. Periodically remove the **Filter (#6)** and clean it; remove any trapped metal filings.
3. Occasionally disconnect the **Flex Hose Base (#7)** and check for built-up residue. Clean if necessary.

Parts List

Part No.	Description	Qty.
1	Tank	1
2	Cover	1
3	Pump	1
4	Pan Screw	3
5	Hex Nut	3
6	Filter	1
7	Flex Hose Base	1
8	Hose	1
9	Snap Ring	2
10	Adaptor	1
11	Hose Clamp	2
12	Pump Base	1

PLEASE READ THE FOLLOWING CAREFULLY

THE MANUFACTURER AND/OR DISTRIBUTOR HAS PROVIDED THE PARTS DIAGRAM IN THIS MANUAL AS A REFERENCE TOOL ONLY. NEITHER THE MANUFACTURER NOR DISTRIBUTOR MAKES ANY REPRESENTATION OR WARRANTY OF ANY KIND TO THE BUYER THAT HE OR SHE IS QUALIFIED TO MAKE ANY REPAIRS TO THE PRODUCT OR THAT HE OR SHE IS QUALIFIED TO REPLACE ANY PARTS OF THE PRODUCT. IN FACT, THE MANUFACTURER AND/OR DISTRIBUTOR EXPRESSLY STATES THAT ALL REPAIRS AND PARTS REPLACEMENTS SHOULD BE UNDERTAKEN BY CERTIFIED AND LICENSED TECHNICIANS AND NOT BY THE BUYER. THE BUYER ASSUMES ALL RISK AND LIABILITY ARISING OUT OF HIS OR HER REPAIRS TO THE ORIGINAL PRODUCT OR REPLACEMENT PARTS THERETO, OR ARISING OUT OF HIS OR HER INSTALLATION OF REPLACEMENT PARTS THERETO.

NOTE: Some parts are listed and shown for illustration purposes only and are not available individually as replacement parts.

Assembly Drawing

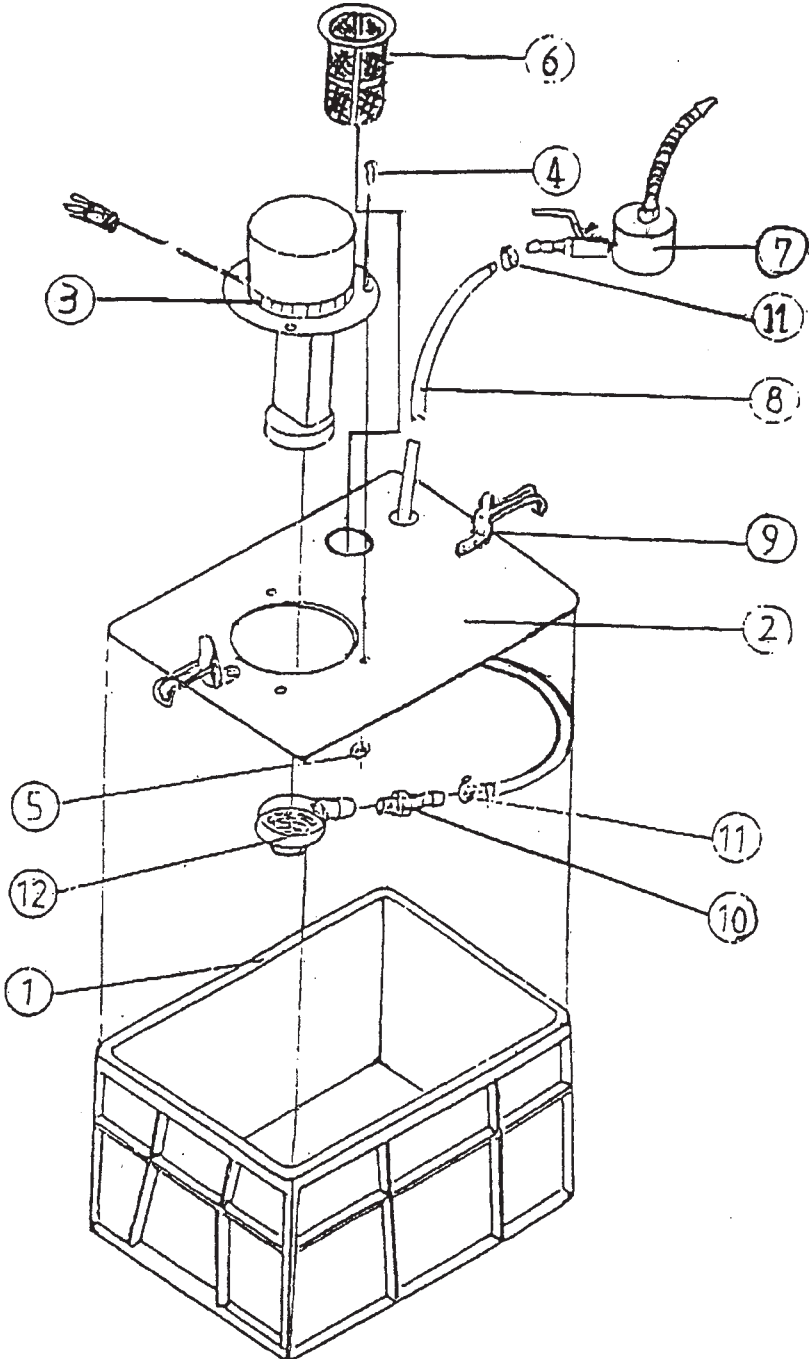

Free Manuals Download Website

<http://myh66.com>

<http://usermanuals.us>

<http://www.somanuals.com>

<http://www.4manuals.cc>

<http://www.manual-lib.com>

<http://www.404manual.com>

<http://www.luxmanual.com>

<http://aubethermostatmanual.com>

Golf course search by state

<http://golfingnear.com>

Email search by domain

<http://emailbydomain.com>

Auto manuals search

<http://auto.somanuals.com>

TV manuals search

<http://tv.somanuals.com>