

Installation & Operating Manual



Trident Boilers: SF160, SF260, SF360



We suggest that our hearth products be installed and serviced by professionals who are certified in the U.S. by the National Fireplace Institute (NFI) as NFI Specialists.



SAFETY NOTICE

PLEASE READ THIS ENTIRE MANUAL BEFORE YOU INSTALL AND/OR USE YOUR NEW BOILER. FAILURE TO FOLLOW INSTRUCTIONS MAY RESULT IN PROPERTY DAMAGE, BODILY INJURY, OR EVEN DEATH.

IF THIS HARMAN BOILER IS NOT PROPERLY INSTALLED, A HOUSE FIRE MAY RESULT. FOR YOUR SAFETY, FOLLOW INSTALLATION DIRECTIONS.

CONTACT LOCAL BUILDING OR FIRE OFFICIALS ABOUT RESTRICTIONS AND INSTALLATION INSPECTION REQUIREMENTS IN YOUR AREA.

CONTACT YOUR LOCAL AUTHORITY (SUCH AS MUNICIPAL BUILDING DEPARTMENT, FIRE DEPARTMENT, FIRE PREVENTION BUREAU, ETC.) TO DETERMINE THE NEED FOR A PERMIT.

Cette guide d'utilisation est disponible en français. Chez votre concessionnaire de Harman Stove Company.

SAVE THESE INSTRUCTIONS



Congratulations,

You have just purchased the finest wood / coal boiler available. Harman Trident boilers are constructed of high quality materials and are manufactured by a highly skilled team of assemblymen. Each boiler is inspected and pressure tested for quality assurance.

This manual is designed to provide all of the basic information needed for a safe and proper installation. However, there are many skills needed that can not be learned by reading this manual. Harman Stove Company recommends that the installation be performed by a plumbing and heating expert.

The Harman Trident Boilers are designed to operate safe, easy and automatically. You may however, need to learn a few basic skills to maintain a fire. Especially if this is your first venture into solid fuel burning. If you have any problems, re-read these instructions. If you can not resolve the issue(s), Contact your Harman Stove dealer.

TABLE OF CONTENTS

Packing List	4
Installation	5
Aquastat	6
Wiring	7
Venting	7
Plumbing	8
Operating Instructions	10
Starting a Wood Fire	10
Starting a Coal Fire	11
Loading Fuel	11
Shaking Ashes	11
Safety Tips	12
Maintenance	13
Specifications	13
Warranty	14

Packing List

The Following items are supplied with your Harman Trident Boiler:

Please notify your Harman Dealer if you are missing any items.

- Shaker Handle
- Johnson Controls Aquastat - (3) pieces; A350 Controller w/ Sensor wire
S350 Stage Module
Y350 Power Supply
- Immersion Well
- Din Rail and (2) End Clamps
- Terminal Box
- Terminal Block and (2) #8-32 nuts
- Pressure Relief Valve (30 psi.)
- Temperature / Pressure Gauge
- Automatic Draft Control Assembly
- (1 pc.) Flex Conduit w/ (2) 90° Fittings w/ nuts, and (3) Chase Nipples w/ nuts
- (2) Manual Draft Control Knob Assembly
- (3) Brass Coil Spring Handle
- Ash Pan
- Warranty Registration Form

Notice:

The Aquastat controls supplied with the Trident Boiler are designed only to maintain water temperature within the boiler. The actual heating system is controlled separately by your thermostat(s) opening zone valves or energizing circulation pump(s).

Do not attach a thermostat to the supplied controls.

Installation

Getting Started

The sheet metal sides and top are easily removed to reduce the chance of dents and/or scratches in the finish. Simply lift the top off, and that will allow the sides to be pulled away and up, for removal. To re-install, slide the channel, at the bottom of each side piece, over the lip at the bottom of the boiler, and hold downward while moving the side panel into place. Then slide the top down over the sides.

NOTE: The sheet metal top holds the sides in place, thus, no bolts or screws are needed.

CAUTION: BOILER SHOULD NOT BE INSTALLED CLOSER THAN 36 INCHES (915 MM) TO ANY COMBUSTIBLE MATERIAL

Locating Boiler

Place the boiler as close to the chimney as possible, while still maintaining the above mentioned clearances. Bolt the shaker handle on to the block on the side of the boiler, using the (2) 5/16 X 3/4 in. bolts and lock-washers.

Assembly

Install the Temperature/Pressure Gauge into the pipe stub in the center of the round plate on the front of the boiler (FIG. 1)

Install the A350 sensor wire all the way into the immersion well and screw the well into one of the top holes on the face of the boiler.

Turn the pressure relief valve into the stub on top of the boiler, next to the supply outlet fitting.

NOTE: Use teflon tape to seal the threads on all fittings. Any unused fittings must be plugged.

Bolt the two manual draft controls through the holes in the top load door. (FIG.2) The draft control knob should spin freely and open to a distance of approximately 3/8 in. from the door surface, while being able to close against the door surface.

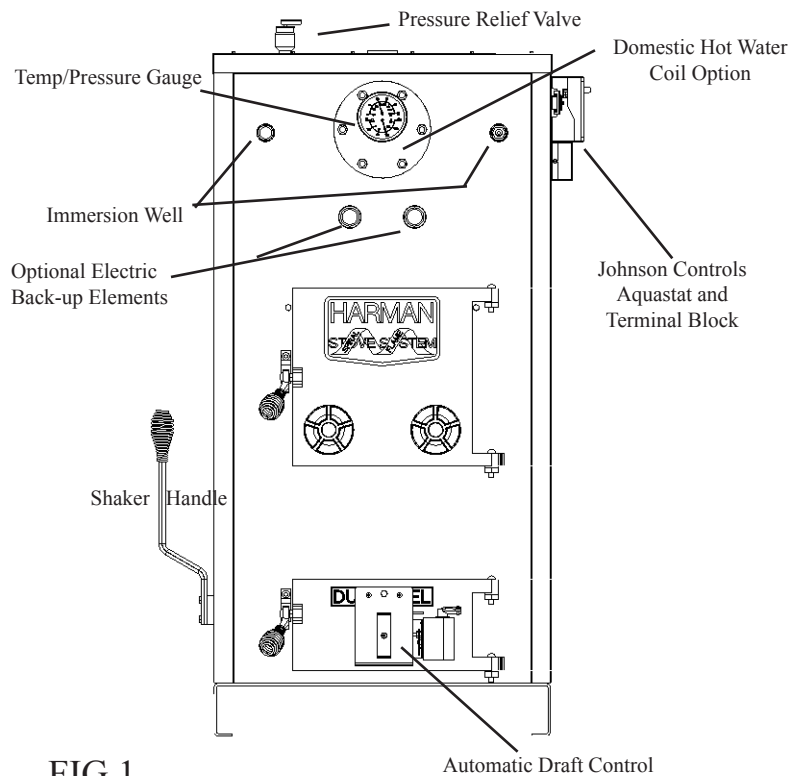

FIG.1

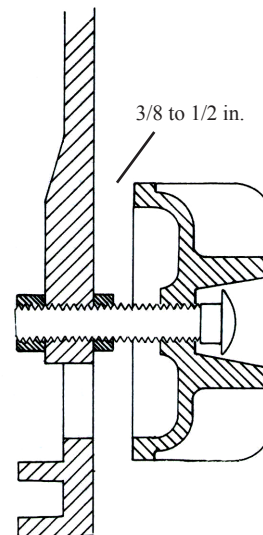

FIG.2

Installation

Bolt the Automatic Draft Control through the 1/2 in. hole in the center of the bottom door. Be sure to hold the Draft Control straight while tightening. Feed the two wires from the draft motor through the flexible conduit and a 90° fitting. Secure the fitting to the draft motor and that end of the conduit at this time. Check the flapper door on the Automatic Draft Control assuring that it moves freely.

Install the (3) brass coil spring handles onto the door latches and the shaker handle. Start the spring handle onto the shaft and twist it counter-clockwise while pushing.

Aquastat Installation

(See optional items, page 7) Lay the din rail on a flat surface, with the flat side down. Secure one end clamp, on the left side. Slide the A350 controller onto the rail from right to left until it is against the end clamp. Slide the Y350 onto the rail and guide the plug-in connector, joining it to the A350. Next, install the S350, again, guiding the plug-in connector carefully. Install the other end clamp to the right side of the din rail. Remove the covers from all three controls by loosening four screws each. Install the terminal box to the controls using (3) chase nipples and locknuts, supplied with the kit. Using the four holes in the terminal box, mount the terminal box and controls to the boiler sheet metal side as shown in Fig.1. Using (2) #8-32 nuts, install the terminal block onto the studs located inside the terminal box.

Wiring Diagram

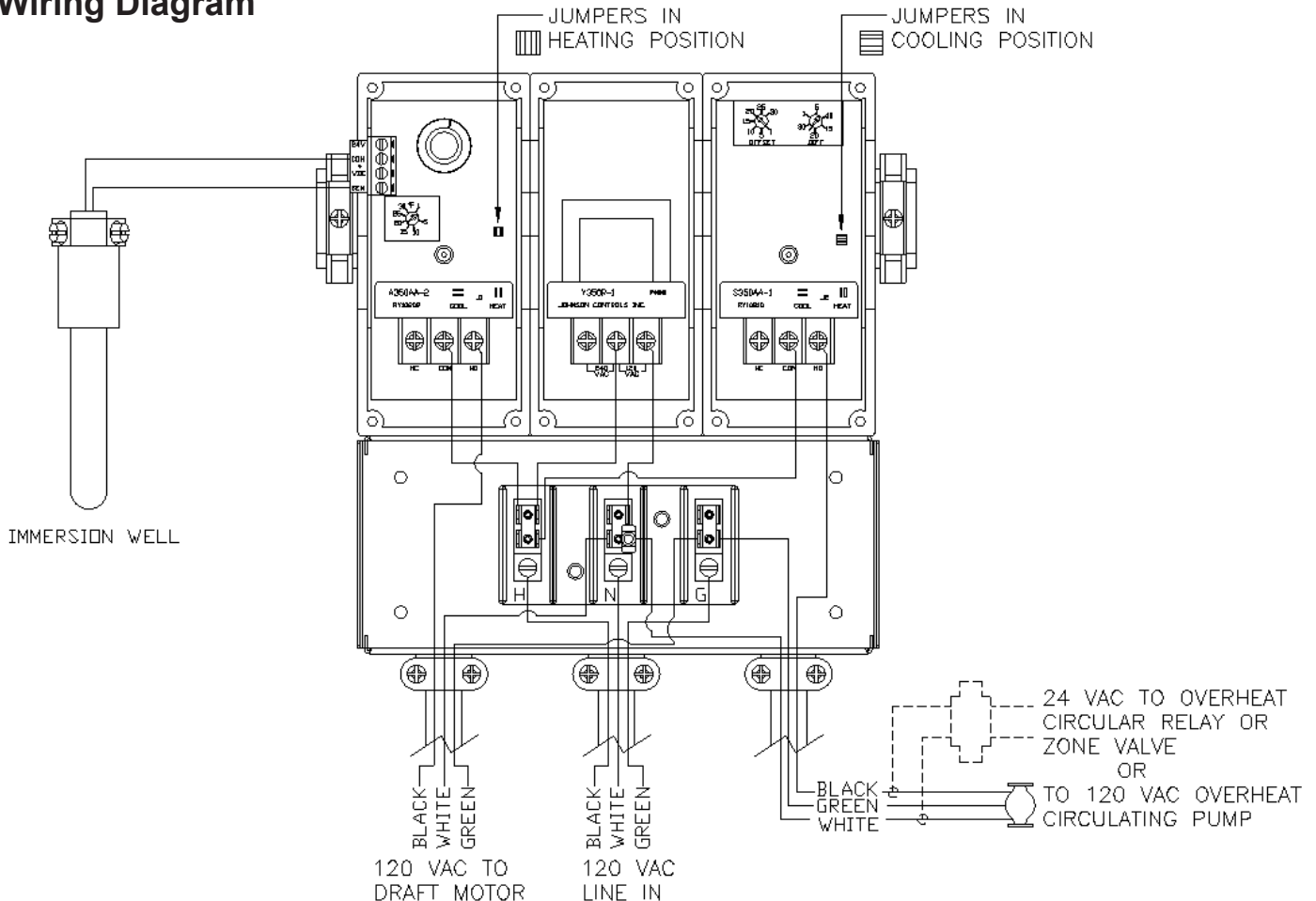

FIG.3

SF160 / 260 / 360

Installation

Wiring and Electrical

Following the wiring diagram, run all wires to their designated connections. Save the main power for the last hook-up, and leave the breaker in the off position. The sensor wires attach to the A350 Controller on the terminals marked “sen” and “com”. Make sure the sensor is submerged fully into the well and secured with the set-screws.

Setting The Aquastat

Inside the A350 control, you will see a square jumper, and a differential dial. Be sure the jumper is in the “Heating” position. The differential dial is set to determine how low, below the temperature set point, you want the water temperature to go before the Automatic Draft Control opens. A good initial setting for this dial is 5°. Be sure the 120V wires are attached to the common and the normally open terminals, and replace the cover. The external dial is set for the water temperature you wish to maintain, a good setting is 180°.

Inside the Y350 control, ensure that your wires are connected to the 120VAC terminals, and replace the cover.

Inside the S350 control, which is used as overheat protection, you'll see two dials; offset, and differential. There is also a jumper which, in this case, gets placed in the “cooling” position. The offset dial sets the number of degrees above the A350 setpoint that you want the overheat dump to activate. A good set point would be 20°. That would mean that if the water reaches 200°, using the A350 setpoint of 180°, the S350 would close it's contacts and energize the overheat dump zone. The differential dial sets the point that the overheat dump would stop. With the differential set at 15°, using the temperatures above, the circuit would re-open, stopping the overheat dump at a water temperature of 185°. The 120V wiring is attached on the normally open and the common position. The normally closed position is not used.

Re-install the covers onto the three Controls.

Optional Items

There is a domestic hot water coil available for your Trident Boiler. The coil installs in the front of the boiler, and allows your domestic water to be heated by the heating system water. Install the coil now, by removing the round plate and replacing it with the coil and it's round plate. Be sure to tighten the bolts evenly, to ensure a good seal.

If electric back-up is desired, install now. There will be two additional control boxes to add to your aquastat, which will require the use of a longer din rail. The two heating elements will install into the front of the boiler as shown in Fig. 1



FIG.4

Venting

The Harman Trident Boiler must be installed into a chimney approved for solid fuel burning appliances. In the U.S., the boiler must be connected to; (1) a prefabricated chimney complying with the requirements for Type HT chimneys in the Standard for Chimneys, Factory Built, Residential Type and Building Heating Appliances, UL 103. Or; (2) a code approved masonry chimney with a flue liner. In Canada, with prefabricated chimney systems tested and listed to the High Temperature Chimney Standard ULC S-629, or with a code approved masonry chimney. The minimum recommended height for any chimney is 16 ft. (4.8m) above the flue collar. Do not reduce flue diameter. Nominal size flue is 8 X 8 in. or equivalent, up to 8 X 12 in. Codes also require that the chimney must extend a minimum of

Installation

3 feet (0.9m) above the point at which they exit from the roof, it must also extend 2 feet (0.6m) above the highest point within a 10 ft. (3m) radius.

DO NOT CONNECT THIS UNIT TO A CHIMNEY FLUE THAT IS SERVING ANOTHER APPLIANCE.

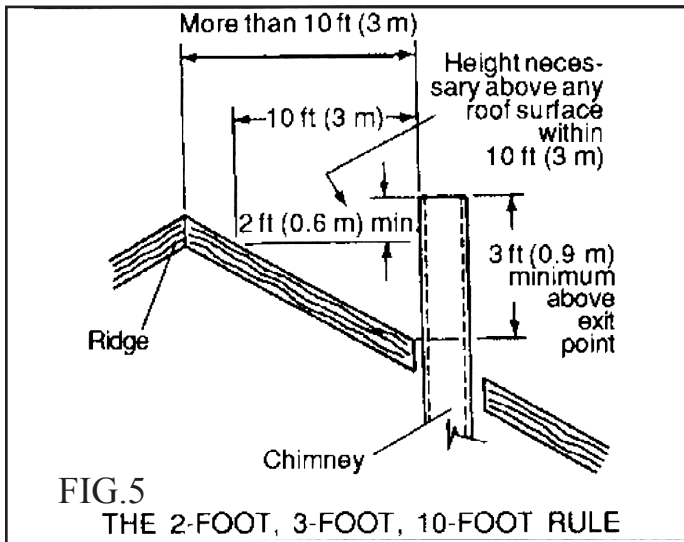

Limit connector pipe to 8 ft. or less, with no more than two elbows. All horizontal sections should have 1/4 in. rise per foot. The chimney must be capable of providing a draft reading of at least .06 in. of water column. A barometric damper can be installed to prevent excessive and erratic draft. All connector pipe should be secured with sheet metal screws at each joint.

Notice:

The Aquastat controls supplied with the Trident Boiler are designed only to maintain water temperature within the boiler. The actual heating system is controlled separately by your thermostat(s) opening zone valves or energizing circulation pump(s).

Do not attach a thermostat to the supplied controls.

Plumbing

The Harman Trident Boiler can be used as a "Stand Alone" boiler or as an add-on to an existing hot water heating system.

The diagrams in this manual are meant to show the necessary equipment and piping. Your system may look very different. However, if configured properly, the same results will be achieved.

Fig. 6 shows a typical plumbing diagram for tying into an existing system. This method provides water circulation between the two boilers with a circulating pump. In this setup, the domestic water coil in the existing boiler will be heated, making it unnecessary to install a water coil in the Trident Boiler.

Tying-in to an existing boiler must be done in the return line between the circulator and the existing boiler. Run a pipe from there to a small circulator, and then into the 1-1/4 in. fitting on the rear of the Trident Boiler. Next run a pipe from the 1-1/4 in. fitting on the top of the Trident Boiler to a Tee fitting in the supply line of the existing boiler. This Tee fitting must be installed between the existing boiler and the Flow Control Valve, as shown in Fig. 6. An air valve should be installed on this line also.

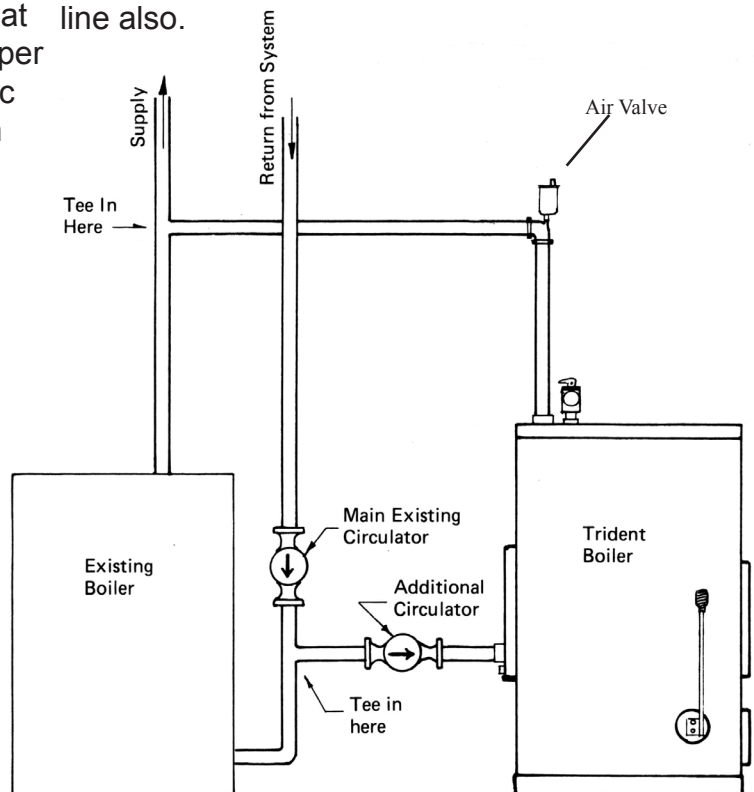

Installation

The circulator installed between the two boilers may be hooked up to run continuously during the heating season or, an additional S350 control (not supplied) could be installed to turn it on and off automatically. This control must be used as a "close on rise of temperature" (jumper in cooling position).

Harman Stove Company recommends that 1-1/4 in. pipe be used between the two boilers. Also recommended is that the first section of pipe off of the top of the Trident Boiler be threaded galvanized or threaded black-steel pipe.

The Harman Trident Boiler is supplied with a dual function aquastat. The A350 is used to control the automatic draft control whether open, to increase heat, or closed, to decrease heat. The S350 is used as overheat protection. Since a wood or coal fire is still producing heat when the draft is closed, this overheat protection is required. You could have the S350 energize a circulating pump or a zone valve separate from the heating system, or it could be hooked up so that it flows the heated water throughout the system. Either way, it must be able to flow away from the boiler.

Figure 7 shows a typical schematic of the Trident boiler as a "stand alone" system. Note; the crossover pipe (#12) is not totally necessary but is recommended to provide circulation within the boiler while the heating system is satisfied. This will ensure an even temperature within the boiler. The tempering valve shown (#10) is to prevent excessive temperature of the domestic water.

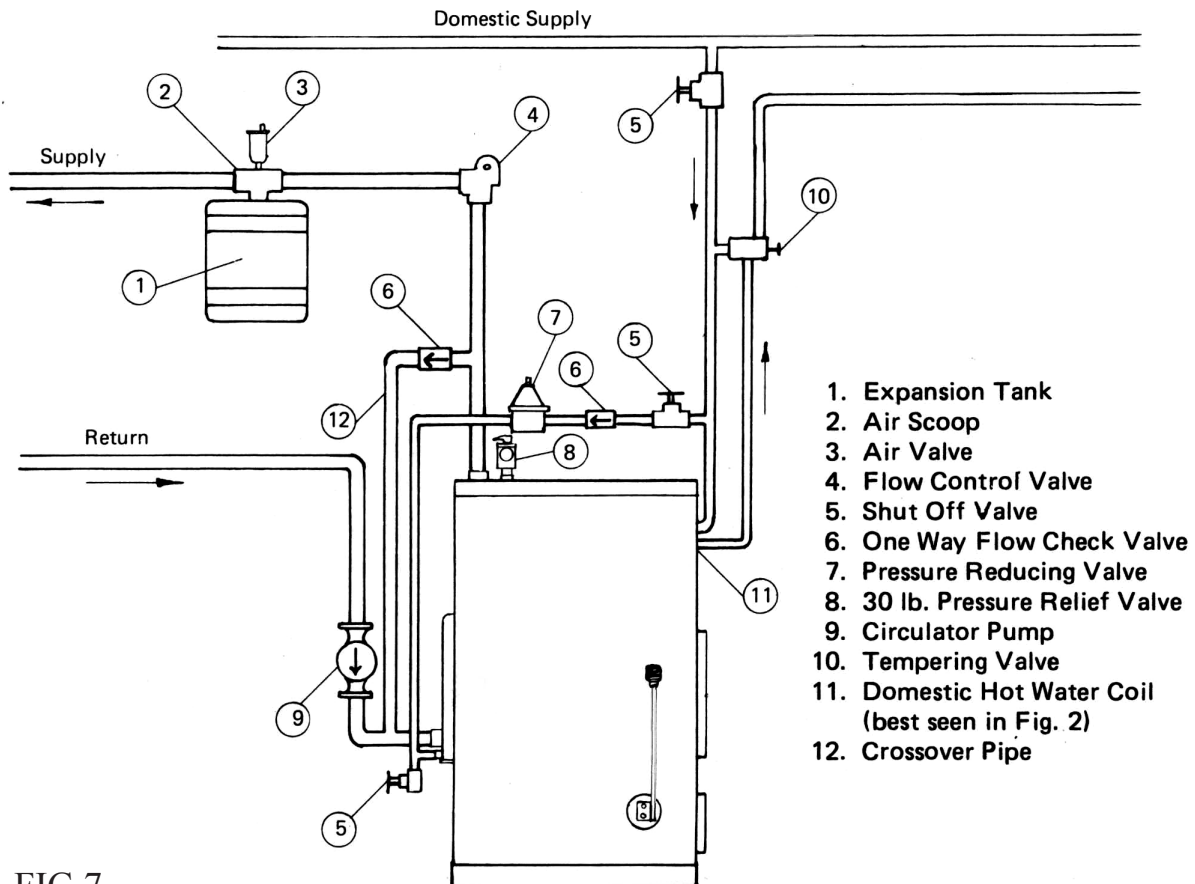

FIG.7

Operation

Automatic Draft Control

The heat output is regulated by the automatic draft control on the bottom door. The electric motor (A) opens and closes the flapper door (B). Opening and closing the flapper door regulates the air flow into the firebox.

The maximum air flow can be adjusted by turning the adjusting bolt (C). Turn counter-clockwise for more air, and clockwise for less air. Adjust this bolt only while the flapper door is in the closed position. Otherwise, motor damage could occur.

The idle air adjuster (D) controls the minimum amount of air that enters the firebox. Adjustment is made by turning the adjuster vertical for zero idle air, or horizontal for maximum idle air. It is best to start out with a medium setting as shown in Figure 9.

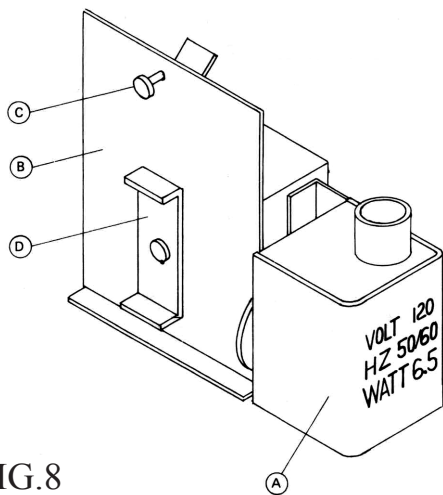

FIG.8

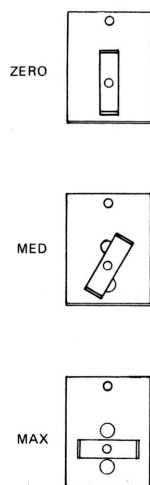

FIG.9

Starting a Wood Fire

Make sure the boiler and all piping is full of water and that all air has been purged from the system.

Never start a fire without water in the system. An explosion will occur.

Turn on electrical power to the boiler. This should cause the automatic draft control to open. Open the ash pan door to allow free air movement. With the firebox door open, crumble approximately 8 sheets of newspaper and place on the grates. Lay some small kindling on top of the newspaper. Be sure this kindling is dry and no more than 3/4 in. in diameter. Layer the kindling in a criss-cross type pattern, to allow maximum air flow. Next lay some larger pieces of wood on top of the kindling (approximately 2 in. diameter). Using a match or lighter, light the paper just inside the door. Close and latch the firebox door and allow the fire to burn a few minutes. After about five minutes, close the ash pan door and re-open the firebox door an inch or two, to allow the smoke to clear. Add 4 or 5 larger logs (about 4 in. diameter) to the well established fire and close the firebox door. Leave the ash pan door open for about five minutes only. Now open the firebox door using the same method as before, always closing the ash pan door before opening the firebox door. Now you can load the firebox to the desired level. You may load wood to the top of the firebox. Close and latch the door. The ash pan door may again be opened to speed the ignition process.

Do not leave the boiler unattended with any door open.

After the wood is burning well, close the ash pan door. The automatic draft control will now regulate the fire, based on temperature demand.

The idle air adjuster must be tuned to where the fire doesn't go out during long periods with no demand. Experience will dictate the best setting for your installation. Normally, the two manual draft controls on the firebox door are kept closed while burning wood.

Operation

Starting a Coal Fire

Make sure the boiler and all piping is full of water and that all air has been purged from the system.

Never start a fire without water in the system. An explosion will occur.

Turn on electrical power to the boiler. This should cause the automatic draft control to open. Open the ash pan door to allow free air movement. Use the same procedure as starting a wood fire except, do not load the larger diameter wood. Use wood about 2 in. diameter maximum. This size will form a very hot charcoal bed in less time. Again, the ash pan door may be opened periodically to speed the ignition process.

DO NOT LEAVE THE BOILER UNATTENDED WITH ANY DOOR OPEN.

When you have accumulated a substantial charcoal bed, start adding a thin layer of coal. Pea or Nut sized coal is better for starting than Stove coal.

When the first layer is burning with some blue flame, continue to add thin layers of coal until there is a solid bed of burning coal. Let each layer burn a blue flame before adding another layer. Additional coal can be layered in until the bed is approximately 10 inches deep. By now, you should have the ash pan door closed, and the automatic draft control will continue to regulate the fire.

The idle air adjuster may need to be set for slightly less air for coal than wood. Here again, experience will dictate the best setting. The maximum air bolt can be turned all the way "counter-clockwise" to allow for a quicker recovery. Never adjust this bolt with the flapper open.

The two manual draft controls, on the firebox door, are used to allow secondary air to pass over the fire when burning coal. This helps to burn the gasses that are emitted from the coal as it is heated. Your setting for these draft controls should be between 1/2 and 1 complete turn from closed. Adjust both controls equally.

Loading

Coal should never be added unless there is a reasonably hot fire. The coal bed should be bright and vigorous. If you have an active coal bed, full loads can be added at any time. If not, add new coal in layers, as described in starting a coal fire.

Shaking the Grates

Shaking should be done only when there is a well-established fire. The frequency of shaking will depend on the degree of burning. Twice a day shaking is recommended. The best results are achieved with short, choppy strokes as opposed to long, even strokes. Full rocking of the grates may allow burning coal to fall into the ash pan. The amount of shaking is critical, too much can disrupt the fire bed, and too little will restrict air-flow. The proper amount of shaking is normally achieved when hot red coals first start to drop through the grates into the ash pan.

Every effort should be made to not let a coal fire burn down too low. This will cause the reloading process to be much longer, with a real good chance of losing the fire altogether.

Do not shake or stir with a low fire. Open the ash pan door to get maximum air flowing into the firebox. Once burning is restored, close the ash pan door and add a layer of coal to the fire bed. Follow the instructions under Starting a Coal Fire. When the new coal is thoroughly ignited, and there is a substantial bed of hot coals, the grates may then be shaken.

Ashes and Ash Removal

Ashes should never be allowed to accumulate above the top of the ash pan. Ashes in contact with the bottom of the grates act as insulation, which intensifies the heat on the grates and causes them to sag or warp. Also, too much ash accumulation will restrict air-flow which will make fire maintenance more difficult. Place ashes in a sealed metal container, outside, until they are cooled enough for final disposal. Coal produces considerably more ash than wood, so the intervals between emptying are much shorter.

Operation

Safety Tips

When opening the firebox door, it should be cracked, slightly open, for a few seconds to allow air in to burn any gases which may be present. This will also allow smoke to be drawn away from the door. Whenever the ash pan door is open, it should be closed before opening the firebox door.

The firebox should never be filled with excessive coal to where the flue exit is blocked or impeded in any way.

Burning coal produces Carbon Monoxide. If the flue exit is blocked, the Carbon Monoxide can be forced out of the boiler, into the room, with possible FATAL consequences.

With the exception of start-up or freshening of the fire, or performing ash removal, the ash pan door should be kept closed.

Never install a Harman Trident Boiler into a chimney with a history of down-drafts.

Keep Children Away-- May Cause Serious Burns.

CAUTION: All surfaces of the boiler are hot. Do not touch. Keep children away. Serious burns will result if touched. This is a heat producing appliance.

DANGER: Fire Hazard, Do not use chemicals or flammable liquids to start or "freshen-up" a fire. Severe burns or a house fire may result. Do not burn Garbage, Gasoline, Thinners, Oil, Kerosene Etc. An explosion, a house fire or serious personal injury could result. Keep all such liquids well away from this boiler.

During the first few hours of burning, a blue smoke may be observed rising from the boiler. This is the paint going through the curing process. It is advisable to increase the amount of fresh air in the room during this break in period. This can be achieved by opening doors and windows. Don't be alarmed, this is normal and will only last a short while.

Chimney Problems

Not Enough Draft- Chimney is too low. The general rule for chimneys is 16 feet tall, and two feet higher than anything ten feet around it.

Air may be leaking in around a loose fitting clean-out door.

Too many elbows in connector pipe, or seams and joints of connector pipe are not secured properly.

Improperly sized chimney or stovepipe.

Chimney may be blocked with creosote or bird nests or similar obstructions.

Cracked or defective chimney flue or liner.

Down Drafts- Trees or other topographical barriers may impede on chimney performance causing air currents to be pushed downward into the flue. This can also be caused by neighboring buildings or other chimneys.

Creosote and condensation- If creosote or condensation runs out of the chimney or stove pipe, check the following; Chimney cap or liner may be defective, Boiler may be positioned too far away from the chimney which would not allow the chimney to warm, Wood being burned may be green or wet, Boiler may be over-sized for the residence causing it to be burned on low too often.

Excessive Draft- This can be controlled with a barometric damper in the stove pipe.

Maintenance

Maintenance

The spiral chamber is basically self-cleaning. However, if there is a draft problem and you have been burning wood for a long time with little demand, the spiral chamber will need to be cleaned. To clean the spiral chamber, remove the stovepipe and scrape any creosote or debris from the top and front of the chamber. The rear of the chamber should not have much accumulation. If it does, clean it out.

NOTE: 1/4" to 1/2" of creosote in the spiral chamber is normal.

The pipes inside the firebox will accumulate creosote if the demand for heat is too low, when burning wood. 1/8" to 1/4" of creosote is normal on the pipes and firebox walls. If more creosote has accumulated, it should be scraped off of these surfaces.

NOTE: Creosote in the firebox can be burned off by burning coal for a few days.

The fire bricks may become cracked during the course of normal operation. A cracked brick that is still in place, is still doing its job, and need not be replaced immediately. If a brick is broken, and has fallen out of place, it should be replaced before any further burning occurs. The firebricks used in the Trident Boiler are available for replacement from your Harman dealer.

Gaskets on the doors are there to regulate air to the firebox. If a gasket is failing, you'll notice difficulty in controlling the fire. Inspect the gaskets regularly, and replace with Harman supplied material only.

Specifications	SF-160	SF-260	SF-360
Heating Capacity (Square Feet)	2200 Max.	3200 Max.	4500 Max.
Approximate BTU per hour (wood or coal)	90,000	130,000	180,000
AMP Rating	40	40	40
Water Capacity (US Gallon)	25	32	42
Weight	640 Lbs	780 Lbs	925 Lbs
Hydro-Pressure Tested	Yes	Yes	Yes
Firebox Dimensions (inches)	16W x 22L x 19H	18W x 26L x 20H	18W x 30L x 25H
Recommended Log Length (inches)	19	23	27
Door Opening Size (inches)	11 x 13	13 x 13	13 x 13
Overall Dimensions (inches)	23W x 23.5L x 45H	26W x 27.5L x 45.5H	26W x 31.5L x 51.5H
Flue Size (diameter)	6 inch	7 inch	7 inch
Flue Height (top of flue)	37.5 inches	38.75 inches	44 inches
Number Of Grates (10 Lbs. Each)	4	5	6
Type Of Fuel	Coal / Wood	Coal / Wood	Coal / Wood
Water Inlet and Outlet Size	1.25 NPT	1.25 NPT	1.25 NPT
Automatic Draft Control	Yes	Yes	Yes
Aquastat	Yes	Yes	Yes
Temperature / Pressure Gauge	Yes	Yes	Yes
ASME Pressure Relief Valve	Yes	Yes	Yes
Ash Pan With Handle	Yes	Yes	Yes
Domestic Hot Water Coil (optional)	4 GPM	4 GPM	4 GPM
Approximate BTU per hour (electric option)	30,000	30,000	30,000
Kilowatt Rating (electric option)	9	9	9

Warranty



1 Year Limited Warranty (commercial) 5 Year Limited Warranty (residential)

Warranty is not transferable. Harman Stove Company warrants its products to be free from defects in material and workmanship, in normal use and service, for five (5) years from the date of purchase.

If defective in material or workmanship, and if removed by the owner within 60 months of the date of installation, Harman Stove Company will, at its option, repair or replace the product as described below.

The warranty above constitutes the entire warranty with respect to Harman Stove Company product. HARMAN STOVE COMPANY MAKES NO OTHER WARRANTY, EXPRESSED OR IMPLIED, INCLUDING ANY WARRANTY OF MERCHANTABILITY, OR WARRANTY OF FITNESS FOR A PARTICULAR PURPOSE. No employee, agent, dealer, or other person is authorized to give any warranty on behalf of Harman Stove Company. This warranty does not apply if the product has been altered in any way after leaving the factory. Harman Stove Company assumes no liability for "resultant damages of any kind" arising from the use of its products. In addition, the manufacturer shall be held free and harmless from liability for damage to property related to the operation, proper or improper, of the product. THERE ARE NO OTHER WARRANTIES WHICH EXTEND BEYOND THE DESCRIPTION ON THE FACE HEREOF.

THESE WARRANTIES APPLY only if the device is installed and operated as recommended in the manual.

THESE WARRANTIES WILL NOT APPLY if damage is caused by abuse, accident, improper installation, negligence, or use beyond the rated capacity.

LABOR RESPONSIBILITY- In furnishing replacement parts, Harman Stove Company assumes no responsibility for labor expenses for service, removal, or re-installation.

MAKING A CLAIM- Any claim under this warranty shall be made to the dealer from whom this appliance was purchased. Then, contact is made with the manufacturer, giving the model, serial number, date of purchase, dealer's name and address, plus a simple explanation of the nature of the defect.

SHIPPING COSTS- The transportation charges are as follows:

- (1) Customer Pre-pays freight to Harman Stove Company
- (2) Harman Stove Company Pre-pays charges for the repaired or replacement unit.

NOTE: Prior approval, by phone or in writing, shall be made before shipping the appliance to manufacturer.

THIS WARRANTY IS LIMITED TO DEFECTIVE PARTS-REPAIR AND/OR REPLACEMENT AT HARMAN OPTION AND EXCLUDES ANY INCIDENTAL AND CONSEQUENTIAL DAMAGES CONNECTED THEREWITH.

WARRANTY EXCLUSIONS: (1) Labor (2) Firebricks (3) Door Packing (4) Paint (5) Acts of God
PLEASE READ THE LITERATURE BY THE MANUFACTURER FOR THE VARIOUS ACCESSORY DEVICES. THESE DEVICES ARE "WARRANTED BY THE MANUFACTURER" NOT BY HARMAN STOVE COMPANY. FURTHERMORE, THESE ACCESSORY DEVICES MUST BE INSTALLED AND USED ACCORDING TO THE RECOMMENDATIONS OF THE MANUFACTURER.

Some states do not allow the exclusion or limitation of incidental or consequential damages, so the above limitation or exclusion may not apply in your state.

This warranty gives you specific legal rights. You may also have other rights, which vary from state to state, which may be enforceable in a court of law.

REMEDIES - The remedies set forth herein are exclusive, and the liability of seller with respect to any contract of sale or things done in connection therewith, whether in contract, in tort, under any warranty, or otherwise, shall not, except as herein expressly provided, exceed the price of the equipment or part of which such liability is based.

CLARIFY- The above represents the complete warranty given in connection with boilers manufactured by Harman Stove Company. No other commitments, verbal or otherwise, shall apply, except by a written addendum to this warranty.

Free Manuals Download Website

<http://myh66.com>

<http://usermanuals.us>

<http://www.somanuals.com>

<http://www.4manuals.cc>

<http://www.manual-lib.com>

<http://www.404manual.com>

<http://www.luxmanual.com>

<http://aubethermostatmanual.com>

Golf course search by state

<http://golfingnear.com>

Email search by domain

<http://emailbydomain.com>

Auto manuals search

<http://auto.somanuals.com>

TV manuals search

<http://tv.somanuals.com>