

HOW TO PLAY

Counting with Chuck My Talkin' Truck combines the fun action of playing interactively with your truck with the friendly world of Tonka to encourage learning. With numbers and special sound effects, the learning fun goes on for hours.



When Counting with Chuck My Talkin' Truck is in the closed position, your child can press the button on Chuck's door to hear Chuck and some great sound effects as they play!

Push the button on the top of Chuck's hat to open him up and you open up a whole new world of learning for your child!

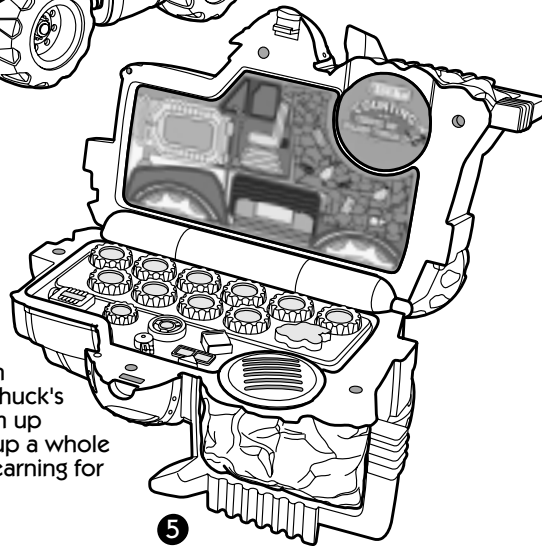

5

MESSAGE TO PARENTS

Thank you for bringing home **Counting with Chuck My Talkin' Truck**. This is a wonderful educational product for your child. It's exciting to learn with Tonka!

Chuck will help your child to learn about numbers and counting, while they play with their truck! These are fundamental skills combined to form the building blocks for future development.

Please read the instructions carefully and learn about the many different features of this exciting toy. This will allow you to easily explain them to your child in a way that is easy for them to understand.

Please note: **Chuck My Talkin' Truck** will not understand a button push if it is made while the unit is talking. Please be sure not to answer any questions while the unit is talking or making a sound or it may not understand your response.

1. Once you have opened up the toy, press the ON button. You will hear a friendly greeting.

2. Choose the mode/way you wish to play: TEACH or QUIZ.

TEACH MODE: This mode identifies the button pressed. **Chuck My Talkin' Truck** will prompt the child to push a button. Each time a button is pressed, the unit will either identify the button, or you will hear the sound effect associated with the button if it was a **SHAPE** button.

QUIZ MODE: This mode asks many different types of questions to test your child's comprehension. Some questions will ask your child to find a specific number, what might come before or after a certain number, or to press a button to hear Chuck count to that number.

TURNING THE UNIT OFF

This unit features an automatic shut-off feature to help prolong battery life. After a brief period of inactivity, the unit will prompt your child for a response. If the child doesn't respond by pressing a button, the unit will continue prompting the child for a response for 60 seconds. After that time, the unit will automatically turn itself off. Pressing the ON button will then restart the toy.

NOTE: Your child needs to wait until Chuck has stopped talking before pressing a number or shape button. If you press a button while he is still talking, the unit will not register that the button was pressed.

6

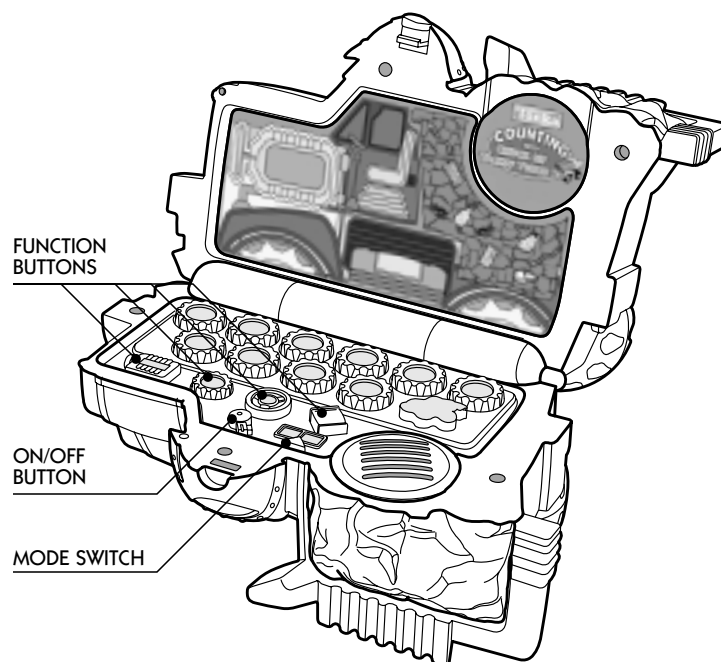

- ON/OFF BUTTON** - Press this button to turn the unit ON and OFF.
- MODE SWITCH** - Slide this switch to select between two different modes of learning: TEACH and QUIZ.
- FUNCTION BUTTONS** - Use the NUMBER buttons (1-10) to answer questions in all learning modes.
- SOUND EFFECT BUTTONS:** CHUCK THE TRUCK, ENGINE, TIRE, STEERING WHEEL, and GAS.

1

2

90- DAY LIMITED WARRANTY

Tiger Electronics, Ltd. (Tiger) warrants to the original consumer purchaser of this product that the product will be free from defects in materials or workmanship for 90 days from the date of original purchase. This warranty does not cover damages resulting from accident, negligence, improper service or use or other causes not arising out of defects in materials or workmanship.

During this 90-day warranty period, the product will either be repaired or replaced (at Tiger's option) without charge to the purchaser, when returned with proof of the date of purchase to either the dealer or to Tiger.

Products returned to Tiger without proof of the date of purchase or after the 90-day warranty period has expired, but prior to one year from the original date of purchase, will be repaired or replaced (at Tiger's option) for a service fee of U.S. \$13.00. Payments must be by check or money order payable to Tiger Electronics, Ltd.

The foregoing states the purchaser's sole and exclusive remedy for any breach of warranty with respect to the product.

All products returned must be shipped prepaid and insured for loss or damage to:

Tiger Electronics, Ltd. Repair Dept.
980 Woodlands Parkway
Vernon Hills, Illinois 60061, U.S.A.

The product should be carefully packed in the original box or other packing materials sufficient to avoid damage during shipment. Include a complete written description of the defect, a check if product is beyond the 90-day warranty period, and your printed name, address and telephone number.

THIS WARRANTY IS IN LIEU OF ALL OTHER WARRANTIES AND NO OTHER REPRESENTATIONS OR CLAIMS OF ANY NATURE SHALL BE BINDING ON OR OBLIGATE TIGER IN ANY WAY. ANY IMPLIED WARRANTIES APPLICABLE TO THIS PRODUCT, INCLUDING WARRANTIES OF MERCHANTABILITY AND FITNESS FOR A PARTICULAR PURPOSE, ARE LIMITED TO THE NINETY (90) DAY PERIOD DESCRIBED ABOVE. IN NO EVENT WILL TIGER BE LIABLE FOR ANY SPECIAL, INCIDENTAL, OR CONSEQUENTIAL DAMAGES RESULTING FROM POSSESSION, USE, OR MALFUNCTION OF THIS TIGER PRODUCT.

Some states do not allow limitations as to how long an implied warranty lasts and/or exclusions of limitations of incidental or consequential damages, so the above limitations and/or exclusions of liability may not apply to you. This warranty gives you specific rights, and you may also have other rights which vary from state to state.

For more information about Tiger Electronics, our products and special promotions, please visit our web site at: www.tiger toys.com



©, TM, & © 2000 Tiger Electronics, Ltd.
All Rights Reserved.
980 Woodlands Parkway
Vernon Hills, Illinois 60061, U.S.A.
www.tiger toys.com



©, TM & © 2000 HASBRO, INC.
Pawtucket, RI 02862
All Rights Reserved.

PRINTED IN CHINA 200100970IWT-01

INSERTING THE BATTERIES

Important Note: Battery installation should be done by an adult.

- Counting with Chuck My Talkin' Truck** requires 3 x 1.5V "AA" or "LR6" batteries.
- The battery compartment is located on the back of the unit.
- Open the battery compartment door on the individual units by sliding it back with your thumb (ILLUSTRATION 1).

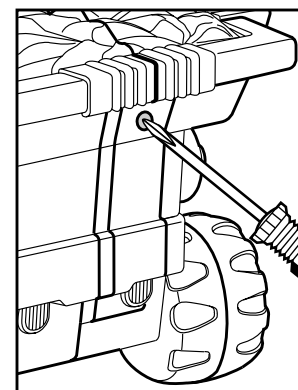

ILLUSTRATION 1

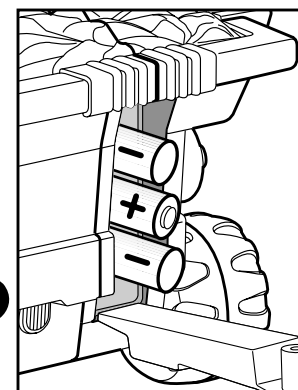

ILLUSTRATION 2

- Remove discharged batteries if necessary and insert new batteries according to the diagram provided in the battery compartment (ILLUSTRATION 2).
- Close the battery compartment door.

Note: These instructions are also stamped onto the back of the product for future reference.



3

Item No. 59233

TIGER
ELECTRONICS, LTD.
Ages 2 & Up

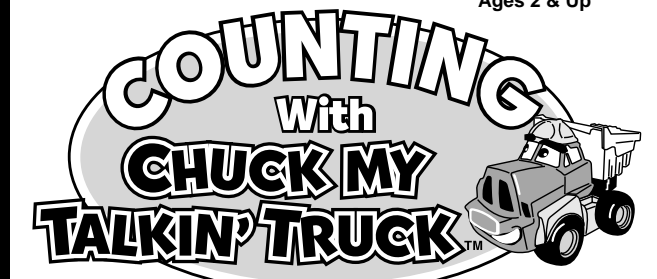

INSTRUCTION MANUAL



WHEN TO REPLACE BATTERIES

Change the batteries when the voices and sounds are garbled or seem to be slowing down during play, or when pressing a button does not trigger a response from the unit.

To ensure proper function:

- Do not mix old and new batteries.
- Do not mix alkaline, standard or rechargeable batteries.
- Battery installation should be done by an adult.
- Non-rechargeable batteries are not to be recharged.
- Rechargeable batteries are to be removed from the toy before being charged (if removable).
- Rechargeable batteries are only to be charged under adult supervision (if removable).
- Only batteries of the same or equivalent type as recommended are to be used.
- Batteries are to be inserted with the correct polarity.
- Exhausted batteries are to be removed from the toy.
- The supply terminals are not to be short-circuited.

WARNING: DO NOT DISPOSE OF BATTERIES IN FIRE, BATTERIES MAY EXPLODE OR LEAK."

TAKING CARE OF COUNTING WITH CHUCK MY TALKIN' TRUCK

To protect your **Counting with Chuck My Talkin' Truck**, follow these instructions:

Prevent spills of food and beverage on the unit.

Do not submerge the product in water. If the product needs to be cleaned, wipe gently with a barely damp, soft cloth.

Do not throw or kick the product, and do not push sharp objects through the speaker openings.

4

Free Manuals Download Website

<http://myh66.com>

<http://usermanuals.us>

<http://www.somanuals.com>

<http://www.4manuals.cc>

<http://www.manual-lib.com>

<http://www.404manual.com>

<http://www.luxmanual.com>

<http://aubethermostatmanual.com>

Golf course search by state

<http://golfingnear.com>

Email search by domain

<http://emailbydomain.com>

Auto manuals search

<http://auto.somanuals.com>

TV manuals search

<http://tv.somanuals.com>