



PRO³ Top Mount Refrigeration System Installation

H-IM-82B

July 2008

Part No. 25001901

Replaces H-IM-82A (6/06)



Refrigeration System For Outdoor Applications

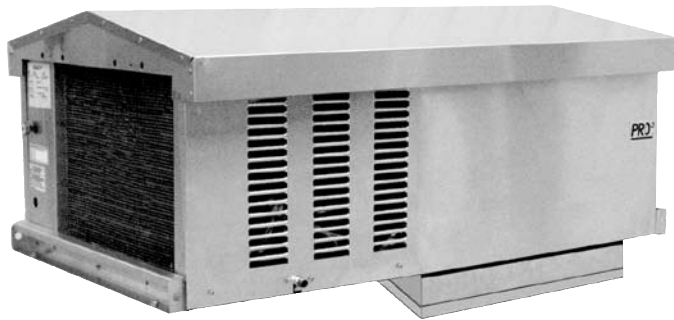

Installation and Operation Guide

Table of Contents

1. Owner's Installation Instructions

Performance/Electrical Data Specifications.....	2
Dimensional Diagrams	3
Space and Location Requirements Recommended Unit Placement.....	4
Rigging Mounting Inspection General Safety Information.....	5
Standard Installation Procedure	6
Outdoor Unit Installation Instructions.....	7

2. Freezers

Service Information Maintenance Sequence of Operation Freezer System Pre-Setpoints Electric Defrost Sequence of Operation Programming Electric Defrost Controls	8-10
--	------

3. Coolers

Defrost Controls Sequence of Operation Maintenance	11
--	----

4. Service Information

System Troubleshooting Chart.....	12
Replacement Parts	13

5. Wiring Information

Electrical Wiring Diagrams	14-19
----------------------------------	-------

6. Warranty Information

.....	20
-------	----

Performance / Electrical Data

Table 1. COOLERS – Air Defrost Systems

Model	BTUH @ 95°F		Voltage	MCA	MOPD	Unit Amps	Evap CFM	Plug Supplied	Matching NEMA Receptacle	Fig.
	35°F Box Temp	38°F Box Temp								
PTT047H2B	4,980	5,300	208-230/1/60	8.6	15	7.3	350	No	—	B
PTT063H2B	6,680	7,100	208-230/1/60	9.8	15	9.9	550	No	—	B
PTT072H2B	7,630	8,060	208-230/1/60	10.9	15	9.3	500	No	—	B
PTT099H2B	10,490	11,340	208-230/1/60	17.1	20	14.7	875	No	—	C
PTT099H2C	10,490	11,340	208-230/3/60	14.7	20	13.3	875	No	—	C
PTT128H2B	13,570	14,520	208-230/1/60	20.1	30	17.2	825	No	—	C
PTT128H2C	13,570	14,520	208-230/3/60	14.1	20	12.8	825	No	—	C

Table 2. FREEZERS – Electric Defrost Systems

Model	BTUH @ 95°F			Voltage	MCA	MOPD	Unit Amps	Evap CFM	Plug Supplied	Matching NEMA Receptacle	Fig.
	0°F Box Temp	-10°F Box Temp	-20°F Box Temp								
PTT021L6B	2,680	2,160	1,340	208-230/1/60	7.6	15	6.5	350	No	—	B
PTT031L6B	4,220	3,190	2,060	208-230/1/60	13.8	15	11.6	550	No	—	B
PTT044L6B	5,870	4,530	3,400	208-230/1/60	15.9	20	13.3	520	No	—	B
PTT052L6B	7,000	5,360	3,910	208-230/1/60	18.1	20	15.5	900	No	—	C
PTT052L6C	7,000	5,360	3,910	208-230/3/60	15.0	15	11.3	900	No	—	C
PTT069L6B	9,060	7,100	5,250	208-230/1/60	23.8	30	20.0	875	No	—	C
PTT069L6C	9,060	7,100	5,250	208-230/3/60	15.9	20	14.2	875	No	—	C

Table 3. Specifications

Model	Refrigerant	Refrigerant Charge (oz.)	Total Heat of Rejection (BTUH)	Approx. Net Weight	
				lbs.	kg
COOLERS					
PTT047H2B	22	27	6,700	192	100
PTT063H2B	22	29	8,700	207	100
PTT072H2B	22	32	9,700	211	100
PTT099H2B	22	47	16,800	270	127
PTT099H2C	22	47	16,800	265	127
PTT128H2B	22	52	18,000	290	127
PTT128H2C	22	52	18,000	285	127
FREEZERS					
PTT021L6B	404A	26	4,300	213	100
PTT031L6B	404A	28	6,300	221	100
PTT044L6B	404A	29	9,900	225	100
PTT052L6B	404A	45	10,900	275	127
PTT052L6C	404A	45	10,900	270	127
PTT069L6B	404A	47	15,300	280	127
PTT069L6C	404A	47	15,300	275	127

Dimensional Diagrams

Figure A. Medium Cabinet Dimensions without weather hood
Models PTT 021, 031, 044, 047, 063, 072

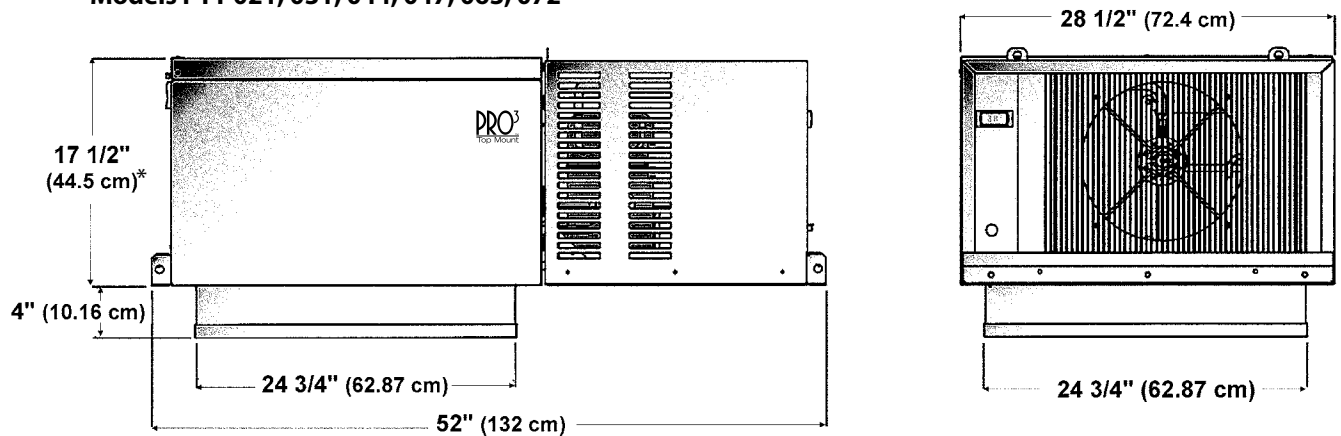

25" x 25" panel opening required for evaporator section of medium cabinet sizes.

* 21.5" with weather hood.

Figure B. Large Cabinet without weather hood
Models PTT 052, 069, 099, 128

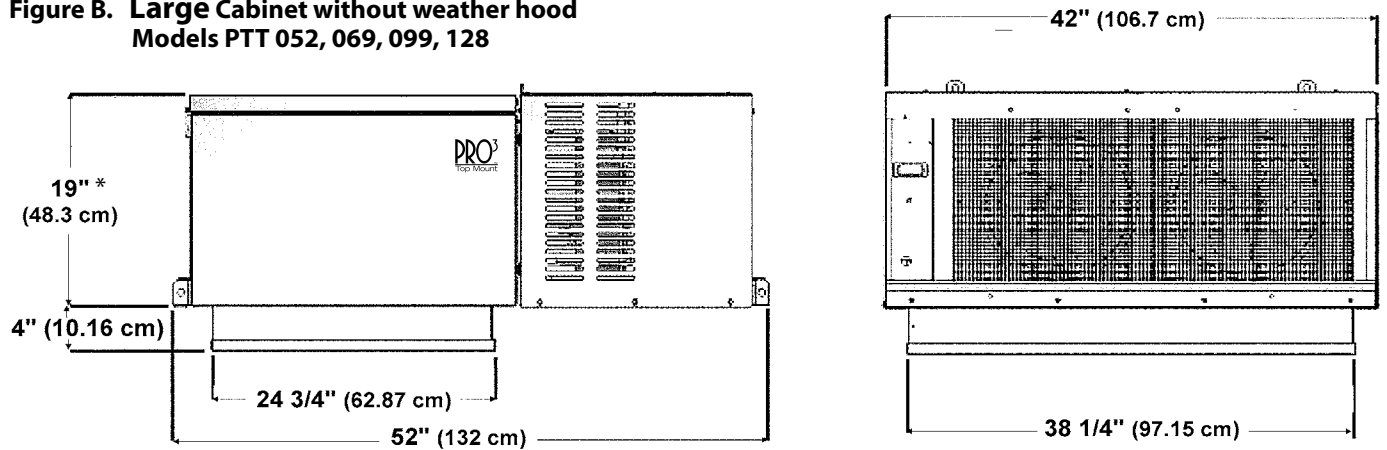

25" x 38 1/2" panel opening required for evaporator section of large cabinet sizes.

* 23.5" with weather hood.

Figure C. Medium Cabinet with weather hood
Models PTT 021, 031, 044, 047, 063 and 072

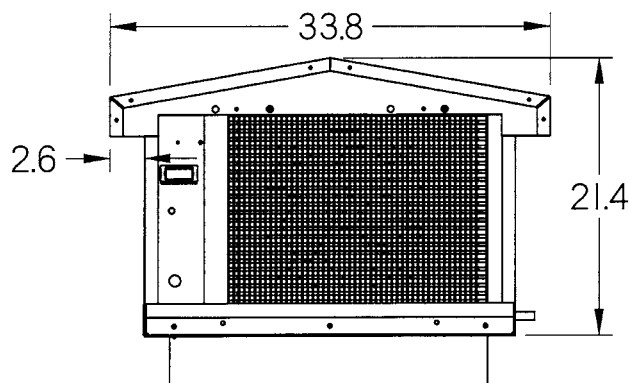
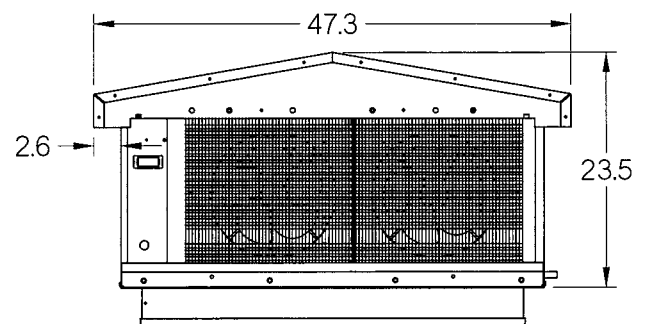

Figure D. Large Cabinet with weather hood
Models PTT 052, 069, 099 and 128



Recommended Unit Placement For PTT Models

Some general rules for the evaporator section placement which must be followed are:

1. Ensure that the structural integrity of the box can withstand the weight of the top mounted equipment.
2. The air pattern must cover the entire room.
3. **NEVER** locate the evaporator section over doors.
4. Location of aisles, racks, etc. must be known.
5. Never remove or unlock any panel cam-locks to install top mounted equipment.

NOTE: Always avoid placement of units directly above doors and door openings.

The size and shape of the storage will generally determine the type and number of units to be used and their location.

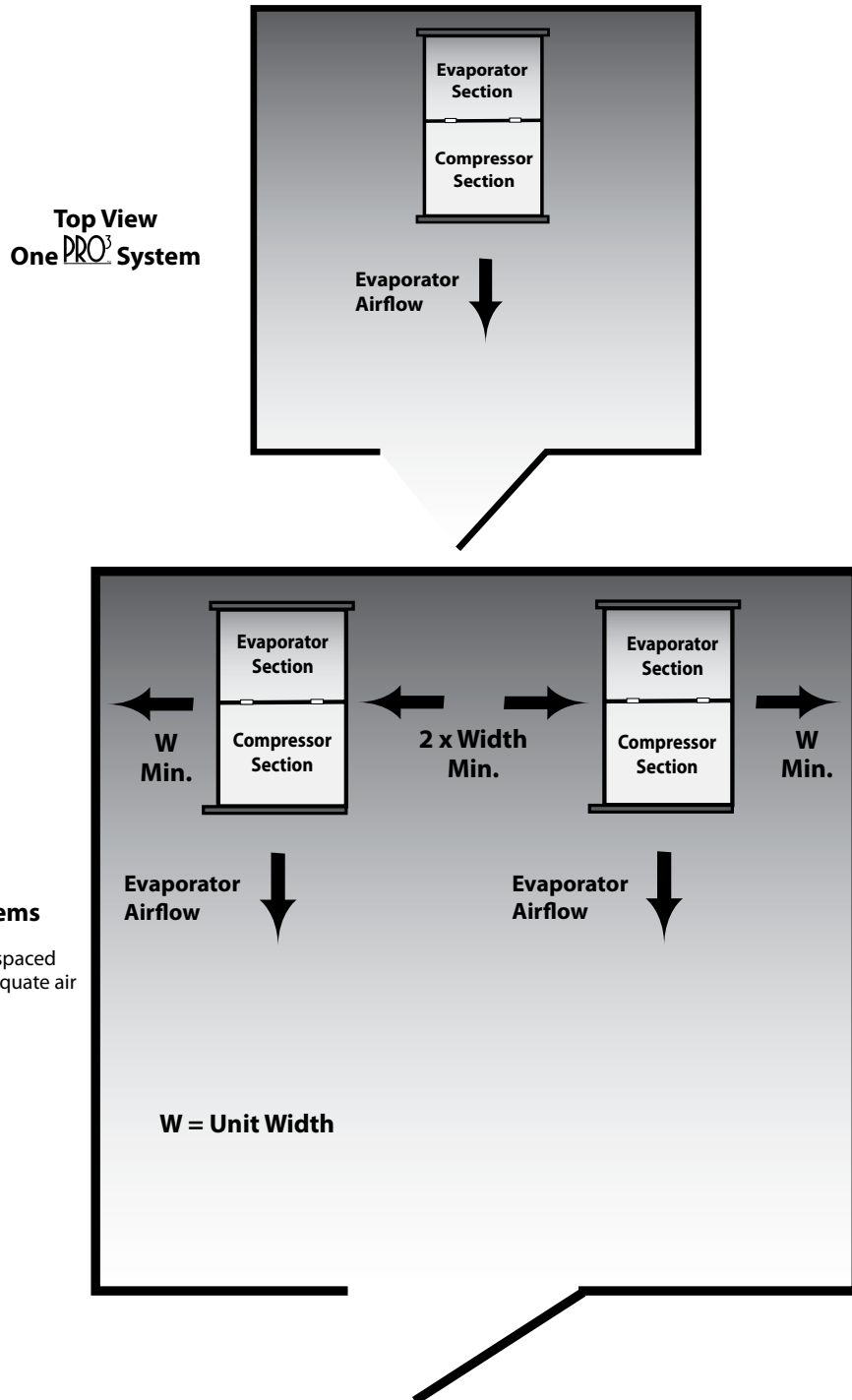

Multiple units must be spaced properly to provide adequate air circulation.

Rigging

Rigging holes are provided on all models. Caution should be exercised when moving these units. To prevent damage to the unit housing during rigging, cables or chains used must be held apart by spacer bars. The mounting platform or base should be level and located so as to permit free access of supply air. The unit weather hood may be removed for the rigging process. The condensing unit cover (wrapper) should be left in place.

Access Requirements

Provide adequate space at the compressor end of the unit for servicing. Provide two (2) feet of space above unit for service.

Mounting

The system requires an opening in the ceiling to the dimensions stated on page 3. Mounting rails are located at both ends of the chassis. Mounting rails may be used to attach unit to ceiling. Through-bolts should be insulated or non-conductive to prevent sweating. The chassis is weather stripped around the air grille and will seal to the box roof. The trim ring (shipped loose), when provided, should be installed around the air diffuser when secured with the hardware provided. Be sure to adhere to your local standard construction codes.

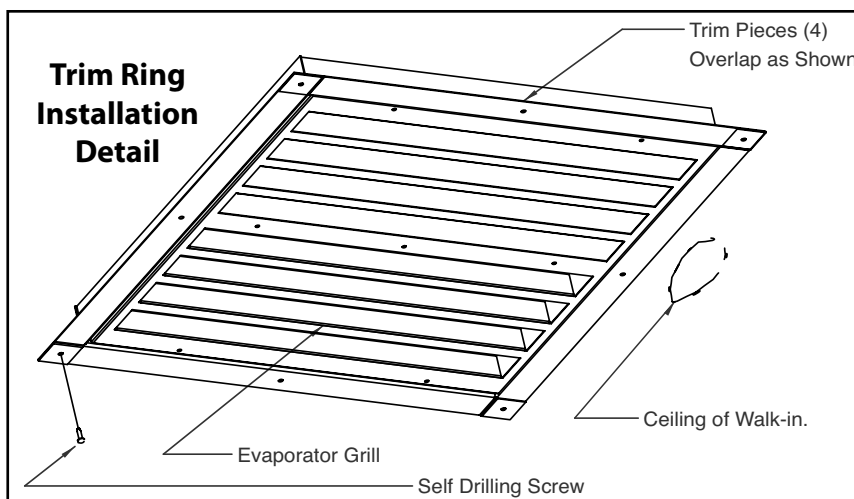

Inspection

1. Each shipment should be carefully checked against the bill of lading.
2. The shipping receipt should not be signed until all items listed on the bill of lading have been accounted for.
3. Check packaging for signs of damage.
4. Any shortage or damages should be immediately reported to the delivering carrier.
5. Damaged material becomes the delivering carrier's responsibility, and should not be returned to the manufacturer unless prior approval is given to do so.
6. When unpacking the system, care should be taken to prevent damage.
7. Avoid removing the shipping base until the unit has been moved to the final destination.
8. Complete warranty return card for each unit and mail to Heatcraft Refrigeration Products.

General Safety Information

1. Installation and maintenance to be performed only by licensed contractor.
2. Ensure that the structural integrity of the box can withstand the weight of the **PRO** (See page 2, Table 3 for unit weights).
3. Avoid contact with sharp edges and coil surfaces. They are a potential injury hazard. Wear gloves during moving and rigging.
4. Make sure all power sources are disconnected before any service work is done on units.

Table 4. Control Factory Default Settings

PTT Models	Temperature Set Points	Defrost Start Times	Defrost Duration (Maximum)	Drip Time	Fan Delay	Defrost Termination Set Point
Cooler Models All cabinet sizes	35°F	Every 3 hours of compressor run time	60 min.	–	–	38°F
Freezer Models Med. & Lg. cabinet	-10°F	4 / day	40 min.	2 min.	2 min.	65°F

The Outdoor PRO³ comes standard with the following additional components:

- Crankcase Heater
- Drain Line Heater
- Weather Hood
- Fan Cycling
(Pressure on 1 fan models, Pressure and Ambient on 2 fan models).

Standard Installation Procedure PTT Models

For outdoor use

1. Provide a 25" X 25" (medium cabinet) or 25" X 38.5" (large cabinet) opening in the roof of walk-in cooler or as specified by the panel manufacturer.
2. Apply silicone caulk around the perimeter of roof opening. Place the curb on roof of cooler. It is recommended that the curb be fastened to the roof panels using non-conductive bolts or insulating the bolt heads. Bolt heads should be countersunk or low profile to prevent contact with the PRO³ system. (See Figure 1, page 7) Check the top of the curb with a level. PRO³ units require a surface that is within 1° of level or better and no more than a 5/8" drop per 3 feet (17mm drop per meter).
3. Install the membrane onto the roof of the box and over the curb. Fasten to roof per panel manufacturer's instructions. The membrane material should be slit over the evaporator grill opening the flaps allowed to drape into the hole 2" - 4". (See Figure 2, page 7) Care should be taken during the membrane installation to prevent bunching or folding which could affect the gasket-to-curb sealing or trap rainwater adjacent to the curb.
4. Remove the weather hood from the PRO³ system. The compressor compartment cover(s) should be left in place during lifting/rigging.
5. Place PRO³ system onto curbing and center over opening in roof box. (See Figure 3, page 7)
6. It is recommended that the PRO³ system be secured to the curb with wood screws. Seal the screw heads as necessary to prevent moisture from entering beneath the membrane. Additional caulk may be applied around the perimeter of the evaporator box gasket. The compressor compartment should not be caulked.
7. Install trim pieces (if used) around the ceiling opening in cooler.

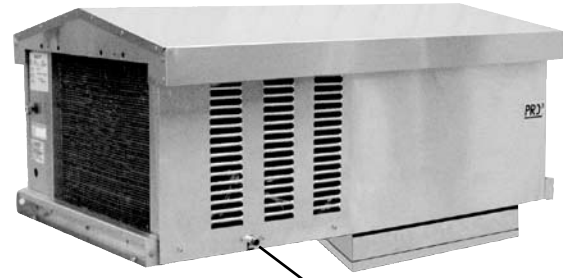

Condensate Drain
Outlet Location

8. Remove compressor compartment cover for access to electrical box.
9. Connect power wiring in accordance with all applicable building and electrical codes.
10. Reinstall condensing unit cover(s).
11. Reinstall the protective weather hood. (See Figure 4, page 7)
12. Apply power and check for proper operation.

Drain Line

A condensate drain outlet is located on the side of the compressor compartment. Field piping may be connected to the outlet provided it is adequately sloped and heated for freezing weather conditions. There is a drain line "P" trap located in the PTT unit.

General Safety information:

Do NOT lift the PRO³ by the weather hood.

This product is not designed to be transported while installed or operating.

PTT Models

Example Outdoor Curb Installation (Curb supplied by others)

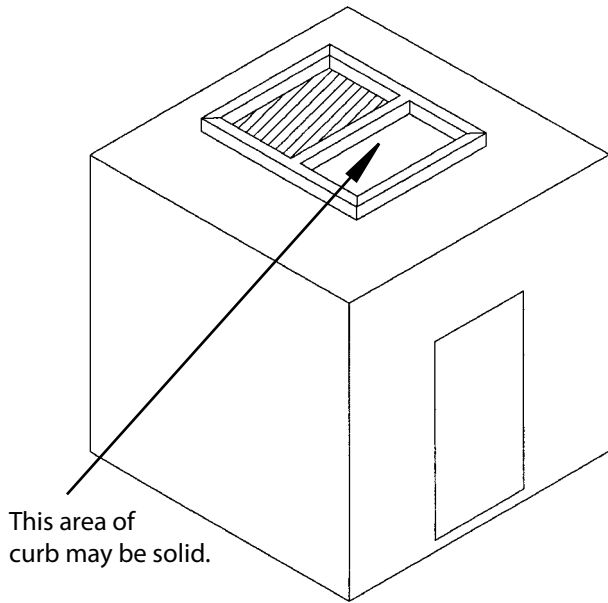

Figure 1. Curb placed on roof of walk-in cooler.

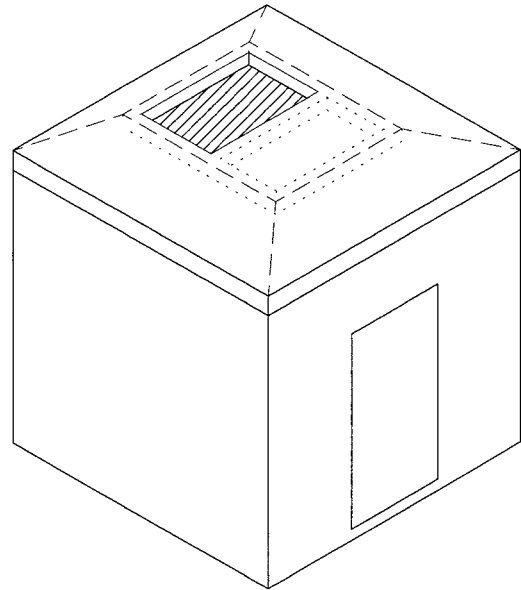

Figure 2. Roof membrane placed over curb.

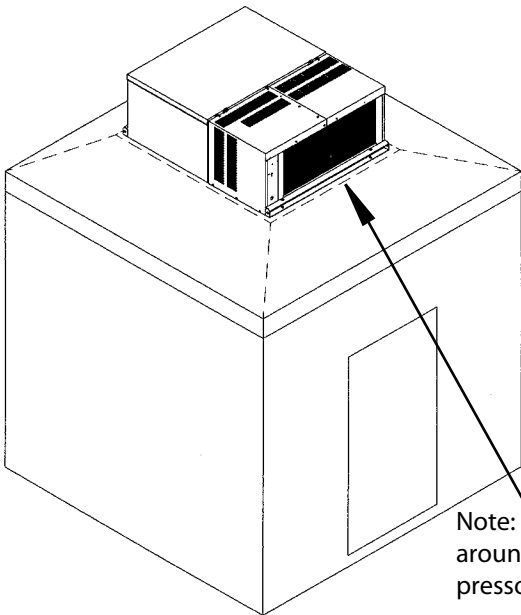

Figure 3. PTT unit placed on roof of walk-in color. (see rigging instructions).

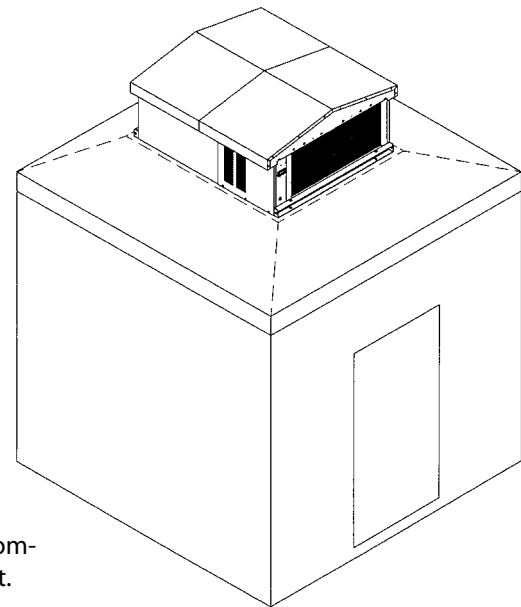

Figure 4. Weather hood installed after electrical service connection.

Medium and Large Cabinet Freezers

PRO Service Information

All PRO units are designed for maximum durability, reliability and simplicity. PRO comes to you ready for operation, fully charged and with all controls preset at the factory. The following information is provided as an aid in the event that service is required.

Maintenance

The evaporator section of a PRO system should be checked at least once for proper defrosting because the amount and pattern of frosting can vary greatly. The frost build-up is dependent on the temperature of the room, the type of product being stored, how often new product is brought into the room and percentage of time the door to the room is open. It may be necessary to periodically change the number of defrost cycles or adjust the duration of defrost.

PRO System Standard Maintenance Guidelines

After first year of operation and under normal usage, maintenance should cover the following items at least once every six months:

1. Check and tighten **ALL** electrical connections.
2. Check all wiring and insulators.
3. Check contactors for proper operation and for worn contact points.
4. Check all fan motors. Tighten motor mount bolts/ nuts and tighten fan set screws.
5. Clean the condenser coil surface.
6. Check the operation of the control system. Make certain all safety controls are operating properly.
7. Check that all defrost controls are functioning properly.
8. Clean the evaporator coil surface.
9. Clean the drain pan and check the drain pan and drain line for proper drainage.

Refrigeration Sequence of Operation

1. Power is provided to the temperature control, compressor contactor and cooler evaporator fans.
2. The temperature controller closes and energizes the compressor contactor, starting the compressor, evaporator and condenser fan(s).
3. When the system reaches the desired box temperature, the temperature control will de-energize the compressor contactor. Evaporator fans will continue to operate at this point.
4. When the fixture temperature rises above the set point and minimum off-time has elapsed, the temperature control will close and re-energize the compressor contactor.

Electric Defrost Sequence of Operation for Freezers

1. During normal operation, at the preset time intervals, the temperature/defrost control will de-energize the compressor contactor and evaporator fans and energize the defrost heaters. These functions are controlled through relays on the controller.
2. When the coil has defrosted fully and has reached the preset coil temperature (as sensed by the coil temperature sensor) the defrost heater de-energizes and the fan delay and drip sequences begin.

3. The temperature/defrost control energizes the compressor contactor, starting the compressor and condenser fan(s).
4. Freezer evaporator fans will be energized by the temperature/defrost control when the coil temperature reaches 35°F or fan delay time has elapsed.

Freezer Defrost Control - Medium & Large Cabinet

PRO freezer units come factory equipped with an electronic temperature/defrost control. There are 2 different models of electronic control used and it is important to determine which one is present on your unit before altering any factory settings. Please refer to the picture of the controller display on this page to determine the model used. Instructions for any necessary reprogramming are included in this manual on pages 8-10.

Dixell Electronic Controller

The Dixell XR-60CX and the Dixell XR-60C are fully configurable electronic refrigeration controllers. All parameter values are reprogrammable and are stored in the non-volatile memory.

The controllers use two levels of programming that can be accessed through the keypad. The first level is the user level. It gives access to six settings; temp. differential, defrost cycle intervals, defrost termination temperature, draining time, defrost fan delay, and fan stop temperature.

The second level is the service level. It allows access to all other parameters. It is recommended that changes in this level be made only by a qualified technician.

Front Panel Commands



XR-60CX Controller



XR-60C Controller

USE OF LEDs

Each LED function is described in the following table.

LED	LED MODE	FUNCTION
	ON	Compressor enabled
	Flashing	-Programming Phase (flashing with) - Anti-short cycle delay enabled
	ON	Defrost enabled
	Flashing	- Programming Phase (flashing with) - Drip time in progress
	ON	Fans enabled
	Flashing	Fans delay after defrost in progress (60CX only)
	ON	A temperature alarm occurred

MAIN FUNCTIONS

HOW TO SEE THE SETPOINT

-  1. Push and immediately release the **SET** key: the display will show the Set point value.

HOW TO CHANGE THE SETPOINT

1. Push the **SET** key for more than 2 seconds to change the Set point value;
2. The value of the set point will be displayed and the LED starts blinking;
3. To change the Set value push the **UP** or **DOWN** arrows within 10s.
4. To memorise the new set point value push the **SET** key again or wait 10s.

HOW TO START A MANUAL DEFROST

-  Push the **DEF** key for more than 2 seconds and a manual defrost will start.

HOW TO CHANGE A PARAMETER VALUE

To change the parameter's value operate as follows:

1. Use "**UP**" or "**DOWN**" to change its value.
2. Press "**SET**" to store the new value and move to the following parameter.

To exit: Press **SET + UP** or wait 15s without pressing a key.

NOTE: the set value is stored even when the procedure is exited by waiting the time-out to expire.

THE HIDDEN MENU

The hidden menu Includes all the parameters of the instrument.

HOW TO ENTER THE HIDDEN MENU

-  1. Enter the Programming mode by pressing the Set + **DOWN** key for 3s (LED 1 and start blinking).
2. When a parameter is displayed keep pressed the Set + **DOWN** for more than 7s. The Pr2 label will be displayed immediately followed from the HY parameter.

NOW YOU ARE IN THE HIDDEN MENU.

3. Select the required parameter.
4. Press the "**SET**" key to display its value (Now only the LED is blinking).
5. Use **UP** or **DOWN** to change its value.
6. Press "**SET**" to store the new value and move to the following parameter.

To exit: Press **SET + UP** or wait 15s without pressing a key.

NOTE: the set value is stored even when the procedure is exited by waiting the time-out to expire.

HOW TO SEE THE ALARM DURATION AND MAX (MIN) TEMPERATURE

If the alarm LED is on, an alarm has taken place.

To see the kind of alarm, the max (min) reached temperature and alarm duration do as follows:v

1. Push the Up or Down key.
2. On the display the following message is shown: "**HAL**" for high temperature alarm ("**LAL**" for the minimum alarm), followed by the **Maximum (minimum) temperature**. Then the "**tiM**" (**tiMe**) message is displayed, followed by the "**Duration**" in h.mm.
3. Then the instrument displays the temperature once again.

NOTE1: if an alarm is still occurring the "**tim**" shows the partial duration.

NOTE2: the alarm is recorded when the temperature come back to normal values

HOW TO RESET A RECORDED ALARM OR ONE THAT IS STILL OCCURRING

1. Hold the SET key pressed for more than 3s, while the recorded alarm is displayed. (the rSt message will be displayed)
2. To confirm the operation, the "rSt" message starts blinking and the normal temperature will be displayed

DEFAULT PARAMETER SETTINGS

Label	Characteristic	Description	Menu/User Level	Possible Settings	DEFAULT SETTINGS		
					Low Temp.	Medium Temp.	High Temp.
REGULATION							
SEt	Set Point			LS ~ US	-10	34	38
Hy	Differential	(0,1 ÷ 25,5°C / 1÷255 °F) Intervention differential for set point. Compressor Cut IN is Set Point + differential (Hy). Compressor Cut OUT is when the temperature reaches the set point	Pr1	1~ 45	3	3	3
LS	Minimum set point	(- 50°C÷SET/-58°F÷SET): Sets the minimum value for the set point..	Pr2	-67 ~ SET	-23	25	33
US	Maximum set point	(SET÷110°C/ SET÷230°F). Set the maximum value for set point.	Pr2	SET ~ 302F	37	40	45
Ot	Thermostat probe calibration	(-12.0÷12.0°C; -120÷120°F) allows to adjust possible offset of the thermostat probe	Pr2	-21~21	0	0	0
OdS	Outputs activation delay at start up	(0÷255min) This function is enabled at the initial start up of the instrument and inhibits any output activation for the period of time set in the parameter	Pr2	0 ~ 255 minutes	0	0	0
AC	Anti-short cycle delay	(0÷50 min) minimum interval between the compressor stop and the following restart	Pr2	0 ~ 50 minutes	4	4	4
COF	Compressor OFF time with faulty probe	(0÷255 min) time during which the compressor is OFF in case of faulty thermostat probe. With COF=0 compressor is always active	Pr2	0 ~ 255 minutes	6	6	6

DISPLAY							
CF	Temperature measurement unit	°C=Celsius; °F=Fahrenheit. WARNING: When the measurement unit is changed the SET point and the values of the parameters Hy, LS, US, Ot, ALU and ALL have to be checked and modified if necessary	Pr2	°C = Celsius °F =Fahrenheit	°F	°F	°F
DEFROST							
tdF	Defrost type	EL = electrical heater; in = hot gas	Pr2	EL = electric defrost / in = hot gas defrost	EL	EL	EL
dtE	Defrost termination temperature	(-50÷50 °C/ -58÷122°F) (Enabled only when EdF=Pb) sets the temperature measured by the evaporator probe, which causes the end of defrost	Pr1	-58~122	65	65	38
ldF	Interval between defrost cycles	(0÷120h) Determines the time interval between the beginning of two defrost cycles	Pr1	0 ~ 120 hours	6	6	6
MdF	(Maximum) length for defrost	(0÷255min) When P2P = n, (not evaporator probe: timed defrost) it sets the defrost duration, when P2P = y (defrost end based on temperature) it sets the maximum length for defrost	Pr2	0 ~ 255 minutes	40	40	60
Fdt	Drip time	(0÷120 min) time interval between reaching defrost termination temperature and the restoring of the control's normal operation. This time allows the evaporator to eliminate water drops that might have formed due to defrost	Pr1	0 ~ 255 minutes	2	2	0
FANS (XR60CX ONLY)							
Fnd	Fans delay after defrost	(0÷255min) Interval between end of defrost and evaporator fans start	Pr1	0 ~ 255 minutes	2	2	Not Applicable
Fct	Temperature differential avoiding short cycles of fans	(0÷59°C; Fct=0 function disabled). If the difference of temperature between the evaporator and the room probes is more than the value of the Fct parameter, the fans are switched on	Pr2	0~90	10	10	Not Applicable
FSt	Fans stop temperature	(-50÷50°C/122°F) setting of temperature, detected by evaporator probe, above which fans are always OFF	Pr1	-58~122	35	35	Not Applicable
ALARMS							
ALC	Temperature alarms configuration	(Ab; rE) Ab= absolute temperature: alarm temperature is given by the ALL or ALU values. rE = temperature alarms are referred to the set point. Temperature alarm is enabled when the temperature exceeds the "SET+ALU" or "SET-ALL" values	Pr2	rE = relative to set point Ab = absolute	Ab	Ab	Ab
ALU	MAXIMUM temperature alarm	(SET÷110°C; SET÷230°F) when this temperature is reached the alarm is enabled, after the "ALd" delay time	Pr2	ALL~ 302	38	50	50
ALL	Minimum temperature alarm	-50.0 ÷ SET°C; -58÷230°F when this temperature is reached the alarm is enabled, after the "ALd" delay time	Pr2	-58~ ALu	-25	15	30

ALARM SIGNALS

Message	Cause	Outputs
"P1"	Room probe failure	Compressor output according to par. "Con" and "COF"
"P2"	Evaporator probe failure	Defrost end is timed
"HA"	Maximum temperature alarm	Outputs unchanged.

Message	Cause	Outputs
"LA"	Minimum temperature alarm	Outputs unchanged.
"dA"	Door open	Compressor and fans restarts
"EA"	External alarm	Output unchanged.

Reprinted with permission from Dixell.

All Cooler Models

Cooler Defrost Control

Cooler units utilize an electronic temperature control. The temperature may be adjusted by setting the dial. This control is preset to provide 3 hours of compressor run time between defrost cycles. Defrosts are temperature terminated and cannot be reprogrammed. The temperature control is programmed for minimum on cycle of one minute and minimum off cycle of four minutes.

Air Defrost Sequence of Operation for Coolers

Air defrost units are preprogrammed for 3 hours of compressor run time between defrosts. These periods are not reprogrammable. After 3 hours, the temperature control will turn the compressor off. When the coil temperature reaches 38°F, the control will terminate the defrost cycle.

Room Thermostat Settings:

- Approximate dial settings of control
 - 0 = Unit off (not an electrical disconnect)
 - 1 = 52°F (11°C)
 - 2 = 49°F (9°C)
 - 3 = 45°F (7°C)
 - 4 = 41°F (5°C)
 - 5 = 38°F (3°C)
 - 6 = 34°F (1°C)

NOTE: If power is interrupted to the unit during the refrigeration off-cycle (system at temperature setpoint, compressor off), the thermostat will initiate an extra defrost period approximately one hour after power is restored.

Maintenance

The evaporator section of a PRO³ system should be checked at least once for proper defrosting because the amount and pattern of frosting can vary greatly. The frost build-up is dependent on the temperature of the room, the type of product being stored, how often new product is brought into the room and percentage of time the door to the room is open.

PRO³ System Standard Maintenance Guidelines

After first year of operation and under normal usage, maintenance should cover the following items at least once every six months:

1. Check and Tighten **ALL** electrical connections.
2. Check all wiring and insulators.
3. Check contactors for proper operation and for worn contact points.
4. Check all fan motors. Tighten motor mount bolts/nuts and tighten fan set screws.
5. Clean the condenser coil surface.
6. Check the operation of the control system. Make certain all safety controls are operating properly.
7. Check that all defrost controls are functioning properly.
8. Clean the evaporator coil surface.
9. Clean the drain pan and check the drain pan and drain line for proper drainage.

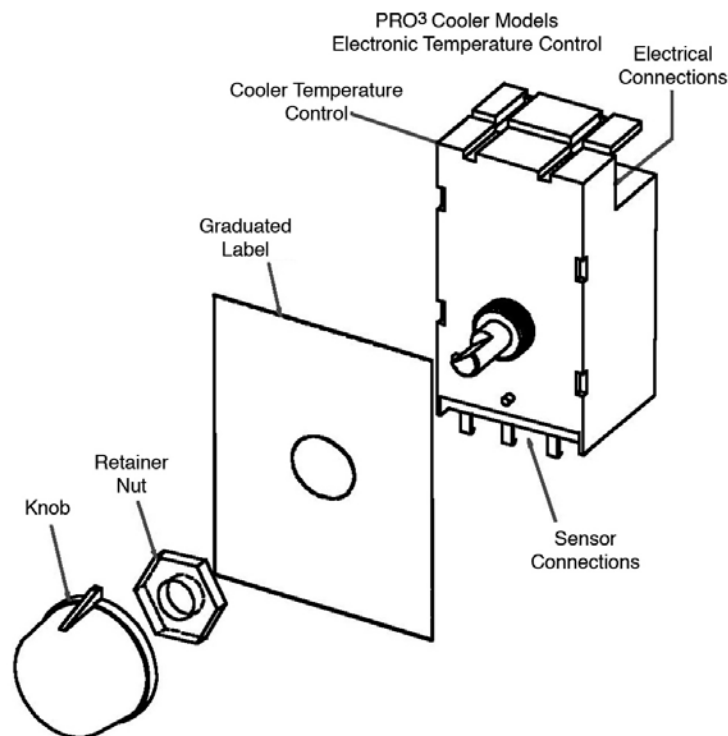
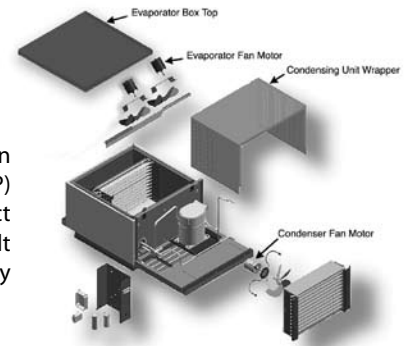

Table 5. PRO³ System Troubleshooting Chart

PROBLEM	POSSIBLE CAUSES	POSSIBLE CORRECTIVE STEPS
Compressor will not run	1. Main switch open.	1. Close switch.
	2. Fuse blown.	2. Check electrical circuits and motor winding for shorts or grounds. Investigate for possible overloading. Replace fuse after fault is corrected.
	3. Thermal overloads tripped.	3. Overloads are automatically reset. Check unit closely when unit comes back on line.
	4. Defective contactor or coil.	4. Repair or replace.
	5. System shut down by safety devices.	5. Determine type and cause of shutdown and correct it before resetting safety switch.
	6. No cooling required.	6. None. Wait until calls for cooling.
	7. Motor electrical trouble.	7. Check motor for open windings, short circuit or burn out.
	8. Loose wiring.	8. Check all wire junctions. Tighten all terminal screws.
Compressor noisy or vibrating	1. Flooding of refrigerant into crankcase.	1. Check setting of expansion valves.
	2. Worn compressor.	2. Replace.
High discharge pressure	1. Non-condensables in system.	1. Remove the non-condensables.
	2. Fan not running.	2. Check electrical circuit. Replace if motor fails.
	3. Dirty condenser coil.	3. Clean.
	4. System overcharged with refrigerant.	4. Reclaim refrigerant and recharge proper amount.
Low discharge pressure	1. Insufficient refrigerant in system.	1. Check for leaks. Repair and add charge.
	2. Low suction pressure.	2. See corrective steps for low suction pressure.
High suction pressure	1. Excessive load.	1. Reduce load or add additional equipment.
	2. Expansion valve overfeeding.	2. Check remote bulb. Regulate superheat.
Low suction pressure	1. Lack of refrigerant.	1. Check for leaks. Repair and add charge (see refrigerant charge chart).
	2. Evaporator dirty or iced.	2. Clean.
	3. Expansion valve malfunctioning.	3. Check and reset for proper superheat.
	4. Condensing temperature too low.	4. Check ambient temp, 50°F to 100°F.
Compressor thermal protector switch open	1. Operating beyond design conditions.	1. Add equipment so that conditions are within allowable limits.
	2. Dirty condenser coil.	2. Clean coil.
	3. Overcharged system.	3. Reduce charge (see refrigerant charge).
Fan(s) will not operate	1. Main switch open.	1. Close switch.
	2. Blown fuses.	2. Replace fuses. Check for short circuits or overload conditions.
	3. Defective motor.	3. Replace motor.
	4. Defective defrost control.	4. Replace defective component.
	5. Unit in defrost cycle.	5. Wait for completion of cycle.
	6. Coil does not get cold enough to reset thermostat	6. Adjust fan delay setting of control. See Defrost Section page 8.
Room temperature too high	1. Control cut out set too high.	1. Adjust control.
	2. Superheat too high.	2. Adjust thermal expansion valve.
	3. System low on refrigerant.	3. Add refrigerant. See refrigerant charge chart.
	4. Coil iced-up.	4. Manually defrost coil. Check defrost controls for malfunction.
Ice accumulating on ceiling around evaporator and/or on fan guards' venturi or blades	1. Defrost duration is too long.	1. Adjust defrost termination temp on control. See page 8.
	2. Fan delay not delaying fans after defrost period.	2. Adjust fan delay setting or replace bad sensor.
	3. Defective defrost control or sensor.	3. Replace defective control or sensor. See page 10 error codes.
	4. Too many defrosts.	4. Adjust number of defrosts.
Coil not clearing of frost during defrost cycle.	1. Coil temperature not getting above freezing point during defrost.	1. Check heater operation.
	2. Not enough defrost cycles per day.	2. Adjust control for more defrost cycles.
	3. Defrost cycle too short.	3. Adjust defrost control, defrost duration setting.
	4. Defective defrost control or sensor.	4. Replace defective component. See page 10 error codes.
Ice accumulating in drain pan	1. Defective heater.	1. Replace heater.
	2. Unit not installed properly (out of level)	2. Check and adjust if necessary. See pages 7, 8.
	3. Drain line plugged.	3. Clean drain line.
	4. Defective control.	4. Replace defective component.



Right source. Right parts. Right now.

InterLink™ is your link to a complete line of dependable and certified commercial refrigeration parts, accessories and innovative electronic controls for all Heatcraft Refrigeration Products (HRP) equipment. At InterLink, we provide our wholesalers with a comprehensive selection of product solutions and innovative technologies for the installed customer base. And every product is built to ensure the same high performance standards with which all HRP brands are built — backed by a dedicated team to serve every customer need, delivering at the best lead times in the industry.

Dependable. Versatile. Courteous.

Finally, one simple source for all your replacement needs from a name you can trust.

For parts, please visit www.interlinkparts.com or call (800) 686-7278.

Part Description	Part Number	Coolers						Freezers							
		PTT047H2B	PTT063H2B	PTT072H2B	PTT099H2B	PTT099H2C	PTT128H2B	PTT128H2C	PTT021L6B	PTT031L6B	PTT044L6B	PTT052L6B	PTT052L6C	PTT069L6B	PTT069L6C
Fan Blades															
Evaporator	22901901	1	2	2	3	3	3	3	1	2	2	3	3	3	3
Condenser	22900701	1	1	1	2	2	2	2	1	1	1	2	2	2	2
Fan Motors															
208/230V Evaporator	25307801**	1	2	2	3	3	3	3	1	2	2	3	3	3	3
208/230V Condenser	25307801	1	1	1	2	2	2	2	1	1	1	2	2	2	2
Evap. Fan Motor Bracket	4000104	1	2	2	3	3	3	3	1	2	2	3	3	3	3
Cond. Fan Motor Bracket	23103301	1	1	1	2	2	2	2	1	1	1	2	2	2	2
Contactors															
25A, 208-240V	2259996					1		1					1		1
20A, 230V	034915200	1	1	1	1		1		1	1	1	1		1	
Temperature Control															
Freezer Defrost/Temp Control Kit 208/230V*	89814701								1	1	1	1	1	1	1
Temp Control Cooler 208/240V Kit*	89814601	1	1	1	1	1	1	1							
Heater Limit Thermostat	5708L								1	1	1	1	1	1	1
Defrost Heaters															
230V Defrost Heaters	4312F								3	3	3				
230V Defrost Heaters	4313F											3	3	3	3
Outdoor Parts															
Fan Pressure Control	28917301	1	1	1	1	1	1	1	1	1	1	1	1	1	1
Fan Temperature Control	5521R				1	1	1	1				1	1	1	1
Drain Line Heater	24753401	1	1	1											
Drain Line Heater T'stat	28917401	1	1	1	1	1	1	1	1	1	1	1	1	1	1
Weather Hood Medium	50047901	1	1	1					1	1	1				
Weather Hood Large	50047801				1	1	1	1				1	1	1	1

*Kits include control, sensors, mounting hardware and instructions.

**PSC motor option (H designation on end of model name): part 25307801 = 25308601, part 25307701 = 25308501, part 25303201 = 25399201, part 25300101 = 25308501. Contact InterLink Parts at 800-686-7278.

Whenever possible, replacement parts are to be obtained from one of our local authorized wholesalers. Replacement parts which are covered under the terms of the warranty statement on the back cover of this manual, will be reimbursed for total part cost only. The original invoice from the parts supplier must accompany all warranty claims for replacement part reimbursement. Heatcraft Refrigeration Products reserves the right to adjust the compensation amount paid on any parts submitted for warranty reimbursement when a parts supplier's original invoice is not provided with a claim.

PRO³ Medium and Large Cabinet Models Wiring. 208-230/1/60 voltages.

Cooler - Air Defrost Systems - Single Phase

Diagram 1. Wiring Diagram for PRO³ System, Air Defrost 208-230/1/60 (B): Models PTT047H2B, PTT063H2B, PTT072H2B, PTT099H2B, and PTT128H2B.

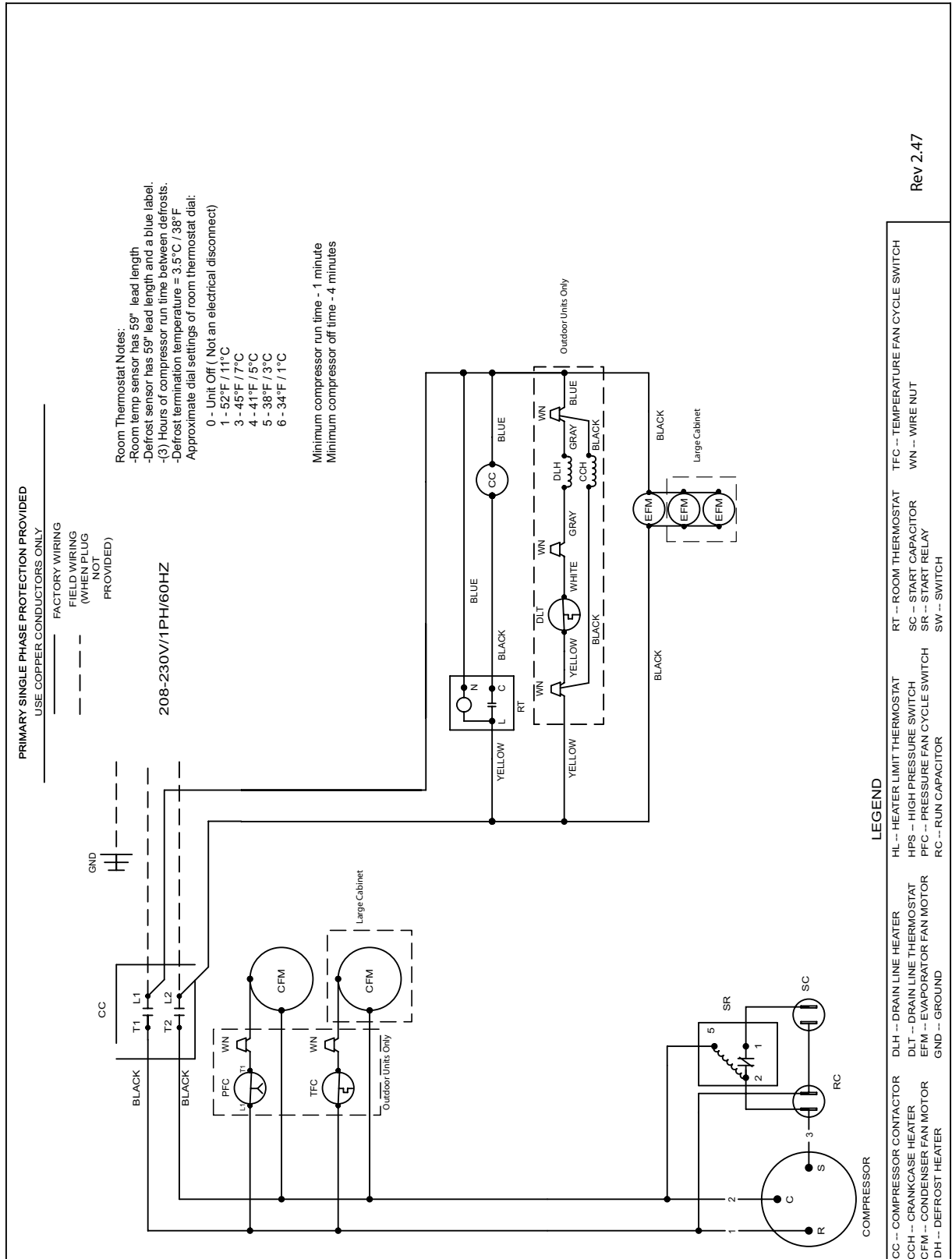

Rev 2.47

**PRO³ Medium and Large Cabinet Models Wiring. 208-230/1/60 voltages
Indoor and Outdoor Models with Dixell XR-60C Controller**

Freezer - Electric Defrost Systems - Single Phase

Diagram 2. Wiring Diagram for PRO³ System, Electric Defrost 208-230/1/60 (B): Models PTT021L6B, PTT031L6B, PTT044L6B, PTT052L6B, and PTT069L6B.

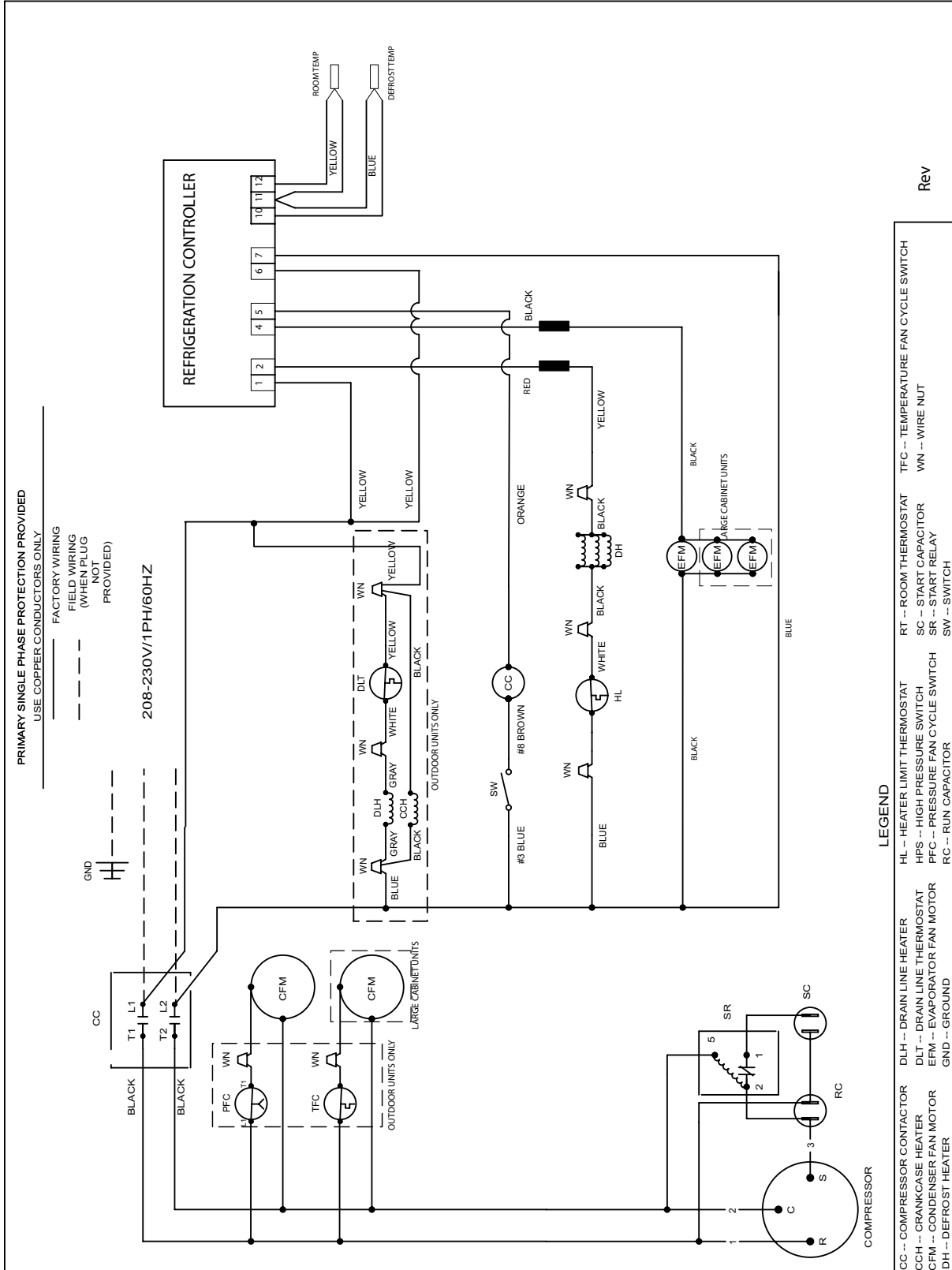

PRO³ Medium and Large Cabinet Models Wiring. 208-230/1/60 voltages
Indoor and Outdoor Models with Paragon Controller

Diagram 3. Wiring Diagram for PRO³ System, Electric Defrost 208-230/1/60 (B): Models PTT021L6B, PTT031L6B, PTT044L6B, PTT052L6B and PTT069L6B.

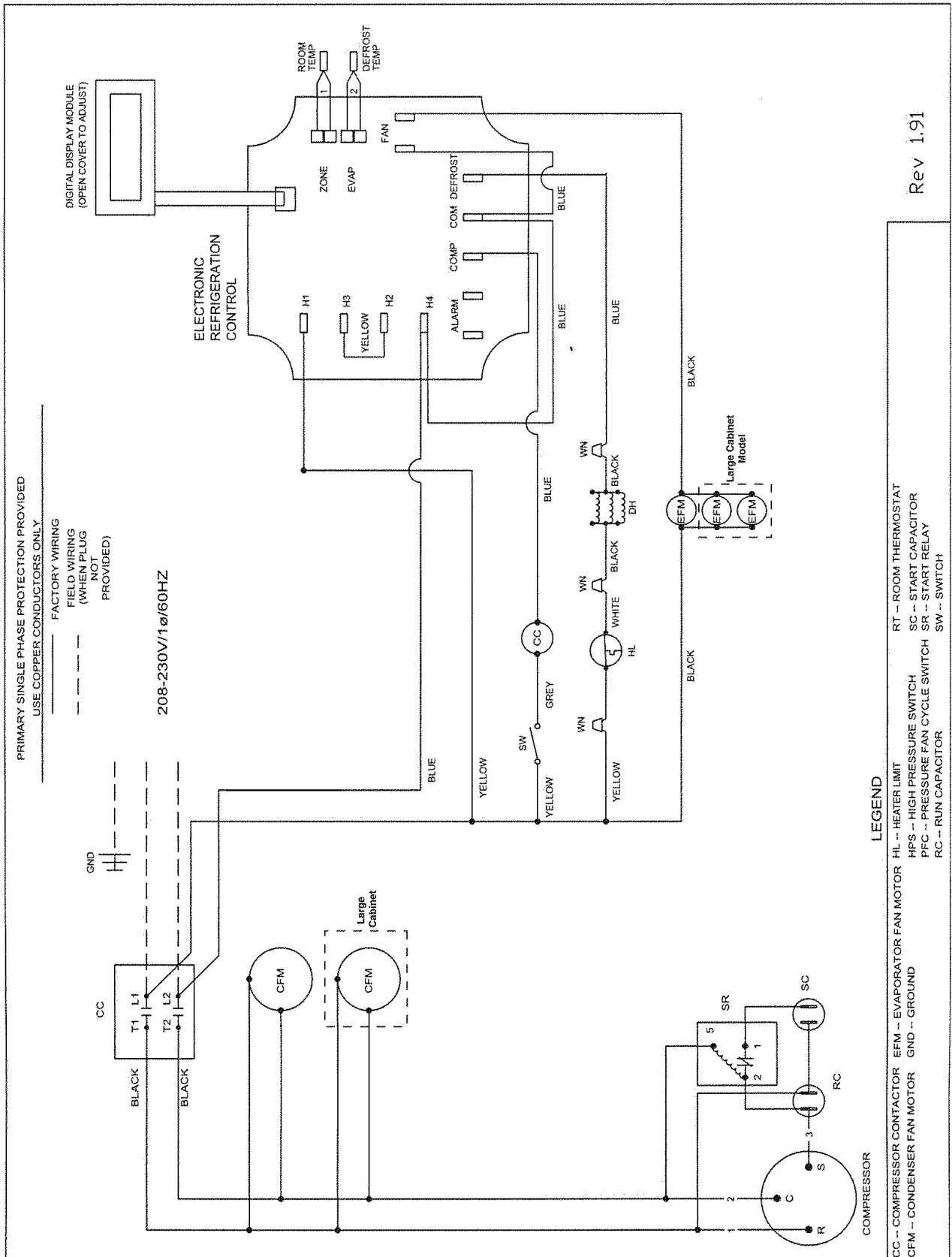

Rev 1.91

Cooler - Air Defrost Systems - Three Phase

Diagram 4. Wiring Diagram for PRO³ System, Air Defrost 208-230/3/60 (C): Models PTT099H2C and PTT128H2C.

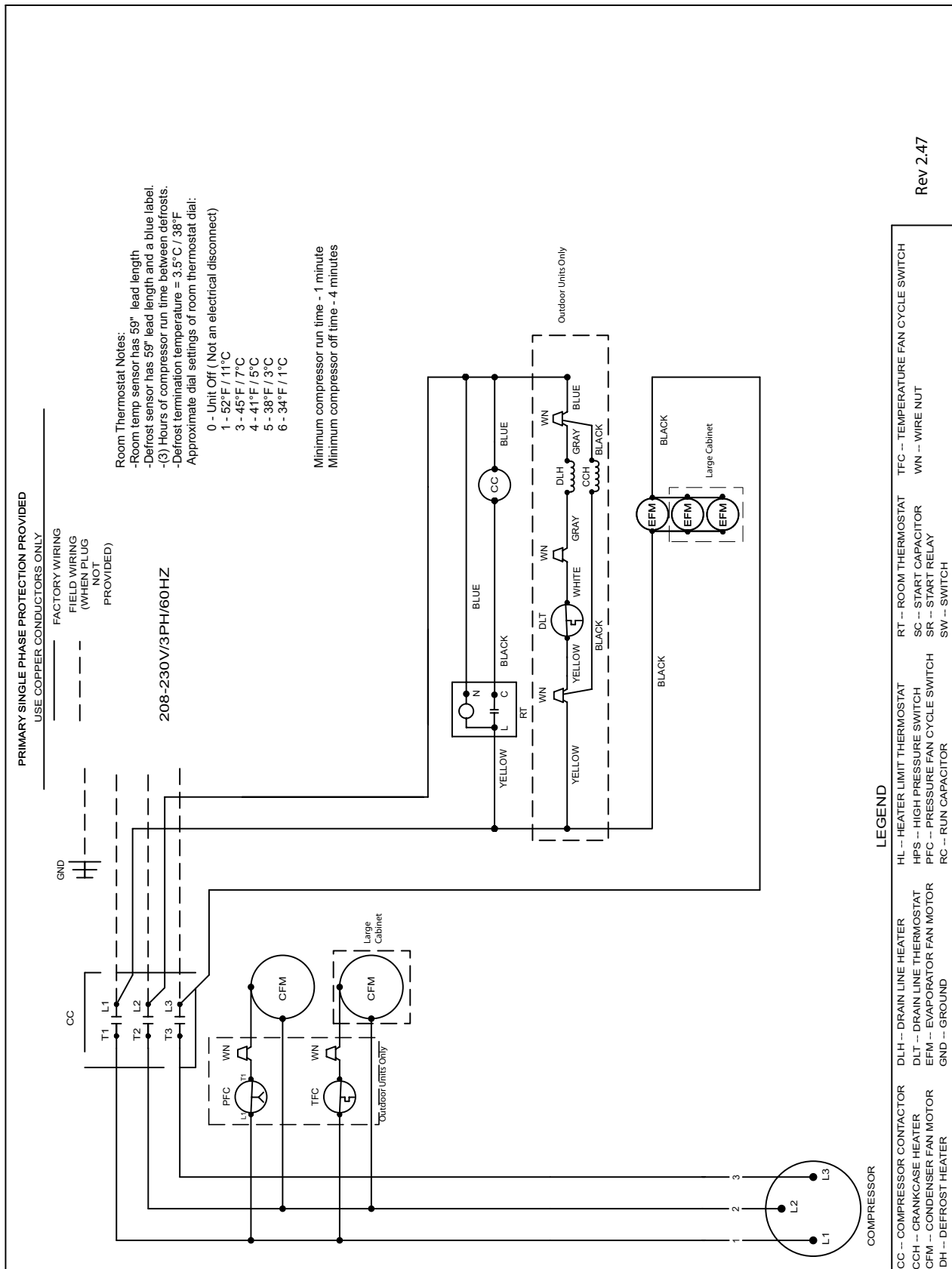

Rev 2.47

**PRO³ Large Cabinet Models Wiring. 208-230/3/60 voltage
Indoor and Outdoor Models with Dixell XR-60C Controller**

Freezer - Electric Defrost Systems - Three Phase

Diagram 5. Wiring Diagram for PRO³ System, Electric Defrost 208-230/3/60 (C): Models PTT052L6C and PTT069L6C only.

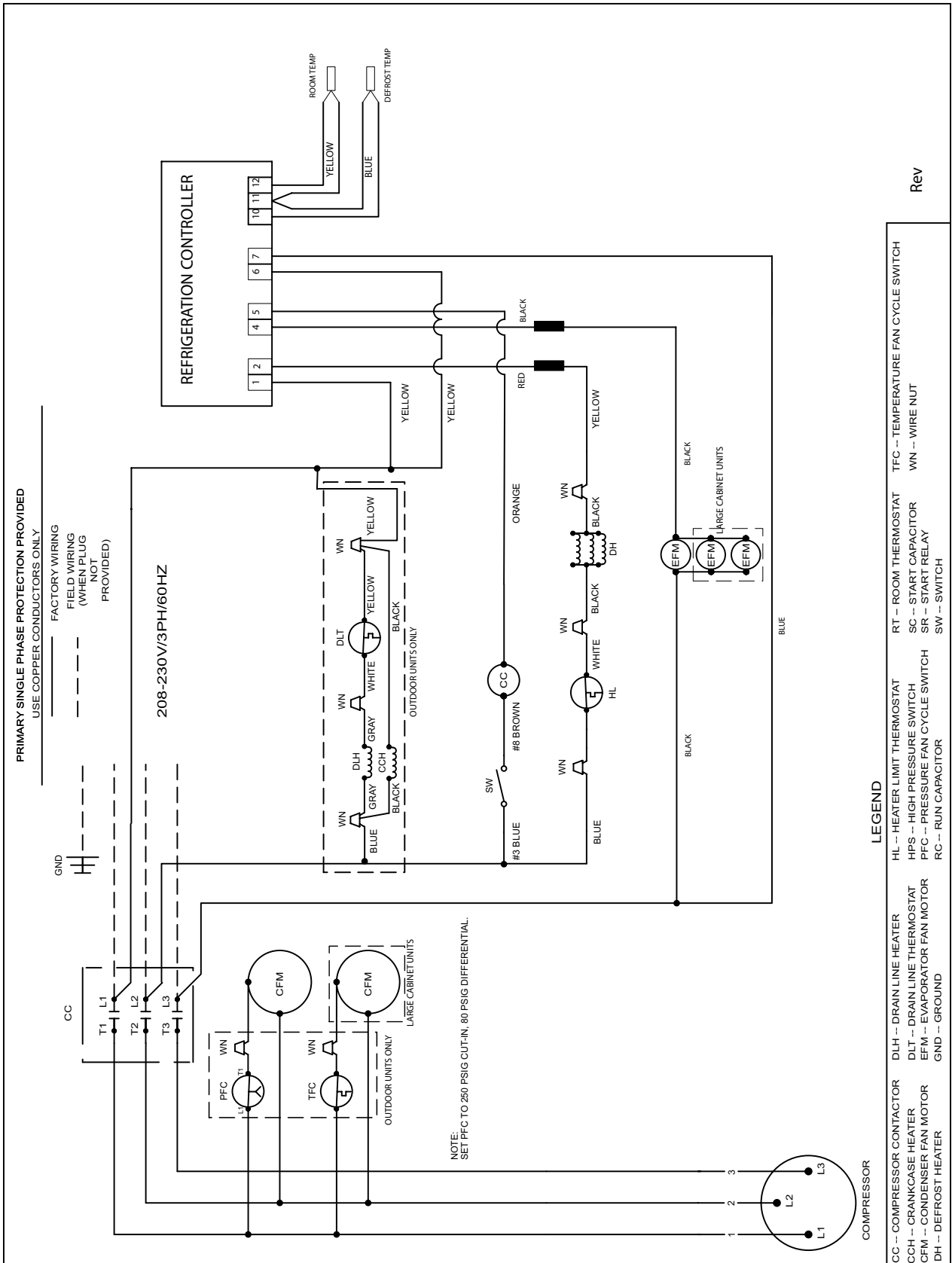

**PRO³ Large Cabinet Models Wiring. 208-230/3/60 voltage
Indoor and Outdoor Models with Paragon Controller**

Freezer - Electric Defrost Systems - Three Phase

Diagram 6. Wiring Diagram for PRO³ System, Electric Defrost 208-230/3/60 (C): Models PTT052L6C and PTT069L6C only.

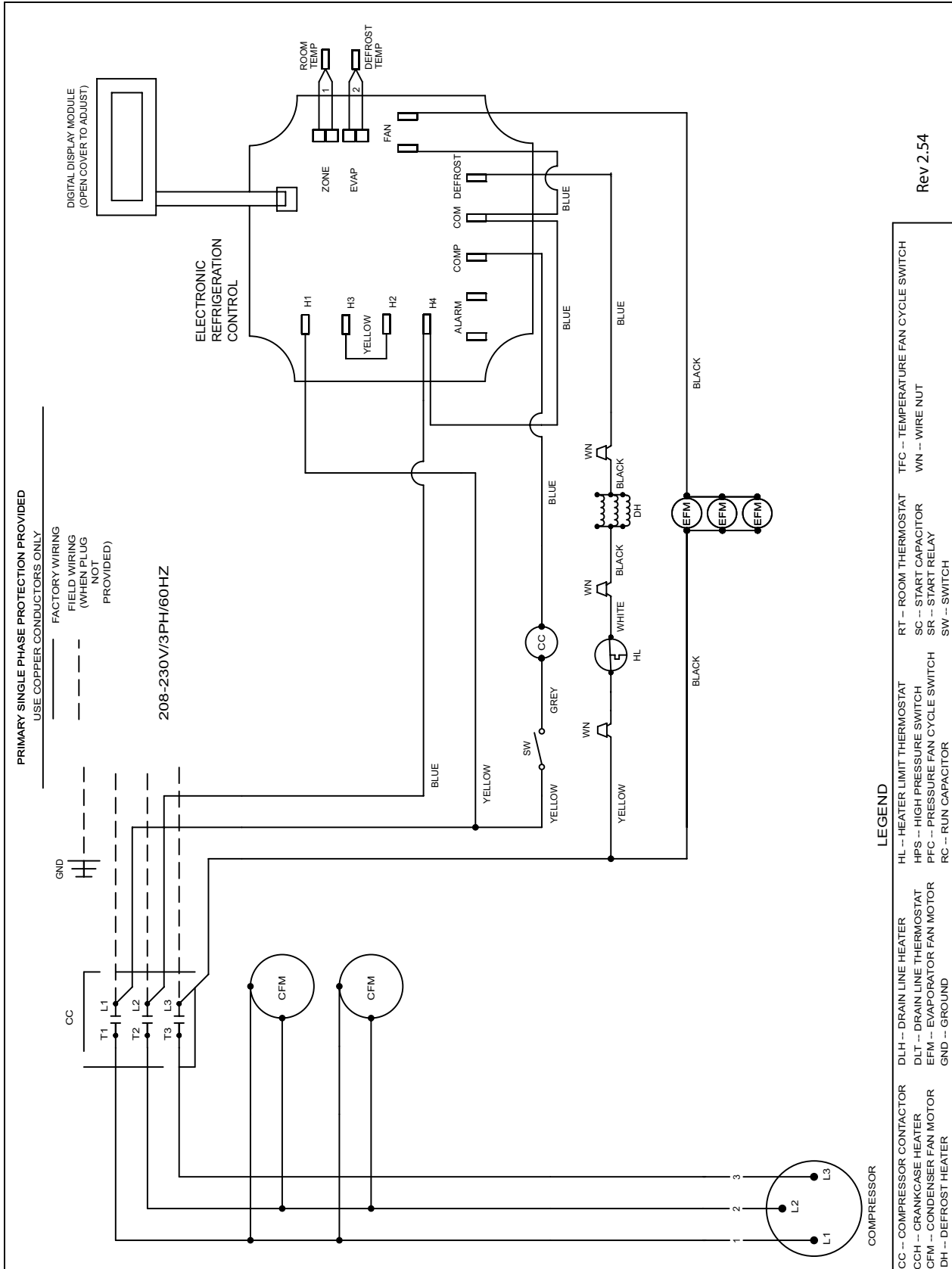

Rev 2.54

Warranty Statement

Heatcraft Refrigeration Products LLC warrants to its direct purchasers that the **PRO** product, except Service Parts, manufactured by Heatcraft Refrigeration Products LLC shall be of a merchantable quality, free of defects in material or workmanship, under normal use and service for a period of two (2) years from date of original installation, or thirty (30) months from date of shipment by Heatcraft Refrigeration Products LLC, whichever first occurs. Service Parts, for product out of original warranty, should be so warranted for a period of twelve (12) months from date of shipment. Any product covered by this order found to Heatcraft Refrigeration Products LLC's satisfaction to be defective upon examination at Heatcraft Refrigeration Products LLC's factory will, at Heatcraft Refrigeration Products LLC's option, be repaired or replaced and returned to Buyer via lowest common carrier, or Heatcraft Refrigeration Products LLC may at its option grant Buyer a credit for the purchase price of the defective article. Upon return of a defective product to Heatcraft Refrigeration Products LLC's plant, freight prepaid, by Buyer, correction of such defect by repair or replacement, and return freight via lowest common carrier, shall constitute full performance by Heatcraft Refrigeration Products LLC of its obligations hereunder.

Hermetic compressors furnished by Heatcraft Refrigeration Products LLC are subject to the standard warranty terms set forth above, except that motor compressor replacements or exchanges shall be made through the nearest authorized wholesaler of the motor compressor manufacturer (not at Heatcraft Refrigeration Products LLC's factory) and no freight shall be allowed for transportation of the motor compressor to and from the wholesaler. The replacement motor compressor shall be identical to the model of the motor compressor being replaced. Additional charges which may be incurred throughout the substitution of other than identical replacements are not covered by this warranty.

The foregoing is in lieu of all other warranties, express or implied, notwithstanding the provisions of the uniform commercial code, the Magnuson-Moss Warranty-Federal Trade Commission Improvement Act, or any other statutory or common law, federal or state.

Heatcraft Refrigeration Products LLC makes no warranty expressed or implied, of fitness for any particular purpose, or of any other nature whatsoever, with respect to products manufactured or sold by Heatcraft Refrigeration Products LLC hereunder, except as specifically set forth above and on the face hereof. It is expressly understood and agreed that Heatcraft Refrigeration Products LLC shall not be liable to buyer, or any customer of Buyer, for direct or indirect, special, incidental, consequential or penal damages, or for any expenses incurred by reason of the use or misuse by Buyer or third parties of said products. To the extent said products may be considered "Consumer Products," as defined in Section 101 of the Magnuson-Moss warranty-Federal Trade Commission Improvement Act, Heatcraft Refrigeration Products LLC makes no warranty of any kind, express or implied, to "Consumers," except as specifically set forth above and on the face hereof.

This equipment is designed to operate properly and produce the rated capacity when installed in accordance with good refrigeration industry practices.

The following conditions should be adhered to when installing this unit to maintain the manufacturers warranty:

- (a) The power supply to the unit must meet the following conditions:
 - A. Three phase voltages must be +/- 10% of nameplate ratings. Single phase must be within +10% or -5% of nameplate ratings.
 - B. Phase imbalance cannot exceed 2%.
- (b) All control and safety switch circuits must be properly connected according to the wiring diagram.
- (c) The factory installed wiring must not be changed without written factory approval.

Optional Three-Year Extended Compressor Warranty

The Equipment Dealer may purchase for the Owner at the time of the original invoice of the equipment a Three-Year Limited Replacement Compressor Warranty. This entitles the owner to be reimbursed for the cost of a replacement compressor, during the third through fifth year of the life of the compressor.

The warranty program functions similarly to the standard warranty offered. When a compressor failure occurs and the unit is exchanged "over the counter" at the authorized wholesaler outlet a salvage credit is issued along with the invoice for the new compressor. Return copies of both the credit and invoice to the Equipment Dealer along with the model and serial number of the condensing unit. The Equipment Dealer will process this claim with the Manufacturer and subsequently reimburse the Owner for the cost of the new compressor.

This warranty covers the actual compressor only and does not extend to any labor, trip charges, crane rental, taxes or additional parts, refrigerant or processing/handling charges required to make the unit operational.

Since product improvement is a continuing effort,
we reserve the right to make changes in specifications without notice.

2175 West Park Place Blvd. • Stone Mountain, GA 30087
(800) 321-1881 • Fax: (770) 465-5990 • www.heatcrafttrpd.com



H-IM-82B-0708

Free Manuals Download Website

<http://myh66.com>

<http://usermanuals.us>

<http://www.somanuals.com>

<http://www.4manuals.cc>

<http://www.manual-lib.com>

<http://www.404manual.com>

<http://www.luxmanual.com>

<http://aubethermostatmanual.com>

Golf course search by state

<http://golfingnear.com>

Email search by domain

<http://emailbydomain.com>

Auto manuals search

<http://auto.somanuals.com>

TV manuals search

<http://tv.somanuals.com>