

R7184A,B,P,U Interrupted Electronic Oil Primary

INSTALLATION INSTRUCTIONS

APPLICATION

The R7184A,B,P,U Interrupted Electronic Oil Primary is a line voltage, safety rated, interrupted ignition oil primary control for residential oil fired burners used in boilers, forced air furnaces and water heaters. The R7184A,B,P,U used with a cad cell flame sensor, operates an oil burner and optional oil valve. The primary controls fuel oil, senses flame, controls ignition spark and notifies a remote alarm circuit when in lockout.

The R7184 can be used with both hydronic and forced air systems. When used with hydronic systems, line voltage switching Aquastat® Controllers normally provide for the starting and stopping of the combustion sequences. With forced air systems, both mechanical and electronic low voltage thermostats control the starting and stopping of the combustion process.

Some hydronic and forced air systems now require a delayed valve-on and burner motor-off delay. The R7184 operates an oil valve that prevents the flow of oil when the burner motor is running prior to combustion (delayed valve-on) and when the burner motor is running after combustion (burner motor-off delay).

The R7184 models are intended for use only on oil burning appliances which do not require prepurge and post-purge as a safety related function as defined in UL 296. The valve-on delay and burner motor-off delay in this control are intended only to help establish draft and reduce oil after-drip related problems.

FEATURES

Limited Recycle

This feature limits the number of recycle trials (for each call for heat) to a maximum of three trials. If the flame is lost three times and does not successfully satisfy a call for heat, the R7184 locks out.

Pump Priming Cycle

To facilitate purging air from the oil lines and filters, the R7184 can be placed in a purge routine by pressing and releasing the reset button during the safety check, delayed valve-on, ignition or carry-over periods. The

lockout timing will be extended to 4 minutes and the ignition set in the intermittent mode for this cycle only. The R7184 automatically reverts to its labeled interrupted and safety switch timing states. The pump priming cycle can only be entered if there have been no lockout occurrences since the last successful heat call. To reset the device so that the pump priming cycle can be entered, press and hold the reset button for 30 seconds until the LED flashes twice.

Disable Function

Pressing and holding the reset button will disable all functions until the button is released. The R7184 will restart at the beginning of the normal heat cycle on safety check.

Limited Reset (Restricted Mode)

In order to limit the accumulation of unburned oil in the combustion area, the control can only be reset three times. The reset count returns to zero each time a call for heat is successfully completed.

To reset from restricted mode: Press and hold the reset button for 30 seconds. When the LED flashes twice, the device has reset.

SPECIFICATIONS

Models:

Table 1 lists the major features and the applicable wiring diagram numbers for the R7184.

Timing:

Safe Start Check: 5 seconds (approximately).

Valve-on Delay: 15 seconds.

Burner motor-off Delay: 0, 2, 4, or 6 minutes, field-selectable using DIP switch positions 1 and 2.

NOTE: For universal R7184U model, valve-on delay and burner motor-off delay timings can be enabled (values as listed) or disabled (values are zero) in the field using DIP switch position 3.

Lockout: 15, 30 or 45 seconds (factory-programmed).

Recycle: 60 seconds (fixed).

Ignition Carryover: 10 seconds (fixed).



Electrical Ratings:

Inputs:
 Voltage: 102 to 132 Vac, 120 Vac nominal.
 Current: 100 mA plus burner motor, valve and ignitor loads.
 Frequency: 60 Hz.

Outputs:
 Relay Contacts:
 Burner: 120 Vac, 10 full load amperes (FLA),
 60 locked rotor amperes (LRA).
 Valve: 120 Vac, 1A.
 Ignitor: 120 Vac, 360 VA.
 Alarm: 30 Vac, 2A.
 Thermostat Current Available: 100 mA.

NOTE: Reduce burner FLA rating by Ignitor load. For example, if the ignitor draws 3A (120 Vac, 360 VA), reduce the burner motor FLA to 7A.

Environmental Ratings:

Operating Ambient Temperature: -40°F (-40°C) to +147°F (+64°C).
 Shipping Temperature: -20°F (-29°C) to +150°F (+66°C).
 Humidity: 90% relative humidity at 95°F (93°C) noncondensing.

Approvals:

Underwriters Laboratories Inc.: Recognized.
 Canadian Underwriters Laboratories Inc.

Table 1. R7184 Models.

Model	Valve-on delay (sec)	Burner motor-off delay (min)	Alarm Contacts	Typical Wiring Diagram Fig. Reference No.	Thermostat Terminals T-T
R7184A	None	None	None	3,4,5	Yes
R7184B	15	None	None	3,6,7	Yes ^c
R7184P ^a	15	0/2/4/6 ^b	Optional	3,6,7	Yes
R7184U	Selectable 0 or 15	Selectable 0 or 0,2,4,6 ^b	Yes	3,6,7	Yes

^aSome select models may have a delay enable/disable switch.

^bStandard timings. Other timing may be available on select models.

^cSelect models are provided with a T-T jumper which can be disabled by cutting with a pair of side-cutting pliers.

INSTALLATION

When Installing this Product...

1. Read these instructions carefully. Failure to follow instructions can damage product or cause a hazardous condition.
2. Check ratings given in these instructions and on product to make sure product is suitable for your application.
3. Make sure installer is a trained, experienced service technician.
4. Use these instructions to check out product operation after installation.

⚠ WARNING

Electrical Shock Hazard.
Can cause serious injury or death.
 Disconnect power supply before beginning installation to prevent electrical shock or equipment damage.

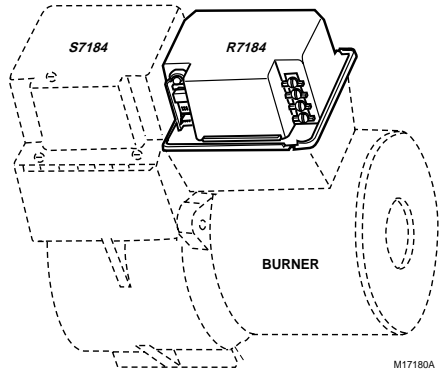

Fig. 1. Mounting R7184 on junction box.

Location

1. Mount on a 4 in. by 4 in. junction box, directly on the main burner or inside the appliance cabinet. In replacement applications, mount in the same location as the old control. See Fig. 1. Make sure the operating temperatures are within the ambient temperature range (see Specifications section).
2. Before mounting the control, make line voltage connections as shown in Fig. 2 through 7. Splice lines with solderless connectors. Do not exceed load ratings shown on the device label.
3. If necessary, use the control as a template to mark and drill new mounting holes.
4. Mount using No. 6 screws (obtained locally).

WIRING

1. Make sure wiring complies with all local codes and ordinances.
2. After mounting, make low voltage connections to the screw terminals (see Fig. 2 through 7).
3. Strip leads 3/8 in. (10 mm) and insert under terminal screw. See Fig. 1.
4. Connect thermostat leads to T-T.

Switch Settings

Figure 8 and Table 2 provide the switch settings for the R7184U.

CHECKOUT

Start System

⚠ WARNING

Fire Hazard.
Can cause serious injury or death.
 Make sure combustion chamber is free of oil and/or oil vapor before starting system.

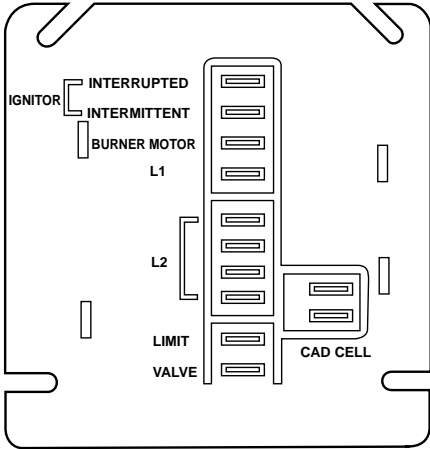

Fig. 2. Wiring terminals.

1. Open hand valve in oil supply line.
2. Make sure system is powered. Check circuit breaker or fuse and close system switch, if provided.
3. Set thermostat to call for heat.
4. Make sure burner lights and operates until call for heat ends.

Check Safety Features

Safe Start

1. Place a jumper across cad cell terminals.
2. Follow procedure to turn on burner. Burner must not start, indicator light turns on and control remains in Idle Mode.

Simulate flame failure:

1. Follow procedure to turn on burner.
2. Close hand valve in oil supply line.
3. Device enters recycle mode.
4. Device tries to restart system after approximately 60 seconds.
5. Safety switch locks out approximately in safety switch timing indicated on label. Indicator light flashes at 1 Hz rate. Ignition and motor stop and oil valve closes.

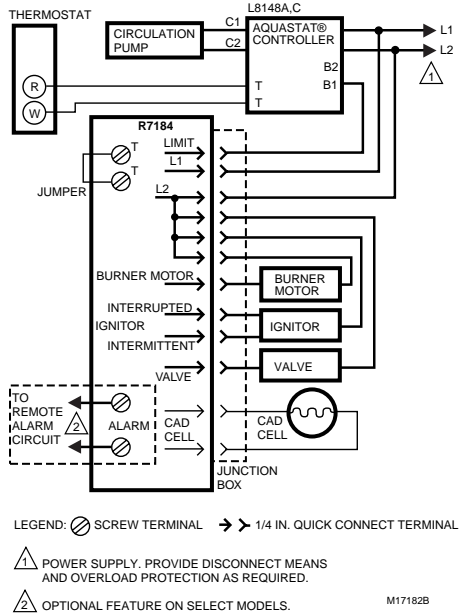

Fig. 3. Wiring for typical oil-fired boiler.

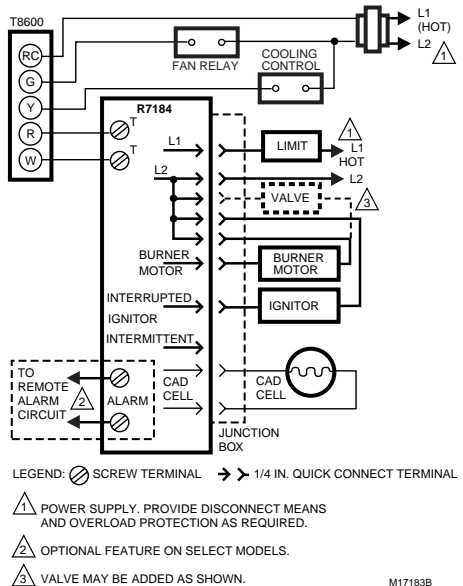

Fig. 4. Typical wiring diagram for 24 Vac thermostat and R7184 for an oil-fired forced air system.

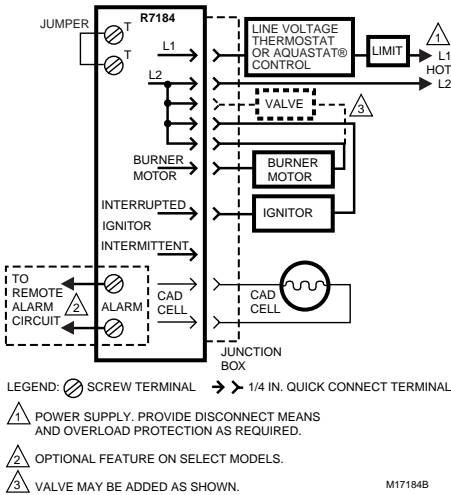

Fig. 5. Typical wiring diagram for line voltage Aquastat® thermostat and R7184 for an oil burner system.

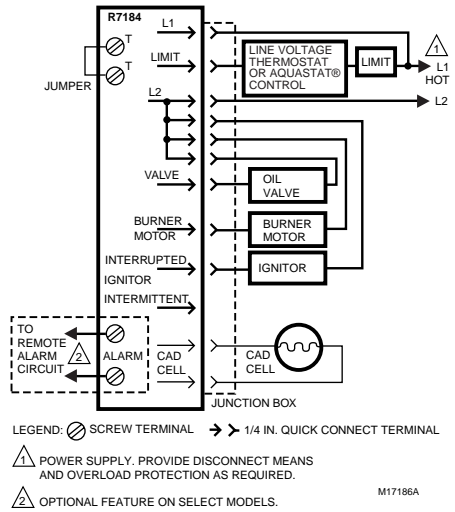

Fig. 7. Typical wiring diagram for line voltage Aquastat® thermostat and R7184B,P,U for valve-on delay/burner motor-off delay oil burner system.

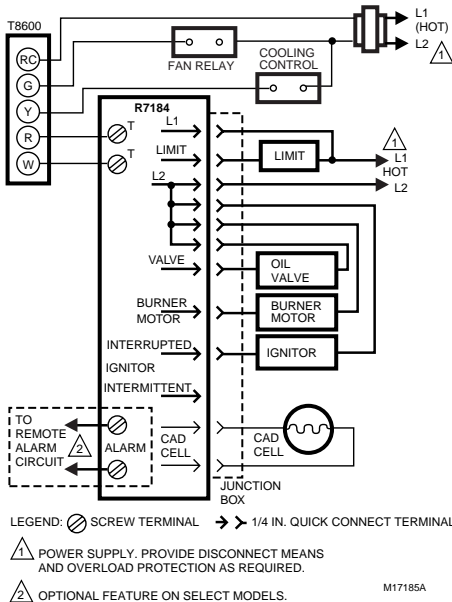

Fig. 6. Typical wiring diagram for 24 Vac thermostat and R7184 for valve-on delay/burner motor off oil burner system.

Simulate ignition failure:

1. Follow starting procedure to turn on burner, but do not open oil supply hand valve.
2. Observe that safety switch locks out approximately within safety switch timing as indicated on the label. Indicator light flashes at 1 Hz rate. Ignition and motor stop and oil valve closes.

OPERATION

The R7184 is a microprocessor-based control. The indicator light provides diagnostic information for lockout, recycling and patented cad cell status. There is a manual reset button to exit the lockout mode and enter the idle mode. Operation is shown in Table 4.

TROUBLESHOOTING AND MAINTENANCE

IMPORTANT:

Due to the potential hazard of line voltage, only a trained, experienced service technician should perform the troubleshooting procedure.

This control contains no field-serviceable parts. Do not attempt to take it apart. Replace entire control if operation is not as described.

To completely troubleshoot an oil burner installation, check the burner and oil primary control for proper operation and condition.

The indicator light on the oil primary control provides lockout, recycle and cad cell indications as follows:

- Flashing at 1 Hz (1/2 second on, 1/2 second off): system is locked out or in restricted mode.
- Flashing at 1/4 Hz (2 seconds on, 2 seconds off): control is in recycle mode.
- On: cad cell is sensing flame.
- Off: cad cell is not sensing flame.

VALVE ON DELAY TIME: 15 SEC. (FIXED)

BURNER MOTOR OFF DELAY TIME:



DELAY TIMES:

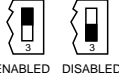

(SHADED AREA IS SWITCH HANDLE POSITION)

M17535

Fig. 8. Switch settings for burner-off delay times.

Table 2. Switch Settings and Delays.

Delay Timings			DIP Switch Settings			
Valve-On Delay (seconds)	Burner Motor-Off Delay (minutes)		S-1	S-2	S-3 Enable/Disable	
	R7184U	R7184P			R7184U	R7184P
0	0	—	X	X	Off	+
15	0	0.5	Off	Off	On	+
15	2	2	Off	On	On	+
15	4	4	On	Off	On	+
15	6	8	On	On	On	+

X = Don't Care.

+ = S-3 not provided on R7184P models.

Cad Cell Resistance Check

For proper operation it is important that the cad cell resistance is below 1600 ohms. During a normal call for heat, once the control has entered the Run mode, press and release the reset button. Indicator light will flash 1 to 4 flashes. See Table 3 for equivalent cad cell resistance.

Table 3. Cad cell resistance when sensing flame.

Flashes	Cad Cell Resistance in ohms
1	Less than 400
2	More than 400 and less than 800
3	More than 800 and less than 1600
4	More than 1600 and less than 5000

Preliminary Steps

- Check wiring connections and power supply.
- Make sure power is on to the controls.
- Make sure limit control is closed.
- Check contacts between ignitor and the electrodes.
- Check the oil pump pressure.

- Check the piping to the oil tank.
- Check the oil nozzle, oil supply and oil filter.

Check Oil Primary Control

If the trouble is not in the burner or ignition hardware, check the oil primary control by using the following equipment:

- Screwdriver.
- Voltmeter (0 to 150 Vac).
- Insulated jumper wire with both ends stripped.

WARNING

Electrical Shock Hazard.

Can cause serious injury or death.

Troubleshoot with the system powered. Be careful to observe all precautions to prevent electrical shock or equipment damage.

Refer to Table 4 for further troubleshooting information.

Table 4. R7184 Operation.

External Action	R7184 Action
Power applied to control.	Internal safety check conducted. If no light or flame is detected and all internal conditions are correct, control enters Idle mode.
Thermostat or Aquastat® Control calls for heat.	<ol style="list-style-type: none"> 1. Shorts across T-T terminals (on as call for heat) in warm air system and/or provides power to limit terminals in hydronic system. 2. Safety Period (4 seconds) internal and external check for flame or light. If flame or light is detected, control remains in Idle mode. 3. When flame or light is not present: <ol style="list-style-type: none"> a. R7184A,U (if valve-on delay is disabled) will apply power to the burner motor and ignitor. b. R7184B,P,U (if valve-on delay is enabled) will apply power to the burner motor and ignitor, enter/complete valve-on delay period and then apply power to the valve. 4. Control enters Trial for Ignition period. <ol style="list-style-type: none"> a. Monitors burner for flame. b. When flame is not detected: <ol style="list-style-type: none"> (1) Enters lockout mode (after lockout time of 15, 30 or 45 seconds). (2) Shuts off valve, ignitor and burner motor. (3) Flashes indicator light at 1 Hz (1/2 second on, 1/2 second off). (4) Depress reset button to return to power up sequence. c. When flame is detected, Carry-Over period begins: 5. Control enters Ignition Carry-Over period (continues to spark for 10 to 30 seconds). <ol style="list-style-type: none"> a. Turns on indicator light. b. If flame is lost and lockout time has not expired, R7184 returns to Trial for Ignition period. c. If flame is lost and lockout time has expired, R7184 enters Recycle Mode. 6. Carry-Over time expires; ignitor turns off. 7. Enters Run Mode: <ol style="list-style-type: none"> a. Flame is monitored until call for heat ends or flame is lost. If flame is lost: <ol style="list-style-type: none"> (1) Control enters Recycle Mode. (2) Recycle time starts (60 seconds). (3) Burner and valve are turned off. (4) Indicator light flashes at 1/4 Hz (2 seconds on, 2 seconds off). (5) Returns to Idle mode at end of Recycle mode.
Call for heat is satisfied.	<ol style="list-style-type: none"> 1. R7184A,U (if burner motor-off delay is disabled): <ol style="list-style-type: none"> a. Burner motor and oil valve shut off. b. Indicator light turns off. 2. R7184B,P,U (if burner motor-off delay is enabled): <ol style="list-style-type: none"> a. Oil valve shuts off. b. Burner motor runs for selected burner motor-off delay. c. Burner motor turns off. d. Device returns to Idle mode.
Reset button pushed two times without device completing a call for heat.	<ol style="list-style-type: none"> 1. R7184 enters Restricted mode. 2. Indicator light flashes at 1Hz (1/2 second on, 1/2 second off). 3. Reset device by pressing and holding reset button for a minimum of 30 seconds.

Table 5. Troubleshooting Information .

Procedure	Status	Corrective Actions
Condition: Burner does not start with a call for heat.		
1. Check that limit switches are closed and contacts are clean.	—	—
2. Check for line voltage power at the oil primary control. Voltage should be 120 Vac.	—	—
3. Check indicator light with burner off, no call for heat (no flame).	Indicator light is on.	Cad cell or controller is defective, sees external light or connections are shorted. Go to step 4.
	Indicator light is off.	Go to step 5.

Table 5. Troubleshooting Information (Continued).

Procedure	Status	Corrective Actions
4. Shield cad cell from external light.	Indicator light turns off.	Eliminate external light source or permanently shield cad cell.
	Indicator light stays on.	<ul style="list-style-type: none"> • Replace cad cell with new cad cell and recheck. • If indicator light does not turn off, remove cad cell leadwires from R7184 and recheck. • If indicator light turns off, replace cad cell bracket assembly. Refer to TRADELINE® Catalog for bracket part numbers. • If indicator light does not turn off, replace controller.
5. On warm air systems, jumper thermostat (T to T) terminals on R7184. (On hydronic systems jumper Limit terminal and L1 of R7184.) IMPORTANT: <i>First remove one thermostat lead.</i>	Burner starts.	Trouble in thermostat or limit circuit. Check thermostat or limit wiring connections.
	Burner does not start.	<ul style="list-style-type: none"> • Disconnect line voltage power and open line switch. • Check all wiring connections. • Tighten any loose connections and recheck. • If burner does not start, replace R7184.
Condition: Burner starts, then locks out on safety with indicator light flashing at 1 Hz rate (1/2 second on, 1/2 second off).		
1. Check that limit switches are closed and contacts are clean.	—	—
2. Check for line voltage power at the oil primary control. Voltage should be 120 Vac.	—	—
3. Check indicator light with burner off, no call for heat (no flame).	Indicator light is on.	Cad cell or controller is defective, sees external light or connections are shorted. Go to step 4.
	Indicator light is off.	Go to step 5.
4. Shield cad cell from external light.	Indicator light turns off.	Eliminate external light source or permanently shield cad cell.
	Indicator light stays on.	<ul style="list-style-type: none"> • Replace cad cell with new cad cell and recheck. • If indicator light does not turn off, remove cad cell leadwires from R7184 and recheck. • If indicator light turns off, replace cad cell bracket assembly. Refer to TRADELINE® catalog for bracket part numbers. • If indicator light does not turn off, replace controller.
5. On warm air systems, jumper thermostat (T to T) terminals on R7184. (On hydronic systems, jumper Limit terminal and L1 of R7184.) IMPORTANT: <i>First remove one thermostat lead.</i>	Burner starts.	Trouble is in thermostat or limit circuit. Check thermostat or limit wiring connections.
	Burner does not start.	<ul style="list-style-type: none"> • Disconnect line voltage power and open line switch. • Check all wiring connections. • Tighten any loose connections and recheck. • If burner does not start, replace R7184.
Condition: Burner starts then locks out on safety with indicator light flashing at 1 Hz rate (1/2 second on, 1/2 second off)		
6. Reset oil primary control by pushing in and releasing red reset button.	Indicator light stops flashing.	Go to step 7.
	Indicator light continues to flash at 1 Hz rate ^a .	Verify that control is not in restricted mode (see footnote a). If not in restricted mode, replace R7184.

Table 5. Troubleshooting Information (Continued).

Procedure	Status	Corrective Actions
7. Listen for spark after burner turns on (after a 2 second delay).	Ignition is off.	Spark ignitor could be defective. Check for line voltage at ignitor terminals. If line voltage is present, replace R7184.
	Ignition is on.	Go to step 8.
	Ignition is on, but no oil is being sprayed into the combustion chamber.	Wait for Valve On Delay to complete (R7184B,P, and U). Check oil valve, oil valve wiring, pump and oil supply.
8. Check indicator light after flame is established, but before oil primary control locks out.	Indicator light is on until the control locks out and starts flashing during lockout.	Replace R7184.
	Indicator light stays off.	Go to step 9.
9. Check cad cell sighting for view of flame. <ul style="list-style-type: none"> Disconnect line voltage power and open line switch. Unplug cad cell and clean cad cell face with soft cloth. Check sighting for clear view of flame. Place cad cell back in socket. Reconnect line voltage power and close line switch. Start burner. 	Burner locks out.	Go to step 10.
	Burner keeps running.	System is okay.
10. Check cad cell. <ul style="list-style-type: none"> Disconnect line voltage power and open line switch. Remove existing cad cell and replace with new cad cell. Disconnect all wires from thermostat terminals to be sure there is no call for heat. Reconnect line voltage power and close line switch. Expose new cad cell to bright light, such as a flashlight. 	Indicator light is on.	Place control back on burner. Go to step 6.
	Indicator light is off.	Go to step 11.
11. Check cad cell bracket assembly. <ul style="list-style-type: none"> Disconnect line voltage power and open line switch. Remove cad cell wires from quick-connect connectors on the R7184 and leave control leadwires open. Apply power to device. Place jumper across cad cell terminals after burner motor turns on. 	Indicator light is on.	Replace cad cell bracket assembly. Refer to TRADELINE® Catalog for bracket part numbers.
	Indicator light is off.	Replace R7184.

Honeywell

Home and Building Control

Honeywell Inc.
Honeywell Plaza
P.O. Box 524
Minneapolis, MN 55408-0524

Home and Building Control

Honeywell Limited-Honeywell Limitée
155 Gordon Baker Road
North York, Ontario
M2H 3N7



Free Manuals Download Website

<http://myh66.com>

<http://usermanuals.us>

<http://www.somanuals.com>

<http://www.4manuals.cc>

<http://www.manual-lib.com>

<http://www.404manual.com>

<http://www.luxmanual.com>

<http://aubethermostatmanual.com>

Golf course search by state

<http://golfingnear.com>

Email search by domain

<http://emailbydomain.com>

Auto manuals search

<http://auto.somanuals.com>

TV manuals search

<http://tv.somanuals.com>