



CONTROL YOUR ENVIRONMENT WITH HONEYWELL
DAMPERS, VALVES AND ACTUATORS

Application And Selection Guide

How to use this guide

All pages in this literature are constructed in one of two ways:

For unassembled product:

As a reference, pictures will represent the valves and actuators separately; and part numbers are highlighted in blue. To order a complete product one OS# must be chosen from each blue box.

For factory assembled product:

The complete assembled OS# will be displayed in the body of the chart (except for cartridge cage valves, both an actuator and valve must be chosen). Pictures will also reference the factory assembled configuration.

Additional product information

To find more detailed information on the individual products included in this document, go to: <http://customer.honeywell.com> and use the search text box to quickly locate product specific content.

SUPPORT

Contact Information

Commercial Components

Technical Hotline

Phone

888-516-9347

Fax

Customer Care

Order Entry

888-793-8193

800-356-0149

Product Drop-Ship Team

763-954-4140

800-356-0149

Butterfly & Flanged Control Ball Valve Ordering

Take-Off Service

888-664-4092

877-880-3386

Let Honeywell Take-Off Service provide a complete job schedule for your projects for dampers, actuators, valves and VFDs.

Online Resources

Honeywell Customer Web Site

A web site with a large amount of information, literature, pricing, and product selection tools that is available to you at any time.

<http://customer.honeywell.com>

Honeywell Consulting Engineer Web Site

A website developed for consulting engineers. Get product guide specs, wiring diagrams and more.

<http://specifyhoneywell.com>

Honeywell eLearning

A convenient and smart way of learning about our products with 10 to 20 minute training modules. Register at the Honeywell customer website above for access.

<http://customer.honeywell.com/learning>

Section 1: DCA & Damper Selection

Dampers8
 DCA12
 Fire and Smoke.....14

Section 2: Valve Selection

Control Valve Applications17
 Control Valve Selection Criteria18
 2-Way18
 3-Way20
 Fan Coil and Zone Valves22
 Cartridge Cage Valves.....24
 Cartridge Globe Valves.....26
 Control Ball Valves ½ - 3”
 2-Way NPT NEMA 228
 2-Way NPT NEMA 3R.....30
 Control Ball Valves ½ - 2 ½”
 3-Way NPT NEMA 232
 3-Way NPT NEMA 3R.....33
 Flanged Control Ball Valves 4”- 6”
 2-Way Flanged NEMA 2+3R.....34
 3-Way Flanged NEMA 2+3R.....35
 NPT Globe Valves ½-3”
 With Dedicated Valve Actuators36
 With Direct Coupled Actuators.....38
 Flanged Globe Valves 2 ½ -3”
 With Direct Coupled Actuators.....42
 Threaded and Flanged Globe Valves 2”-3”
 With Tandem Linked Direct Coupled Actuators.....46
 Flanged Globe Valves 2 ½ - 3”
 With Dedicated Valve Actuators48
 Flanged Globe Valves 4”-6”
 With Tandem Linked Direct Coupled Actuators.....52
 With Dedicated Valve Actuators54
 Flanged Cage Valves 2 ½ - 6”55
 NPT Globe Valves ½ -3”
 With Pneumatic Actuators.....56
 Flanged Globe Valves 2 ½ - 3”
 With Pneumatic Actuators.....60
 Flanged Globe Valves 4”- 6”
 With Pneumatic Actuators.....64

Resilient Seat Butterfly Valves

2-Way Electrically-Actuated Control66
 3-Way Electrically-Actuated Control68
 2-Way Pneumatically-Actuated Control.....72
 3-Way Pneumatically-Actuated Control.....74

Section 3: Submittal Sheets

Rectangular Volume Control Dampers

D1 Series78
 D2 and D3 Series.....79

Round Volume Control Dampers

D69080
 DM7600.....81

Spring Return Direct Coupled Actuator

S03 Series (MS4103; MS4603; MS7403; MS7503; MS8103) ...82
 S05 Series (MS4105; MS4605; MS7105; MS7405; MS7505;
 MS8105)83
 S05 Series (MS4105; MS7505; MS8105)84
 S10 Series (MS4110; MS7510; MS8110)85
 S20 Series (MS4120; MS7520; MS8120)86

ML4125; ML812587

Non-Spring Return Direct Coupled Actuator

ML6161; ML716188
 ML6174; ML717489
 N05 Series (MN6105; MN7505).....90
 N10 Series (MN6110; MN7510).....91
 N20 Series (MN6120; MN7220).....92
 N34 Series (MN6134; MN7234).....93

Fire And Smoke Actuators

ML4115; ML811594
 MS4209F; MS4309F; MS4709F; MS4809F; MS8209F;
 MS8309F95
 MS4120F; MS4620F; MS8120F96

Pneumatic Damper Actuator

MP909D.....97
 MP909E, H98
 MP91399
 MP918A, B100
 MP920101

Pneumatic Valve Actuator

MP953C, D102
 MP953E, F103

Section 3: Submittal Sheets (CONT.)

MP958 104

Modutrol IV Motor

 M4185; M8185 105

 M6184; M6194 106

 M6285 for slaving applications 107

 M6284; M6294 for slaving applications 108

 M6274; M6284; M6285; M6294 Motors with
 Linear 10K Feedback 109

 M7164 110

M7274; M7284; M7285; M7286; M7294 111

 M9164; M9174; M9182; M9184; M9194 112

 M9175; M9185; M9186 113

 Q7130; Q7230; Q7330 114

Unitary Valve Actuator

 VU443; VU444; VU843; VU844 115

 VC Series Two-position 116

 VC Series Proportional 117

 VC Series Fail Safe Proportional 118

 M6410; M7410 119

 M6435; M7435 120

Direct Coupled Valve Actuator

 ML6420; ML7420 121

 ML6421; ML7421 122

 ML6425; ML7425 123

 ML6984 124

 ML7984 125

Unitary Valve

 VU52; VU53 126

 VU54 127

 VCZA; VCZB 128

 VCZM; VCZN 129

 V5852; V5862 130

 V5853; V5863 131

Control Ball Valve

 VBN2 132

 VBN3 133

 VBF2 134

 VBF3 135

NPT Globe Valve

 V5011F, G 136

 V5011N 137

 V5013N 138

Flanged Cage Valve

 V5051A 139

Flanged Globe Valve

 V5011A, B 140

 V5013B, C 141

 VGF2 142

 VGF2 Pressure Balanced 143

 VGF3 144

Resilient Seat Butterfly Valves

 VFF1 145

 VFF2 146

 VFF3 147

 VFF6 148

Damper Linkage

 Q605 149

Valve Linkage

 Q5001 150

 Q5020 151

 Q5022 152

Section 4: Wiring Diagrams

Actuator Wiring Diagrams 154

Section 5: Guide Specifications

Guide Specifications 170

Section 6: Accessories

Ball Joints, Push Rod Accessories 186

Control, Positioning, Feedback Accessories 186

Mounting Accessories 187

Rotational Limiters, Position Indicators 188

Crankarms 189

Shaft Adaptor Accessories 189

Enclosure Accessories 190

Q7002 Interface Modules 190

Miscellaneous Accessories 190

Accessories for Obsolete Actuators 191

Valve Actuator Accessories 192

VU Series Fan Coil Actuator Accessories 192

Pneumatic Damper Actuator Parts and Accessories 193

Pneumatic Valve Actuator Parts and Accessories	196
Foot Mounted Motor Accessories	198
Damper and Valve Linkage Accessories.....	200

Section 8: Competitive Cross Reference

Direct Coupled Actuator.....	202
Control Ball Valve	
2-Way Valve	220
2-Way Valve + Non-Spring Return Floating Actuator.....	221
2-Way Valve + Non-Spring Return Modulating Actuator.....	222
2-Way Valve + Spring Return, 2-Position Actuator	223
2-Way Valve + Spring Return Floating Actuator.....	224
2-Way Valve + Spring Return Modulating Actuator	225
Threaded Globe Valves	226
Flanged Globe Valves.....	227
Pneumatics	228
Modutrol IV Motor	231

Section 8:

APPENDIX A:

Valve Selection & Sizing	244
--------------------------------	-----

APPENDIX B:

NEMA Standard Classification Code for Enclosures	263
--	-----

APPENDIX C:

Best Practices for Low Power Control Signal Wiring	264
--	-----

Notes	265
-------------	-----

Warranty.....	267
---------------	-----

Section 1: DCA & Damper Selection

Dampers	8
DCA	12
Fire and Smoke.....	14

Damper And Actuator Sizing

Use the following guidelines to determine the actuator quantity and torque requirements for your damper configuration.

Determine Damper Actuator Locations

Use the following configuration to determine the amount of actuator locations your damper will require.

Single Section $\leq 48 \times 74$ D2, D3
 $\leq 60 \times 74$ D1

Dampers will never ship more than 2 sections wide and one section high.

Configuration

A single section damper will have one actuator location.

A damper that is $\geq 48 \times 74 \leq 96 \times 74$ will have one actuator location. This is a two section damper jackshafted together.

A damper that is $\geq 96 \times 74 \leq 144 \times 74$ will have two actuator locations. This is a two section damper jackshafted together and a single section damper.

Exception: 3 section wide ≤ 42 SFT damper will have one actuator location.

If damper exceeds 74" height a second row is necessary. Apply same logic above to each row of dampers.

For dampers larger than 144 x 144, please contact the Take-Off Service (takeoff.service@honeywell.com) for a quote and actuator location.

Mounting

Internal Mount: Blade drive lever bracket provided only. Customer is responsible for providing mounting hardware.

External Mount: Actuator shaft will be provided as extension pin kit to be mounted on side or with jackshaft pre-mounted on damper.

Determining Damper Actuator Torque Requirements

Use the following procedure to determine the required torque for your damper.

NOTE: Damper area is measured using the H and W dimensions.

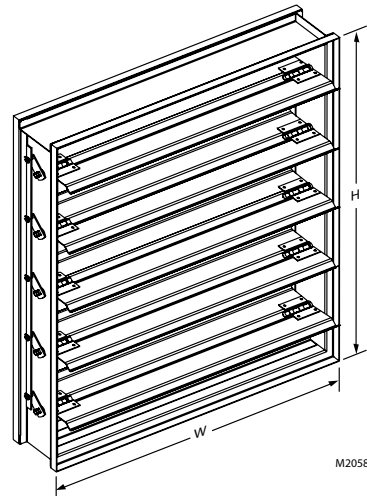

Measuring Damper Area

1. Calculate the damper area in square feet by multiplying the H dimension by the W dimension.
2. Multiply the damper area by the lb-in. per square foot value from Table 2 on page 9.

NOTE: The minimum lb-in. per square foot value that can accommodate tight closeoff and no leakage applications is 5, regardless of the value shown in the table.

3. Select the highest actuator torque value than the calculated value.

EXAMPLE:

Low leakage, parallel blade damper:

H dimension = 48 in.

W dimension = 96 in.

Static pressure (in. w.c.) = 2 in. w.c.

Face Velocity = 1000 fpm

$48 \text{ in.} \times 96 \text{ in.} \div 144 = 32 \text{ sq. ft.}$

$32 \text{ sq. ft.} \times 7 \text{ lb-in./sq. ft.} = 224 \text{ lb-in.}$

where 7 lb-in./sq. ft = value from Table 2.

In this case you would need an actuator with a minimum nominal torque of 224 lb-in.

Damper And Actuator Sizing

Table 2. Approximate industry standard damper lb-in. per sq ft value.

Leakage	Damper Blades	Face Velocity (fpm)/ Static Pressure (in. wc)				
		500/ 1	1000/ 2	1500/ 3	2000/ 4	2500/ 5
Low	Parallel	4	7	10.5	12	14
Low	Opposed	3	5	7.5	8.5	10
Standard	Parallel	3	4.5	6.5	7	8
Standard	Opposed	2	3	4.5	5	6

Damper Sizing

Dampers can be sized using two different methods; actual sizing and nominal sizing. When actual sizing is used the damper dimensions will be the same as the sizes ordered. For example, when a 24 inch x 24 inch D640 damper is ordered, it will be made such that the height is 24 inches and the width is 24 inches. When nominal sizing is used, the damper dimensions will be $\frac{1}{4}$ inch smaller than the sizes ordered. For example, when a 24 inch x 24 inch D640 is ordered, it will be made such that the height is 23.75 inches and the width is 23.75 inches. No special allowances are required for dampers that are constructed of multiple sections. For example, a damper that is 24 inch x 60 inch will be constructed of two sections. When ordered using nominal sizing, the damper size will be 23.75 inches high by 59.75 inches wide.

Actual sizing is commonly used when the exact size of the opening is known or if the damper is not meant to be installed inside an opening or duct. Nominal sizing, with its $\frac{1}{4}$ inch undersizing is commonly used when the damper will be installed inside an opening or duct and space is needed for positioning or seal material.

Honeywell's sizing default is nominal sizing. If actual sizing is required, please make sure this is specified on the order. For more information on ordering Honeywell dampers, please contact your local Honeywell distributor or sales representative.

Damper And Actuator Sizing

HVAC performance depends largely upon airflow, and Honeywell Volume Control Dampers are built for both improved airflow and heavy-duty use. Honeywell has long been the leading source for airflow control, with Volume Control Dampers that meet AMCA-certified Air Performance Standards, the highest established standards for commercial control dampers. Designed to minimize leakage, Honeywell dampers will give you efficient, trouble-free operation for years to come.

Standard Rectangular Dampers



Durable construction details are the cornerstone of Honeywell D1, D2 and D3 Volume Control Dampers. They feature heavy-duty hat channel frames for dependable operation inside ductwork. And all models have low-profile top and bottom frames, creating more free area while reducing pressure loss and reducing actuator torque.

The Right Choice

There's a Honeywell Volume Control Damper that's just right for your application. The D1 airfoil extremely low leakage damper presents a lower resistance to airflow typically used in high pressure systems. The D2 ultra-low leakage damper keeps leakage to a minimum with blade and jamb seals, and is designed for medium- to high-pressure and velocity systems. The D3 low leakage damper is ruggedly built for applications in medium pressure and velocity systems.

Blade Design

Airfoil Blades - D1 Dampers

Honeywell Airfoil Volume Control Dampers feature blades constructed of double skin galvanized steel. This design presents a lower resistance to airflow and has strength that is typically used in high pressure systems.

3-V Blades - D2 and D3 Dampers

Honeywell Volume Control Dampers feature a 3-V design that's proven to meet higher-level system requirements while minimizing flow-through system loss. Blades are fabricated from a single thickness of 16-gauge galvanized steel with three horizontal structural V-grooves running the length of the blade.

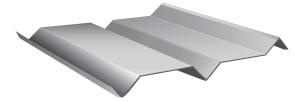

Applications And Operation

Honeywell Volume Control Dampers are designed to control airflow volume in medium- to high-pressure and velocity HVAC systems. Typical applications include volume control of airflow in zoning, air handler unit or economizer applications. Dampers are designed to operate with a wide range of Honeywell electric and pneumatic actuators. Operating range is from 2000 to 4000 fpm, and 2.5 to 6 inch wg. Spring return and non-spring return actuators are available with a wide range of output torque ratings to deliver the precise power needed for your damper application.

Certified Performance

Honeywell certifies that models D2 and D3 are licensed to bear the AMCA Seal. The ratings shown are based on tests and procedures performed in accordance with AMCA Publication 511 and comply with the requirements of the AMCA Certified Ratings Programs. The AMCA Certified Ratings Seal applies to air performance ratings only.

	Material			Frame Gauge			Blade Seals		Bearings			Axles		Linkage Material		Flange				
	Galvanized	Stainless	Aluminum	16	14	12	Vinyl	Silicone	Synthetic	Bronze	Stainless	Steel	Stainless	Steel	Stainless	None	Single	Double	Reverse	
S — Standard O — Optional																				
D1 Airfoil Extremely Low Leakage Volume Control Damper	S	O	n/a	S	O	O	n/a	S	S	O	O	S	O	S	O	S	O	O	O	
D2 Ultra-Low Leakage Volume Control Damper	S	O	O	S	O	O	S	O	S	O	O	S	O	S	O	S	O	O	O	
D3 Low Leakage Volume Control Damper	S	O	O	S	O	O	n/a	n/a	S	O	O	S	O	S	O	S	O	O	O	

For a copy of the specification sheet the D1 (63-2671) or D2 and D3 (63-2398), visit customer.honeywell.com.

Damper And Actuator Sizing

Standard Round Dampers

D690 and DM7600 Round Dampers. The 6" to 16" round dampers are used in zoning systems to control airflow in a round duct. These dampers come with neoprene and silicone seals for tight close off and low leakage. The DM7600 includes an actuator that is already attached to the round damper.

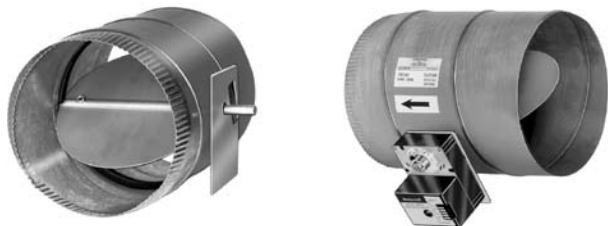

Custom Dampers

Need a custom damper? Contact the Take-Off Service. Below is a sample list of the products we frequently quote.

Custom Rectangular Dampers

Number	Description
VCD34	Galvanized Insulated Airfoil Damper
VCD40	Aluminum Narrow Frame Airfoil Damper
VCD42	Aluminum Airfoil Damper (Galvanized Frame)
VCD43	Aluminum Airfoil Damper
VCD45	Aluminum thermally broken insulated Damper

Custom Round Dampers

Number	Description
VCDR53	Galvanized Round Damper – to 24 inches
VCDRM53	Galvanized Round Multi-Blade Damper – to 36 inches

Specification Take-Off Service

- Submit your information in one of the following ways:
 - Email to takeoff.service@honeywell.com (preferred)
 - Fax toll-free to 1-877-880-3386 (local: 1-612-951-1238)
- Include your desired turn-around time.
- Take-Off Service staff will send you a confirmation that your email or fax was received.

We always attempt to have your request finished as soon as possible. Please note, however, that the quality of the submitted information largely determines the turn-around time. We will work closely with you to ensure that we have enough information to move forward as quickly as possible.

- A final product schedule document will be returned to you following take-off completion.

Included In the Final Take-Off Document

We send a comprehensive spreadsheet, which contains:

- A complete product schedule
- Base price
- Directions on how to order Honeywell products
- Links to product submittals
- Quote identification number

Questions

If you have questions about the Honeywell Take-Off Service, please call the dedicated Take-Off Service phone number or email us at takeoff.service@honeywell.com.

Don't see what you need?

Take-Off Service Contact Information:
Toll-free: 1-888-664-4092
Local: 1-612-951-1027

Direct Coupled Actuators

DIRECT COUPLED ACTUATORS QUICK SELECTION GUIDE



Spring Return,
Low Torque

Precise, reliable performance. Lasting value. Ease of installation. Everything you look for in direct-coupled actuators hinges on quality. And quality engineering is what makes Honeywell's complete line of actuators the top performers in the industry. Our global engineering team designs and tests our direct-coupled actuators to exceed rigorous global standards — and to meet Honeywell's own demanding life testing.

But we don't stop there. Thanks to our continuous improvement process, Honeywell actuators are now easier than ever to install. You'll also benefit from consistent wiring regardless of signal type, common accessories and a simplified selection process.

Honeywell's complete line of building control products, including valves and actuators, are already proven in more than three million buildings worldwide. So when you need spring or non-spring return actuators for your damper and valve applications, specify Honeywell. We make precision easy.

Improve Installation Time

- Self-centering shaft adapter provides mounting flexibility and greater clamping force.
- Common wiring among families for every signal saves installation time.

Decrease Material Cost

- Detachable access cover allows direct wiring without a junction box.

Reduce Inventory

- Signal mode switch adapts models to two-position, floating (tri-state), or modulating (proportional) applications.

Increase Control and Accuracy

- More than 200 reposition steps for modulating models provide precise control.



Spring Return,
High Torque



EASY-TO-SELECT MODEL NUMBERS

MS and MN Families

MS 75 10 A 2 2 XX

Fail Safe Mode

- **MS** Spring Return
- **MN** Non-Spring Return

Input Signal Type

- **41** Two-Position, 100-250 Vac
- **61** Floating, 24 Vac/dc
- **75** Modulating/Floating, 24 Vac/dc
- **81** Two-Position, 24 Vac/dc

Torque

- **03** Nm = 27 in-lb
- **05** Nm = 44 in-lb
- **10** Nm = 88 in-lb
- **20** Nm = 175 in-lb
- **34** Nm = 300 in-lb

System Controlled Numbers

Auxiliary Switches

- **0** No Internal Switches
- **2** Two Internal Switches

Feedback

- **1** No Feedback
- **2** Voltage Feedback

Application Type

- **A** Standard Model
- **H** Enhanced Model



Non-Spring Return,
Low Torque

ML Family

ML 61 61 B 2 XXX

Fail Safe Mode

- **ML** Non-Spring Return

Input Signal Type

- **61** Floating, 24 Vac
- **71** Modulating, 24 Vac

Torque

- **61** (4 Nm) = 35 in-lb
- **74** (8 Nm) = 70 in-lb

System Controlled Numbers

Declutch

- **1** Standard
- **2** Includes Declutch Function

Feedback & Conduit

- **A** Feedback w/Accessory
- **B** Standard
- **C** Feedback w/Accessory and Cover w/Conduit Connections
- **D** Cover w/Conduit Connections



Non-Spring Return,
High Torque

SPRING RETURN

Order Specification Number	Approximate Area of Damper (4.5 lb-in/sq. ft.)	Running Time		Power Supply			Control Input/Output					Auxiliary Knob		
		Drive (seconds)	Spring Return (seconds)	24 Vac/dc	120-230 Vac	VA Rating (Running)	On/Off	0/2-10 Vdc, Floating	3 kOhm NTC, 3-Position	Feedback (0/2-10 Vdc)	Adj. Zero and Span	SPDT Auxiliary Switches	Internal Minimum Position Potentiometer	
S03 Series (3 Nm, 27 lb-in)														
MS8103A1030	6	45	<25	•			•					0		
MS8103A1130	6	45	<25	•			•					1		
MS4103A1030	6	45	<25		•		•					0		
MS4103A1130	6	45	<25		•		•					1		
MS7503A2030	6	90	<25	•			•		•			0		
MS7503A2130	6	90	<25	•			•		•			1		
MS7403A2030	6	90	<25	•			•		•			0	•	
S05 Series (5 Nm, 44 lb-in)														
MS8105A1030	10	45	<25	•			•					0		
MS8105A1130	10	45	<25	•			•					1		
MS4105A1030	10	45	<25		•		•					0		
MS4105A1130	10	45	<25		•		•					1		
MS7505A2030	10	90	<25	•			•		•			0		
MS7505A2130	10	90	<25	•			•		•			1		
MS7405A2030	10	90	<25	•			•		•			0	•	
S10 Series (10 Nm, 88 lb-in)														
MS8110A1008	20	45	<25	•			•					0		
MS8110A1206	20	45	<25	•			•					2		
MS4110A1002	20	45	<25		•		•					0		
MS4110A1200	20	45	<25		•		•					2		
MS7510A2008	20	90	<25	•			•		•			0		
MS7510A2206	20	90	<25	•			•		•			2		
MS7510H2209	20	90	<25	•			•		•	•		2		
S20 Series (20 Nm, 175 lb-in)														
MS8120A1007	39	45	<25	•			•					0		
MS8120A1205	39	45	<25	•			•					2		
MS4120A1001	39	45	<25		•		•					0		
MS4120A1209	39	45	<25		•		•					2		
MS7520A2007	39	90	<25	•			•		•			0		
MS7520A2205	39	90	<25	•			•		•			2		
MS7520H2208	39	90	<25	•			•		•	•		2		

NON-SPRING RETURN

Order Specification Number	Approximate Area of Damper (4.5 lb-in/sq. ft.)	Running Time	Power Supply		Control Input/Output					SPDT Auxiliary Switches	
			24 Vac/dc	24 Vac	VA Rating (Running)	On/Off, Floating	0/2-10 Vdc	2-10 Vdc	Feedback (0/2-10 Vdc)		
N05 Series (5 Nm, 44 lb-in)											
MN6105A1011	10	90	•			•				0	
MN6105A1201	10	90	•			•				2	
MN7505A2001	10	90	•			•		•		0	
MN7505A2209	10	90	•			•		•		2	
N10 Series (10 Nm, 88 lb-in)											
MN6110A1003	20	90	•			•				0	
MN6110A1201	20	90	•			•				2	
MN7510A2001	20	90	•			•		•		0	
MN7510A2209	20	90	•			•		•		2	
N20 Series (20 Nm, 175 lb-in)											
MN6120A1002	39	90	•			•				0	
MN6120A1200	39	90	•			•				2	
MN7220A2007	39	90	•			•		•		0	
MN7220A2205	39	90	•			•		•		2	
N34 Series (34 Nm, 300 lb-in)											
MN6134A1003	67	90	•			•				0	
MN7234A2008	67	90	•			•		•		2	
ML6161/7161 (4 Nm, 35 lb-in)											
ML6161A2009	8	90	•	•	1.8	•				w/ accessory	0
ML6161A2017	8	420	•	•	1.8	•				w/ accessory	0
ML6161A2025	8	180	•	•	1.8	•				w/ accessory	0
ML6161B2024	8	90	•	•	1.8	•					0
MS6161B2032	8	420	•	•	1.8	•					0
ML6161B2073	8	180	•	•	1.8	•					0
ML6161C2007	8	90	•	•	1.8	•				w/ accessory	0
ML6161D2006	8	90	•	•	1.8	•					0
MS7161A2008	8	90	•	•	5.4	•		•			0
ML6174/7174 (8 Nm, 70 lb-in)											
ML6174A2002	16	90	•	•	2.4	•				w/ accessory	0
ML6174A2010	16	180	•	•	2.4	•				w/ accessory	0
ML6174B2019	16	90	•	•	2.4	•					0
ML6174B2035	16	420	•	•	2.4	•					0
ML6174D2009	16	90	•	•	2.4	•					0
ML6174E2008	16	90	•	•	2.4	•					0
ML7174A2001	16	90	•	•	5.4	•					0
ML7174E2007	16	90	•	•	5.4	•					0

¹ Consult Tradeline catalog for additional models.

² Assumes standard 1000 fpm system with parallel blade damper. Approximate square foot.

Fire & Smoke Actuators

Honeywell's complete line of two-position, fast-acting spring-return actuators meet all of your needs for fire and smoke control applications. All models are designed to meet the UL-555 and UL-555S high temperature requirements for fire dampers and combined fire and smoke dampers.

Safety First



As a life safety system component Honeywell is dedicated to meeting the UL-555 and UL-555S requirements. The elevated temperature test can be performed at the temperature ratings of 250°F or 350°F. Honeywell only offers models at 350°F to meet UL-555 and UL-555S for fire and combined fire and smoke applications to support the highest level of safety for building occupants.

Largest Torque Range in the Industry

Honeywell's fire and smoke actuators are available in 30, 80 and 175 lb-in with the 175 lb-in being the highest torque commercial fire and smoke actuator available on the market today.

Key Features and Benefits

- Integral spring return that ensures the proper level of torque
- Patented design that eliminated limit switches, reducing power consumption
- Reliable service in smoke control systems requiring Underwriter's Laboratories Inc. UL-555 and UL-555S
- Robust die-cast aluminum housing ensures
- Full life of two-position spring return fire and smoke actuators rated up to 350°F for all critical applications
- Fast acting with a maximum spring return timing of 15 seconds
- No audible noise during holding

	Torque	Voltage	Spring Direction	Description	Number of internal Auxiliary Switch	Model Number
	30 lb-in (3.4 Nm)	120 Vac	CCW	Fire and smoke, fast acting, two position spring return, UL-555 and UL-555S ratings up to 350°F	External*	ML4115A1009
			CW		External*	ML4115B1008
		230 Vac	CCW		External*	ML4115C1007
			CW		External*	ML4115D1006
		24 Vac	CCW		External*	ML8115A1005
			CW		External*	ML8115B1004
	80 lb-in (9 Nm)	120 Vac	CW	Fire and smoke, fast acting, two position spring return, UL-555 and UL555S ratings up to 350°F	External*	MS4209F1007
			CCW		External*	MS4309F1005
		230 Vac	CW		External*	MS4709F1014
			CCW		External*	MS4809F1012
24 Vac		CW	External*		MS8209F1003	
		CCW	External*		MS8309F1001	
	175 lb-in (20 Nm)	120 Vac	Reversible Design	Fire and smoke, fast acting, two position spring return, UL-555 and UL-555S ratings up to 350°F	0	MS4120F1006
					2 SPST	MS4120F1204
					0	MS4620F1005
					2 SPST	MS4620F1203
					0	MS8120F1002
					2 SPST	MS8120F1200

Note: Honeywell's spring return fire and smoke actuators are designed to pass UL-555 and UL-555S 350°F requirements. They are not designed for HVAC applications. UL-555 and UL-555S requires that all new construction fire and smoke damper jobs have the actuator assembled and tested at the damper manufacturer. A like for like retrofit replacement or technically equal UL-555 and UL-555S approved device is recommended.

Section 2: Valve Selection

Control Valve Applications	17	Threaded and Flanged Globe Valves 2"-3"	
Control Valve Selection Criteria	18	With Tandem Linked Direct Coupled Actuators.....	46
2-Way	18	Flanged Globe Valves 2 ½ - 3"	
3-Way	20	With Dedicated Valve Actuators	48
Fan Coil and Zone Valves.....	22	Flanged Globe Valves 4"-6"	
Cartridge Cage Valves.....	24	With Tandem Linked Direct Coupled Actuators.....	52
Cartridge Globe Valves.....	26	With Dedicated Valve Actuators	54
Control Ball Valves ½ - 3"		Flanged Cage Valves 2 ½ - 6"	55
2-Way NPT NEMA 2	28	NPT Globe Valves ½ -3"	
2-Way NPT NEMA 3R.....	30	With Pneumatic Actuators.....	56
Control Ball Valves ½ - 2 ½"		Flanged Globe Valves 2 ½ - 3"	
3-Way NPT NEMA 2	32	With Pneumatic Actuators.....	60
3-Way NPT NEMA 3R.....	33	Flanged Globe Valves 4"- 6"	
Flanged Control Ball Valves 4"- 6"		With Pneumatic Actuators.....	64
2-Way Flanged NEMA 2+3R.....	34	Resilient Seat Butterfly Valves	
3-Way Flanged NEMA 2+3R.....	35	2-Way Electrically-Actuated Control	66
NPT Globe Valves ½-3"		3-Way Electrically-Actuated Control	68
With Dedicated Valve Actuators	36	2-Way Pneumatically-Actuated Control.....	72
With Direct Coupled Actuators.....	38	3-Way Pneumatically-Actuated Control.....	74
Flanged Globe Valves 2 ½ -3"			
With Direct Coupled Actuators.....	42		

Control Valve Applications

		Control Valve Applications												
		Pipe Size (Inches)												
		1/2	3/4	1	1-1/4	1-1/2	2	2-1/2	3	4	5	6	8 ... 20	
Unitary Equipment	Fan Coil Units	Fan Coil/Zone Valve												
		Cartridge Cage Valve												
		Cartridge Globe Valve												
	Unit Ventilators	Fan Coil/Zone Valve												
		Cartridge Cage Valve												
		Cartridge Globe Valve												
	Unit Heaters	Fan Coil/Zone Valve												
		Cartridge Cage Valve												
		Cartridge Globe Valve												
	Reheat Coils	Fan Coil/Zone Valve												
		Cartridge Cage Valve												
		Cartridge Globe Valve												
Blower Coil	Fan Coil/Zone Valve													
	Cartridge Cage Valve													
Convectors	Fan Coil/Zone Valve													
	Cartridge Cage Valve													
	Cartridge Globe Valve													
Radiant Panels	Fan Coil/Zone Valve													
	Cartridge Cage Valve													
	Cartridge Globe Valve													
Chilled Ceiling	Cartridge Cage Valve													
	Cartridge Globe Valve													
Air Handling Units	Humidifiers	Threaded Globe Valve												
		Flanged Globe Valve												
	AHU Heating and Cooling Coils	Threaded Globe Valve												
		Control Ball Valve												
	Central Plant	Thermal Storage	Resilient Seat Butterfly Valve											
			Flanged Globe Valve											
		Cooling Towers	Resilient Seat Butterfly Valve											
			Flanged Globe Valve											
		Boiler System	Resilient Seat Butterfly Valve											
			Flanged Globe Valve											
		Chiller System	Threaded Globe Valve											
			Resilient Seat Butterfly Valve											
Heat Reclaim		Threaded Globe Valve												
		Flanged Globe Valve												
Greenhouse Applications		Threaded Globe Valve												
Heat Exchangers (Steam)		Threaded Globe Valve												

VALVE SELECTION

Control Valve Selection Criteria

2-Way

Attribute	Specification	Unitary				Globe					
		Fan Coil		Cartridge Cage	Cartridge Globe	Threaded			Flanged		
		VU52	VU53	VCzA/B	V58x2	V5011N...	V5011F	V5011G	V5011A	V5011B	VGf2xS
Pipe Size	1/2" [DN15]	•	•	•	•	•					
	3/4" [DN20]	•	•	•	•	•					
	1" [DN25]	•	•	•		•					
	1 1/4" [DN32]			•		•					
	1 1/2" [DN40]					•					
	2" [DN50]					•					
	2 1/2" [DN65]						•	•	•		•
	3" [DN80]						•	•	•		•
	4" [DN100]								•	•	•
	5" [DN125]								•	•	•
6" [DN150]								•	•	•	
Other (maximum size)											
Pipe Fittings	Sweat	•	•	•	•						
	NPT Internal Thread	•	•	•	•	•	•	•			
	Inverted Flare	•	•	•							
	ANSI Flange								•	•	•
Static Pressure	ANSI 125/150					•	•	•	•	•	•
	ANSI 250/300										•
	Other		300 psi	300 psi	230 psi						
Media	Chilled Water	•	•	•	•	•	•	•	•	•	•
	Hot Water	•	•	•	•	•	•	•	•	•	•
	Low Pressure Steam					N1, N3	•	•	•	•	•
	High Pressure Steam					N2		•			•
Flow Capacity, Cv	Multiple ratings per pipe size	•	•	•	•	•	•	•	•	•	•
	One rating/size above 1/2"					•	•	•	•	•	•
Valve Action	Direct Acting ****					N1, N2	•	•			•
	Reverse Acting *****			•	•	N3				•	
	Rotary N.O.	•									
	Rotary N.C.		•								
Flow Characteristic	Equal Percentage				•	•	•		•	•	•
	Modified Equal Percentage			•							
	Linear			•		•		•			•
	Quick Open	•	•	•							
Close-off pressure***	High** (100 psid minimum)				•						
	Medium (40 psid minimum)			•	•						
	Varies with actuator	•	•			•	•	•	•	•	•
Maximum Seat Leakage	ANSI Class III (0.10% Cv max.)				0.02%	0.05%					•
	ANSI Class IV (0.01% Cv max.)								•	•	
	Bubble-tight design			•							
	Other (see product data literature)		33 mL/m				0.5%	0.5%			
Rangeability	High (50:1 minimum)				•	•	•	•	•	•	•
	Medium* (15~50:1)		N/A		•						
	Low (under 15:1)										
Trim	Brass, plated brass, bronze					N3	•		•	•	
	Brass plug /Stainless seat					N1					
	Stainless Steel					N2		•			•
	Resilient materials	•	•	•	•						
In-line Serviceability	Cartridge	•	•	•	•						
	Packing					•	•	•	•	•	•
	Rebuild					•	•	•	•	•	•
Actuation Options	Electronic Modulating			•	•	•	•	•	•	•	•
	Tri-state floating			•	•	•	•	•	•	•	•
	Pulse Width Modulation			•							
	2-position low voltage	•	•	•	0	•	•	•	•	•	•
	2-position line voltage	•	•	•		•	•	•	•	•	•
	Electric Spring Return	•	•		•	•	•	•	•	•	•
	Electronic Fail Safe			•							
	Pneumatic, low pressure				•	•	•	•	•	•	•
	Pneumatic bidirectional (Hi-Pr)										
Pneumatic spring return (Hi-Pr)											

Notes * Best used with supply water reset from outdoor air temperature.

** Can dead-head pumps. Use with VFD-controlled pumps with maximum pressure cut-out

*** Maximum operating differential pressure. Static close-off pressure may be higher. Maximum pressure for quiet service may be less.

**** Stem down to close

***** Stem up to close

Control Valve Selection Criteria

2-Way

VALVE SELECTION

Attribute	Specification	Globe		Control Ball		Butterfly	
		Pressure-Balanced		Threaded	Flanged	Resilient Seat	
		V5862A3	VGf2xP	VBN2	VBF2	VFF1	VFF2
Pipe Size	1/2" [DN15]			•			
	3/4" [DN20]			•			
	1" [DN25]	•		•			
	1 1/4" [DN32]	•		•			
	1 1/2" [DN40]	•		•			
	2" [DN50]			•		•	•
	2 1/2" [DN65]		•	•		•	•
	3" [DN80]		•	•		•	•
	4" [DN100]		•		•	•	•
	5" [DN125]		•		•	•	•
6" [DN150]		•		•	•	•	
Other (maximum size)						20" [DN500]	
Pipe Fittings	Sweat						
	NPT Internal Thread	•		•			
	Inverted Flare						
Static Pressure	ANSI Flange		•		•	•	•
	ANSI 125/150		•		•		
	ANSI 250/300						
Media	Other	230 psi		360 psi		250 psi	
	Chilled Water	•	•	•	•	•	•
	Hot Water	•	•	•	•	•	•
	Low Pressure Steam		•				
Flow Capacity, Cv	High Pressure Steam		•				
	Multiple ratings per pipe size	•		•	•		
Valve Action	One rating/size above 1/2"		•			•	•
	Direct Acting ****	•	•				
	Reverse Acting *****						
	Rotary N.O.			0	0	•	0
Flow Characteristic	Rotary N.C.			•	•		•
	Equal Percentage		•				
	Modified Equal Percentage			•	•	•	•
	Linear	•	•				
Close-off pressure***	Quick Open						
	High** (100 psid minimum)	•	•	•	•	•	•
	Medium (40 psid minimum)					•	•
Maximum Seat Leakage	Varies with actuator						
	ANSI Class III (0.10% Cv max.)						
	ANSI Class IV (0.01% Cv max.)	•	•	•	•	•	•
	Bubble-tight design					•	•
Rangeability	Other (see product data literature)						
	High (50:1 minimum)	•	•	•	•		
	Medium* (15-50:1)			0			
Trim	Low (under 15:1)					•	•
	Brass, plated brass, bronze			•			
	Brass plug /Stainless seat						
	Stainless Steel	•	•	•	•		
In-line Serviceability	Resilient materials					•	•
	Cartridge						
	Packing	•	•	•	•		
Actuation Options	Rebuild				•		
	Electronic Modulating	•	•	•	•	•	•
	Tri-state floating	•	•	•	•	•	•
	Pulse Width Modulation						
	2-position low voltage		•	•	•	Limited	
	2-position line voltage		•	0	0	•	•
	Electric Spring Return	•	•	•	•	Limited	
	Electronic Fail Safe						
	Pneumatic, low pressure		•			Limited	
Pneumatic bidirectional (Hi-Pr)					•	•	
Pneumatic spring return (Hi-Pr)					•	•	

Notes * Best used with supply water reset from outdoor air temperature.
 ** Can dead-head pumps. Use with VFD-controlled pumps with maximum pressure cut-out
 *** Maximum operating differential pressure. Static close-off pressure may be higher. Maximum pressure for quiet service may be less.
 **** Stem down to close
 ***** Stem up to close

Control Valve Selection Criteria

3-Way

Attribute	Specification	Unitary				Globe				
		Fan Coil	Cartridge Cage	Cartridge Globe		Threaded	Flanged			
		VU54	VCzM/N	V58x3	V5863A3	V5013N...	V5013B	V5013C	VGf3xLD	VGf3xEM
Pipe Size	1/2" [DN15]	•	•	•		•				
	3/4" [DN20]	•	•	•		•				
	1" [DN25]	•	•		•	•				
	1 1/4" [DN32]		•		•	•				
	1 1/2" [DN40]				•	•				
	2" [DN50]					•				
	2 1/2" [DN65]						•		•	•
	3" [DN80]						•		•	•
	4" [DN100]						•	•	•	•
	5" [DN125]						•	•	•	•
6" [DN150]						•	•	•	•	
Other (maximum size)										
Pipe Fittings	Sweat	•	•	•						
	NPT Internal Thread	•	•	•	•	•				
	Inverted Flare	•	•							
	ANSI Flange						•	•	•	•
Static Pressure	ANSI 125/150					•	•	•	•	•
	ANSI 250/300								•	•
	Other	300 psi	300 psi	230 psi	230 psi					
Media	Chilled Water	•	•	•	•	•	•	•	•	•
	Hot Water	•	•	•	•	•	•	•	•	•
Flow Capacity, Cv	Multiple ratings per pipe size	•	•	•	•	•				
	One rating/size above 1/2"					•	•	•	•	•
Valve Action	Mixing A-B-AB porting			•	•	•				•
	Mixing A-AB-B porting	•	•							
	Diverting AB-B-A porting							•	•	
	Diverting A-AB-B porting		•							
A-port Flow Characteristic	Equal Percentage			•		•				•
	Modified Equal Percentage		•							
	Linear		•		•		•	•	•	
	Quick Open	•	•							
B-port Flow Characteristic	Modified Equal Percentage									
	Linear		•			•	•	•	•	•
	Linear, Reduced Cv			•	•					
	Total Constant Flow			•	•	•	•	•	•	
Quick Open	•									
Close-off pressure***	High (60 psid minimum)		•	•	•					
	Medium (30 psid minimum)			•						
	Varies with actuator	•				•	•	•	•	•
Maximum Seat Leakage**	ANSI Class III (0.10% Cv max.)			•	•	•			•	
	ANSI Class IV (0.01% Cv max.)						•	•		
	Bubble-tight design		•							
	Other (see product data literature)	33 mL/m								A = 0.5%
Rangeability	High (50:1 minimum)			•	•	•	•	•	•	•
	Medium* (15~50:1)	N/A	•							
	Low (under 15:1)									
Trim	Brass, plated brass, bronze				•	•	•	•		
	Stainless Steel					0			•	•
	Resilient materials	•	•	•						
In-line Serviceability	Cartridge	•	•	•						
	Packing				•	•	•	•	•	•
	Rebuild					•	•	•	•	•
Actuation Options	Electronic Modulating		•	•	•	•	•	•	•	•
	Tri-state floating		•	•	•	•	•	•	•	•
	Pulse Width Modulation		•							
	2-position low voltage	•	•	0	0	•	•	•	•	•
	2-position line voltage	•	•			•	•	•	•	•
	Electric Spring Return	•		•	•	•	•	•	•	•
	Electronic Fail Safe		•							
	Pneumatic, low pressure			•		•	•	•	•	•
	Pneumatic bidirectional (Hi-Pr)									
Pneumatic spring return (Hi-Pr)										

Notes * Best used with supply water reset from outdoor air temperature.

** A port specification

*** A-port maximum operating differential pressure. Static close-off pressure may be higher. Maximum pressure for quiet service may be less.

**** Stem down to close

***** Stem up to close

"Limited" = not available in large sizes

Control Valve Selection Criteria

3-Way

VALVE SELECTION

Attribute	Specification	Control Ball		Butterfly	
		Threaded	Flanged	Resilient Seat	
		VBN3	VBF3	VFF3	VFF6
Pipe Size	1/2" [DN15]	•			
	3/4" [DN20]	•			
	1" [DN25]	•			
	1 1/4" [DN32]	•			
	1 1/2" [DN40]	•			
	2" [DN50]	•		•	•
	2 1/2" [DN65]	•		•	•
	3" [DN80]			•	•
	4" [DN100]		•	•	•
	5" [DN125]		•	•	•
6" [DN150]		•	•	•	
Other (maximum size)				20" [DN500]	
Pipe Fittings	Sweat				
	NPT Internal Thread	•			
	Inverted Flare				
Static Pressure	ANSI Flange		•	•	•
	ANSI 125/150		•		
	ANSI 250/300				
Media	Other	360 psi		250 psi	
	Chilled Water	•	•	•	•
Flow Capacity, Cv	Hot Water	•	•	•	•
	Multiple ratings per pipe size	•	•		
Valve Action	One rating/size above 1/2"			•	•
	Mixing A-B-AB porting	•	•	•	
	Mixing A-AB-B porting				•
	Diverting AB-B-A porting	•	o	•	
A-port Flow Characteristic	Diverting A-AB-B porting				•
	Equal Percentage				
	Modified Equal Percentage	•	•	•	•
B-port Flow Characteristic	Linear				
	Quick Open				
	Modified Equal Percentage			•	•
	Linear				
	Linear, Reduced Cv	•	•		
Close-off pressure***	Total Constant Flow				
	Quick Open				
	High (60 psid minimum)		•	•	•
Maximum Seat Leakage**	Medium (30 psid minimum)	•		•	•
	Varies with actuator				
	ANSI Class III (0.10% Cv max.)				
	ANSI Class IV (0.01% Cv max.)	•	A-port	•	•
Rangeability	Bubble-tight design			•	•
	Other (see product data literature)		B-port		
	High (50:1 minimum)	•	•		
Trim	Medium* (15~50:1)	o			
	Low (under 15:1)			•	•
	Brass, plated brass, bronze	•			
In-line Serviceability	Stainless Steel		•		
	Resilient materials			•	•
	Cartridge				
Actuation Options	Packing	•	•		
	Rebuild		•		
	Electronic Modulating	•	•	•	•
	Tri-state floating	•	•	•	•
	Pulse Width Modulation				
	2-position low voltage	•	•	Limited	
	2-position line voltage	o	o	•	•
	Electric Spring Return	•	•	Limited	
	Electronic Fail Safe				
	Pneumatic, low pressure			Limited	
Pneumatic bidirectional (Hi-Pr)			•	•	
Pneumatic spring return (Hi-Pr)			•	•	

Notes * Best used with supply water reset from outdoor air temperature.
 ** A port specification
 *** A-port maximum operating differential pressure. Static close-off pressure may be higher. Maximum pressure for quiet service may be less.
 **** Stem down to close
 ***** Stem up to close
 "Limited" = not available in large sizes

Fan Coil and Zone Valves

Honeywell Fan Coil and Zone Valves family (VU Series) have withstood the test of time as a reliable and dependable product.

With a Cv range suitable for anything from radiator panels to fan coil units and both normally open and normally closed spring return functions, it's easy to select a model that fits your needs. Additionally you can choose between line voltage or low voltage actuators as well as three different types of pipe fittings: Female NPT, Sweat, and Inverted flare.

Common Features

- Maximum static water pressure: 300 psig
- Ambient temp range: 34-104°F (at 34-200°F medium temperature)
- 3-way valve is diverting type
- Long service life with patented ball seal
- Quick opening / soft closing for optimal 2-position control
- Manual opener

Actuator O.S. Number		VU443A1008	VU443A1024	VU443A1115	VU443A1180	VU443E1009	VU444A1007
Power Supply	Voltage	120 Vac	208 Vac	230 Vac	120 Vac	120 Vac	120 Vac
	Frequency	60 Hz	60 Hz	50 / 60 Hz	60 Hz	60 Hz	60 Hz
	Power (60 Hz)	5 VA	5 VA	5 VA	5 VA	5 VA	5 VA
Control	2-Position SPST	•	•	•	•	•	•
Aux Switch	SPST					2.2 A/120 Vac	
Maximum Timing	Seconds @ 60 Hz, Driving	15	15	15	15	15	15
	Fail Safe	6	6	6	6	6	6
Fail Safe Action		N.C.	N.C.	N.C.	N.C.	N.C.	2-way N.O. 3-way N.O./N.C.
Electrical Connections	Leadwire Length, in.	6	18	6	6	18	6
	1/2 in. flexible conduit hole	•	•	•	•	•	•
Manual Override	(on power failure, auto reset)	•	•	•	•	•	•
Nickel plated motors	Condensing Atmosphere						

Valve Size (inches)	Connection Type	Flow Capacity (Cv)	Valve Action	Valve O.S. Number	2-way Valves Close-off							
1/2"	f NPT	1.0 Cv	Normally Open	VU52N1027								50
	Sweat	1.0 Cv		VU52S2002								50
	f NPT	2.5 Cv		VU52N1035								30
	Sweat	2.5 Cv		VU52S2010								30
	f NPT	3.5 Cv		VU52N1019								20
	Sweat	3.5 Cv		VU52S2028								20
3/4"	f NPT	3.5 Cv		VU52SN1076								20
	Sweat	3.5 Cv		VU52S2036								20
	Sweat	5.0 Cv		VU52S2044								15
	f NPT	8.0 Cv		VU52N1001								10
1"	Sweat	8.0 Cv		VU52S2051								10
	f NPT	8.0 Cv		VU52N1068								10
1/2"	f NPT	1.0 Cv	Normally Closed	VU53N1041	50	50	50	50	50	50		
	Sweat	1.0 Cv		VU53S2018	50	50	50	50	50	50		
	f NPT	2.5 Cv		VU53N1058	30	30	30	30	30	30		
	Sweat	2.5 Cv		VU53S2026	30	30	30	30	30	30		
	Inverted Flare	3.5 Cv		VU53F1024	20	20	20	20	20	20		
	f NPT	3.5 Cv		VU53N1009	20	20	20	20	20	20		
3/4"	Sweat	3.5 Cv		VU53S2034	20	20	20	20	20	20		
	f NPT	3.5 Cv		VU53N1033	20	20	20	20	20	20		
	Sweat	3.5 Cv		VU53S2042	20	20	20	20	20	20		
	f NPT	5.0 Cv		VU53N1066	15	15	15	15	15	15		
	Sweat	5.0 Cv		VU53S2075	15	15	15	15	15	15		
	f NPT	8.0 Cv		VU53N1017	10	10	10	10	10	10		
1"	Sweat	8.0 Cv		VU53S2059	10	10	10	10	10	10		
	f NPT	8.0 Cv		VU53N1026	10	10	10	10	10	10		
1"	Sweat	8.0 Cv		VU53S2000	10	10	10	10	10	10		
	f NPT	8.0 Cv		VU53N1023								
					3-way Valves Close-off							
1/2"	Inverted Flare	4.0 Cv		Mixing	VU54F1022							
	f NPT	4.0 Cv	VU54N1007									20
	Sweat	4.0 Cv	VU54S2008									10
3/4"	f NPT	4.0 Cv	VU54N1031									20
	f NPT	5.0 Cv	VU54N1049									15
	Sweat	5.0 Cv	VU54S2057									15
	f NPT	7.0 Cv	VU54N1015									10
	Sweat	7.0 Cv	VU54S2016									10
1"	f NPT	7.0 Cv	VU54N1023									10
	Sweat	7.0 Cv	VU54S2024									10



2-Way



3-Way

Fan Coil and Zone Valves



VALVE SELECTION

Actuator O.S. Number		VU444A1098	VU444A1106	VU444A1155	VU843A1004	VU843A1087	VU844A1003	VU844A1060
Power Supply	Voltage	227 Vac	230 Vac	120 Vac	24 Vac	24 Vac	24 Vac	24 Vac
	Frequency	60 Hz	50 / 60 Hz	60 Hz	50 / 60 Hz	50 / 60 Hz	50 / 60 Hz	50 / 60 Hz
	Power (60 Hz)	5 VA	5 VA	5 VA	0.32 A	0.32 A	0.32 A	0.32 A
Control	2-Position SPST	•	•	•	•	•	•	•
Aux Switch	SPST							
Maximum Timing	Seconds @ 60 Hz, Driving	15	15	15	15	15	15	15
	Fail Safe	6	6	6	6	6	6	6
Fail Safe Action		2-way N.O. 3-way N.O./N.C.	2-way N.O. 3-way N.O./N.C.	2-way N.O. 3-way N.O./N.C.	N.C.	N.C.	2-way N.O. 3-way N.O./N.C.	2-way N.O. 3-way N.O./N.C.
Electrical Connections	Leadwire Length, in.	18	6	6	6	6	6	6
	1/2 in. flexible conduit hole	•	•	•	•	•	•	•
Manual Override	(on power failure, auto reset)	•	•	•	•	•	•	•
Nickel plated motors	Condensing Atmosphere			•		•		•

Valve Size (inches)	Connection Type	Flow Capacity (Cv)	Valve Action	Valve O.S. Number	2-way Valves Close-off												
2-Way	1/2"	f NPT	1.0 Cv	Normally Open	VU52N1027	50	50	50						50	50		
		Sweat	1.0 Cv		VU52S2002	50	50	50						50	50		
		f NPT	2.5 Cv		VU52N1035	30	30	30						30	30		
		Sweat	2.5 Cv		VU52S2010	30	30	30						30	30		
		f NPT	3.5 Cv		VU52N1019	20	20	20						20	20		
		Sweat	3.5 Cv		VU52S2028	20	20	20						20	20		
	3/4"	f NPT	3.5 Cv		Normally Open	VU52SN1076	20	20	20						20	20	
		Sweat	3.5 Cv			VU52S2036	20	20	20						20	20	
		Sweat	5.0 Cv			VU52S2044	15	15	15						15	15	
		f NPT	8.0 Cv			VU52N1001	10	10	10						10	10	
		Sweat	8.0 Cv			VU52S2051	10	10	10						10	10	
		f NPT	8.0 Cv			VU52N1068	10	10	10						10	10	
	3-Way	1/2"	f NPT		1.0 Cv	Normally Closed	VU53N1041					50	50				
			Sweat		1.0 Cv		VU53S2018					50	50				
			f NPT		2.5 Cv		VU53N1058					30	30				
Sweat			2.5 Cv	VU53S2026						30	30						
Inverted Flare			3.5 Cv	VU53F1024						20	20						
f NPT			3.5 Cv	VU53N1009						20	20						
Sweat			3.5 Cv	VU53S2034						20	20						
3/4"		f NPT	3.5 Cv	Normally Closed	VU53N1033						20	20					
		Sweat	3.5 Cv		VU53S2042						20	20					
		f NPT	5.0 Cv		VU53N1066						15	15					
		Sweat	5.0 Cv		VU53S2075						15	15					
		f NPT	8.0 Cv		VU53N1017						10	10					
		Sweat	8.0 Cv		VU53S2059						10	10					
1"		f NPT	8.0 Cv	Normally Closed	VU53N1026						10	10					
		Sweat	8.0 Cv		VU53S2000						10	10					
Valve Size (inches)	Flow Capacity (Cv)	Valve Action	Connection Type	Valve O.S. Number	3-way Valves Close-off												
3-Way	1/2"	Inverted Flare	4.0 Cv	Mixing	VU54F1022	20	20	20						20	20		
		f NPT	4.0 Cv		VU54N1007	20	20	20						20	20		
		Sweat	4.0 Cv		VU54S2008	10	10	10						10	10		
	3/4"	f NPT	4.0 Cv		VU54N1031	20	20	20							20	20	
		f NPT	5.0 Cv		VU54N1049	15	15	15							15	15	
		Sweat	5.0 Cv		VU54S2057	15	15	15							15	15	
		f NPT	7.0 Cv		VU54N1015	10	10	10							10	10	
		Sweat	7.0 Cv		VU54S2016	10	10	10							10	10	
		1"	f NPT		7.0 Cv	VU54N1023	10	10	10							10	10
			Sweat		7.0 Cv	VU54S2024	10	10	10							10	10

Cartridge Cage Valves

Honeywell Cartridge Cage Valves family (VC Series) are highly serviceable and completely rebuildable.

Select from 2-position (both low and line voltage), floating, and modulating actuators, and fail-safe actuators with configurable open/closed functionality on power failure depending on the application. Since these valves are not sensitive to flow direction; they can do both mixing and diverting without changing anything except the piping.



Actuator O.S. Number		Non-Fail Safe						
		VC6834ZZ11	VC6934ZZ11	VC7934ZZ11	VC4011ZZ11	VC4013ZZ11	VC8114ZZ11	VC8714ZZ11
Power Supply	Voltage	24 Vac	24 Vac	24 Vac	100-130 Vac	200-240 Vac	24 Vac	24 Vac
	Frequency	50/60 Hz	50/60 Hz	50/60 Hz	50/60 Hz	50/60 Hz	60 Hz	60 Hz
	Power	6 VA	6 VA	6 VA	6 VA	6 VA	6 VA	6 VA
	Control	2-10 Vdc						
	4-20 mA (external 500 Ohm resistor)			•				
	Floating	•	•					
	2-Position SPDT	•	•					
	2-Position SPST				•	•	•	•
	Pulse Width Modulation							
Aux Switch	SPDT Class II	2.2 A						2.2 A
Fail Safe Action		Stay in Place	Stay in Place	Stay in Place	Stay in Place	Stay in Place	Stay in Place	Stay in Place
Reversible Operation	Wiring Change	•	•					
	DIP Switch							
Stroke Timing	Seconds @ 60 Hz (Drive)	120	120	120	6	6	6	6
	Fail Safe							
Electrical Connection	Cable length, in.	60	60	60	39.4	39.4	60	60
	Plenum-rated cable	•	•	•			•	•
	1/2 in. flexible conduit adapter	•	•	•			•	•

Valve Size (inches)	Connection Type	Flow Capacity (Cv)	Flow Characteristic	Valve O.S. Number								
1/2"	f NPT	0.7	Modified Equal %	VCZBB3500	VCZBB3500	VCZBB3500						
	Sweat	0.7		VCZAA3500	VCZAA3500	VCZAA3500						
	f NPT	1.3		VCZBB3600	VCZBB3600	VCZBB3600						
	Sweat	1.3		VCZAA3600	VCZAA3600	VCZAA3600						
	Sweat	1.9		VCZAA3800	VCZAA3800	VCZAA3800						
	f NPT	1.9		VCZBB3800	VCZBB3800	VCZBB3800						
	Sweat	2.3		VCZAA3400	VCZAA3400	VCZAA3400						
	f NPT	2.3		VCZBB3400	VCZBB3400	VCZBB3400						
	f NPT	3.5	Linear	VCZBB3100	VCZBB3100	VCZBB3100	VCZBB1100	VCZBB1100	VCZBB1100	VCZBB1100		
	Sweat	3.5	Linear	VCZAA3100	VCZAA3100	VCZAA3100	VCZAA1100	VCZAA1100	VCZAA1100	VCZAA1100		
3/4"	f NPT	3.9	Modified Equal %	VCZAL3400	VCZAL3400	VCZAL3400						
	Sweat	3.9	Modified Equal %	VCZAM3400	VCZAM3400	VCZAM3400						
	f NPT	4.7	Linear	VCZAL3100	VCZAL3100	VCZAL3100	VCZAL1100	VCZAL1100	VCZAL1100	VCZAL1100		
	Sweat	4.7	Linear	VCZAM3100	VCZAM3100	VCZAM3100	VCZAM1100	VCZAM1100	VCZAM1100	VCZAM1100		
1"	f NPT	4.2	Modified Equal %	VCZAR3400	VCZAR3400	VCZAR3400						
	Sweat	4.2	Modified Equal %	VCZAS3400	VCZAS3400	VCZAS3400						
	f NPT	6.6	Linear	VCZAR3100	VCZAR3100	VCZAR3100	VCZAR1100	VCZAR1100	VCZAR1100	VCZAR1100		
	Sweat	6.6		VCZAS3100	VCZAS3100	VCZAS3100	VCZAS1100	VCZAS1100	VCZAS1100	VCZAS1100		
1-1/4"	f NPT	7	Linear	VCZBD3100	VCZBD3100	VCZBD3100	VCZBD1100	VCZBD1100	VCZBD1100	VCZBD1100		
	Sweat	7		VCZBE3100	VCZBE3100	VCZBE3100	VCZBE1100	VCZBE1100	VCZBE1100	VCZBE1100		

2-Way

3-Way Mixing/ Diverting



Cartridge Cage Valves

Common Features

- 2-way straight-through or 3-way mixing/diverting body configurations
- Corrosion resistant, engineered plastic actuator housing
- 60 psid close-off on all models
- Fast acting 2-position actuator with soft close technology
- Position indicator/manual override lever standard
- Replaceable cartridge rebuilds valve to factory specifications without removing valve body from piping
- 300 psi operating pressure
- Combination position indicator/manual flush-and-fill manual lever on all actuators



Honeywell's Cartridge Cage Valves feature a field replaceable cartridge for all working parts

		Fail Safe	
Actuator O.S. Number		VC6936ZZ11-530	VC7936ZZ11-529
Power Supply	Voltage	24 Vac	24 Vac
	Frequency	50/60 Hz	50/60 Hz
	Power	12 VA	12 VA
Control	2-10 Vdc		•
	4-20 mA (external 500 Ohm resistor)		•
	Floating	•	•
	2-Position SPDT	•	•
	2-Position SPST		•
	Pulse Width Modulation	•	•
Aux Switch	SPDT Class II		
Fail Safe Action		Electronic NO/NC	Electronic NO/NC
Reversible Operation	Wiring Change	•	•
	DIP Switch		•
Stroke Timing	Seconds @ 60 Hz (Drive)	120	60 / 120
	Fail Safe	12	12
Electrical Connection	Cable length, in.	60	60
	Plenum-rated cable	•	•
	1/2 in. flexible conduit adapter	•	•

Valve Size (inches)	Connection Type	Flow Capacity (Cv)	Flow Characteristic	Y-pack O.S. Number		Replacement Cartridge Floating / Modulating	Replacement Cartridge Electronic Fail Safe		
				Y-pack O.S. Number	Y-pack O.S. Number				
2-Way	1/2"	f NPT	0.7	Modified Equal %	VC6936BB1500	VC7936BB1500	VCZZ3500	VCZZ1500	
		Sweat	0.7		VC6936AA1500	VC7936AA1500	VCZZ3500	VCZZ1500	
		f NPT	1.3		VC6936BB1600	VC7936BB1600	VCZZ3600	VCZZ1600	
		Sweat	1.3		VC6936AA1600	VC7936AA1600	VCZZ3600	VCZZ1600	
		Sweat	1.9		VC6936AA1800	VC7936AA1800	VCZZ3800	VCZZ1800	
		f NPT	1.9		VC6936BB1800	VC7936BB1800	VCZZ3800	VCZZ1800	
		Sweat	2.3		VC6936AA1400	VC7936AA1400	VCZZ3400	VCZZ1400	
		f NPT	2.3		VC6936BB1400	VC7936BB1400	VCZZ3400	VCZZ1400	
	f NPT	3.5	Linear	VC6936BB1100	VC7936BB1100	VCZZ3100	VCZZ1100*		
	Sweat	3.5	Linear	VC6936AA1100	VC7936AA1100	VCZZ3100	VCZZ1100*		
	3/4"	f NPT	3.9	Modified Equal %	VC6936AL1400	VC7936AL1400	VCZZ3400	VCZZ1400	
		Sweat	3.9	Modified Equal %	VC6936AM1400	VC7936AM1400	VCZZ3400	VCZZ1400	
		f NPT	4.7	Linear	VC6936AL1100	VC7936AL1100	VCZZ3100	VCZZ1100*	
		Sweat	4.7	Linear	VC6936AM1100	VC7936AM1100	VCZZ3100	VCZZ1100*	
	1"	f NPT	4.2	Modified Equal %	VC6936AR1400	VC7936AR1400	VCZZ3400	VCZZ1400	
		Sweat	4.2	Modified Equal %	VC6936AS1400	VC7936AS1400	VCZZ3400	VCZZ1400	
f NPT		6.6	Linear	VC6936AR1100	VC7936AR1100	VCZZ3100	VCZZ1100*		
Sweat		6.6		VC6936AS1100	VC7936AS1100	VCZZ3100	VCZZ1100*		
1-1/4"	f NPT	7	Linear	VC6936BD1100	VC7936BD1100	VCZZ3100	VCZZ1100*		
	Sweat	7		VC6936BE1100	VC7936BE1100	VCZZ3100	VCZZ1100*		
3-Way Mixing/ Diverting	1/2"	f NPT	0.7	Modified Equal %	VC6936NB6500	VC7936NB6500	VCZZ7500	VCZZ6500	
		Sweat	0.7		VC6936MA6500	VC7936MA6500	VCZZ7500	VCZZ6500	
		f NPT	1.5		VC6936NB6600	VC7936NB6600	VCZZ7600	VCZZ6600	
		Sweat	1.5		VC6936MA6600	VC7936MA6600	VCZZ7600	VCZZ6600	
		f NPT	1.5		VC6936NB6800	VC7936NB6800	VCZZ7800	VCZZ6800	
		Sweat	1.5		VC6936MA6800	VC7936MA6800	VCZZ7800	VCZZ6800	
		f NPT	2.7		VC6936NB6400	VC7936NB6400	VCZZ7400	VCZZ6400	
		Sweat	2.7		VC6936MA6400	VC7936MA6400	VCZZ7400	VCZZ6400	
		f NPT	3.7		Linear	VC6936NB6100	VC7936NB6100	VCZZ7100	VCZZ6100*
		Sweat	3.7		Linear	VC6936MA6100	VC7936MA6100	VCZZ7100	VCZZ6100*
	3/4"	f NPT	4.2	Modified Equal %	VC6936MK6400	VC7936MK6400	VCZZ7400	VCZZ6400	
		Sweat	4.2	Modified Equal %	VC6936ML6400	VC7936ML6400	VCZZ7400	VCZZ6400	
		f NPT	6.6	Linear	VC6936MK6100	VC7936MK6100	VCZZ7100	VCZZ6100*	
		Sweat	6.6		VC6936ML6100	VC7936ML6100	VCZZ7100	VCZZ6100*	
	1"	f NPT	8.3	Linear	VC6936MR6100	VC7936MR6100	VCZZ7100	VCZZ6100*	
		Sweat	8.3		VC6936MS6100	VC7936MS6100	VCZZ7100	VCZZ6100*	
	1-1/4"	f NPT	9	Linear	VC6936ND6100	VC7936ND6100	VCZZ7100	VCZZ6100*	
		Sweat	9		VC6936NE6100	VC7936NE6100	VCZZ7100	VCZZ6100*	

* Also applies to 2-position valve-actuator applications

Cartridge Globe Valves

For more than 50 years, Honeywell has manufactured the V58 series of premium Cartridge Globe Valves. The compact size and replacement capabilities make it a great choice for controlling modulating unitary equipment.



Valves 1" and larger feature a pressure balanced design with enhanced close-off (levels).

Common Features

- Maximum static pressure 235 psi
- Long stroke allows for a wide range of control
- Leakage rate: 0.02% of Cv
- Insert replacement tool allows for the valve cartridge to be replaced or changed without draining the system (1/2" and 3/4" models only)
- Brass body and stainless steel stem
- Threaded plastic valve cover/manual handle allows for manual operation
- Corrosion resistant

Actuator O.S. Number		Non-Fail Safe			
		M6410A1029	M6410A3017	M7410F1000	M7410F3006
Power Supply	Voltage	24 Vac	24 Vac	24 Vac	24 Vac
	Frequency	50/60 Hz	50/60 Hz	50/60 Hz	50/60 Hz
	Power	0.7 VA	0.7 VA	1.4 VA	1.4 VA
	Stem Force (lb.)	40.5	67.5	40.5	67.5
Control	2-Position SPDT	•	•		
	Floating	•	•		
	0(2)-10 Vdc			DIP Switch	DIP Switch
	4-20 mA (external 500 Ohm resistor)			•	•
	Pneumatic Spring Range				
Fail Safe Action		Stay in Place	Stay in Place	Stay in Place	Stay in Place
Reversible Operation	Wiring Change	•	•		
	DIP Switch			•	•
Stroke Timing	Seconds @ 60 Hz (Drive)	125	125	125	125
	Fail Safe				
Manual Override	(Use valve dust cap)	•	•	•	•
Position Indicator		•	•	•	•
Electrical Connection	Cable length, in.	36	36	36	36
	Plenum-rated Cable	•	•	•	•
	Screw terminals				
	1/2 in. flexible conduit hub	•	•	•	•



2-Way

Valve Size (inches)	Pipe Connection Type	Flow Capacity (Cv)	Flow Characteristic	Valve Closes	Valve O.S. Number	Close-off Pressure, psid			
1/2"	f NPT	0.19	Equal%	Stem Down ²	V5862A2005	232		232	
	Sweat	0.19			V5852A2007	232		232	
	f NPT	0.29			V5862A2013	232		232	
	Sweat	0.29			V5852A2015	232		232	
	f NPT	0.47			V5862A2021	232		232	
	Sweat	0.47			V5852A2023	232		232	
	f NPT	0.74			V5862A2039	232		232	
	Sweat	0.74			V5852A2031	232		232	
	f NPT	1.2			V5862A2047	174		174	
	Sweat	1.2			V5852A2049	174		174	
	f NPT	1.9			V5862A2054	174		174	
	Sweat	1.9			V5852A2056	174		174	
	f NPT	2.9			V5862A2062	58		58	
	Sweat	2.9			V5852A2064	58		58	
1"	f NPT	5.5	Linear	Stem Up	V5862A3003		232		232
	f NPT	7.8			V5862A3011		232		232
	f NPT	11			V5862A3029		232		232
	f NPT	18			V5862A3037		174		174
1-1/2"	f NPT	25			V5862A3045		145		145



3-Way

Valve Size (inches)	Pipe Connection Type	Flow Capacity (Cv)	Flow Characteristic	Valve Closes	Valve O.S. Number	Close-off Pressure, psid						
1/2"	f NPT	0.29	A-AB Equal%, B-AB Linear	Stem Up	V5863A2004	116		116				
	Sweat	0.29			V5853A2006	116		116				
	f NPT	0.47			V5863A2012	116		116				
	Sweat	0.47			V5853A2014	116		116				
	f NPT	0.74			V5863A2020	36		36				
	Sweat	0.74			V5853A2022	36		36				
	f NPT	1.2			V5863A2038	36		36				
	Sweat	1.2			V5853A2030	36		36				
	f NPT	1.9			V5863A2046	34		34				
	Sweat	1.9			V5853A2048	34		34				
	f NPT	2.9			V5863A1006	34		34				
	Sweat	2.9			V5853A1008	34		34				
	f NPT	4.9			V5863A1014	34		34				
	Sweat	4.9			V5853A1016	34		34				
3/4"	f NPT	2.9	Linear	Stem Up	V5863A2053	7.25		7.25				
	Sweat	2.9			V5853A2055	7.25		7.25				
	f NPT	4.9			V5863A2061	7.25		7.25				
	Sweat	4.9			V5853A2063	7.25		7.25				
	f NPT	5.5			V5863A3002		232		232			
	f NPT	7.8			V5863A3010		232		232			
	f NPT	11			V5863A3028		232		232			
	f NPT	18			V5863A3036		174		174			
	1-1/2"	f NPT			25			V5863A3044		145		145

Notes: Maximum coil-bypass pressure difference is 7 psi when used with electric actuators.

¹ B port Cv is 20% less

² Fail safe position for 1/2" and 3/4" 2-way is Normally Open with Mx435 and MP958 spring return actuators. All other valves fail safe closed.

Download from www.Somanuals.com. All Manuals Search And Download.

Cartridge Globe Valves



Actuator O.S. Number		Fail Safe				Pneumatic		
		M6435A1004	M6435A3000	M7435F1001	M7435F3007	MP958A1009	MP958A1017	MP958A1025
Power Supply	Voltage	24 Vac	24 Vac	24 Vac	24 Vac			
	Frequency	50/60 Hz	50/60 Hz	50/60 Hz	50/60 Hz			
	Power	10 VA	10 VA	5 VA	5 VA			
Control	Stem Force (lb.)	40.5	90	40.5	90			
	2-Position SPDT	•	•					
	Floating	•	•					
	0(2)-10 Vdc			DIP Switch	DIP Switch			
	4-20 mA (external 500 Ohm resistor)			•	•			
Pneumatic Spring Range						2-5 psi	3-10 psi	8-11 psi
Fail Safe Action		2-way N.O. 3-way N.C.	N.C.	2-way N.O. 3-way N.C.	N.C.	2-way N.O. 3-way N.C.	2-way N.O. 3-way N.C.	2-way N.O. 3-way N.C.
	Wiring Change	•	•					
Reversible Operation	DIP Switch			•	•			
	Seconds @ 60 Hz (Drive)	50	50	50	50			
Stroke Timing	Fail Safe	10	10	10	10			
	(Use valve dust cap)	•	•	•	•	•	•	•
Position Indicator		•	•	•	•			
Electrical Connection	Cable length, in.							
	Plenum-rated Cable							
	Screw terminals	•	•	•	•			
		1/2 in. flexible conduit hub	•	•	•	•		

Valve Size (inches)	Pipe Connection Type	Flow Capacity (Cv)	Flow Characteristic	Valve Closes	Valve O.S. Number	Close-off Pressure, psid				A-port Close-off Pressure, psid Full air pressure*		Replacement Insert ³		
2-Way	1/2"	f NPT	Equal%	Stem Down ²	V5862A2005	232		232		232	232	232	0902812	
		Sweat			V5852A2007	232		232		232	232	232	0902812	
		f NPT			V5862A2013	232		232		232	232	232	0902811	
		Sweat			V5852A2015	232		232		232	232	232	0902811	
		f NPT			V5862A2021	232		232		232	232	232	0902810	
		Sweat			V5852A2023	232		232		232	232	232	0902810	
	f NPT	V5862A2039	232		232		232	232	232	0902809				
	Sweat	V5852A2031	232		232		232	232	232	0902809				
	f NPT	V5862A2047	174		174		232	140	120	0902808				
	Sweat	V5852A2049	174		174		232	140	120	0902808				
	f NPT	V5862A2054	174		174		232	140	120	0902807				
	Sweat	V5852A2056	174		174		232	140	120	0902807				
	f NPT	V5862A2062	58		58		90	50	40	0902814				
	Sweat	V5852A2064	58		58		90	50	40	0902814				
	f NPT	V5862A2070	58		58		90	50	40	0902815				
	Sweat	V5852A2072	58		58		90	50	40	0902815				
	f NPT	V5862A3003			232			232			0903827			
	f NPT	V5862A3011			232		232	232			0903827			
f NPT	V5862A3029			232		232	232			0903827				
1-1/4"	f NPT	18	Linear	Stem Up	V5862A3037		174		174			0903828		
1-1/2"	f NPT	25			V5862A3045		145		145			0903829		
Valve Size (inches)	Pipe Connection Type	Flow Capacity (Cv)	Flow Characteristic	Valve Closes	Valve O.S. Number	Close-off Pressure, psid				A-port Close-off Pressure, psid Full air pressure*		Replacement Insert ³		
3-Way	1/2"	f NPT	A-AB Equal%, B-AB Linear	Stem Up	V5863A2004	116		116		20	80	232	0902821	
		Sweat			V5853A2006	116		116		20	80	232	0902821	
		f NPT			V5863A2012	116		116		20	80	232	0902822	
		Sweat			V5853A2014	116		116		20	80	232	0902822	
		f NPT			V5863A2020	36		36		20	80	232	0902823	
		Sweat			V5853A2022	36		36		20	80	232	0902823	
		f NPT			V5863A2038	36		36		N/A	10	100	0902824	
		Sweat			V5853A2030	36		36		N/A	10	100	0902824	
		f NPT			V5863A2046	34		34		N/A	10	100	0902825	
		Sweat			V5853A2048	34		34		N/A	10	100	0902825	
		f NPT			V5863A1006	34		34						0902826
		Sweat			V5853A1008	34		34						0902826
	f NPT	V5863A1014	34		34						0902827			
	Sweat	V5853A1016	34		34						0902827			
	f NPT	V5863A2053	7.25		7.25		N/A	N/A	35		0902818			
	Sweat	V5853A2055	7.25		7.25		N/A	N/A	35		0902818			
	f NPT	V5863A2061	7.25		7.25		N/A	N/A	35		0902819			
	Sweat	V5853A2063	7.25		7.25		N/A	N/A	35		0902819			
f NPT	V5863A3002						232				0903827			
f NPT	V5863A3010						232				0903827			
f NPT	V5863A3028						232				0903827			
1-1/4"	f NPT	18	Linear		V5863A3036		174		174			0903828		
1-1/2"	f NPT	25			V5863A3044		145		145			0903829		

Notes: *20 psi for 2-way; 0 psi for 3-way
²B-port Close-off of 3-way valves is the same as A-port in 2-way valves
³Insert determines Cv for 1/2" and 3/4" bodies. Grouped inserts are interchangeable.

Control Ball Valves 1/2- 3"

2-Way NPT NEMA 2

Honeywell's Control Ball Valve product lines (VBN and VBF) feature the largest Cv range in the industry. A patented seat design allows for lower torque actuators, while a single spring return actuator may be used for up to a 70 psid differential pressure close-off on up to a 6" connection size.

The VBN family features a unique field replaceable stem assembly.

Common Features

- Max static pressure 360 psi (250°F)
- Medium: Water/glycol solutions up to 50%.
- Temperature range: -22 to +250°F
- Field configurable open or closed fail-safe position
- ANSI class IV leakage (0.01% of Cv)

VBN2 (Two-way)

- Equal % flow insert. Linear with full port. (Largest Cv valve in each valve size is full port), as noted
- Nickel-chrome plated brass or 316 stainless steel ball and stem



NEED TO PHOTOSHOP



2-Way

Actuator Features		Non-fail Safe			
Actuator O.S. Number		MN6105A1011	MN6105A1011	MN7505A2001	MN7505A2001
Power Supply	Voltage	24 Vac	24 Vac	24 Vac	24 Vac
	Frequency	50 / 60 Hz	50 / 60 Hz	50 / 60 Hz	50 / 60 Hz
Actuator Torque	Power	5 VA	5 VA	5 VA	5 VA
	(lb.-in.)	44	44	44	44
Control	(0)2-10 Vdc			•	•
	4-20 mA (external 500 Ohm Resistor)			•	•
	Floating	•	•	•	•
	Two-Position SPDT	•	•	•	•
	Two-Position SPST			•	•
Fail Safe Action		Stay in Place	Stay in Place	Stay in Place	Stay in Place
Normal Position (no signal)		Closed	Closed	Closed	Closed
Actuator Stroke	(degrees)	95° ± 3°	95° ± 3°	95° ± 3°	95° ± 3°
Timing	(seconds)	90	90	90	90
Aux Switch	2 x SPDT Add-on	SSW2	SSW2	SW2-US	SW2-US
Feedback	2-10 Vdc Built In	-	-	•	•
Valve Features	Trim	Nickel-Plated Brass	Stainless Steel	Nickel-Plated Brass	Stainless Steel

Valve Size (inches)	Cv	Close-off Differential Pressure (psi)	Valve O.S. Number			
1/2"	0.38	130	VBN2AB3P0A	VBN2AB3S0A	VBN2AB3P0B	VBN2AB3S0B
	0.68		VBN2AD3P0A	VBN2AD3S0A	VBN2AD3P0B	VBN2AD3S0B
	1.3		VBN2AE3P0A	VBN2AE3S0A	VBN2AE3P0B	VBN2AE3S0B
	2		VBN2AF3P0A	VBN2AF3S0A	VBN2AF3P0B	VBN2AF3S0B
	2.6		VBN2AG3P0A	VBN2AG3S0A	VBN2AG3P0B	VBN2AG3S0B
	4.7		VBN2AH3P0A	VBN2AH3S0A	VBN2AH3P0B	VBN2AH3S0B
	8		VBN2AJ3P0A	VBN2AJ3S0A	VBN2AJ3P0B	VBN2AJ3S0B
	11.7*		VBN2AK3P0A	VBN2AK3S0A	VBN2AK3P0B	VBN2AK3S0B
3/4"	0.31	130	VBN2BB3P0A	VBN2BB3S0A	VBN2BB3P0B	VBN2BB3S0B
	0.63		VBN2BD3P0A	VBN2BD3S0A	VBN2BD3P0B	VBN2BD3S0B
	1.2		VBN2BE3P0A	VBN2BE3S0A	VBN2BE3P0B	VBN2BE3S0B
	2.5		VBN2BG3P0A	VBN2BG3S0A	VBN2BG3P0B	VBN2BG3S0B
	4.3		VBN2BH3P0A	VBN2BH3S0A	VBN2BH3P0B	VBN2BH3S0B
	7.4		VBN2BJ3P0A	VBN2BJ3S0A	VBN2BJ3P0B	VBN2BJ3S0B
	10.1		VBN2BK3P0A	VBN2BK3S0A	VBN2BK3P0B	VBN2BK3S0B
	14.7*		VBN2BL3P0A	VBN2BL3S0A	VBN2BL3P0B	VBN2BL3S0B
1"	29*	130	VBN2BM3P0A	VBN2BM3S0A	VBN2BM3P0B	VBN2BM3S0B
	4.4		VBN2CH3P0A	VBN2CH3S0A	VBN2CH3P0B	VBN2CH3S0B
	9		VBN2CJ3P0A	VBN2CJ3S0A	VBN2CJ3P0B	VBN2CJ3S0B
	15.3		VBN2CL3P0A	VBN2CL3S0A	VBN2CL3P0B	VBN2CL3S0B
	26		VBN2CM3P0A	VBN2CM3S0A	VBN2CM3P0B	VBN2CM3S0B
	44*		VBN2CN3P0A	VBN2CN3S0A	VBN2CN3P0B	VBN2CN3S0B
	54*		VBN2CP3P0A	VBN2CP3S0A	VBN2CP3P0B	VBN2CP3S0B
	1-1/4"		4.4	100	VBN2DH3P0A	VBN2DH3S0A
8.3		VBN2DJ3P0A	VBN2DJ3S0A		VBN2DJ3P0B	VBN2DJ3S0B
14.9		VBN2DK3P0A	VBN2DK3S0A		VBN2DK3P0B	VBN2DK3S0B
25		VBN2DL3P0A	VBN2DL3S0A		VBN2DL3P0B	VBN2DL3S0B
37		VBN2DM3P0A	VBN2DM3S0A		VBN2DM3P0B	VBN2DM3S0B
41*		VBN2DN3P0A	VBN2DN3S0A		VBN2DN3P0B	VBN2DN3S0B
102*		VBN2DS3P0A	VBN2DS3S0A		VBN2DS3P0B	VBN2DS3S0B
1-1/2"		23	100		VBN2EL3P0A	VBN2EL3S0A
	30	VBN2EM3P0A		VBN2EM3S0A	VBN2EM3P0B	VBN2EM3S0B
	41	VBN2EN3P0A		VBN2EN3S0A	VBN2EN3P0B	VBN2EN3S0B
	74*	VBN2ER3P0A		VBN2ER3S0A	VBN2ER3P0B	VBN2ER3S0B
	172*	VBN2E13P0A		VBN2E13S0A	VBN2E13P0B	VBN2E13S0B
	42	VBN2FN3P0A		VBN2FN3S0A	VBN2FN3P0B	VBN2FN3S0B
	57	VBN2FP3P0A		VBN2FP3S0A	VBN2FP3P0B	VBN2FP3S0B
	71	VBN2FR3P0A		VBN2FR3S0A	VBN2FR3P0B	VBN2FR3S0B
2"	100	100	VBN2FS3P0A	VBN2FS3S0A	VBN2FS3P0B	VBN2FS3S0B
	108*		VBN2FT3P0A	VBN2FT3S0A	VBN2FT3P0B	VBN2FT3S0B
	210		VBN2F13P0A	VBN2F13S0A	VBN2F13P0B	VBN2F13S0B
	266*		VBN2F23P0A	VBN2F23S0A	VBN2F23P0B	VBN2F23S0B
	45		VBN2GN3P0A	VBN2GN3S0A	VBN2GN3P0B	VBN2GN3S0B
	55		VBN2GP3P0A	VBN2GP3S0A	VBN2GP3P0B	VBN2GP3S0B
	72		VBN2GR3P0A	VBN2GR3S0A	VBN2GR3P0B	VBN2GR3S0B
	101		VBN2GS3P0A	VBN2GS3S0A	VBN2GS3P0B	VBN2GS3S0B
2-1/2"	162	100	VBN2GU3P0A	VBN2GU3S0A	VBN2GU3P0B	VBN2GU3S0B
	202*		VBN2G13P0A	VBN2G13S0A	VBN2G13P0B	VBN2G13S0B
	49		VBN2HN3P0A	VBN2HN3S0A	VBN2HN3P0B	VBN2HN3S0B
	63		VBN2HP3P0A	VBN2HP3S0A	VBN2HP3P0B	VBN2HP3S0B
	82		VBN2HR3P0A	VBN2HR3S0A	VBN2HR3P0B	VBN2HR3S0B
	124		VBN2HT3P0A	VBN2HT3S0A	VBN2HT3P0B	VBN2HT3S0B
	145*		VBN2HU3P0A	VBN2HU3S0A	VBN2HU3P0B	VBN2HU3S0B

Full port ball. No flow characterizing insert.

Control Ball Valves 1/2-3"

2-Way NPT NEMA 2

Actuator Features		Fail Safe					
Actuator O.S. Number		MS8105A1030	MS8105A1030	MS7505A2030	MS7505A2030	Valve Only	Valve Only
Power Supply	Voltage	24 Vac	24 Vac	24 Vac	24 Vac		
	Frequency	50 / 60 Hz	50 / 60 Hz	50 / 60 Hz	50 / 60 Hz		
	Power	8VA	8VA	7.5 VA	7.5 VA		
Actuator Torque	(lb.-in.)	44	44	44	44		
Control	(0)2-10 Vdc			•	•		
	4-20 mA (external 500 Ohm Resistor)			•	•		
	Floating			•	•		
	Two-Position SPDT			•	•		
	Two-Position SPST	•	•	•	•		
Fail Safe Action		Closed*	Closed*	Closed*	Closed*		
Normal Position (no signal)		Closed*	Closed*	Closed*	Closed*		
Actuator Stroke	(degrees)	95° ± 3°	95° ± 3°	95° ± 3°	95° ± 3°		
Timing	(seconds)	45	45	90	90		
Aux Switch	2 x SPDT Add-on						
Feedback	2-10 Vdc Built In			•	•		
Valve Features	Trim	Nickel-Plated Brass	Stainless Steel	Nickel-Plated Brass	Stainless Steel	Nickel-Plated Brass	Stainless Steel

Valve Size (inches)	Cv	Close-off Differential Pressure (psi)	Valve O.S. Number					
			1	2	3	4		
1/2"	0.38	130	VBN2AB3P0C	VBN2AB3S0C	VBN2AB3P0D	VBN2AB3S0D	VBN2AB3P0X	VBN2AB3S0X
	0.68		VBN2AD3P0C	VBN2AD3S0C	VBN2AD3P0D	VBN2AD3S0D	VBN2AD3P0X	VBN2AD3S0X
	1.3		VBN2AE3P0C	VBN2AE3S0C	VBN2AE3P0D	VBN2AE3S0D	VBN2AE3P0X	VBN2AE3S0X
	2		VBN2AF3P0C	VBN2AF3S0C	VBN2AF3P0D	VBN2AF3S0D	VBN2AF3P0X	VBN2AF3S0X
	2.6		VBN2AG3P0C	VBN2AG3S0C	VBN2AG3P0D	VBN2AG3S0D	VBN2AG3P0X	VBN2AG3S0X
	4.7		VBN2AH3P0C	VBN2AH3S0C	VBN2AH3P0D	VBN2AH3S0D	VBN2AH3P0X	VBN2AH3S0X
	8		VBN2AJ3P0C	VBN2AJ3S0C	VBN2AJ3P0D	VBN2AJ3S0D	VBN2AJ3P0X	VBN2AJ3S0X
	11.7*		VBN2AK3P0C	VBN2AK3S0C	VBN2AK3P0D	VBN2AK3S0D	VBN2AK3P0X	VBN2AK3S0X
	0.31		VBN2BB3P0C	VBN2BB3S0C	VBN2BB3P0D	VBN2BB3S0D	VBN2BB3P0X	VBN2BB3S0X
	0.63		VBN2BD3P0C	VBN2BD3S0C	VBN2BD3P0D	VBN2BD3S0D	VBN2BD3P0X	VBN2BD3S0X
3/4"	1.2	VBN2BE3P0C	VBN2BE3S0C	VBN2BE3P0D	VBN2BE3S0D	VBN2BE3P0X	VBN2BE3S0X	
	2.5	VBN2BG3P0C	VBN2BG3S0C	VBN2BG3P0D	VBN2BG3S0D	VBN2BG3P0X	VBN2BG3S0X	
	4.3	VBN2BH3P0C	VBN2BH3S0C	VBN2BH3P0D	VBN2BH3S0D	VBN2BH3P0X	VBN2BH3S0X	
	7.4	VBN2BJ3P0C	VBN2BJ3S0C	VBN2BJ3P0D	VBN2BJ3S0D	VBN2BJ3P0X	VBN2BJ3S0X	
	10.1	VBN2BK3P0C	VBN2BK3S0C	VBN2BK3P0D	VBN2BK3S0D	VBN2BK3P0X	VBN2BK3S0X	
	14.7*	VBN2BL3P0C	VBN2BL3S0C	VBN2BL3P0D	VBN2BL3S0D	VBN2BL3P0X	VBN2BL3S0X	
	29*	VBN2BM3P0C	VBN2BM3S0C	VBN2BM3P0D	VBN2BM3S0D	VBN2BM3P0X	VBN2BM3S0X	
	4.4	VBN2CH3P0C	VBN2CH3S0C	VBN2CH3P0D	VBN2CH3S0D	VBN2CH3P0X	VBN2CH3S0X	
	9	VBN2CJ3P0C	VBN2CJ3S0C	VBN2CJ3P0D	VBN2CJ3S0D	VBN2CJ3P0X	VBN2CJ3S0X	
	15.3	VBN2CL3P0C	VBN2CL3S0C	VBN2CL3P0D	VBN2CL3S0D	VBN2CL3P0X	VBN2CL3S0X	
1"	26	VBN2CM3P0C	VBN2CM3S0C	VBN2CM3P0D	VBN2CM3S0D	VBN2CM3P0X	VBN2CM3S0X	
	44*	VBN2CN3P0C	VBN2CN3S0C	VBN2CN3P0D	VBN2CN3S0D	VBN2CN3P0X	VBN2CN3S0X	
	54*	VBN2CP3P0C	VBN2CP3S0C	VBN2CP3P0D	VBN2CP3S0D	VBN2CP3P0X	VBN2CP3S0X	
	4.4	VBN2DH3P0C	VBN2DH3S0C	VBN2DH3P0D	VBN2DH3S0D	VBN2DH3P0X	VBN2DH3S0X	
	8.3	VBN2DJ3P0C	VBN2DJ3S0C	VBN2DJ3P0D	VBN2DJ3S0D	VBN2DJ3P0X	VBN2DJ3S0X	
	14.9	VBN2DK3P0C	VBN2DK3S0C	VBN2DK3P0D	VBN2DK3S0D	VBN2DK3P0X	VBN2DK3S0X	
	25	VBN2DL3P0C	VBN2DL3S0C	VBN2DL3P0D	VBN2DL3S0D	VBN2DL3P0X	VBN2DL3S0X	
	37	VBN2DM3P0C	VBN2DM3S0C	VBN2DM3P0D	VBN2DM3S0D	VBN2DM3P0X	VBN2DM3S0X	
	41*	VBN2DN3P0C	VBN2DN3S0C	VBN2DN3P0D	VBN2DN3S0D	VBN2DN3P0X	VBN2DN3S0X	
	102*	VBN2DS3P0C	VBN2DS3S0C	VBN2DS3P0D	VBN2DS3S0D	VBN2DS3P0X	VBN2DS3S0X	
1-1/4"	23	VBN2EL3P0C	VBN2EL3S0C	VBN2EL3P0D	VBN2EL3S0D	VBN2EL3P0X	VBN2EL3S0X	
	30	VBN2EM3P0C	VBN2EM3S0C	VBN2EM3P0D	VBN2EM3S0D	VBN2EM3P0X	VBN2EM3S0X	
	41	VBN2EN3P0C	VBN2EN3S0C	VBN2EN3P0D	VBN2EN3S0D	VBN2EN3P0X	VBN2EN3S0X	
	74*	VBN2ER3P0C	VBN2ER3S0C	VBN2ER3P0D	VBN2ER3S0D	VBN2ER3P0X	VBN2ER3S0X	
	172*	VBN2E13P0C	VBN2E13S0C	VBN2E13P0D	VBN2E13S0D	VBN2E13P0X	VBN2E13S0X	
	42	VBN2FN3P0C	VBN2FN3S0C	VBN2FN3P0D	VBN2FN3S0D	VBN2FN3P0X	VBN2FN3S0X	
	57	VBN2FP3P0C	VBN2FP3S0C	VBN2FP3P0D	VBN2FP3S0D	VBN2FP3P0X	VBN2FP3S0X	
	71	VBN2FR3P0C	VBN2FR3S0C	VBN2FR3P0D	VBN2FR3S0D	VBN2FR3P0X	VBN2FR3S0X	
	100	VBN2FS3P0C	VBN2FS3S0C	VBN2FS3P0D	VBN2FS3S0D	VBN2FS3P0X	VBN2FS3S0X	
	108*	VBN2FT3P0C	VBN2FT3S0C	VBN2FT3P0D	VBN2FT3S0D	VBN2FT3P0X	VBN2FT3S0X	
1-1/2"	210	VBN2F13P0C	VBN2F13S0C	VBN2F13P0D	VBN2F13S0D	VBN2F13P0X	VBN2F13S0X	
	266*	VBN2F23P0C	VBN2F23S0C	VBN2F23P0D	VBN2F23S0D	VBN2F23P0X	VBN2F23S0X	
	45	VBN2GN3P0C	VBN2GN3S0C	VBN2GN3P0D	VBN2GN3S0D	VBN2GN3P0X	VBN2GN3S0X	
	55	VBN2GP3P0C	VBN2GP3S0C	VBN2GP3P0D	VBN2GP3S0D	VBN2GP3P0X	VBN2GP3S0X	
	72	VBN2GR3P0C	VBN2GR3S0C	VBN2GR3P0D	VBN2GR3S0D	VBN2GR3P0X	VBN2GR3S0X	
	101	VBN2GS3P0C	VBN2GS3S0C	VBN2GS3P0D	VBN2GS3S0D	VBN2GS3P0X	VBN2GS3S0X	
	162	VBN2GU3P0C	VBN2GU3S0C	VBN2GU3P0D	VBN2GU3S0D	VBN2GU3P0X	VBN2GU3S0X	
	202*	VBN2G13P0C	VBN2G13S0C	VBN2G13P0D	VBN2G13S0D	VBN2G13P0X	VBN2G13S0X	
	49	VBN2HN3P0C	VBN2HN3S0C	VBN2HN3P0D	VBN2HN3S0D	VBN2HN3P0X	VBN2HN3S0X	
	63	VBN2HP3P0C	VBN2HP3S0C	VBN2HP3P0D	VBN2HP3S0D	VBN2HP3P0X	VBN2HP3S0X	
3"	82	VBN2HR3P0C	VBN2HR3S0C	VBN2HR3P0D	VBN2HR3S0D	VBN2HR3P0X	VBN2HR3S0X	
	124	VBN2HT3P0C	VBN2HT3S0C	VBN2HT3P0D	VBN2HT3S0D	VBN2HT3P0X	VBN2HT3S0X	
	145*	VBN2HU3P0C	VBN2HU3S0C	VBN2HU3P0D	VBN2HU3S0D	VBN2HU3P0X	VBN2HU3S0X	

Full port ball. No flow characterizing insert.

Control Ball Valves 1/2- 3"

2-Way NPT NEMA 3R

Common Features

- Max static pressure 360 psi (250°F)
- Medium: Water/glycol solutions up to 50%.
- Temperature range: -22 to +250°F
- Field configurable open or closed fail-safe position
- Removable handle for manual operation
- ANSI class IV leakage (0.01% of Cv)

VBN2 (Two-way):

- Equal % flow insert. Linear with full port.
(Largest Cv valve in each valve size is full port)
- Nickel-chrome plated brass or 316 stainless steel ball and stem

Optional NEMA 3R enclosure



2-Way

Actuator Features		Non-fail Safe			
Actuator O.S. Number		MN6105A1011	MN6105A1011	MN7505A2001	MN7505A2001
Power Supply	Voltage	24 Vac	24 Vac	24 Vac	24 Vac
	Frequency	50 / 60 Hz	50 / 60 Hz	50 / 60 Hz	50 / 60 Hz
	Power	5 VA	5 VA	5 VA	5 VA
Actuator Torque	(lb.-in.)	44	44	44	44
Control	(0)2-10 Vdc			•	•
	4-20 mA (external 500 Ohm Resistor)			•	•
	Floating	•	•	•	•
	Two-Position SPDT	•	•	•	•
	Two-Position SPST			•	•
Fail Safe Action		Stay in Place	Stay in Place	Stay in Place	Stay in Place
Normal Position (no signal)		Closed	Closed	Closed	Closed
Actuator Stroke	(degrees)	95° ± 3°	95° ± 3°	95° ± 3°	95° ± 3°
Timing	(seconds)	90	90	90	90
Aux Switch	2 x SPDT Add-on	SSW2	SSW2	SW2-US	SW2-US
Feedback	2-10 Vdc Built In			•	•
Valve Features	Trim	Nickel-Plated Brass	Stainless Steel	Nickel-Plated Brass	Stainless Steel

Valve Size (inches)	Cv	Close-off Differential Pressure (psi)	Valve O.S. Number			
			1	2	3	4
1/2"	0.38	130	VBN2AB3PRA	VBN2AB3SRA	VBN2AB3PRB	VBN2AB3SRB
	0.68		VBN2AD3PRA	VBN2AD3SRA	VBN2AD3PRB	VBN2AD3SRB
	1.3		VBN2AE3PRA	VBN2AE3SRA	VBN2AE3PRB	VBN2AE3SRB
	2		VBN2AF3PRA	VBN2AF3SRA	VBN2AF3PRB	VBN2AF3SRB
	2.6		VBN2AG3PRA	VBN2AG3SRA	VBN2AG3PRB	VBN2AG3SRB
	4.7		VBN2AH3PRA	VBN2AH3SRA	VBN2AH3PRB	VBN2AH3SRB
	8		VBN2AJ3PRA	VBN2AJ3SRA	VBN2AJ3PRB	VBN2AJ3SRB
	11.7*		VBN2AK3PRA	VBN2AK3SRA	VBN2AK3PRB	VBN2AK3SRB
3/4"	0.31		VBN2BB3PRA	VBN2BB3SRA	VBN2BB3PRB	VBN2BB3SRB
	0.63		VBN2BD3PRA	VBN2BD3SRA	VBN2BD3PRB	VBN2BD3SRB
	1.2		VBN2BE3PRA	VBN2BE3SRA	VBN2BE3PRB	VBN2BE3SRB
	2.5		VBN2BG3PRA	VBN2BG3SRA	VBN2BG3PRB	VBN2BG3SRB
	4.3		VBN2BH3PRA	VBN2BH3SRA	VBN2BH3PRB	VBN2BH3SRB
	7.4		VBN2BJ3PRA	VBN2BJ3SRA	VBN2BJ3PRB	VBN2BJ3SRB
	10.1		VBN2BK3PRA	VBN2BK3SRA	VBN2BK3PRB	VBN2BK3SRB
	14.7*		VBN2BL3PRA	VBN2BL3SRA	VBN2BL3PRB	VBN2BL3SRB
1"	29*	VBN2BM3PRA	VBN2BM3SRA	VBN2BM3PRB	VBN2BM3SRB	
	4.4	VBN2CH3PRA	VBN2CH3SRA	VBN2CH3PRB	VBN2CH3SRB	
	9	VBN2CJ3PRA	VBN2CJ3SRA	VBN2CJ3PRB	VBN2CJ3SRB	
	15.3	VBN2CL3PRA	VBN2CL3SRA	VBN2CL3PRB	VBN2CL3SRB	
	26	VBN2CM3PRA	VBN2CM3SRA	VBN2CM3PRB	VBN2CM3SRB	
	44*	VBN2CN3PRA	VBN2CN3SRA	VBN2CN3PRB	VBN2CN3SRB	
	54*	VBN2CP3PRA	VBN2CP3SRA	VBN2CP3PRB	VBN2CP3SRB	
	1-1/4"	4.4	VBN2DH3PRA	VBN2DH3SRA	VBN2DH3PRB	VBN2DH3SRB
8.3		VBN2DJ3PRA	VBN2DJ3SRA	VBN2DJ3PRB	VBN2DJ3SRB	
14.9		VBN2DK3PRA	VBN2DK3SRA	VBN2DK3PRB	VBN2DK3SRB	
25		VBN2DL3PRA	VBN2DL3SRA	VBN2DL3PRB	VBN2DL3SRB	
37		VBN2DM3PRA	VBN2DM3SRA	VBN2DM3PRB	VBN2DM3SRB	
41*		VBN2DN3PRA	VBN2DN3SRA	VBN2DN3PRB	VBN2DN3SRB	
102*		VBN2DS3PRA	VBN2DS3SRA	VBN2DS3PRB	VBN2DS3SRB	
1-1/2"		23	VBN2EL3PRA	VBN2EL3SRA	VBN2EL3PRB	VBN2EL3SRB
	30	VBN2EM3PRA	VBN2EM3SRA	VBN2EM3PRB	VBN2EM3SRB	
	41	VBN2EN3PRA	VBN2EN3SRA	VBN2EN3PRB	VBN2EN3SRB	
	74*	VBN2ER3PRA	VBN2ER3SRA	VBN2ER3PRB	VBN2ER3SRB	
	172*	VBN2E13PRA	VBN2E13SRA	VBN2E13PRB	VBN2E13SRB	
	2"	42	VBN2FN3PRA	VBN2FN3SRA	VBN2FN3PRB	VBN2FN3SRB
		57	VBN2FP3PRA	VBN2FP3SRA	VBN2FP3PRB	VBN2FP3SRB
		71	VBN2FR3PRA	VBN2FR3SRA	VBN2FR3PRB	VBN2FR3SRB
100		VBN2FS3PRA	VBN2FS3SRA	VBN2FS3PRB	VBN2FS3SRB	
108*		VBN2FT3PRA	VBN2FT3SRA	VBN2FT3PRB	VBN2FT3SRB	
210		VBN2F13PRA	VBN2F13SRA	VBN2F13PRB	VBN2F13SRB	
266*		VBN2F23PRA	VBN2F23SRA	VBN2F23PRB	VBN2F23SRB	
2-1/2"		45	VBN2GN3PRA	VBN2GN3SRA	VBN2GN3PRB	VBN2GN3SRB
	55	VBN2GP3PRA	VBN2GP3SRA	VBN2GP3PRB	VBN2GP3SRB	
	72	VBN2GR3PRA	VBN2GR3SRA	VBN2GR3PRB	VBN2GR3SRB	
	101	VBN2GS3PRA	VBN2GS3SRA	VBN2GS3PRB	VBN2GS3SRB	
	162	VBN2GU3PRA	VBN2GU3SRA	VBN2GU3PRB	VBN2GU3SRB	
	202*	VBN2G13PRA	VBN2G13SRA	VBN2G13PRB	VBN2G13SRB	
	3"	49	VBN2HN3PRA	VBN2HN3SRA	VBN2HN3PRB	VBN2HN3SRB
		63	VBN2HP3PRA	VBN2HP3SRA	VBN2HP3PRB	VBN2HP3SRB
82		VBN2HR3PRA	VBN2HR3SRA	VBN2HR3PRB	VBN2HR3SRB	
124		VBN2HT3PRA	VBN2HT3SRA	VBN2HT3PRB	VBN2HT3SRB	
145*		VBN2HU3PRA	VBN2HU3SRA	VBN2HU3PRB	VBN2HU3SRB	

Full port ball. No flow characterizing insert.

Control Ball Valves 1/2- 3"

2-Way NPT NEMA 3R

Actuator Features		Fail Safe					
Actuator O.S. Number		MS8105A1030	MS8105A1030	MS7505A2030	MS7505A2030	Valve Only	Valve Only
Power Supply	Voltage	24 Vac	24 Vac	24 Vac	24 Vac		
	Frequency	50 / 60 Hz	50 / 60 Hz	50 / 60 Hz	50 / 60 Hz		
	Power	8VA	8VA	7.5 VA	7.5 VA		
Actuator Torque	(lb.-in.)	44	44	44	44		
Control	(0)2-10 Vdc			•	•		
	4-20 mA (external 500 Ohm Resistor)			•	•		
	Floating			•	•		
	Two-Position SPDT			•	•		
	Two-Position SPST	•	•	•	•		
Fail Safe Action		Closed*	Closed*	Closed*	Closed*		
Normal Position (no signal)		Closed	Closed	Closed	Closed		
Actuator Stroke	(degrees)	95° ± 3°	95° ± 3°	95° ± 3°	95° ± 3°		
Timing	(seconds)	45	45	90	90		
Aux Switch	2 x SPDT Add-on						
Feedback	2-10 Vdc Built In			•	•		
Valve Features	Trim	Nickel-Plated Brass	Stainless Steel	Nickel-Plated Brass	Stainless Steel	Nickel-Plated Brass	Stainless Steel

Valve Size (inches)	Cv	Close-off Differential Pressure (psi)	Valve O.S. Number					
			1	2	3	4		
1/2"	0.38	130	VBN2AB3PRC	VBN2AB3SRC	VBN2AB3PRD	VBN2AB3SRD	—	—
	0.68		VBN2AD3PRC	VBN2AD3SRC	VBN2AD3PRD	VBN2AD3SRD	—	—
	1.3		VBN2AE3PRC	VBN2AE3SRC	VBN2AE3PRD	VBN2AE3SRD	—	—
	2		VBN2AF3PRC	VBN2AF3SRC	VBN2AF3PRD	VBN2AF3SRD	—	—
	2.6		VBN2AG3PRC	VBN2AG3SRC	VBN2AG3PRD	VBN2AG3SRD	—	—
	4.7		VBN2AH3PRC	VBN2AH3SRC	VBN2AH3PRD	VBN2AH3SRD	—	—
	8		VBN2AJ3PRC	VBN2AJ3SRC	VBN2AJ3PRD	VBN2AJ3SRD	—	—
	11.7*		VBN2AK3PRC	VBN2AK3SRC	VBN2AK3PRD	VBN2AK3SRD	—	—
	0.31		VBN2BB3PRC	VBN2BB3SRC	VBN2BB3PRD	VBN2BB3SRD	—	—
	0.63		VBN2BD3PRC	VBN2BD3SRC	VBN2BD3PRD	VBN2BD3SRD	—	—
	1.2		VBN2BE3PRC	VBN2BE3SRC	VBN2BE3PRD	VBN2BE3SRD	—	—
	2.5		VBN2BG3PRC	VBN2BG3SRC	VBN2BG3PRD	VBN2BG3SRD	—	—
	4.3		VBN2BH3PRC	VBN2BH3SRC	VBN2BH3PRD	VBN2BH3SRD	—	—
	7.4		VBN2BJ3PRC	VBN2BJ3SRC	VBN2BJ3PRD	VBN2BJ3SRD	—	—
10.1	VBN2BK3PRC	VBN2BK3SRC	VBN2BK3PRD	VBN2BK3SRD	—	—		
14.7*	VBN2BL3PRC	VBN2BL3SRC	VBN2BL3PRD	VBN2BL3SRD	—	—		
29*	VBN2BM3PRC	VBN2BM3SRC	VBN2BM3PRD	VBN2BM3SRD	—	—		
1"	4.4	100	VBN2CH3PRC	VBN2CH3SRC	VBN2CH3PRD	VBN2CH3SRD	—	—
	9		VBN2CJ3PRC	VBN2CJ3SRC	VBN2CJ3PRD	VBN2CJ3SRD	—	—
	15.3		VBN2CL3PRC	VBN2CL3SRC	VBN2CL3PRD	VBN2CL3SRD	—	—
	26		VBN2CM3PRC	VBN2CM3SRC	VBN2CM3PRD	VBN2CM3SRD	—	—
	44*		VBN2CN3PRC	VBN2CN3SRC	VBN2CN3PRD	VBN2CN3SRD	—	—
	54*		VBN2CP3PRC	VBN2CP3SRC	VBN2CP3PRD	VBN2CP3SRD	—	—
	4.4		VBN2DH3PRC	VBN2DH3SRC	VBN2DH3PRD	VBN2DH3SRD	—	—
1-1/4"	8.3	100	VBN2DJ3PRC	VBN2DJ3SRC	VBN2DJ3PRD	VBN2DJ3SRD	—	—
	14.9		VBN2DK3PRC	VBN2DK3SRC	VBN2DK3PRD	VBN2DK3SRD	—	—
	25		VBN2DL3PRC	VBN2DL3SRC	VBN2DL3PRD	VBN2DL3SRD	—	—
	37		VBN2DM3PRC	VBN2DM3SRC	VBN2DM3PRD	VBN2DM3SRD	—	—
	41*		VBN2DN3PRC	VBN2DN3SRC	VBN2DN3PRD	VBN2DN3SRD	—	—
	102*		VBN2DS3PRC	VBN2DS3SRC	VBN2DS3PRD	VBN2DS3SRD	—	—
	23		VBN2EL3PRC	VBN2EL3SRC	VBN2EL3PRD	VBN2EL3SRD	—	—
1-1/2"	30	100	VBN2EM3PRC	VBN2EM3SRC	VBN2EM3PRD	VBN2EM3SRD	—	—
	41		VBN2EN3PRC	VBN2EN3SRC	VBN2EN3PRD	VBN2EN3SRD	—	—
	74*		VBN2ER3PRC	VBN2ER3SRC	VBN2ER3PRD	VBN2ER3SRD	—	—
	172*		VBN2E13PRC	VBN2E13SRC	VBN2E13PRD	VBN2E13SRD	—	—
	42		VBN2FN3PRC	VBN2FN3SRC	VBN2FN3PRD	VBN2FN3SRD	—	—
2"	57	100	VBN2FP3PRC	VBN2FP3SRC	VBN2FP3PRD	VBN2FP3SRD	—	—
	71		VBN2FR3PRC	VBN2FR3SRC	VBN2FR3PRD	VBN2FR3SRD	—	—
	100		VBN2FS3PRC	VBN2FS3SRC	VBN2FS3PRD	VBN2FS3SRD	—	—
	108*		VBN2FT3PRC	VBN2FT3SRC	VBN2FT3PRD	VBN2FT3SRD	—	—
	210		VBN2F13PRC	VBN2F13SRC	VBN2F13PRD	VBN2F13SRD	—	—
	266*		VBN2F23PRC	VBN2F23SRC	VBN2F23PRD	VBN2F23SRD	—	—
	45		VBN2GN3PRC	VBN2GN3SRC	VBN2GN3PRD	VBN2GN3SRD	—	—
2-1/2"	55	100	VBN2GP3PRC	VBN2GP3SRC	VBN2GP3PRD	VBN2GP3SRD	—	—
	72		VBN2GR3PRC	VBN2GR3SRC	VBN2GR3PRD	VBN2GR3SRD	—	—
	101		VBN2GS3PRC	VBN2GS3SRC	VBN2GS3PRD	VBN2GS3SRD	—	—
	162		VBN2GU3PRC	VBN2GU3SRC	VBN2GU3PRD	VBN2GU3SRD	—	—
	202*		VBN2G13PRC	VBN2G13SRC	VBN2G13PRD	VBN2G13SRD	—	—
3"	49	100	VBN2HN3PRC	VBN2HN3SRC	VBN2HN3PRD	VBN2HN3SRD	—	—
	63		VBN2HP3PRC	VBN2HP3SRC	VBN2HP3PRD	VBN2HP3SRD	—	—
	82		VBN2HR3PRC	VBN2HR3SRC	VBN2HR3PRD	VBN2HR3SRD	—	—
	124		VBN2HT3PRC	VBN2HT3SRC	VBN2HT3PRD	VBN2HT3SRD	—	—
	145*		VBN2HU3PRC	VBN2HU3SRC	VBN2HU3PRD	VBN2HU3SRD	—	—

Full port ball. No flow characterizing insert.

Control Ball Valves 1/2- 2 1/2"

3-Way NPT NEMA 2

Common Features

VB3 (Three-way):

- Equal % A to AB, linear B to AB
- Nickel-chrome plated brass ball and stem
- Convert to 2-way by plugging B port (plug not provided)
- Mixing or diverting control with the same valve

Actuator Features		Non-fail Safe		Fail Safe		Valve Only
Actuator O.S. Number		MN6105A1011	MN7505A2001	MS8105A1030	MS7505A2030	
Power Supply	Voltage	24 Vac	24 Vac	24 Vac	24 Vac	
	Frequency	50 / 60 Hz	50 / 60 Hz	50 / 60 Hz	50 / 60 Hz	
Actuator Torque	Power	5 VA	5 VA	8 VA	7.5 VA	
	(lb.-in.)	44	44	44	44	
Control	(0)2-10 Vdc		•		•	
	4-20 mA (external 500 Ohm Resistor)		•		•	
Fail Safe Action	Floating	•	•		•	
	Two-Position SPDT	•	•		•	
Normal Position (no signal)	Two-Position SPST		•	•	•	
	(field configurable)	Stay in Place	Stay in Place	A-AB Closed	A-AB Closed	
Actuator Stroke	(field configurable)	Closed	Closed	A-AB Closed	A-AB Closed	
	(degrees)	95° ± 3°	95° ± 3°	95° ± 3°	95° ± 3°	
Timing	(seconds)	90	90	45	90	
	Aux Switch	2 x SPDT Add-on	SSW2			
Feedback	2-10 Vdc Built In		•		•	
Valve Features	Trim	Nickel-Plated Brass	Nickel-Plated Brass	Nickel-Plated Brass	Nickel-Plated Brass	Nickel-Plated Brass



Valve Size (inches)	Cv	Close-off Differential Pressure (psi)	Valve O.S. Number				
			1/2"	0.33	50	VB3AB3POA	VB3AB3POB
	0.59	VB3AC3POA	VB3AC3POB	VB3AC3POC		VB3AC3POD	VB3AC3POX
	1	VB3AE3POA	VB3AE3POB	VB3AE3POC		VB3AE3POD	VB3AE3POX
	2.4	VB3AF3POA	VB3AF3POB	VB3AF3POC		VB3AF3POD	VB3AF3POX
	4.3	VB3AH3POA	VB3AH3POB	VB3AH3POC		VB3AH3POD	VB3AH3POX
	8*	VB3AJ3POA	VB3AJ3POB	VB3AJ3POC		VB3AJ3POD	VB3AJ3POX
3/4"	0.4	VB3BC3POA	VB3BC3POB	VB3BC3POC		VB3BC3POD	VB3BC3POX
	0.66	VB3BD3POA	VB3BD3POB	VB3BD3POC		VB3BD3POD	VB3BD3POX
	1.3	VB3BE3POA	VB3BE3POB	VB3BE3POC		VB3BE3POD	VB3BE3POX
	2.4	VB3BF3POA	VB3BF3POB	VB3BF3POC		VB3BF3POD	VB3BF3POX
	3.8	VB3BG3POA	VB3BG3POB	VB3BG3POC		VB3BG3POD	VB3BG3POX
	7	VB3BJ3POA	VB3BJ3POB	VB3BJ3POC		VB3BJ3POD	VB3BJ3POX
1"	11*	VB3BK3POA	VB3BK3POB	VB3BK3POC		VB3BK3POD	VB3BK3POX
	0.4	VB3CC3POA	VB3CC3POB	VB3CC3POC	VB3CC3POD	VB3CC3POX	
	0.65	VB3CD3POA	VB3CD3POB	VB3CD3POC	VB3CD3POD	VB3CD3POX	
	1.3	VB3CE3POA	VB3CE3POB	VB3CE3POC	VB3CE3POD	VB3CE3POX	
	2.3	VB3CF3POA	VB3CF3POB	VB3CF3POC	VB3CF3POD	VB3CF3POX	
	3.5	VB3CG3POA	VB3CG3POB	VB3CG3POC	VB3CG3POD	VB3CG3POX	
	4.5	VB3CH3POA	VB3CH3POB	VB3CH3POC	VB3CH3POD	VB3CH3POX	
	8.6	VB3CJ3POA	VB3CJ3POB	VB3CJ3POC	VB3CJ3POD	VB3CJ3POX	
	14.9	VB3CK3POA	VB3CK3POB	VB3CK3POC	VB3CK3POD	VB3CK3POX	
	22*	VB3CL3POA	VB3CL3POB	VB3CL3POC	VB3CL3POD	VB3CL3POX	
	31*	VB3CM3POA	VB3CM3POB	VB3CM3POC	VB3CM3POD	VB3CM3POX	
1-1/4"	4.1	VB3DH3POA	VB3DH3POB	VB3DH3POC	VB3DH3POD	VB3DH3POX	
	8.7	VB3DJ3POA	VB3DJ3POB	VB3DJ3POC	VB3DJ3POD	VB3DJ3POX	
	12.7	VB3DK3POA	VB3DK3POB	VB3DK3POC	VB3DK3POD	VB3DK3POX	
	19.4*	VB3DL3POA	VB3DL3POB	VB3DL3POC	VB3DL3POD	VB3DL3POX	
	27	VB3DM3POA	VB3DM3POB	VB3DM3POC	VB3DM3POD	VB3DM3POX	
	34*	VB3DN3POA	VB3DN3POB	VB3DN3POC	VB3DN3POD	VB3DN3POX	
	4	VB3EH3POA	VB3EH3POB	VB3EH3POC	VB3EH3POD	VB3EH3POX	
1-1/2"	8.3	VB3EJ3POA	VB3EJ3POB	VB3EJ3POC	VB3EJ3POD	VB3EJ3POX	
	13.4	VB3EK3POA	VB3EK3POB	VB3EK3POC	VB3EK3POD	VB3EK3POX	
	24	VB3EL3POA	VB3EL3POB	VB3EL3POC	VB3EL3POD	VB3EL3POX	
	32*	VB3EM3POA	VB3EM3POB	VB3EM3POC	VB3EM3POD	VB3EM3POX	
	61*	VB3EP3POA	VB3EP3POB	VB3EP3POC	VB3EP3POD	VB3EP3POX	
	24	VB3FL3POA	VB3FL3POB	VB3FL3POC	VB3FL3POD	VB3FL3POX	
	38	VB3FN3POA	VB3FN3POB	VB3FN3POC	VB3FN3POD	VB3FN3POX	
2"	57*	VB3FP3POA	VB3FP3POB	VB3FP3POC	VB3FP3POD	VB3FP3POX	
	83	VB3FR3POA	VB3FR3POB	VB3FR3POC	VB3FR3POD	VB3FR3POX	
	109*	VB3FT3POA	VB3FT3POB	VB3FT3POC	VB3FT3POD	VB3FT3POX	
	38	VB3GN3POA	VB3GN3POB	VB3GN3POC	VB3GN3POD	VB3GN3POX	
	74	VB3GR3POA	VB3GR3POB	VB3GR3POC	VB3GR3POD	VB3GR3POX	
2-1/2"	100*	VB3GS3POA	VB3GS3POB	VB3GS3POC	VB3GS3POD	VB3GS3POX	

* Full port ball. No flow characterizing insert.



3-Way

NEED TO PHOTOSHOP



Control Ball Valves 1/2-2 1/2"

3-Way NPT NEMA 3R

Actuator Features		Non-fail Safe		Fail Safe		Valve Only
Actuator O.S. Number		MN6105A1011	MN7505A2001	MS8105A1030	MS7505A2030	
Power Supply	Voltage	24 Vac	24 Vac	24 Vac	24 Vac	
	Frequency	50 / 60 Hz	50 / 60 Hz	50 / 60 Hz	50 / 60 Hz	
	Power	5 VA	5 VA	8 VA	7.5 VA	
Actuator Torque	(lb.-in.)	44	44	44	44	
Control	(0)2-10 Vdc		•		•	
	4-20 mA (external 500 Ohm Resistor)		•		•	
	Floating	•	•		•	
	Two-Position SPDT	•	•		•	
	Two-Position SPST		•	•	•	
Fail Safe Action	(field configurable)	Stay in Place	Stay in Place	A-AB Closed	A-AB Closed	
Normal Position (no signal)	(field configurable)	Closed	Closed	A-AB Closed	A-AB Closed	
Actuator Stroke	(degrees)	95° ± 3°	95° ± 3°	95° ± 3°	95° ± 3°	
Timing	(seconds)	90	90	45	90	
Aux Switch	2 x SPDT Add-on	SSW2	SSW2			
Feedback	2-10 Vdc Built In		•		•	
Valve Features		Trim	Nickel-Plated Brass	Nickel-Plated Brass	Nickel-Plated Brass	Nickel-Plated Brass

Valve Size (inches)	Cv	Close-off Differential Pressure (psi)	Valve O.S. Number				
			1	2	3	4	
1/2"	0.33	50	VBN3AB3PRA	VBN3AB3PRB	VBN3AB3PRC	VBN3AB3PRD	—
	0.59		VBN3AC3PRA	VBN3AC3PRB	VBN3AC3PRC	VBN3AC3PRD	—
	1		VBN3AE3PRA	VBN3AE3PRB	VBN3AE3PRC	VBN3AE3PRD	—
	2.4		VBN3AF3PRA	VBN3AF3PRB	VBN3AF3PRC	VBN3AF3PRD	—
	4.3		VBN3AH3PRA	VBN3AH3PRB	VBN3AH3PRC	VBN3AH3PRD	—
	8*		VBN3AJ3PRA	VBN3AJ3PRB	VBN3AJ3PRC	VBN3AJ3PRD	—
3/4"	0.4		VBN3BC3PRA	VBN3BC3PRB	VBN3BC3PRC	VBN3BC3PRD	—
	0.66		VBN3BD3PRA	VBN3BD3PRB	VBN3BD3PRC	VBN3BD3PRD	—
	1.3		VBN3BE3PRA	VBN3BE3PRB	VBN3BE3PRC	VBN3BE3PRD	—
	2.4		VBN3BF3PRA	VBN3BF3PRB	VBN3BF3PRC	VBN3BF3PRD	—
	3.8		VBN3BG3PRA	VBN3BG3PRB	VBN3BG3PRC	VBN3BG3PRD	—
	7		VBN3BJ3PRA	VBN3BJ3PRB	VBN3BJ3PRC	VBN3BJ3PRD	—
	11*		VBN3BK3PRA	VBN3BK3PRB	VBN3BK3PRC	VBN3BK3PRD	—
1"	0.4		VBN3CC3PRA	VBN3CC3PRB	VBN3CC3PRC	VBN3CC3PRD	—
	0.65		VBN3CD3PRA	VBN3CD3PRB	VBN3CD3PRC	VBN3CD3PRD	—
	1.3		VBN3CE3PRA	VBN3CE3PRB	VBN3CE3PRC	VBN3CE3PRD	—
	2.3		VBN3CF3PRA	VBN3CF3PRB	VBN3CF3PRC	VBN3CF3PRD	—
	3.5		VBN3CG3PRA	VBN3CG3PRB	VBN3CG3PRC	VBN3CG3PRD	—
	4.5	VBN3CH3PRA	VBN3CH3PRB	VBN3CH3PRC	VBN3CH3PRD	—	
	8.6	VBN3CJ3PRA	VBN3CJ3PRB	VBN3CJ3PRC	VBN3CJ3PRD	—	
	14.9	VBN3CK3PRA	VBN3CK3PRB	VBN3CK3PRC	VBN3CK3PRD	—	
	22*	VBN3CL3PRA	VBN3CL3PRB	VBN3CL3PRC	VBN3CL3PRD	—	
	31*	VBN3CM3PRA	VBN3CM3PRB	VBN3CM3PRC	VBN3CM3PRD	—	
1-1/4"	4.1	VBN3DH3PRA	VBN3DH3PRB	VBN3DH3PRC	VBN3DH3PRD	—	
	8.7	VBN3DJ3PRA	VBN3DJ3PRB	VBN3DJ3PRC	VBN3DJ3PRD	—	
	12.7	VBN3DK3PRA	VBN3DK3PRB	VBN3DK3PRC	VBN3DK3PRD	—	
	19.4*	VBN3DL3PRA	VBN3DL3PRB	VBN3DL3PRC	VBN3DL3PRD	—	
	27	VBN3DM3PRA	VBN3DM3PRB	VBN3DM3PRC	VBN3DM3PRD	—	
	34*	VBN3DN3PRA	VBN3DN3PRB	VBN3DN3PRC	VBN3DN3PRD	—	
1-1/2"	4	VBN3EH3PRA	VBN3EH3PRB	VBN3EH3PRC	VBN3EH3PRD	—	
	8.3	VBN3EJ3PRA	VBN3EJ3PRB	VBN3EJ3PRC	VBN3EJ3PRD	—	
	13.4	VBN3EK3PRA	VBN3EK3PRB	VBN3EK3PRC	VBN3EK3PRD	—	
	24	VBN3EL3PRA	VBN3EL3PRB	VBN3EL3PRC	VBN3EL3PRD	—	
	32*	VBN3EM3PRA	VBN3EM3PRB	VBN3EM3PRC	VBN3EM3PRD	—	
	61*	VBN3EP3PRA	VBN3EP3PRB	VBN3EP3PRC	VBN3EP3PRD	—	
2"	24	VBN3FL3PRA	VBN3FL3PRB	VBN3FL3PRC	VBN3FL3PRD	—	
	38	VBN3FN3PRA	VBN3FN3PRB	VBN3FN3PRC	VBN3FN3PRD	—	
	57*	VBN3FP3PRA	VBN3FP3PRB	VBN3FP3PRC	VBN3FP3PRD	—	
	83	VBN3FR3PRA	VBN3FR3PRB	VBN3FR3PRC	VBN3FR3PRD	—	
	109*	VBN3FT3PRA	VBN3FT3PRB	VBN3FT3PRC	VBN3FT3PRD	—	
2-1/2"	38	VBN3GN3PRA	VBN3GN3PRB	VBN3GN3PRC	VBN3GN3PRD	—	
	74	VBN3GR3PRA	VBN3GR3PRB	VBN3GR3PRC	VBN3GR3PRD	—	
	100*	VBN3GS3PRA	VBN3GS3PRB	VBN3GS3PRC	VBN3GS3PRD	—	



3-Way

Full port ball. No flow characterizing insert.

Flanged Control Ball Valves 4" - 6"

2-Way Flanged NEMA 2+3R

Common Features

- Maximum static pressure 240 psi (-22°F to 250°F)
- Medium: Water/glycol solutions up to 50%
- ANSI class 125 flanged connections
- ANSI class IV leakage (0.01% of Cv)
- Valve ball and stem 316 stainless steel
- Equal percentage flow (linear full port)

Actuator Features		Non-fail Safe		Fail Safe		Valve Only
Actuator O.S. Number		MN6110A1003 4 to 5 in.	MN7510A2001 4 to 5 in.	MS8110A1008 4 to 5 in.	MS7510A2008 4 to 5 in.	Valve Only
		MN6134A1003 6 in.	MN7234A2008 6 in.	MS8120A1007 6 in.	MS7520A2007 6 in.	
Power Supply	Voltage	24 Vac	24 Vac	24 Vac	24 Vac	
	Frequency	50 / 60 Hz	50 / 60 Hz	50 / 60 Hz	50 / 60 Hz	
	Power	5 / 9 VA	5 / 9 VA	30 / 40 VA	14 / 16 VA	
Actuator Torque	(lb.-in.)	88/300	88/300	88/175	88/175	
Control	(0)2-10 Vdc		•		•	
	4-20 mA (external 500 Ohm Resistor)		•		•	
	Floating	•	•		•	
	Two-Position SPDT	•	•		•	
	Two-Position SPST	•	•	•	•	
Fail Safe Action	(field configurable)	Stay in Place	Stay in Place	A-AB Closed	A-AB Closed	
Normal Position (no signal)	(field configurable)	Closed	Closed	Closed	Closed	
Actuator Stroke	(degrees)	95°	95°	95°	95°	
Timing	(seconds)	90	90	90	90	
Aux Switch	2 x SPDT Add-on	SW2-US	SW2-US	SW2-US	SW2-US	
Feedback	2-10 Vdc Built In		•		•	
Valve Features	Trim	Stainless Steel	Stainless Steel	Stainless Steel	Stainless Steel	Stainless Steel

Valve Size (inches)	Cv	Close-off Differential Pressure (psi)	Valve O.S. Number				
NEMA 2 Actuator							
4"	91	70	VBF2JC1S0A	VBF2JC1S0B	VBF2JC1S0C	VBF2JC1S0D	VBF2JC1S0X
	118		VBF2JT1S0A	VBF2JT1S0B	VBF2JT1S0C	VBF2JT1S0D	VBF2JT1S0X
	152		VBF2JU1S0A	VBF2JU1S0B	VBF2JU1S0C	VBF2JU1S0D	VBF2JU1S0X
	197		VBF2J11S0A	VBF2J11S0B	VBF2J11S0C	VBF2J11S0D	VBF2J11S0X
	254		VBF2J21S0A	VBF2J21S0B	VBF2J21S0C	VBF2J21S0D	VBF2J21S0X
5"	144		VBF2KU1S0A	VBF2KU1S0B	VBF2KU1S0C	VBF2KU1S0D	VBF2KU1S0X
	185		VBF2K11S0A	VBF2K11S0B	VBF2K11S0C	VBF2K11S0D	VBF2K11S0X
	240		VBF2K21S0A	VBF2K21S0B	VBF2K21S0C	VBF2K21S0D	VBF2K21S0X
	309		VBF2K31S0A	VBF2K31S0B	VBF2K31S0C	VBF2K31S0D	VBF2K31S0X
	400		VBF2K41S0A	VBF2K41S0B	VBF2K41S0C	—	VBF2K41S0X
6"	208		VBF2L11S0A	VBF2L11S0B	VBF2L11S0C	VBF2L11S0D	VBF2L11S0X
	268		VBF2L21S0A	VBF2L21S0B	VBF2L21S0C	VBF2L21S0D	VBF2L21S0X
	346		VBF2L41S0A	VBF2L41S0B	VBF2L41S0C	—	VBF2L41S0X
	441		VBF2L51S0A	VBF2L51S0B	VBF2L51S0C	—	VBF2L51S0X
	577		VBF2L61S0A	VBF2L61S0B	VBF2L61S0C	—	VBF2L61S0X
650	VBF2L71S0A	VBF2L71S0B	VBF2L71S0C	—	VBF2L71S0X		
NEMA 3R Actuator							
4"	91	70	VBF2JC1SRA	VBF2JC1SRB	VBF2JC1SRC	VBF2JC1SRD	—
	118		VBF2JT1SRA	VBF2JT1SRB	VBF2JT1SRC	VBF2JT1SRD	—
	152		VBF2JU1SRA	VBF2JU1SRB	VBF2JU1SRC	VBF2JU1SRD	—
	197		VBF2J11SRA	VBF2J11SRB	VBF2J11SRC	VBF2J11SRD	—
	254		VBF2J21SRA	VBF2J21SRB	VBF2J21SRC	VBF2J21SRD	—
5"	144		VBF2KU1SRA	VBF2KU1SRB	VBF2KU1SRC	VBF2KU1SRD	—
	185		VBF2K11SRA	VBF2K11SRB	VBF2K11SRC	VBF2K11SRD	—
	240		VBF2K21SRA	VBF2K21SRB	VBF2K21SRC	VBF2K21SRD	—
	309		VBF2K31SRA	VBF2K31SRB	VBF2K31SRC	VBF2K31SRD	—
	400		VBF2K41SRA	VBF2K41SRB	VBF2K41SRC	—	—
6"	208		VBF2L11SRA	VBF2L11SRB	VBF2L11SRC	VBF2L11SRD	—
	268		VBF2L21SRA	VBF2L21SRB	VBF2L21SRC	VBF2L21SRD	—
	346		VBF2L41SRA	VBF2L41SRB	VBF2L41SRC	—	—
	441		VBF2L51SRA	VBF2L51SRB	VBF2L51SRC	—	—
	577		VBF2L61SRA	VBF2L61SRB	VBF2L61SRC	—	—
650	VBF2L71SRA	VBF2L71SRB	VBF2L71SRC	—	—		



2-Way

NEW PHOTO



Flanged Control Ball Valves 4"- 6"

3-Way Flanged NEMA 2+3R

Common Features

- Mixing or diverting with the same 3-way valve
- Globe valve A-B-AB flow pattern (side B port)
- Three-way: A-AB equal percentage, B-AB linear (80% of Cv on B-port)

Actuator Features		Non-fail Safe		Fail Safe		Valve Only
Actuator O.S. Number		MN6110A1003 4 to 5 in.	MN7510A2001 4 to 5 in.	MS8110A1008 4 to 5 in.	MS7510A2008 4 to 5 in.	Valve Only
		MN6134A1003 6 in.	MN7234A2008 6 in.	MS8120A1007 6 in.	MS7520A2007 6 in.	
Power Supply	Voltage	24 Vac	24 Vac	24 Vac	24 Vac	
	Frequency	50 / 60 Hz	50 / 60 Hz	50 / 60 Hz	50 / 60 Hz	
	Power	5 / 9 VA	5 / 9 VA	30 / 40 VA	14 / 16 VA	
Actuator Torque	(lb.-in.)	88/300	88/300	88/175	88/175	
Control	(0)2-10 Vdc		•		•	
	4-20 mA (external 500 Ohm Resistor)		•		•	
	Floating	•	•		•	
	Two-Position SPDT	•	•		•	
	Two-Position SPST	•	•	•	•	
Fail Safe Action	(field configurable)	Stay in Place	Stay in Place	A-AB Closed	A-AB Closed	
Normal Position (no signal)	(field configurable)	A-AB Closed	A-AB Closed	A-AB Closed	A-AB Closed	
Actuator Stroke	(degrees)	95°	95°	95°	95°	
Timing	(seconds)	90	90	90	90	
Aux Switch	2 x SPDT Add-on	SW2-US	SW2-US	SW2-US	SW2-US	
Feedback	2-10 Vdc Built In		•		•	
Valve Features	Trim	Stainless Steel	Stainless Steel	Stainless Steel	Stainless Steel	Stainless Steel

Valve Size (inches)	Cv	Close-off Differential Pressure (psi)	Valve O.S. Number				
NEMA 2 Actuator							
4"	91	70	VBF3JS1S0A	VBF3JS1S0B	VBF3JS1S0C	VBF3JS1S0D	VBF3JS1S0X
	118		VBF3JT1S0A	VBF3JT1S0B	VBF3JT1S0C	VBF3JT1S0D	VBF3JT1S0X
	152		VBF3JU1S0A	VBF3JU1S0B	VBF3JU1S0C	VBF3JU1S0D	VBF3JU1S0X
	197		VBF3J11S0A	VBF3J11S0B	VBF3J11S0C	VBF3J11S0D	VBF3J11S0X
	254		VBF3J21S0A	VBF3J21S0B	VBF3J21S0C	VBF3J21S0D	VBF3J21S0X
	327		VBF3J31S0A	VBF3J31S0B	VBF3J31S0C	VBF3J31S0D	VBF3J31S0X
5"	144		VBF3KU1S0A	VBF3KU1S0B	VBF3KU1S0C	VBF3KU1S0D	VBF3KU1S0X
	185		VBF3K11S0A	VBF3K11S0B	VBF3K11S0C	VBF3K11S0D	VBF3K11S0X
	240		VBF3K21S0A	VBF3K21S0B	VBF3K21S0C	VBF3K21S0D	VBF3K21S0X
	309		VBF3K31S0A	VBF3K31S0B	VBF3K31S0C	VBF3K31S0D	VBF3K31S0X
	400		VBF3K41S0A	VBF3K41S0B	VBF3K41S0C	—	VBF3K41S0X
6"	208		VBF3L11S0A	VBF3L11S0B	VBF3L11S0C	VBF3L11S0D	VBF3L11S0X
	268		VBF3L21S0A	VBF3L21S0B	VBF3L21S0C	VBF3L21S0D	VBF3L21S0X
	346		VBF3L41S0A	VBF3L41S0B	VBF3L41S0C	—	VBF3L41S0X
	441		VBF3L51S0A	VBF3L51S0B	VBF3L51S0C	—	VBF3L51S0X
	577		VBF3L61S0A	VBF3L61S0B	VBF3L61S0C	—	VBF3L61S0X
	650		VBF3L71S0A	VBF3L71S0B	VBF3L71S0C	—	VBF3L71S0X
NEMA 3R Actuator							
4"	91	70	VBF3JS1SRA	VBF3JS1SRB	VBF3JS1SRC	VBF3JS1SRD	—
	118		VBF3JT1SRA	VBF3JT1SRB	VBF3JT1SRC	VBF3JT1SRD	—
	152		VBF3JU1SRA	VBF3JU1SRB	VBF3JU1SRC	VBF3JU1SRD	—
	197		VBF3J11SRA	VBF3J11SRB	VBF3J11SRC	VBF3J11SRD	—
	254		VBF3J21SRA	VBF3J21SRB	VBF3J21SRC	VBF3J21SRD	—
	327		VBF3J31SRA	VBF3J31SRB	VBF3J31SRC	VBF3J31SRD	—
5"	144		VBF3KU1SRA	VBF3KU1SRB	VBF3KU1SRC	VBF3KU1SRD	—
	185		VBF3K11SRA	VBF3K11SRB	VBF3K11SRC	VBF3K11SRD	—
	240		VBF3K21SRA	VBF3K21SRB	VBF3K21SRC	VBF3K21SRD	—
	309		VBF3K31SRA	VBF3K31SRB	VBF3K31SRC	VBF3K31SRD	—
	400		VBF3K41SRA	VBF3K41SRB	VBF3K41SRC	—	—
6"	208		VBF3L11SRA	VBF3L11SRB	VBF3L11SRC	VBF3L11SRD	—
	268		VBF3L21SRA	VBF3L21SRB	VBF3L21SRC	VBF3L21SRD	—
	346		VBF3L41SRA	VBF3L41SRB	VBF3L41SRC	—	—
	441		VBF3L51SRA	VBF3L51SRB	VBF3L51SRC	—	—
	577		VBF3L61SRA	VBF3L61SRB	VBF3L61SRC	—	—
	650		VBF3L71SRA	VBF3L71SRB	VBF3L71SRC	—	—



3-Way

NEW PHOTO



VALVE SELECTION

NPT Globe Valves 1/2- 3"

With Dedicated Valve Actuators

For more than 50 years, Honeywell Globe Valves (V5011/13, VGF) have provided precise control for most applications.

Globe valves provide the rangeability and close-off needed to keep tight control of the environment.



Actuator Features		Non-Fail Safe					
Actuator O.S. Number		ML7984A4009	ML6984A4000	ML7420A3055	ML7420A3063	ML6420A3049	ML6420A3056
Power Supply	Voltage	24 Vac / 28 Vdc	24 Vac / 28 Vdc	24 Vac	24 Vac	24 Vac	24 Vac
	Frequency	0 / 50 / 60 Hz	0 / 50 / 60 Hz	50 / 60 Hz	50 / 60 Hz	50 / 60 Hz	50 / 60 Hz
	Power	12 VA	12 VA	7 VA	7 VA	6 VA	6 VA
Actuator Stem Force	(lbs.)	160	160	135	135	135	135
Control	(0)2-10 Vdc	Built-in		•*	•*		
	4-20 mA (external 500 Ohm Resistor)		•			•	•
	Floating		•			•	•
	Two-Position SPDT						
	Two-Position SPST	•					
	135 Ohm	Stay in place	Stay in place	Stay in place	Stay in place	Stay in place	Stay in place
Fail Safe Action		Stem Up	Stem Up	Stem Up	Stem Up	Stem Up	Stem Up
Normal Position (no signal)	(field configurable)	0.5 - 1 self adj	0.5 - 1 self adj	0.75	0.75	0.75	0.75
Actuator Stroke	(inches)	63	63	60	30	60	30
Timing	(seconds at 0.75" stroke)			43196000-001	43196000-001	43196000-001	43196000-001
Aux Switch	1 x SPDT Add-On			43191680-105	43191680-105	43191680-105	43191680-105
	2 x SPDT Add-On			•	•		
Feedback	2-10 Vdc Built-in	272630D	272630D				
	2-10 Vdc Add-On					43191679-111	43191679-111
	220 Ohm Add-On					43191679-112	43191679-111
	10 kOhm Add-On	200976B	200976B	200976B	200976B		

	Valve Size (inches)	Cv	Max Static Water Pressure	Max Steam Pressure / Temperature	Flow Characteristic	Valve Action	Valve OS Number	Close-off Pressure, psid						
2-Way Water Valves Straight Through	1/2"	0.73	217 psi @ 248 F	15 psi (2-position)	Equal %	Stem down to close	V5011N1008	230	230	230	230	230	230	
		1.16					V5011N1016	230	230	230	230	230	230	
		1.85					V5011N1024	230	230	230	230	230	230	
		2.9					V5011N1032	230	230	230	230	230	230	
		2.9					V5011N3004	230	230	230	230	230	230	
		4.7					V5011N1040	230	230	230	230	230	230	
	2-Way Steam Valves Straight Through	3/4"	7.3	217 psi @ 248 F	100 psig / 337 F	Linear	Stem down to close	V5011N3012	230	230	230	230	230	230
			7.3					V5011N1057	230	230	230	230	230	230
			11.7					V5011N3020	230	230	230	230	230	230
			11.7					V5011N1065	193	193	163	163	163	163
			18.7					V5011N3038	193	193	163	163	163	163
			18.7					V5011N1073	123	123	104	104	104	104
		2"	46.8	250 psi @ 100F	N / A	Linear B-AB / Equal % A-AB	Stem up closes A-AB	V5011N3046	123	123	104	104	104	104
			29.3					V5011N1081	79	79	67	67	67	67
			46.8					V5011N1099	44	44	37	37	37	37
			63					V5011F1105	33	33	28	28	28	28
3-Way Water Valves Mixing	1/2"	2.9	217 psi @ 248 F	N / A	Linear B-AB / Equal % A-AB	Stem up closes A-AB	V5011F1113	19	19	16	16	16	16	
		4.7					V5011N2006	100	100	100	100	100	100	
	7.3	V5011N2014					100	100	100	100	100	100		
	11.7	V5011N2022					100	100	100	100	100	100		
	18.7	V5011N2030					100	100	100	100	100	100		
	29.3	V5011N2048					100	100	100	100	100	100		
	46.8	V5011N2055					100	100	100	100	100	100		
	63	V5011N2063					100	100	100	100	100	100		
	100	V5011N2071					100	100	100	100	100	100		
	100	V5011N2089					79	79	67	67	67	67		
2"	46.8	250 psi @ 100F	N / A	Linear B-AB / Equal % A-AB	Stem up closes A-AB	V5011N2097	44	44	37	37	37	37		
	29.3					V5011G1111	33	33	28	28	28	28		
	46.8					V5011G1129	19	19	16	16	16	16		
	2.9					V5013N1030	230	230	230	230	230	230		
	4.7					V5013N1048	230	230	230	230	230	230		
	7.3					V5013N1055	230	230	230	230	230	230		
	11.7					V5013N1063	193	193	163	163	163	163		
	18.7					V5013N1071	123	123	104	104	104	104		
1-1/2"	29.3	250 psi @ 100F	N / A	Linear B-AB / Equal % A-AB	Stem up closes A-AB	V5013N1089	79	79	67	67	67			
	46.8					V5013N1097	44	44	37	37	37	37		

NPT Globe Valves 1/2-3"

With Dedicated Valve Actuators



Common Features

- ANSI body class 150
- Close-off pressure = maximum differential pressure
- Maximum static water pressure (250°F): 240 psi
- Maximum steam pressure
2-way steam valves, 337°F: 100 psi
2-way water valves: 15 psi
- Stem travel: 0.75"
- Rangeability: 50:1
- Leakage < 0.05% of Cv
- Body material: Red brass, stainless steel stem (steam valve has stainless steel trim)

Actuator Features	Non-Fail Safe		Fail Safe			
	ML7421A1032	ML6421A1017	ML7425A3013	ML7425B3012	ML6425A3022	ML6425B3013
Actuator O.S. Number						
Power Supply	Voltage	24 Vac	24 Vac	24 Vac	24 Vac	24 Vac
	Frequency	50 / 60 Hz	50 / 60 Hz	50 / 60 Hz	50 / 60 Hz	50 / 60 Hz
	Power	12 VA	11 VA	12 VA	12 VA	11 VA
Actuator Stem Force	(lbs.)	404	404	135	135	135
Control	(0)2-10 Vdc	•*		•*	•*	
	4-20 mA (external 500 Ohm Resistor)		•		•	•
	Floating		•		•	•
	Two-Position SPDT				•	•
	Two-Position SPST					
	135 Ohm	Stay in place	Stay in place	Stem Down	Stem Up	Stem Down
Fail Safe Action		Stem Up	Stem Up	Stem Up	Stem Up	Stem Up
Normal Position (no signal)	(field configurable)	0.75	0.75	0.75	0.75	0.75
Actuator Stroke	(inches)	90	90	90	90	90
Timing	(seconds at 0.75" stroke)	43196000-001	43196000-001	43196000-001	43196000-001	43196000-001
Aux Switch	1 x SPDT Add-On	43191680-102	43191680-102	43191680-105	43191680-105	43191680-105
	2 x SPDT Add-On	•		•	•	
Feedback	2-10 Vdc Built-in					
	2-10 Vdc Add-On		43191679-101			43191679-111
	220 Ohm Add-On					43191679-112
	10 kOhm Add-On	200976B	200976B	200976B	200976B	

VALVE SELECTION

	Valve Size (inches)	Cv	Max Static Water Pressure	Max Steam Pressure / Temperature	Flow Characteristic	Valve Action	Valve OS Number	Close-off Pressure, psid					
2-Way Water Valves Straight Through	1/2"	0.73	217 psi @ 248 F	15 psi (2-position)	Equal %	Stem down to close	V5011N1008		230*	230**	230*	230**	
		1.16					V5011N1016		230*	230**	230*	230**	
		1.85					V5011N1024		230*	230**	230*	230**	
		2.9					V5011N1032		230*	230**	230*	230**	
		2.9					V5011N3004		230**	230*	230**	230*	
		4.7					V5011N1040		230*	230**	230*	230**	
	2-Way Steam Valves Straight Through	3/4"	7.3	217 psi @ 248 F	100 psig / 337 F	Linear	Stem down to close	V5011N3012		230*	230**	230*	230**
			7.3					V5011N1057		230*	230**	230*	230**
		11.7	V5011N3020						230**	230*	230**	230*	
		11.7	V5011N1065					230	230	163*	163**	163*	163**
		18.7	V5011N3038					230	230	163**	163*	163**	163*
		18.7	V5011N1073					230	230	104*	104**	104*	104**
		29.3	V5011N3046					230	230	104**	104*	104**	104*
		46.8	V5011N1081					221	221	67*	67**	67*	67**
		63	V5011N1099					126	126	37*	37**	37*	37**
		100	V5011F1105					100	100	28*	28**	28*	28**
3-Way Water Valves Mixing	1/2"	0.73	217 psi @ 248 F	N / A	Linear B-AB / Equal % A-AB	Stem up closes A-AB	V5011F1113	61	61	16*	16**	16*	16**
		1.16					V5011N2006		100*	100**	100*	100**	
	1.85	V5011N2014						100*	100**	100*	100**		
	2.9	V5011N2022						100*	100**	100*	100**		
	4.7	V5011N2030						100*	100**	100*	100**		
	7.3	V5011N2048						100*	100**	100*	100**		
	11.7	V5011N2055						100*	100**	100*	100**		
	18.7	V5011N2063					100	100	100*	100**	100*	100**	
	29.3	V5011N2071					100	100	100*	100**	100*	100**	
	46.8	V5011N2089					100	100	67*	67**	67*	67**	
2-Way Water Valves Mixing	2-1/2"	63	250 psi @ 100F	N / A	Linear B-AB / Equal % A-AB	Stem up closes A-AB	V5011N2097	100	100	37*	37**	37*	37**
		100					V5011G1111	100	100	28*	28**	28*	28**
	2.9	V5011G1129					61	61	16*	16**	16*	16**	
	4.7	V5013N1030							230	230	230	230	
	7.3	V5013N1048							230	230	230	230	
	11.7	V5013N1055							230	230	230	230	
	18.7	V5013N1063					230	230	163	163	163	163	
	29.3	V5013N1071					230	230	104	104	104	104	
46.8	V5013N1089	221	221	67	67	67	67						
	2"	46.8						37	37	37	37		

* valve is Normally Closed on loss of power
** valve is Normally Open on loss of power.

NPT Globe Valves 1/2- 3"

With Direct Coupled Actuators and Valve Linkage

Common Features

- ANSI body class 150
- Close-Off pressure = maximum differential pressure
- Maximum static water pressure (250°F): 240 psi
- Maximum steam pressure 2-way steam valves, 337°F: 100 psi
2-way water valves: 15 psi
- Stem travel: 0.75"
- Rangeability: 50:1
- Leakage < 0.05% of Cv
- Body material: Red brass, stainless steel stem (steam valve has stainless steel trim)



Actuator Features		Non-Fail Safe					
		ML7161A2008	ML6161B2024	ML7174A2001	ML6174B2019	MN7505A2001 MN7505A2209	MN6105A1011 MN6105A1201
Actuator O.S. Number							
	Power Supply	Voltage	24 Vac	24 Vac	24 Vac	24 Vac	24 Vac
	Frequency	50 / 60 Hz	50 / 60 Hz	50 / 60 Hz	50 / 60 Hz	50 / 60 Hz	50 / 60 Hz
	Power	5.4 VA	1.8 VA	5.4 VA	2.4 VA	5 VA	5 VA
Actuator Torque	(lb. -in.)	35	35	70	70	44	44
Linkage Stem Force	(lbs.)	46	46	93	93	58	58
Control	(0)2-10 Vdc	•		•		•	
	4-20 mA (external 500 Ohm Resistor)	•		•		•	
	Floating		•		•	•	•
	Two-Position SPDT		•		•	•	•
	Two-Position SPST					•	•
Fail Safe Action		Stay in Place	Stay in Place	Stay in Place	Stay in Place	Stay in Place	Stay in Place
Normal Position (no signal)	(field configurable)	Stem Up/Down	Stem Up/Down	Stem Up/Down	Stem Up/Down	Stem Up/Down	Stem Up/Down
Actuator Stroke	(inches)	90°	90°	90°	90°	95°	95°
Timing	(seconds at 0.75" stroke)	90	90	90	90	95	95
Aux Switch	2 x SPDT Built In					0 / 2	0 / 2
	1 x SPDT Add-On	201052A	201052A	201052A	201052A		
	2 x SPDT Add-On	201052B	201052B	201052B	201052B	SSW2	SSW2
Feedback	(0)2-10 Vdc Built In					•	
	500 Ohm Add-On	200976A	200976A	200976A	200976A		
	2 kOhm Add-On	200976B	200976B	200976B	200976B		

Valve Size (inches)	Cv	Max Static Water Pressure	Max Steam Pressure / Temperature	Flow Characteristic	Valve Action	Valve OS Number	Close-off Pressure, psid					
2-Way Water Valves Straight Through	1/2"	217 psi @ 248 F	15 psi (2-position)	Equal %	Stem down to close	V5011N1008	230	230	230	230	230	230
					Stem down to close	V5011N1016	230	230	230	230	230	230
					Stem down to close	V5011N1024	230	230	230	230	230	230
					Stem down to close	V5011N1032	230	230	230	230	230	230
					Stem up to close	V5011N3004	230	230	230	230	230	230
					Stem down to close	V5011N1040	143	143	230	230	188	188
	3/4"	217 psi @ 248 F	15 psi (2-position)	Equal %	Stem up to close	V5011N3012	143	143	230	230	188	188
					Stem down to close	V5011N1057	69	69	156	156	91	91
					Stem up to close	V5011N3020	69	69	156	156	91	91
					Stem down to close	V5011N1065	47	47	109	109	63	63
					Stem up to close	V5011N3038	47	47	109	109	63	63
					Stem down to close	V5011N1073	29	29	69	69	39	39
					Stem up to close	V5011N3046	29	29	69	69	39	39
					Stem down to close	V5011N1081	17	17	44	44	24	24
					Stem down to close	V5011N1099	8	8	24	24	12	12
					Stem down to close	V5011F1105	5	5	16	16	7	7
Stem down to close	V5011F1113	2	2	9	9	3	3					
2-Way Steam Valves Straight Through	1/2"	217 psi @ 248 F	100 psig / 337 F	Linear	Stem down to close	V5011N2006	100	100	100	100	100	100
						V5011N2014	100	100	100	100	100	100
						V5011N2022	100	100	100	100	100	100
						V5011N2030	100	100	100	100	100	100
						V5011N2048	100	100	100	100	100	100
						V5011N2055	69	69	100	100	91	91
	3/4"	217 psi @ 248 F	100 psig / 337 F	Linear	Stem down to close	V5011N2063	47	47	100	100	63	63
						V5011N2071	29	29	69	69	39	39
						V5011N2089	17	17	44	44	24	24
						V5011N2097	8	8	24	24	12	12
						V5011G1111	5	5	16	16	7	7
						V5011G1129	2	2	9	9	3	3
3-Way Water Valves Mixing	217 psi @ 248 F	N / A	Linear B-AB / Equal % A-AB	Stem up closes A-AB	V5013N1030	230	230	230	230	230	230	
					V5013N1048	143	143	230	230	188	188	
					V5013N1055	69	69	156	156	91	91	
					V5013N1063	47	47	109	109	63	63	
					V5013N1071	29	29	69	69	39	39	
					V5013N1089	17	17	44	44	24	24	
					V5013N1097	8	8	24	24	12	12	
					2"	46.8	250 psi @ 100F	N / A	Linear B-AB / Equal % A-AB	Stem up closes A-AB	V5013N1097	8

NPT Globe Valves 1/2- 3"

With Direct Coupled Actuators and Valve Linkage

**Q5020A1003
Required**



Actuator Features		Non-Fail Safe					
Actuator O.S. Number		MM7510A2001 MM7510A2209	MM6110A1003 MM6110A1201	MM7220A2007 MM7220A2205	MM6120A1002 MM6120A1200	MM7234A2008	MM6134A1003
	Power Supply Voltage	24 Vac	24 Vac	24 Vac	24 Vac	24 Vac	24 Vac
	Frequency	50 / 60 Hz	50 / 60 Hz	50 / 60 Hz	50 / 60 Hz	50 / 60 Hz	50 / 60 Hz
	Power	5 VA	5 VA	6 VA	6 VA	9 VA	9 VA
Actuator Torque	(lb. -in.)	88	88	175	175	300	300
Linkage Stem Force	(lbs.)	117	117	234	234	402	402
Control	(0)2-10 Vdc	•		•		•	
	4-20 mA (external 500 Ohm Resistor)	•		•		•	
	Floating	•	•	•	•	•	•
	Two-Position SPDT	•	•	•	•	•	•
	Two-Position SPST	•	•	•	•	•	•
Fail Safe Action		Stay in Place	Stay in Place	Stay in Place	Stay in Place	Stay in Place	Stay in Place
Normal Position (no signal)	(field configurable)	Stem Up/Down	Stem Up/Down	Stem Up/Down	Stem Up/Down	Stem Up/Down	Stem Up/Down
Actuator Stroke	(inches)	95°	95°	95°	95°	95°	95°
Timing	(seconds at 0.75" stroke)	95	95	95	95	95	95
Aux Switch	2 x SPDT Built In	0 / 2	0 / 2	0 / 2	0 / 2		
	1 x SPDT Add-On						
	2 x SPDT Add-On	SSW2	SSW2	SW2-US	SW2-US	SW2-US	SW2-US
Feedback	(0)2-10 Vdc Built In	•		•		•	
	500 Ohm Add-On						
	2 kOhm Add-On						

VALVE SELECTION

	Valve Size (inches)	Cv	Max Static Water Pressure	Max Steam Pressure / Temperature	Flow Characteristic	Valve Action	Valve OS Number	Close-off Pressure, psid					
2-Way Water Valves Straight Through	1/2"	0.73	217 psi @ 248 F	15 psi (2-position)	Equal %	Stem down to close	V5011N1008	230	230	230	230	230	230
		1.16					V5011N1016	230	230	230	230	230	230
		1.85					V5011N1024	230	230	230	230	230	230
		2.9					V5011N1032	230	230	230	230	230	230
		2.9					V5011N3004	230	230	230	230	230	230
		4.7					V5011N1040	230	230	230	230	230	230
	4.7	V5011N3012	230	230	230	230	230	230					
	3/4"	7.3	V5011N1057	192	192	230	230	230	230				
	3/4"	7.3	V5011N3020	192	192	230	230	230	230				
	1"	11.7	V5011N1065	135	135	230	230	230	230				
	1"	11.7	V5011N3038	135	135	230	230	230	230				
	1-1/4"	18.7	V5011N1073	85	85	168	168	230	230				
	1-1/4"	18.7	V5011N3046	85	85	168	168	230	230				
	1-1/2"	29.3	V5011N1081	55	55	113	113	180	180				
	2"	46.8	V5011N1099	30	30	63	63	103	103				
	2-1/2"	63	V5011F1105	19	19	42	42	74	74				
	3"	100	V5011F1113	11	11	26	26	45	45				
	2-Way Steam Valves Straight Through	1/2"	0.73	217 psi @ 248 F	100 psig / 337 F	Linear	Stem down to close	V5011N2006	100	100	100	100	100
1.16			V5011N2014					100	100	100	100	100	100
1.85			V5011N2022					100	100	100	100	100	100
2.9			V5011N2030					100	100	100	100	100	100
4.7			V5011N2048					100	100	100	100	100	100
4.7			V5011N2055					100	100	100	100	100	100
3/4"		7.3	V5011N2063	100	100	100	100	100	100				
1"		11.7	V5011N2071	85	85	100	100	100	100				
1-1/4"		18.7	V5011N2089	55	55	100	100	100	100				
1-1/2"		29.3	V5011N2097	30	30	58	58	100	100				
2"		46.8	V5011G1111	19	19	42	42	74	74				
2-1/2"		63	V5011G1129	11	11	26	26	45	45				
3"		100	V5013N1030	230	230	230	230	230	230				
3-Way Water Valves Mixing		1/2"	2.9	217 psi @ 248 F	N / A	Linear B-AB / Equal % A-AB	Stem up closes A-AB	V5013N1048	230	230	230	230	230
	1/2"	4.7	V5013N1055					192	192	230	230	230	230
	3/4"	7.3	V5013N1063					135	135	230	230	230	230
	1"	11.7	V5013N1071					85	85	168	168	230	230
	1-1/4"	18.7	V5013N1089					55	55	105	105	180	180
	1-1/2"	29.3	V5013N1097					30	30	103	103	103	103

NPT Globe Valves 1/2- 3"

With Direct Coupled Spring Return Actuators and Valve Linkage

Common Features

- ANSI body class 150
- Close-Off pressure = maximum differential pressure
- Maximum static water pressure (250°F): 240 psi
- Maximum steam pressure 2-way steam valves, 337°F: 100 psi
2-way water valves: 15 psi
- Stem travel: 0.75"
- Rangeability: 50:1
- Leakage < 0.05% of Cv
- Body material: Red brass, stainless steel stem (steam valve has stainless steel trim)



Actuator Features		Fail Safe				
Actuator O.S. Number		MS7505A2030 MS7505A2130	MS8105A1030 MS8105A1130	MS4105A1030 MS4105A1130	MS7510A2008 MS7510A2206 MS7510H2209	MS8110A1008 MS8110A1206
Power Supply	Voltage	24 Vac	24 Vac	100-250 Vac	24 Vac	24 Vac
	Frequency	50 / 60 Hz	50 / 60 Hz	60 Hz	50 / 60 Hz	50 / 60 Hz
	Power	7.5VA	8 VA	11VA	14 VA	30 VA
Actuator Torque	(lb.-in.)	44	44	44	88	88
Linkage Stem Force	(lbs.)	58	58	58	117	117
Control	(0)2-10 Vdc	•			•	
	4-20 mA (external 500 Ohm Resistor)	•			•	
	Floating	•			•	
	Two-Position SPDT	•			•	
	Two-Position SPST	•	•		•	•
Fail Safe Action		Configurable Open/Closed	Configurable Open/Closed	Configurable Open/Closed	Configurable Open/Closed	Configurable Open/Closed
Normal Position (no signal) (field configurable)		Stem Up/Down	Stem Up/Down	Stem Up/Down	Stem Up/Down	Stem Up/Down
Actuator Stroke	(inches)	95°	95°	95°	95°	95°
Timing	(seconds at 0.75" stroke)	90	90	90	90	90
Aux Switch	SPDT Built In	0 / 1	0 / 1	0 / 1	0 / 2 / 2	0 / 2
	2 x SPDT Add-On				SW2-US	SW2-US
Feedback	2-10 Vdc Built In	•			•	

	Valve Size (inches)	Cv	Max Static Water Pressure	Max Steam Pressure / Temperature	Flow Characteristic	Valve Action	Valve OS Number	Close-off Pressure, psid								
2-Way Water Valves Straight Through	1/2"	0.73	217 psi @ 248 F	15 psi (2-position)	Equal %	Stem down to close	V5011N1008	230	230	230	230	230				
		1.16					V5011N1016	230	230	230	230	230				
		1.85					V5011N1024	230	230	230	230	230				
		2.9					V5011N1032	230	230	230	230	230				
		2.9					V5011N3004	230	230	230	230	230				
		4.7					V5011N1040	184	184	184	230	230				
	4.7	V5011N3012	184	184	184	230	230									
	3/4"	7.3	250 psi @ 100F	100 psig / 337 F	Linear	Stem down to close	V5011N1057	79	79	79	150	150				
	3/4"	7.3					V5011N3020	79	79	79	150	150				
	1"	11.7					V5011N1065	66	66	66	136	136				
	1"	11.7					V5011N3038	66	66	66	136	136				
	1-1/4"	18.7					V5011N1073	40	40	40	84	84				
	1-1/4"	18.7					V5011N3046	40	40	40	84	84				
	1-1/2"	29.3	250 psi @ 100F	N / A	Linear B-AB / Equal % A-AB	Stem up closes A-AB	V5011N1081	26	26	26	55	55				
	2"	46.8					V5011N1099	13	13	13	30	30				
	2-1/2"	63					V5011F1105	9	9	9	21	21				
3"	100	V5011F1113					6	6	6	13	13					
2-Way Steam Valves Straight Through	1/2"	0.73					217 psi @ 248 F	100 psig / 337 F	Linear	Stem down to close	V5011N2006	100	100	100	100	100
		1.16									V5011N2014	100	100	100	100	100
		1.85	V5011N2022	100	100	100					100	100				
		2.9	V5011N2030	100	100	100					100	100				
		4.7	V5011N2048	100	100	100					100	100				
		4.7	V5011N2055	79	79	79					100	100				
	3/4"	7.3	V5011N2063	66	66	66	100	100								
	1"	11.7	V5011N2071	40	40	40	84	84								
	1-1/4"	18.7	V5011N2089	26	26	26	55	55								
	1-1/2"	29.3	V5011N2097	13	13	13	30	30								
2"	46.8	V5011G1111	9	9	9	21	21									
2-1/2"	63	V5011G1129	6	6	6	13	13									
3"	100	V5013N1030	230	230	230	230	230									
3-Way Water Valves Mixing	1/2"	2.9	217 psi @ 248 F	N / A	Linear B-AB / Equal % A-AB	Stem up closes A-AB	V5013N1048	184	184	184	230	230				
	1/2"	4.7					V5013N1055	79	79	79	150	150				
	3/4"	7.3					V5013N1063	66	66	66	136	136				
	1"	11.7					V5013N1071	40	40	40	84	84				
	1-1/4"	18.7					V5013N1089	26	26	26	55	55				
	1-1/2"	29.3					V5013N1097	13	13	13	30	30				
	2"	46.8														

NPT Globe Valves 1/2"-3"

With Direct Coupled Spring Return Actuators and Valve Linkage

**Q5020A1003
Required**



Actuator Features		Fail Safe			
Actuator O.S. Number		MSA110A1002 MSA110A1200	MS7520A2007 MS7520A2205 MS7520H2208	MS8120A1007 MS8120A1205	MSA120A1001 MSA120A1209
Power Supply	Voltage	100-250 Vac	24 Vac	24 Vac	100-250 Vac
	Frequency	60 Hz	50 / 60 Hz	50 / 60 Hz	60 Hz
	Power	45 VA	16 VA	40 VA	60 VA
Actuator Torque	(lb.-in.)	88	175	175	175
Linkage Stem Force	(lbs.)	117	234	234	234
Control	(0)2-10 Vdc		•		
	4-20 mA (external 500 Ohm Resistor)		•		
	Floating		•		
	Two-Position SPDT		•		
	Two-Position SPST	•	•	•	•
Fail Safe Action		Configurable Open/Closed	Configurable Open/Closed	Configurable Open/Closed	Configurable Open/Closed
Normal Position (no signal)	(field configurable)	Stem Up/Down	Stem Up/Down	Stem Up/Down	Stem Up/Down
Actuator Stroke	(inches)	95°	95°	95°	95°
Timing	(seconds at 0.75" stroke)	90	90	90	90
Aux Switch	SPDT Built In	0 / 2	0 / 2 / 2	0 / 2	0 / 2
	2 x SPDT Add-On	SW2-US	SW2-US	SW2-US	SW2-US
Feedback	2-10 Vdc Built In		•		

	Valve Size (inches)	Cv	Max Static Water Pressure	Max Steam Pressure / Temperature	Flow Characteristic	Valve Action	Valve OS Number	Close-off Pressure, psid							
2-Way Water Valves Straight Through	1/2"	0.73	217 psi @ 248 F	15 psi (2-position)	Equal %	Stem down to close	V5011N1008	230	230	230	230				
		1.16					V5011N1016	230	230	230	230				
		1.85					V5011N1024	230	230	230	230				
		2.9					V5011N1032	230	230	230	230				
		4.7					V5011N3004	230	230	230	230				
		4.7					V5011N1040	230	230	230	230				
	3/4"	7.3	217 psi @ 248 F	15 psi (2-position)	Equal %	Stem down to close	V5011N1057	150	230	230	230				
	3/4"	7.3					V5011N3020	150	230	230	230				
	1"	11.7					V5011N1065	136	230	230	230				
	1"	11.7					V5011N3038	136	230	230	230				
	1-1/4"	18.7					V5011N1073	84	171	171	171				
	1-1/4"	18.7					V5011N3046	84	171	171	171				
	1-1/2"	29.3	250 psi @ 100F	100 psig / 337 F	Linear	Stem down to close	V5011N1081	55	113	113	113				
	2"	46.8					V5011N1099	30	63	63	63				
	2-1/2"	63					V5011F1105	21	45	45	45				
3"	100	V5011F1113					13	27	27	27					
2-Way Steam Valves Straight Through	1/2"	0.73					217 psi @ 248 F	100 psig / 337 F	Linear	Stem down to close	V5011N2006	100	100	100	100
		1.16									V5011N2014	100	100	100	100
		1.85	V5011N2022	100	100	100					100				
		2.9	V5011N2030	100	100	100					100				
		4.7	V5011N2048	100	100	100					100				
		4.7	V5011N2055	100	100	100					100				
	3/4"	7.3	250 psi @ 100F	100 psig / 337 F	Linear	Stem down to close	V5011N2063	100	100	100	100				
	1"	11.7					V5011N2071	84	100	100	100				
	1-1/4"	18.7					V5011N2089	55	100	100	100				
	1-1/2"	29.3					V5011N2097	30	63	63	63				
2"	46.8	V5011G1111					21	45	45	45					
2-1/2"	63	V5011G1129					13	27	27	27					
3"	100	217 psi @ 248 F	N / A	Linear B-AB / Equal % A-AB	Stem up closes A-AB	V5013N1030	230	230	230	230					
1/2"	2.9					V5013N1048	230	230	230	230					
1/2"	4.7					V5013N1055	150	230	230	230					
3/4"	7.3					V5013N1063	136	230	230	230					
1"	11.7					V5013N1071	84	171	171	171					
1-1/4"	18.7					V5013N1089	55	113	113	113					
1-1/2"	29.3	217 psi @ 248 F	N / A	Linear B-AB / Equal % A-AB	Stem up closes A-AB	V5013N1097	30	63	63	63					
2"	46.8														

VALVE SELECTION

Flanged Globe Valves 2½- 3"

With Direct Coupled Actuators and Valve Linkage

Common Features

- ANSI body class 125 or 250
- Close-off pressure = Maximum differential pressure
- Maximum static water pressure: Up to 400 psi
- Maximum steam pressure (VGF, 2-pos or modulating): 100 psi
- Maximum steam pressure (V5011, 2-pos): 15 psi
- Stem travel: 0.75"
- Rangeability: 50:1
- Body material: Cast iron
- Body trim: Stainless steel stem, brass seat (V5011/13), stainless steel (VGF)



Actuator Features		Non-fail Safe			
Actuator O.S. Number		ML7174A2001	ML6174B2019	MN7510A2001 MN7505A2209	MN6110A1003 MN6110A1201
Power Supply	Voltage	24 Vac	24 Vac	24 Vac	24 Vac
	Frequency	50 / 60 Hz	50 / 60 Hz	50 / 60 Hz	50 / 60 Hz
	Power	5.4 VA	2.4 VA	5 VA	5 VA
Actuator Torque	(lb.-in.)	70	70	88	88
Linkage Stem Force	(lbs.)	93	93	117	117
Control	(0)2-10 Vdc	•		•	
	4-20 mA (external 500 Ohm Resistor)	•		•	
	Floating		•	•	•
	Two-Position SPDT		•	•	•
	Two-Position SPST			•	•
Fail Safe Action		Stay in Place	Stay in Place	Stay in Place	Stay in Place
Normal Position (no signal)	(field configurable)	Stem Up/Down	Stem Up/Down	Stem Up/Down	Stem Up/Down
Actuator Stroke	(degrees)	90°	90°	95°	95°
Timing	(seconds)	90	90	95	95
High Temperature Kit	Steam Application	43196000-001	43196000-001	43196000-001	43196000-001
Aux Switch	SPDT Built In			0 / 2	0 / 2
	1 x SPDT Add-On	201052A	201052A		
	2 x SPDT Add-On	201052B	201052B	SSW2	SSW2
Feedback	(0)2-10 Vdc Built In			•	
	500 Ohm Add-On	200976A	200976A		
	2 kOhm Add-On	200976B	200976B		

2-Way Water & Steam Valves
ANSI Class III (< 0.05% Cv) Seat Leakage

2-Way Water & Steam Valves
ANSI Class IV (< 0.01% Cv) Seat Leakage

3-Way Water Valves

Valve Size (inches)	Cv	Valve Type	ANSI Class	Max Static Water Pressure	Max Steam Pressure / Temperature	Flow Characteristic	Valve Action	Valve OS Number	Close-off Pressure, psid									
2 1/2"	63	Standard	125	150 psi @ 240 F	15 psi (2-position)	Equal %	Stem down to close	V5011A1734	21	21	27	27						
				175 psi @ 130 F				VG21ES25	18	18	34	34						
				175 psi @ 130 F				VG21LS25	18	18	34	34						
	100		400 psi @ 130 F	15 psi (2-position)	Equal %	VG22ES25		18	18	34	34							
			150 psi @ 240 F			V5011A1767		9	9	11	11							
			175 psi @ 130 F			VG21ES30		9	9	16	16							
125	175 psi @ 130 F	125 psig / 353 F	Equal %	VG21LS30	9	9	16	16										
	400 psi @ 130 F			Equal %	VG22ES30	9	9	16	16									
2 1/2"	70	Pressure Balanced	125		175 psi @ 130 F	125 psig / 353 F	Equal %	Stem down to close	VG21EP25	100	100	100	100					
		Standard		VG21ES25														
		Pressure Balanced		VG21LP25					100	100	100	100						
		Standard		VG21LS25														
		Standard		250					400 psi @ 130 F	Equal %	VG22ES25							
	3"	115	Pressure Balanced	125	175 psi @ 130 F		Equal %		VG21EP30									
		115	Standard				Equal %		VG21ES30									
		120	Pressure Balanced				Linear		VG21LP30									
		125	Standard				Linear		VG21LS30									
		120	Standard				250		400 psi @ 130 F	Equal %	VG22ES30							
2 1/2"	63	Mixing	125	150 psi @ 240 F	N / A	Constant Total	Stem up closes A-AB	V5013B1003	21	21	27	27						
		Diverting		150 psi @ 240 F		Constant Total		Stem up closes B-AB	V5013C1001	21	21	27	27					
		Mixing		175 psi @ 130 F		Equal % A-AB			Stem up closes A-AB	VG31EM25	23	23	44	44				
		Diverting		175 psi @ 130 F		Linear, Constant Total				Stem up closes B-AB	VG31LD25	18	18	34	34			
		Mixing		400 psi @ 130 F		Equal % A-AB					Stem up closes A-AB	VG32EM25	23	23	44	44		
		Diverting		250		400 psi @ 130 F						Linear, Constant Total	Stem up closes B-AB	VG32LD25	18	18	34	34
	3"	100	Mixing	125		150 psi @ 240 F	Constant Total					Stem up closes A-AB		V5013B1011	9	9	11	11
		100	Diverting			150 psi @ 240 F	Constant Total	Stem up closes B-AB						V5013C1019	9	9	11	11
		120	Mixing			175 psi @ 130 F	Equal % A-AB		Stem up closes A-AB					VG31EM30	15	15	29	29
		120	Diverting			175 psi @ 130 F	Linear, Constant Total			Stem up closes B-AB				VG31LD30	9	9	16	16
		115	Mixing			250	400 psi @ 130 F				Equal % A-AB			Stem up closes A-AB	VG32EM30	15	15	29
		120	Diverting			250	400 psi @ 130 F				Linear, Constant Total		Stem up closes B-AB		VG32LD30	9	9	16

Flanged Globe Valves 2½- 3"

With Direct Coupled Actuators and Valve Linkage

**Q5020A1003
Required**



Actuator Features		Non-fail Safe			
		MN7220A2007	MN6120A1002	MN7234A2008	MN6134A1003
Actuator O.S. Number					
Power Supply	Voltage	24 Vac	24 Vac	24 Vac	24 Vac
	Frequency	50 / 60 Hz	50 / 60 Hz	50 / 60 Hz	50 / 60 Hz
	Power	6 VA	6 VA	9 VA	9 VA
Actuator Torque	(lb.-in.)	175	175	300	300
Linkage Stem Force	(lbs.)	234	234	402	402
Control	(0)2-10 Vdc	•		•	
	4-20 mA (external 500 Ohm Resistor)	•		•	
	Floating	•	•		•
	Two-Position SPDT	•	•		•
	Two-Position SPST	•	•	•	•
Fail Safe Action		Stay in Place	Stay in Place	Stay in Place	Stay in Place
Normal Position (no signal) (field configurable)		Stem Up/Down	Stem Up/Down	Stem Up/Down	Stem Up/Down
Actuator Stroke	(degrees)	95°	95°	95°	95°
Timing	(seconds)	95	95	95	95
High Temperature Kit	Steam Application	43196000-001	43196000-001	43196000-001	43196000-001
Aux Switch	SPDT Built In	0 / 2	0 / 2		
	1 x SPDT Add-On				
	2 x SPDT Add-On	SW2-US	SW2-US	SW2-US	SW2-US
Feedback	(0)2-10 Vdc Built In	•		•	
	500 Ohm Add-On				
	2 kOhm Add-On				

VALVE SELECTION

Valve Size (inches)	Cv	Valve Type	ANSI Class	Max Static Water Pressure	Max Steam Pressure / Temperature	Flow Characteristic	Valve Action	Valve OS Number	Close-off Pressure, psid																	
2 1/2"	63	Standard	125	150 psi @ 240 F	15 psi (2-position)	Equal %	Stem down to close	V5011A1734	52	52	88	88														
									70	175 psi @ 130 F	125 psig / 353 F	Equal %	VGF21ES25	52	52											
														100	175 psi @ 130 F	125 psig / 353 F	Linear	VGF21LS25	52	52						
	115																		175 psi @ 130 F	125 psig / 353 F	Linear	VGF22ES25	52	52		
									3"	125	150 psi @ 240 F	15 psi (2-position)	Equal %	V5011A1767	24	24	42	42								
	125														175 psi @ 130 F	125 psig / 353 F	Linear	VGF21ES30	26	26						
120		175 psi @ 130 F	125 psig / 353 F	Linear	VGF21LS30	26	26																			
	2 1/2"					70	Pressure Balanced Standard	250	175 psi @ 130 F	125 psig / 353 F	Equal %	Stem down to close	VGF21EP25	175	175	175	175									
3"		115	Pressure Balanced Standard	125	175 psi @ 130 F									125 psig / 353 F	Equal %	VGF21ES25			77	77						
																	120	Pressure Balanced Standard	250	400 psi @ 130 F	Linear	VGF21LP25	175	175	175	175
																							125	Standard	250	400 psi @ 130 F
3"		120	Standard	250	400 psi @ 130 F									125 psig / 353 F	Equal %	Stem down to close	VGF22ES25			77	77					
																		115	Pressure Balanced Standard	125	175 psi @ 130 F	125 psig / 353 F	Linear	VGF21EP30	175	175
	125					Standard	250	400 psi @ 130 F	Linear	VGF21ES30			38												38	
											120	Standard	250					400 psi @ 130 F	125 psig / 353 F	Linear	VGF21LP30	175	175	175	175	
	2 1/2"					63	Mixing	125	150 psi @ 240 F	N / A												Constant Total	Stem up closes A-AB	V5013B1003	52	52
											70	175 psi @ 130 F	250					400 psi @ 130 F	Linear, Constant Total	Stem up closes B-AB	V5013C1001				52	52
100		Mixing	250	400 psi @ 130 F	Linear, Constant Total									Stem up closes A-AB	VGF31EM25	66	66								97	97
																120	Diverting								250	400 psi @ 130 F
3"		100	Mixing	125	150 psi @ 240 F						N / A	Equal % A-AB	Stem up closes A-AB	VGF32EM25	66			66	97	97						
															100	Diverting	250	400 psi @ 130 F	Linear, Constant Total	Stem up closes B-AB	VGF32LD25				52	52
	120					Mixing	250	400 psi @ 130 F	Linear, Constant Total	Stem up closes A-AB												V5013B1011	24	24	42	42
															120	Diverting	250	400 psi @ 130 F	Linear, Constant Total	Stem up closes B-AB	V5013C1019		24	24	42	42
	115					Mixing	250	400 psi @ 130 F	Linear, Constant Total	Stem up closes A-AB												VGF31EM30	44	44	65	65
															120	Diverting	250	400 psi @ 130 F	Linear, Constant Total	Stem up closes B-AB	VGF31LD30		26	26	65	65
120	Diverting	250	400 psi @ 130 F	Linear, Constant Total	Stem up closes A-AB	VGF32EM30	44	44	65	65																
							120	Diverting	250	400 psi @ 130 F	Linear, Constant Total	Stem up closes B-AB	VGF32LD30	26	26	65	65									

Flanged Globe Valves 2½- 3"

With Direct Coupled Spring Return Actuators and Valve Linkage

Common Features

- ANSI body class 125 or 250
- Close-off pressure = Maximum differential pressure
- Maximum static water pressure: Up to 400 psi
- Maximum steam pressure (VGF, 2-pos or modulating): 100 psi
- Maximum steam pressure (V5011, 2-pos): 15 psi
- Stem travel: 0.75"
- Rangeability: 50:1
- Body material: Cast iron
- Body trim: Stainless steel stem, brass seat (V5011/13), stainless steel (VGF)

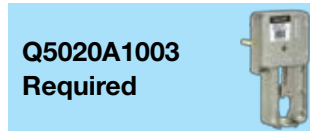

Actuator Features		Fail Safe		
Actuator O.S. Number		MS7510A2008 MS7510A2206 MS7510H2209	MS8110A1008	MS4110A1002
Power Supply	Voltage	24 Vac	24 Vac	100-250 Vac
	Frequency	50 / 60 Hz	50 / 60 Hz	60 Hz
	Power	14 VA	30 VA	45VA
Actuator Torque	(lb.-in.)	88	88	88
Linkage Stem Force	(lbs.)	117	117	117
Control	(0)2-10 Vdc	•		
	4-20 mA (external 500 Ohm Resistor)	•		
	Floating	•		
	Two-Position SPDT	•		
	Two-Position SPST	•	•	•
Fail Safe Action		Configurable Open/Closed	Configurable Open/Closed	Configurable Open/Closed
Normal Position (no signal) (field configurable)		Stem Up/Down	Stem Up/Down	Stem Up/Down
Actuator Stroke	(degrees)	95°	95°	95°
Timing	(seconds)	90	90	90
High Temperature Kit	Steam Application	43196000-001	43196000-001	43196000-001
Aux Switch	SPDT Built In	0 / 2 / 2	0 / 2	0 / 2
	1 x SPDT Add-On			
	2 x SPDT Add-On	SW2-US	SW2-US	SW2-US
Feedback	(0)2-10 Vdc Built In	•		
	500 Ohm Add-On			
	2 kOhm Add-On			

2-Way Water & Steam Valves
ANSI Class III (< 0.05% Cv) Seat Leakage

2-Way Water & Steam Valves
ANSI Class IV (< 0.01% Cv) Seat Leakage

3-Way Water Valves

Valve Size (inches)	Cv	Valve Type	ANSI Class	Max Static Water Pressure	Max Steam Pressure / Temperature	Flow Characteristic	Valve Action	Valve OS Number	Close-off Pressure, psid			
2 1/2"	63	Standard	125	150 psi @ 240 F	15 psi (2-position)	Equal %	Stem down to close	V5011A1734	27	27	27	
				175 psi @ 130 F	125 psig / 353 F	Equal %		VG21ES25	33	33	33	
				175 psi @ 130 F		Linear		VG21LS25	33	33	33	
	100		400 psi @ 130 F	15 psi (2-position)	Equal %	VG22ES25		33	33	33		
			115		150 psi @ 240 F	Equal %		V5011A1767	11	11	11	
					175 psi @ 130 F	Equal %		VG21ES30	15	15	15	
125	175 psi @ 130 F	125 psig / 353 F	Linear	VG21LS30	15	15	15					
	120		400 psi @ 130 F	Equal %	VG22ES30	15	15	15				
			250	125 psig / 353 F	Equal %	VG21EP25	100	100	100			
Standard	VG21ES25											
Pressure Balanced	VG21LP25	100			100	100						
3"	115	Standard	125	175 psi @ 130 F	125 psig / 353 F	Equal %	Stem down to close	VG21LS25				
				175 psi @ 130 F		Equal %		VG22ES25				
				175 psi @ 130 F		Linear		VG21EP30				
	120	Pressure Balanced	Equal %	VG21ES30								
		Standard	Equal %	VG21LP30								
		Pressure Balanced	Linear	VG21LS30								
2 1/2"	63	Mixing	125	150 psi @ 240 F	N / A	Constant Total	Stem up closes A-AB	V5013B1003	27	27	27	
				150 psi @ 240 F		Constant Total		V5013C1001	27	27	27	
				175 psi @ 130 F		Equal % A-AB		VG31EM25	43	43	43	
	70		175 psi @ 130 F	Linear, Constant Total		Stem up closes B-AB		VG31LD25	33	33	33	
			400 psi @ 130 F	Equal % A-AB		Stem up closes A-AB		VG32EM25	43	43	43	
			400 psi @ 130 F	Linear, Constant Total		Stem up closes B-AB		VG32LD25	33	33	33	
3"	100	Mixing	125	150 psi @ 240 F	N / A	Constant Total	Stem up closes A-AB	V5013B1011	11	11	11	
				150 psi @ 240 F		Constant Total		Stem up closes B-AB	V5013C1019	11	11	11
				175 psi @ 130 F		Equal % A-AB		Stem up closes A-AB	VG31EM30	28	28	28
	120		175 psi @ 130 F	Linear, Constant Total		Stem up closes B-AB		VG31LD30	15	15	15	
			400 psi @ 130 F	Equal % A-AB		Stem up closes A-AB		VG32EM30	28	28	28	
			400 psi @ 130 F	Linear, Constant Total		Stem up closes B-AB		VG32LD30	15	15	15	

Flanged Globe Valves 2½- 3"

With Direct Coupled Spring Return Actuators and Valve Linkage

**Q5020A1003
Required**



Actuator Features		Fail Safe		
Actuator O.S. Number		MS7520A2007 MS7520A2205 MS7520M2208	MS8120A1007	MS4120A1001
Power Supply	Voltage	24 Vac	24 Vac	100-250 Vac
	Frequency	50 / 60 Hz	50 / 60 Hz	60 Hz
	Power	16 VA	40 VA	60 VA
Actuator Torque (lb.-in.)		175	175	175
Linkage Stem Force (lbs.)		234	234	234
Control	(0)2-10 Vdc	•		
	4-20 mA (external 500 Ohm Resistor)	•		
	Floating	•		
	Two-Position SPDT	•		
	Two-Position SPST	•	•	•
Fail Safe Action		Configurable Open/Closed	Configurable Open/Closed	Configurable Open/Closed
Normal Position (no signal) (field configurable)		Stem Up/Down	Stem Up/Down	Stem Up/Down
Actuator Stroke (degrees)		95°	95°	95°
Timing (seconds)		90	90	90
High Temperature Kit Steam Application		43196000-001	43196000-001	43196000-001
Aux Switch	SPDT Built In	0 / 2 / 2	0 / 2	0 / 2
	1 x SPDT Add-On			
	2 x SPDT Add-On	SW2-US	SW2-US	SW2-US
Feedback	(0)2-10 Vdc Built In	•		
	500 Ohm Add-On			
	2 kOhm Add-On			

Valve Size (inches)	Cv	Valve Type	ANSI Class	Max Static Water Pressure	Max Steam Pressure / Temperature	Flow Characteristic	Valve Action	Valve OS Number	Close-off Pressure, psid										
2 1/2"	63	Standard	125	150 psi @ 240 F	15 psi (2-position)	Equal %	Stem down to close	V5011A1734	56	56	56								
								VG21ES25	71	71	71								
								VG21LS25	71	71	71								
								VG22ES25	71	71	71								
								V5011A1767	25	25	25								
								VG21ES30	35	35	35								
	3"	100	Standard	125	150 psi @ 240 F	15 psi (2-position)	Equal %	Stem down to close	VG21LS30	35	35	35							
									VG22ES30	35	35	35							
									70	Pressure Balanced	125	175 psi @ 130 F	125 psig / 353 F	Equal %	Stem down to close	VG21EP25	175	175	175
																VG21ES25			
																VG21LP25	175	175	175
																VG21LS25			
VG22ES25																			
VG21EP30	175	175	175																
3"	115	Standard	125	175 psi @ 130 F	125 psig / 353 F	Equal %	Stem down to close	VG21ES30											
								VG21LP30	175	175	175								
								VG21LS30											
								VG22ES30											
								2 1/2"	63	Mixing	125	150 psi @ 240 F	N / A	Constant Total	Stem up closes A-AB	V5013B1003	56	56	56
																V5013C1001	56	56	56
VG31EM25	89	89	89																
VG31LD25	71	71	71																
VG32EM25	89	89	89																
VG32LD25	71	71	71																
3"	100	Diverting	125	150 psi @ 240 F	N / A	Constant Total	Stem up closes A-AB		V5013B1011	25	25	25							
									V5013C1019	25	25	25							
									VG31EM30	59	59	59							
									VG31LD30	35	35	35							
									VG32EM30	59	59	59							
									VG32LD30	35	35	35							

VALVE SELECTION

Threaded and Flanged Globe Valves 2"- 3"

With Tandem Direct Coupled Actuators and Valve Linkage

Common Features

- Stem travel: 0.75"
- Rangeability: 50:1
- Body material: Bronze (V5011/13N), Cast iron
- Seat Material: Bronze (V5011/13), Stainless Steel (VGF2), Cast Iron (VGF3)
- Stem Material: Stainless Steel

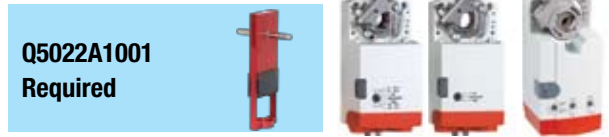

Actuator Features		Non-fail Safe			
		MN7220A2007	MN6120A1002	MN72342008	MN6134A1003
Actuator O.S. Number (Two required per linkage/valve)					
Power Supply	Voltage	24 Vac	24 Vac	24 Vac	24 Vac
	Frequency	60 Hz	60 Hz	60 Hz	60 Hz
	Power	6 VA	6 VA	9 VA	9 VA
Actuator Torque (lb.-in.)		175	175	300	300
Linkage Stem Force, Two Actuators (lbs.)		655	655	1115	1115
Control	(0)2-10 Vdc	•		•	
	4-20 mA (external 500 Ohm Resistor)	•		•	
	Floating	•	•	•	•
	Two-Position SPDT	•	•	•	•
Two-Position SPST		•	•	•	
Fail Safe Action		Stay in Place	Stay in Place	Stay in Place	Stay in Place
Normal Position (no signal) (field configurable)		Stem Up/Down	Stem Up/Down	Stem Up/Down	Stem Up/Down
Actuator Stroke (inches)		0.75	0.75	0.75	0.75
Timing (seconds)		95	95	95	95
Aux Switch	2 x SPDT Add-On	SW2-US	SW2-US	SW2-US	SW2-US
	2 x SPDT Built In				
Feedback		(0)2-10 Vdc Built In	•		•

2-Way Water & Steam Valves
ANSI Class III (< 0.05% Cv) Seat Leakage

2-Way Water & Steam Valves
ANSI Class IV (< 0.01% Cv) Seat Leakage

3-Way Water Valves

Valve Size (inches)	Pipe Fitting	Cv	Valve Type	ANSI Class	Max Static Water Pressure	Max Steam Pressure / Temperature	Flow Characteristic	Valve Action	Valve OS Number	Close-off Pressure, psid							
2"	f NPT	47	Standard	150	217 psi @ 248 F	15 psi (2-position)	Equal %	Stem down to close	V5011N1099	162	162	240	240				
2"	f NPT	47							150	217 psi @ 248 F	100 psig / 337 F	Equal %	V5011N2097	100	100	100	100
2 1/2"	Flanged	63							125	150 psi @ 240 F	15 psi (2-position)	Equal %	V5011A1734	130	130	225	225
									150	250 psi @ 100F	15 psi (2-position)	Equal %	V5011F1105	130	130	225	225
	f NPT	63							150	250 psi @ 100F	100 psig / 337 F	Linear	V5011G1111	100	100	100	100
									125	175 psi @ 130 F		Equal %	VGF21ES25	110	110	190	190
3"	Flanged	70		125	175 psi @ 130 F	125 psig / 353 F	Linear		VGF21LS25	110	110	190	190				
				250	400 psi @ 130 F		Equal %		VGF22ES25	110	110	190	190				
				125	150 psi @ 250 F	15 psi (2-position)	Equal %		V5011A1767	66	66	115	115				
	f NPT	100		150	250 psi @ 100F	15 psi (2-position)	Equal %		V5011F1113	65	65	115	115				
				150	250 psi @ 100F	100 psig / 337 F	Linear		V5011G1129	65	65	100	100				
				125	175 psi @ 130 F		Equal %		VGF21ES30	55	55	94	94				
3"	Flanged	120	125	175 psi @ 130 F	125 psig / 353 F	Linear	VGF21LS30	55	55	94	94						
			250	400 psi @ 130 F		Equal %	VGF22ES30	55	55	94	94						
			2 1/2"	Flanged	70	Pressure Balanced	125	175 psi @ 130 F	125 psig / 353 F	Stem down to close	VGF21EP25	175*	175*	175*	175*		
						Standard					VGF21ES25	74	74	152	152		
						Pressure Balanced					VGF21LP25	175*	175*	175*	175*		
					Standard	VGF21LS25					74	74	152	152			
3"	Flanged	115			Pressure Balanced	115					175 psi @ 130 F	175*	175*	175*	175*		
					Standard	120					175 psi @ 130 F	Equal %	VGF21EP30	36	36	75	75
			Pressure Balanced	115	175 psi @ 130 F	Linear	VGF21ES30	36	36	75	75						
3"	Flanged	120	Standard	120	175 psi @ 130 F	Linear	VGF21LP30	175*	175*	175*	175*						
			Standard	120	175 psi @ 130 F	Equal %	VGF21ES30	36	36	75	75						
			Standard	120	175 psi @ 130 F	Linear	VGF21LS30	36	36	75	75						
			Standard	120	175 psi @ 130 F	Equal %	VGF22ES30	36	36	75	75						
			2 1/2"	f NPT	47	Mixing	150	217 psi @ 248 F	N / A	Stem up closes A-AB	V5013N1097	162	162	240	240		
						Mixing					150 psi @ 240 F	Constant Total	V5013B1003	130	130	225	225
Diverting	150 psi @ 240 F	Constant Total				V5013C1001					130	130	225	225			
Mixing	175 psi @ 130 F	Linear B-AB / Equal % A-AB				VGF31EM50					141	141	240	240			
Diverting	175 psi @ 130 F	Linear, Constant Total				VGF31LD50					110	110	190	190			
Mixing	400 psi @ 130 F	Linear B-AB / Equal % A-AB				VGF32EM50					141	141	240	240			
3"	Flanged	100		Mixing	150 psi @ 240 F	Constant Total	V5013B1011	65	65	115	115						
				Diverting	150 psi @ 240 F	Constant Total	V5013C1019	65	65	115	115						
				Mixing	175 psi @ 130 F	Linear B-AB / Equal % A-AB	VGF31EM60	94	94	160	160						
				Diverting	175 psi @ 130 F	Linear, Constant Total	VGF31LD60	110	110	190	190						
				Mixing	250	400 psi @ 130 F	Linear B-AB / Equal % A-AB	VGF32EM60	94	94	160	160					
				Diverting	250	400 psi @ 130 F	Linear, Constant Total	VGF32LD60	110	110	190	190					

*Only requires single actuator

** For high pressure steam-rated valves, close-off is the lesser of Maximum Steam Pressure or water close-off rating

Threaded and Flanged Globe Valves 2"- 3"

With Tandem Direct Coupled Actuators and Valve Linkage



**Q5022A1001
Required*****



Actuator Features	Fail Safe		
Actuator O.S. Number (Two required per linkage/valve)	MS7520A2007	MS8120A1007	MSA120A1001
	MS7520A2205		
Power Supply	Voltage	24 Vac	24 Vac
	Frequency	60 Hz	60 Hz
	Power	16 VA	40 VA
Actuator Torque	(lb.-in.)	175	175
Linkage Stem Force, Two Actuators	(lbs.)	655	655
Control	(0)2-10 Vdc	•	
	4-20 mA (external 500 Ohm Resistor)	•	
	Floating	•	
	Two-Position SPDT	•	
	Two-Position SPST	•	•
Fail Safe Action	Configurable Open/Closed	Configurable Open/Closed	Configurable Open/Closed
	Normal Position (no signal) (field configurable)	Stem Up/Down	Stem Up/Down
	Actuator Stroke (inches)	0.75	0.75
Timing (seconds)	90	90	90
Aux Switch	2 x SPDT Add-On	SW2-US	SW2-US
	2 x SPDT Built In	0 / 2	
Feedback	(0)2-10 Vdc Built In	•	

VALVE SELECTION

Valve Size (inches)	Pipe Fitting	Cv	Valve Type	ANSI Class	Max Static Water Pressure	Max Steam Pressure / Temperature	Flow Characteristic	Valve Action	Valve OS Number	Close-off Pressure, psid												
2 1/2"	f NPT	47	Standard	150	217 psi @ 248 F	15 psi (2-position)	Equal %	Stem down to close	V5011N1099	162	162	162										
					217 psi @ 248 F				100 psig / 337 F	Equal %	V5011N2097	100	100	20								
	Flanged	63			125				150 psi @ 240 F	15 psi (2-position)	Equal %	V5011A1734	130	130	130							
					150				250 psi @ 100F	15 psi (2-position)	Equal %	V5011F1105	130	130	130							
	f NPT	63			150				250 psi @ 100F	100 psig / 337 F	Linear	V5011G1111	100	100	100							
					125				175 psi @ 130 F		Equal %	VGF21ES25	110	110	110							
	Flanged	70		125	175 psi @ 130 F	125 psig / 353 F	Linear		VGF21LS25	110	110	110										
				250	400 psi @ 130 F		Equal %		VGF22ES25	110	110	110										
	3"	Flanged		100	125	150 psi @ 250 F	15 psi (2-position)		Equal %	V5011A1767	66	66	66									
					150	250 psi @ 100F	15 psi (2-position)		Equal %	V5011F1113	65	65	65									
		f NPT		100	150	250 psi @ 100F	100 psig / 337 F		Linear	V5011G1129	65	65	65									
					125	175 psi @ 130 F			Equal %	VGF21ES30	55	55	55									
Flanged		120	125	175 psi @ 130 F	125 psig / 353 F	Linear	VGF21LS30	55	55	55												
			250	400 psi @ 130 F		Equal %	VGF22ES30	55	55	55												
2 1/2"	Flanged	70	Pressure Balanced	125	175 psi @ 130 F	125 psig / 353 F	Equal %	Stem down to close	VGF21EP25	175*	175*	175*										
									Standard	VGF21ES25	74	74	74									
										Pressure Balanced	VGF21LP25	175*	175*	175*								
									Standard		VGF21LS25	74	74	74								
										Standard	250	400 psi @ 130 F		Equal %	VGF22ES25	74	74	74				
									3"		Flanged	115	Pressure Balanced	125	175 psi @ 130 F	125 psig / 353 F	Equal %	VGF21EP30	175*	175*	175*	
			Standard	VGF21ES30	36	36	36															
				Pressure Balanced	VGF21LP30	175*	175*			175*												
			Standard		VGF21LS30	36	36			36												
				Standard	120	Standard	250			400 psi @ 130 F									Equal %	VGF22ES30	36	36
			2 1/2"		Flanged	70	Mixing			150								217 psi @ 248 F	N / A	Linear B-AB / Equal % A-AB	Stem up closes A-AB	V5013N1097
				Diverting					150 psi @ 240 F		Constant Total	V5013B1003	130	130	130							
Mixing	150 psi @ 240 F	Stem up closes B-AB						V5013C1001	130		130	130										
	Diverting	125		175 psi @ 130 F				Linear B-AB / Equal % A-AB	VGF31EM50		141	141	141									
Mixing		70		175 psi @ 130 F				Linear, Constant Total	VGF31LD50		110	110	110									
	Diverting	250		400 psi @ 130 F				Linear B-AB / Equal % A-AB	VGF32EM50		141	141	141									
3"		Flanged		100			Mixing	125	150 psi @ 240 F	N / A	Linear, Constant Total	Stem up closes B-AB	VGF32LD50	110	110	110						
	Diverting											150 psi @ 240 F	Constant Total	V5013B1011	65	65	65					
												Mixing	150 psi @ 240 F	Stem up closes A-AB	V5013C1019	65	65	65				
	Diverting												115	175 psi @ 130 F	Linear B-AB / Equal % A-AB	VGF31EM60	94	94	94			
												Mixing	120	175 psi @ 130 F	Linear, Constant Total	VGF31LD60	110	110	110			
	Diverting												115	Mixing	250	400 psi @ 130 F		Linear B-AB / Equal % A-AB	Stem up closes A-AB	VGF32EM60		94
Diverting		120	Diverting	250	400 psi @ 130 F		Linear, Constant Total	Stem up closes B-AB	VGF32LD60	110	110	110										

*Only requires single actuator
 ** For high pressure steam-rated valves, close-off is the lesser of Maximum Steam Pressure or water close-off rating
 ***Q5022A linkage compatible with VGF valves with 1/4-28UNF stem thread (Manufactured after June, 2005)

Flanged Globe Valves 2½- 3"

With Dedicated Valve Actuators

Common Features

- ANSI body class 125 or 250
- Close-off pressure = Maximum differential pressure
- Maximum static water pressure: Up to 400 psi
- Maximum steam pressure (VGF, 2-pos or modulating): 100 psi
- Maximum steam pressure (V5011, 2-pos): 15 psi
- Stem travel: 0.75"
- Rangeability: 50:1
- Body material: Cast iron
- Body trim: Stainless steel stem, brass seat (V5011/13), stainless steel (VGF)



Actuator Features		Non-fail Safe			
Actuator O.S. Number		ML7984A4009**	ML6984A4000**	ML7420A3055	ML7420A3063
Power Supply	Voltage	24 Vac / 28 Vdc	24 Vac / 28 Vdc	24 Vac	24 Vac
	Frequency	0 / 50 / 60 Hz	0 / 50 / 60 Hz	50 / 60 Hz	50 / 60 Hz
	Power	12 VA	12 VA	7 VA	7 VA
Actuator Torque	(lb.-in.)	160	160	135	135
Control	(0)2-10 Vdc	•		•	•
	4-20 mA (external 500 Ohm Resistor)	Built-in		•	•
	Floating		•		
	Two-Position SPDT		•		
	Two-Position SPST				
	135 Ohm	•			
Fail Safe Action		Stay in place	Stay in place	Stay in place	Stay in place
Normal Position (no signal) (field configurable)		Stem Up	Stem Up	Stem Up	Stem Up
Actuator Stroke	(inches)	0.5 - 1 self adj	0.5 - 1 self adj	0.75	0.75
Timing	(seconds at 0.75" stroke)	63	63	60	30
High Temperature Kit	Steam Application			43196000-001	43196000-001
Aux Switch	1 x SPDT Add-On	272630D	272630D		
	2 x SPDT Add-On			43191680-105	43191680-105
Feedback	2-10 Vdc Built In			•	•
	2-10 Vdc Add-On	272630D	272630D		
	220 Ohm Add-On				
	10 kOhm Add-On				

2-Way Water & Steam Valves
ANSI Class III (< 0.05% Cv) Seat Leakage

2-Way Water & Steam Valves
ANSI Class IV (< 0.01% Cv) Seat Leakage

Valve Size (inches)	Cv	Valve Type	ANSI Class	Max Static Water Pressure	Max Steam Pressure / Temperature	Flow Characteristic	Valve Action	Valve OS Number	Close-off Pressure, psid								
2 1/2"	63	Standard	125	150 psi @ 240 F	15 psi (2-position)	Equal %	Stem down to close	V5011A1734	33	33	28	28					
								VGF21ES25	27*	27*	23	23					
								VGF21LS25	27*	27*	23	23					
	70							250	400 psi @ 130 F	125 psig / 353 F	Equal %	Linear	VGF22ES25	27*	27*	23	23
													V5011A1767	19	19	16	16
													VGF21ES30	13*	13*	11	11
3"	100	125	175 psi @ 130 F	125 psig / 353 F	Equal %	Linear	VGF21LS30	13*	13*	11	11						
							VGF22ES30	13*	13*	11	11						
							V5011A1734	33	33	28	28						
	2 1/2"	70	Pressure Balanced	125	175 psi @ 130 F	125 psig / 353 F	Equal %	Stem down to close	VGF21EP25	175	175	175	175				
			Standard						VGF21ES25								
			Pressure Balanced						VGF21LP25	175	175	175	175				
Standard			VGF21LS25														
Standard			VGF22ES25														
Standard			VGF21EP30						175	175	175	175					
3"	115	120	175 psi @ 130 F	125 psig / 353 F	Equal %	Linear	VGF21ES30	13*	13*	11	11						
							VGF21LP30	175	175	175	175						
							VGF21LS30	13*	13*	11	11						
	2 1/2"	70	Mixing	125	150 psi @ 240 F	N/A	Constant Total	Stem up closes A-AB	V5013B1003	27	27	23	23				
			Diverting						V5013C1001	25	25	21	21				
			Mixing						VGF31EM25	34	34	29	29				
Diverting			VGF31LD25						27	27	23	23					
Mixing			VGF32EM25						34	34	29	29					
Diverting			VGF32LD25						27	27	23	23					
3"	100	120	175 psi @ 130 F	N/A	Constant Total	Stem up closes A-AB	Stem up closes A-AB	V5013B1011	13	13	11	11					
								Diverting	V5013C1019	17	17	14	14				
								Mixing	VGF31EM30	22	22	19	19				
	115	120	175 psi @ 130 F	N/A	Linear, Constant Total	Stem up closes B-AB	Stem up closes B-AB	VGF31LD30	13	13	11	11					
								Mixing	VGF32EM30	22	22	19	19				
								Diverting	VGF32LD30	13	13	11	11				

*Requires 272629A adapter kit to provide upper stop for actuator torque switch

Flanged Globe Valves 2½- 3"

With Dedicated Valve Actuators



VALVE SELECTION

Actuator Features		Non-fail Safe			
Actuator O.S. Number		ML6420A3049	ML6420A3056	ML7421A1032	ML6421A1017
Power Supply	Voltage	24 Vac	24 Vac	24 Vac	24 Vac
	Frequency	50 / 60 Hz	50 / 60 Hz	50 / 60 Hz	50 / 60 Hz
	Power	6 VA	6 VA	12 VA	11 VA
Actuator Torque	(lb.-in.)	135	135	404	404
Control	(0)2-10 Vdc			•	
	4-20 mA (external 500 Ohm Resistor)			•	
	Floating	•	•		•
	Two-Position SPDT	•	•		•
	Two-Position SPST				
	135 Ohm				
Fail Safe Action		Stay in place	Stay in place	Stay in place	Stay in place
Normal Position (no signal)	(field configurable)	Stem Up	Stem Up	Stem Up	Stem Up
Actuator Stroke	(inches)	0.75	0.75	0.75	0.75
Timing	(seconds at 0.75" stroke)	60	30	90	90
High Temperature Kit	Steam Application	43196000-001	43196000-001	43196000-001	43196000-001
Aux Switch	1 x SPDT Add-On				
	2 x SPDT Add-On	43191680-105	43191680-105	43191680-102	43191680-102
Feedback	2-10 Vdc Built In			•	
	2-10 Vdc Add-On				
	220 Ohm Add-On	43191679-111	43191679-111		43191679-101
	10 kOhm Add-On	43191679-112	43191679-111		

Valve Size (inches)	Cv	Valve Type	ANSI Class	Max Static Water Pressure	Max Steam Pressure / Temperature	Flow Characteristic	Valve Action	Valve OS Number	Close-off Pressure, psid				
2 1/2"	63	Standard	125	150 psi @ 240 F	15 psi (2-position)	Equal %	Stem down to close	V5011A1734	28	28	77	77	
				175 psi @ 130 F		Equal %		VGf21ES25	23	23			
				175 psi @ 130 F		Linear		VGf21LS25	23	23			
	70			250	400 psi @ 130 F	15 psi (2-position)		Equal %	VGf22ES25	23	23		
				125	150 psi @ 240 F			Equal %	V5011A1767	16	16	53	53
				115	175 psi @ 130 F			Equal %	VGf21ES30	11	11		
3"	125	175 psi @ 130 F	125	175 psi @ 130 F	125 psig / 353 F	Linear	VGf21LS30	11	11				
	120	400 psi @ 130 F		Equal %		VGf22ES30	11	11					
	120	400 psi @ 130 F		Equal %									
2 1/2"	70	Pressure Balanced	125	175 psi @ 130 F	125 psig / 353 F	Equal %	Stem down to close	VGf21EP25	175	175	175	175	
		Standard				Equal %		VGf21ES25			69	69	
		Pressure Balanced				Linear		VGf21LP25	175	175	175	175	
		Standard				Linear		VGf21LS25			69	69	
		Standard				Equal %		VGf22ES25			69	69	
		Standard				Equal %		VGf21EP30	175	175	175	175	
	3"	115	Pressure Balanced	125		175 psi @ 130 F		Equal %	VGf21ES30			34	34
		120	Standard					Linear	VGf21LP30	175	175	175	175
		120	Pressure Balanced					Linear	VGf21LS30			34	34
		120	Standard					Equal %	VGf22ES30			34	34
		120	Standard					Equal %					
		120	Standard					Equal %					
2 1/2"	63	Mixing	125	150 psi @ 240 F	N/A	Constant Total	Stem up closes A-AB	V5013B1003	23	23	77	77	
		Diverting				Constant Total		V5013C1001	21	21	77	77	
		Mixing				Equal % A-AB		VGf31EM25	29	29	87	87	
		Diverting				Linear, Constant Total		VGf31LD25	23	23	69	69	
		Mixing				Equal % A-AB		VGf32EM25	29	29	87	87	
		Diverting				Linear, Constant Total		VGf32LD25	23	23	69	69	
	70	Mixing	250	400 psi @ 130 F		Constant Total		Stem up closes A-AB	V5013B1011	11	11	53	53
		Diverting				Constant Total			V5013C1019	14	14	53	53
		Mixing				Equal % A-AB			VGf31EM30	19	19	58	58
		Diverting				Linear, Constant Total			VGf31LD30	11	11	34	34
		Mixing				Equal % A-AB			VGf32EM30	19	19	58	58
		Diverting				Linear, Constant Total			VGf32LD30	11	11	34	34
3"	100	Mixing	125	150 psi @ 240 F	N/A	Constant Total	Stem up closes B-AB		V5013B1011	11	11	53	53
	100	Diverting				Constant Total			V5013C1019	14	14	53	53
	120	Mixing				Equal % A-AB			VGf31EM30	19	19	58	58
	120	Diverting				Linear, Constant Total			VGf31LD30	11	11	34	34
	115	Mixing				Equal % A-AB			VGf32EM30	19	19	58	58
	120	Diverting				Linear, Constant Total			VGf32LD30	11	11	34	34

Flanged Globe Valves 2½- 3"

With Dedicated Valve Actuators

Common Features

- ANSI body class 125 or 250
- Close-off pressure = Maximum differential pressure
- Maximum static water pressure: Up to 400 psi
- Maximum steam pressure (VGF, 2-pos or modulating): 100 psi
- Maximum steam pressure (V5011, 2-pos): 15 psi
- Stem travel: 0.75"
- Rangeability: 50:1
- Body material: Cast iron
- Body trim: Stainless steel stem, brass seat (V5011/13), stainless steel (VGF)



Actuator Features		Fail Safe			
Actuator O.S. Number		ML7425A3013	ML7425B3012	ML6425A3022	ML6425B3013
Power Supply	Voltage	24 Vac	24 Vac	24 Vac	24 Vac
	Frequency	50 / 60 Hz	50 / 60 Hz	50 / 60 Hz	50 / 60 Hz
Power		12 VA	12 VA	11 VA	11 VA
Actuator Torque (lb.-in.)		135	135	135	135
Control (0)2-10 Vdc		•	•		
4-20 mA (external 500 Ohm Resistor)		•	•		
Floating				•	•
Two-Position SPDT				•	•
Two-Position SPST				•	•
135 Ohm					
Fail Safe Action		Stem Down (2-way N.C.)	Stem Up (2-way N.O.)	Stem Down (2-way N.C.)	Stem Up (2-way N.O.)
Normal Position (no signal) (field configurable)		Stem Up	Stem Up	Stem Up	Stem Up
Actuator Stroke (inches)		0.75	0.75	0.75	0.75
Timing (seconds at 0.75" stroke)		90	90	90	90
High Temperature Kit Steam Application		43196000-001	43196000-001	43196000-001	43196000-001
Aux Switch 1 x SPDT Add-On					
2 x SPDT Add-On		43191680-105	43191680-105	43191680-105	43191680-105
Feedback 2-10 Vdc Built In		•	•		
2-10 Vdc Add-On					
220 Ohm Add-On				43191679-111	
10 kOhm Add-On				43191679-112	

2-Way Water & Steam Valves
ANSI Class III (< 0.05% Cv) Seat Leakage

2-Way Water & Steam Valves
ANSI Class IV (< 0.01% Cv) Seat Leakage

3-Way Water Valves

Valve Size (inches)	Cv	Valve Type	ANSI Class	Max Static Water Pressure	Max Steam Pressure / Temperature	Flow Characteristic	Valve Action	Valve OS Number	Close-off Pressure, psid							
2 1/2"	63	Standard	125	150 psi @ 240 F	15 psi (2-position)	Equal %	Stem down to close	V5011A1734	28	28	28	28				
				175 psi @ 130 F				VG21ES25	23	23	23	23				
				175 psi @ 130 F				VG21LS25	23	23	23	23				
	100		250	400 psi @ 130 F	15 psi (2-position)	Equal %		VG22ES25	23	23	23	23				
			125	150 psi @ 240 F				V5011A1767	16	16	16	16				
				175 psi @ 130 F				VG21ES30	11	11	11	11				
125	250	175 psi @ 130 F	125 psig / 353 F	Linear	VG21LS30	11	11	11	11							
		400 psi @ 130 F			VG22ES30	11	11	11	11							
2 1/2"	70	Pressure Balanced	125	175 psi @ 130 F	125 psig / 353 F	Equal %	Stem down to close	VG21EP25	175	175	175	175				
				Standard				VG21ES25								
		Pressure Balanced		250		400 psi @ 130 F		VG21LP25	175	175	175	175				
						Standard		VG21LS25								
		115		Pressure Balanced		125		175 psi @ 130 F	125 psig / 353 F	Equal %	VG22ES25	23	23	23	23	
	Standard		150 psi @ 240 F					VG21EP30			175	175	175	175		
			175 psi @ 130 F					VG21ES30								
	120	Standard	250	400 psi @ 130 F		Linear		Equal %	VG21LP30	175	175	175	175			
				175 psi @ 130 F					VG21LS30							
	2 1/2"	63	Mixing	125		150 psi @ 240 F		N / A	Constant Total	Stem up closes A-AB	V5013B1003	21	21	21	21	
Diverting					150 psi @ 240 F	Constant Total	Stem up closes B-AB				V5013C1001	21	21	21	21	
					175 psi @ 130 F	Equal % A-AB	Stem up closes A-AB				VG21EM25	29	29	29	29	
70			Diverting		250	175 psi @ 130 F	Linear, Constant Total		Stem up closes B-AB		VG21LD25	23	23	23	23	
						400 psi @ 130 F	Equal % A-AB		Stem up closes A-AB		VG22EM25	29	29	29	29	
						400 psi @ 130 F	Linear, Constant Total		Stem up closes B-AB		VG22LD25	23	23	23	23	
100		Mixing	125	150 psi @ 240 F	N / A	Constant Total	Stem up closes A-AB		V5013B1011	14	14	14	14			
				Diverting					150 psi @ 240 F	Constant Total	Stem up closes B-AB	V5013C1019	14	14	14	14
									175 psi @ 130 F	Equal % A-AB	Stem up closes A-AB	VG21EM30	19	19	19	19
		120		Diverting		250			175 psi @ 130 F	Linear, Constant Total	Stem up closes B-AB	VG21LD30	11	11	11	11
									400 psi @ 130 F	Equal % A-AB	Stem up closes A-AB	VG22EM30	19	19	19	19
									400 psi @ 130 F	Linear, Constant Total	Stem up closes B-AB	VG22LD30	11	11	11	11

Flanged Globe Valves 4"- 6"

With Tandem Direct Coupled Actuators and Valve Linkage

Common Features

- Stem travel: 1.5"
- Rangeability: 50:1
- Body material: Cast iron
- Seat Material: Bronze (V5011/13), Stainless Steel (VGF)
- Stem Material: Stainless Steel
- Normal position field configurable to stem up or stem down



Actuator Features		Non-fail Safe			
Actuator O.S. Number (Two Actuators per valve/linkage)		MNT220A2007	MNG120A1002	MNT2342008	MNG134A1003
Power Supply	Voltage	24 Vac	24 Vac	24 Vac	24 Vac
	Frequency	60 Hz	60 Hz	60 Hz	60 Hz
Actuator Torque	Power	6 VA	6 VA	9 VA	9 VA
	(lb.-in.)	175	175	300	300
Linkage Stem Force, Two Actuators	(lbs.)	325	325	555	555
Control	(0)2-10 Vdc	•		•	
	4-20 mA (external 500 Ohm Resistor)	•		•	
	Floating	•	•	•	•
	Two-Position SPDT	•	•	•	•
	Two-Position SPST	•	•	•	
Fail Safe Action		Stay in Place	Stay in Place	Stay in Place	Stay in Place
Normal Position (no signal)	(field configurable)	Stem Up/Down	Stem Up/Down	Stem Up/Down	Stem Up/Down
Actuator Stroke	(inches)	1.5	1.5	1.5	1.5
Timing	(seconds)	95	95	95	95
Aux Switch	2 x SPDT Add-On	SW2-US	SW2-US	SW2-US	SW2-US
	2 x SPDT Built In				
Feedback	(0)2-10 Vdc Built In			•	

2-Way Water & Steam Valves ANSI Class III (< 0.05% Cv) Seat Leakage
 2-Way Water & Steam Valves ANSI Class IV (< 0.01% Cv) Seat Leakage
 3-Way Water Valves

Valve Size (inches)	Cv	Valve Type	ANSI Class	Max Static Water Pressure	Max Steam Pressure / Temperature	Flow Characteristic	Valve Action	Valve OS Number	Close-off Pressure, psid						
4"	160	Standard	125	150 psi @ 240 F	15 psi (2-position)	Equal %	Stem down to close	V5011A1858	20	20	34	34			
	160			150 psi @ 240 F	15 psi (2-position)	Equal %	Stem up to close	V5011B1013	20	20	34	34			
	150			175 psi @ 130 F	125 psig / 353 F	Equal %	Stem down to close	VGF21ES40	27	27	47	47			
	155			175 psi @ 130 F		Linear		VGF21LS40	27	27	47	47			
	150			400 psi @ 130 F	Equal %	VGF22ES40		27	27	47	47				
	250			150 psi @ 240 F	15 psi (2-position)	Equal %		V5011A1882	16	16	28	28			
5"	250		150 psi @ 240 F	15 psi (2-position)	Equal %	Stem up to close	V5011B1047	16	16	28	28				
	285		175 psi @ 130 F	125 psig / 353 F	Equal %	Stem down to close	VGF21ES50	11	11	18	18				
	320		175 psi @ 130 F		Linear		VGF21LS50	11	11	18	18				
	320		400 psi @ 130 F	Equal %	VGF22ES50		11	11	18	18					
	360		150 psi @ 240 F	15 psi (2-position)	Equal %		V5011A1916	11	11	19	19				
	6"		360	150 psi @ 240 F	15 psi (2-position)	Equal %	Stem up to close	V5011B1070	11	11	19	19			
365		175 psi @ 130 F	125 psig / 353 F	Equal %	Stem down to close	VGF21ES60	11	11	18	18					
370		175 psi @ 130 F		Linear		VGF21LS60	11	11	18	18					
370		400 psi @ 130 F	Equal %	VGF22ES60		11	11	18	18						
4"	150	Pressure Balanced	125	175 psi @ 130 F		125 psig / 353 F	Equal %	Stem down to close	VGF21EP40	175	175	175**	175**		
	150				Linear		VGF21LP40		175	175	175**	175**			
	5"				285		Equal %		VGF21EP50	175	175	175**	175**		
					320		Linear		VGF21LP50	175	175	175**	175**		
	6"				365		Equal %		VGF21EP60	175	175	175**	175**		
					370		Linear		VGF21LP60	175	175	175**	175**		
4"	160		Mixing	125	150 psi @ 240 F	N / A	Constant Total		Stem up closes A-AB	V5013B1029	20	20	34	34	
	160		Diverting		150 psi @ 240 F		Constant Total		Stem up closes B-AB	V5013C1027	20	20	34	34	
	150		Mixing		175 psi @ 130 F		Equal % A-AB		Stem up closes A-AB	VGF31EM40	27	27	47	47	
	160		Diverting		175 psi @ 130 F		Linear, Constant Total		Stem up closes B-AB	VGF31LD40	27	27	47	47	
	170		Mixing		250		400 psi @ 130 F		Equal % A-AB	Stem up closes A-AB	VGF32EM40	27	27	47	47
	160		Diverting		250		400 psi @ 130 F		Linear, Constant Total	Stem up closes B-AB	VGF32LD40	27	27	47	47
	5"	250	Mixing	125	150 psi @ 240 F		N / A	Constant Total	Stem up closes A-AB	V5013B1037	16	16	28	28	
		250	Diverting		150 psi @ 240 F			Constant Total	Stem up closes B-AB	V5013C1035	16	16	28	28	
		320	Mixing		175 psi @ 130 F			Equal % A-AB	Stem up closes A-AB	VGF31EM50	11	11	18	18	
		285	Diverting		175 psi @ 130 F			Linear, Constant Total	Stem up closes B-AB	VGF31LD50	11	11	18	18	
		320	Mixing		250			400 psi @ 130 F	Equal % A-AB	Stem up closes A-AB	VGF32EM50	11	11	18	18
		285	Diverting		250			400 psi @ 130 F	Linear, Constant Total	Stem up closes B-AB	VGF32LD50	11	11	18	18
6"	360	Mixing	125	150 psi @ 240 F	N / A	Constant Total		Stem up closes A-AB	V5013B1045	11	11	19	19		
	360	Diverting		150 psi @ 240 F		Constant Total		Stem up closes B-AB	V5013C1043	11	11	19	19		
	370	Mixing		175 psi @ 130 F		Equal % A-AB		Stem up closes A-AB	VGF31EM60	11	11	18	18		
	380	Diverting		175 psi @ 130 F		Linear, Constant Total		Stem up closes B-AB	VGF31LD60	11	11	18	18		
	370	Mixing		250		400 psi @ 130 F		Equal % A-AB	Stem up closes A-AB	VGF32EM60	11	11	18	18	
	380	Diverting		250		400 psi @ 130 F		Linear, Constant Total	Stem up closes B-AB	VGF32LD60	11	11	18	18	

**Only requires single actuator

***Q5022B linkage compatible with VGF valves with 7/16-20UNF stem thread (Manufactured after June, 2005)

Flanged Globe Valves 4"- 6"

With Tandem Direct Coupled Actuators and Valve Linkage

**Q5022B1009
Required*****



Actuator Features		Fail Safe		
Actuator O.S. Number (Two Actuators per valve/linkage)		MS7620A2007 MS7620A2205	MS8120A1007	MS4120A1001
Power Supply	Voltage	24 Vac	24 Vac	100-250 Vac
	Frequency	60 Hz	60 Hz	60 Hz
	Power	16 VA	40 VA	60 VA
Actuator Torque	(lb.-in.)	175	175	175
Linkage Stem Force, Two Actuators	(lbs.)	325	325	325
Control	(0)2-10 Vdc	•		
	4-20 mA (external 500 Ohm Resistor)	•		
	Floating	•		
	Two-Position SPDT	•		
	Two-Position SPST	•	•	•
Fail Safe Action		Configurable Open/Closed	Configurable Open/Closed	Configurable Open/Closed
Normal Position (no signal) (field configurable)		Stem Up/Down	Stem Up/Down	Stem Up/Down
Actuator Stroke	(inches)	1.5	1.5	1.5
Timing	(seconds)	90	90	90
Aux Switch	2 x SPDT Add-On	SW2-US	SW2-US	SW2-US
	2 x SPDT Built In	0 / 2		
Feedback	(0)2-10 Vdc Built In	•		

Valve Size (inches)	Cv	Valve Type	ANSI Class	Max Static Water Pressure	Max Steam Pressure / Temperature	Flow Characteristic	Valve Action	Valve OS Number	Close-off Pressure, psid									
4"	160	Standard	125	150 psi @ 240 F	15 psi (2-position)	Equal %	Stem down to close	V5011A1858	20	20	20							
	160			150 psi @ 240 F	15 psi (2-position)	Equal %	Stem up to close	V5011B1013	20	20	20							
	150			175 psi @ 130 F	125 psig / 353 F	Equal %	Stem down to close	VGf21ES40	27	27	27							
	155			175 psi @ 130 F		Linear		VGf21LS40	27	27	27							
	150			400 psi @ 130 F		Equal %		VGf22ES40	27	27	27							
	250		150 psi @ 240 F	15 psi (2-position)	Equal %	Stem up to close	V5011A1882	16	16	16								
	250		150 psi @ 240 F	15 psi (2-position)	Equal %		V5011B1047	16	16	16								
	285		175 psi @ 130 F	125 psig / 353 F	Equal %		VGf21ES50	11	11	11								
	320		175 psi @ 130 F		Linear		VGf21LS50	11	11	11								
	320		400 psi @ 130 F		Equal %		VGf22ES50	11	11	11								
6"	360	Standard	125	150 psi @ 240 F	15 psi (2-position)	Equal %	Stem up to close	V5011A1916	11	11	11							
	360			150 psi @ 240 F	15 psi (2-position)	Equal %	Stem up to close	V5011B1070	11	11	11							
	365			175 psi @ 130 F	125 psig / 353 F	Equal %	Stem down to close	VGf21ES60	11	11	11							
	370		175 psi @ 130 F	Linear		VGf21LS60		11	11	11								
	370		400 psi @ 130 F	Equal %		VGf22ES60		11	11	11								
4"	150	Pressure Balanced	125	175 psi @ 130 F	125 psig / 353 F	Equal %	Stem down to close	VGf21EP40	175	175	175							
	150					Linear		VGf21LP40	175	175	175							
	285					Equal %		VGf21EP50	175	175	175							
	320					Linear		VGf21LP50	175	175	175							
	6"					365		Equal %	VGf21EP60	175	175	175						
						370		Linear	VGf21LP60	175	175	175						
						4"		160	Mixing	125	150 psi @ 240 F	N / A	Constant Total	Stem up closes A-AB	V5013B1029	20	20	20
								160	Diverting		150 psi @ 240 F		Constant Total	Stem up closes B-AB	V5013C1027	20	20	20
								150	Mixing		175 psi @ 130 F		Equal % A-AB	Stem up closes A-AB	VGf31EM40	27	27	27
	160							Diverting	175 psi @ 130 F		Linear, Constant Total		Stem up closes B-AB	VGf31LD40	27	27	27	
170	Mixing	400 psi @ 130 F	Equal % A-AB	Stem up closes A-AB	VGf32EM40		27	27	27									
160	Diverting	250	400 psi @ 130 F	Linear, Constant Total	Stem up closes B-AB		VGf32LD40	27	27	27								
5"	250	Mixing	125	150 psi @ 240 F	N / A		Constant Total	Stem up closes A-AB	V5013B1037	16	16		16					
	250	Diverting		150 psi @ 240 F			Constant Total	Stem up closes B-AB	V5013C1035	16	16		16					
	320	Mixing		175 psi @ 130 F			Equal % A-AB	Stem up closes A-AB	VGf31EM50	11	11		11					
	285	Diverting		175 psi @ 130 F			Linear, Constant Total	Stem up closes B-AB	VGf31LD50	11	11		11					
	320	Mixing		250		400 psi @ 130 F	Equal % A-AB	Stem up closes A-AB	VGf32EM50	11	11	11						
	285	Diverting	250	400 psi @ 130 F		Linear, Constant Total	Stem up closes B-AB	VGf32LD50	11	11	11							
	6"	360	Mixing	125		150 psi @ 240 F	N / A	Constant Total	Stem up closes A-AB	V5013B1045	11	11	11					
		360	Diverting			150 psi @ 240 F		Constant Total	Stem up closes B-AB	V5013C1043	11	11	11					
		370	Mixing			175 psi @ 130 F		Equal % A-AB	Stem up closes A-AB	VGf31EM60	11	11	11					
		380	Diverting			175 psi @ 130 F		Linear, Constant Total	Stem up closes B-AB	VGf31LD60	11	11	11					
370		Mixing	250	400 psi @ 130 F	Equal % A-AB	Stem up closes A-AB		VGf32EM60	11	11	11							
380		Diverting	250	400 psi @ 130 F	Linear, Constant Total	Stem up closes B-AB		VGf32LD60	11	11	11							

***Q5022B linkage compatible with VGf valves with 7/16-20UNF stem thread (Manufactured after June, 2005)

VALVE SELECTION

Flanged Globe Valves 4" - 6"

With Dedicated Valve Actuators

Common Features

- ANSI body class 125 or 250
- Close-off pressure = Maximum differential pressure
- Maximum static water pressure: Up to 400 psi
- Maximum steam pressure (VGF, 2-pos or modulating): 100 psi
- Maximum steam pressure (V5011, 2-pos): 15 psi
- Stem travel: 1.5"
- Rangeability: 50:1
- Leakage < 0.05% of Cv
- Body material: Cast iron
- Body trim: Stainless steel stem, brass seat (V5011/13), stainless steel seat (VGF)



Actuator Features		Non-fail Safe	
Actuator O.S. Number		ML7421B1023	ML6421B1040
Power Supply	Voltage	24 Vac	24 Vac
	Frequency	50 / 60 Hz	50 / 60 Hz
	Power	12 VA	11 VA
Actuator Torque	(lb.-in.)	404	404
Control	(0)2-10 Vdc	•	
	4-20 mA (external 500 Ohm Resistor)	•	
	Floating		•
	Two-Position SPDT		•
Fail Safe Action		Stay in Place	Stay in Place
Normal Position (no signal)	(field configurable)	Stem Up	Stay in Place
Actuator Stroke	(inches)	1.5	1.5
Stroke Timing	(seconds)	175	175
High Temperature Kit	Steam Application	43196000-038	43196000-038
Aux Switch	2 x SPDT (24 Vac) (add-on)	43191680-102	43191680-102
Feedback	1 x 220 Ohm Potentiometer (add-on)		43191679-102
	2-10 Vdc (built in)	•	

2-Way Water & Steam Valves ANSI Class III
(< 0.05% Cv) Seat Leakage

Valve Size (inches)	Cv	Valve Type	ANSI Class	Max Static Water Pressure	Max Steam Pressure / Temperature	Flow Characteristic	Valve Action	Valve OS Number	Close-off Pressure, psid				
4"	160	Standard	125	150 psi @ 240 F	15 psi (2-position)	Equal %	Stem down to close	V5011A1858	29	29			
	160			150 psi @ 240 F	15 psi (2-position)	Equal %	Stem up to close	V5011B1013	29	29			
	150			175 psi @ 130 F	125 psig / 353 F	Linear	Stem down to close	VGF21ES40	34	34			
	155			175 psi @ 130 F				VGF21LS40	34	34			
	150			400 psi @ 130 F				VGF22ES40	34	34			
	250		150 psi @ 240 F	15 psi (2-position)	Equal %	Stem up to close	V5011A1882	18	18				
	5"		250	Standard	125	150 psi @ 240 F	15 psi (2-position)	Equal %	Stem up to close	V5011B1047	18	18	
			285			175 psi @ 130 F	125 psig / 353 F	Linear	Stem down to close	VGF21ES50	13	13	
			320			175 psi @ 130 F				VGF21LS50	13	13	
			320			400 psi @ 130 F				VGF22ES50	13	13	
360		150 psi @ 240 F	15 psi (2-position)			Equal %	Stem up to close	V5011A1916	12	12			
6"	360	Standard	125	150 psi @ 240 F	15 psi (2-position)	Equal %	Stem up to close	V5011B1070	12	12			
	365			175 psi @ 130 F	125 psig / 353 F	Linear	Stem down to close	VGF21ES60	13	13			
	370			175 psi @ 130 F				VGF21LS60	13	13			
	370			400 psi @ 130 F				VGF22ES60	13	13			
	4"			150	Pressure Balanced	125	175 psi @ 130 F	125 psig / 353 F	Equal %	Stem down to close	VGF21EP40	175	175
150		Linear	VGF21LP40	175					175				
285		Equal %	VGF21EP50	175					175				
		Linear	VGF21LP50	175					175				
320		Equal %	VGF21EP60	175					175				
370		Linear	VGF21LP60	175					175				
4"	160	Mixing	125	150 psi @ 240 F	N/A	Constant Total	Stem up closes A-AB	V5013B1029	29	29			
	160	Diverting		150 psi @ 240 F		Constant Total	Stem up closes B-AB	V5013C1027	29	29			
	150	Mixing		175 psi @ 130 F		Equal % A-AB	Stem up closes A-AB	VGF31EM40	34	34			
	160	Diverting		175 psi @ 130 F		Linear, Constant Total	Stem up closes B-AB	VGF31LD40	34	34			
	170	Mixing		250		400 psi @ 130 F	Equal % A-AB	Stem up closes A-AB	VGF32EM40	34	34		
	160	Diverting		250		400 psi @ 130 F	Linear, Constant Total	Stem up closes B-AB	VGF32LD40	34	34		
	5"	250	Mixing	125		150 psi @ 240 F	N/A	Constant Total	Stem up closes A-AB	V5013B1037	18	18	
		250	Diverting			150 psi @ 240 F		Constant Total	Stem up closes B-AB	V5013C1035	18	18	
		320	Mixing			175 psi @ 130 F		Equal % A-AB	Stem up closes A-AB	VGF31EM50	13	13	
		285	Diverting			175 psi @ 130 F		Linear, Constant Total	Stem up closes B-AB	VGF31LD50	13	13	
		320	Mixing			250		400 psi @ 130 F	Equal % A-AB	Stem up closes A-AB	VGF32EM50	13	13
		285	Diverting			250		400 psi @ 130 F	Linear, Constant Total	Stem up closes B-AB	VGF32LD50	13	13
6"	360	Mixing	125	150 psi @ 240 F	N/A	Constant Total		Stem up closes A-AB	V5013B1045	12	12		
	360	Diverting		150 psi @ 240 F		Constant Total		Stem up closes B-AB	V5013C1043	12	12		
	370	Mixing		175 psi @ 130 F		Equal % A-AB		Stem up closes A-AB	VGF31EM60	13	13		
	380	Diverting		175 psi @ 130 F		Linear, Constant Total		Stem up closes B-AB	VGF31LD60	13	13		
	370	Mixing	250	400 psi @ 130 F		Equal % A-AB		Stem up closes A-AB	VGF32EM60	13	13		
	380	Diverting	250	400 psi @ 130 F		Linear, Constant Total		Stem up closes B-AB	VGF32LD60	13	13		

Flanged Cage Valves 2½- 6"

The V5051 series advantage lies in its ability to perform like a globe valve while achieving high close-off pressures with a single spring return actuator. This premium valve delivers a high close-off using a single spring return actuator on all valves up to 6". It is highly suitable for medium-pressure steam applications.

Common Features

- Pressure balanced design for high close-off
- Close-off pressure = Maximum differential pressure
- ANSI body class 125
- Stem travel 1.5"
- Body material: Cast iron
- Body valve trim: Stainless steel
- Leakage: 0.01% Cv 2.5"-4" and 0.03% Cv 5"-6"
- Max static water pressure: 150 psi
- Max static steam pressure: 55 psi
- Flow characteristic: Modified linear



2-Way Water & Steam Valves

Valve Size (inches)	Cv	ANSI Class	Max Static Water Pressure	Max Steam Pressure / Temperature	Flow Characteristic	Valve Action	Valve OS Number	Close-off Pressure, psid				
2 1/2"	75	125	150 psi @ 100 F	55 psig / 300 F	Modified Linear	Stem down to close	V5051A3004	150	150	150	150	150
3"	116						V5051A3012	150	150	150	150	150
4"	178						V5051A3020	150	150	150	150	150
5"	318						V5051A3038	150	150	150	150	150
6"	390						V5051A3046	150	150	150	150	150

Q5020C1009 Required		Non-fail Safe			Fail Safe	
Actuator Features		MM6120A1002 MM6120A1200	MM7220A2007 MM7220A2205	MS7620A2007 MS7620A2205 MS7920H2208	MS8120A1007 MS8120A1205	MM4120A1001 MS4120A1209
Actuator O.S. Number						
Power Supply	Voltage	24 Vac	24 Vac	24 Vac	24 Vac	100-250 Vac
	Frequency	50 / 60 Hz	50 / 60 Hz	50 / 60 Hz	50 / 60 Hz	60 Hz
	Power	6 VA	6 VA	16 VA	40 VA	60 VA
Actuator Torque	(lbs.)	175	175	175	175	175
Control	(0)2-10 Vdc		•	•		
	4-20 mA (external 500 Ohm Resistor)		•	•		
	Floating	•	•	•		
	Two-Position SPDT	•	•	•		
	Two-Position SPST		•	•	•	•
Fail Safe Action		Stay-in-Place	Stay-in-Place	Configurable Open/Closed	Configurable Open/Closed	Configurable Open/Closed
Normal Position (no signal)	(field configurable)	Stem Up	Stem Up	Stem Up	Stem Up	Stem Up
Linkage Stroke	(inches)	1.5	1.5	1.5	1.5	1.5
Stroke Timing	(seconds)	95	95	90	90	90
High Temperature Kit	Steam Application					
Aux Switch	2 x SPDT (built in)	0 / 2	0 / 2	0 / 2 / 2	0 / 2	0 / 2
	2 x SPDT (add-on)	SW2-US	SW2-US	SW2-US	SW2-US	SW2-US
Feedback	2-10 Vdc (built in)		•	•		

NPT Globe Valves 1/2- 3"

With Pneumatic Actuators

Common Features

- Rolling diaphragm for long life and low hysteresis
- Easily installation and attachment to the valve
- Direct or reverse acting
- No positive positioner



Actuator Features		Without Positive Positioner										
Actuator O.S. Number		MP953C1000	MP953C1018	MP953C1026	MP953C1067	MP953C1075	MP953C1083	MP953C1554	MP953C1562	MP953D1107	MP953D1131	MP953D1172
Direct / Reverse Acting	DA / RA	DA	DA	DA	DA	DA	DA	DA	DA	RA	RA	RA
Diaphragm Size		5"	5"	5"	8"	8"	8"	13"	13"	7-1/8"	7-1/8"	7-1/8"
Fail Safe Action		Stem Up	Stem Up	Stem Up	Stem Up	Stem Up	Stem Up	Stem Up	Stem Up	Stem Down	Stem Down	Stem Down
Positioner	10psi span	N/A										
	5psi span											
	3psi span											

Valve Size (inches)	Cv	Flow Characteristic	Valve Action	Valve OS Number	Close-off Pressure - See Charts On Page 51										
					A-NC	A-NC	A-NC	B-NC	B-NC	B-NC	N/A	C-NO	C-NO	C-NO	
2-Way Water Valves Straight Through	1/2"	2.9	Equal %	Stem up to close	V5011N3004	A-NC	A-NC	A-NC	B-NC	B-NC	B-NC	N/A	C-NO	C-NO	C-NO
	3/4"	4.7			V5011N3012	A-NC	A-NC	A-NC	B-NC	B-NC	B-NC		C-NO	C-NO	C-NO
	1"	7.3			V5011N3020	A-NC	A-NC	A-NC	B-NC	B-NC	B-NC		C-NO	C-NO	C-NO
	1-1/4"	11.7			V5011N3038	A-NC	A-NC	A-NC	B-NC	B-NC	B-NC		C-NO	C-NO	C-NO
	1-1/4"	18.7			V5011N3046	A-NC	A-NC	A-NC	B-NC	B-NC	B-NC		C-NO	C-NO	C-NO
	1/2"	0.73			V5011N1008	F-NO	F-NO	F-NO	E-NO	E-NO	E-NO		D-NC	D-NC	D-NC
	1/2"	1.16		V5011N1016	F-NO	F-NO	F-NO	E-NO	E-NO	E-NO	D-NC		D-NC	D-NC	
	1/2"	1.85		V5011N1024	F-NO	F-NO	F-NO	E-NO	E-NO	E-NO	D-NC		D-NC	D-NC	
	1/2"	2.9		V5011N1032	F-NO	F-NO	F-NO	E-NO	E-NO	E-NO	D-NC		D-NC	D-NC	
	1/2"	4.7		V5011N1040	F-NO	F-NO	F-NO	E-NO	E-NO	E-NO	D-NC		D-NC	D-NC	
	3/4"	7.3		V5011N1057	F-NO	F-NO	F-NO	E-NO	E-NO	E-NO	D-NC		D-NC	D-NC	
	1"	11.7		V5011N1065	F-NO	F-NO	F-NO	E-NO	E-NO	E-NO	D-NC		D-NC	D-NC	
	1-1/4"	18.7		V5011N1073	F-NO	F-NO	F-NO	E-NO	E-NO	E-NO	D-NC		D-NC	D-NC	
	1-1/2"	29.3		V5011N1081	F-NO	F-NO	F-NO	E-NO	E-NO	E-NO	D-NC		D-NC	D-NC	
	2-Way Steam Valves Straight Through	2"		46.8	V5011N1099	F-NO	F-NO	F-NO	E-NO	E-NO	E-NO		D-NC	D-NC	D-NC
2-1/2"		63	V5011F1105	L-NO	L-NO	L-NO	L-NO	L-NO	L-NO	G-NC	G-NC	G-NC			
3"		100	V5011F1113	L-NO	L-NO	L-NO	L-NO	L-NO	L-NO	G-NC	G-NC	G-NC			
1/2"		0.73	V5011N2006	F*-NO	F*-NO	F*-NO	E*-NO	E*-NO	E*-NO	D*-NC	D*-NC	D*-NC			
1/2"		1.16	V5011N2014	F*-NO	F*-NO	F*-NO	E*-NO	E*-NO	E*-NO	D*-NC	D*-NC	D*-NC			
1/2"		1.85	V5011N2022	F*-NO	F*-NO	F*-NO	E*-NO	E*-NO	E*-NO	D*-NC	D*-NC	D*-NC			
1/2"		2.9	V5011N2030	F*-NO	F*-NO	F*-NO	E*-NO	E*-NO	E*-NO	D*-NC	D*-NC	D*-NC			
1/2"		4.7	V5011N2048	F*-NO	F*-NO	F*-NO	E*-NO	E*-NO	E*-NO	D*-NC	D*-NC	D*-NC			
3/4"		7.3	V5011N2055	F*-NO	F*-NO	F*-NO	E*-NO	E*-NO	E*-NO	D*-NC	D*-NC	D*-NC			
1"		11.7	V5011N2063	F*-NO	F*-NO	F*-NO	E*-NO	E*-NO	E*-NO	D*-NC	D*-NC	D*-NC			
1-1/4"		18.7	V5011N2071	F*-NO	F*-NO	F*-NO	E*-NO	E*-NO	E*-NO	D*-NC	D*-NC	D*-NC			
1-1/2"		29.3	V5011N2089	F*-NO	F*-NO	F*-NO	E*-NO	E*-NO	E*-NO	D*-NC	D*-NC	D*-NC			
2"		46.8	V5011N2097	F*-NO	F*-NO	F*-NO	E*-NO	E*-NO	E*-NO	D*-NC	D*-NC	D*-NC			
2-1/2"		63	V5011G1111	L*-NO	L*-NO	L*-NO	L*-NO	L*-NO	L*-NO	G*-NC	G*-NC	G*-NC			
3"		100	V5011G1129	L*-NO	L*-NO	L*-NO	L*-NO	L*-NO	L*-NO	G*-NC	G*-NC	G*-NC			
3-Way Water Valves Mixing	1/2"	2.9	Linear B-AB / Equal % A-AB	Stem up closes A-AB	V5013N1030	H-NC	H-NC	H-NC	J-NC	J-NC	J-NC	N/A	K-NC	K-NC	K-NC
	1/2"	4.7			V5013N1048	H-NC	H-NC	H-NC	J-NC	J-NC	J-NC		K-NC	K-NC	K-NC
	3/4"	7.3			V5013N1055	H-NC	H-NC	H-NC	J-NC	J-NC	J-NC		K-NC	K-NC	K-NC
	1"	11.7			V5013N1063	H-NC	H-NC	H-NC	J-NC	J-NC	J-NC		K-NC	K-NC	K-NC
	1-1/4"	18.7			V5013N1071	H-NC	H-NC	H-NC	J-NC	J-NC	J-NC		K-NC	K-NC	K-NC
	1-1/2"	29.3			V5013N1089	H-NC	H-NC	H-NC	J-NC	J-NC	J-NC		K-NC	K-NC	K-NC
	2"	46.8			V5013N1097	H-NC	H-NC	H-NC	J-NC	J-NC	J-NC		K-NC	K-NC	K-NC

*The close-off pressure not to exceed rated pressure of steam valve
 NC = Normally Closed
 NO = Normally Open



Chart H

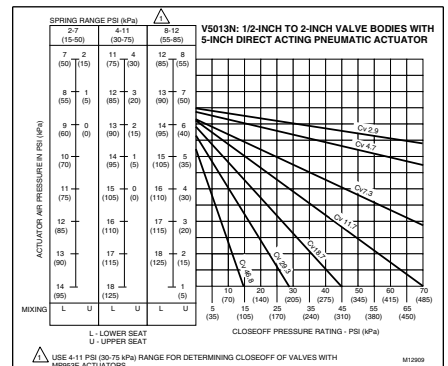

NPT Globe Valves 1/2-3"

With Pneumatic Actuators

Chart A

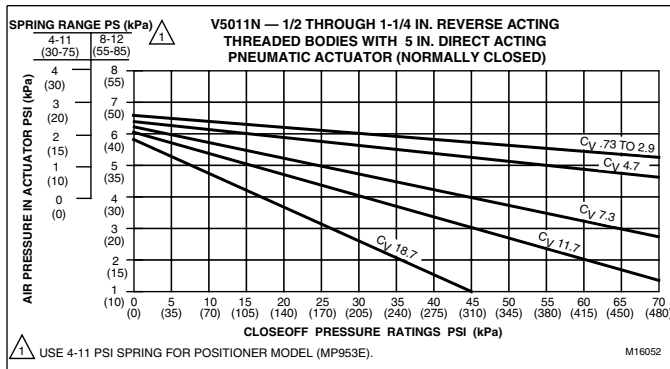

Chart B

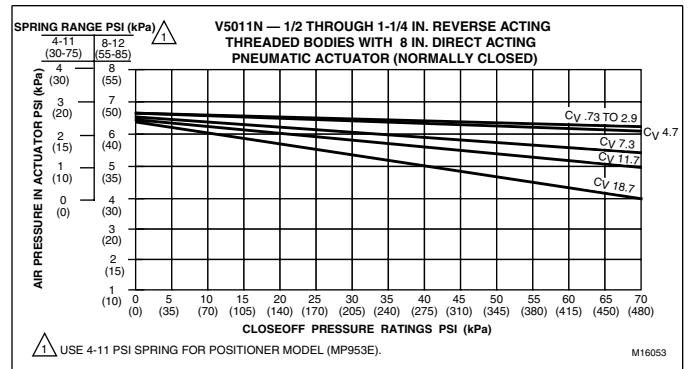

Chart C

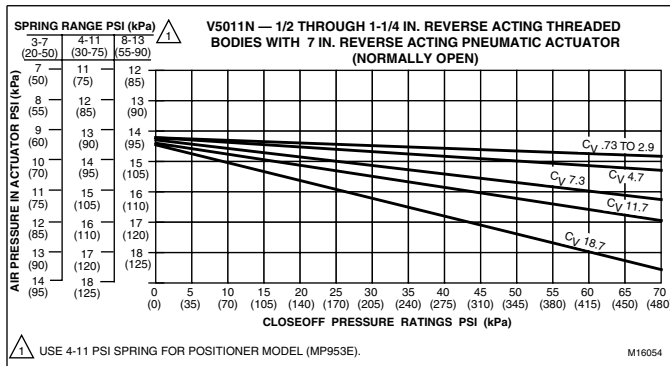

Chart D

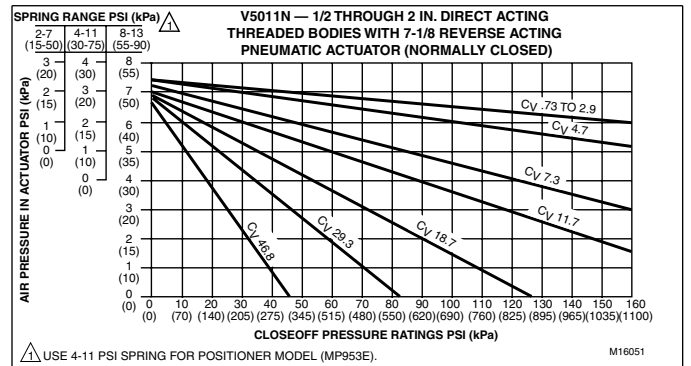

Chart E

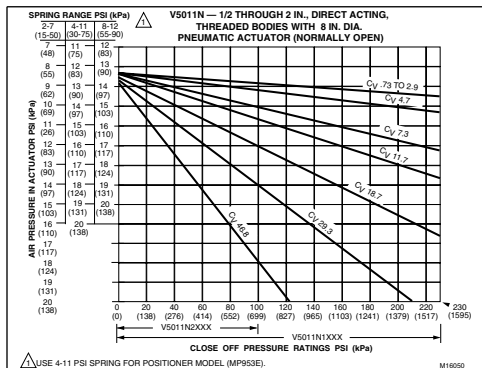

Chart F

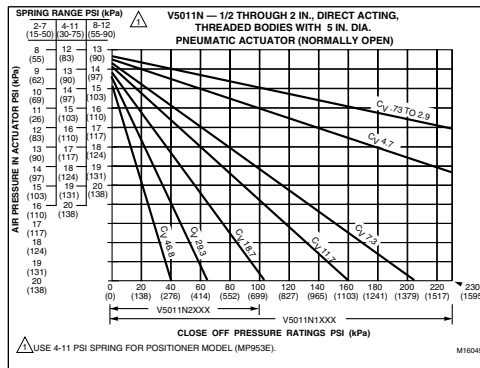

Chart G

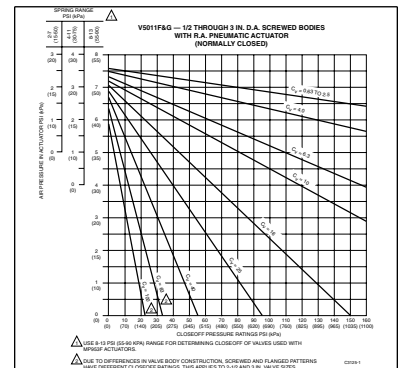

Chart J

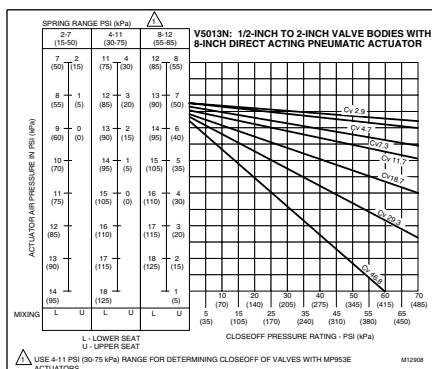

Chart K

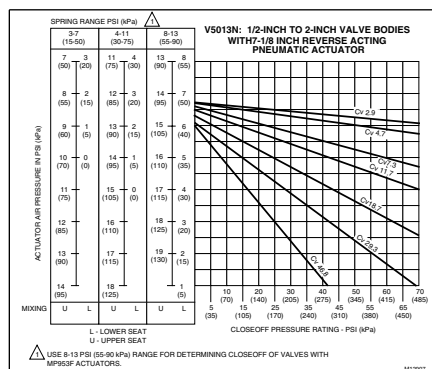
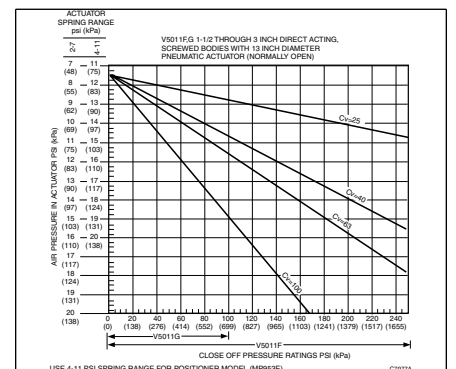

Chart L



VALVE SELECTION

NPT Globe Valves 1/2- 3"

With Pneumatic Actuators

Common Features

- Rolling diaphragm for long life and low hysteresis
- Easily installation and attachment to the valve
- Direct or reverse acting
- Integrated positive positioner



Actuator Features		With Positive Positioner										
Actuator O.S. Number		MP953E1301	MP953E1319	MP953E1327	MP953E1368	MP953E1376	MP953E1384	MP953E1435	MP953E1443	MP953F1093	MP953F1101	MP953F1119
Direct / Reverse Acting	DA / RA	DA	DA	DA	DA	DA	DA	DA	DA	RA	RA	RA\
Diaphragm Size		5"	5"	5"	8"	8"	8"	13"	13"	7-1/8"	7-1/8"	7-1/8"
Fail Safe Action		Stem Up	Stem Up	Stem Up	Stem Up	Stem Up	Stem Up	Stem Up	Stem Up	Stem Down	Stem Down	Stem Down
Positioner	10psi span			•			•		•			•
	5psi span		•			•		•			•	
	3psi span	•			•					•		

Valve Size (inches)	Cv	Flow Characteristic	Valve Action	Valve OS Number	Close-off Pressure - See Charts On Page 53										
					A-NC	A-NC	A-NC	B-NC	B-NC	B-NC	N/A	C-NO	C-NO	C-NO	
2-Way Water Valves Straight Through	1/2"	2.9	Equal %	Stem up to close	V5011N3004	A-NC	A-NC	A-NC	B-NC	B-NC	B-NC	N/A	C-NO	C-NO	C-NO
	3/4"	4.7			V5011N3012	A-NC	A-NC	A-NC	B-NC	B-NC	B-NC		C-NO	C-NO	C-NO
	1"	7.3			V5011N3020	A-NC	A-NC	A-NC	B-NC	B-NC	B-NC		C-NO	C-NO	C-NO
	1-1/4"	11.7			V5011N3038	A-NC	A-NC	A-NC	B-NC	B-NC	B-NC		C-NO	C-NO	C-NO
	1-1/2"	18.7			V5011N3046	A-NC	A-NC	A-NC	B-NC	B-NC	B-NC		C-NO	C-NO	C-NO
	2"	29.3			V5011N1008	F-NO	F-NO	F-NO	E-NO	E-NO	E-NO		D-NC	D-NC	D-NC
	2-1/2"	46.8		Stem down to close	V5011N1016	F-NO	F-NO	F-NO	E-NO	E-NO	E-NO		D-NC	D-NC	D-NC
	3"	63			V5011N1024	F-NO	F-NO	F-NO	E-NO	E-NO	E-NO		D-NC	D-NC	D-NC
	1/2"	1.16			V5011N1032	F-NO	F-NO	F-NO	E-NO	E-NO	E-NO		D-NC	D-NC	D-NC
	1/2"	1.85			V5011N1040	F-NO	F-NO	F-NO	E-NO	E-NO	E-NO		D-NC	D-NC	D-NC
	1/2"	2.9			V5011N1057	F-NO	F-NO	F-NO	E-NO	E-NO	E-NO		D-NC	D-NC	D-NC
	3/4"	4.7			V5011N1065	F-NO	F-NO	F-NO	E-NO	E-NO	E-NO		D-NC	D-NC	D-NC
	1"	7.3			V5011N1073	F-NO	F-NO	F-NO	E-NO	E-NO	E-NO		D-NC	D-NC	D-NC
1-1/4"	11.7	V5011N1081	F-NO	F-NO	F-NO	E-NO	E-NO	E-NO	D-NC	D-NC	D-NC				
1-1/2"	18.7	V5011N1089	F-NO	F-NO	F-NO	E-NO	E-NO	E-NO	D-NC	D-NC	D-NC				
2"	29.3	V5011F1105							G-NC	G-NC	G-NC				
2-1/2"	46.8	V5011F1113							G-NC	G-NC	G-NC				
3"	63														
2-Way Steam Valves Straight Through	1/2"	0.73	Linear	Stem down to close	V5011N2006	F**-NO	F**-NO	F**-NO	E**-NO	E**-NO	E**-NO	N/A	D*-NC	D*-NC	D*-NC
	1/2"	1.16			V5011N2014	F**-NO	F**-NO	F**-NO	E**-NO	E**-NO	E**-NO		D*-NC	D*-NC	D*-NC
	1/2"	1.85			V5011N2022	F**-NO	F**-NO	F**-NO	E**-NO	E**-NO	E**-NO		D*-NC	D*-NC	D*-NC
	1/2"	2.9			V5011N2030	F**-NO	F**-NO	F**-NO	E**-NO	E**-NO	E**-NO		D*-NC	D*-NC	D*-NC
	1/2"	4.7			V5011N2048	F**-NO	F**-NO	F**-NO	E**-NO	E**-NO	E**-NO		D*-NC	D*-NC	D*-NC
	3/4"	7.3			V5011N2055	F**-NO	F**-NO	F**-NO	E**-NO	E**-NO	E**-NO		D*-NC	D*-NC	D*-NC
	1"	11.7			V5011N2063	F**-NO	F**-NO	F**-NO	E**-NO	E**-NO	E**-NO		D*-NC	D*-NC	D*-NC
	1-1/4"	18.7			V5011N2071	F**-NO	F**-NO	F**-NO	E**-NO	E**-NO	E**-NO		D*-NC	D*-NC	D*-NC
	1-1/2"	29.3			V5011N2089	F**-NO	F**-NO	F**-NO	E**-NO	E**-NO	E**-NO		D*-NC	D*-NC	D*-NC
	2"	46.8			V5011N2097	F**-NO	F**-NO	F**-NO	E**-NO	E**-NO	E**-NO		D*-NC	D*-NC	D*-NC
	2-1/2"	63			V5011G1111								G*-NC	G*-NC	G*-NC
	3"	100			V5011G1129								G*-NC	G*-NC	G*-NC
	3-Way Water Valves Mixing	1/2"			2.9	Linear B-AB / Equal % A-AB	Stem up closes A-AB	V5013N1030	H-NC	H-NC	H-NC		J-NC	J-NC	J-NC
1/2"		4.7	V5013N1048	H-NC	H-NC			H-NC	J-NC	J-NC	J-NC	K-NC	K-NC	K-NC	
3/4"		7.3	V5013N1055	H-NC	H-NC			H-NC	J-NC	J-NC	J-NC	K-NC	K-NC	K-NC	
1"		11.7	V5013N1063	H-NC	H-NC			H-NC	J-NC	J-NC	J-NC	K-NC	K-NC	K-NC	
1-1/4"		18.7	V5013N1071	H-NC	H-NC			H-NC	J-NC	J-NC	J-NC	K-NC	K-NC	K-NC	
1-1/2"		29.3	V5013N1089	H-NC	H-NC			H-NC	J-NC	J-NC	J-NC	K-NC	K-NC	K-NC	
2"		46.8	V5013N1097	H-NC	H-NC			H-NC	J-NC	J-NC	J-NC	K-NC	K-NC	K-NC	

*The close-off pressure not to exceed rated pressure of steam valve
 **The close-off pressure not to exceed rated pressure of steam valve. Use 4-11 spring range for positive positioner models.
 NC = Normally Closed
 NO = Normally Open

NPT Globe Valves 1/2-3"

With Pneumatic Actuators

Chart A

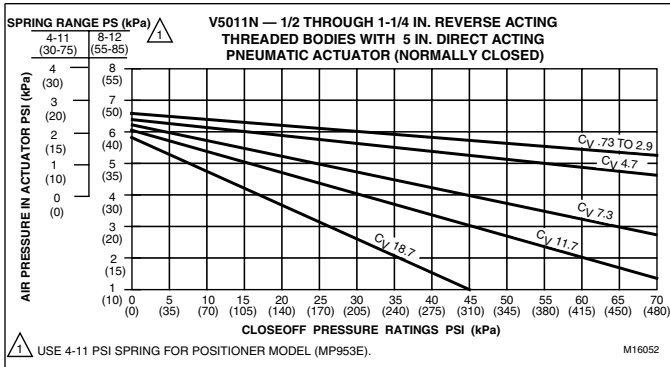

Chart B

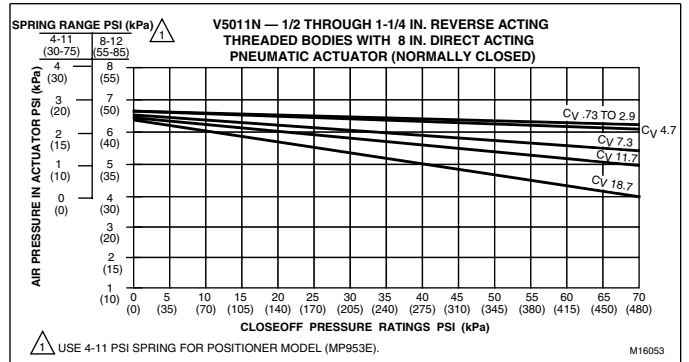

Chart C

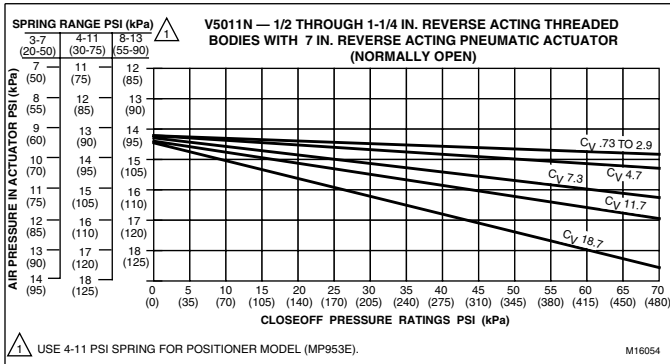

Chart D

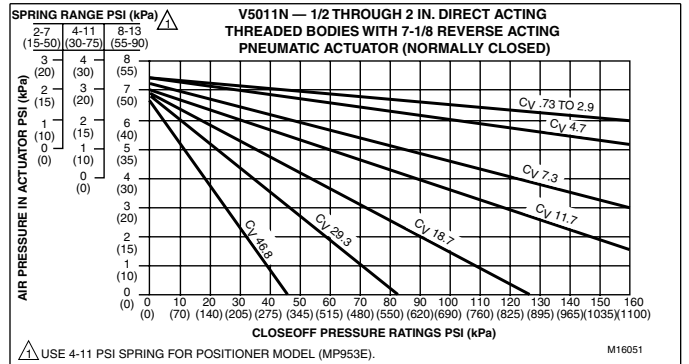

Chart E

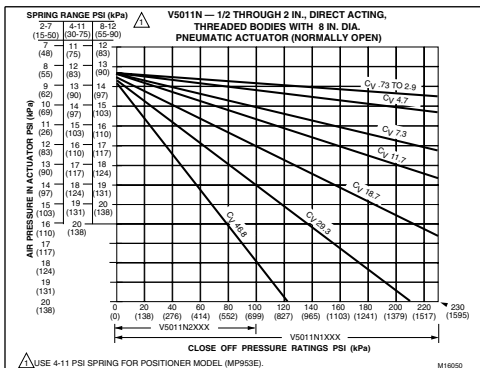

Chart F

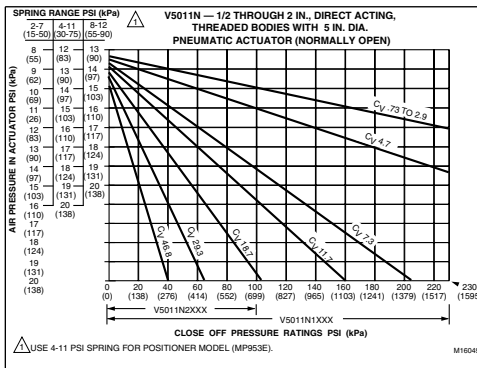

Chart G

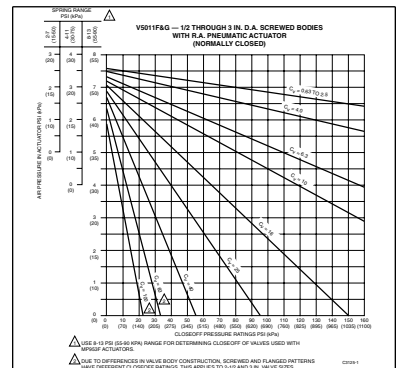

Chart H

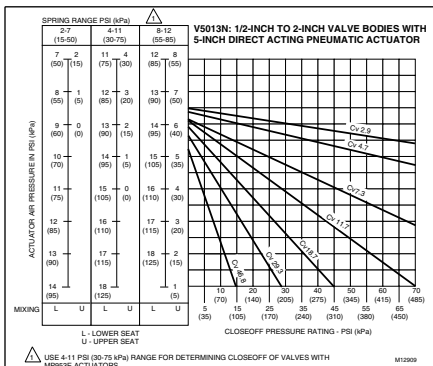

Chart J

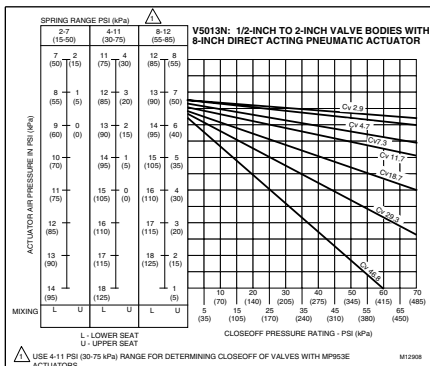
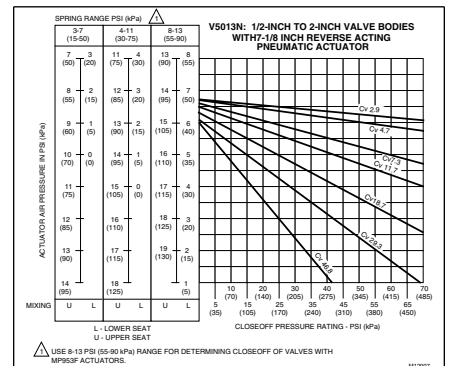

Chart K



VALVE SELECTION

Flanged Globe Valves 2½- 3"

With Pneumatic Actuators

Common Features

- Rolling diaphragm for long life and low hysteresis
- Easily installation and attachment to the valve
- Direct or reverse acting
- No positive positioner



Actuator Features		Without Positive Positioner							
Actuator O.S. Number		MP953C1067	MP953C1075	MP953C1083	MP953C1554	MP953C1562	MP953D1107	MP953D1131	MP953D1172
Direct / Reverse Acting	DA / RA	DA	DA	DA	DA	DA	RA	RA	RA
Diaphragm Size		8"	8"	8"	13"	13"	7-1/8"	7-1/8"	7-1/8"
Fail Safe Action		Stem Up	Stem Up	Stem Up	Stem Up	Stem Up	Stem Down	Stem Down	Stem Down
Positioner	10psi span								
	5psi span								
	3psi span								

2-Way Water & Steam Valves

3-Way Water Valves

Valve Size (Inches)	Cv	Valve Type	Max Static Water Pressure	ANSI Class	Max Steam Pressure	Flow Characteristic	Valve Action	Valve OS Number	Close-off Pressure - See Charts On Page 55								
2-1/2"	63	Standard	250 psi	125	15 psi (2-position)	Equal %	Stem down to close	V5011A1734	M*-NO	M*-NO	M*-NO	P*-NO	P*-NO	N*-NC	N*-NC	N*-NC	
	70	Pressure Balanced	175 psi					VGF21EP25	L*-NO	L*-NO	L*-NO	O*-NO	O*-NO	R*-NC	R*-NC	R*-NC	
	70	Standard						VGF21ES25	L*-NO	L*-NO	L*-NO	O*-NO	O*-NO	R*-NC	R*-NC	R*-NC	
	72	Pressure Balanced	400 psi	125 psig / 353 F	VGF21LP25	L*-NO		L*-NO	L*-NO	O*-NO	O*-NO	R*-NC	R*-NC	R*-NC			
	70	Standard		VGF21LS25	L*-NO	L*-NO		L*-NO	O*-NO	O*-NO	R*-NC	R*-NC	R*-NC				
	70	Standard	250	15 psi (2-position)	Equal %	V5011A1767		M*-NO	M*-NO	M*-NO	P*-NO	P*-NO	N*-NC	N*-NC	N*-NC		
3"	100	Standard	250 psi	125	125 psig / 353 F	Equal %		V5011A1734	M*-NO	M*-NO	M*-NO	P*-NO	P*-NO	N*-NC	N*-NC	N*-NC	
	115	Pressure Balanced	175 psi					VGF21EP30	L*-NO	L*-NO	L*-NO	O*-NO	O*-NO	R*-NC	R*-NC	R*-NC	
	115	Standard						VGF21ES30	L*-NO	L*-NO	L*-NO	O*-NO	O*-NO	R*-NC	R*-NC	R*-NC	
	120	Pressure Balanced	400 psi	250	15 psi (2-position)	Equal %		VGF21LP30	L*-NO	L*-NO	L*-NO	O*-NO	O*-NO	R*-NC	R*-NC	R*-NC	
	125	Standard		125 psig / 353 F	VGF21LS30	L*-NO		L*-NO	L*-NO	O*-NO	O*-NO	R*-NC	R*-NC	R*-NC			
	120	Standard	250	125 psig / 353 F	Linear	VGF22ES30		L*-NO	L*-NO	L*-NO	O*-NO	O*-NO	R*-NC	R*-NC	R*-NC		
2-1/2"	63	Mixing	250 psi	125	N/A	Constant Total	Stem up closes A-AB	V5013B1003	S-NC	S-NC	S-NC	T-NC	T-NC	U-NO	U-NO	U-NO	
	63	Diverting	250 psi			Constant Total	Stem up closes B-AB	V5013C1001	S-NC	S-NC	S-NC	T-NC	T-NC	U-NO	U-NO	U-NO	
	70	Mixing	175 psi			Equal % A-AB	Stem up closes A-AB	VGF31EM25	L-NC	L-NC	L-NC	O-NC	O-NC	R-NO	R-NO	R-NO	
	70	Diverting	175 psi			Linear, Constant Total	Stem up closes B-AB	VGF31LD25	L-NC	L-NC	L-NC	O-NC	O-NC	R-NO	R-NO	R-NO	
	70	Mixing	400 psi			250	Equal % A-AB	Stem up closes A-AB	VGF32EM25	L-NC	L-NC	L-NC	O-NC	O-NC	R-NO	R-NO	R-NO
	70	Diverting	400 psi			250	Linear, Constant Total	Stem up closes B-AB	VGF32LD25	L-NC	L-NC	L-NC	O-NC	O-NC	R-NO	R-NO	R-NO
3"	100	Mixing	250 psi	125	N/A	Constant Total	Stem up closes A-AB	V5013B1011	S-NC	S-NC	S-NC	T-NC	T-NC	U-NO	U-NO	U-NO	
	100	Diverting	250 psi			Constant Total	Stem up closes B-AB	V5013C1019	S-NC	S-NC	S-NC	T-NC	T-NC	U-NO	U-NO	U-NO	
	120	Mixing	175 psi			Equal % A-AB	Stem up closes A-AB	VGF31EM30	L-NC	L-NC	L-NC	O-NC	O-NC	R-NO	R-NO	R-NO	
	120	Diverting	175 psi			Linear, Constant Total	Stem up closes B-AB	VGF31LD30	L-NC	L-NC	L-NC	O-NC	O-NC	R-NO	R-NO	R-NO	
	115	Mixing	400 psi			250	Equal % A-AB	Stem up closes A-AB	VGF32EM30	L-NC	L-NC	L-NC	O-NC	O-NC	R-NO	R-NO	R-NO
	120	Diverting	400 psi			250	Linear, Constant Total	Stem up closes B-AB	VGF32LD30	L-NC	L-NC	L-NC	O-NC	O-NC	R-NO	R-NO	R-NO

*The close-off pressure not to exceed rated pressure of steam valve
 NC = Normally Closed
 NO = Normally Open

Flanged Globe Valves 2½- 3"

With Pneumatic Actuators

Chart L

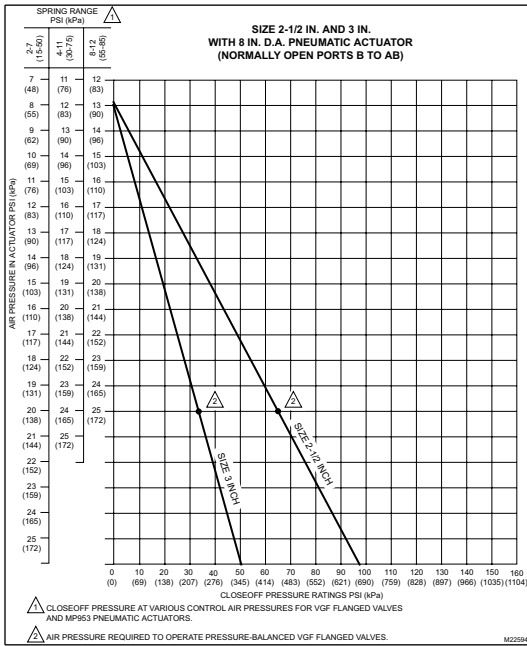

Chart M

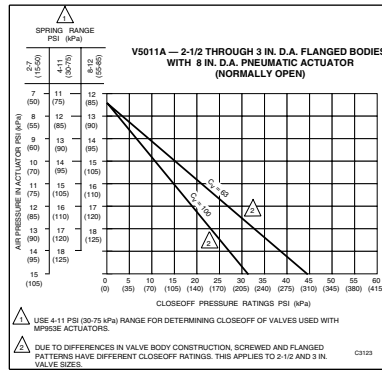

Chart N

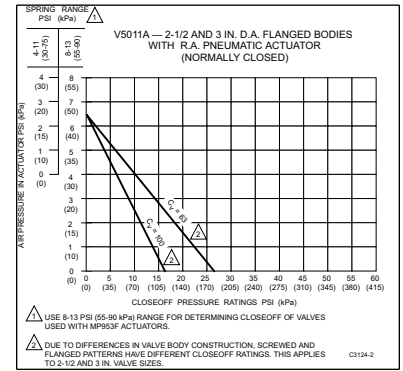

Chart O

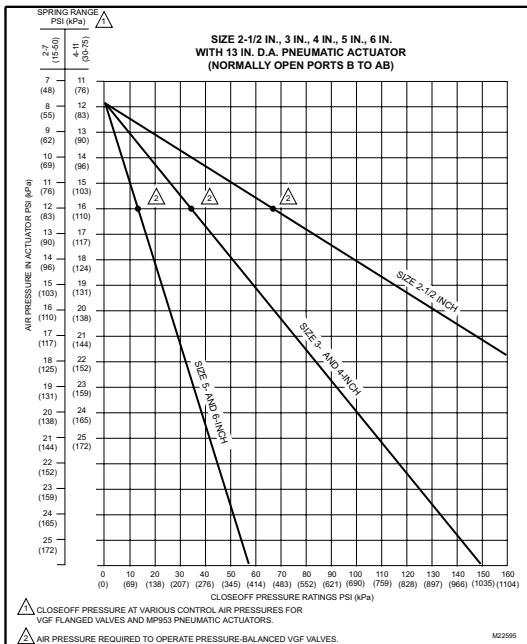

Chart P

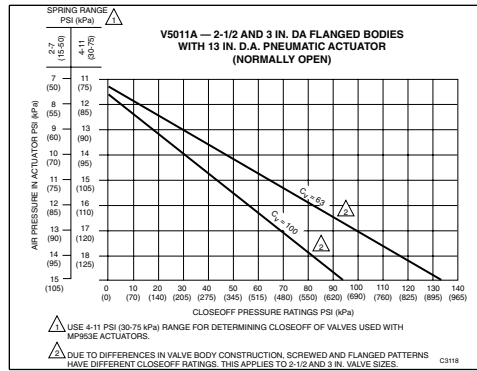

Chart R

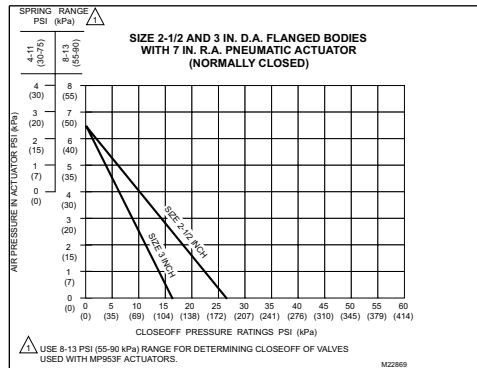

Chart S

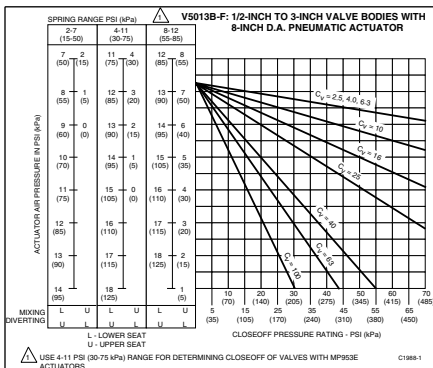

Chart T

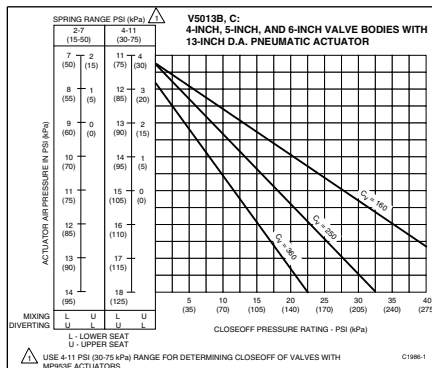
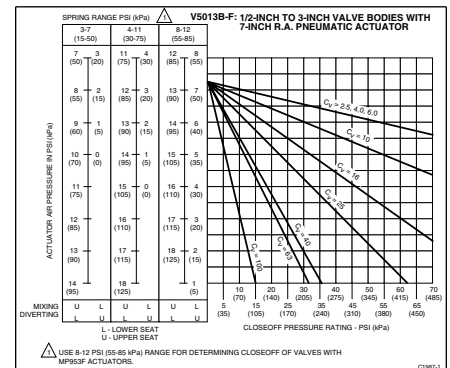

Chart U



VALVE SELECTION

Flanged Globe Valves 2½- 3"

With Pneumatic Actuators

Common Features

- Rolling diaphragm for long life and low hysteresis
- Easily installation and attachment to the valve
- Direct or reverse acting
- Integrated positive positioner



Actuator Features		With Positive Positioner							
Actuator O.S. Number		MP953E1368	MP953E1376	MP953E1384	MP953E1435	MP953E1443	MP953F1093	MP953F1101	MP953F1119
Direct / Reverse Acting	DA / RA	DA	DA	DA	DA	DA	RA	RA	RA\
Diaphragm Size		8"	8"	8"	13"	13"	7-1/8"	7-1/8"	7-1/8"
Fail Safe Action		Stem Up	Stem Up	Stem Up	Stem Up	Stem Up	Stem Down	Stem Down	Stem Down
Positioner	10psi span			•		•			•
	5psi span		•		•			•	
	3psi span	•					•		

2-Way Water & Steam Valves

3-Way Water Valves

Valve Size (Inches)	Cv	Valve Type	Max Static Water Pressure	ANSI Class	Max Steam Pressure	Flow Characteristic	Valve Action	Valve OS Number	Close-off Pressure - See Charts On Page 57									
2-1/2"	63	Standard	250 psi	125	15 psi (2-position)	Equal %	Stem down to close	V5011A1734	M**-NO	M**-NO	M**-NO	P**-NO	P**-NO	N**-NC	N**-NC	N**-NC		
	70	Pressure Balanced	175 psi					125 psig / 353 F	Equal %	VGF21EP25	L**-NO	L**-NO	L**-NO	O**-NO	O**-NO	R**-NC	R**-NC	R**-NC
	70	Standard								VGF21ES25	L**-NO	L**-NO	L**-NO	O**-NO	O**-NO	R**-NC	R**-NC	R**-NC
	72	Pressure Balanced	VGF21LP25	L**-NO	L**-NO	L**-NO			O**-NO	O**-NO	R**-NC	R**-NC	R**-NC					
	70	Standard	VGF21LS25	L**-NO	L**-NO	L**-NO			O**-NO	O**-NO	R**-NC	R**-NC	R**-NC					
	70	Standard	400 psi	250	Equal %	VGF22ES25			L**-NO	L**-NO	L**-NO	O**-NO	O**-NO	R**-NC	R**-NC	R**-NC		
3"	100	Standard	250 psi	125	15 psi (2-position)	Equal %			V5011A1767	M**-NO	M**-NO	M**-NO	P**-NO	P**-NO	N**-NC	N**-NC	N**-NC	
	115	Pressure Balanced	175 psi					125 psig / 353 F	Equal %	VGF21EP30	L**-NO	L**-NO	L**-NO	O**-NO	O**-NO	R**-NC	R**-NC	R**-NC
	115	Standard								VGF21ES30	L**-NO	L**-NO	L**-NO	O**-NO	O**-NO	R**-NC	R**-NC	R**-NC
	120	Pressure Balanced	VGF21LP30	L**-NO	L**-NO	L**-NO			O**-NO	O**-NO	R**-NC	R**-NC	R**-NC					
	125	Standard	400 psi	250	Linear	VGF21LS30			L**-NO	L**-NO	L**-NO	O**-NO	O**-NO	R**-NC	R**-NC	R**-NC		
	120	Standard	400 psi	250	Equal %	VGF22ES30			L**-NO	L**-NO	L**-NO	O**-NO	O**-NO	R**-NC	R**-NC	R**-NC		
2-1/2"	63	Mixing	250 psi	125	N/A	Constant Total	Stem up closes A-AB		V5013B1003	S-NC	S-NC	S-NC	T-NC	T-NC	U-NO	U-NO	U-NO	
	63	Diverting	250 psi			Constant Total	Stem up closes B-AB	V5013C1001	S-NC	S-NC	S-NC	T-NC	T-NC	U-NO	U-NO	U-NO		
	70	Mixing	175 psi			Equal % A-AB	Stem up closes A-AB	VGF31EM25	L-NC	L-NC	L-NC	O-NC	O-NC	R-NO	R-NO	R-NO		
	70	Diverting	175 psi			Linear, Constant Total	Stem up closes B-AB	VGF31LD25	L-NC	L-NC	L-NC	O-NC	O-NC	R-NO	R-NO	R-NO		
	70	Mixing	400 psi			250	Equal % A-AB	Stem up closes A-AB	VGF32EM25	L-NC	L-NC	L-NC	O-NC	O-NC	R-NO	R-NO	R-NO	
	70	Diverting	400 psi			250	Linear, Constant Total	Stem up closes B-AB	VGF32LD25	L-NC	L-NC	L-NC	O-NC	O-NC	R-NO	R-NO	R-NO	
3"	100	Mixing	250 psi	125	N/A	Constant Total	Stem up closes A-AB	V5013B1011	S-NC	S-NC	S-NC	T-NC	T-NC	U-NO	U-NO	U-NO		
	100	Diverting	250 psi			Constant Total	Stem up closes B-AB	V5013C1019	S-NC	S-NC	S-NC	T-NC	T-NC	U-NO	U-NO	U-NO		
	120	Mixing	175 psi			Equal % A-AB	Stem up closes A-AB	VGF31EM30	L-NC	L-NC	L-NC	O-NC	O-NC	R-NO	R-NO	R-NO		
	120	Diverting	175 psi			Linear, Constant Total	Stem up closes B-AB	VGF31LD30	L-NC	L-NC	L-NC	O-NC	O-NC	R-NO	R-NO	R-NO		
	115	Mixing	400 psi			250	Equal % A-AB	Stem up closes A-AB	VGF32EM30	L-NC	L-NC	L-NC	O-NC	O-NC	R-NO	R-NO	R-NO	
	120	Diverting	400 psi			250	Linear, Constant Total	Stem up closes B-AB	VGF32LD30	L-NC	L-NC	L-NC	O-NC	O-NC	R-NO	R-NO	R-NO	

*The close-off pressure not to exceed rated pressure of steam valve

**The close-off pressure not to exceed rated pressure of steam valve. Use 4-11 spring range for positive positioner models.

NC = Normally Closed

NO = Normally Open

Flanged Globe Valves 2½- 3"

With Pneumatic Actuators

Chart L

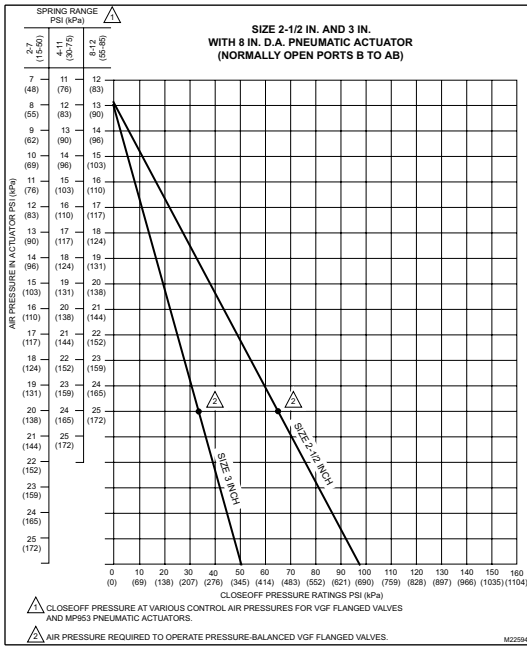

Flanged Globe Valves 4" - 6"

With Pneumatic Actuators

Common Features

- Rolling diaphragm for long life and low hysteresis
- Easily installation and attachment to the valve
- Direct or reverse acting



Actuator Features	Without Positive Positioner			With Positive Positioner		
	MP953C1471	MP953C1489	MP953C1547	MP953E1285	MP953E1400	MP953E1418
Actuator .S. Number						
Diaphragm	13"	13"	8"	8"	13"	13"
Action	DA	DA	DA	DA	DA	DA
Spring Range	2-7psi	4-11psi	3-15psi	4-11psi	4-11psi	4-11psi
Positioner Span	n/a	n/a	n/a	5psi range	5psi range	10psi range
Stroke	1-1/2"	1-1/2"	1-1/2"	1-1/2"	1-1/2"	1-1/2"

2-Way Water & Steam Valves

Valve Size (inches)	Cv	Valve Type	Max Static Water Pressure	ANSI Class	Max Steam Pressure	Flow Characteristic	Valve Action	Valve OS Number	Close-off Pressure - See Charts On Page 57								
4"	160	Standard	250 psi	125	15 psi (2-position)	Equal %	Stem down to close	V5011A1858	V*-NO	V*-NO	V*-NO	V**NO	V**NO	V**NO			
	160	Standard	250 psi					V5011B1013	W*-NO	W*-NO	W*-NO	W**NO	W**NO	W**NO			
	150	Pressure Balanced	175 psi				125 psig / 353 F	Linear	Stem down to close	VGF21EP40	O*-NO	O*-NO	O*-NO	O**NO	O**NO	O**NO	
	150	Standard	175 psi							VGF21ES40	O*-NO	O*-NO	O*-NO	O**NO	O**NO	O**NO	
	150	Pressure Balanced	175 psi							VGF21LP40	O*-NO	O*-NO	O*-NO	O**NO	O**NO	O**NO	
	155	Standard	175 psi	250	Linear	Stem down to close	VGF21LS40	O*-NO	O*-NO	O*-NO	O**NO	O**NO	O**NO				
	150		400 psi				VGF22ES40	O*-NO	O*-NO	O*-NO	O**NO	O**NO	O**NO				
	250	Pressure Balanced	250 psi	125	15 psi (2-position)	Equal %	Stem up to close	V5011A1882	V*-NO	V*-NO	V*-NO	V**NO	V**NO	V**NO			
	250		250 psi					V5011B1047	W*-NO	W*-NO	W*-NO	W**NO	W**NO	W**NO			
	285		175 psi				125 psig / 353 F	Linear	Stem down to close	VGF21EP50	O*-NO	O*-NO	O*-NO	O**NO	O**NO	O**NO	
285	Standard		175 psi							VGF21ES50	O*-NO	O*-NO	O*-NO	O**NO	O**NO	O**NO	
320	Pressure Balanced		175 psi							VGF21LP50	O*-NO	O*-NO	O*-NO	O**NO	O**NO	O**NO	
320	Standard	175 psi	250	Linear	Stem down to close	VGF21LS50	O*-NO	O*-NO	O*-NO	O**NO	O**NO	O**NO					
320		400 psi				VGF22ES50	O*-NO	O*-NO	O*-NO	O**NO	O**NO	O**NO					
360	Pressure Balanced	250 psi	125	15 psi (2-position)	Equal %	Stem up to close	V5011A1916	V*-NO	V*-NO	V*-NO	V**NO	V**NO	V**NO				
360		250 psi					V5011B1070	W*-NO	W*-NO	W*-NO	W**NO	W**NO	W**NO				
365		175 psi				125 psig / 353 F	Linear	Stem down to close	VGF21EP60	O*-NO	O*-NO	O*-NO	O**NO	O**NO	O**NO		
365		Standard							175 psi	VGF21ES60	O*-NO	O*-NO	O*-NO	O**NO	O**NO	O**NO	
370		Pressure Balanced							175 psi	VGF21LP60	O*-NO	O*-NO	O*-NO	O**NO	O**NO	O**NO	
370		Standard				175 psi	250	Linear	Stem down to close	VGF21LS60	O*-NO	O*-NO	O*-NO	O**NO	O**NO	O**NO	
370						400 psi				VGF22ES60	O*-NO	O*-NO	O*-NO	O**NO	O**NO	O**NO	
4"	160	Mixing	250 psi	125	N/A	Constant Total	Stem up closes A-AB	V5013B1029	T-NC	T-NC	T-NC	T-NC	T-NC	T-NC			
	160	Diverting	250 psi					V5013C1027	T-NC	T-NC	T-NC	T-NC	T-NC	T-NC			
	150	Mixing	175 psi				250	Linear, Constant Total	Stem up closes A-AB	VGF31EM40	O-NC	O-NC	O-NC	O-NC	O-NC	O-NC	
	160	Diverting	175 psi							VGF31LD40	O-NC	O-NC	O-NC	O-NC	O-NC	O-NC	
	170	Mixing	400 psi							VGF32EM40	O-NC	O-NC	O-NC	O-NC	O-NC	O-NC	
	160	Diverting	400 psi	250	Linear, Constant Total	Stem up closes B-AB	VGF32LD40	O-NC	O-NC	O-NC	O-NC	O-NC	O-NC				
	250		250 psi				V5013B1037	T-NC	T-NC	T-NC	T-NC	T-NC	T-NC				
	250	Diverting	250 psi	125	Constant Total	Stem up closes A-AB	V5013C1035	T-NC	T-NC	T-NC	T-NC	T-NC	T-NC				
	320		Mixing				175 psi	250	Linear, Constant Total	Stem up closes A-AB	VGF31EM50	O-NC	O-NC	O-NC	O-NC	O-NC	O-NC
	285		Diverting				175 psi				VGF31LD50	O-NC	O-NC	O-NC	O-NC	O-NC	O-NC
320	Mixing		400 psi				VGF32EM50				O-NC	O-NC	O-NC	O-NC	O-NC	O-NC	
285	Diverting		400 psi				250	Linear, Constant Total	Stem up closes B-AB	VGF32LD50	O-NC	O-NC	O-NC	O-NC	O-NC	O-NC	
360		Mixing	250 psi	V5013B1045	T-NC	T-NC				T-NC	T-NC	T-NC	T-NC				
360	Diverting	250 psi	125	Constant Total	Stem up closes B-AB	V5013C1043	T-NC	T-NC	T-NC	T-NC	T-NC	T-NC					
370		Mixing				175 psi	250	Linear, Constant Total	Stem up closes A-AB	VGF31EM60	O-NC	O-NC	O-NC	O-NC	O-NC	O-NC	
380		Diverting				175 psi				VGF31LD60	O-NC	O-NC	O-NC	O-NC	O-NC	O-NC	
370		Mixing				400 psi				VGF32EM60	O-NC	O-NC	O-NC	O-NC	O-NC	O-NC	
380		Diverting				400 psi	250	Linear, Constant Total	Stem up closes B-AB	VGF32LD60	O-NC	O-NC	O-NC	O-NC	O-NC	O-NC	

*The close-off pressure not to exceed rated pressure of steam valve
 **The close-off pressure not to exceed rated pressure of steam valve. Use 4-11 spring range for positive positioner models.
 NC = Normally Closed
 NO = Normally Open

Flanged Globe Valves 4" - 6"

With Pneumatic Actuators

VALVE SELECTION

Chart V

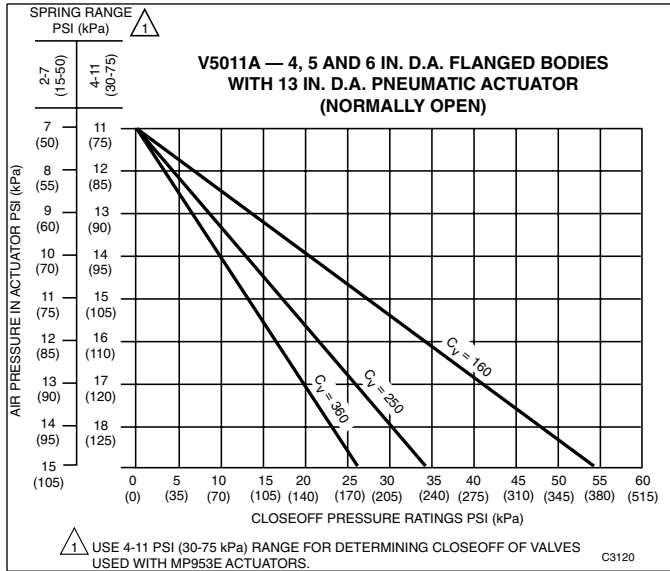

Chart W

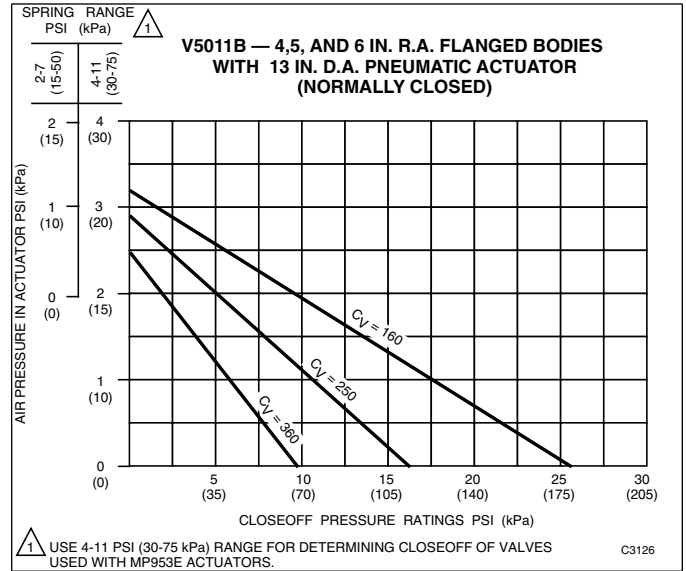

Chart O

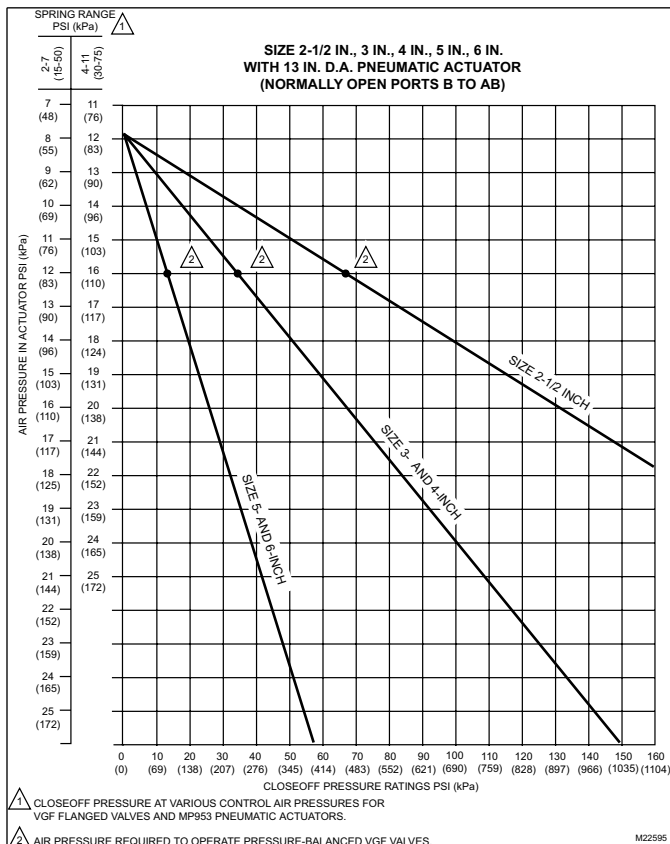
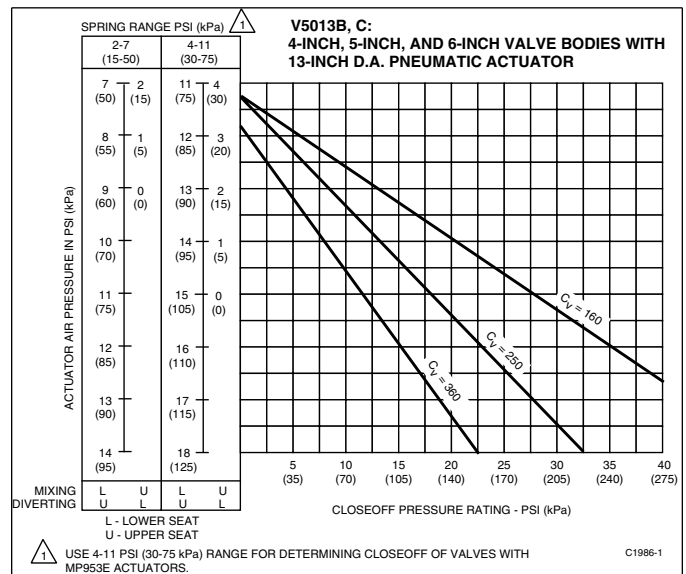

Chart T



Resilient Seat Butterfly Valves

2-Way Electrically-Actuated Control

Honeywell Resilient Seat Butterfly Valves family (VFF) offers options in sizes 2" to 20", highlighted with an industry unique tandem mount using Honeywell direct coupled actuators on valves up to 8" size.

Common Features

- Honeywell direct coupled actuators up to 8" size
- Maximum static pressure 175 psi at 250°F
- Body style: lugged butterfly valve, full-cut (150-175 psid close-off) or under-cut disc (50 psid close-off)
- ANSI 125/150 flanged connections
- Bubble-tight ANSI class VI seat leakage at rated close-off
- Heaters built into NEMA 4X and NEMA 6 actuators
- Controlled media: Water or glycol solutions up to 50% concentration
- Flow characteristics: Equal percentage from 20°-60° stem rotation, modified linear over full stroke
- Normally closed configuration (field configurable)
- Resilient Seat Butterfly Valves come with factory-fitted actuators



2-Way Normally Closed (Field-Configurable Normally Open)

Actuator Features		Non-fail Safe					
		Floating			Modulating		
Actuator O.S. Number	MN6134A1003	Industrial Actuators			MN7234A2008	Industrial Actuators	
		NEMA 2	NEMA 4X	NEMA 4	NEMA 2	NEMA 4X	NEMA 4
Power Supply	Voltage	24 Vac	120 Vac	120 Vac	24 Vac	120 Vac	120 Vac
	Frequency	50 / 60 Hz	50 / 60 Hz	50 / 60 Hz	50 / 60 Hz	50 / 60 Hz	50 / 60 Hz
	Power (* tandem mount)	9 / 18* VA	1.4 - 3.0 ALR	3.2 - 4.0 ALR	9 / 18* VA	1.4 - 3.0 ALR	3.2 - 4.0 ALR
Actuator Torque	lb.-in.	300 / 600*	300 - 6,500	8,850 - 31,000	300 / 600*	300 - 6,500	8,850 - 31,000
Control	(0)2-10 Vdc				•	•	•
	4-20 mA (external 500 ohm resistor)				•	In-built	In-built
	Floating	24 Vac	120 Vac	120 Vac	24 Vac		
	2-Position	•	•	•	•		
Fail Safe Action		Stay in Place	Stay in Place	Stay in Place	Stay in Place	Stay in Place	Stay in Place
Normal Position		Configurable Open / Closed	Configurable Open / Closed	Configurable Open / Closed	Configurable Open / Closed	Configurable Open / Closed	Configurable Open / Closed
Aux Switch	Built in		2 x SPDT	2 x SPDT		2 x SPDT	2 x SPDT
	Add-On	SW2-US			SW2-US		
Feedback	Built in				2-10 Vdc	4-20mA / 2-10Vdc	4-20mA / 2-10Vdc
Manual Override			•	•		•	•
Conduit Connection		•	•	•	•	•	•
Waterproof			•	•		•	•
Corrosion-resistant			•	•		•	•
Anti-condensate heater			•	•		•	•

Valve Size (inches)	Cv @ 60°	Cv @ 90°	Close-off (psid)	Valve O.S. Number					
2"	61	144	175	VFF2FW1Y2A	VFF2FW1YXA		VFF2FW1Y2B	VFF2FW1YXB	
			250						
2 1/2"	107	282	175	VFF2GW1Y2A	VFF2GW1YXA		VFF2GW1Y2B	VFF2GW1YXB	
			250						
3"	154	461	175	VFF2HW1Y2A	VFF2HW1YXA		VFF2HW1Y2B	VFF2HW1YXB	
			250						
4"	274	841	50	VFF2JV1Y2A	VFF2JV1YXA		VFF2JV1Y2B	VFF2JV1YXB	
			175	VFF2JW1Y2A	VFF2JW1YXA		VFF2JW1Y2B	VFF2JW1YXB	
			250						
5"	428	1376	50	VFF2KV1Y2A*	VFF2KV1YXA		VFF2KV1Y2B*	VFF2KV1YXB	
			175	VFF2KW1Y2A	VFF2KW1YXA		VFF2KW1Y2B	VFF2KW1YXB	
			250						
6"	567	1850	50	VFF2LW1Y2A**	VFF2LV1YXA		VFF2LW1Y2B**	VFF2LV1YXB	
			175	VFF2LW1Y2A	VFF2LW1YXA		VFF2LW1Y2B	VFF2LW1YXB	
			250						
8"	1081	3316	50	VFF2MV1Y2A	VFF2MV1YXA		VFF2MV1Y2B	VFF2MV1YXB	
			175		VFF2MW1YXA			VFF2MW1YXB	
			250						
10"	1710	5430	50		VFF2NV1YXA			VFF2NV1YXB	
			175		VFF2NW1YXA			VFF2NW1YXB	
			250						
12"	2563	8077	50		VFF2PV1YXA			VFF2PV1YXB	
			175		VFF2PW1YXA			VFF2PW1YXB	
			250						
14"	3384	10538	50		VFF2RV1YXA			VFF2RV1YXB	
			150		VFF2RW1YXA			VFF2RW1YXB	
			250						
16"	4483	13966	50		VFF2SV1YXA			VFF2SV1YXB	
			150			VFF2SW1Y4A			VFF2SW1Y4B
			250						
18"	5736	17214	50		VFF2TV1YXA			VFF2TV1YXB	
			150			VFF2TW1Y4A			VFF2TW1Y4B
			250						
20"	7144	22339	50			VFF2UV1Y4A			VFF2UV1Y4B
			150			VFF2UW1Y4A			VFF2UW1Y4B
			250						

*Chilled water service only.
 **Use full cut valves – requires same actuator torque.

Resilient Seat Butterfly Valves

2-Way Electrically-Actuated Control

VALVE SELECTION

Actuator Features		Fail Safe			Valve Only End-of-line Service	
		2-Position		Modulating		
Actuator O.S. Number		MS8120A1007	MS4120A1001	MS7520A2007		
		NEMA 2	NEMA 4X	NEMA 6		
Power Supply	Voltage	24 Vac	100-250 Vac	24 Vac		
	Frequency	60 Hz	60 Hz	50 / 60 Hz		
	Power (* tandem mount)	40 / 80* VA	60 / 120* VA	16 / 32* VA		
Actuator Torque	lb.-in.	175 / 350*	175 / 350*	175 / 350*		
Control	(0)2-10 Vdc			•		
	4-20 mA (external 500 ohm resistor)			•		
	Floating			24 Vac		
	2-Position	•	•	•		
Fail Safe Action		Configurable Open / Closed	Configurable Open / Closed	Configurable Open / Closed		
Normal Position		Configurable Open / Closed	Configurable Open / Closed	Configurable Open / Closed		
Aux Switch	Built in					
	Add-On	SW2-US	SW2-US	SW2-US		
Feedback	Built in			2-10 Vdc		
Manual Override				Lever		
Conduit Connection		•	•	•		
Waterproof						
Corrosion-resistant						
Anti-condensate heater						

2-Way Normally Closed (Field-Configurable Normally Open)

Valve Size (inches)	Cv @ 60°	Cv @ 90°	Close-off (psid)	Valve O.S. Number				
2"	61	144	175	VFF2FW1Y2C	VFF2FW1Y2E	VFF2FW1Y2D		
			250				VFF2FW2YLX	VFF2FW2YGX
2 1/2"	107	282	175	VFF2GW1Y2C	VFF2GW1Y2E	VFF2GW1Y2D		
			250				VFF2GW2YLX	VFF2GW2YGX
3"	154	461	175	VFF2HW1Y2C	VFF2HW1Y2E	VFF2HW1Y2D		
			250				VFF2HW2YLX	VFF2HW2YGX
4"	274	841	50	VFF2JV1Y2C	VFF2JV1Y2E	VFF2JV1Y2D		
			175					
			250				VFF2JW2YLX	VFF2JW2YGX
5"	428	1376	50	VFF2KV1Y2C*	VFF2KV1Y2E*	VFF2KV1Y2D*		
			175					
			250				VFF2KW2YLX	VFF2KW2YGX
6"	567	1850	50					
			175					
			250				VFF2LW2YLX	VFF2LW2YGX
8"	1081	3316	50					
			175					
			250				VFF2MW2YLX	VFF2MW2YGX
10"	1710	5430	50					
			175					
			250				VFF2NW2YLX	VFF2NW2YGX
12"	2563	8077	50					
			175					
			250				VFF2PW2YLX	VFF2PW2YGX
14"	3384	10538	50					
			150					
			250					VFF2RW2YGX
16"	4483	13966	50					
			150					
			250					VFF2SW2YGX
18"	5736	17214	50					
			150					
			250					VFF2TW2YGX
20"	7144	22339	50					
			150					
			250				VFF2UW2YGX	

*Chilled water service only.

Resilient Seat Butterfly Valves

3-Way Electrically-Actuated Control

Common Features

- VFF3 – A-B-AB porting, full-cut (150-175 psid close-off) or under-cut disc (50 psid close-off)
- Honeywell direct coupled actuators up to 6" size
- Mixing or diverting control
- Standard right-angle cast-iron T-pipe
- A-port configured to closed position at factory
- Porting pattern field-configurable with valve linkage adjustment
- Resilient Seat Butterfly Valves come with factory-fitted actuators

Actuator Features		Non-fail Safe					
		Floating			Modulating		
Actuator O.S. Number	MN6134A1003	Industrial Actuators			Industrial Actuators		
		NEMA 2	NEMA 4X	NEMA 4	NEMA 2	NEMA 4X	NEMA 4
Power Supply	Voltage	24 Vac	120 Vac	120 Vac	24 Vac	120 Vac	120 Vac
	Frequency	50 / 60 Hz	50 / 60 Hz	50 / 60 Hz	50 / 60 Hz	50 / 60 Hz	50 / 60 Hz
	Power (* tandem mount)	9 / 18* VA	1.4 - 3.0 ALR	3.2 - 4.0 ALR	9 / 18* VA	1.4 - 3.0 ALR	3.2 - 4.0 ALR
Actuator Torque	lb.-in.	300 / 600*	300 - 6,500	8,850 - 31,000	300 / 600*	300 - 6,500	8,850 - 31,000
Control	(0)2-10 Vdc				•	•	•
	4-20 mA (external 500 ohm resistor)				•	In-built	In-built
	Floating	24 Vac	120 Vac	120 Vac	24 Vac		
	2-Position	•	•	•	•		
Fail Safe Action		Stay in Place	Stay in Place	Stay in Place	Stay in Place	Stay in Place	Stay in Place
Normal Position		Configurable Open / Closed	Configurable Open / Closed	Configurable Open / Closed	Configurable Open / Closed	Configurable Open / Closed	Configurable Open / Closed
Aux Switch	Built in		2 x SPDT	2 x SPDT		2 x SPDT	2 x SPDT
	Add-On	SW2-US			SW2-US		
Feedback	Built in				2-10 Vdc	4-20mA / 2-10Vdc	4-20mA / 2-10Vdc
Manual Override			•	•		•	•
Conduit Connection		•	•	•	•	•	•
Waterproof			•	•		•	•
Corrosion-resistant			•	•		•	•
Anti-condensate heater			•	•		•	•



3-Way Mixing / Diverting Globe Valve Porting

Valve Size (inches)	Cv @ 60°	Cv @ 90°	Close-off (psid)	Valve O.S. Number			
2"	61	144	175	VFF3FW1Y2A	VFF3FW1YXA	VFF3FW1Y2B	VFF3FW1YXB
2 1/2"	107	282	175	VFF3GW1Y2A	VFF3GW1YXA	VFF3GW1Y2B	VFF3GW1YXB
3"	154	461	175	VFF3HW1Y2A	VFF3HW1YXA	VFF3HW1Y2B	VFF3HW1YXB
4"	274	841	50	VFF3JV1Y2A	VFF3JV1YXA	VFF3JV1Y2B	VFF3JV1YXB
			175	VFF3JW1Y2A	VFF3JW1YXA	VFF3JW1Y2B	VFF3JW1YXB
5"	428	1376	50	VFF3KW1Y2A*	VFF3KW1YXA	VFF3KW1Y2B*	VFF3KW1YXB
			175	VFF3KW1Y2A	VFF3KW1YXA	VFF3KW1Y2B	VFF3KW1YXB
6"	567	1850	50	VFF3LV1Y2A	VFF3LV1YXA	VFF3LV1Y2B	VFF3LV1YXB
			175	VFF3LW1Y2A	VFF3LW1YXA	VFF3LW1Y2B	VFF3LW1YXB
8"	1081	3316	50	VFF3MV1Y2A	VFF3MV1YXA	VFF3MV1Y2B	VFF3MV1YXB
			175	VFF3MW1Y2A	VFF3MW1YXA	VFF3MW1Y2B	VFF3MW1YXB
10"	1710	5430	50	VFF3NV1Y2A	VFF3NV1YXA	VFF3NV1Y2B	VFF3NV1YXB
			175	VFF3NW1Y2A	VFF3NW1YXA	VFF3NW1Y2B	VFF3NW1YXB
12"	2563	8077	50	VFF3PV1Y2A	VFF3PV1YXA	VFF3PV1Y2B	VFF3PV1YXB
			175	VFF3PW1Y2A	VFF3PW1YXA	VFF3PW1Y2B	VFF3PW1YXB
14"	3384	10538	50	VFF3RV1Y2A	VFF3RV1YXA	VFF3RV1Y2B	VFF3RV1YXB
			150	VFF3RW1Y2A	VFF3RW1YXA	VFF3RW1Y2B	VFF3RW1YXB
16"	4483	13966	50	VFF3SV1Y2A	VFF3SV1YXA	VFF3SV1Y2B	VFF3SV1YXB
			150	VFF3SW1Y2A	VFF3SW1YXA	VFF3SW1Y2B	VFF3SW1YXB
18"	5736	17214	50	VFF3TV1Y2A	VFF3TV1YXA	VFF3TV1Y2B	VFF3TV1YXB
			150	VFF3TW1Y2A	VFF3TW1YXA	VFF3TW1Y2B	VFF3TW1YXB
20"	7144	22339	50	VFF3UV1Y2A	VFF3UV1YXA	VFF3UV1Y2B	VFF3UV1YXB
			150	VFF3UW1Y2A	VFF3UW1YXA	VFF3UW1Y2B	VFF3UW1YXB

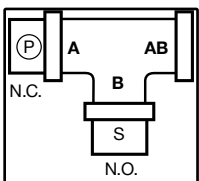

VFF3 Default Configuration

Notes:

Viewed from above

P = Actuator and Primary Valve

S = Slave Valve

VFF3 valve action is mixing for fluid flow from left to right.

VFF3 valve action is diverting for fluid flow from right to left

3-Way Mixing / Diverting Center Common Port

Valve Size (inches)	Cv @ 60°	Cv @ 90°	Close-off (psid)	Valve O.S. Number			
2"	61	144	175	VFF6FW1Y2A	VFF6FW1YXA	VFF6FW1Y2B	VFF6FW1YXB
2 1/2"	107	282	175	VFF6GW1Y2A	VFF6GW1YXA	VFF6GW1Y2B	VFF6GW1YXB
3"	154	461	175	VFF6HW1Y2A	VFF6HW1YXA	VFF6HW1Y2B	VFF6HW1YXB
4"	274	841	50	VFF6JV1Y2A	VFF6JV1YXA	VFF6JV1Y2B	VFF6JV1YXB
			175	VFF6JW1Y2A	VFF6JW1YXA	VFF6JW1Y2B	VFF6JW1YXB
5"	428	1376	50	VFF6KW1Y2A*	VFF6KW1YXA	VFF6KW1Y2B*	VFF6KW1YXB
			175	VFF6KW1Y2A	VFF6KW1YXA	VFF6KW1Y2B	VFF6KW1YXB
6"	567	1850	50	VFF6LV1Y2A	VFF6LV1YXA	VFF6LV1Y2B	VFF6LV1YXB
			175	VFF6LW1Y2A	VFF6LW1YXA	VFF6LW1Y2B	VFF6LW1YXB
8"	1081	3316	50	VFF6MV1Y2A	VFF6MV1YXA	VFF6MV1Y2B	VFF6MV1YXB
			175	VFF6MW1Y2A	VFF6MW1YXA	VFF6MW1Y2B	VFF6MW1YXB
10"	1710	5430	50	VFF6NV1Y2A	VFF6NV1YXA	VFF6NV1Y2B	VFF6NV1YXB
			175	VFF6NW1Y2A	VFF6NW1YXA	VFF6NW1Y2B	VFF6NW1YXB
12"	2563	8077	50	VFF6PV1Y2A	VFF6PV1YXA	VFF6PV1Y2B	VFF6PV1YXB
			175	VFF6PW1Y2A	VFF6PW1YXA	VFF6PW1Y2B	VFF6PW1YXB
14"	3384	10538	50	VFF6RV1Y2A	VFF6RV1YXA	VFF6RV1Y2B	VFF6RV1YXB
			150	VFF6RW1Y2A	VFF6RW1YXA	VFF6RW1Y2B	VFF6RW1YXB
16"	4483	13966	50	VFF6SV1Y2A	VFF6SV1YXA	VFF6SV1Y2B	VFF6SV1YXB
			150	VFF6SW1Y2A	VFF6SW1YXA	VFF6SW1Y2B	VFF6SW1YXB
18"	5736	17214	50	VFF6TV1Y2A	VFF6TV1YXA	VFF6TV1Y2B	VFF6TV1YXB
			150	VFF6TW1Y2A	VFF6TW1YXA	VFF6TW1Y2B	VFF6TW1YXB
20"	7144	22339	50	VFF6UV1Y2A	VFF6UV1YXA	VFF6UV1Y2B	VFF6UV1YXB
			150	VFF6UW1Y2A	VFF6UW1YXA	VFF6UW1Y2B	VFF6UW1YXB

*Chilled water service only.

Resilient Seat Butterfly Valves

3-Way Electrically-Actuated Control

VALVE SELECTION

Actuator Features	Fail Safe			Valve Only End-of-line Service
	2-Position	Modulating		
Actuator O.S. Number	MS8120A1007	MS4120A1001	MS7520A2007	
	NEMA 2	NEMA 2	NEMA 2	
Power Supply	Voltage	24 Vac	100-250 Vac	24 Vac
	Frequency	60 Hz	60 Hz	50 / 60 Hz
Power (* tandem mount)	40 / 80* VA	60 / 120* VA	16 / 32* VA	
Actuator Torque	lb.-in.	175 / 350*	175 / 350*	175 / 350*
Control	(0)2-10 Vdc			•
	4-20 mA (external 500 ohm resistor)			•
Floating			24 Vac	
2-Position	•	•	•	
Fail Safe Action	Configurable Open / Closed	Configurable Open / Closed	Configurable Open / Closed	
Normal Position	Configurable Open / Closed	Configurable Open / Closed	Configurable Open / Closed	
Aux Switch	Built in			
	Add-On	SW2-US	SW2-US	SW2-US
Feedback	Built in			2-10 Vdc
Manual Override				
Conduit Connection	•	•	•	
Waterproof				
Corrosion-resistant				
Anti-condensate heater				

Valve Size (inches)	Cv @ 60°	Cv @ 90°	Close-off (psid)	Valve O.S. Number		
				2"	61	144
2 1/2"	107	282	175	VFF3GW1Y2C	VFF3GW1Y2E	VFF3GW1Y2D
3"	154	461	175	VFF3HW1Y2C	VFF3HW1Y2E	VFF3HW1Y2D
			50	VFF3JV1Y2C	VFF3JV1Y2E	VFF3JV1Y2D
4"	274	841	175			
			50	VFF3KV1Y2C*	VFF3KV1Y2E*	VFF3KV1Y2D*
5"	428	1376	175			
			50			
6"	567	1850	175			
			50			
8"	1081	3316	175			
			50			
10"	1710	5430	175			
			50			
12"	2563	8077	175			
			50			
14"	3384	10538	150			
			50			
16"	4483	13966	150			
			50			
18"	5736	17214	150			
			50			
20"	7144	22339	150			
			50			

Use a pair of 2-way valves with standard flanged Tee

Valve Size (inches)	Cv @ 60°	Cv @ 90°	Close-off (psid)	Valve O.S. Number		
				2"	61	144
2 1/2"	107	282	175	VFF6GW1Y2C	VFF6GW1Y2E	VFF6GW1Y2D
3"	154	461	175	VFF6HW1Y2C	VFF6HW1Y2E	VFF6HW1Y2D
			50	VFF6JV1Y2C	VFF6JV1Y2E	VFF6JV1Y2D
4"	274	841	175			
			50	VFF6KV1Y2C*	VFF6KV1Y2E*	VFF6KV1Y2D*
5"	428	1376	175			
			50			
6"	567	1850	175			
			50			
8"	1081	3316	175			
			50			
10"	1710	5430	175			
			50			
12"	2563	8077	175			
			50			
14"	3384	10538	150			
			50			
16"	4483	13966	150			
			50			
18"	5736	17214	150			
			50			
20"	7144	22339	150			
			50			

Use a pair of 2-way valves with standard flanged Tee

*Chilled water service only.

Resilient Seat Butterfly Valves

3-Way Electrically-Actuated Control

Common Features

- VFF6 – A-AB-B porting, full-cut (150-175 psid close-off) or under-cut disc (50 psid close-off)
- Honeywell direct coupled actuators up to 6" size
- Mixing or diverting control
- Standard right-angle cast-iron T-pipe
- A-port configured to closed position at factory
- Porting pattern field-configurable with valve linkage adjustment
- Resilient Seat Butterfly Valves come with factory-fitted actuators

Actuator Features		Non-fail Safe					
		Floating			Modulating		
Actuator O.S. Number		MN6134A1003	Industrial Actuators		MN7234A2008	Industrial Actuators	
		NEMA 2	NEMA 4X	NEMA 4	NEMA 2	NEMA 4X	NEMA 4
Power Supply	Voltage	24 Vac	120 Vac	120 Vac	24 Vac	120 Vac	120 Vac
	Frequency	50 / 60 Hz	50 / 60 Hz	50 / 60 Hz	50 / 60 Hz	50 / 60 Hz	50 / 60 Hz
Actuator Torque	Power (* tandem mount)	9 / 18* VA	1.4 - 3.0 ALR	3.2 - 4.0 ALR	9 / 18* VA	1.4 - 3.0 ALR	3.2 - 4.0 ALR
	lb.-in.	300 / 600*	300 - 6,500	8,850 - 31,000	300 / 600*	300 - 6,500	8,850 - 31,000
Control	(0)2-10 Vdc				•	•	•
	4-20 mA (external 500 ohm resistor)				•	•	•
	Floating	24 Vac	120 Vac	120 Vac	24 Vac		
	2-Position	•	•	•	•		
Fail Safe Action		Stay in Place	Stay in Place	Stay in Place	Stay in Place	Stay in Place	Stay in Place
Normal Position		Configurable Open / Closed	Configurable Open / Closed	Configurable Open / Closed	Configurable Open / Closed	Configurable Open / Closed	Configurable Open / Closed
Aux Switch	Built in		2 x SPDT	2 x SPDT		2 x SPDT	2 x SPDT
	Add-On	SW2-US			SW2-US		
Feedback	Built in				2-10 Vdc	4-20mA / 2-10Vdc	4-20mA / 2-10Vdc
Manual Override			•	•		•	•
Conduit Connection		•	•	•	•	•	•
Waterproof			•	•		•	•
Corrosion-resistant			•	•		•	•
Anti-condensate heater			•	•		•	•



3-Way Mixing / Diverting Globe Valve Porting

Valve Size (inches)	Cv @ 60°	Cv @ 90°	Close-off (psid)	Valve O.S. Number			
2"	61	144	175	VFF3FW1Y2A	VFF3FW1YXA	VFF3FW1Y2B	VFF3FW1YXB
2 1/2"	107	282	175	VFF3GW1Y2A	VFF3GW1YXA	VFF3GW1Y2B	VFF3GW1YXB
3"	154	461	175	VFF3HW1Y2A	VFF3HW1YXA	VFF3HW1Y2B	VFF3HW1YXB
			50	VFF3JV1Y2A	VFF3JV1YXA	VFF3JV1Y2B	VFF3JV1YXB
4"	274	841	175	VFF3JW1Y2A	VFF3JW1YXA	VFF3JW1Y2B	VFF3JW1YXB
			50	VFF3KW1Y2A*	VFF3KV1YXA	VFF3KW1Y2B*	VFF3KV1YXB
5"	428	1376	175	VFF3KW1Y2A	VFF3KW1YXA	VFF3KW1Y2B	VFF3KW1YXB
			50	VFF3LV1Y2A	VFF3LV1YXA	VFF3LV1Y2B	VFF3LV1YXB
6"	567	1850	175	VFF3LW1Y2A	VFF3LW1YXA	VFF3LW1Y2B	VFF3LW1YXB
			50	VFF3MW1Y2A	VFF3MW1YXA	VFF3MW1Y2B	VFF3MW1YXB
8"	1081	3316	175	VFF3NV1Y2A	VFF3NV1YXA	VFF3NV1Y2B	VFF3NV1YXB
			50	VFF3PW1Y2A	VFF3PW1YXA	VFF3PW1Y2B	VFF3PW1YXB
10"	1710	5430	175	VFF3RV1Y2A	VFF3RV1YXA	VFF3RV1Y2B	VFF3RV1YXB
			50	VFF3RW1Y2A	VFF3RW1YXA	VFF3RW1Y2B	VFF3RW1YXB
12"	2563	8077	175	VFF3SV1Y2A	VFF3SV1YXA	VFF3SV1Y2B	VFF3SV1YXB
			50	VFF3TW1Y2A	VFF3TW1YXA	VFF3TW1Y2B	VFF3TW1YXB
14"	3384	10538	175	VFF3UV1Y2A	VFF3UV1YXA	VFF3UV1Y2B	VFF3UV1YXB
			50	VFF3UW1Y2A	VFF3UW1YXA	VFF3UW1Y2B	VFF3UW1YXB
16"	4483	13966	175	VFF3VW1Y2A	VFF3VW1YXA	VFF3VW1Y2B	VFF3VW1YXB
			50	VFF3XW1Y2A	VFF3XW1YXA	VFF3XW1Y2B	VFF3XW1YXB
18"	5736	17214	175	VFF3YV1Y2A	VFF3YV1YXA	VFF3YV1Y2B	VFF3YV1YXB
			50	VFF3YV1Y2A	VFF3YV1YXA	VFF3YV1Y2B	VFF3YV1YXB
20"	7144	22339	175	VFF3ZV1Y2A	VFF3ZV1YXA	VFF3ZV1Y2B	VFF3ZV1YXB
			50	VFF3ZV1Y2A	VFF3ZV1YXA	VFF3ZV1Y2B	VFF3ZV1YXB

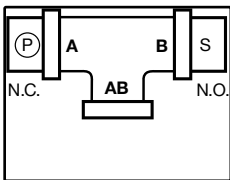

VFF6 Default Configuration

Notes:

Viewed from above

P = Actuator and Primary Valve

S = Slave Valve

VFF6 may be piped for mixing control with water exiting port AB, or for diverting control with water entering port AB

3-Way Mixing / Diverting Center Common Port

Valve Size (inches)	Cv @ 60°	Cv @ 90°	Close-off (psid)	Valve O.S. Number			
2"	61	144	175	VFF6FW1Y2A	VFF6FW1YXA	VFF6FW1Y2B	VFF6FW1YXB
2 1/2"	107	282	175	VFF6GW1Y2A	VFF6GW1YXA	VFF6GW1Y2B	VFF6GW1YXB
3"	154	461	175	VFF6HW1Y2A	VFF6HW1YXA	VFF6HW1Y2B	VFF6HW1YXB
			50	VFF6JV1Y2A	VFF6JV1YXA	VFF6JV1Y2B	VFF6JV1YXB
4"	274	841	175	VFF6JW1Y2A	VFF6JW1YXA	VFF6JW1Y2B	VFF6JW1YXB
			50	VFF6KW1Y2A*	VFF6KV1YXA	VFF6KW1Y2B*	VFF6KV1YXB
5"	428	1376	175	VFF6KW1Y2A	VFF6KW1YXA	VFF6KW1Y2B	VFF6KW1YXB
			50	VFF6LV1Y2A	VFF6LV1YXA	VFF6LV1Y2B	VFF6LV1YXB
6"	567	1850	175	VFF6LW1Y2A	VFF6LW1YXA	VFF6LW1Y2B	VFF6LW1YXB
			50	VFF6MW1Y2A	VFF6MW1YXA	VFF6MW1Y2B	VFF6MW1YXB
8"	1081	3316	175	VFF6NV1Y2A	VFF6NV1YXA	VFF6NV1Y2B	VFF6NV1YXB
			50	VFF6PW1Y2A	VFF6PW1YXA	VFF6PW1Y2B	VFF6PW1YXB
10"	1710	5430	175	VFF6RV1Y2A	VFF6RV1YXA	VFF6RV1Y2B	VFF6RV1YXB
			50	VFF6RW1Y2A	VFF6RW1YXA	VFF6RW1Y2B	VFF6RW1YXB
12"	2563	8077	175	VFF6SV1Y2A	VFF6SV1YXA	VFF6SV1Y2B	VFF6SV1YXB
			50	VFF6TW1Y2A	VFF6TW1YXA	VFF6TW1Y2B	VFF6TW1YXB
14"	3384	10538	175	VFF6UV1Y2A	VFF6UV1YXA	VFF6UV1Y2B	VFF6UV1YXB
			50	VFF6UW1Y2A	VFF6UW1YXA	VFF6UW1Y2B	VFF6UW1YXB
16"	4483	13966	175	VFF6VW1Y2A	VFF6VW1YXA	VFF6VW1Y2B	VFF6VW1YXB
			50	VFF6XW1Y2A	VFF6XW1YXA	VFF6XW1Y2B	VFF6XW1YXB
18"	5736	17214	175	VFF6YV1Y2A	VFF6YV1YXA	VFF6YV1Y2B	VFF6YV1YXB
			50	VFF6YV1Y2A	VFF6YV1YXA	VFF6YV1Y2B	VFF6YV1YXB
20"	7144	22339	175	VFF6ZV1Y2A	VFF6ZV1YXA	VFF6ZV1Y2B	VFF6ZV1YXB
			50	VFF6ZV1Y2A	VFF6ZV1YXA	VFF6ZV1Y2B	VFF6ZV1YXB

*Chilled water service only.

Resilient Seat Butterfly Valves

3-Way Electrically-Actuated Control

VALVE SELECTION

Actuator Features	Fail Safe			Valve Only End-of-line Service
	2-Position	Modulating		
Actuator O.S. Number	MS8120A1007	MS4120A1001	MS7520A2007	
	NEMA 2	NEMA 2	NEMA 2	
Power Supply	Voltage	24 Vac	100-250 Vac	24 Vac
	Frequency	60 Hz	60 Hz	50 / 60 Hz
Power (* tandem mount)	40 / 80* VA	60 / 120* VA	16 / 32* VA	
Actuator Torque	lb.-in.	175 / 350*	175 / 350*	175 / 350*
Control	(0)2-10 Vdc			•
	4-20 mA (external 500 ohm resistor)			•
Floating			24 Vac	
2-Position	•	•	•	
Fail Safe Action	Configurable Open / Closed	Configurable Open / Closed	Configurable Open / Closed	
Normal Position	Configurable Open / Closed	Configurable Open / Closed	Configurable Open / Closed	
Aux Switch	Built in			
	Add-On	SW2-US	SW2-US	SW2-US
Feedback	Built in			2-10 Vdc
Manual Override				
Conduit Connection	•	•	•	
Waterproof				
Corrosion-resistant				
Anti-condensate heater				

Valve Size (inches)	Cv @ 60°	Cv @ 90°	Close-off (psid)	Valve O.S. Number		
				2"	61	144
2 1/2"	107	282	175	VFF3GW1Y2C	VFF3GW1Y2E	VFF3GW1Y2D
3"	154	461	175	VFF3HW1Y2C	VFF3HW1Y2E	VFF3HW1Y2D
4"	274	841	50	VFF3JV1Y2C	VFF3JV1Y2E	VFF3JV1Y2D
			175			
5"	428	1376	50	VFF3KV1Y2C*	VFF3KV1Y2E*	VFF3KV1Y2D*
			175			
6"	567	1850	50			
			175			
8"	1081	3316	50			
			175			
10"	1710	5430	50			
			175			
12"	2563	8077	50			
			175			
14"	3384	10538	50			
			150			
16"	4483	13966	50			
			150			
18"	5736	17214	50			
			150			
20"	7144	22339	50			
			150			

Use a pair of 2-way valves with standard flanged Tee

Valve Size (inches)	Cv @ 60°	Cv @ 90°	Close-off (psid)	Valve O.S. Number		
				2"	61	144
2 1/2"	107	282	175	VFF6GW1Y2C	VFF6GW1Y2E	VFF6GW1Y2D
3"	154	461	175	VFF6HW1Y2C	VFF6HW1Y2E	VFF6HW1Y2D
4"	274	841	50	VFF6JV1Y2C	VFF6JV1Y2E	VFF6JV1Y2D
			175			
5"	428	1376	50	VFF6KV1Y2C*	VFF6KV1Y2E*	VFF6KV1Y2D*
			175			
6"	567	1850	50			
			175			
8"	1081	3316	50			
			175			
10"	1710	5430	50			
			175			
12"	2563	8077	50			
			175			
14"	3384	10538	50			
			150			
16"	4483	13966	50			
			150			
18"	5736	17214	50			
			150			
20"	7144	22339	50			
			150			

Use a pair of 2-way valves with standard flanged Tee

*Chilled water service only.

Resilient Seat Butterfly Valves

2-Way Pneumatically-Actuated Control

Common Features

Honeywell offers a wide selection of pneumatic actuators:

- 20 psi spring return (up to 10" size)
- 80 psi spring return
- 80 psi double acting bi-directional

Configurable with accessories:

- Positioner
- Electro-pneumatic positioner (80 psi only)
- Electro-pneumatic solenoid (80 psi only)
- VFF1 configured normally open and VFF2 normally closed at factory for spring return actuators
- Body style: lugged butterfly valve with full-cut (150-175 psid close-off) or under-cut disc (50 psid close-off)
- Bi-directional actuator 175 psid close-off on all sizes with full cut disc (2-way only)
- Normally-open configuration (VFF1 spring return)
- Normally-closed configuration (VFF2 spring return)



Actuator Features		Non-fail Safe (Bidirectional)				
Actuator		80 psi Actuator				
Power Supply	Voltage	Standard	E-P Solenoid	E-P Solenoid	Positioner	E-P Positioner
	Frequency		24 Vac	120 VAc		24 Vac
	Power		50 / 60 Hz	50 / 60 Hz		50 / 60 Hz
	Power		6 W	6 W		
Control	Modulating Pneumatic					
	2-Position		•	•		
	4-20 mA					•
Auxiliary Switch	Add-On	VFF50-0400	VFF50-0400	VFF50-0400		
Manual Override		•				
Conduit Connection			•	•		•
Waterproof						•
Fail Safe						

Valve Size (inches)	Cv @ 60°	Cv @ 90°	Close-off (psid)	Valve O.S. Number				
				VFF2FW1YXR	VFF2FW1YCR	VFF2FW1YER	VFF2FW1YPR	VFF2FW1YDR
2"	61	144	175					
2 1/2"	107	282	175					
3"	154	461	175					
4"	274	841	50					
			175					
5"	428	1376	50					
			175					
6"	567	1850	50					
			175					
8"	1081	3316	50					
			175					
10"	1710	5430	50					
			175					
12"	2563	8077	50					
			175					
14"	3384	10538	50					
			150*					
16"	4483	13966	50					
			150*					
18"	5736	17214	50					
			150*					
20"	7144	22339	50					
			150*					
				Use VFF2 models for Bi-directional pneumatic operation				
Valve Size (inches)	Cv @ 60°	Cv @ 90°	Close-off (psid)	Valve O.S. Number				
2"	61	144	175	VFF2FW1YXR	VFF2FW1YCR	VFF2FW1YER	VFF2FW1YPR	VFF2FW1YDR
2 1/2"	107	282	175	VFF2GW1YXR	VFF2GW1YCR	VFF2GW1YER	VFF2GW1YPR	VFF2GW1YDR
3"	154	461	175	VFF2HW1YXR	VFF2HW1YCR	VFF2HW1YER	VFF2HW1YPR	VFF2HW1YDR
4"	274	841	50	VFF2JV1YXR	VFF2JV1YCR	VFF2JV1YER	VFF2JV1YPR	VFF2JV1YDR
			175	VFF2JW1YXR	VFF2JW1YCR	VFF2JW1YER	VFF2JW1YPR	VFF2JW1YDR
5"	428	1376	50	VFF2KV1YXR	VFF2KV1YCR	VFF2KV1YER	VFF2KV1YPR	VFF2KV1YDR
			175	VFF2KW1YXR	VFF2KW1YCR	VFF2KW1YER	VFF2KW1YPR	VFF2KW1YDR
6"	567	1850	50	VFF2LV1YXR	VFF2LV1YCR	VFF2LV1YER	VFF2LV1YPR	VFF2LV1YDR
			175	VFF2LW1YXR	VFF2LW1YCR	VFF2LW1YER	VFF2LW1YPR	VFF2LW1YDR
8"	1081	3316	50	VFF2MV1YXR	VFF2MV1YCR	VFF2MV1YER	VFF2MV1YPR	VFF2MV1YDR
			175	VFF2MW1YXR	VFF2MW1YCR	VFF2MW1YER	VFF2MW1YPR	VFF2MW1YDR
10"	1710	5430	50	VFF2NV1YXR	VFF2NV1YCR	VFF2NV1YER	VFF2NV1YPR	VFF2NV1YDR
			175	VFF2NW1YXR	VFF2NW1YCR	VFF2NW1YER	VFF2NW1YPR	VFF2NW1YDR
12"	2563	8077	50	VFF2PV1YXR	VFF2PV1YCR	VFF2PV1YER	VFF2PV1YPR	VFF2PV1YDR
			175	VFF2PW1YXR	VFF2PW1YCR	VFF2PW1YER	VFF2PW1YPR	VFF2PW1YDR
14"	3384	10538	50	VFF2RV1YXR	VFF2RV1YCR	VFF2RV1YER	VFF2RV1YPR	VFF2RV1YDR
			175*	VFF2RW1YXR	VFF2RW1YCR	VFF2RW1YER	VFF2RW1YPR	VFF2RW1YDR
16"	4483	13966	50	VFF2SV1YXR	VFF2SV1YCR	VFF2SV1YER	VFF2SV1YPR	VFF2SV1YDR
			175*	VFF2SW1YXR	VFF2SW1YCR	VFF2SW1YER	VFF2SW1YPR	VFF2SW1YDR
18"	5736	17214	50	VFF2TV1YXR	VFF2TV1YCR	VFF2TV1YER	VFF2TV1YPR	VFF2TV1YDR
			175*	VFF2TW1YXR	VFF2TW1YCR	VFF2TW1YER	VFF2TW1YPR	VFF2TW1YDR
20"	7144	22339	50	VFF2UV1YXR	VFF2UV1YCR	VFF2UV1YER	VFF2UV1YPR	VFF2UV1YDR
			175*	VFF2UW1YXR	VFF2UW1YCR	VFF2UW1YER	VFF2UW1YPR	VFF2UW1YDR

* Full cut valves with bi-directional pneumatic actuators feature 175 psi close-off in all body sizes

Resilient Seat Butterfly Valves

2-Way Pneumatically-Actuated Control

VALVE SELECTION

Actuator Features		Fail Safe						
Actuator		20 psi Actuator			80 psi Actuator			
		8-13 spring	Positioner	Standard	E-P Solenoid	E-P Solenoid	Positioner	E-P Positioner
Power Supply	Voltage				24 Vac	120 Vac		24 Vac
	Frequency				50 / 60 Hz	50 / 60 Hz		50 / 60 Hz
	Power				6 W	6 W		
Control	Modulating Pneumatic	•	•	•			•	
	2-Position				•	•		
	4-20 mA							•
Auxiliary Switch	Add-On			VFF50-0400	VFF50-0400	VFF50-0400		
Manual Override				•				
Conduit Connection					•	•		•
Waterproof								•
Fail Safe		•	•	•	•	•	•	•

Valve Size (inches)	Cv @ 60°	Cv @ 90°	Close-off (psid)	Valve O.S. Number							
2"	61	144	175	VFF1FW1Y8P	VFF1FW1YPP	VFF1FW1YXS	VFF1FW1YCS	VFF1FW1YES	VFF1FW1YPS	VFF1FW1YDS	
2 1/2"	107	282	175	VFF1GW1Y8P	VFF1GW1YPP	VFF1GW1YXS	VFF1GW1YCS	VFF1GW1YES	VFF1GW1YPS	VFF1GW1YDS	
3"	154	461	175	VFF1HW1Y8P	VFF1HW1YPP	VFF1HW1YXS	VFF1HW1YCS	VFF1HW1YES	VFF1HW1YPS	VFF1HW1YDS	
			50	VFF1JV1Y8P	VFF1JV1YPP	VFF1JV1YXS	VFF1JV1YCS	VFF1JV1YES	VFF1JV1YPS	VFF1JV1YDS	
4"	274	841	175	VFF1JW1Y8P	VFF1JW1YPP	VFF1JW1YXS	VFF1JW1YCS	VFF1JW1YES	VFF1JW1YPS	VFF1JW1YDS	
			50	VFF1KV1Y8P	VFF1KV1YPP	VFF1KV1YXS	VFF1KV1YCS	VFF1KV1YES	VFF1KV1YPS	VFF1KV1YDS	
5"	428	1376	175	VFF1KW1Y8P	VFF1KW1YPP	VFF1KW1YXS	VFF1KW1YCS	VFF1KW1YES	VFF1KW1YPS	VFF1KW1YDS	
			50	VFF1LW1Y8P	VFF1LW1YPP*	VFF1LW1YXS	VFF1LW1YCS	VFF1LW1YES	VFF1LW1YPS	VFF1LW1YDS	
6"	567	1850	175	VFF1LW1Y8P	VFF1LW1YPP	VFF1LW1YXS	VFF1LW1YCS	VFF1LW1YES	VFF1LW1YPS	VFF1LW1YDS	
			50	VFF1MW1Y8P	VFF1MW1YPP	VFF1MW1YXS	VFF1MW1YCS	VFF1MW1YES	VFF1MW1YPS	VFF1MW1YDS	
8"	1081	3316	175	VFF1MW1Y8P	VFF1MW1YPP	VFF1MW1YXS	VFF1MW1YCS	VFF1MW1YES	VFF1MW1YPS	VFF1MW1YDS	
			50	VFF1NV1Y8P	VFF1NV1YPP	VFF1NV1YXS	VFF1NV1YCS	VFF1NV1YES	VFF1NV1YPS	VFF1NV1YDS	
10"	1710	5430	175			VFF1NW1YXS	VFF1NW1YCS	VFF1NW1YES	VFF1NW1YPS	VFF1NW1YDS	
			50			VFF1PV1YXS	VFF1PV1YCS	VFF1PV1YES	VFF1PV1YPS	VFF1PV1YDS	
12"	2563	8077	175			VFF1PW1YXS	VFF1PW1YCS	VFF1PW1YES	VFF1PW1YPS	VFF1PW1YDS	
			50			VFF1RV1YXS	VFF1RV1YCS	VFF1RV1YES	VFF1RV1YPS	VFF1RV1YDS	
14"	3384	10538	150			VFF1RW1YXS	VFF1RW1YCS	VFF1RW1YES	VFF1RW1YPS	VFF1RW1YDS	
			50			VFF1SV1YXS	VFF1SV1YCS	VFF1SV1YES	VFF1SV1YPS	VFF1SV1YDS	
16"	4483	13966	150			VFF1SW1YXS	VFF1SW1YCS	VFF1SW1YES	VFF1SW1YPS	VFF1SW1YDS	
			50			VFF1TV1YXS	VFF1TV1YCS	VFF1TV1YES	VFF1TV1YPS	VFF1TV1YDS	
18"	5736	17214	150			VFF1TW1YXS	VFF1TW1YCS	VFF1TW1YES	VFF1TW1YPS	VFF1TW1YDS	
			50			VFF1UV1YXS	VFF1UV1YCS	VFF1UV1YES	VFF1UV1YPS	VFF1UV1YDS	
20"	7144	22339	150			VFF1UW1YXS	VFF1UW1YCS	VFF1UW1YES	VFF1UW1YPS	VFF1UW1YDS	
			150								
Valve Size (inches)	Cv @ 60°	Cv @ 90°	Close-off (psid)	Valve O.S. Number							
2"	61	144	175	VFF2FW1Y8P	VFF2FW1YPP	VFF2FW1YXS	VFF2FW1YCS	VFF2FW1YES	VFF2FW1YPS	VFF2FW1YDS	
2 1/2"	107	282	175	VFF2GW1Y8P	VFF2GW1YPP	VFF2GW1YXS	VFF2GW1YCS	VFF2GW1YES	VFF2GW1YPS	VFF2GW1YDS	
3"	154	461	175	VFF2HW1Y8P	VFF2HW1YPP	VFF2HW1YXS	VFF2HW1YCS	VFF2HW1YES	VFF2HW1YPS	VFF2HW1YDS	
			50	VFF2JV1Y8P	VFF2JV1YPP	VFF2JV1YXS	VFF2JV1YCS	VFF2JV1YES	VFF2JV1YPS	VFF2JV1YDS	
4"	274	841	175	VFF2JW1Y8P	VFF2JW1YPP	VFF2JW1YXS	VFF2JW1YCS	VFF2JW1YES	VFF2JW1YPS	VFF2JW1YDS	
			50	VFF2KV1Y8P	VFF2KV1YPP	VFF2KV1YXS	VFF2KV1YCS	VFF2KV1YES	VFF2KV1YPS	VFF2KV1YDS	
5"	428	1376	175	VFF2KW1Y8P	VFF2KW1YPP	VFF2KW1YXS	VFF2KW1YCS	VFF2KW1YES	VFF2KW1YPS	VFF2KW1YDS	
			50	VFF2LW1Y8P	VFF2LW1YPP*	VFF2LW1YXS	VFF2LW1YCS	VFF2LW1YES	VFF2LW1YPS	VFF2LW1YDS	
6"	567	1850	175	VFF2LW1Y8P	VFF2LW1YPP	VFF2LW1YXS	VFF2LW1YCS	VFF2LW1YES	VFF2LW1YPS	VFF2LW1YDS	
			50	VFF2MV1Y8P	VFF2MV1YPP	VFF2MV1YXS	VFF2MV1YCS	VFF2MV1YES	VFF2MV1YPS	VFF2MV1YDS	
8"	1081	3316	175	VFF2MW1Y8P	VFF2MW1YPP	VFF2MW1YXS	VFF2MW1YCS	VFF2MW1YES	VFF2MW1YPS	VFF2MW1YDS	
			50	VFF2NV1Y8P	VFF2NV1YPP	VFF2NV1YXS	VFF2NV1YCS	VFF2NV1YES	VFF2NV1YPS	VFF2NV1YDS	
10"	1710	5430	175			VFF2NW1YXS	VFF2NW1YCS	VFF2NW1YES	VFF2NW1YPS	VFF2NW1YDS	
			50			VFF2PV1YXS	VFF2PV1YCS	VFF2PV1YES	VFF2PV1YPS	VFF2PV1YDS	
12"	2563	8077	175			VFF2PW1YXS	VFF2PW1YCS	VFF2PW1YES	VFF2PW1YPS	VFF2PW1YDS	
			50			VFF2RV1YXS	VFF2RV1YCS	VFF2RV1YES	VFF2RV1YPS	VFF2RV1YDS	
14"	3384	10538	150			VFF2RW1YXS	VFF2RW1YCS	VFF2RW1YES	VFF2RW1YPS	VFF2RW1YDS	
			50			VFF2SV1YXS	VFF2SV1YCS	VFF2SV1YES	VFF2SV1YPS	VFF2SV1YDS	
16"	4483	13966	150			VFF2SW1YXS	VFF2SW1YCS	VFF2SW1YES	VFF2SW1YPS	VFF2SW1YDS	
			50			VFF2TV1YXS	VFF2TV1YCS	VFF2TV1YES	VFF2TV1YPS	VFF2TV1YDS	
18"	5736	17214	150			VFF2TW1YXS	VFF2TW1YCS	VFF2TW1YES	VFF2TW1YPS	VFF2TW1YDS	
			50			VFF2UV1YXS	VFF2UV1YCS	VFF2UV1YES	VFF2UV1YPS	VFF2UV1YDS	
20"	7144	22339	150			VFF2UW1YXS	VFF2UW1YCS	VFF2UW1YES	VFF2UW1YPS	VFF2UW1YDS	
			150								

*Use full cut, 175psid close-off valves - No under-cut, 50psid close-off valve available

Resilient Seat Butterfly Valves

3-Way Pneumatically-Actuated Control

Common Features

Honeywell offers a wide selection of pneumatic actuators:

- VFF3 – A-B-AB porting, full-cut (150-175 psid close-off) or under-cut disc (50 psid close-off) (Figure 1 - from 63-2661-02 fig. 12)
- VFF6 – A-AB-B porting, full-cut (150-175 psid close-off) or under-cut disc (50 psid close-off) (Figure 2 - from 63-2661-02 fig. 12)
- 20 psi spring return (up to 8" size)
- 80 psi spring return
- 80 psi double acting bi-directional
- Mixing or diverting control
- Standard right-angle cast-iron T-pipe
- A-port configured to closed position at factory
- Porting pattern field-configurable with valve linkage adjustment

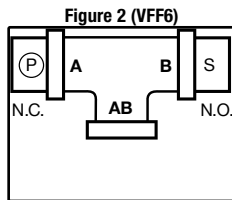
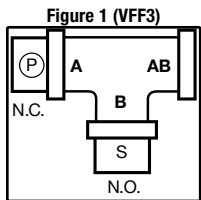

Notes:

Viewed from above

P = Actuator and Primary Valve

S = Slave Valve

VFF3 valve action is mixing for fluid flow from left to right.

VFF3 valve action is diverting for fluid flow from right to left

VFF6 may be piped for mixing control with water exiting port AB, or for diverting control with water entering port AB

Actuator Features		Non-fail Safe (Bidirectional)				
Actuator		80 psi Actuator				
Power Supply		Standard	E-P Solenoid	E-P Solenoid	Positioner	E-P Positioner
Voltage			24 Vac	120 VAc		24 Vac
Frequency			50 / 60 Hz	50 / 60 Hz		50 / 60 Hz
Power			6 W	6 W		
Control						
Modulating Pneumatic		•			•	
2-Position			•	•		
4-20 mA						•
Auxiliary Switch		VFF50-0400	VFF50-0400	VFF50-0400		
Manual Override		•				
Conduit Connection			•	•		•
Waterproof						•
Fail Safe						

Valve Size (inches)	Cv @ 60°	Cv @ 90°	Close-off (psid)	Valve O.S. Number				
				Use VFF2 models for Bi-directional pneumatic operation				
2"	61	144	175					
2 1/2"	107	282	175					
3"	154	461	175					
4"	274	841	50					
			175					
5"	428	1376	50					
			175					
6"	567	1850	50					
			175					
8"	1081	3316	50					
			175					
10"	1710	5430	50					
			175					
12"	2563	8077	50					
			175					
14"	3384	10538	50					
			150					
16"	4483	13966	50					
			150					
18"	5736	17214	50					
			150					
20"	7144	22339	50					
			150					

Valve Size (inches)	Cv @ 60°	Cv @ 90°	Close-off (psid)	Valve O.S. Number				
				VFF2FW1YXR	VFF2FW1YCR	VFF2FW1YER	VFF2FW1YPR	VFF2FW1YDR
2"	61	144	175	VFF2FW1YXR	VFF2FW1YCR	VFF2FW1YER	VFF2FW1YPR	VFF2FW1YDR
2 1/2"	107	282	175	VFF2GW1YXR	VFF2GW1YCR	VFF2GW1YER	VFF2GW1YPR	VFF2GW1YDR
3"	154	461	175	VFF2HW1YXR	VFF2HW1YCR	VFF2HW1YER	VFF2HW1YPR	VFF2HW1YDR
4"	274	841	50	VFF2JV1YXR	VFF2JV1YCR	VFF2JV1YER	VFF2JV1YPR	VFF2JV1YDR
			175	VFF2JW1YXR	VFF2JW1YCR	VFF2JW1YER	VFF2JW1YPR	VFF2JW1YDR
5"	428	1376	50	VFF2KV1YXR	VFF2KV1YCR	VFF2KV1YER	VFF2KV1YPR	VFF2KV1YDR
			175	VFF2KW1YXR	VFF2KW1YCR	VFF2KW1YER	VFF2KW1YPR	VFF2KW1YDR
6"	567	1850	50	VFF2LV1YXR	VFF2LV1YCR	VFF2LV1YER	VFF2LV1YPR	VFF2LV1YDR
			175	VFF2LW1YXR	VFF2LW1YCR	VFF2LW1YER	VFF2LW1YPR	VFF2LW1YDR
8"	1081	3316	50	VFF2MV1YXR	VFF2MV1YCR	VFF2MV1YER	VFF2MV1YPR	VFF2MV1YDR
			175	VFF2MW1YXR	VFF2MW1YCR	VFF2MW1YER	VFF2MW1YPR	VFF2MW1YDR
10"	1710	5430	50	VFF2NV1YXR	VFF2NV1YCR	VFF2NV1YER	VFF2NV1YPR	VFF2NV1YDR
			175	VFF2NW1YXR	VFF2NW1YCR	VFF2NW1YER	VFF2NW1YPR	VFF2NW1YDR
12"	2563	8077	50	VFF2PV1YXR	VFF2PV1YCR	VFF2PV1YER	VFF2PV1YPR	VFF2PV1YDR
			175	VFF2PW1YXR	VFF2PW1YCR	VFF2PW1YER	VFF2PW1YPR	VFF2PW1YDR
14"	3384	10538	50	VFF2RV1YXR	VFF2RV1YCR	VFF2RV1YER	VFF2RV1YPR	VFF2RV1YDR
			175*	VFF2RW1YXR	VFF2RW1YCR	VFF2RW1YER	VFF2RW1YPR	VFF2RW1YDR
16"	4483	13966	50	VFF2SV1YXR	VFF2SV1YCR	VFF2SV1YER	VFF2SV1YPR	VFF2SV1YDR
			175*	VFF2SW1YXR	VFF2SW1YCR	VFF2SW1YER	VFF2SW1YPR	VFF2SW1YDR
18"	5736	17214	50	VFF2TV1YXR	VFF2TV1YCR	VFF2TV1YER	VFF2TV1YPR	VFF2TV1YDR
			175*	VFF2TW1YXR	VFF2TW1YCR	VFF2TW1YER	VFF2TW1YPR	VFF2TW1YDR
20"	7144	22339	50	VFF2UV1YXR	VFF2UV1YCR	VFF2UV1YER	VFF2UV1YPR	VFF2UV1YDR
			175*	VFF2UW1YXR	VFF2UW1YCR	VFF2UW1YER	VFF2UW1YPR	VFF2UW1YDR

* Full cut valves with bi-directional pneumatic actuators feature 175 psi close-off in all body sizes

Resilient Seat Butterfly Valves

3-Way Pneumatically-Actuated Control

VALVE SELECTION

Actuator Features		Fail Safe						
Actuator		20 psi Actuator			80 psi Actuator			
		8-13 spring	Positioner	Standard	E-P Solenoid	E-P Solenoid	Positioner	E-P Positioner
Power Supply	Voltage				24 Vac	120 Vac		24 Vac
	Frequency				50 / 60 Hz	50 / 60 Hz		50 / 60 Hz
	Power				6 W	6 W		
Control	Modulating Pneumatic	•	•	•			•	
	2-Position				•	•		
	4-20 mA							•
Auxiliary Switch	Add-On			VFF50-0400	VFF50-0400	VFF50-0400		
Manual Override				•				
Conduit Connection					•	•		•
Waterproof								•
Fail Safe		•	•	•	•	•	•	•

Valve Size (inches)	Cv @ 60°	Cv @ 90°	Close-off (psid)	Valve O.S. Number							
				2"	61	144	175	VFF1FW1Y8P	VFF1FW1YPP	VFF1FW1YXS	VFF1FW1YCS
2 1/2"	107	282	175	VFF1GW1Y8P	VFF1GW1YPP	VFF1GW1YXS	VFF1GW1YCS	VFF1GW1YES	VFF1GW1YPS	VFF1GW1YDS	
3"	154	461	175	VFF1HW1Y8P	VFF1HW1YPP	VFF1HW1YXS	VFF1HW1YCS	VFF1HW1YES	VFF1HW1YPS	VFF1HW1YDS	
			50	VFF1JV1Y8P	VFF1JV1YPP	VFF1JV1YXS	VFF1JV1YCS	VFF1JV1YES	VFF1JV1YPS	VFF1JV1YDS	
4"	274	841	175	VFF1JW1Y8P	VFF1JW1YPP	VFF1JW1YXS	VFF1JW1YCS	VFF1JW1YES	VFF1JW1YPS	VFF1JW1YDS	
			50	VFF1KV1Y8P	VFF1KV1YPP	VFF1KV1YXS	VFF1KV1YCS	VFF1KV1YES	VFF1KV1YPS	VFF1KV1YDS	
5"	428	1376	175	VFF1KW1Y8P	VFF1KW1YPP	VFF1KW1YXS	VFF1KW1YCS	VFF1KW1YES	VFF1KW1YPS	VFF1KW1YDS	
			50	VFF1LW1Y8P*	VFF1LW1YPP*	VFF1LV1YXS	VFF1LV1YCS	VFF1LV1YES	VFF1LV1YPS	VFF1LV1YDS	
6"	567	1850	175	VFF1LW1Y8P	VFF1LW1YPP	VFF1LW1YXS	VFF1LW1YCS	VFF1LW1YES	VFF1LW1YPS	VFF1LW1YDS	
			50	VFF1MV1Y8P	VFF1MV1YPP	VFF1MV1YXS	VFF1MV1YCS	VFF1MV1YES	VFF1MV1YPS	VFF1MV1YDS	
8"	1081	3316	175	VFF1MW1Y8P	VFF1MW1YPP	VFF1MW1YXS	VFF1MW1YCS	VFF1MW1YES	VFF1MW1YPS	VFF1MW1YDS	
			50	VFF1NV1Y8P	VFF1NV1YPP	VFF1NV1YXS	VFF1NV1YCS	VFF1NV1YES	VFF1NV1YPS	VFF1NV1YDS	
10"	1710	5430	175			VFF1NW1YXS	VFF1NW1YCS	VFF1NW1YES	VFF1NW1YPS	VFF1NW1YDS	
			50			VFF1PV1YXS	VFF1PV1YCS	VFF1PV1YES	VFF1PV1YPS	VFF1PV1YDS	
12"	2563	8077	175			VFF1PW1YXS	VFF1PW1YCS	VFF1PW1YES	VFF1PW1YPS	VFF1PW1YDS	
			50			VFF1RV1YXS	VFF1RV1YCS	VFF1RV1YES	VFF1RV1YPS	VFF1RV1YDS	
14"	3384	10538	150			VFF1RW1YXS	VFF1RW1YCS	VFF1RW1YES	VFF1RW1YPS	VFF1RW1YDS	
			50			VFF1SV1YXS	VFF1SV1YCS	VFF1SV1YES	VFF1SV1YPS	VFF1SV1YDS	
16"	4483	13966	150			VFF1SW1YXS	VFF1SW1YCS	VFF1SW1YES	VFF1SW1YPS	VFF1SW1YDS	
			50			VFF1TV1YXS	VFF1TV1YCS	VFF1TV1YES	VFF1TV1YPS	VFF1TV1YDS	
18"	5736	17214	150			VFF1TW1YXS	VFF1TW1YCS	VFF1TW1YES	VFF1TW1YPS	VFF1TW1YDS	
			50			VFF1UV1YXS	VFF1UV1YCS	VFF1UV1YES	VFF1UV1YPS	VFF1UV1YDS	
20"	7144	22339	150			VFF1UW1YXS	VFF1UW1YCS	VFF1UW1YES	VFF1UW1YPS	VFF1UW1YDS	

Valve Size (inches)	Cv @ 60°	Cv @ 90°	Close-off (psid)	Valve O.S. Number							
				2"	61	144	175	VFF2FW1Y8P	VFF2FW1YPP	VFF2FW1YXS	VFF2FW1YCS
2 1/2"	107	282	175	VFF2GW1Y8P	VFF2GW1YPP	VFF2GW1YXS	VFF2GW1YCS	VFF2GW1YES	VFF2GW1YPS	VFF2GW1YDS	
3"	154	461	175	VFF2HW1Y8P	VFF2HW1YPP	VFF2HW1YXS	VFF2HW1YCS	VFF2HW1YES	VFF2HW1YPS	VFF2HW1YDS	
			50	VFF2JV1Y8P	VFF2JV1YPP	VFF2JV1YXS	VFF2JV1YCS	VFF2JV1YES	VFF2JV1YPS	VFF2JV1YDS	
4"	274	841	175	VFF2JW1Y8P	VFF2JW1YPP	VFF2JW1YXS	VFF2JW1YCS	VFF2JW1YES	VFF2JW1YPS	VFF2JW1YDS	
			50	VFF2KV1Y8P	VFF2KV1YPP	VFF2KV1YXS	VFF2KV1YCS	VFF2KV1YES	VFF2KV1YPS	VFF2KV1YDS	
5"	428	1376	175	VFF2KW1Y8P	VFF2KW1YPP	VFF2KW1YXS	VFF2KW1YCS	VFF2KW1YES	VFF2KW1YPS	VFF2KW1YDS	
			50	VFF2LW1Y8P*	VFF2LW1YPP*	VFF2LV1YXS	VFF2LV1YCS	VFF2LV1YES	VFF2LV1YPS	VFF2LV1YDS	
6"	567	1850	175	VFF2LW1Y8P	VFF2LW1YPP	VFF2LW1YXS	VFF2LW1YCS	VFF2LW1YES	VFF2LW1YPS	VFF2LW1YDS	
			50	VFF2MV1Y8P	VFF2MV1YPP	VFF2MV1YXS	VFF2MV1YCS	VFF2MV1YES	VFF2MV1YPS	VFF2MV1YDS	
8"	1081	3316	175	VFF2MW1Y8P	VFF2MW1YPP	VFF2MW1YXS	VFF2MW1YCS	VFF2MW1YES	VFF2MW1YPS	VFF2MW1YDS	
			50	VFF2NV1Y8P	VFF2NV1YPP	VFF2NV1YXS	VFF2NV1YCS	VFF2NV1YES	VFF2NV1YPS	VFF2NV1YDS	
10"	1710	5430	175			VFF2NW1YXS	VFF2NW1YCS	VFF2NW1YES	VFF2NW1YPS	VFF2NW1YDS	
			50			VFF2PV1YXS	VFF2PV1YCS	VFF2PV1YES	VFF2PV1YPS	VFF2PV1YDS	
12"	2563	8077	175			VFF2PW1YXS	VFF2PW1YCS	VFF2PW1YES	VFF2PW1YPS	VFF2PW1YDS	
			50			VFF2RV1YXS	VFF2RV1YCS	VFF2RV1YES	VFF2RV1YPS	VFF2RV1YDS	
14"	3384	10538	150			VFF2RW1YXS	VFF2RW1YCS	VFF2RW1YES	VFF2RW1YPS	VFF2RW1YDS	
			50			VFF2SV1YXS	VFF2SV1YCS	VFF2SV1YES	VFF2SV1YPS	VFF2SV1YDS	
16"	4483	13966	150			VFF2SW1YXS	VFF2SW1YCS	VFF2SW1YES	VFF2SW1YPS	VFF2SW1YDS	
			50			VFF2TV1YXS	VFF2TV1YCS	VFF2TV1YES	VFF2TV1YPS	VFF2TV1YDS	
18"	5736	17214	150			VFF2TW1YXS	VFF2TW1YCS	VFF2TW1YES	VFF2TW1YPS	VFF2TW1YDS	
			50			VFF2UV1YXS	VFF2UV1YCS	VFF2UV1YES	VFF2UV1YPS	VFF2UV1YDS	
20"	7144	22339	150			VFF2UW1YXS	VFF2UW1YCS	VFF2UW1YES	VFF2UW1YPS	VFF2UW1YDS	

*Use full cut, 175psid close-off valves - No under-cut, 50psid close-off valve available

Section 3: Submittal Sheets

Rectangular Volume Control Dampers		Unitary Valve Actuator	
D1 Series	78	VU443; VU444; VU843; VU844	115
D2 and D3 Series	79	VC Series Two-position	116
Round Volume Control Dampers		VC Series Proportional	117
D690	80	VC Series Fail Safe Proportional	118
DM7600	81	M6410; M7410	119
Spring Return Direct Coupled Actuator		M6435; M7435	120
S03 Series (MS4103; MS4603; MS7403; MS7503; MS8103) ..	82	Direct Coupled Valve Actuator	
S05 Series (MS4105; MS4605; MS7105; MS7405; MS7505; MS8105)	83	ML6420; ML7420	121
S05 Series (MS4105; MS7505; MS8105)	84	ML6421; ML7421	122
S10 Series (MS4110; MS7510; MS8110)	85	ML6425; ML7425	123
S20 Series (MS4120; MS7520; MS8120)	86	ML6984	124
ML4125; ML8125	87	ML7984	125
Non-Spring Return Direct Coupled Actuator		Unitary Valve	
ML6161; ML7161	88	VU52; VU53	126
ML6174; ML7174	89	VU54	127
N05 Series (MN6105; MN7505)	90	VCZA; VCZB	128
N10 Series (MN6110; MN7510)	91	VCZM; VCZN	129
N20 Series (MN6120; MN7220)	92	V5852; V5862	130
N34 Series (MN6134; MN7234)	93	V5853; V5863	131
Fire And Smoke Actuators		Control Ball Valve	
ML4115; ML8115	94	VBN2	132
MS4209F; MS4309F; MS4709F; MS4809F; MS8209F; MS8309F	95	VBN3	133
MS4120F; MS4620F; MS8120F	96	VBF2	134
Pneumatic Damper Actuator		VBF3	135
MP909D	97	NPT Globe Valve	
MP909E, H	98	V5011F, G	136
MP913	99	V5011N	137
MP918A, B	100	V5013N	138
MP920	101	Flanged Cage Valve	
Pneumatic Valve Actuator		V5051A	139
MP953C, D	102	Flanged Globe Valve	
MP953E, F	103	V5011A, B	140
MP958	104	V5013B, C	141
Modutrol IV Motor		VGF2	142
M4185; M8185	105	VGF2 Pressure Balanced	143
M6184; M6194	106	VGF3	144
M6285 for slaving applications	107	Resilient Seat Butterfly Valves	
M6284; M6294 for slaving applications	108	VFF1	145
M6274; M6284; M6285; M6294 Motors with Linear 10K Feedback	109	VFF2	146
M7164	110	VFF3	147
M7274; M7284; M7285; M7286; M7294	111	VFF6	148
M9164; M9174; M9182; M9184; M9194	112	Damper Linkage	
M9175; M9185; M9186	113	Q605	149
Q7130; Q7230; Q7330	114	Valve Linkage	
		Q5001	150
		Q5020	151
		Q5022	152

Rectangular Volume Control Dampers

D1 Series



The D1 series is an extremely low leakage damper with rugged steel airfoil blades designed to meet the highest standards established. It is intended for application in medium to high pressure and velocity ratings.

Performance Data D1 Pressure and Velocity Limits.

Damper Size in in.	Maximum System Pressure	Maximum System Velocity
12 x 12	8.0 in. wg	4000 fpm
24 x 24	8.0 in. wg	4000 fpm
36 x 36	6.3 in. wg	3500 fpm
48 x 48	4.7 in. wg	3000 fpm
60 x 60	2.0 in. wg	2500 fpm

SPECIFICATIONS

Size Range¹
 Minimum Size
 One Blade 6 in. wide by 6 in. high
 Two Blade 6 in. wide by 10 in. high
 Maximum Size
 Single Section 60 in. wide by 74 in. high
 Multiple Section unlimited
 Temperature Rating 180 F (82 C) maximum²
 Standard Construction³
 Blade: 14 gauge galvanized steel, airfoil shaped
 Action: Parallel or Opposed
 Frame³: 16 gauge galvanized steel Hat-channel
 Bearings³ Synthetic (Acetal)
 Linkage³ Steel Side linkage out of airstream (concealed in frame)
 Axles³ 1/2 in. diameter plated steel
 Jamb Seals³ 304 Stainless Steel
 Blade Edge Seals³ Silicone

¹ Width and height dimensions furnished 1/4 in. undersized - standard

² Temperature rating can higher with a different

³ See table for customized options

DIMENSIONS DIAGRAM

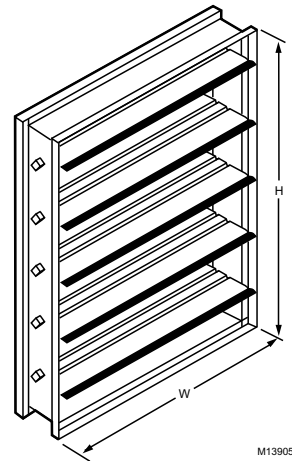

M13905

LEAKAGE RATE

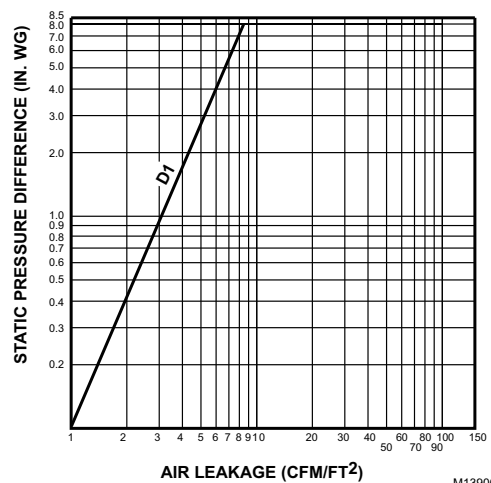

M13906

FLANGE OPTIONS

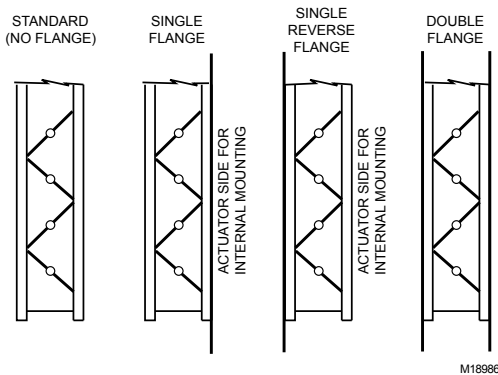

M18986

Rectangular Volume Control Dampers

D2 and D3 Series



D2 series is an ultra-low leakage control damper which includes blade and jamb seals. The D3 series is a general purpose damper intended for applications where low leakage performance is not necessary.



Honeywell International, Inc. certifies that the models D2, and D3 shown herein are licensed to bear the AMCA Seal. The ratings shown are based on tests and procedures performed in accordance with AMCA Publication 511 and comply with the requirements of the AMCA Certified Ratings Programs. The AMCA Certified Ratings Seal applies to air performance ratings only. March 2008.

Performance Data D2, D3 Pressure and Velocity Limits.

Damper Size in in.	Maximum System Pressure	Maximum System Velocity
12 x 12	5.0 in. wg	3000 fpm
24 x 24	5.0 in. wg	3000 fpm
36 x 36	4.0 in. wg	2500 fpm
48 x 48	2.5 in. wg	2000 fpm

SPECIFICATIONS

- Size Range¹
- Minimum Size
- One Blade 6 in. wide by 6 in. high
- Two Blade 6 in. wide by 10 in. high
- Maximum Size
- Single Section 48 in. wide by 72 in. high
- Multiple Section unlimited
- Temperature Rating 180 F (82 C) maximum
- Standard Construction²
- Blade: 16 gauge galvanized steel 3-V
- Action: Parallel or Opposed
- Frame²: 16 gauge galvanized steel Hat-channel
- Bearings² Synthetic (Acetal)
- Linkage Side linkage out of airstream (concealed in frame)
- Axles 1/2 in. square plated steel
- Jamb Seals³ Compression-type Stainless Steel
- Blade Edge Seals² Extruded Vinyl

¹ Width and height dimensions furnished 1/4 in. undersized - standard
² See table for customized options
³ D2 Dampers only

DIMENSIONS DIAGRAM

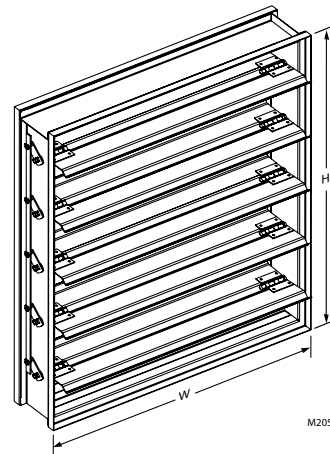

FLANGE OPTIONS

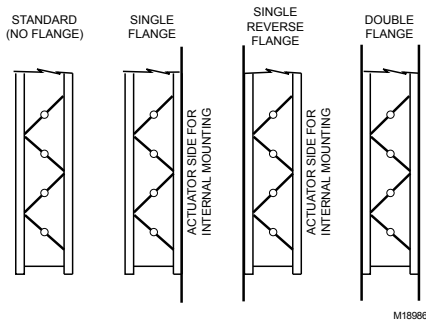

LEAKAGE RATE

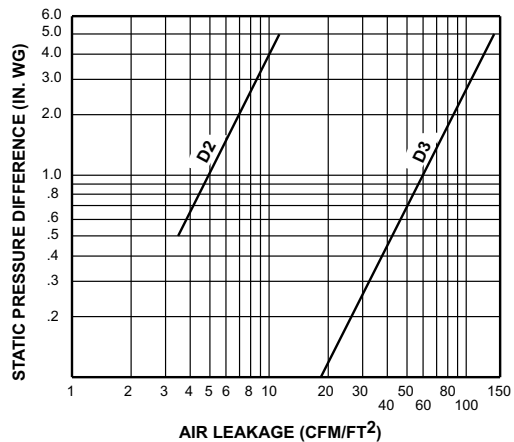

NOTE: D2 and D3 will withstand higher pressures and velocities. Displayed ratings are conservative to prevent misapplication. Consult Honeywell if you have an application outside these limitations.

Round Volume Control Dampers

D690



The D690 Round Damper is used in conventional air handling systems to control airflow in a round duct. The damper is designed for use with Honeywell ML6161 and ML7161 Direct Coupled Actuators.

FEATURES

- Neoprene seal for tight closing and low leakage
- Oilite™ bearings for long life
- 90 degree damper travel for a variety of applications

SPECIFICATIONS

Applicationheating, cooling, ventilating
 Type of BladeSingle-blade, round
 Temperature Range32 F to 130 F (0 C to 54 C)
 Integral ActuatorNone
 Input Signalnone
 Used WithML6161; ML7161; W7751 VAV
 Controller

DIMENSIONS DIAGRAM

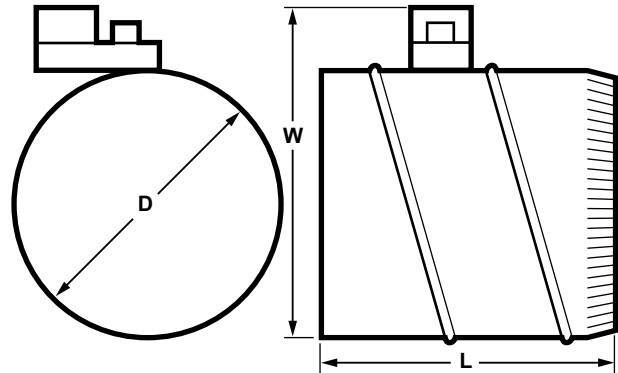

DAMPER DIAMETER (D)		WIDTH (W)		LENGTH (L)	
in.	mm	in.	mm	in.	mm
6	152	9-1/2	241	12	305
8	203	11-1/2	292	12	305
10	254	13-1/2	343	12	305
12	305	15-1/2	394	13	330
14	356	17-1/2	445	15	381
16	406	19-1/2	495	17	432

M17412

Round Volume Control Dampers

DM7600



The DM7600 Commercial Zone Damper is used in zoning systems to control airflow in a round duct. A Honeywell ML6161 or ML7161 Direct Coupled Actuator is factory mounted to the damper to simplify field installation.

FEATURES

- Neoprene seal for tight closing and low leakage
- Oilite bearings for long life
- 90 degree damper travel for a variety of applications
- Magnetic coupling requires no limit switches or mechanical stops

SPECIFICATIONS

Application	heating, cooling, ventilating
Type of Blade	Single-blade, round
Temperature Range	32 F to 130 F (0 C to 54 C)
Integral Actuator	2 to 10 Vdc or 4 to 20 mA, ML7161A2008
Input Signal	2 to 10 Vdc or 4 to 20 mA
Maximum Approach Velocity (ft/ min)	2500 ft/min
Voltage	24 Vac
Frequency	50 Hz; 60 Hz

DIMENSIONS DIAGRAM

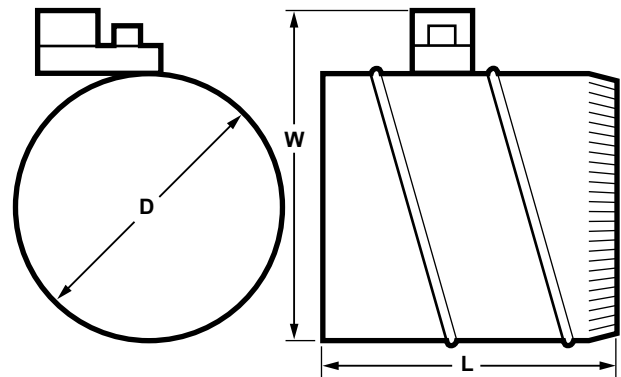

DAMPER DIAMETER (D)		WIDTH (W)		LENGTH (L)	
in.	mm	in.	mm	in.	mm
6	152	9-1/2	241	12	305
8	203	11-1/2	292	12	305
10	254	13-1/2	343	12	305
12	305	15-1/2	394	13	330
14	356	17-1/2	445	15	381
16	406	19-1/2	495	17	432

M17412

SUBMITTAL SHEETS

Spring Return Direct Coupled Actuator

S03 Series (MS4103; MS7403; MS7503; MS8103)



MS4103, MS7403, MS7503, MS8103 Spring Return Direct Coupled Actuators (DCA) are used within heating, ventilating, and air-conditioning (HVAC) systems. They can drive a variety of quarter-turn, final control elements requiring spring return fail-safe operation.

FEATURES

- Volume control dampers, mounted directly to the drive shaft or remotely (with the use of accessory hardware).
- Quarter-turn rotary valves, such as ball or butterfly valves mounted directly to the drive shaft.
- Linear stroke globe or cage valves mounted with linkages to provide linear actuation.

SPECIFICATIONS

Actuator Type	Damper, Valve
Rotational Stroke	95 ±3 degrees
Fail Safe Mode	Spring Return
Rated Torque	27 lb-in. (3 Nm)
External Auxiliary Switches Available ..	No
Electrical Connections	Enclosed screw terminal strip (22 to 14 AWG)
Environmental Rating	NEMA2
Frequency	50 Hz; 60 Hz
Mounting	Direct Coupled
Maximum Noise Rating, Holding (dBA @ 1m)	20 (no audible noise)
Maximum Noise Rating, Driving (dBA @ 1m)	50
Timing, Nominal Driving at 60 Hz	45 sec. or 90 sec.
Power Consumption, Driving	6.5 VA, 7 VA, or 10 VA
Rotation to Open	By switch
Rotational Stroke Adjustment	Mechanically limited 5 degree increments
Compatible Damper Shafts	3/8 to 5/8 round or 1/4 to 1/2 square (9 to 16 round or 6 to 13 square)
Shaft Adapter Type	Self-centering clamping
Materials	Plenum rated plastic housing
Ingress Protection Rating	IP54
Operating Humidity Range (% RH)	5 to 95% RH, non-condensing
Ambient Temperature Range	-40 F to 150 F (-40 C to 65 C) -22 F to 150 F (-30 C to 65 C) Two-position models only
Temperature Ratings (Shipping)	-40 F to 150F (-40 C to 65 C)
Storage Temperature Range	-40 F to 150F (-40 C to 65 C)
Weight	3.5 lb (1.6 kg)
Includes	Mounting bracket, self- centering shaft adapter

APPROVALS

CE	2006/95/EC (Low Voltage Directive) EMC 2004/108/EC
C-Tick	N314
International Electrotechnical Commission IEC 60730-1 and Part 2—14	
Underwriters Laboratories, Inc.	UL 873 UL1097 for Double Insulation

DIMENSIONS DIAGRAM

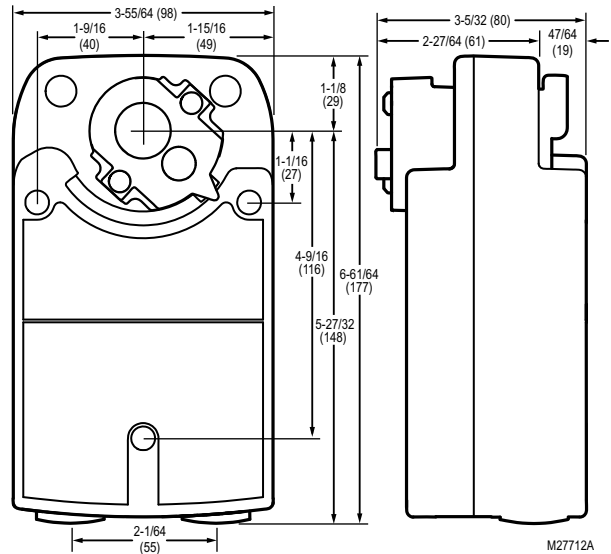

Spring Return Direct Coupled Actuator

S05 Series (MS4105; MS7105; MS7405; MS7505; MS8105)



MS4105, MS7405, MS7505, MS8105 Spring Return Direct Coupled Actuators (DCA) are used within heating, ventilating, and air-conditioning (HVAC) systems. They can drive a variety of quarter-turn, final control elements requiring spring return fail-safe operation.

FEATURES

- Volume control dampers, mounted directly to the drive shaft or remotely (with the use of accessory hardware).
- Quarter-turn rotary valves, such as ball or butterfly valves mounted directly to the drive shaft.
- Linear stroke globe or cage valves mounted with linkages to provide linear actuation.

SPECIFICATIONS

Actuator Type	Damper, Valve
Rotational Stroke	95 ±3 degrees
Fail Safe Mode	Spring Return
Rated Torque	44 lb-in. (5 Nm)
External Auxiliary Switches Available ..	No
Electrical Connections	Enclosed screw terminal strip (22 to 14 AWG)
Environmental Rating	NEMA2
Frequency	50 Hz, 60 Hz
Mounting	Direct Coupled
Maximum Noise Rating, Holding (dBA @ 1m)	20 (no audible noise)
Maximum Noise Rating, Driving (dBA @ 1m)	50
Timing, Nominal Driving at 60 Hz	45 sec. or 90 sec.
Power Consumption, Driving	7.5 VA, 8 VA, or 11 VA
Rotation to Open	By switch
Rotational Stroke Adjustment	Mechanically limited 5 degree increments
Compatible Damper Shafts	3/8 to 5/8 round or 1/4 to 1/2 square (9 to 16 round or 6 to 13 square)
Shaft Adapter Type	Self-centering clamping
Materials	Plenum rated plastic housing
Ingress Protection Rating	IP54
Operating Humidity Range (% RH)	5 to 95% RH, non-condensing
Ambient Temperature Range	-40 F to 149F (-40 C to 65 C) -22 F to 150 F (-30 C to 65 C)
	Two-position models only
Temperature Ratings (Shipping)	-40 F to 150F (-40 C to 65 C)
Storage Temperature Range	-40 F to 150F (-40 C to 65 C)
Weight	3.5 lb (1.6 kg)
Includes	Mounting bracket, self-centering shaft adapter

APPROVALS

CE	2006/95/EC (Low Voltage Directive) EMC 2004/108/EC
C-Tick	N314
International Electrotechnical Commission IEC 60730-1 and Part 2—14	
Underwriters Laboratories, Inc.	UL 873 UL1097 for Double Insulation

DIMENSIONS DIAGRAM

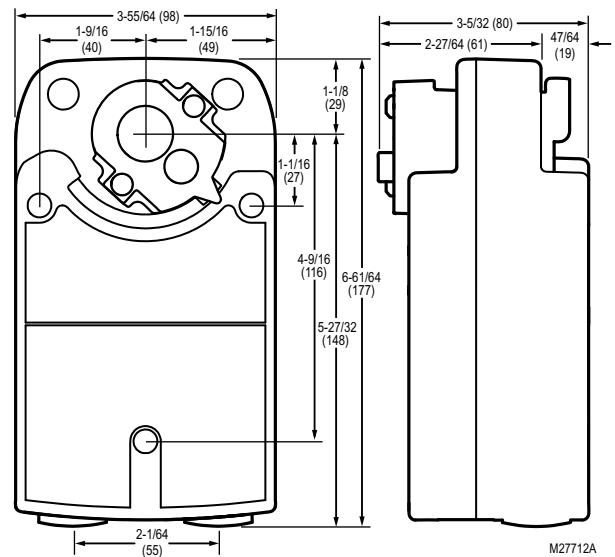

Spring Return Direct Coupled Actuator

S10 Series (MS4110; MS7510; MS8110)



MS4110, MS7510, MS8110 S10 Series Spring Return Direct Coupled Actuators (DCA) are used within heating, ventilating, and air-conditioning (HVAC) systems. They can drive a variety of quarter-turn, final control elements requiring spring return fail-safe operation.

SPECIFICATIONS

Actuator Type	Damper, Valve
Rotational Stroke	95 ±3 degrees
Fail Safe Mode	Spring Return
Rated Torque	88 lb-in. (10 Nm)
External Auxiliary Switches Available ..	Yes, SW2-US
Electrical Connections	Enclosed screw terminal strip (22 to 14 AWG)
Environmental Rating	NEMA2
Frequency	60 Hz
Manual operation	Manual crank
Mounting	Direct Coupled
Maximum Noise Rating, Holding (dBA @ 1m)	20 (no audible noise)
Maximum Noise Rating, Driving (dBA @ 1m)	40
Timing, Nominal Driving at 60 Hz	45 sec. or 90 sec.
Power Consumption, Driving	14 VA, 30 VA, or 45 VA
Rotational Stroke Adjustment	Mechanically limited 5 degree increments
Compatible Damper Shafts	3/8 to 1.06 round or 3/8 to 11/16 square (10 to 27 round or 10 to 18 square)
Shaft Adapter Type	Self-centering clamping
Supply Voltage	100 to 250 Vac
Materials	Aluminum housing, Plenum rated plastic access cover
Operating Humidity Range (% RH)	5 to 95% RH, non-condensing
Ambient Temperature Range	-40 F to 140 F (-40 C to 60 C)
Storage Temperature Range	-40 F to 158 F (-40 C to 70 C)
Weight	6 lb (2.72 kg)
Includes	Mounting bracket, self- centering shaft adapter, 3mm crank
Comments	Integral 1/2 in. NPSM conduit connection.

APPROVALS

CE	89/336/ECC, 73/23/EEC
C-Tick	N314
Underwriters Laboratories, Inc.	UL873, Plenum Rated
Canadian Underwriters Laboratories, Inc.	cUL C22.2 No. 24-93

FEATURES

- Brushless DC sub-motor with electronic stall protection for floating/modulating models.
- Brush DC sub-motor with electronic stall protection for 2-position models.
- Self-centering shaft adapter (shaft coupling) for wide range of shaft sizes.
- Models available for use with two-position, single pole single throw (SPST), line- (Series 40) or low- (Series 80) voltage controls.
- Models available for use with floating or switched single-pole, double-throw (SPDT) (Series 60) controls.
- Models available for use with proportional current or voltage (Series 70) controls.
- Models available with combined floating/modulating control in a single device.
- Models available with adjustable zero and span.
- Models available with line-voltage internal end switches.
- Access cover to facilitate connectivity.
- Metal housing with built-in mechanical end limits.
- Spring return direction field-selectable.
- Shaft position indicator and scale.
- Manual winding capability with locking function.
- UL (cUL) listed and CE compliant.
- All models are plenum-rated per UL873.

DIMENSIONS DIAGRAMS

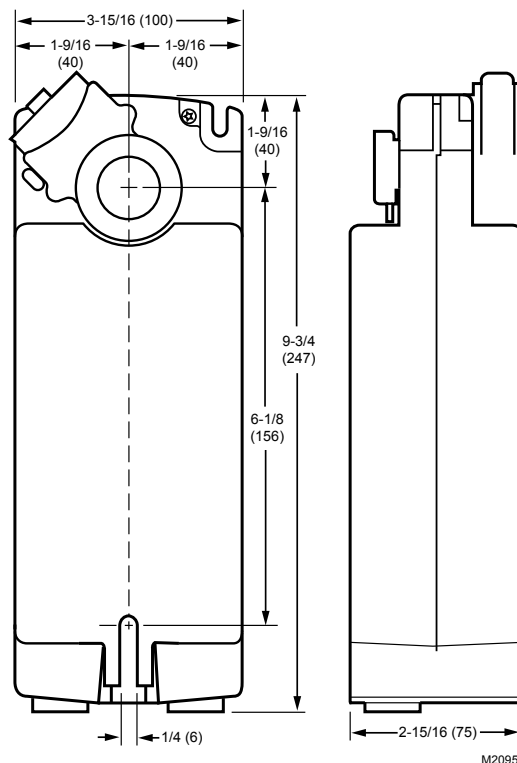

M20952

Spring Return Direct Coupled Actuator

S20 Series (MS4120; MS7520; MS8120)



MS4120, MS7520, MS8120 Spring Return Direct Coupled Actuators (DCA) are used within heating, ventilating, and air-conditioning (HVAC) systems. They can drive a variety of quarter-turn, final control elements requiring spring return fail-safe operation.

FEATURES

- Brushless DC sub-motor with electronic stall protection for floating/modulating models.
- Brush DC sub-motor with electronic stall protection for 2-position models.
- Self-centering shaft adapter (shaft coupling) for wide range of shaft sizes.
- Models available for use with two-position, single pole single throw (SPST), line- (Series 40) or low- (Series 80) voltage controls.
- Models available for use with floating or switched single-pole, double-throw (SPDT) (Series 60) controls.
- Models available for use with proportional current or voltage (Series 70) controls.
- Models available with combined floating/modulating control in a single device.
- Models available with adjustable zero and span.
- Models available with line-voltage internal end switches.
- Access cover to facilitate connectivity.
- Metal housing with built-in mechanical end limits.
- Spring return direction field-selectable.
- Shaft position indicator and scale.
- Manual winding capability with locking function.
- UL (cUL) listed and CE compliant.
- All models are plenum-rated per UL873.

SPECIFICATIONS

Actuator Type	Damper, Valve
Rotational Stroke	95 ±3 degrees
Fail Safe Mode	Spring Return
Rated Torque	175 lb-in. (20 Nm)
External Auxiliary Switches Available ..	Yes, SW2-US
Electrical Connections	Enclosed screw terminal strip (22 to 14 AWG)
Environmental Rating	NEMA2
Frequency	60 Hz
Manual operation	Manual crank
Mounting	Direct Coupled
Maximum Noise Rating, Holding (dBA @ 1m)	20 (no audible noise)
Maximum Noise Rating, Driving (dBA @ 1m)	40
Timing, Nominal Driving at 60 Hz	45 sec. or 90 sec.
Power Consumption, Driving	16 VA, 40 VA, or 60 VA
Rotational Stroke Adjustment	Mechanically limited 5 degree increments
Compatible Damper Shafts	3/8 to 1.06 round or 3/8 to 11/16 square (10 to 27 round or 10 to 18 square)
Shaft Adapter Type	Self-centering clamping
Supply Voltage	100 to 250 Vac
Materials	Aluminum housing, Plenum rated plastic access cover
Operating Humidity Range (% RH)	5 to 95% RH, non-condensing
Ambient Temperature Range	-40 F to 140 F (-40 C to 60 C)
Storage Temperature Range	-40 F to 158 F (-40 C to 70 C)
Weight	6 lb (2.72 kg)
Includes	Mounting bracket, self-centering shaft adapter, 3mm crank
Comments	Integral 1/2 in. NPSM conduit connection.

APPROVALS

CE	89/336/ECC, 73/23/EEC
C-Tick	N314
Underwriters Laboratories, Inc.	UL873, Plenum Rated
Canadian Underwriters Laboratories, Inc.	cUL C22.2 No. 24-93

DIMENSIONS DIAGRAMS

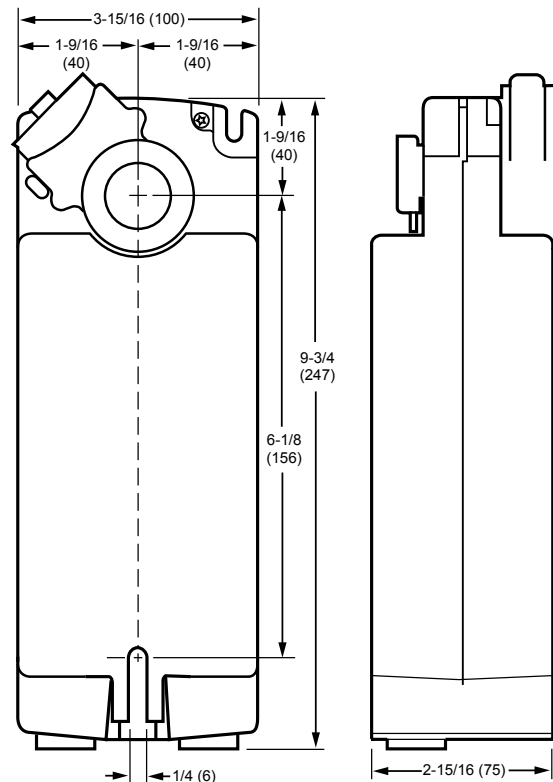

M20952

Spring Return Direct Coupled Actuator

ML4125; ML8125



The ML8125 Fast-Acting, Two-Position Actuators are spring return direct coupled actuators (DCA) with an integral junction box for on/off damper control.

FEATURES

- Integral spring return.
- -40 C to 130 F (-40 C to 54 C) operating temperature range.
- No audible noise during holding.
- Electronic circuitry provides efficient operation while eliminating the need for limit switches.
- Ninety-five degree angle of rotation.
- Die-cast aluminum housing. Housing design allows flush mounting to damper.
- Integral junction box with three conduit openings eliminates need for separate wiring box.
- Direct mounting to 3/8 or 1/2 in. round or square shaft.
- Not intended for smoke control systems.

SPECIFICATIONS

Actuator Type	Damper
Rotational Stroke	95 ±3 degrees
Fail Safe Mode	Spring Return
Rated Torque	100 lb-in. (11.3 Nm)
External Auxiliary Switches Available ..	Yes, 32003532-005
Electrical Connections	Two color-coded leads
Electrical Connection Length	16 in. (406 mm)
Environmental Rating	NEMA1
Frequency	60 Hz
Mounting	Direct Coupled
Maximum Noise Rating, Holding (dBA @ 1m)	20 (no audible noise)
Maximum Noise Rating, Driving (dBA @ 1m)	65
Timing, Nominal Driving at 60 Hz	20 sec
Power Consumption, Driving	0.18 A/18 W or 18 VA
Compatible Damper Shafts	3/8 to 1/2 in. square or round (10 to 13 square/round)
Shaft Adapter Type	Aluminum Hub, two set screws
Supply Voltage	120 Vac +10%, -15%
Materials	Aluminum housing
Operating Humidity Range (% RH)	5 to 95% RH, non-condensing
Ambient Temperature Range	-40 F to 130 F (-40 C to 55 C)
Storage Temperature Range	-40 F to 140 F (-40 C to 60 C)
Weight	6 lb (2.72 kg)
Includes	Ground Screw
Comments	Integral junction box with three 7/8 in. conduit openings (fittings not included)

APPROVALS

Underwriters Laboratories, Inc.	UL873, Plenum Rated
Canadian Underwriters Laboratories, Inc.	cUL C22.2 No. 24-93

DIMENSIONS DIAGRAMS

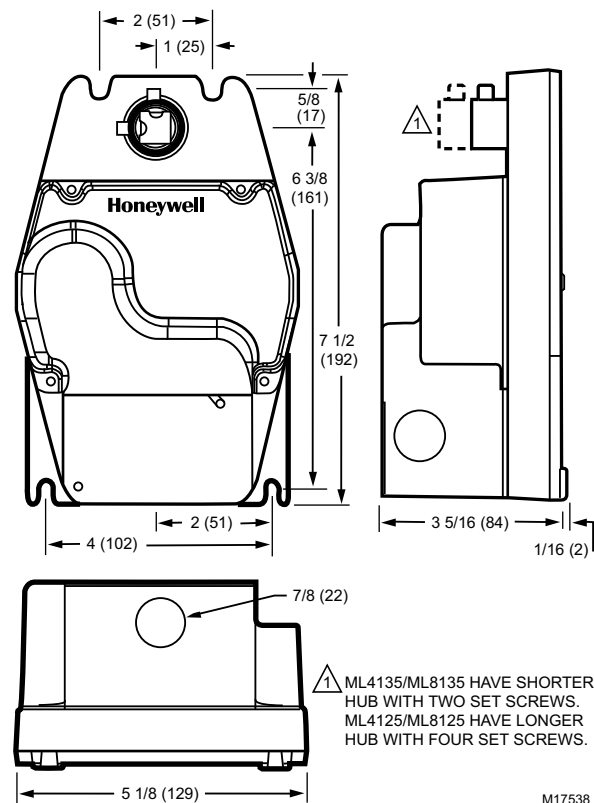

M17538

Spring Return Direct Coupled Actuator

ML4135; ML8135



The ML8135 Fast-Acting, Two-Position Actuators are spring return direct coupled actuators (DCA) with an integral junction box for on/off damper control.

FEATURES

- Integral spring return.
- -40 C to 130 F (-40 C to 54 C) operating temperature range.
- No audible noise during holding.
- Electronic circuitry provides efficient operation while eliminating the need for limit switches.
- Ninety-five degree angle of rotation.
- Die-cast aluminum housing. Housing design allows flush mounting to damper.
- Integral junction box with three conduit openings eliminates need for separate wiring box.
- Direct mounting to 3/8 or 1/2 in. round or square shaft.
- Not intended for smoke control systems.

SPECIFICATIONS

Actuator Type	Damper
Rotational Stroke	95 ±3 degrees
Fail Safe Mode	Spring Return
Rated Torque	40 lb-in. (4.5 Nm)
External Auxiliary Switches Available ..	Yes, 32003532-005
Electrical Connections	Two color-coded leads
Electrical Connection Length	16 in. (406 mm)
Environmental Rating	NEMA1
Frequency	60 Hz
Mounting	Direct Coupled
Maximum Noise Rating, Holding (dBA @ 1m)	20 (no audible noise)
Maximum Noise Rating, Driving (dBA @ 1m)	65
Timing, Nominal Driving at 60 Hz	25 sec
Power Consumption, Driving	0.12A/18.6W, 0.16A/15W or 15.6VA
Compatible Damper Shafts	3/8 to 1/2 in. square or round (10 to 13 square/round)
Shaft Adapter Type	Aluminum Hub, four set screws
Supply Voltage	120 Vac ±10%
Materials	Aluminum housing
Operating Humidity Range (% RH)	5 to 95% RH, non-condensing
Ambient Temperature Range	-40 F to 130 F (-18 C to 55 C)
Storage Temperature Range	-40 F to 140 F (-18 C to 60 C)
Weight	6 lb (2.72 kg)
Includes	Mounting bracket, ground screw
Comments	Integral junction box with three 7/8 in. conduit openings (fittings not included)

APPROVALS

Underwriters Laboratories, Inc.	UL873, Plenum Rated
Canadian Underwriters Laboratories, Inc.	cUL C22.2 No. 24-93

DIMENSIONS DIAGRAMS

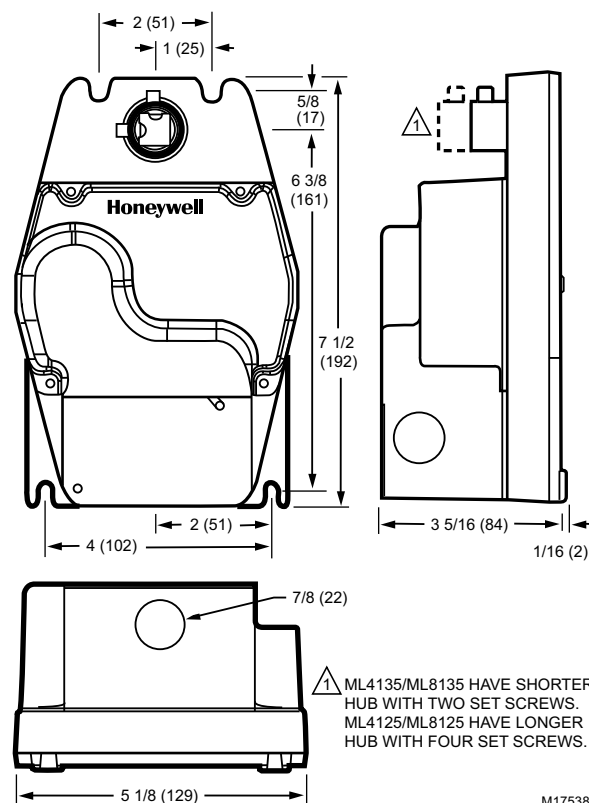

SUBMITTAL SHEETS

Non-Spring Return Direct Coupled Actuator

ML6161; ML7161



Used to control dampers in applications such as variable air volume (VAV) terminal units and for mounting on ball valves; suitable for use with SPDT or floating thermostats or building automation controls.

FEATURES

- Control for air damper applications with up to 10 sq.ft. assuming 3.5 lb-in. per sq.ft. of damper area, velocity independent.
- Superior A/C synchronous sub-motor for consistent timing and actuator longevity.
- Eliminate need for limit switches or mechanical stops by providing magnetic coupling.
- All models include manual declutch lever, and bag assembly with two minimum position setscrews.
- Mount directly on 3/8 in. or 1/2 in. square or round damper shaft.
- Selectable 45, 60, and 90 degree stroke in either clockwise or counterclockwise direction.

SPECIFICATIONS

Actuator Type	Damper
Rotational Stroke	90 degrees
Fail Safe Mode	Non-Spring Return
Rated Torque	35 lb-in. (4 Nm)
External Auxiliary Switches Available ..	Yes, 201052B
Electrical Connections	Screw terminals
Environmental Rating	NEMA1
Feedback	With accessory
Frequency	50 Hz, 60 Hz
Manual operation	Declutch mechanism
Mounting	Direct Coupled
Maximum Noise Rating,	
Driving (dBA @ 1m)	45
Timing, Nominal Driving at 60 Hz	90 sec., 180 sec. or 420 sec.
Power Consumption, Driving	1.8 VA or 5.4 VA
Rotation to Open	By wiring
Rotational Stroke Adjustment	Mechanically limited at 45 or 60 degrees in cw or ccw directions
Compatible Damper Shafts	3/8 to 1/2 in. square or round (10 to 13 square/round)
Shaft Adapter Type	Aluminum Hub, two set screws
Supply Voltage	24 Vac \pm 20%
Materials	Steel plate and Plenum rated plastic
Operating Humidity Range (% RH)	5 to 95% RH, non-condensing
Ambient Temperature Range	20 F to 125 F (-18 C to 50 C)
Storage Temperature Range	20 F to 130 F (-18 C to 54 C)
Weight	1.5 lb (0.68 kg)
Includes	4074ENY Bag Assembly

APPROVALS

CE	89/336/ECC, 73/23/EEC
C-Tick	N314
Underwriters Laboratories, Inc.	UL873, Plenum Rated
Canadian Underwriters Laboratories, Inc.	cUL C22.2 No. 24-93

DIMENSIONS DIAGRAMS

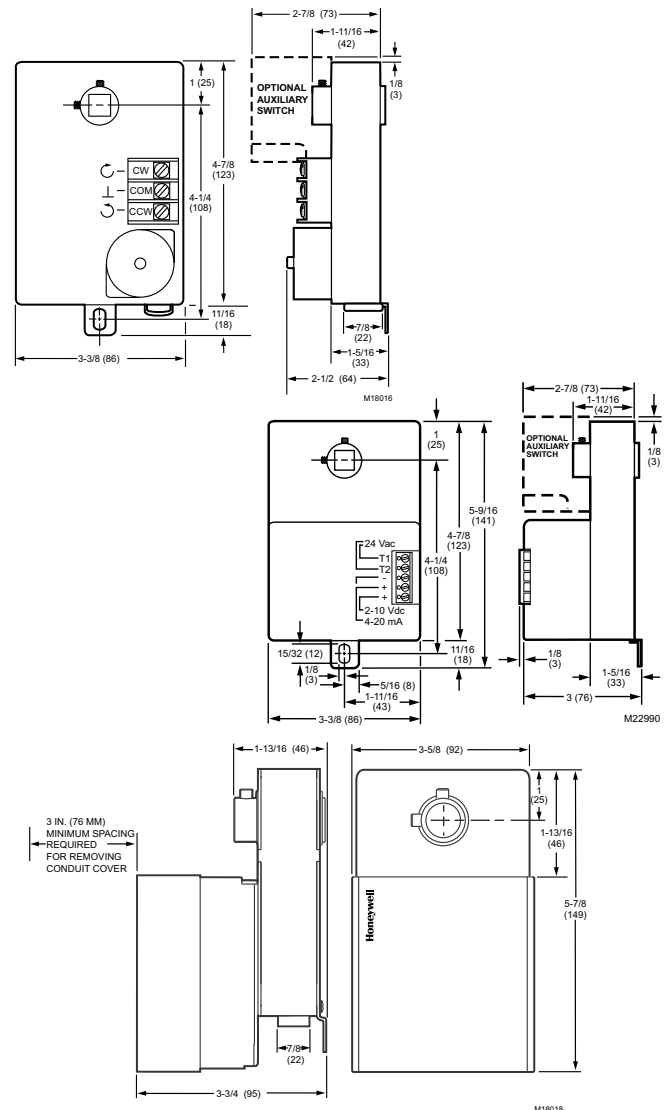

Non-Spring Return Direct Coupled Actuator

ML6174; ML7174



Used to control dampers in applications such as variable air volume (VAV) terminal units and for mounting on ball valves; suitable for use with SPDT or floating thermostats or building automation controls.

FEATURES

- Control for air damper applications with up to 20 sq.ft. assuming 3.5 lb-in. per sq.ft. of damper area, velocity independent.
- Magnetic coupling eliminates the need for mechanical stops or limit switch adjustments by limiting stall torque to 130 lb-in. maximum.
- Mount directly on 3/8 to 1/2 in. round and square damper shafts. All models include manual declutch lever for ease of mounting, and bag assembly with two minimum position setscrews. 90 second timing models are suitable for use with pressure independent VAV systems.
- Selectable 45, 60, and 90 degree stroke in either clockwise or counterclockwise direction.

SPECIFICATIONS

Actuator Type	Damper
Rotational Stroke	90 degrees
Fail Safe Mode	Non-Spring Return
Rated Torque	70 lb-in. (8 Nm)
External Auxiliary Switches Available ..	Yes, 201052B
Electrical Connections	Screw terminals
Environmental Rating	NEMA 1
Feedback	With accessory
Frequency	50 Hz, 60 Hz
Manual operation	Declutch mechanism
Mounting	Direct Coupled
Maximum Noise Rating,	
Driving (dBA @ 1m)	45
Timing, Nominal Driving at 60 Hz	90 sec., 180 sec. or 420 sec.
Power Consumption, Driving	2.4 VA or 5.4 VA
Rotation to Open	By wiring
Rotational Stroke Adjustment	Mechanically limited at 45 or 60 degrees in cw or ccw directions
Compatible Damper Shafts	3/8 to 1/2 in. square or round (10 to 13 square/round)
Shaft Adapter Type	Aluminum Hub, two set screws
Supply Voltage	24 Vac ±20%
Materials	Steel plate and Plenum rated plastic
Operating Humidity Range (% RH)	5 to 95% RH, non-condensing
Ambient Temperature Range	20 F to 125 F (-18 C to 50 C)
Storage Temperature Range	20 F to 130 F (-18 C to 54 C)
Weight	1.5 lb (0.68 kg)
Includes	4074ENY Bag Assembly

APPROVALS

Underwriters Laboratories, Inc.	UL873, Plenum Rated
Canadian Underwriters Laboratories, Inc.	cUL C22.2 No. 24-93

DIMENSIONS DIAGRAMS

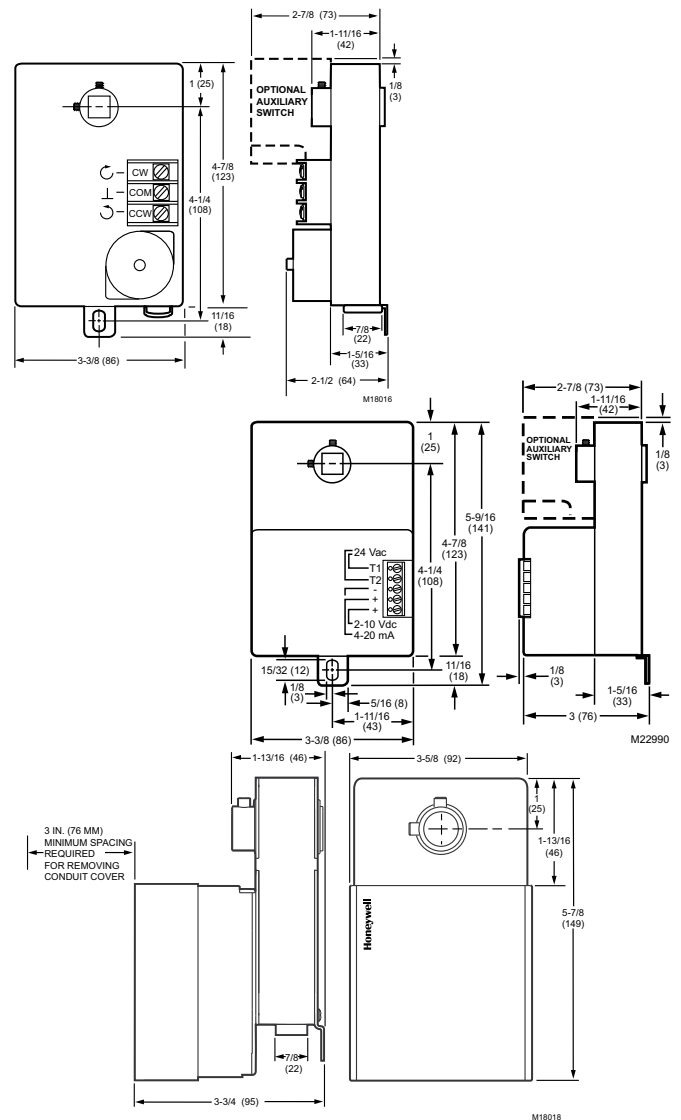

SUBMITTAL SHEETS

Non-Spring Return Direct Coupled Actuator

N05 Series (MN6105; MN7505)



This non-spring return direct-coupled damper actuator provides modulating and floating/2-position control for: air dampers, VAV units, air handlers, ventilation flaps, louvers, and reliable control for air damper applications with up to 10 sq. ft./ 44lb.-in. (5 Nm) and 20 sq. ft./88 lb.-in. (10 Nm) (seal-less damper blades; air friction-dependent).

FEATURES

- Declutch for manual adjustment
- Adjustable mechanical end limits
- Removable access cover for direct wiring
- Mountable in any orientation
- Function selection switch for selecting modulating or floating/2-position control

SPECIFICATIONS

Actuator Type	Damper, Valve
Rotational Stroke	95 ±3 degrees
Fail Safe Mode	Non-Spring Return
Rated Torque	44 lb-in. (5 Nm)
External Auxiliary Switches Available ..	Yes, SSW2
Electrical Connections	Enclosed screw terminal strip (22 to 14 AWG)
Environmental Rating	NEMA2
Frequency	50 Hz, 60 Hz
Manual operation	Declutch mechanism
Mounting	Direct Coupled
Maximum Noise Rating, Driving (dBA @ 1m)	35
Timing, Nominal Driving at 60 Hz	95 sec.
Power Consumption, Driving	5 VA
Rotation to Open	By switch
Rotational Stroke Adjustment	Dual Integral Adj. Stops (3 degree increments)
Compatible Damper Shafts	1/4 to 1/2 in. square; 3/8 to 5/8 in. round (6-13 mm square; 8-16 mm round)
Shaft Adapter Type	U-bolt clamp
Supply Voltage	24 Vac +20%, -15%, 24 Vdc
Materials	Plenum rated plastic housing
Ingress Protection Rating	IP54
Operating Humidity Range (% RH)	5 to 95% RH, non-condensing
Ambient Temperature Range	-5 F to 140 F (-20 C to 60 C)
Storage Temperature Range	-22 F to 176 F (-30 C to 80 C)
Weight	1 lb (0.45 kg)
Includes	Mounting bracket, screws, shaft adapter, water-tight strain-relief cable fittings
Comments	Integral 1/2 in. NPSM conduit connection.

APPROVALS

CE	89/336/ECC, 73/23/EEC
C-Tick	N314
Underwriters Laboratories, Inc.	UL873, Plenum Rated
Canadian Underwriters Laboratories, Inc.	cUL C22.2 No. 24-93

DIMENSIONS DIAGRAMS

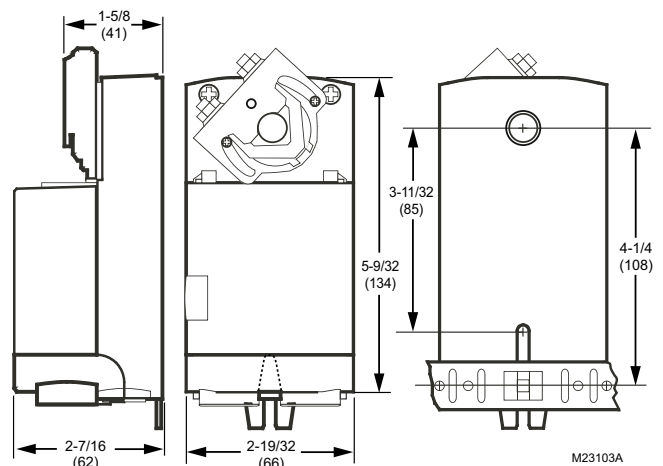

Non-Spring Return Direct Coupled Actuator

N10 Series (MN6110; MN7510)



This non-spring return direct-coupled damper actuator provides modulating and floating/2-position control for air dampers, VAV units, air handlers, ventilation flaps, louvers, and reliable control for air damper applications with up to 20 sq ft/88 lb-in. (10 Nm) (seal-less damper blades; air friction-dependent).

FEATURES

- Declutch for manual adjustment
- Adjustable mechanical end limits
- Removable access cover for direct wiring
- Mountable in any orientation
- Function selection switch for selecting modulating or floating/2-position control

SPECIFICATIONS

Actuator Type	Damper; Valve
Rotational Stroke	95 ±3 degrees
Fail Safe Mode	Non-Spring Return
Rated Torque	88 lb-in. (10 Nm)
External Auxiliary Switches Available ..	Yes, SSW2
Electrical Connections	Enclosed screw terminal strip (22 to 14 AWG)
Environmental Rating	NEMA2
Frequency	50 Hz, 60 Hz
Manual operation	Declutch mechanism
Mounting	Direct Coupled
Maximum Noise Rating, Driving (dBA @ 1m)	35
Timing, Nominal Driving at 60 Hz	95 sec.
Power Consumption, Driving	5 VA
Rotation to Open	By switch
Rotational Stroke Adjustment	Dual Integral Adj. Stops (3 degree increments)
Compatible Damper Shafts	1/4 to 1/2 in. square; 3/8 to 5/8 in. round (6-13 mm square; 8-16 mm round)
Shaft Adapter Type	U-bolt clamp
Supply Voltage	24 Vac +20%, -15%, 24 Vdc
Materials	Plenum rated plastic housing
Ingress Protection Rating	IP54
Operating Humidity Range (% RH)	5 to 95% RH, non-condensing
Ambient Temperature Range	-5 F to 140 F (-20 C to 60 C)
Storage Temperature Range	-22 F to 176 F (-30 C to 80 C)
Weight	1 lb (0.45 kg)
Includes	Mounting bracket, screws, shaft adapter, water-tight strain-relief cable fittings
Comments	Integral 1/2 in. NPSM conduit connection.

APPROVALS

CE	89/336/ECC, 73/23/EEC
C-Tick	N314
Underwriters Laboratories, Inc.	UL873, Plenum Rated
Canadian Underwriters Laboratories, Inc.	cUL C22.2 No. 24-93

DIMENSIONS DIAGRAMS

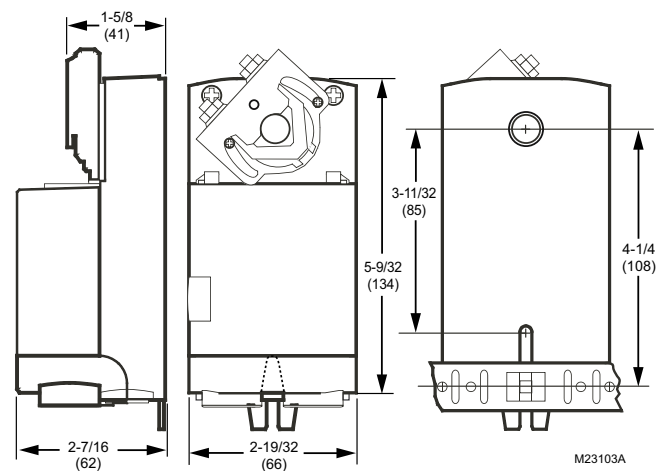

Non-Spring Return Direct Coupled Actuator

N20 Series (MN6120; MN7220)



These direct-coupled damper actuators provide adjustable modulating control for: air dampers, VAV units, air handling units, ventilation flaps, louvers, and reliable control for air damper applications with up to 4.6 m²/50 sq ft (seal-less dampers; air friction-dependent).

FEATURES

- Control for air damper applications with up to 50 sq ft assuming 3.5 lb-in. per sq ft of damper area, velocity independent.
- Patented self-centering shaft adapter.
- Access cover to facilitate connectivity.
- Declutch for manual adjustment.
- Mechanical end limits.
- Field-installable auxiliary switches.
- Rotation direction selectable by switch.
- Mountable in any orientation (no IP54 if upside down).
- Mechanical position indicator.
- CE approved. UL approved.

SPECIFICATIONS

Actuator Type	Damper; Valve
Rotational Stroke	95 ±3 degrees
Fail Safe Mode	Non-Spring Return
Rated Torque	175 lb-in. (20 Nm)
External Auxiliary Switches Available ..	Yes, SW2-US
Electrical Connections	Enclosed screw terminal strip (22 to 14 AWG)
Environmental Rating	NEMA2; IP54
Frequency	50 Hz, 60 Hz
Manual operation	Declutch mechanism
Mounting	Direct Coupled
Maximum Noise Rating,	
Driving (dBA @ 1m)	40
Timing, Nominal Driving at 60 Hz	95 sec.
Power Consumption, Driving	6 VA/6 W
Rotation to Open	By switch
Rotational Stroke Adjustment	Dual Integral Adj. Stops (3 degree increments)
Compatible Damper Shafts	3/8 to 1.06 round or 3/8 to 11/16 square (10 to 27 round or 10 to 18 square)
Shaft Adapter Type	Self-centering clamping
Supply Voltage	24 Vac ±15%
Materials	Plenum rated plastic housing
Operating Humidity Range (% RH)	5 to 95% RH, non-condensing
Ambient Temperature Range	-5 F to 140 F (-20 C to 60 C)
Storage Temperature Range	-40 F to 175 F (-40 C to 80 C)
Weight	3.2 lb (1.45 kg)
Includes	Mounting bracket, self- centering shaft adapter
Comments	Integral 1/2 in. NPSM conduit connection.

APPROVALS

CE	89/336/ECC, 73/23/EEC
C-Tick	N314
Underwriters Laboratories, Inc.	UL873, Plenum Rated
Canadian Underwriters	
Laboratories, Inc.	cUL C22.2 No. 24-93

DIMENSIONS DIAGRAMS

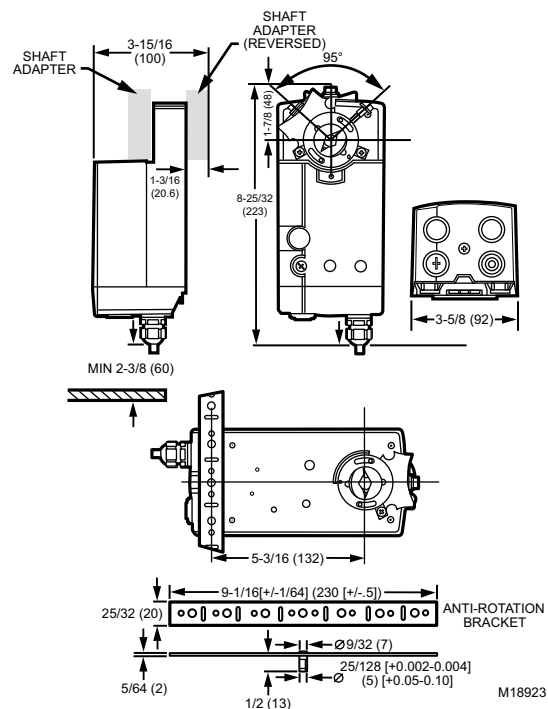

Non-Spring Return Direct Coupled Actuator

N34 Series (MN6134; MN7234)



These direct coupled damper actuators provide adjustable modulating control for air dampers, VAV units, air handling units, ventilation flaps, louvers, and reliable control for air damper applications with up to 7.9 m²/85 sq ft (seal-less dampers; air friction-dependent).

FEATURES

- Control for air damper applications with up to 85 sq ft assuming 3.5 lb-in. per sq ft of damper area, velocity independent.
- Patented self-centering shaft adapter.
- Access cover to facilitate connectivity.
- Declutch for manual adjustment.
- Mechanical end limits.
- Field-installable auxiliary switches.
- Rotation direction selectable by switch.
- Mountable in any orientation (no IP54 if upside down).
- Mechanical position indicator.
- CE approved. UL approved.

SPECIFICATIONS

Actuator Type	Damper; Valve
Rotational Stroke	95 ±3 degrees
Fail Safe Mode	Non-Spring Return
Rated Torque	300 lb-in. (34 Nm)
External Auxiliary Switches Available ..	Yes, SW2-US
Electrical Connections	Enclosed screw terminal strip (22 to 14 AWG)
Environmental Rating	NEMA2
Frequency	50 Hz; 60 Hz
Manual operation	Declutch mechanism
Mounting	Direct Coupled
Maximum Noise Rating, Driving (dBA @ 1m)	40
Timing, Nominal Driving at 60 Hz	95 sec.
Power Consumption, Driving	8 VA/6W or 9 VA/9W
Rotation to Open	By switch
Compatible Damper Shafts	3/8 to 1.06 round or 3/8 to 1 1/16 square (10 to 27 round or 10 to 18 square)
Shaft Adapter Type	Self-centering clamping
Supply Voltage	24 Vac ±15%, 24 Vdc
Materials	Plenum rated plastic housing
Operating Humidity Range (% RH)	5 to 95% RH, non-condensing
Ambient Temperature Range	-5 F to 140 F (-20 C to 60 C)
Storage Temperature Range	-40 F to 175 F (-40 C to 80 C)
Weight	3.2 lb (1.45 kg)
Includes	Mounting bracket, self-centering shaft adapter
Comments	Integral 1/2 in. NPSM conduit connection.

APPROVALS

CE	89/336/ECC, 73/23/EEC
C-Tick	N314
Underwriters Laboratories, Inc.	UL873, Plenum Rated
Canadian Underwriters Laboratories, Inc.	cUL C22.2 No. 24-93

DIMENSIONS DIAGRAMS

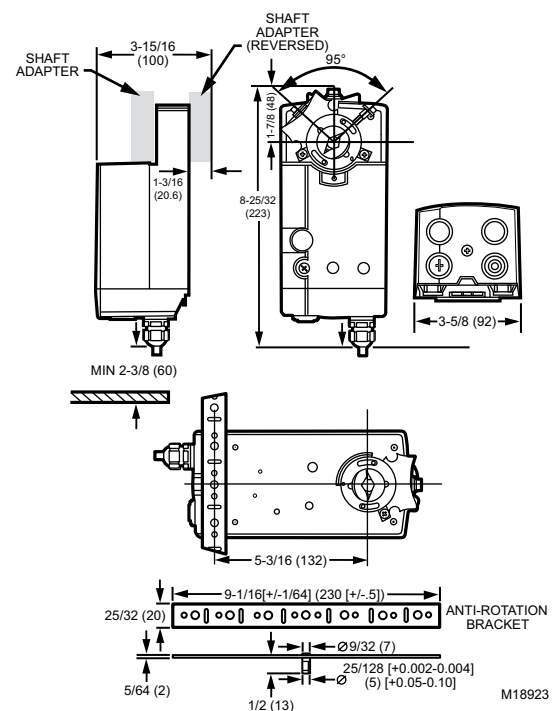

Fire And Smoke Actuator

ML4115; ML8115



Spring return direct coupled actuators (DCA) for on/off damper control with an integral junction box. The actuator accepts an on/off signal from a single-pole, single-throw (SPST) controller. They are designed to operate reliably in smoke control systems requiring Underwriter's Laboratories Inc. UL555S ratings up to 350 F.

FEATURES

- Integral spring return.
- No audible noise during holding.
- Electronic circuitry provides efficient operation while eliminating the need for limit switches.
- Ninety-five degree angle of rotation for tight damper closure.
- Die-cast aluminum housing.
- Housing design allows flush mounting to damper.
- Integral junction box with three conduit openings eliminates need for separate wiring box.
- Mounts to 3/8 or 1/2 in. round or square shaft.
- High-temperature indicator included.

SPECIFICATIONS

Actuator Type	Damper
Rotational Stroke	95 ±3 degrees
Fail Safe Mode	Spring Return
Rated Torque	30 lb-in. (3.4 Nm)
Maximum Stall Torque	150 lb-in. (17 Nm)
Minimum Driving Torque at 350 F	30 lb-in. (3.4 Nm)
Spring Return Torque	30 lb-in. (3.4 Nm)
External Auxiliary Switches Available ..	Yes, 32003532-005
Electrical Connections	Two color-coded leads
Electrical Connection Length	16 in. (406 mm)
Environmental Rating	NEMA1
Frequency	60 Hz
Mounting	Direct Coupled
Maximum Noise Rating, Holding (dBA @ 1m)	20 (no audible noise)
Maximum Noise Rating, Driving (dBA @ 1m)	65
Compatible Damper Shafts	3/8 to 1/2 in. square or round (10 to 13 square/round)
Shaft Adapter Type	Aluminum Hub, two set screws
Supply Voltage	120 Vac ±10%
Materials	Aluminum housing
Operating Humidity Range (% RH)	5 to 95% RH, non-condensing
Ambient Temperature Range	0 F to +30 F (-18 C to 55 C)
Storage Temperature Range	-40 F to 140 F (-40 C to 60 C)
Weight	6 lb (2.72 kg)
Includes	Ground Screw
Comments	Integral junction box with three 7/8 in. conduit openings (fittings not included)

APPROVALS

Underwriters Laboratories, Inc. UL873, Plenum Rated
Canadian Underwriters Laboratories, Inc. cUL C22.2 No. 24-93

DIMENSIONS DIAGRAMS

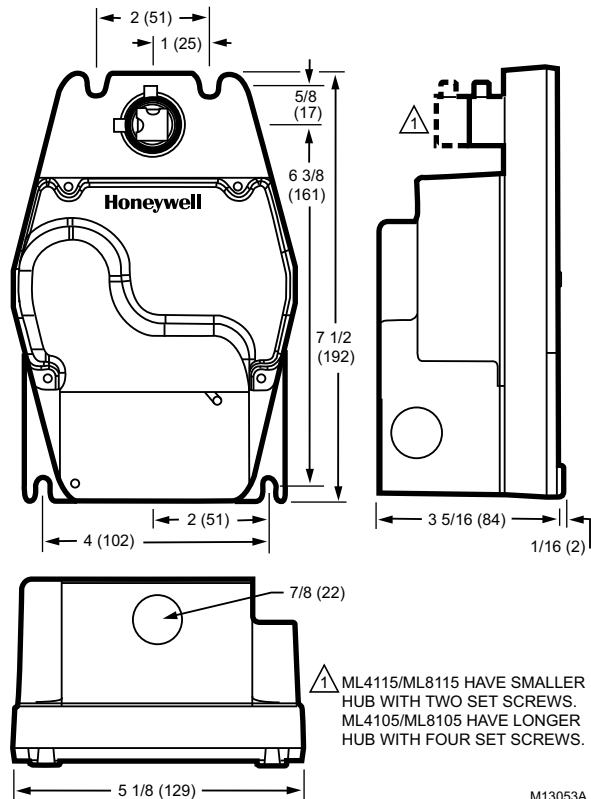

M13053A

Fire And Smoke Actuator

MS4209F; MS4309F; MS4709F; MS4809F; MS8209F; MS8309F



Spring return direct coupled actuators (DCA) for on/off damper control with an integral junction box. The actuator accepts an on/off signal from a single-pole, single-throw (SPST) controller. They are designed to operate reliably in smoke control systems requiring Underwriter's Laboratories Inc. UL555S ratings up to 350 F.

FEATURES

- Integral spring return ensures level of return torque.
- Fifteen-second spring return timing.
- No special cycling required during long-term holding.
- No audible noise during holding.
- Patent pending design eliminates need for limit switches to reduce power consumption.
- Models available for 24, 120, and 230 Vac.
- Ninety-five degree angle of rotation for tight damper closure.
- Actuator holds rated torque at reduced power level.
- Die-cast aluminum housing. Housing design allows flush mounting to damper.
- Integral junction box with three conduit openings eliminates need for separate wiring box.
- High-temperature indicator included.

SPECIFICATIONS

Actuator Type	Damper
Rotational Stroke	95 ±3 degrees
Fail Safe Mode	Spring Return
Rated Torque	80 lb-in. (9 Nm)
Maximum Stall Torque	240 lb-in. (27 Nm)
Minimum Driving Torque at 350 F	80 lb-in. (9 Nm)
Spring Return Torque	80 lb-in. (9 Nm)
External Auxiliary Switches Available ..	Yes, 32003532-005
Electrical Connections	Two color-coded leads
Electrical Connection Length	16 in. (406 mm)
Environmental Rating	NEMA1
Frequency	60 Hz
Mounting	Direct Coupled
Maximum Noise Rating, Holding (dBA @ 1m)	20 (no audible noise)
Maximum Noise Rating, Driving (dBA @ 1m)	80
Compatible Damper Shafts	3/8 to 1/2 in. square or round (10 to 13 square/round)
Shaft Adapter Type	Aluminum Hub, four set screws
Supply Voltage	120 Vac +10%, -15%
Materials	Aluminum housing
Operating Humidity Range (% RH)	5 to 95% RH, non-condensing
Ambient Temperature Range	0 F to 130 F (-18 C to 55 C)
Storage Temperature Range	-40 F to 140 F (-40 C to 60 C)
Weight	6 lb (2.72 kg)
Comments	Integral junction box with three 7/8 in. conduit openings (fittings not included)

APPROVALS

CE	89/336/ECC, 73/23/EEC
C-Tick	N314
Underwriters Laboratories, Inc.	UL873, Plenum Rated
Canadian Underwriters Laboratories, Inc.	cUL C22.2 No. 24-93

DIMENSIONS DIAGRAM

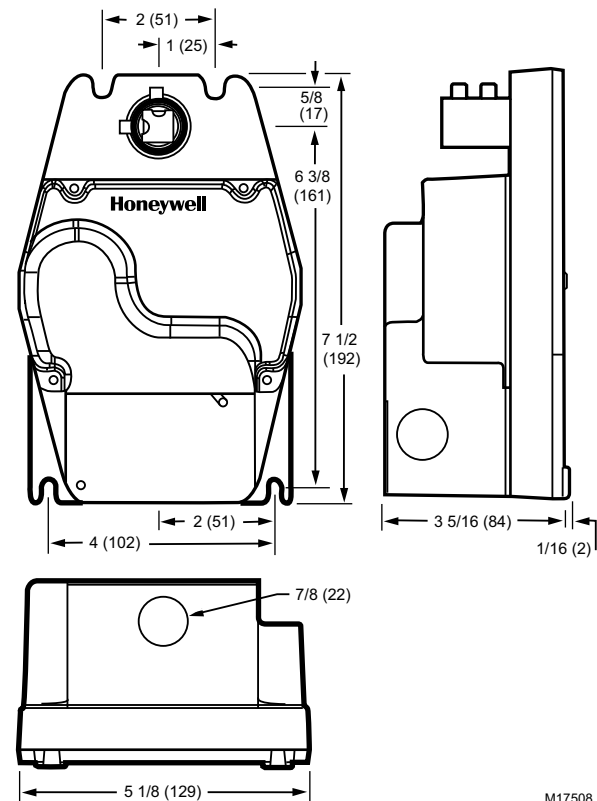

M17508

Fire And Smoke Actuator

MS4120F; MS4620F; MS8120F



Spring return direct coupled actuators (DCA) for on/off damper control with an integral junction box. The actuator accepts an on/off signal from a single-pole, single-throw (SPST) controller. They are designed to operate reliably in smoke control systems requiring Underwriter's Laboratories Inc. UL555S ratings up to 350 F.

FEATURES

- Brush DC sub-motor with electronic stall protection for 2-position models
- Self-centering shaft adapter (shaft coupling) for wide range of shaft sizes
- Models available for use with two-position, single pole single throw (SPST), line- (Series 40) or low- (Series 80) voltage controls
- Metal housing with built-in mechanical end limits
- Spring return direction field-selectable
- Shaft position indicator and scale
- Manual winding capability with locking function
- UL (cUL) listed and CE compliant
- All models are plenum-rated per UL873

SPECIFICATIONS

Actuator Type	Damper
Rotational Stroke	95 ±3 degrees
Fail Safe Mode	Spring Return
Rated Torque	175 lb-in. (20 Nm)
Maximum Stall Torque	425 lb-in. (48 Nm)
Minimum Driving Torque at 350 F	175 lb-in. (20 Nm)
Spring Return Torque	175 lb-in. (20 Nm)
External Auxiliary Switches Available ..	No
Electrical Connections	Teflon-jacketed cable
Electrical Connection Length	40 in. (1 m)
Environmental Rating	NEMA2
Frequency	60 Hz
Manual operation	Manual crank
Mounting	Direct Coupled
Maximum Noise Rating, Holding (dBA @ 1m)	20 (no audible noise)
Maximum Noise Rating, Driving (dBA @ 1m)	70
Compatible Damper Shafts	3/8 to 1.06 round or 3/8 to 11/16 square (10 to 27 round or 10 to 18 square)
Shaft Adapter Type	Self-centering clamping
Supply Voltage	120 Vac ±10%
Materials	Aluminum housing
Ingress Protection Rating	IP54
Operating Humidity Range (% RH)	5 to 95% RH, non-condensing
Ambient Temperature Range	-40 F to 130 F (-40 C to 55 C)
Storage Temperature Range	-40 F to 140 F (-40 C to 60) C
Weight	8 lb (3.63 kg)
Includes	Self-centering shaft adapter, 3mm crank
Comments	Two integral 3/8 in. flexible conduit connections

APPROVALS

CE	89/336/ECC, 73/23/EEC
C-Tick	N314
Underwriters Laboratories, Inc.	UL873, Plenum Rated
Canadian Underwriters Laboratories, Inc.	cUL C22.2 No. 24-93

DIMENSIONS DIAGRAM

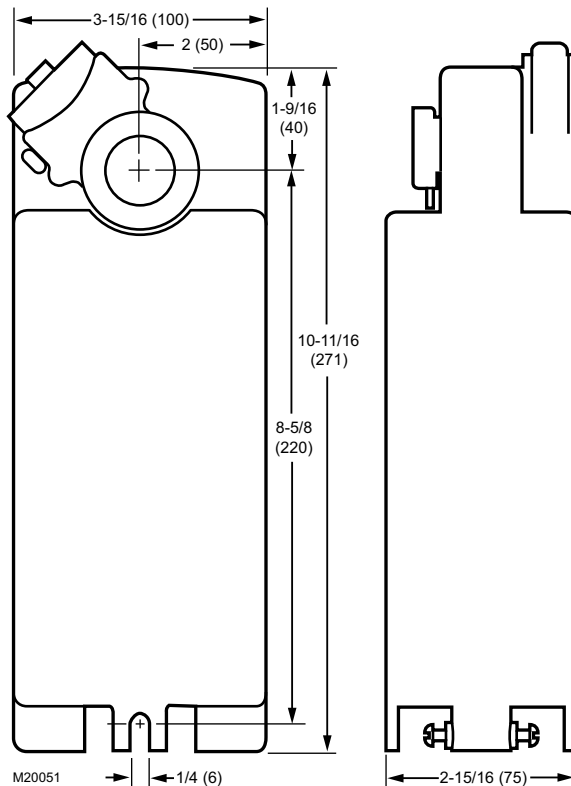



Used for pneumatic proportional control of variable volume terminal units and small dampers. Available in various operating ranges for either individual or sequence operation with other actuators. Replacement devices are available for Johnson, Powers, Robertshaw, and older Honeywell actuator models.

FEATURES

- Rugged ribbed aluminum body.
- Low-friction shaft bearing.
- Close tolerance on operating range and stroke.
- Protected barb connector.
- Versatile mounting and connecting hardware options.
- Positive leakproof seal.

SPECIFICATIONS

Actuator Type	Damper
Actuator Force	Low
Fail Safe Mode	Spring Return
Air Connections	Barbed fitting for 3/32 in. O.D. tubing
Stroke	2.4 in. (61 mm)
Diaphragm Effective Area	3 sq in. (19.4 sq cm)
Temperature Range	50 F to 140 F (10 C to 60 C)
Maximum Operating Pressure	30 psi (207 kPa)
Humidity Range	5 to 95% RH

APPROVALS

Underwriters Laboratories, Inc. Components Recognized:
Report R18118

ACCESSORIES

- 14002850-001—Angle Bracket 5 3/8 in, 137 mm, long, 5 in, 127 mm, wide
- 14003640-001—Angle Bracket 3 in. (76 mm) long, 3 3/4 in. (95 mm) wide, 2 3/4 in. (70 mm) high
- 26025B—Damper crank arm for 3/8 in. (9.5 mm) diameter axle.
Elongated slot for linkage connection. Slot scaled for 40-50-60-75-90 degrees.
- 27174B—Damper crank arm for 7/16 in. (11.1 mm) diameter axle.
Elongated slot for linkage connection. Slot scaled for 40-50-60-75-90 degrees.
- 27520C—Push Rod (5/16 in. dia., 12 in. length)
- 27520G—Push Rod (5/16 in. dia., 24 in. length)
- 27520K—Push Rod (5/16 in. dia., 36 in. length)
- 27520L—Push Rod (5/16 in. dia., 48 in. length)
- 312867C—Damper Crank Arm for 1/2 in. (12.7mm) diameter axle.
Elongated slot for linkage connection. Slot scaled for 45-60-75-90 degrees
- 315321—Crankarm Balljoint (with 1/4 in male threads), fits 5/16 in. diameter pushrod
- 315781—Motor shaft balljoint with 3/8 - 16 UNC female threads, fits 5/16 in. diameter pushrods.

DIMENSIONS DIAGRAMS

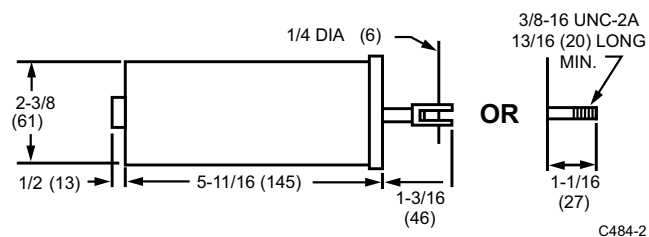

Pneumatic Damper Actuator

MP909E,H



These actuators are used for proportional control of variable volume terminal units, mixing boxes, and small to medium sized dampers. They are available in various operating ranges for either independent operation or sequence operation with other actuators. The MP909E has an optional adjustable stroke feature. The MP909H includes a positive positioner. Replacement devices are available for Johnson, Powers, Robertshaw, Barber-Colman, and older Honeywell actuator models.

SPECIFICATIONS

Actuator Type	Damper
Actuator Force	Medium
Fail Safe Mode	Spring Return
Air Connections	Dual Barbed fitting for 5/32 in. or 1/4 in. O.D. tubing
Stroke	4 in. (102 mm)
Diaphragm Effective Area	6.6 sq in. (43 sq cm)
Temperature Range	-28 F to 160 F (-33 C to 71 C)
Maximum Operating Pressure	29 psi (200 kPa)
Humidity Range	5 to 95% RH

APPROVALS

Underwriters Laboratories, Inc. Components Recognized:
Report R18118

ACCESSORIES

- 14002850-001—Angle Bracket 5 3/8 in, 137 mm, long, 5 in, 127 mm, wide
- 14003640-001—Angle Bracket 3 in. (76 mm) long, 3 3/4 in. (95 mm) wide, 2 3/4 in. (70 mm) high
- 14004062-001—External Trunnion Mounting Bracket
- 14004062-002—Internal N.C. Trunnion Mounting Bracket
- 14004062-003—Internal N.O. Trunnion Mounting Bracket
- 14004106-001—Actuator pushrod for conversion of internal N.C. to external
- 14004107-001—Crankarm Assembly for conversion from internal N.C. to external Trunnion mounting
- 14004210-001—Feedback Spring Kit includes orange spring (3 psi [21kPa]), yellow spring (5 psi [34 kPa]), and blue spring (10 psi [69 kPa]).
- 14004236-001—Coupler, actuator shaft to 5/16 in, 8 mm, pushrod
- 14004241-002—Hitch Pin (Six Sets)
- 14004242-001—MP918 Top Mount Operator Assembly
- 14004667-001—Offset Crank arm assembly with 2 screws (304725-062), nuts (14004102-001), crank arm (14004655-001) for 1/2 in. Drive Axle
- 26025B—Damper crank arm for 3/8 in. (9.5 mm) diameter axle. Elongated slot for linkage connection. Slot scaled for 40-50-60-75-90 degrees.
- 27518—Crankarm balljoint with 1/4 - 28 UNF male threads, fits 5-16 in. diameter push rods
- 312867C—Damper Crank Arm for 1/2 in. (12.7mm) diameter axle. Elongated slot for linkage connection. Slot scaled for 45-60-75-90 degrees
- 312867H—Externally mounted Linkage Kit
- 314440A—MP909 - Clevis, Clevis Pin and Cotter Pin Assembly
- 315321—Crankarm Balljoint (with 1/4 in male threads), fits 5/16 in. diameter pushrod
- 315781—Motor shaft balljoint with 3/8 - 16 UNC female threads, fits 5/16 in. diameter pushrods.

REPLACEMENT PARTS

- 14004137-001—Retrofit Kit for adding positive positioner to MP909E or repair of MP909H

FEATURES

- Rolling diaphragm operated.
- Low friction shaft bearing.
- Close tolerance on operating range and stroke.
- Non-overlapping spring ranges for sequencing.
- Corrosion resistant materials.
- Reliable long life.

DIMENSIONS DIAGRAM

Actuator with Fixed External Mounting Bracket

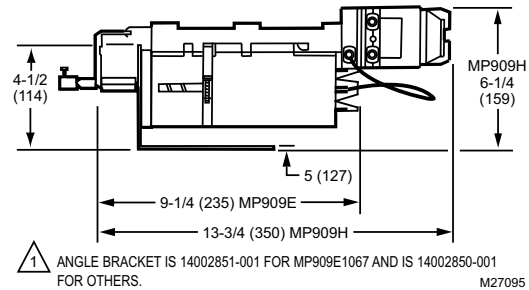

Actuator with Internal N.C. Trunnion Mounting Bracket

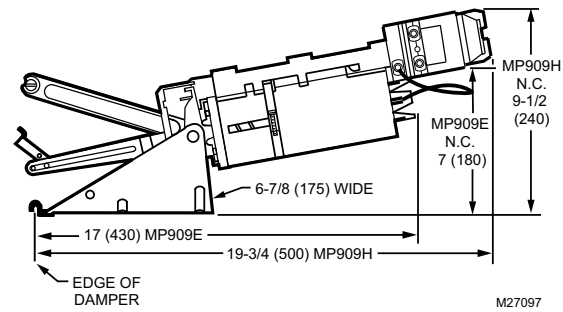

Actuator with External Trunnion Mounting Bracket

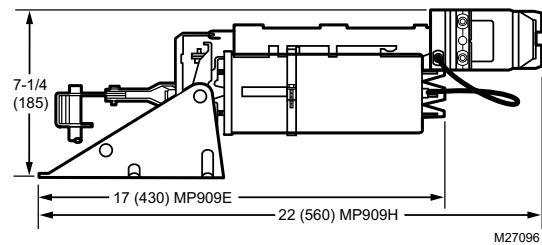

Actuator with Internal N.O. Trunnion Mounting Bracket

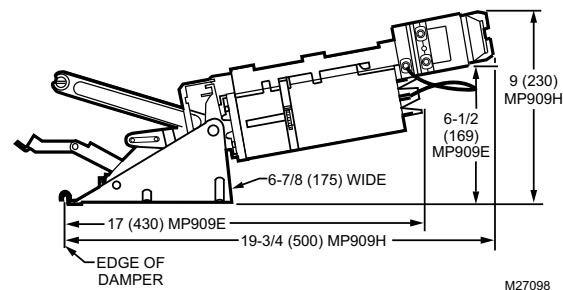



Provides proportional control of variable volume dampers in small high velocity mixing boxes. Replacement devices are available for Johnson and Robertshaw devices. Suitable for direct replacement only, do not attempt to replace larger damper actuators with this unit.

FEATURES

- Compact in size.
- Neoprene rolling diaphragm.
- The MP913 Operator can be used with or without a crankarm.

SPECIFICATIONS

Actuator Type	Damper
Dimensions, Approximate	2 5/8 in. high (add 3/4 in. for shaft) x 2 1/4 in. diameter (67 mm high (add 19 mm for shaft) x 57 mm diameter)
Actuator Force	Low
Fail Safe Mode	Spring Return
Air Connections	Barbed fitting for 1/4 in. O.D. plastic tubing
Stroke	1 in. (25 mm)
Diaphragm Effective Area	2.2 sq in. (14 sq cm)
Temperature Range	50 F to 140 F (10 C to 60 C)
Maximum Operating Pressure	30 psi (207 kPa)
Humidity Range	5 to 95% RH

ACCESSORIES

- 27520C—Push Rod (5/16 in. dia., 12 in. length)
- 27520G—Push Rod (5/16 in. dia., 24 in. length)
- 27520K—Push Rod (5/16 in. dia., 36 in. length)
- 27520L—Push Rod (5/16 in. dia., 48 in. length)
- 315321—Crankarm Balljoint (with 1/4 in male threads), fits 5/16 in. diameter pushrod
- 315781—Motor shaft balljoint with 3/8 - 16 UNC female threads, fits 5/16 in. diameter pushrods.

Pneumatic Damper Actuator

MP918A,B



Used for proportional control of medium- to large-size dampers in HVAC systems. The MP918A,B are rolling diaphragm, piston-type actuators. The MP918A has a positive positioner. Replacement devices are available for Johnson, Powers, Robertshaw, Barber-Colman, and older Honeywell actuator models.

FEATURES

- Rolling diaphragm operated.
- Low friction shaft bearing.
- Close tolerance on operating range and stroke.
- Versatile mounting and connecting hardware.
- Non-overlapping spring ranges for sequencing.
- Reliable-long life.

SPECIFICATIONS

Actuator Type	Damper
Actuator Force	High
Fail Safe Mode	Spring Return
Air Connections	5/32 in. push-on barb (Pilot), 1/4 in. push-on barb (main.)
Stroke	3 1/2 in. (90 mm)
Diaphragm Effective Area	23.8 sq in. (154 sq cm)
Temperature Range	-20 F to 158 F (-29 C to 70 C)
Maximum Operating Pressure	25 psi (172 kPa)
Humidity Range	5 to 95% RH

APPROVALS

Underwriters Laboratories, Inc. Components Recognized:
Report R18118

ACCESSORIES

- 14004062-001—External Trunnion Mounting Bracket
- 14004062-002—Internal N.C. Trunnion Mounting Bracket
- 14004062-003—Internal N.O. Trunnion Mounting Bracket
- 14004106-001—Actuator pushrod for conversion of internal N.C. to external
- 14004107-001—Crankarm Assembly for conversion from internal N.C. to external Trunnion mounting
- 14004210-001—Feedback Spring Kit includes orange spring (3 psi [21kPa]), yellow spring (5 psi [34 kPa]), and blue spring (10 psi [69 kPa]).
- 14004241-002—Hitch Pin (Six Sets)
- 14004242-001—MP918 Top Mount Operator Assembly
- 14004667-001—Offset Crank arm assembly with 2 screws (304725-062), nuts (14004102-001), crank arm (14004655-001) for 1/2 in. Drive Axle
- 14004236-001—Coupler, actuator shaft to 5/16 in, 8 mm, pushrod
- CCT2718—Threaded rod for shaft extension
- CCT2725—Rod coupling for shaft extension

REPLACEMENT PARTS

- 14004264-001—MP918 Repair kit including Positive Positioner, bracket assembly and fittings
- 14004264-002—MP918 Positive Positioner Retrofit Kit - includes 10 psi feedback spring

DIMENSIONS DIAGRAMS

Actuator with External Trunnion Mounting Bracket

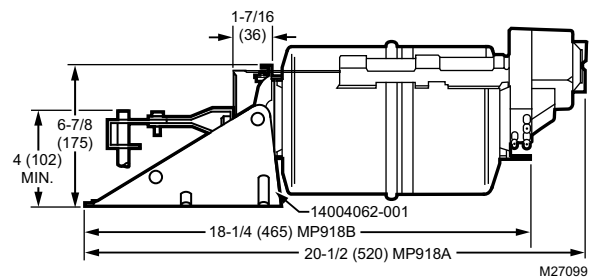

Actuator with Internal N.C. Trunnion Mounting Bracket

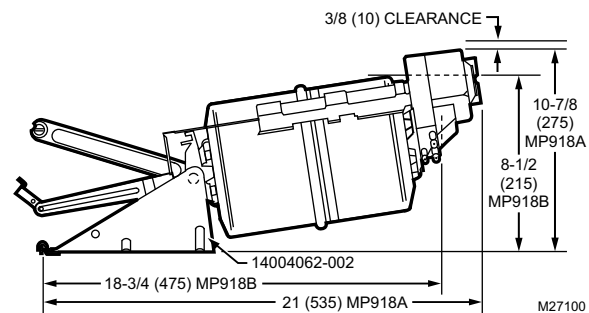

Actuator with Internal N.O. Trunnion Mounting Bracket

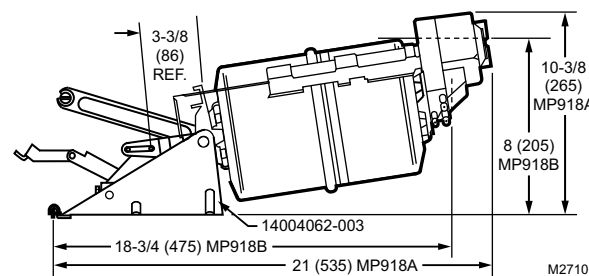



Provides proportional control of large dampers in HVAC systems or inlet vanes on a VAV fan. Positive positioner available separately. Replacement devices are available for Robertshaw actuator models.

FEATURES

- Rolling diaphragm operated.
- Fail safe on over pressure.
- Actuator can be swivel mounted from either end to pipe, floor, or wall surface.
- Optional positive positioner provides accurate positioning under varying load conditions.

SPECIFICATIONS

Actuator Type	Damper
Actuator Force	High
Fail Safe Mode	Spring Return
Air Connections	Barbed fitting for 1/4 in. O.D. plastic tubing
Stroke	6 in. (150 mm)
Diaphragm Effective Area	24.8 sq in. (160 sq cm)
Temperature Range	-20 F to 158 F (-30 C to 70 C)
Maximum Operating Pressure	29 psi (200 kPa)
Humidity Range	5 to 95% RH

ACCESSORIES

14004062-001—External Trunnion Mounting Bracket
14004241-002—Hitch Pin (Six Sets)
14004345-001—Positive Positioner Kit, 10 psi feedback spring
AK3556—Pipe Mounting Assembly for 1-1/4 in. pipe
AK3557—Short Clevis Bag Assembly for 3/8-16 threaded rod
AK3558—Swivel Bracket Bag Assembly
AK3559—Long Clevis Bag Assembly with actuator shaft coupling for 5/8-11 threaded rod
AK3560—Balljoint, 3/8-24 threaded stud with couplings for 5/8-11 threaded rod and actuator shaft
AK3561—Balljoint, 3/8-24 threaded stud with couplings for 3/8-16 threaded rod

DIMENSIONS DIAGRAMS

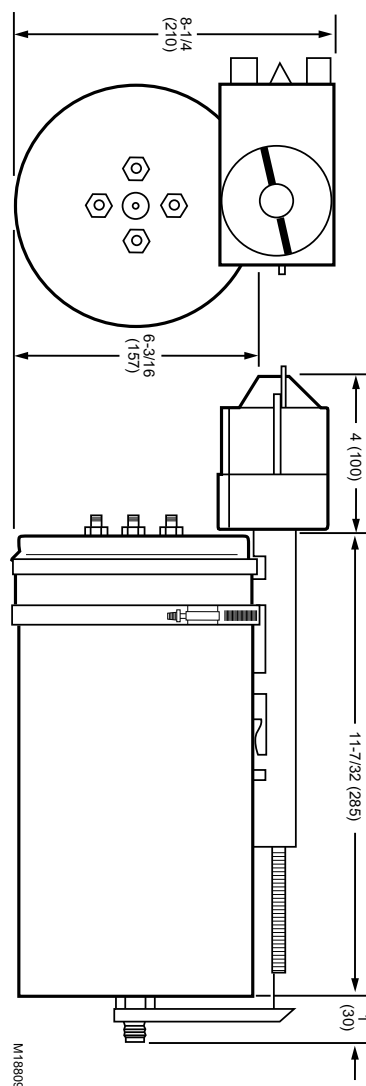

Pneumatic Valve Actuator

MP953C,D



Pneumatic actuators provide proportional control of steam or hot or cold liquids in HVAC systems by operating V5011, V5013, and VGF valve assemblies. Replacement devices are available for older Honeywell actuators.

FEATURES

- Rolling diaphragm for long life and low hysteresis.
- Easily attached to valve.
- Can be installed after piping valve.
- Slide lock feature permits simple engagement to valve stem.
- Direct- or reverse-action control.
- Does not include positive positioner.

SPECIFICATIONS

Actuator Type	Valve
Action	Direct Acting
Actuator Force	Medium
Fail Safe Mode	Spring Return
Air Connections	Main: Barbed fitting for 1/4 in. O.D. plastic tubing Pilot: Barbed fitting for 5/32 in. O.D. plastic tubing
Stroke	1 1/2 in. (38 mm)
Temperature Range	0 F to 140 F (-18 C to 60 C)
Maximum Operating Pressure	25 psi (172 kPa)
Humidity Range	5 to 95% RH

DIMENSIONS DIAGRAMS

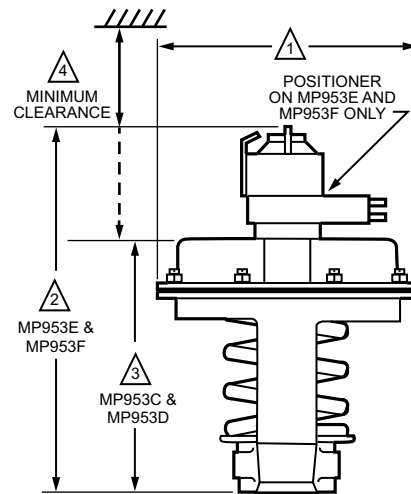

OPERATION SIZE NOMINAL DIA.	1	2	3	4
5 INCH	5-1/8 (130)	9-1/4 (235)	4-5/8 (117)	4-3/8 (111)
7-1/8 INCH	7-1/8 (181)	10-1/2 (267)	5-5/8 (143)	4-3/8 (111)
8 INCH	8-1/4 (210)	11-1/8 (283)	6-1/2 (165)	5-3/8 (137)
13 INCH	13-1/2 (343)	18-1/8 (460)	10 (254)	7-11/16 (195)

M13903

Pneumatic Valve Actuator

MP953E,F



Pneumatic actuators provide proportional control of steam or hot or cold liquids in HVAC systems by operating V5011, V5013, and VGF valve assemblies. Replacement devices are available for older Honeywell actuators.

FEATURES

- Rolling diaphragm for long life and low hysteresis.
- Easily attached to valve.
- Can be installed after piping valve.
- Slide lock feature permits simple engagement to valve stem.
- Direct- or reverse-action control.
- Integral positive positioner relay provides positive positioning under varying load conditions.

SPECIFICATIONS

Actuator Type	Valve
Action	Direct Acting
Actuator Force	Low
Fail Safe Mode	Spring Return
Air Connections	Dual barbed fitting for 5/32 in. O.D. and 1/4 in. O.D. plastic tubing
Stroke	3/4 in. (19 mm)
Temperature Range	0 F to 140 F (-18 C to 60 C)
Maximum Operating Pressure	25 psi (172 kPa)
Humidity Range	5 to 95% RH

DIMENSIONS DIAGRAMS

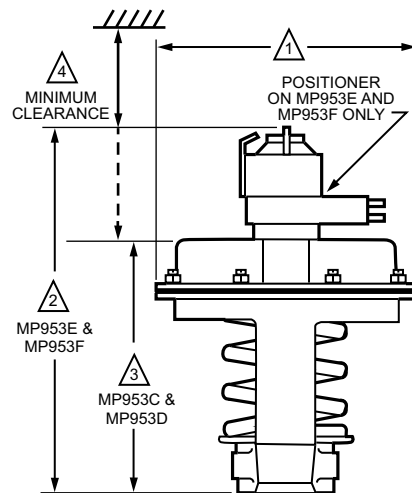

OPERATION SIZE NOMINAL DIA.	△1	△2	△3	△4
5 INCH	5-1/8 (130)	9-1/4 (235)	4-5/8 (117)	4-3/8 (111)
7-1/8 INCH	7-1/8 (181)	10-1/2 (267)	5-5/8 (143)	4-3/8 (111)
8 INCH	8-1/4 (210)	11-1/8 (283)	6-1/2 (165)	5-3/8 (137)
13 INCH	13-1/2 (343)	18-1/8 (460)	10 (254)	7-11/16 (195)

M13903

Pneumatic Valve Actuator

MP958



The MP958 Pneumatic Valve Actuator is direct-acting and used only with Honeywell V5852A2xx, V5862A2xx, V5853A2xx, and V5863A2xx Terminal Unit Valves to control hot and/or chilled water.

SPECIFICATIONS

Actuator Type	Valve
Action	Direct Acting
Actuator Force	Low
Fail Safe Mode	Spring Return
Air Connections	Barbed fitting for 1/4 in. O.D. plastic tubing
Maximum Operating Pressure	30 psi

DIMENSIONS DIAGRAM

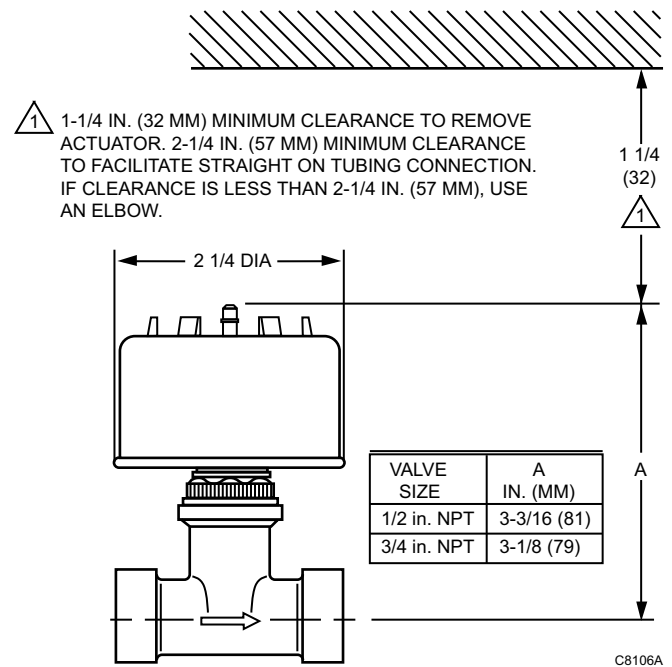



Series 41 and Series 81 Modutrol IV motors are 2-position (line- and low-voltage per motor control) spring-return motors. They are used to operate dampers or valves in applications where it is necessary or desirable to have the controlled element return to the starting position in the event of power failure or interruption.

SPECIFICATIONS

Application Type	Damper; Valve
Fail Safe Mode	Spring Return
Control Signal	Two position, SPST
Torque/Force	60 lb-in. (6.8 Nm)
External Auxiliary Switches Available ..	Yes
Auxiliary Switch Ratings	
AFL - 120 Vac	7.2A
Auxiliary Switch Ratings	
ALR - 120 Vac	43.2A
Auxiliary Switch Ratings	
AFL - 240 Vac	3.6A
Auxiliary Switch Ratings	
ALR - 240 Vac	21.6A
Feedback	No
Electrical Connections	Quick-connect terminals
Frequency	50 Hz, 60 Hz
Mounting	Foot-mounted
Motor Shafts	Dual-ended shaft
Shaft Shape	Square
Shaft Dimensions	0.375 in. (10 mm)
Deadweight Load on Shaft	
(Either End)	200 lb.
Deadweight Load	
(Combined on both Shafts)	300 lb
Ambient Temperature Range	-40 F to 150 F (-40 C to 60 C)
Weight	9.5 lb

APPROVALS

Canadian Standards Association	Certified: File No. LR1620, Guide No. 400-E
CE	EN55011 (Emission) EN50082-2 (Immunity) 73/23/EEC (LVD)
Underwriters Laboratories, Inc.	Listed File: E4436, Guide: XAPX2

ACCESSORIES

- Q7230A1005—Interface module, provides adjustable zero & span, voltage or current control
- 220736A—Internal Auxiliary Switch Assembly - 1 Switch
- 220736B—Internal Auxiliary Switch Assembly - 2 Switches
- 50017460-001—24/120/230 Vac Internal Transformers for Series 2 Motors
- 50017460-003—120 Vac Internal Transformers for Series 2 Motors
- 4074ERU—Weatherproofing kit. Protects motor from driving rain when mounted in any position
- 221455A—Infinitely adjustable Motor Crank Arm

FEATURES

- Fixed torque throughout the entire voltage range.
- Integral spring return returns motor to normal position when power is interrupted.
- Integral junction box provides NEMA 3 weather protection if motor is mounted in the upright position.
- Motor and circuitry operate from 24 Vac.
- Quick-connect terminals are standard--screw terminal adapter is available.
- Adapter bracket for matching shaft height of older motors is available.
- Motors have field adjustable stroke (90 to 160 degrees).
- Motors are designed for either normally open or normally closed valves and dampers.
- Integral auxiliary switches are available factory mounted, or can be field added.
- Motors can operate valve linkages from the power end or auxiliary end shafts for normally closed or normally open valve applications.
- All models have dual shafts (slotted and tapped on both ends).

DIMENSIONS DIAGRAM

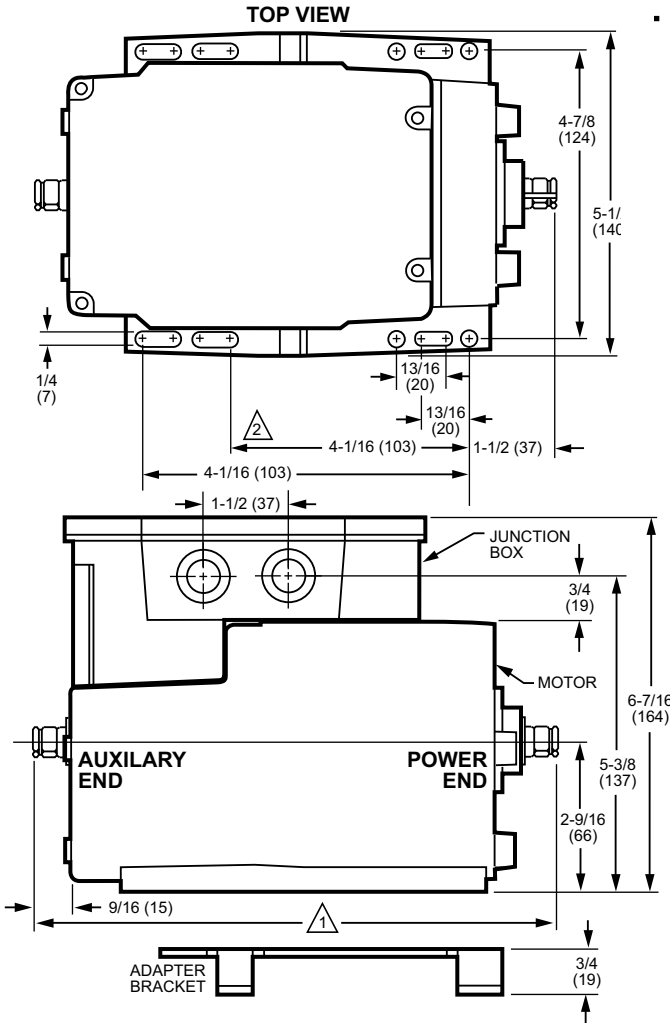

SUBMITTAL SHEETS

Modutrol IV Motor

M6184; M6194



Series 61 Modutrol IV™ Motors non-spring return floating control motors used with controllers that provide a switched SPDT or floating output to operate dampers or valves.

FEATURES

- Integral junction box provides NEMA 3 weather protection if motor is mounted in the upright position.
- Motor and circuitry operate from 24 Vac.
- Quick-connect terminals are standard--screw terminal adapter is available.
- Adapter bracket for matching shaft height of older motors is available.
- Motors have field adjustable stroke (90 to 160 degrees).
- Integral auxiliary switches are available factory mounted, or can be field added.
- All models have dual shafts (slotted and tapped on both ends).
- All models have auxiliary switch cams.
- Fixed torque throughout the entire voltage range.
- Motors are designed for either normally open or normally closed valves and dampers.

SPECIFICATIONS

Application Type	Damper; Valve
Fail Safe Mode	Non-Spring Return
Control Signal	Floating
Torque/Force	75 lb-in. (8.5 Nm) or 150 lb-in. (17 Nm) or 300 lb-in. (34 Nm)
External Auxiliary Switches Available ..	Yes
Auxiliary Switch Ratings	
AFL - 120 Vac	7.2A
Auxiliary Switch Ratings	
ALR - 120 Vac	43.2A
Auxiliary Switch Ratings	
AFL - 240 Vac	3.6A
Auxiliary Switch Ratings	
ALR - 240 Vac	21.6A
Feedback	No
Electrical Connections	Quick-connect terminals
Frequency	50 Hz, 60 Hz
Mounting	Foot-mounted
Motor Shafts	Dual-ended shaft
Shaft Shape	Square
Shaft Dimensions	0.375 in. (10 mm)
Deadweight Load on Shaft (Either End)	200 lb.
Deadweight Load (Combined on both Shafts)	300 lb.
Ambient Temperature Range	-40 F to 150 F (-40 C to 60 C)
Weight	6.5 lb

APPROVALS

Canadian Standards Association	Certified: File No. LR1620, Guide No. 400-E
CE	EN55011 (Emission) EN50082- 2 (Immunity) 73/23/EEC (LVD)
Underwriters Laboratories, Inc.	Listed File: E4436, Guide: XAPX2

ACCESSORIES

- Q7230A1005—Interface module, provides adjustable zero & span, voltage or current control
- 220736A—Internal Auxiliary Switch Assembly - 1 Switch
- 220736B—Internal Auxiliary Switch Assembly - 2 Switches
- 50017460-001—24/120/230 Vac Internal Transformers for Series 2 Motors
- 50017460-003—120 Vac Internal Transformers for Series 2 Motors
- 4074ERU—Weatherproofing kit. Protects motor from driving rain when mounted in any position
- 221455A—Infinitely adjustable Motor Crank Arm

DIMENSIONS DIAGRAM

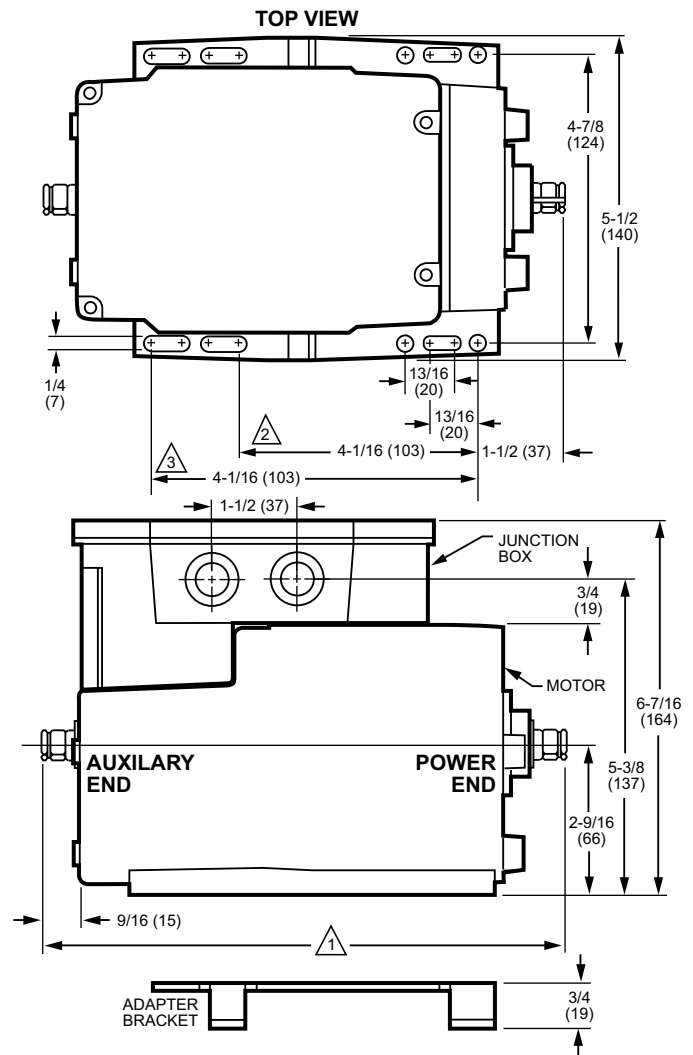

M6285 for slaving applications



Series 62 Modutrol IV™ Motors are spring return floating control motors used with controllers that provide a switched SPDT or floating output to operate dampers or valves. These motors also have an internal electrically isolated feedback potentiometer that provides indication of the motor shaft position and can be used for slaving Series 90 motors or rebalancing an external control circuit.

SPECIFICATIONS

Application Type	Damper; Valve
Fail Safe Mode	Spring Return
Control Signal	Floating
Torque/Force	60 lb-in. (6.8 Nm)
External Auxiliary Switches Available ..	Yes
Auxiliary Switch Ratings	
AFL - 120 Vac	7.2A
Auxiliary Switch Ratings	
ALR - 120 Vac	43.2A
Auxiliary Switch Ratings	
AFL - 240 Vac	3.6A
Auxiliary Switch Ratings	
ALR - 240 Vac	21.6A
Feedback	Yes
Electrical Connections	Quick-connect terminals
Frequency	50 Hz, 60 Hz
Mounting	Foot-mounted
Motor Shafts	Dual-ended shaft
Shaft Shape	Square
Shaft Dimensions	0.375 in. (10 mm)
Deadweight Load on Shaft (Either End)	200 lb.
Deadweight Load (Combined on both Shafts)	300 lb.
Ambient Temperature Range	-40 F to 150 F (-40 C to 60 C)
Weight	8.5 lb

APPROVALS

Canadian Standards Association	Certified: File No. LR1620, Guide No. 400-E
CE	EN55011 (Emission) EN50082- 2 (Immunity) 73/23/EEC (LVD)
Underwriters Laboratories, Inc.	Listed File: E4436, Guide: XAPX

ACCESSORIES

- Q7230A1005—Interface module, provides adjustable zero & span, voltage or current control
- 220736A—Internal Auxiliary Switch Assembly - 1 Switch
- 220736B—Internal Auxiliary Switch Assembly - 2 Switches
- 50017460-001—24/120/230 Vac Internal Transformers for Series 2 Motors
- 50017460-003—120 Vac Internal Transformers for Series 2 Motors
- 4074ERU—Weatherproofing kit. Protects motor from driving rain when mounted in any position
- 221455A—Infinitely adjustable Motor Crank Arm

FEATURES

- Integral junction box provides NEMA 3 weather protection.
- Integral spring return returns motor to normal position when power is interrupted.
- Motor and circuitry operate from 24 Vac.
- Quick-connect terminals are standard--screw terminal adapter is available.
- Adapter bracket for matching shaft height of older motors is available.
- Motors have field adjustable stroke (90 to 160 degrees).
- Integral auxiliary switches are available factory mounted, or can be field added.
- Spring return motors can operate valve linkages from power end or auxiliary end shafts for normally closed or normally open valve applications.
- All models have dual shafts (slotted and tapped on both ends).
- All models have auxiliary switch cams.
- Fixed torque throughout the entire voltage range.
- Motors are designed for either normally open or normally closed valves and dampers.
- Include electrically isolated feedback potentiometer that provides shaft position indication.
- -S models with non-linear feedback are for slaving applications only.

DIMENSIONS DIAGRAM

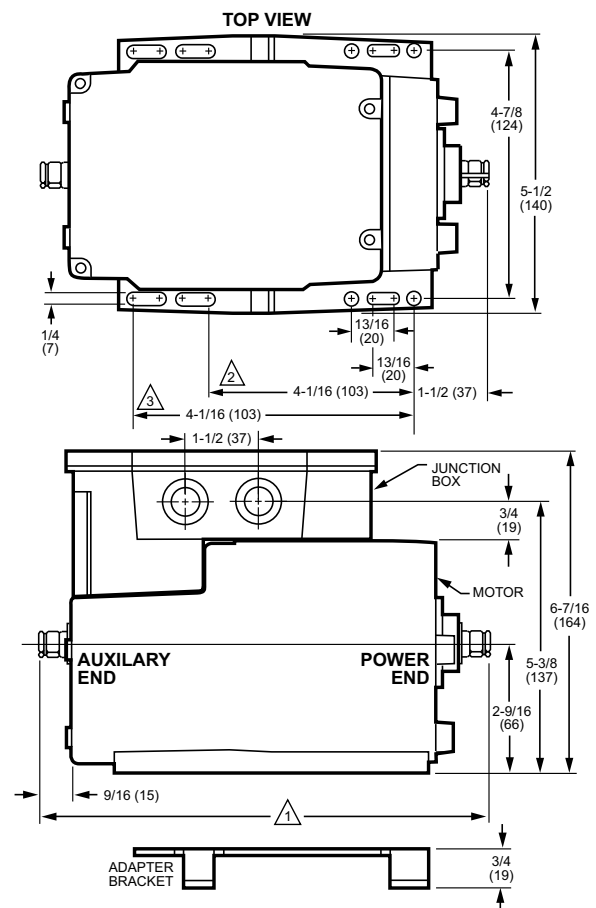

Modutrol IV Motor

M6284; M6294 for slaving applications



These Series 62 Modutrol IV™ Motors non-spring return floating control motors are used with controllers that provide a switched SPDT or floating output to operate dampers or valves. These motors also have an internal electrically isolated feedback potentiometer that provides indication of the motor shaft position. Some models can be used for slaving Series 90 Motors.

SPECIFICATIONS

Application Type	Damper; Valve
Fail Safe Mode	Non-Spring Return
Control Signal	Floating
Torque/Force	150 lb-in. (17 Nm) or 300 lb-in. (34 Nm)
External Auxiliary Switches Available ..	Yes
Auxiliary Switch Ratings	
AFL - 120 Vac	7.2A
Auxiliary Switch Ratings	
ALR - 120 Vac	43.2A
Auxiliary Switch Ratings	
AFL - 240 Vac	3.6A
Auxiliary Switch Ratings	
ALR - 240 Vac	21.6A
Feedback	Yes
Electrical Connections	Quick-connect terminals
Frequency	50 Hz, 60 Hz
Mounting	Foot-mounted
Motor Shafts	Dual-ended shaft
Shaft Shape	Square
Shaft Dimensions	0.375 in. (10 mm)
Deadweight Load on Shaft (Either End)	200 lb.
Deadweight Load (Combined on both Shafts)	300 lb.
Ambient Temperature Range	-40 F to 150 F (-40 C to 60 C)
Weight	7.5 lb

APPROVALS

Canadian Standards Association	Certified: File No. LR1620, Guide No. 400-E
CE	EN55011 (Emission) EN50082- 2 (Immunity) 73/23/EEC (LVD)
Underwriters Laboratories, Inc.	Listed File: E4436, Guide: XAPX

ACCESSORIES

- Q7230A1005—Interface module, provides adjustable zero & span, voltage or current control
- 220736A—Internal Auxiliary Switch Assembly - 1 Switch
- 220736B—Internal Auxiliary Switch Assembly - 2 Switches
- 50017460-001—24/120/230 Vac Internal Transformers for Series 2 Motors
- 50017460-003—120 Vac Internal Transformers for Series 2 Motors
- 4074ERU—Weatherproofing kit. Protects motor from driving rain when mounted in any position
- 221455A—Infinitely adjustable Motor Crank Arm

FEATURES

- Integral junction box provides NEMA 3 weather protection if motor is mounted in the upright position.
- Motor and circuitry operate from 24 Vac.
- Quick-connect terminals are standard--screw terminal adapter is available.
- Adapter bracket for matching shaft height of older motors is available.
- Motors have field adjustable stroke (90 to 160 degrees).
- Integral auxiliary switches are available factory mounted, or can be field added.
- All models have dual shafts (slotted and tapped on both ends).
- All models have auxiliary switch cams.
- Fixed torque throughout the entire voltage range.
- Motors are designed for either normally open or normally closed valves and dampers.
- Include electrically isolated feedback potentiometer that provides shaft position indication.
- -S models with non-linear feedback are for slaving applications only.

DIMENSIONS DIAGRAM

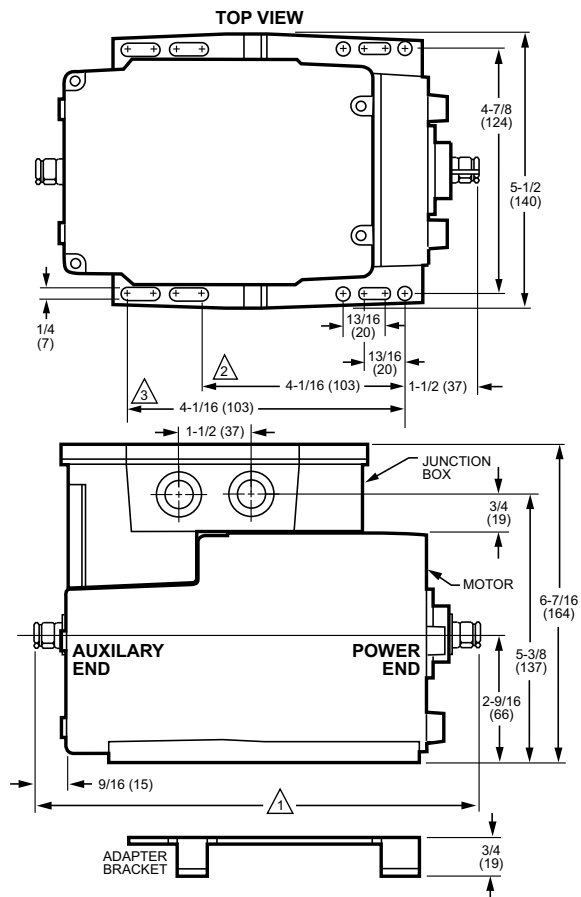

M6274; M6284; M6285; M6294 Motors with Linear 10K Feedback



Series 62 Modutrol IV™ Motors spring return and non-spring return floating control motors used with controllers that provide a switched SPDT or floating output to operate dampers or valves. These motors also have an internal electrically isolated feedback potentiometer that provides indication of the motor shaft position.

SPECIFICATIONS

Application Type	Damper; Valve
Fail Safe Mode	Spring Return or Non-Spring Return
Control Signal	Floating
Torque/Force	60 lb-in. (6.8 Nm) or 75 lb-in. (8.5 Nm) or 150 lb-in. (17 Nm) or 300 lb-in. (34 Nm)
External Auxiliary Switches Available ..	Yes
Auxiliary Switch Ratings	
AFL - 120 Vac	7.2A
Auxiliary Switch Ratings	
ALR - 120 Vac	43.2A
Auxiliary Switch Ratings	
AFL - 240 Vac	3.6A
Auxiliary Switch Ratings	
ALR - 240 Vac	21.6A
Feedback	Yes
Electrical Connections	Screw terminals
Frequency	50 Hz; 60 Hz
Mounting	Foot-mounted
Motor Shafts	2; Dual-ended shaft
Shaft Shape	Square
Shaft Dimensions	0.375 in. (10 mm)
Deadweight Load on Shaft (Either End)	200 lb.
Deadweight Load (Combined on both Shafts)	300 lb.
Ambient Temperature Range	-40 F to 150 F (-40 C to 60 C)
Weight	6.5 lb

APPROVALS

Canadian Standards Association	Certified: File No. LR1620, Guide No. 400-E
CE	EN55011 (Emission) EN50082-2 (Immunity) 73/23/EEC (LVD)
Underwriters Laboratories, Inc.	Listed File: E4436, Guide: XAPX

ACCESSORIES

- Q7230A1005—Interface module, provides adjustable zero & span, voltage or current control
- 220736A—Internal Auxiliary Switch Assembly - 1 Switch
- 220736B—Internal Auxiliary Switch Assembly - 2 Switches
- 50017460-001—24/120/230 Vac Internal Transformers for Series 2 Motors
- 50017460-003—120 Vac Internal Transformers for Series 2 Motors
- 4074ERU—Weatherproofing kit. Protects motor from driving rain when mounted in any position
- 221455A—Infinitely adjustable Motor Crank Arm

FEATURES

- Integral junction box provides NEMA 3 weather protection if motor is mounted in the upright position.
- Motor and circuitry operate from 24 Vac.
- Quick-connect terminals are standard--screw terminal adapter is available.
- Adapter bracket for matching shaft height of older motors is available.
- Motors have field adjustable stroke (90 to 160 degrees).
- Integral auxiliary switches are available factory mounted, or can be field added.
- All models have dual shafts (slotted and tapped on both ends).
- All models have auxiliary switch cams.
- Fixed torque throughout the entire voltage range.
- Motors are designed for either normally open or normally closed valves and dampers.
- Include electrically isolated feedback potentiometer that provides shaft position indication.
- -F models have an internal electrically isolated feedback potentiometer that provides indication of the motor shaft position.

DIMENSIONS DIAGRAM

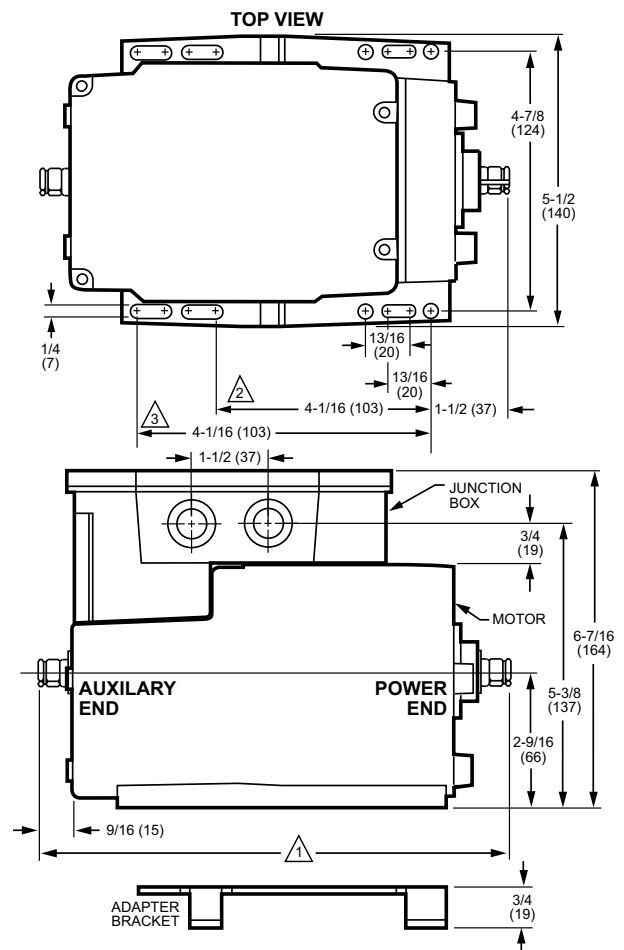

Modutrol IV Motor

M7164



Series 71 Modutrol IV™ Motors non-spring return motors used to control dampers and valves. These motors accept a voltage signal from an electronic controller to position a damper or valve at any point between open and closed.

FEATURES

- Integral junction box provides NEMA 3 weather protection if motor is mounted in the upright position.
- Motor and circuitry operate from 24 Vac.
- Quick-connect terminals are standard--screw terminal adapter is available.
- Adapter bracket for matching shaft height of older motors is available.
- Motors have field adjustable stroke (90 to 160 degrees).
- Integral auxiliary switches are available factory mounted, or can be field added.
- All models have dual shafts (slotted and tapped on both ends).
- All models have auxiliary switch cams.
- Fixed torque throughout the entire voltage range.

SPECIFICATIONS

Application Type	Damper; Valve
Fail Safe Mode	Non-Spring Return
Control Signal	Modulating, 10.5-13.5 Vdc
Torque/Force	60 lb-in. (6.8 Nm)
External Auxiliary Switches Available ..	Yes
Auxiliary Switch Ratings	
AFL - 120 Vac	7.2A
ALR - 120 Vac	43.2A
Auxiliary Switch Ratings	
AFL - 240 Vac	3.6A
ALR - 240 Vac	21.6A
Feedback	No
Electrical Connections	Quick-connect terminals
Frequency	50 Hz, 60 Hz
Mounting	Foot-mounted
Motor Shafts	Dual-ended shaft
Shaft Shape	Square
Shaft Dimensions	0.375 in. (10 mm)
Deadweight Load on Shaft (Either End)	200 lb.
Deadweight Load (Combined on both Shafts)	300 lb.
Ambient Temperature Range	-40 F to 150 F (-40 C to 60 C)
Weight	6.5 lb

APPROVALS

Canadian Standards Association	Certified: File No. LR1620, Guide No. 400-E
CE	EN55011 (Emission) EN50082- 2 (Immunity) 73/23/EEC (LVD)
Underwriters Laboratories, Inc.	Listed File: E4436, Guide: XAPX

ACCESSORIES

- Q7230A1005—Interface module, provides adjustable zero & span, voltage or current control
- 220736A—Internal Auxiliary Switch Assembly - 1 Switch
- 220736B—Internal Auxiliary Switch Assembly - 2 Switches
- 50017460-001—24/120/230 Vac Internal Transformers for Series 2 Motors
- 50017460-003—120 Vac Internal Transformers for Series 2 Motors
- 4074ERU—Weatherproofing kit. Protects motor from driving rain when mounted in any position
- 221455A—Infinitely adjustable Motor Crank Arm

DIMENSIONS DIAGRAM

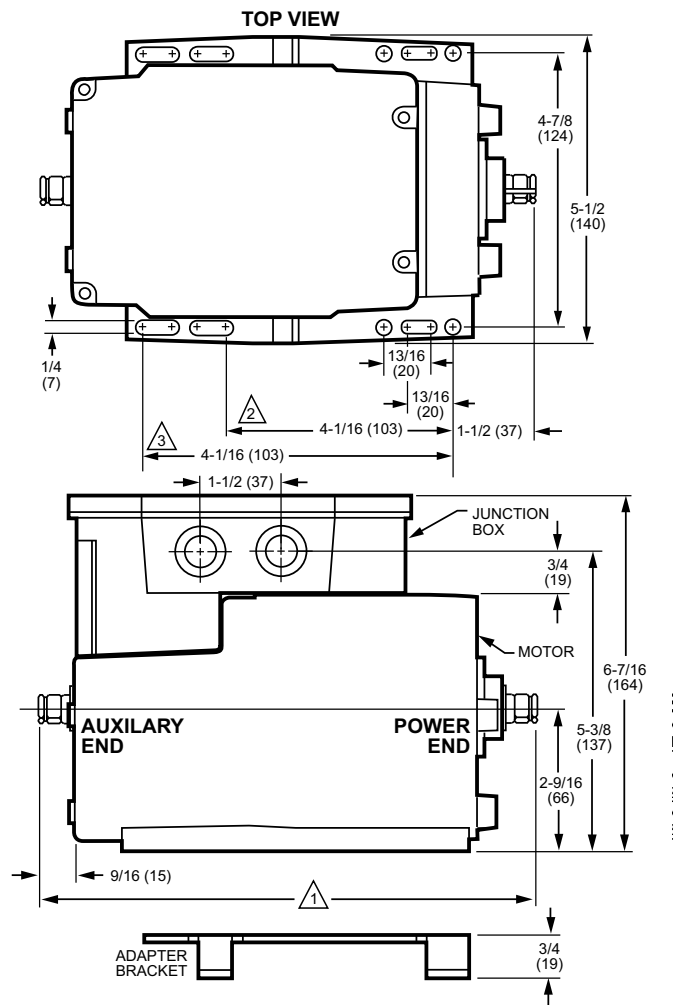

Modutrol IV Motor

M7274; M7284; M7285; M7286; M7294



The Series 72 Modutrol IV Motors spring return and non-spring return motors are used to control dampers and valves. The motors accept a current or voltage signal from an electronic controller to position a damper or valve at any point between open and closed.

SPECIFICATIONS

Application Type	Damper; Valve
Fail Safe Mode	Spring Return or Non-Spring Return
Control Signal	Modulating, 4-20 mA
Torque/Force	60 lb-in. (6.8 Nm) or 75 lb-in. (8.5 Nm) or 150 lb-in. (17 Nm) or 300 lb-in. (34 Nm)
External Auxiliary Switches Available ..	Yes
Auxiliary Switch Ratings	
AFL - 120 Vac	7.2A
Auxiliary Switch Ratings	
ALR - 120 Vac	43.2A
Auxiliary Switch Ratings	
AFL - 240 Vac	3.6A
Auxiliary Switch Ratings	
ALR - 240 Vac	21.6A
Feedback	No
Electrical Connections	Screw terminals
Frequency	50 Hz, 60 Hz
Mounting	Foot-mounted
Motor Shafts	Dual-ended shaft
Shaft Shape	Square
Shaft Dimensions	0.375 in. (10 mm)
Deadweight Load on Shaft (Either End)	200 lb.
Deadweight Load (Combined on both Shafts)	300 lb.
Ambient Temperature Range	-40 F to 150 F (-40 C to 60 C)
Weight	7 lb

APPROVALS

Canadian Standards Association	Certified: File No. LR1620, Guide No. 400-E
Underwriters Laboratories, Inc.	Listed File: E4436, Guide: XAPX

ACCESSORIES

- Q7230A1005—Interface module, provides adjustable zero & span, voltage or current control
- 220736A—Internal Auxiliary Switch Assembly - 1 Switch
- 220736B—Internal Auxiliary Switch Assembly - 2 Switches
- 50017460-001—24/120/230 Vac Internal Transformers for Series 2 Motors
- 50017460-003—120 Vac Internal Transformers for Series 2 Motors
- 4074ERU—Weatherproofing kit. Protects motor from driving rain when mounted in any position
- 221455A—Infinitely adjustable Motor Crank Arm

FEATURES

- Integral spring return returns motor to normal position when power is interrupted.
- Integral junction box provides NEMA 3 weather protection if motor is mounted in the upright position.
- Motor and circuitry operate from 24 Vac.
- Quick-connect terminals are standard--screw terminal adapter is available.
- Adapter bracket for matching shaft height of older motors is available.
- Motors have field adjustable stroke (90 to 160 degrees).
- Integral auxiliary switches are available factory mounted, or can be field added.
- Spring return motors can operate valve linkages from power end or auxiliary end shafts for normally closed or normally open valve applications.
- All models have dual shafts (slotted and tapped on both ends).
- All models have auxiliary switch cams.
- Fixed torque throughout the entire voltage range.
- Motors are designed for either normally open or normally closed valves and dampers.
- Models available with adjustable start (zero) and span.
- Models available with 4 to 20 mA input signal.
- Models available with 2 to 10 Vdc input signal.
- Die-cast aluminum housing.

DIMENSIONS DIAGRAM

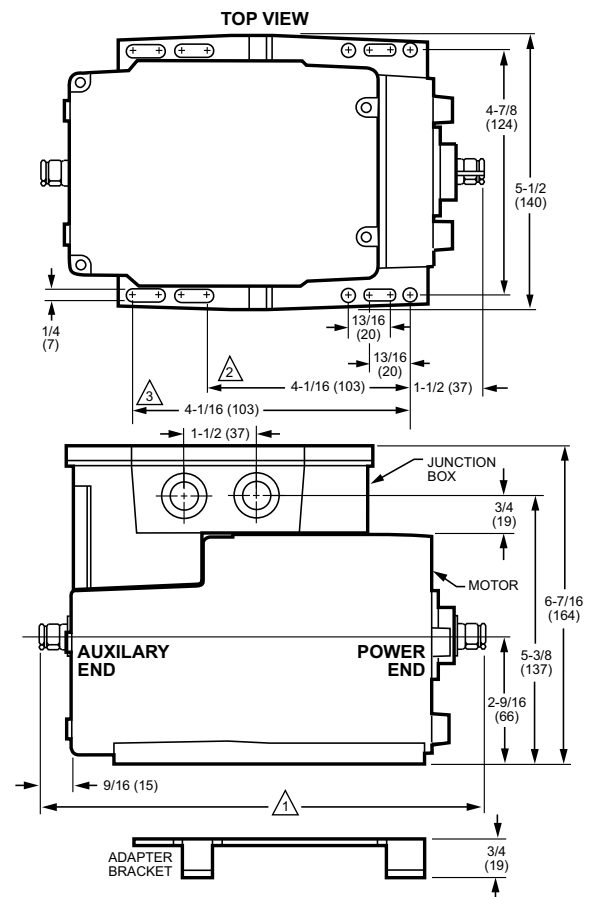

SUBMITTAL SHEETS

Modutrol IV Motor

M9164; M9174; M9182; M9184; M9194



Series 90 Modutrol IV™ Motors non-spring return modulating proportional control motors used with controllers that provide a Series 90 output to operate dampers or valves.

FEATURES

- Integral junction box provides NEMA 3 weather protection if motor is mounted in the upright position.
- Motor and circuitry operate from 24 Vac.
- Quick-connect terminals are standard--screw terminal adapter is available.
- Adapter bracket for matching shaft height of older motors is available.
- Motors have field adjustable stroke (90 to 160 degrees).
- Integral auxiliary switches are available factory mounted, or can be field added.
- All models have dual shafts (slotted and tapped on both ends).
- All models have auxiliary switch cams.
- Fixed torque throughout the entire voltage range.

SPECIFICATIONS

Application Type	Damper
Fail Safe Mode	Non-Spring Return
Control Signal	Proportional, 135 ohm
Torque/Force	60 lb-in. (6.8 Nm) or 75 lb-in. (8.5 Nm) or 150 lb-in. (17 Nm) or 300 lb-in. (34 Nm)
External Auxiliary Switches Available ..	Yes
Auxiliary Switch Ratings	
AFL - 120 Vac	7.2A
Auxiliary Switch Ratings	
ALR - 120 Vac	43.2A
Auxiliary Switch Ratings	
AFL - 240 Vac	3.6A
Auxiliary Switch Ratings	
ALR - 240 Vac	21.6A
Feedback	No
Electrical Connections	Quick-connect terminals
Frequency	50 Hz, 60 Hz
Mounting	Foot-mounted
Motor Shafts	Dual-ended shaft
Shaft Shape	Square
Shaft Dimensions	0.375 in. (10 mm)
Deadweight Load on Shaft (Either End)	200 lb.
Deadweight Load (Combined on both Shafts)	300 lb.
Ambient Temperature Range	-40 F to 150 F (-40 C to 60 C)
Weight	7.5 lb

APPROVALS

Canadian Standards Association	Certified: File No. LR1620, Guide No. 400-E
CE	EN55011 (Emission) EN50082- 2 (Immunity) 73/23/EEC (LVD)
Underwriters Laboratories, Inc.	Listed File: E4436, Guide: XAPX

ACCESSORIES

- Q7230A1005—Interface module, provides adjustable zero & span, voltage or current control
- 220736A—Internal Auxiliary Switch Assembly - 1 Switch
- 220736B—Internal Auxiliary Switch Assembly - 2 Switches
- 50017460-001—24/120/230 Vac Internal Transformers for Series 2 Motors
- 50017460-003—120 Vac Internal Transformers for Series 2 Motors
- 4074ERU—Weatherproofing kit. Protects motor from driving rain when mounted in any position
- 221455A—Infinitely adjustable Motor Crank Arm

DIMENSIONS DIAGRAM

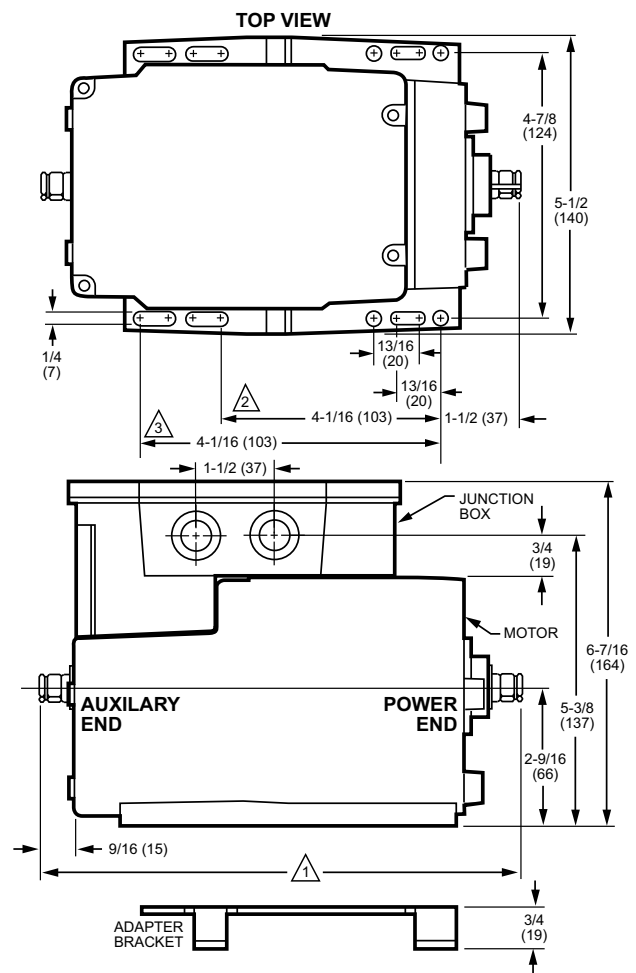

Modutrol IV Motor

M9175; M9185; M9186



Series 90 Modutrol™ IV Motors spring return modulating proportional control motors used with controllers that provide a Series 90 output to operate dampers or valves.

FEATURES

- Integral junction box provides NEMA 3 weather protection if motor is mounted in the upright position.
- Integral spring return returns motor to normal position when power is interrupted.
- Motor and circuitry operate from 24 Vac.
- Quick-connect terminals are standard; screw terminal adapter is available.
- Adapter bracket for matching shaft height of older motors is available.
- Motors have field adjustable stroke (90 to 160 degrees).
- Integral auxiliary switches are available factory mounted, or can be field added.
- Spring return motors can operate valve linkages from power end or auxiliary end shafts for normally closed or normally open valve applications.
- All models have dual shafts (slotted and tapped on both ends).
- All models have auxiliary switch cams.
- Fixed torque throughout the entire voltage range.

SPECIFICATIONS

Application Type	Damper; Valve
Fail Safe Mode	Spring Return
Control Signal	Proportional, 135 ohm
Torque/Force	60 lb-in. (6.8 Nm)
External Auxiliary Switches Available ..	Yes
Auxiliary Switch Ratings	
AFL - 120 Vac	7.2A
ALR - 120 Vac	43.2A
Auxiliary Switch Ratings	
AFL - 240 Vac	3.6A
ALR - 240 Vac	21.6A
Feedback	No
Electrical Connections	Quick-connect terminals
Frequency	50 Hz, 60 Hz
Mounting	Foot-mounted
Motor Shafts	Dual-ended shaft
Shaft Shape	Square
Shaft Dimensions	0.375 in. (10 mm)
Deadweight Load on Shaft (Either End)	200 lb.
Deadweight Load (Combined on both Shafts)	300 lb.
Ambient Temperature Range	-40 F to 150 F (-40 C to 60 C)
Weight	8.5 lb

APPROVALS

Canadian Standards Association	Certified: File No. LR1620, Guide No. 400-E
Underwriters Laboratories, Inc.	Listed File: E4436, Guide: XAPX

ACCESSORIES

- Q7230A1005—Interface module, provides adjustable zero & span, voltage or current control
- 220736A—Internal Auxiliary Switch Assembly - 1 Switch
- 220736B—Internal Auxiliary Switch Assembly - 2 Switches
- 50017460-001—24/120/230 Vac Internal Transformers for Series 2 Motors
- 50017460-003—120 Vac Internal Transformers for Series 2 Motors
- 4074ERU—Weatherproofing kit. Protects motor from driving rain when mounted in any position
- 221455A—Infinitely adjustable Motor Crank Arm

DIMENSIONS DIAGRAM

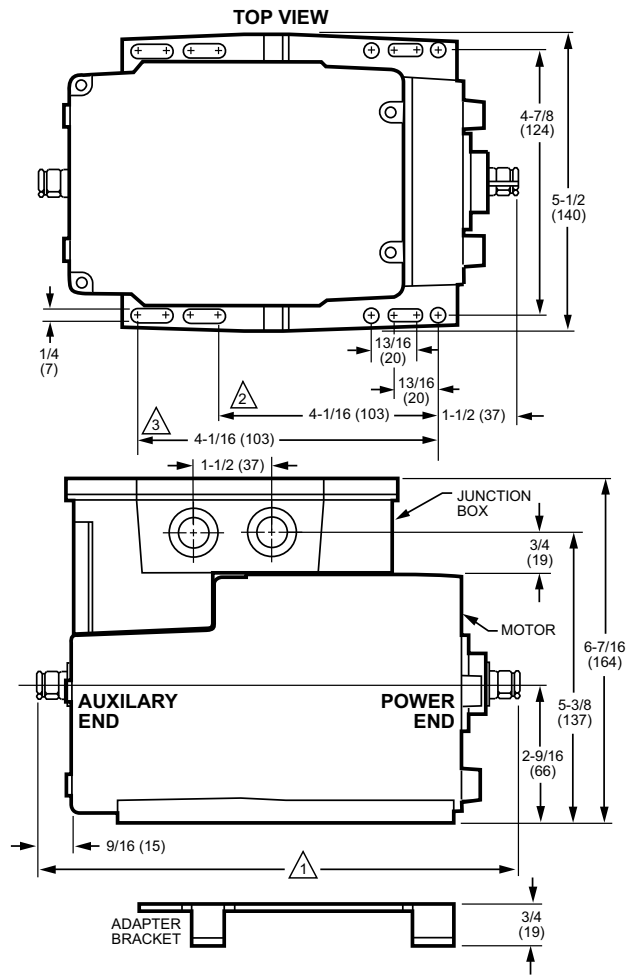

SUBMITTAL SHEETS

Modutrol IV Motor

Q7130; Q7230; Q7330



For converting Series 90 Modutrol IV motors to Series 70 (electronic) control.

FEATURES

- Mounts and works inside wiring box of any series 90 Modutrol IV Motor.
- Protected from weather by motor's NEMA 3 wiring box.
- Mates to motor's quick-connect terminals and provides screw terminals for control wiring connections.
- Features solid-state circuitry with surface mount components.
- Cover holds module in place, screws not required.
- Includes (except Q7330A) reversing switch to allow replacement of electrically normally open or electrically normally closed motors.

SPECIFICATIONS

Application Type	Damper
Dimensions, Approximate	Fits inside wiring junction box of Modutrol IV Motor
Control Signal	Provides selectable voltage ranges: 4 to 7, 6 to 9, or 10.5 to 13.5 Vdc. Adapts M91XX to function as M71XX model
Electrical Connections	Terminal Board
Frequency	50 Hz; 60 Hz
Mounting	Mounts to quick-connects inside Mod Motor
Ambient Temperature Range	-40 F to 150 F (-40 C to 60 C)
Weight	0.3 lb

Unitary Valve Actuator

VU443, VU444; VU843; VU844



The VU844 Fan Coil Valve Actuators are used in conjunction with the VU52, VU53 and VU54 valves for controlling the flow of hot or chilled water in commercial HVAC equipment such as fan coil units, terminal reheat coils and convectors. These valves are humidity resistant and are suitable for use in condensing, non-corrosive environments.

FEATURES

- Compact construction for easy installation.
- Fits under the cover of most baseboard convectors with actuator fitted to valve body.
- One-button, quick release. Secure 3-point, metal latch to valve body.
- Spring return operation.
- Stainless steel case and aluminum cover. Rust-proof nickel-plated motors available.
- Line or low voltage, rust-resistant motors.
- Manual opener for installation and valve operation on power failure.
- Valve returns to automatic position when power is restored.
- Actuator may be reinstalled or serviced without draining the system or disassembling the valve.
- Slotted conduit hole for faster wiring.

SPECIFICATIONS

Actuator Type	Valve
Control Signal	SPST
Fail Safe Mode	Spring Return
Electrical Connections	Leads
Electrical Connection Length	6 in.
Frequency	60 Hz
Manual operation	Lever
Stroke	22 deg. (24 grad.)
Supply Voltage	24V, 120V, 208V, 240V, or 277 Vac
Materials	Stainless Steel Case, Aluminum Cover, Nickel-plated motors available
Medium Temperature	200 F (94 C)
Ambient Temperature Range	34 F to 125 F ambient at 200 F Fluid (1 C to 52 C ambient at 93 C Fluid)

APPROVALS

Canadian Standards Association Certified C/US

DIMENSIONS DIAGRAM

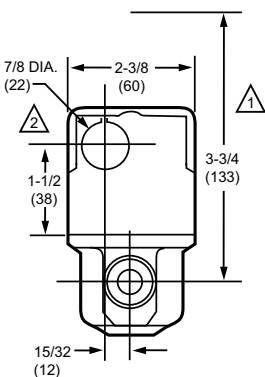

VU53 VALVE WITH VU448 ACTUATOR

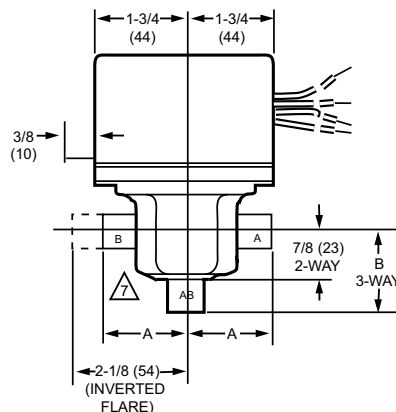

VU53 AND VU54 VALVE WITH ACTUATOR

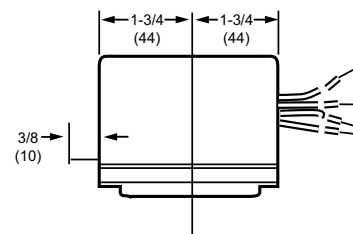

VU5 ACTUATOR

- △1 HEIGHT NEEDED TO REMOVE ACTUATOR OR COVER
- △2 OPENING FOR 1/2 IN. CONDUIT ON OPPOSITE SITE OF MANUAL LEVER FOR ALL MODELS.

VALVE BODY SIZE	A	B
1/2 IN. SWEAT	1-5/6 (33)	1-5/6 (33)
3/4 IN. SWEAT	1-3/8 (35)	1-11/16 (43)
1 IN. SWEAT	1-11/16 (43)	1-11/16 (43)
1/2 IN. NPT	1-3/8 (35)	1-5/16 (33)
3/4 IN. NPT	1-11/16 (43)	1-7/16 (37)

M18261

Unitary Valve Actuator

VC Series Two-position Actuators



Control central heating and/or cooling systems, fan coil systems, radiators and convectors. Depending on the model selected, it can be controlled by either a low or line voltage SPST controller such as a room thermostat.

FEATURES

- Use with two-way or three-way valves.
- Minimal actuator power consumption.
- Double insulated actuator.
- Quick-connect or one meter cable electrical connections available.
- Quick and easy replacement of moving parts.
- Actuator head installation does not require draining the system.
- On/Off models with six second nominal timing
- Use two-position actuators with 1000 Series 2-way and 6000 Series 3-way VC valve bodies only.
- All VC Series actuator-valve combinations provide 60 psi close-off.

SPECIFICATIONS

Actuator Type	Valve
Control Signal	24 Vac, 100-130 Vac, or 200-240 Vac
Fail Safe Mode	Stays in place
Electrical Protection	Double Insulated
Ingress Protection Rating	IP40
Electrical Connections	Plenum-rated cable (24 V); cable (line voltage)
Frequency	60 Hz
Manual operation	Lever
Mounting	Direct Coupled
Shaft Adapter Type	Self-alignment
Stroke	0.4 in. (10 mm)
Supply Voltage	24 Vac; 100-130 Vac; or 200-240 Vac 3-wire.
Timing, Nominal Driving at 60 Hz	6 sec.
Power Consumption, Driving	6 VA
Materials	Plastic housing
Operating Humidity Range (% RH)	5 to 95% RH, non-condensing
Medium Temperature	203 F (95 C)
Ambient Temperature Range	32 F to 150 F (0 C to 65 C)
Temperature Ratings (Shipping)	-40 F to 150 F (-40 C to 65 C)
Storage Temperature Range	-40 F to 150 F (-40 C to 65 C)
Weight	0.57 lb (0.26 kg)
Includes	3/8 in. flex conduit adapter (24 V models)

APPROVALS

Canadian Standards Association	CSA Certified: LR1322-367
CE	89/336/ECC, 73/23/EEC
Underwriters Laboratories, Inc.	UL Recognized, File# MH11826

Unitary Valve Actuator

VC Series Proportional Actuators



Control central heating and/or cooling systems, fan coil systems, radiators and convectors. Depending on the model selected, it can be controlled by either a low or line voltage SPST or SPDT or floating controller such as a room thermostat, Aquastat control, flow switch or a 0/2 to 10 Vdc controller.

FEATURES

- Use with two-way or three-way valves.
- Minimal actuator power consumption.
- Double insulated actuator.
- Quick-connect or one meter cable electrical connections available.
- Quick and easy replacement of moving parts.
- Actuator head installation does not require draining the system.
- Use non-fail safe proportional actuators with 3000 Series 2-way and 7000 Series 3-way VC valve bodies only.
- All VC Series actuator-valve combinations provide 60 psi close-off.

SPECIFICATIONS

Actuator Type	Valve
Control Signal	2-10 Vdc modulating; or 24 Vac floating
Fail Safe Mode	Stays in place
Cable Entry	Molded strain relief, conduit clamp
Electrical Protection	Double Insulated
Ingress Protection Rating	IP40
Electrical Connections	Plenum-rated cable
Electrical Connection Length	5 ft. plenum rated (1.5 m plenum rated)
Frequency	50 Hz, 60 Hz
Manual operation	Lever
Mounting	Direct Coupled
Shaft Adapter Type	Self-alignment
Stroke	0.4 in. (10 mm)
Supply Voltage	24 Vac
Timing, Nominal Driving at 60 Hz	120 sec.
Power Consumption, Driving	6 VA
Materials	Plastic housing
Operating Humidity Range (% RH)	5 to 95% RH, non-condensing
Medium Temperature	203 F (95 C)
Ambient Temperature Range	32 F to 150 F (0 C to 65 C)
Temperature Ratings (Shipping)	-40 F to 150 F (-40 C to 65 C)
Storage Temperature Range	-40 F to 150 F (-40 C to 65 C)
Weight	0.84 lb (0.38 kg)
Includes	3/8 in. flex conduit adapter
Comments	Use with 3000 Series 2-way and 7000 Series VC valve bodies only

APPROVALS

Canadian Standards Association	CSA Certified: LR1322-367
Underwriters Laboratories, Inc.	Listed 94-5V

Unitary Valve Actuator

VC Series Fail Safe Proportional Actuators



Control central heating and/or cooling systems, fan coil systems, radiators and convectors.

Depending on the model selected, it can be controlled by either a low or line voltage SPST or SPDT or floating or modulating controller such as a room thermostat, Aquastat control, flow switch or a 0/2 to 10 Vdc controller.

FEATURES

- Use with two-way or three-way valves.
- Minimal actuator power consumption.
- Double insulated actuator.
- Five foot plenum-rated cable electrical connections available.
- Quick and easy replacement of moving parts.
- Actuator head installation does not require draining the system.
- Selectable/switchable electronic fail safe normally open or normally closed
- Includes valve bodies.
- All VC Series actuator-valve combinations provide 60 psi close-off.

SPECIFICATIONS

Actuator Type	Valve
Control Signal	2-10 Vdc modulating 24 Vac pulse width modulating 24 Vac floating or 24 Vac on-off
Fail Safe Mode	N.O. or N.C., switchable electronic
Cable Entry	Molded strain relief, conduit clamp
Electrical Protection	Double Insulated
Ingress Protection Rating	IP40
Electrical Connections	Plenum-rated cable
Electrical Connection Length	5 ft. plenum rated (1.5 m plenum rated)
Frequency	50 Hz; 60 Hz
Manual operation	Lever
Mounting	Direct Coupled
Shaft Adapter Type	Self-alignment
Stroke	0.4 in. (10 mm)
Supply Voltage	24 Vac
Timing, Nominal Driving at 60 Hz	60 sec. or 120 sec.
Power Consumption, Driving	12 Watts, 18 VA inrush
Materials	Plastic housing
Operating Humidity Range (% RH)	5 to 95% RH, non-condensing
Medium Temperature	203 F (95 C)
Ambient Temperature Range	32 F to 150 F (0 C to 65 C)
Temperature Ratings (Shipping)	-40 F to 150 F (-40 C to 65 C)
Storage Temperature Range	-40 F to 150 F (-40 C to 65 C)
Weight	0.84 lb (0.38 kg)
Includes	3/8 in. flex conduit adapter, valve body

APPROVALS

Canadian Standards Association	CSA Certified: LR1322-367
CE	89/336/ECC, 73/23/EEC
Underwriters Laboratories, Inc.	Listed 94-5V

Unitary Valve Actuator

M6410; M7410



Cartridge Globe Valve Actuator are small electric actuators for individual room control that provide floating or modulating control of V5852, V5862 two-way or V5853, V5863 three-way valves.

FEATURES

- Suitable for Excel/IRC system or other controllers providing specified signals.
- Magnetic coupling for torque limitation independent of voltage supply and self-adjustment of the close-off port.
- No mounting tools required.
- Small size allows installation in limited space of fan coil units, induction units, and small reheaters or recoolers.
- Visual position indication (red pin).

SPECIFICATIONS

Actuator Type	Valve
Control Signal	Floating; 0-10Vdc or 2-10Vdc modulating
Fail Safe Mode	Stays in place
Cable Entry	Threaded conduit connector
Electrical Protection	Class I Insulation (24 Vac)
Ingress Protection Rating	IP42
Electrical Connections	Plenum-rated cable
Feedback	No
Frequency	50 Hz, 60 Hz
Manual operation	Use valve dust cap
Mounting	Threads onto V58XX valve bonnet
Stroke	1/4 in. (6 mm)
Supply Voltage	20 to 28 Vac
Number of Internal Auxiliary Switch	0
Materials	Low Maintenance Plastic Housing
Operating Humidity Range (% RH)	5 to 95% RH
Medium Temperature	266 F Maximum (130 C Maximum)
Ambient Temperature Range	32 F to 122 F (0 C to 50 C)
Storage Temperature Range	-40 F to 158 F (-40 C to 70 C)
Weight	0.3125 lb (0.15 kg)
Includes	1/2 in. conduit hub

APPROVALS

Underwriters Laboratories, Inc. UL94-5V

DIMENSIONS DIAGRAM

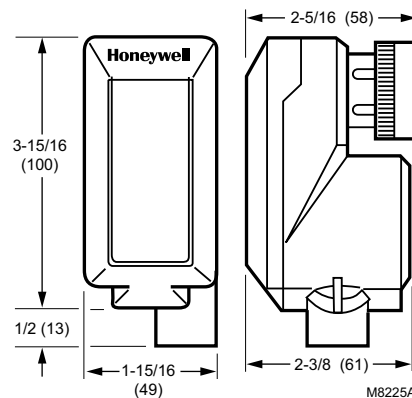

Unitary Valve Actuator

M6435; M7435



Cartridge Globe Valve Spring Return Actuators are small electric actuators for individual room control that provide floating or modulating control of 1/2 and 3/4 in. V5852, V5862 two-way or V5853, V5863 three-way valves.

FEATURES

- Stem actuator retracts up on power failure. Fail safe mode depends on valve seat rest position.
- Suitable for Excel/IRC system or other controllers providing specified signals.
- Magnetic coupling for torque limitation independent of voltage supply and self-adjustment of the close-off port.
- No mounting tools required.
- Compact size allows installation in limited space of fan coil units, induction units, and small reheaters or recoolers.
- Visual position indication (red disk).

SPECIFICATIONS

Actuator Type	Valve
Control Signal	Floating; 0-10 Vdc or 2-10 Vdc modulating
Fail Safe Mode	Spring Return, operator retracts up (Normally open for 1/2 in. and 3/4 in. V5852 and V5862. Normally closed for all other V58XX valves.)
Cable Entry	Threaded conduit connector
Electrical Protection	Class I Insulation (24 Vac)
Ingress Protection Rating	IP54
Electrical Connections	Screw terminals
Feedback	No
Frequency	50 Hz, 60 Hz
Manual operation	Use valve dust cap
Mounting	Threads onto V58XX valve bonnet
Stroke	1/4 in. (6 mm)
Supply Voltage	24 Vac +20%, -15%
Number of Internal Auxiliary Switch	0
Materials	Low Maintenance Plastic Housing
Operating Humidity Range (% RH)	5 to 95% RH
Medium Temperature	266 F Maximum (130 C Maximum)
Ambient Temperature Range	32 F to 122 F (0 C to 50 C)
Storage Temperature Range	-40 F to 158 F (-40 C to 70 C)
Weight	1.1 lb (0.5 kg)
Includes	1/2 in. conduit hub

APPROVALS

Underwriters Laboratories, Inc. UL94-5V

DIMENSIONS DIAGRAM

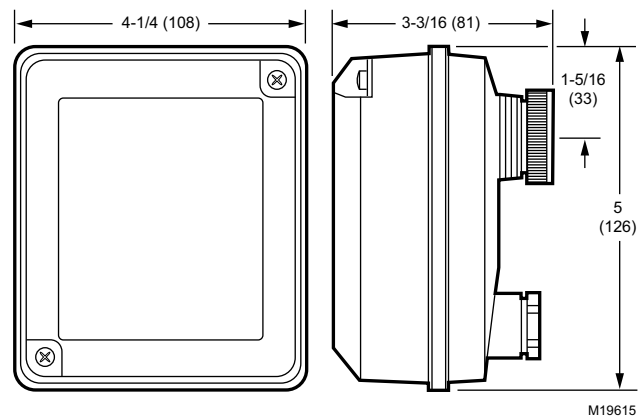

Direct Coupled Valve Actuator

ML6420; ML7420



Direct Coupled Globe Valve Actuators provide floating or modulating control of chilled water, hot water, or steam, and mount directly on VGF series, V5011, and V5013 globe valves from 1/2 to 3 in.

FEATURES

- Easy and quick installation on valves with 1 3/8 in. bonnet and 3/4 in. stroke.
- No separate linkage required.
- Conduit connector standard.
- No adjustments required on linkage.
- Accurate valve positioning.
- Low power consumption.
- High close-off ratings.
- Force limiting end switches.
- Manual operator.
- Synchronous motor.
- Maintenance free.
- ML7420 has an internal selector plug that can be used to reverse the direction of action.

SPECIFICATIONS

Actuator Type	Valve
Control Signal	Floating; 0-10 Vdc or 2-10 Vdc modulating
Fail Safe Mode	Stays in place
(Rated) Stem Force	135 lbf (600 N)
Cable Entry	Conduit connector and one knockout on actuator case
Electrical Protection	Class I Insulation (24 Vac)
Ingress Protection Rating	IP54
Electrical Connections	Screw terminals
Frequency	60 Hz
Manual operation	Knob
Mounting	Directly on V5011/V5013 Globe Valves and VGF Flanged Globe Valves (3/4 in. or 20mm stroke)
Stroke	3/4 in. (20 mm)
Supply Voltage	24 Vac \pm 15%
Materials	ABS-FR Plastic, aluminum yoke
Operating Humidity Range (% RH)	5 to 95% RH
Medium Temperature	300 F Maximum (150 C Maximum)
Ambient Temperature Range	14 F to 122 F (-10 C to +50 C)
Storage Temperature Range	-40 F to 158 F (-40 C to 70 C)
Weight	2.9 lb (1.3 kg)
Includes	1/2 in. conduit hub

APPROVALS

Canadian Standards Association	Certified
CE	Listed
Underwriters Laboratories, Inc.	UL94-5V

ACCESSORIES

- 43191679-111—Potentiometer, 10 K ohm, for ML6425, ML7425
- 43191679-112—Potentiometer, 220 ohm for ML6425, ML7425
- 43191680-105—Dual Auxiliary Switch for CREVAL actuators
- 43196000-001—High Temperature Kit for actuators with 3/4 in. stroke

DIMENSIONS DIAGRAM

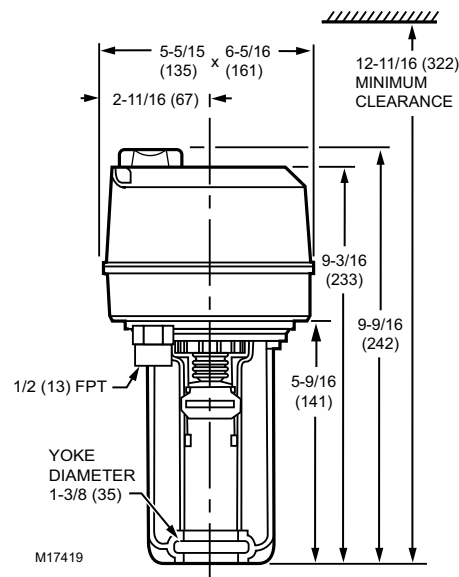

Direct Coupled Valve Actuator

ML6421; ML7421



Direct Coupled Globe Valve Actuators provide floating or modulating control of chilled water, hot water, or steam, and mount directly on VGF series, V5011, and V5013 valves. These Non-Spring Return Actuators will operate 1/2 to 6 in. valves.

FEATURES

- Easy and quick installation on valves with 1 3/8 in. bonnet and 3/4 in. stroke, or with 1 7/8 in. bonnet and 1 1/2 in. stroke.
- High force for VGF Pressure-balanced valves.
- No separate linkage required.
- Conduit connector standard.
- No adjustments required on linkage.
- Accurate valve positioning.
- Low power consumption.
- High close-off ratings.
- Force limiting end switches.
- Manual operator.
- Synchronous motor.
- Maintenance free.

SPECIFICATIONS

Actuator Type	Valve
Control Signal	Floating; 0-10 Vdc or 2-10 Vdc modulating
Fail Safe Mode	Stays in place
(Rated) Stem Force	405 lbf (1800 N)
Cable Entry	Two knockout holes for 1/2 in. conduit standard on actuator case
Electrical Protection	Class I Insulation (24 Vac)
Ingress Protection Rating	IP54
Electrical Connections	Screw terminals
Frequency	60 Hz
Manual operation	Knob
Mounting	Directly on V5011/V5013 Globe Valves and VGF Flanged Globe Valves
Stroke	3/4 in. (20 mm); or 1 1/2 in (38 mm)
Materials	ABS Plastic
Operating Humidity Range (% RH)	5 to 95% RH
Medium Temperature	300 F Maximum (150 C Maximum)
Ambient Temperature Range	14 F to 122 F (-10 C to +50 C)
Storage Temperature Range	-40 F to 158 F (-40 C to 70 C)
Weight	5.1 lb (2.3 kg)
Includes	1/2 in. conduit hub

APPROVALS

Canadian Standards Association	Certified
CE	Recognized
Underwriters Laboratories, Inc.	UL94-5V

ACCESSORIES

- 43191679-101—Auxiliary Potentiometer for ML6421A
- 43191679-102—Auxiliary Potentiometer for ML6421B
- 43191680-102—Dual Auxiliary Switch for CREVAL actuators
- 43196000-001—High Temperature Kit for actuators with 3/4 in. stroke
- 43196000-038—High Temperature Kit for actuators with 1-1/2 in. stroke

DIMENSIONS DIAGRAM

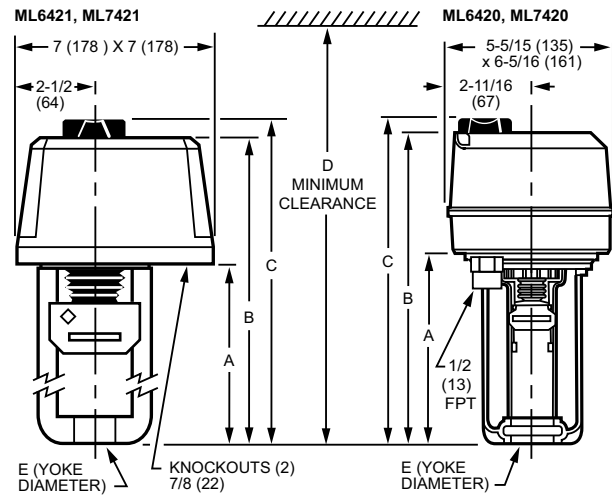

	ML6421A, ML7421A	ML6421B, ML7421B	ML6420, ML7420
A	5-5/8 (142)	8 (204)	5-9/16 (141)
B	9-3/8 (239)	11-7/8 (301)	9-3/16 (233)
C	10-3/8 (264)	12-3/4 (326)	9-9/16 (242)
D	14-1/4 (360)	16-7/8 (430)	12-11/16 (322)
E	1-3/8 (35)	1-7/8 (48)	1-3/8 (35)

M17463

Direct Coupled Valve Actuator

ML6425; ML7425



Direct Coupled Globe Valve Actuators provide floating and modulating control of chilled water, hot water, and steam, and mount directly on VGF series, V5011, and V5013 globe valves. These Spring Return Actuators will operate 1/2 to 3 in. valves.

FEATURES

- Easy and quick installation on valves with 1 3/8 in. bonnet and 3/4 in. stroke.
- No separate linkage required.
- Conduit connector standard.
- No adjustments required on linkage.
- Accurate valve positioning.
- Low power consumption.
- High close-off ratings.
- Force limiting end switches.
- Internal manual operator.
- Synchronous motor.
- Maintenance free.

SPECIFICATIONS

Actuator Type	Valve
Control Signal	Floating; 0-10 Vdc or 2-10 Vdc modulating
Fail Safe Mode	Stem down on power failure; or stem up on power failure
(Rated) Stem Force	135 lbf (600 N)
Spring Return Torque	135 lbf (600 N)
Cable Entry	Conduit connector and one knockout on actuator case
Electrical Protection	Class I Insulation (24 Vac)
Ingress Protection Rating	IP54
Electrical Connections	Screw terminals
Frequency	60 Hz
Manual operation	Manual override winding
Mounting	Directly on V5011/V5013 Globe Valves and VGF Flanged Globe Valves (3/4 in. or 20mm stroke)
Stroke	3/4 in. (20 mm)
Materials	ABS-FR Plastic, aluminum yoke
Operating Humidity Range (% RH)	5 to 95% RH
Medium Temperature	300 F Maximum (150 C Maximum)
Ambient Temperature Range	14 F to 122 F (-10 C to 50 C)
Storage Temperature Range	-40 F to 158 F (-40 C to 70 C)
Weight	5.1 lb (2.3 kg)
Includes	1/2 in. conduit hub

APPROVALS

CE	Recognized
Underwriters Laboratories, Inc.	UL94-5V

ACCESSORIES

- 43191679-111—Potentiometer, 10 K ohm, for ML6425, ML7425
- 43191679-112—Potentiometer, 220 ohm for ML6425, ML7425
- 43191680-105—Dual Auxiliary Switch for CREVAL actuators
- 43196000-001—High Temperature Kit for actuators with 3/4 in. stroke

DIMENSIONS DIAGRAM

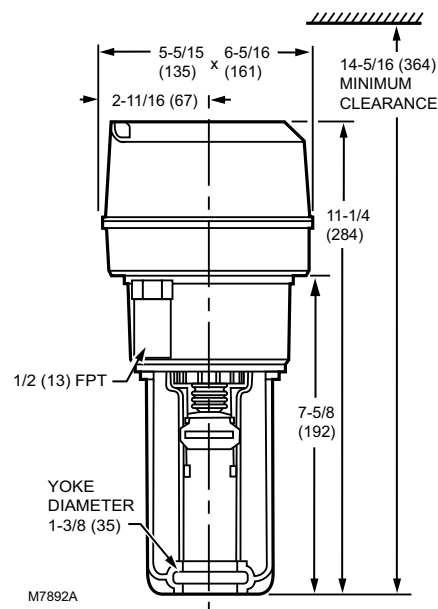

Direct Coupled Valve Actuator

ML6984



The ML6984 is a self-contained, self-adjusting, motorized linkage that mounts directly onto V5011 two-way or V5013 three-way valves and provides up to 25 mm (1 in.) of linear travel (stem lift). For use with low voltage 3-wire SPDT Series 20 (on-off); Series 60 (floating) electromechanical (dry contacts); or electronic (triac output) controllers.

SPECIFICATIONS

Actuator Type	Valve
Control Signal	Floating
Fail Safe Mode	Stays in place
(Rated) Stem Force	160 lbf (710 N)
Cable Entry	7/8 in. hole for 1/2 in. conduit
External Auxiliary Switches Available ..	272630D
Electrical Protection	NEMA 3R
Ingress Protection Rating	NEMA 3R, IP54 (mounted in vertical position)
Electrical Connections	Screw terminals
Feedback	Position feedback available w/ 272630D; 2-10 Vdc
Frequency	50 Hz, 60 Hz
Manual operation	None
Mounting	Screws onto 1/4-28 UNF threaded valve stem
Stroke	1/2 to 1 in. (13 to 25 mm)
Supply Voltage	24 Vac; 28 Vdc
Materials	UV-stabilized plastic cover, aluminum base & yoke
Operating Humidity Range (% RH)	15 to 95% RH at 104 F (40 C)
Medium Temperature	300 F Maximum (150 C Maximum)
Ambient Temperature Range	32 F to 130 F (0 C to 50 C)
Temperature Ratings (Shipping)	-40 F to 150 F (-40 C to 65 C)
Storage Temperature Range	-40 F to 150 F (-40 C to 65 C)
Weight	2.2 lb (1 kg)
Includes	Screw terminals
Comments	3 or 5-wire operation.

ACCESSORIES

- 272630D—position feedback and SPDT pilot duty auxiliary switch (5 wire mode only)
- 272629A—travel stop for VGF21ES/LS and VGF22ES/LS valves

FEATURES

- Allows the use of one common transformer power supply for multiple actuators and controllers.
- Self-contained, motorized valve linkage.
- Linkage self-adjusts to valve stroke of 1/2 to 1 in. (12 to 25 mm).
- Multi-pose mounting.
- Strong valve seat closing force 160 lb-in. (710 Newton).
- Compact size for easy installation in confined area.
- One device for either 24 Vac or 28 Vdc power supply application.
- Electronic current sensing provides internal protection and positive full closing force.
- Field-addable position feedback/auxiliary switch module available.
- Compatible with 3-wire control systems such as Excel 10.

DIMENSIONS DIAGRAM

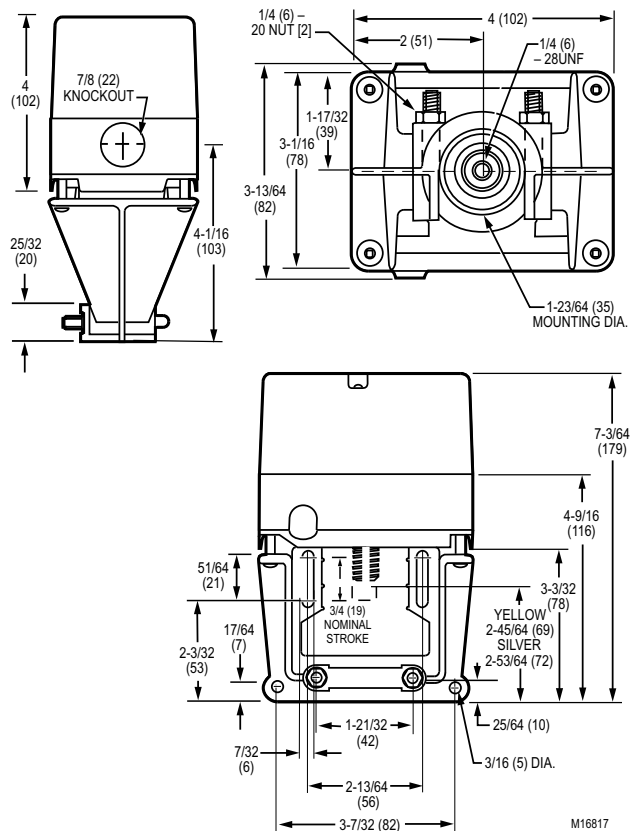

Direct Coupled Valve Actuator

ML7984



The ML7984 is a self-contained, self-adjusting, motorized linkage that mounts directly onto V5011 two-way or V5013 three-way valves and provides up to 25 mm (1 in.) of linear stem travel. For use with Series 70 2-10Vdc, 4-20mA; Series 90 135 ohm; and Electronic (Super Mod) modulating signals controllers.

SPECIFICATIONS

Actuator Type	Valve
Control Signal	2-10 Vdc, 4-20 mA, 135 ohm slidewire or SuperMod signal.
Fail Safe Mode	Stays in place
(Rated) Stem Force	160 lbf (710 N)
Cable Entry	7/8 in. hole for 1/2 in. conduit
External Auxiliary Switches Available ..	272630D
Electrical Protection	NEMA 3R
Ingress Protection Rating	NEMA 3R, IP54 (mounted in vertical position)
Electrical Connections	Screw terminals
Feedback	Position feedback available w/ 272630D; 2-10 Vdc
Frequency	50 Hz; 60 Hz
Manual operation	None
Mounting	Screws onto 1/4-28 UNF threaded valve stem
Stroke	1/2 to 1 in. (13 to 25 mm)
Supply Voltage	24 Vac; 28 Vdc
Materials	UV-stabilized plastic cover, aluminum base & yoke
Operating Humidity Range (% RH)	15 to 95% RH at 104 F (40 C)
Ambient Temperature Range	32 F to 130 F (0 C to 55 C)
Temperature Ratings (Shipping)	-40 F to 150 F (-40 C to 65 C)
Storage Temperature Range	-40 F to 150 F (-40 C to 65 C)
Weight	2.2 lb (1 kg)
Includes	Screw terminals
Comments	Direct/Reverse Acting Switch

ACCESSORIES

272630D—position feedback and SPDT pilot duty auxiliary switch
 272629A—travel stop for VGF21ES/LS and VGF22ES/LS valves

FEATURES

- Allows the use of one common transformer power supply for multiple actuators and controllers.
- Self-contained, motorized valve linkage.
- Linkage self-adjusts to valve stroke from 1/2 to 1 in. (12 to 25 mm).
- Multi-pose mounting.
- Strong valve seat closing force 710 Newton (160 lb.).
- Compact size for easy installation in confined area.
- One device for either Vac or Vdc power supply application.
- Electronic current sensing provides internal protection and positive full closing force.
- Field-addable position feedback/auxiliary switch module available.

DIMENSIONS DIAGRAM

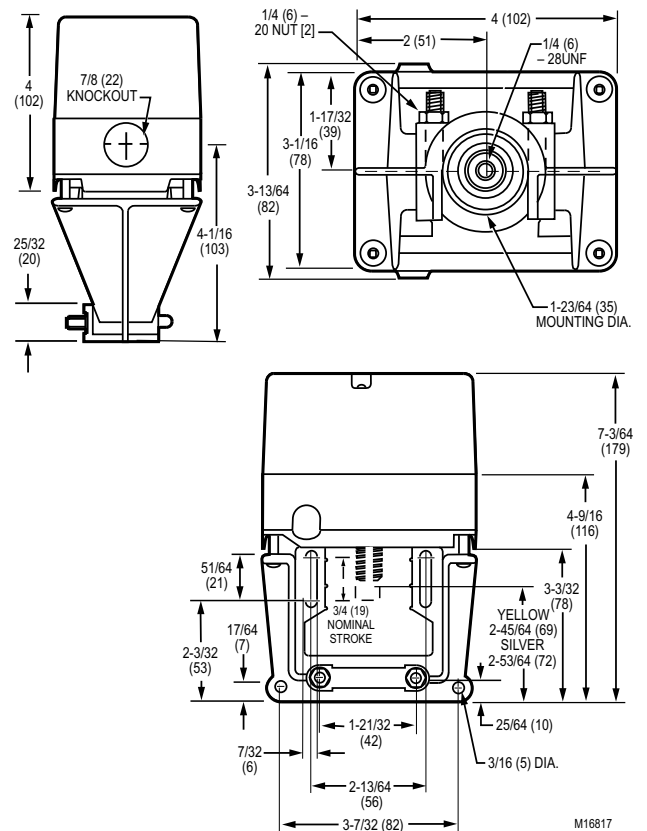

SUBMITTAL SHEETS

Unitary Valve

VU52; VU53



Two-way Fan Coil Valves, the VU53 high pressure zone valves are used to control the flow of hot or chilled water in commercial HVAC equipment such as fan coil units, terminal reheat coils and convectors.

IMPORTANT: These valves are not for use in systems containing dissolved oxygen.

FEATURES

- Compact construction for easy installation.
- Fits under the cover of most baseboard convectors with actuator fitted to valve body.
- VU52 and VU53 provide 2-way, straight-through control of water.
- Available in normally closed (VU53) or normally open (VU52) configurations.
- 300 psi (2,000 kPa, PN20) operating pressure rating.
- Patented ball seal provides long service life, soft close off.
- Triple O-ring seal provides three lines of defense against corrosion and water leakage around drive shaft.
- Quick opening flow curve.
- Available with NPT end connections for iron or steel piping.

SPECIFICATIONS

Valve Type	Fan Coil Valve
Valve Size	1/2; 3/4; or 1 in.
Connection Type	Sweat; NPT; or 1/2 in. Inverted flare
Body Pattern	Two-way, Straight-through
Flow Characteristic	Quick Opening
Controlled Medium	Hot/Chilled Water with up to 60% Glycol
Maximum Safe Operating Pressure	300 psig (2068 kPa)
Ambient Temperature Range	34 F to 125 F at 200 F Fluid (1 to 52 C @ 94 C Fluid)
Actuation	Must be purchased separately
Materials	
(Body)	Brass
(Stem)	Brass
(Seat)	Brass
(Plug/Ball/Disc)	Buna-N rubber
(Packing)	EPDM rubber

APPROVALS

Canadian Standards Association CSA C/US

DIMENSIONS DIAGRAM

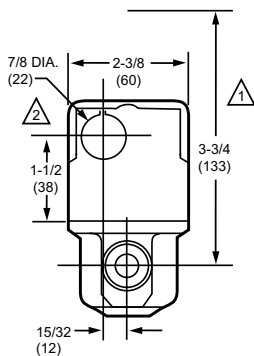

VU52 AND VU53 VALVE WITH VU448 ACTUATOR

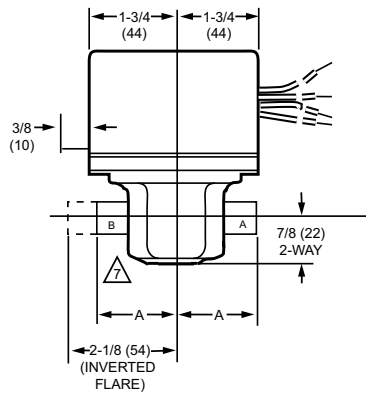

VU52 AND VU53 VALVE WITH ACTUATOR

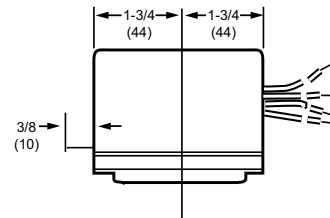

VU ACTUATOR

- ▲1 HEIGHT NEEDED TO REMOVE ACTUATOR OR COVER
- ▲2 OPENING FOR 1/2 IN. CONDUIT ON OPPOSITE SITE OF MANUAL LEVER FOR ALL MODELS.

VALVE BODY SIZE	A
1/2 IN. SWEAT	1-5/6 (33)
3/4 IN. SWEAT	1-3/8 (35)
1 IN. SWEAT	1-11/16 (43)
1/2 IN. NPT	1-3/8 (35)
3/4 IN. NPT	1-11/16 (43)

M16818



Three-way Fan Coil Valve, the VU54 high pressure zone valves are used to control the flow of hot or chilled water in commercial HVAC equipment such as fan coil units, terminal reheat coils and convectors.

IMPORTANT: These valves are not for use in systems containing dissolved oxygen.

FEATURES

- Compact construction for easy installation.
- Fits under the cover of most baseboard convectors with actuator fitted to valve body.
- VU54 provides three-way diverting control of water.
- 300 psi (2,000 kPa, PN20) operating pressure rating.
- Patented ball seal provides long service life, soft close off.
- Triple O-ring seal provides three lines of defense against corrosion and water leakage around drive shaft.
- Quick opening flow curve.
- Choice of NPT end connections for iron or steel piping.

SPECIFICATIONS

Valve Type	Fan Coil Valve
Valve Size	1/2; 3/4; or 1 in.
Connection Type	Sweat; NPT; or 1/2 in. Inverted flare
Body Pattern	Three-way A-AB-B
Flow Characteristic	Quick Opening
Controlled Medium	Hot Water; Chilled Water with up to 60% Glycol
Maximum Safe Operating Pressure	300 psig (2068 kPa)
Ambient Temperature Range	34 F to 125 F at 200 F Fluid (1 to 52 C @ 94 C Fluid)
Actuation	Must be purchased separately
Materials	
(Body)	Brass
(Stem)	Brass
(Seat)	Brass
(Plug/Ball/Disc)	Buna-N rubber
(Packing)	EPDM rubber

APPROVALS

Canadian Standards Association CSA C/US

DIMENSIONS DIAGRAM

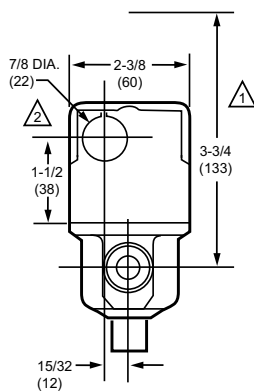

VU54 VALVE WITH VU448 ACTUATOR

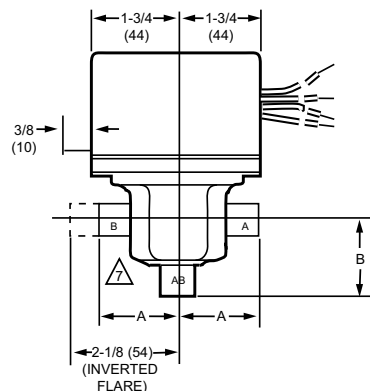

VU54 VALVE WITH ACTUATOR

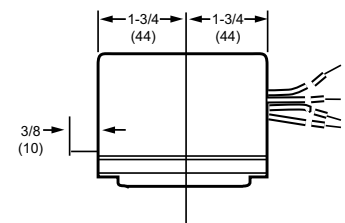

VU ACTUATOR

- ⚠ HEIGHT NEEDED TO REMOVE ACTUATOR OR COVER
- ⚠ OPENING FOR 1/2 IN. CONDUIT ON OPPOSITE SITE OF MANUAL LEVER FOR ALL MODELS.

VALVE BODY SIZE	A	B
1/2 IN. SWEAT	1-5/6 (33)	1-5/6 (33)
3/4 IN. SWEAT	1-3/8 (35)	1-11/16 (43)
1 IN. SWEAT	1-11/16 (43)	1-11/16 (43)
1/2 IN. NPT	1-3/8 (35)	1-5/16 (33)
3/4 IN. NPT	1-11/16 (43)	1-7/16 (37)

M16819

Unitary Valve

VCZA; VCZB



Two-way Cartridge Cage Valves are intended for hydronic applications in a normal indoor environment to control the flow of hot water or chilled water glycol solution to 60% concentration. These valves are designed for zone control of heating/cooling systems, or to control individual fan coil, baseboard radiator or convector applications. Depending on the model selected they can be controlled by SPST or SPDT two

position controller, tristate (floating), or modulating proportional controller. For trouble-free operation of the product, good installation practice must include initial system flushing, chemical water treatment, and the use of a 50 micron (or finer) system side stream filter(s). Remove all filters before flushing.

FEATURES

- Quick open, linear, and equal percentage flow characteristics available.
- Bi-directional installation.
- 3000-series valves for floating and modulating non-fail safe applications
- 1000-series valves for two-position control
- High close-off rating independent of C_v .
- Available with a variety of North American and international pipe fittings.
- No tools required for actuator installation or removal.
- Actuator removal does not require draining system.
- Service is by replacement of cartridge, not valve body.
- Cartridge replacement rebuilds valve to factory-new condition.

SPECIFICATIONS

Valve Type	Cartridge Cage Valve
Body Pattern	Two-way, Straight-through
Connection Type	Sweat or , Female NPT
Controlled Medium	Hot/Chilled Water with up to 60% Glycol
Flow characteristic	Quick open, linear, or equal percentage
Maximum Safe Operating Pressure	300 psi (2068 kPa (20 Bar))
Close-off pressure	60 psid (414 kPa [4.1 bar])
Fluid Temperature Range	34 F to 203 F (1 C to 95 C)
Ambient Temperature Range	32 F to 150 F (0 C to 65 C)
Stem Travel	0.4 in. (10 mm)
Materials	
(Body)	Bronze
(Stem)	Stainless Steel
(Seat)	EPDM O-ring seals on Noryl piston
(Cartridge)	Ryton™, Noryl™ engineering plastic
(Packing)	EPDM rubber

APPROVALS

Canadian Standards Association CSA Certified

ACCESSORIES

40007029-002—Wrench for cartridge (included with sweat valves and all replacement cartridges)



Three-way Cartridge Cage Valves are intended for hydronic applications in a normal indoor environment to control the flow of hot water or chilled water glycol solution to 60% concentration. These valves are designed for zone control of heating/cooling systems, or to control individual fan coil, baseboard radiator or convector applications. Depending on the model selected they can be controlled by SPST or SPDT two

position controller, tristate (floating), or modulating proportional controller. For trouble-free operation of the product, good installation practice must include initial system flushing, chemical water treatment, and the use of a 50 micron (or finer) system side stream filter(s). Remove all filters before flushing.

FEATURES

- Quick open and linear flow characteristics available.
- Mixing or diverting application.
- A-AB-B body pattern.
- 7000-series valves for floating and modulating non-fail safe applications
- 6000-series valves for two-position control
- High close-off rating independent of C_v .
- Available with a variety of North American and international pipe fittings.
- No tools required for actuator installation or removal.
- Actuator removal does not require draining system.
- Service is by replacement of cartridge, not valve body.
- Cartridge replacement rebuilds valve to factory-new condition.

SPECIFICATIONS

Valve Type	Cartridge Cage Valve
Body Pattern	Three-way A-AB-B
Connection Type	Sweat, , Female NPT
Controlled Medium	Hot/Chilled Water with up to 60% Glycol
Flow characteristic	Quick open or linear
Maximum Safe Operating Pressure	300 psi (2068 kPa (20 Bar))
Close-off pressure	60 psid (414 kPa [4.1 bar])
Fluid Temperature Range	34 F to 203 F (1 C to 95 C)
Ambient Temperature Range	32 F to 150 F (0 C to 65 C)
Stem Travel	0.4 in. (10 mm)
Materials	
(Body)	Bronze
(Stem)	Stainless Steel
(Seat)	EPDM O-ring seals on Noryl piston
(Cartridge)	Ryton™, Noryl™ engineering plastic
(Packing)	EPDM rubber

APPROVALS

Canadian Standards Association CSA Certified

ACCESSORIES

40007029-002—Wrench for cartridge (included with sweat valves and all replacement cartridges)

Unitary Valve

V5852; V5862



Two-way Cartridge Globe Valves control hot and/or chilled water for VAV terminal units, fan coil units, small reheaters and recoolers in electric/electronic temperature control systems. Used with the M6410 3-position floating Non-Spring Return Valve Actuator and the M7410 selectable 0 to 10 Vdc or 2 to 10 Vdc Non-Spring Return Actuator. The 1/2 and 3/4 in. valves are compatible with the M6435

floating Spring Return Actuator, the M7435 selectable 0 to 10 Vdc or 2 to 10 Vdc Spring Return Actuator, and the MP958 Pneumatic Actuator. Larger valves (1 in. through 1-1/2 in.) are pressure balanced, which results in higher close-off pressures.

SPECIFICATIONS

Valve Type	Cartridge Globe Valve
Body Pattern	Two-way
Flow characteristic	Equal percentage for 1/2 and 3/4 in. Linear for 1 to 1 1/2 in.
Connection Type	Sweat , Female NPT
Controlled Medium	Hot/Chilled Water with up to 50% Glycol
Leakage Rating	less than 0.02% of C_v
Maximum Safe Operating Pressure	235 psi (1620 kPa)
Ambient Temperature Range	36 F to 230 F (2 C to 110 C)
Stem Travel	1/4 in. (6.4 mm)
Materials	
(Body)	Brass
(Stem)	Stainless Steel
(Seat)	Brass
(Cartridge)	Brass
(Plug/Ball/Disc)	Brass
Includes	combination dust cap/manual operator

FEATURES

- Long stroke allows wider range of control.
- Soft valve seat provides low leakage rate.
- Inserts for 1/2 in. and 3/4 in. valves are changeable without draining valve when used with an insert replacement tool.
- Brass body and Stainless Steel stem.
- Threaded plastic cover/manual handle allows manual operation.
- Easily installed in areas where space is limited.

DIMENSIONS DIAGRAM

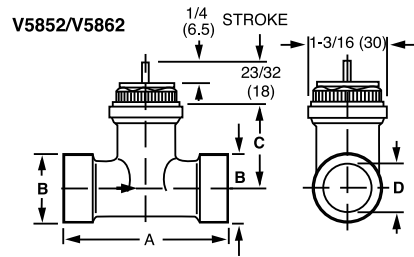

VALVE SIZE	A	B	C	D (NPT)	D (SWEAT)
1/2 (13)	3 (77)	3/4 (19)	1-5/16 (34)	1/2 (13)	5/8 (16)
3/4 (19)	3-1/2 (88)	1 (25)	1-1/4 (32)	3/4 (19)	7/8 (22)

NOTE: SOLDER ENDS CONFORM TO ANSI B16-18.

M18917

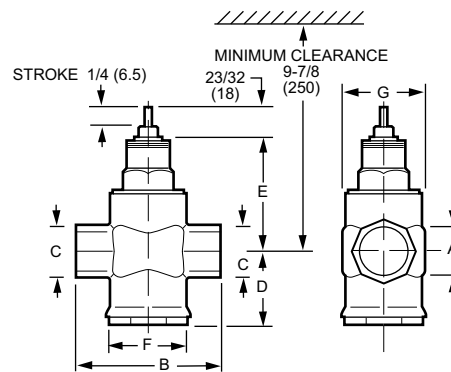

VALVE SIZE A (NPT)	B	C	D	E	F	G
1 (25)	4-1/8 (105)	1-5/8 (41)	2-1/16 (53)	3-5/8 (92)	2 (50)	1-3/4 (44)
1-1/4 (32)	4-15/16 (125)	2 (50)	2-7/16 (62)	3-5/8 (92)	2-3/16 (55)	2-1/4 (57)
1-1/2 (38)	5-1/8 (130)	2-3/16 (55)	2-9/16 (65)	3-7/8 (98)	2-3/8 (60)	2-5/8 (67)



Three-way Cartridge Globe Valves control hot and/or chilled water for VAV terminal units, fan coil units, small reheaters and recoolers in electric/ electronic temperature control systems. Used with the M6410 3-position floating Non-Spring Return Valve Actuator and the M7410 selectable 0 to 10 Vdc or 2 to 10 Vdc Non-Spring Return Actuator. The 1/2 in. and 3/4 in. valves are also compatible with the M6435 floating Spring Return

Actuator, the M7435 selectable 0 to 10 Vdc or 2 to 10 Vdc Spring Return Actuator, and the MP958 Pneumatic Actuator.

SPECIFICATIONS

Valve Type	Cartridge Globe Valve
Body Pattern	Three-way
Flow Characteristic	A -port - Equal percentage for 1/2 and 3/4 in. Linear for 1 to 1 1/2 in. B-port - Linear @ 20% reduced Cv
Connection Type	Sweat , Female NPT
Controlled Medium	Hot/Chilled Water with up to 50% Glycol
Leakage Rating	less than 0.02% of C _v
Maximum Safe Operating Pressure	235 psi (1620 kPa)
Ambient Temperature Range	36 F to 230 F (2 C to 110 C)
Stem Travel	1/4 in. (6.4 mm)
Materials	
(Body)	Brass
(Stem)	Stainless Steel
(Seat)	Brass
(Cartridge)	Brass
(Plug/Ball/Disc)	Brass
Includes	Combination manual opener/ dust cap

FEATURES

- Long stroke allows wider range of control.
- Soft valve seat provides low leakage rate.
- Inserts for 1/2 in. and 3/4 in. valves are changeable without draining valve when used with an insert replacement tool.
- Brass body and stainless steel stem.
- Threaded plastic cover/manual handle allows manual operation.
- Easily installed in areas where space is limited.

DIMENSIONS DIAGRAM

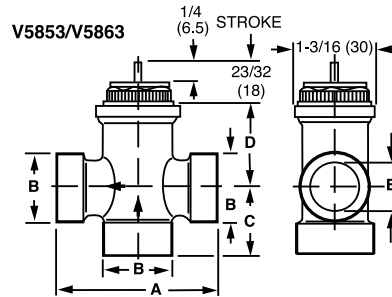

VALVE SIZE	A	B	C	D	E (NPT)	E (SWEAT)
1/2 (13)	3 (77)	3/4 (19)	1-5/16 (34)	1-5/16 (34)	1/2 (13)	5/8 (16)
3/4 (19)	3-1/2 (88)	1 (25)	1-1/2 (38)	1-1/4 (32)	3/4 (19)	7/8 (22)

NOTE: SOLDER ENDS CONFORM TO ANSI B16-18.

M18919

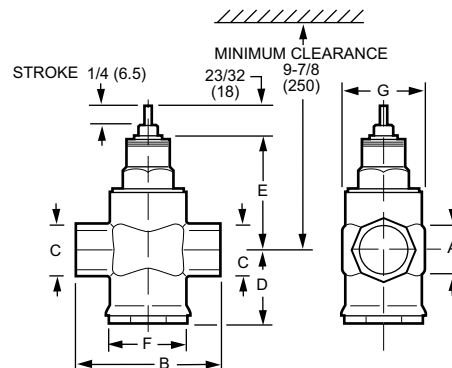

VALVE SIZE A (NPT)	B	C	D	E	F	G
1 (25)	4-1/8 (105)	1-5/8 (41)	2-1/16 (53)	3-5/8 (92)	2 (50)	1-3/4 (44)
1-1/4 (32)	4-15/16 (125)	2 (50)	2-7/16 (62)	3-5/8 (92)	2-3/16 (55)	2-1/4 (57)
1-1/2 (38)	5-1/8 (130)	2-3/16 (55)	2-9/16 (65)	3-7/8 (98)	2-3/8 (60)	2-5/8 (67)

Control Ball Valve

VBN2



The VBN2 Two-Way Control Ball Valves control hot and chilled water with glycol solutions up to 50% in heating, ventilating, and air conditioning (HVAC) systems to provide two-position or modulating functions. These valve assemblies can be ordered with or without factory-mounted non-spring return or spring return direct-coupled actuators (DCA).

FEATURES

- Sizes from 1/2 to 2-1/2 in. with internal (female) NPT connections.
- Equal percentage or linear flow characteristics.
- Choice of four, factory-installed actuation control schemes: Floating, Modulating (2-10 V), Spring Return 2-Position, Spring Return Modulating/Floating.
- Field configurable for normally open or normally closed fail-safe position.
- Removable manual operating handle to control valve during installation or in an event of power failure.
- ANSI Class IV seat leakage specification (0.01% of C_v).
- Optional NEMA 3R (IP54) rated enclosure for outdoor applications.
- Actuator can be mounted on the valve in any of four positions.
- Sizes up to 3 in.
- Wide C_v choices from 0.38 to 266.
- Nickel-chrome plated brass or 316 stainless steel valve ball and stem.

SPECIFICATIONS

Valve Type	Control Ball Valve
Body Pattern	Two-way
Flow Characteristic	Equal percentage with patented control insert.
Connection Type	NPT Female
Controlled Medium	Hot/Chilled Water with up to 50% Glycol
Leakage Rating	ANSI Class IV
Maximum Safe Operating Pressure	360 psi (2482 kPa)
Fluid Temperature Range	-22 F to 250 F (-30 C to 121 C)
Materials	
(Body)	Brass
(Stem)	Brass
(Seat)	Teflon® seals with EPDM O-rings
(Plug/Ball/Disc)	Nickel-plated brass ball; or stainless steel
(Flow optimizer)	Noryl(C)

DIMENSIONS DIAGRAM

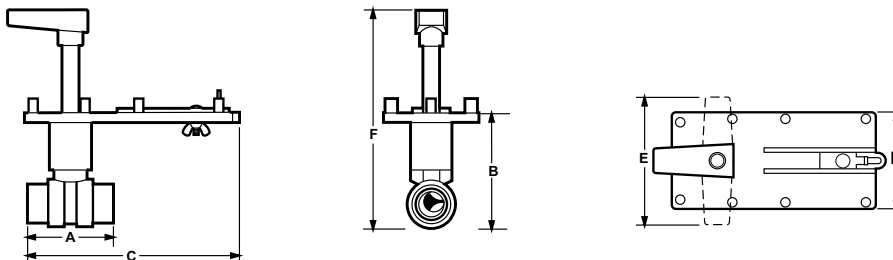

Pipe Size	Model No.	C_v	Dimensions inches (mm)						Weight lb (kg)
			A	B	C	D	E	F	
1/2"	VBN2A	0.38, 0.68, 1.3, 2.0, 2.6, 4.7, 11.7	2-3/8 (60)	3-7/16 (87)	6-5/8 (168)	3 (76)	4 (102)	8-1/8 (206)	1 (0.5)
		8.0	2-5/8 (67)	3-11/16 (94)	6-1/2 (165)	3 (76)	4 (102)	8-5/16 (211)	1 (0.5)
3/4"	VBN2B	0.31, 0.63, 1.2, 2.5, 4.3, 7.4, 14.7	2-3/8 (60)	3-7/16 (87)	6-7/16 (164)	3 (76)	4 (102)	8-1/8 (206)	1 (0.5)
		10.1, 29	2-5/8 (67)	3-11/16 (94)	6-1/2 (165)	3 (76)	4 (102)	8-5/16 (211)	1 (0.5)
1"	VBN2C	9.0	3-3/4 (95)	3-11/16 (94)	7-1/16 (179)	3 (76)	4 (102)	8-5/16 (211)	1 (0.5)
		4.4, 15.3, 54	3 (76)	3-15/16 (100)	6-3/4 (171)	3 (76)	4 (102)	8-11/16 (221)	1.4 (0.6)
		26, 44	4-3/8 (111)	4-7/16 (113)	7-3/8 (187)	3 (76)	4 (102)	8-7/8 (225)	2.4 (1.1)
1-1/4"	VBN2D	4.4, 8.3, 14.9, 25, 41	3 (76)	3-15/16 (100)	6-11/16 (170)	3 (76)	4 (102)	8-11/16 (221)	1.4 (0.6)
		37, 102	3-5/8 (92)	4-7/16 (113)	7 (178)	3 (76)	4 (102)	9-1/16 (231)	2.4 (1.1)
1-1/2"	VBN2E	23, 30, 74	3-3/8 (86)	3-15/16 (100)	6-15/16 (176)	3 (76)	4 (102)	9-1/16 (231)	2.4 (1.1)
		41, 172	3-3/4 (95)	5-3/16 (132)	7-1/16 (179)	3 (76)	4 (102)	8-7/8 (225)	3.2 (1.5)
2"	VBN2F	42, 108	4 (102)	5-3/16 (132)	7-3/16 (183)	3 (76)	4 (102)	8-7/8 (225)	3.2 (1.5)
		57, 71, 100, 210, 266	4-3/8 (111)	5-3/4 (146)	7-7/16 (189)	3 (76)	4 (102)	10-1/2 (267)	5 (2.3)
2-1/2"	VBN2G	45, 55, 72, 101, 162, 202	4-3/4 (121)	5-3/4 (146)	7-9/16 (192)	3 (76)	4 (102)	10-1/2 (267)	5.5 (2.5)
3"	VBN2H	49, 63, 82, 124, 145	5 (127)	5-7/8 (149)	7-11/16 (195)	3 (76)	4 (102)	10-11/16 (271)	5.9 (2.7)

M13729



The VBN3 Three-Way Control Ball Valves control hot and chilled water with glycol solutions up to 50% in heating, ventilating, and air conditioning (HVAC) systems to provide two-position or modulating functions. These valve assemblies can be ordered with or without factory-mounted non-spring return or spring return direct-coupled actuators (DCA).

FEATURES

- Sizes from 1/2 to 2-1/2 in. with internal (female) NPT connections.
- Equal percentage or linear flow characteristics.
- Choice of four, factory-installed actuation control schemes: Floating, Modulating (2-10 V), Spring Return 2-Position, Spring Return Modulating/Floating.
- Field configurable for normally open or normally closed fail-safe position.
- Removable manual operating handle to control valve during installation or in an event of power failure.
- ANSI Class IV seat leakage specification (0.01% of C_v).
- Optional NEMA 3R (IP54) rated enclosure for outdoor applications.
- Actuator can be mounted on the valve in any of four positions.
- Wide C_v choices from 0.33 to 109.
- Valve installs in a globe valve "T" pattern, no extra elbows or piping required.
- Nickel-chrome plated brass valve ball and stem.
- Mixing or Diverting control.

SPECIFICATIONS

Valve Type	Control Ball Valve
Body Pattern	Three-way
Flow Characteristic	Equal percentage with patented control insert.
Connection Type	NPT Female
Controlled Medium	Hot/Chilled Water with up to 50% Glycol
Leakage Rating	ANSI Class IV
Maximum Safe Operating Pressure	360 psi (2482 kPa)
Fluid Temperature Range	-22 F to 250 F (-30 C to 121 C)
Materials	
(Body)	Brass
(Stem)	Brass
(Seat)	Teflon® seals with EPDM O-rings
(Plug/Ball/Disc)	Nickel-plated brass ball

DIMENSIONS DIAGRAM

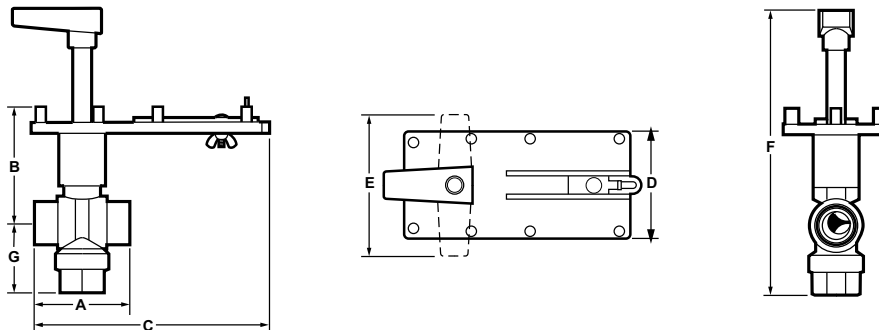

Pipe Size	Model No.	C_v	Dimensions inches (mm)						Weight lb (kg)	
			A	B	C	D	E	F		G
1/2"	VBN3A	0.33, 0.59, 1.0, 2.4, 4.3, 8.0	3-1/2 (90)	3-5/16 (84)	7 (178)	3 (76)	4 (102)	9-3/8 (238)	2-3/8 (60)	2.4 (1.1)
3/4"	VBN3B	0.40, 0.66, 1.3, 2.4, 3.8, 11.0	2-13/16 (71)	3-5/16 (84)	6-1/2 (168)	3 (76)	4 (102)	8-13/16 (224)	2 (51)	2 (0.9)
1"	VBN3C	0.40, 0.65, 1.3, 2.3, 3.5	3-13/16 (97)	3-5/16 (84)	7-5/16 (186)	3 (76)	4 (102)	9-1/2 (241)	2-3/4 (70)	2.8 (1.3)
		8.6, 22	3 (76)	3-13/16	6-13/16 (173)	3 (76)	4 (102)	9-13/16 (249)	2-5/8 (67)	2.6 (1.2)
1-1/4"	VBN3D	4.5, 14.9, 31	4-1/2 (114)	4 (102)	7-13/16 (198)	3 (76)	4 (102)	10-13/16 (275)	3-1/4 (83)	3.3 (1.5)
		4.1, 8.7, 19.0	3 (76)	3-13/16	6-13/16 (173)	3 (76)	4 (102)	9-13/16 (249)	2-1/2 (64)	2.5 (1.1)
1-1/2"	VBN3E	12.7, 27, 34	3-5/8 (92)	4 (102)	7-5/16 (186)	3 (76)	4 (102)	10-5/16 (262)	2-3/4 (70)	2.8 (1.3)
		4.0, 8.3, 13.4, 32	4-1/2 (114)	4 (102)	7-13/16 (198)	3 (76)	4 (102)	10-13/16 (275)	3-1/4 (83)	3.3 (1.5)
2"	VBN3F	24, 61	4 (102)	4-1/2 (114)	7-5/16 (186)	3 (76)	4 (102)	11 (279)	3-1/4 (83)	3.3 (1.5)
		24, 38, 57	4 (102)	4-1/2 (114)	7-5/16 (186)	3 (76)	4 (102)	11 (279)	3-1/4 (83)	3.3 (1.5)
2-1/2"	VBN3G	83, 109	5 (127)	5-13/16	7-13/16 (198)	3 (76)	4 (102)	12-5/16 (313)	3-3/4 (95)	3.8 (1.7)
		38, 74, 100	5 (127)	5-13/16	7-13/16 (198)	3 (76)	4 (102)	12-5/16 (313)	3-3/4 (95)	3.8 (1.7)

M13730

Control Ball Valve

VBF2



The VBF2 Two-Way Ball Valve Assemblies, with and without actuators, control hot and chilled water with glycol solutions up to 50% in heating, ventilating, and air conditioning (HVAC) systems to provide two-position or modulating functions. These valve assemblies can be ordered with or without factory-mounted non-spring return or spring return direct-coupled actuators (DCA).

SPECIFICATIONS

Valve Type	Control Ball Valve
Body Pattern	Two-way
Flow Characteristic	Equal percentage with laser-milled port.
Connection Type	ANSI 125/PN16 Flange
Controlled Medium	Hot/Chilled Water with up to 50% Glycol
Leakage Rating	ANSI Class IV
Maximum Safe Operating Pressure	240 psi (1655 kPa)
Fluid Temperature Range	-22 F to 250 F (-30 C to 121 C)
Materials	
(Body)	Cast Iron
(Stem)	316 stainless steel
(Seat)	Teflon®
(Plug/Ball/Disc)	316 stainless steel

FEATURES

- Sizes from 4 to 6 in. with ANSI Class 125 flanged connections.
- Equal percentage flow characteristics.
- Choice of four, factory-installed actuation control schemes: Floating, Modulating (2-10 V), Spring Return 24V 2-Position, Spring Return Modulating/Floating.
- Field configurable for normally open or normally closed fail-safe position.
- Removable manual operating handle to control valve during installation or in an event of power failure.
- ANSI Class IV leakage specification (0.01% of C_v).
- Optional NEMA 3R (IP54) rated enclosure for outdoor applications.
- Option of four actuator mounting positions on the valve.
- Wide range of C_v choices from 91 to 650.
- Valve ball and stem 316 stainless steel.

DIMENSIONS DIAGRAM

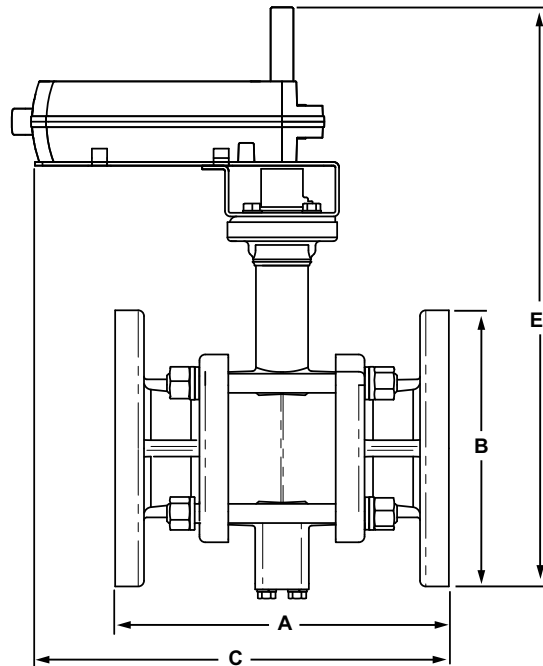

Size (in.)	Model Number	A in. (mm)	B in. (mm)	C in. (mm)	D (depth) (not shown) in. (mm)	E in. (mm)	Wt. lb (kg)
4	VBF2J	11 (278)	9 (229)	13-1/4 (337)	9 (229)	18-3/4 (476)	65 (31)
5	VBF2K	12-3/8 (352)	10 (254)	14-1/4 (362)	10 (254)	19 (483)	75 (34)
6	VBF2L	13-7/8 (352)	11 (278)	15-1/8 (384)	11 (278)	19-7/8 (505)	90 (41)

M13732



The VBF3 Three-Way Ball Valve Assemblies, with and without actuators, control hot and chilled water with glycol solutions up to 50% in heating, ventilating, and air conditioning (HVAC) systems to provide two-position or modulating functions. These valve assemblies can be ordered with or without factory-mounted non-spring return or spring return direct-coupled actuators (DCA).

SPECIFICATIONS

Valve Type	Control Ball Valve
Body Pattern	Three-way
Flow Characteristic	Equal percentage with laser-milled port. (A-AB); Linear (B-AB)
Connection Type	ANSI 125/PN16 Flange
Controlled Medium	Hot/Chilled Water with up to 50% Glycol
Leakage Rating	ANSI Class IV (A port only)
Maximum Safe Operating Pressure	240 psi (1655 kPa)
Fluid Temperature Range	-22 F to 250 F (-30 C to 121 C)
Materials	
(Body)	Cast Iron
(Stem)	316 stainless steel
(Seat)	Teflon®
(Plug/Ball/Disc)	316 stainless steel

FEATURES

- Sizes from 4 to 6 in. with ANSI Class 125 flanged connections.
- Equal percentage or linear flow characteristics.
- Choice of four, factory-installed actuation control schemes: Floating, Modulating (2-10 V), Spring Return 24V 2-Position, Spring Return Modulating/Floating.
- Field configurable for normally open or normally closed fail-safe position.
- Removable manual operating handle to control valve during installation or in an event of power failure.
- ANSI Class IV A-port seat leakage (0.01% of C_v).
- Optional NEMA 3R (IP54) rated enclosure for outdoor applications.
- Option of four actuator mounting positions on the valve.
- Wide range of C_v choices from 91 to 650.
- Valve ball and stem 316 stainless steel.
- Mixing or Diverting control.

DIMENSIONS DIAGRAM

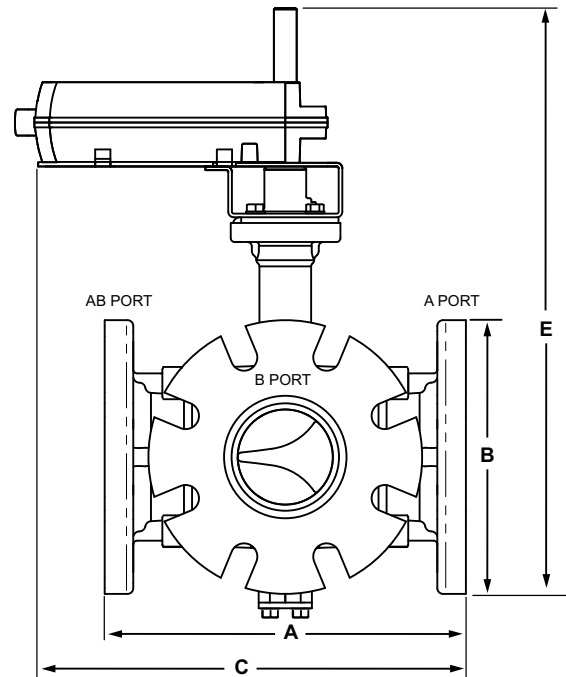

Size (in.)	Model Number	A in. (mm)	B in. (mm)	C in. (mm)	D (depth) (not shown) in. (mm)	E in. (mm)	Wt. lb (kg)
4	VBF3J	11-7/8 (278)	9 (229)	14-1/8 (337)	10-3/8 (229)	18-1/2 (470)	75 (34)
5	VBF3K	13-7/8 (352)	10 (254)	15-1/8 (362)	12 (254)	19-3/8 (483)	90 (41)
6	VBF3L	15-7/8 (403)	11 (278)	16-1/8 (410)	13-3/8 (521)	20-1/2 (521)	105 (48)

M13733A

NPT Globe Valve

V5011F,G



Used for two-position or modulating control of steam and water and glycol solutions (to 50 percent concentration) in heating or cooling systems.

FEATURES

- Sizes range from 2-1/2 to 3 in.
- Direct and reverse acting
- High pressure steam models with stainless steel trim
- Spring-loaded, self-adjusting packing.
- Stainless steel stem prevents corrosion.
- Valve designs provide equal percentage flow characteristics for close control of water, and linear flow characteristic for close control of steam.
- Valves utilize direct mounting valve actuators or Q5020/Q5022A linkages with Direct Coupled Actuators or Pneumatic Valve Actuators to operate the valve.

SPECIFICATIONS

Valve Type	Globe Valve
Body Pattern	Two-way
Valve Action	Stem down to close
Connection Type	NPT Female
Controlled Medium	Hot/Chilled Water with up to 50% Glycol
Flow characteristic	Equal percentage (water); Linear (steam)
Leakage Rating	0.5% of C_v
Maximum Safe Operating Pressure	250 psi at 100 F water (1724 kPa at 38 C water) 15 psi steam (100 kPa steam) 217 psi at 250 F water V5011G: 100 psi (690 kPa) steam
Maximum Differential for Quiet Water Service	20 psid (138 kPa)
Fluid Temperature Range	40 F to 337 F (4 C to 169 C)
Stem Travel	3/4 in. (20 mm)
Materials	
(Body)	Red Brass
(Stem)	Stainless Steel
(Seat)	Brass
(Plug/Ball/Disc)	Brass plug with Teflon® disc
(Packing)	Teflon and Nitrile

APPROVALS

CRN Number 0C0861.9087YTN

DIMENSIONS DIAGRAM

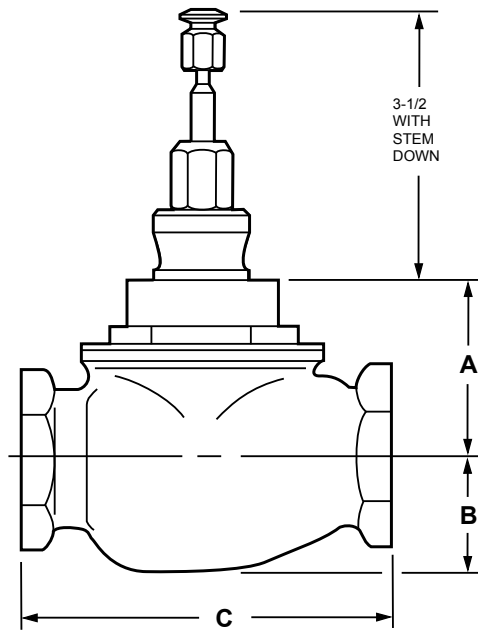

V5011F,G

BODY STYLE	PIPE SIZE (in.)	DIMENSIONS					
		A		B		C	
		in	mm	in	mm	in	mm
V5011F,G THREADED DIRECT BODY	1/2	2	51	1-3/4	45	3-3/8	86
	3/4	1-3/4	45	1-3/4	45	3-3/8	86
	1	1-7/8	48	1-3/4	45	4-1/4	108
	1-1/4	2	51	1-5/8	42	4-7/8	124
	1-1/2	2-7/8	73	1-5/8	42	5-5/8	143
	2	3-1/8	80	2	51	5-5/8	143
	2-1/2	2-3/4	70	2-3/8	61	7-1/2	191
	3	3-1/8	80	2-5/8	67	8-7/8	226

M2804A



Used for two-position or modulating control of steam and water and glycol solutions (to 50 percent concentration) in heating or cooling systems.

FEATURES

- Sizes range from 1/2 to 2 in.
- Direct and reverse acting
- High pressure steam models with stainless steel trim
- Spring-loaded, self-adjusting packing.
- Stainless steel stem prevents corrosion.
- Valve designs provide equal percentage flow characteristics for close control of water, and linear flow characteristic for close control of steam.
- Valves utilize direct mounting linear valve actuators, Q5020/Q5022A linkages with direct coupled rotary actuators, or pneumatic valve actuators to operate the valve.

SPECIFICATIONS

Valve Type	Globe Valve
Body Pattern	Two-way
Connection Type	NPT Female
Controlled Medium	Hot/Chilled Water with up to 50% Glycol
Flow characteristic	Equal percentage (water); Linear (steam)
Leakage Rating	Seat:- 0.05% of C _v
Maximum Safe Operating Pressure	217 psi at 248 F (1500 kPa at 120 C) V5011N2:100 psi (690 kPa) steam
Maximum Differential for Quiet Water Service	20 psid (138 kPa)
Ambient Temperature Range	36 F to 248 F water (2 C to 120 C water) 337 F (169 C) steam
Stem Travel	3/4 in. (20 mm)
Materials	
(Body)	Red Brass
(Stem)	Stainless Steel
(Seat)	Stainless Steel; reverse-acting: Brass
(Cartridge)	Brass
(Plug/Ball/Disc)	Teflon or carbon-loaded Teflon(R)
(Packing)	Teflon

APPROVALS

CRN Number 0C0861.9087YTN/0C0861.99

DIMENSIONS DIAGRAM

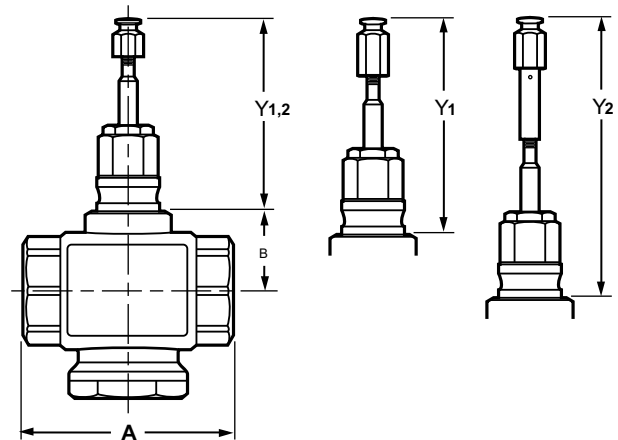

VALVE SIZE (IN)	A in. (mm)	B in. (mm)
1/2	3-1/4 (83)	1-9/16 (40)
3/4		
1	4-1/16 (103)	
1-1/4	4-3/16 (106)	
1-1/2	4-3/4 (120)	1-13/16 (47)
2	5-1/4 (134)	

VALVE	Y1 in. (mm)	Y2 ^a in. (mm)
V5011N1XXX	3-1/2 (89)	5-1/4 (133)
OR		
V5011N2XXX	STEM FULLY DOWN	
V5011N3XXX	4-3/16 (107)	5-15/16 (151)
	STEM FULLY UP	

^aY2 WITH STEM EXTENSION FOR MP953C,E (8 IN. ONLY)

M17378A

NPT Globe Valve

V5013N



The V5013N is a three-way threaded globe valve that controls hot water, cold water, and glycol solutions (up to 50 percent concentration) in heating or cooling HVAC applications. The valves are used for mixing service to direct flow from one or two inlets to a common outlet in two-position or modulating control systems.

FEATURES

- Red brass body with NPT-threaded connections.
- Stainless steel stem and brass plug.
- Low seat leakage rating, < 0.05%.
- Spring-loaded, self adjusting packing.
- 50:1 rangeability per VDI/VDE 2173.
- Constant total flow throughout full stem travel.
- Accurate positioning to ensure state-of-the-art temperature control.
- Sizes range from 1/2 to 2 in.
- Valves utilize direct mounting valve actuators, Q5020/ Q5022 linkages with Direct Coupled Actuators, or Pneumatic valve actuators to operate the valve.
- Repack and rebuild kits available for field servicing.

SPECIFICATIONS

Valve Type	Globe Valve
Body Pattern	Three-way
Connection Type	NPT Female
Controlled Medium	Hot/Chilled Water with up to 50% Glycol
Leakage Rating	0.05% of C_v
Maximum Safe Operating Pressure	217 psi at 248 F (1500 kPa at 120 C)
Maximum Differential for Quiet Water Service	20 psid (138 kPa)
Ambient Temperature Range	36 F to 248 F water (2 C to 120 C water)
Stem Travel	3/4 in. (20 mm)
Materials	
(Body)	Red Brass
(Stem)	Stainless Steel
(Seat)	Brass
(Plug/Ball/Disc)	Brass
(Packing)	Teflon/EPDM

APPROVALS

CRN Number 0C0861.9087YTN/0C0861.123

DIMENSIONS DIAGRAM

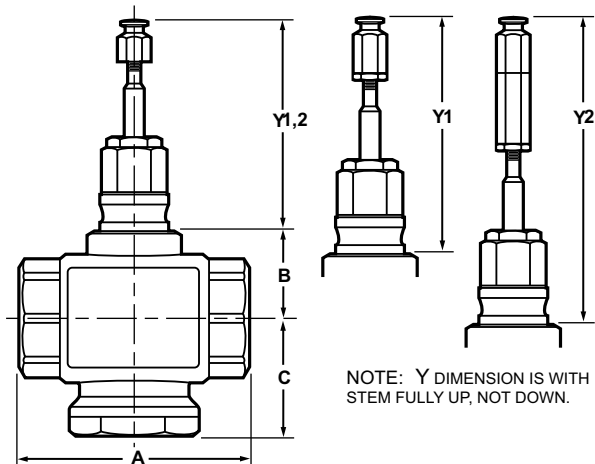

VALVE SIZE	A	B	C	Y ₁	Y ₂ ^a
				STEM UP	
1/2 (15)	3-1/4 (83)	1-9/16 (39.7)	2-9/16 (65)	4-3/16 (106)	5-15/16 (151)
3/4 (20)	3-1/4 (83)	1-9/16 (39.7)	2-9/16 (65)		
1 (25)	4-1/16 (103)	1-9/16 (39.7)	2-5/8 (66.5)		
1-1/4 (32)	4-3/16 (106)	1-9/16 (39.7)	2-7/8 (72.5)		
1-1/2 (40)	4-3/4 (120)	1-13/16 (46.5)	3 (77)		
2 (50)	5-1/4 (134)	1-13/16 (46.5)	3-5/16 (83.5)		

^a Y₂ WITH STEM EXTENSION FOR MP953C,E (8 IN. ONLY)

M12901A

Flanged Cage Valve

V5051A



Single-Seated Cage Valves control steam, air, liquids, or non-combustible gases in two-position, proportional, or floating control systems where line isolation is not required.

FEATURES

- Pressure balanced cage type construction.
- Low operating force allows fail safe operation with spring return actuator.
- Combines 1-3/8 in. bonnet with 1-1/2 in. stroke.
- Sizes range from 2-1/2 to 6 in. (DN65 to DN150).
- Spring-loaded Teflon® V-ring packing.
- Requires Q5020C valve linkage with one rotary, direct coupled actuator.

SPECIFICATIONS

Valve Type	Cage Valves
Body Pattern	Two-way, Straight-through
Connection Type	Flanged
Controlled Medium	Steam, Hot/Chilled Water with up to 50% Glycol
Leakage Rating	0.01% of C_v
	0.03% of C_v @ 5 & 6 in.
Maximum Safe Operating Pressure	140 psi water (965 kPa water) 55 psi steam (379 kPa steam)
Ambient Temperature Range	35 F to 300 F (2 C to 150 C)
Stem Travel	1 1/2 in. (39 mm)
Materials	
(Body)	Cast Iron
(Stem)	Stainless Steel
(Seat)	Resilient
(Plug/Ball/Disc)	Stainless Steel
(Packing)	Teflon

DIMENSIONS DIAGRAM

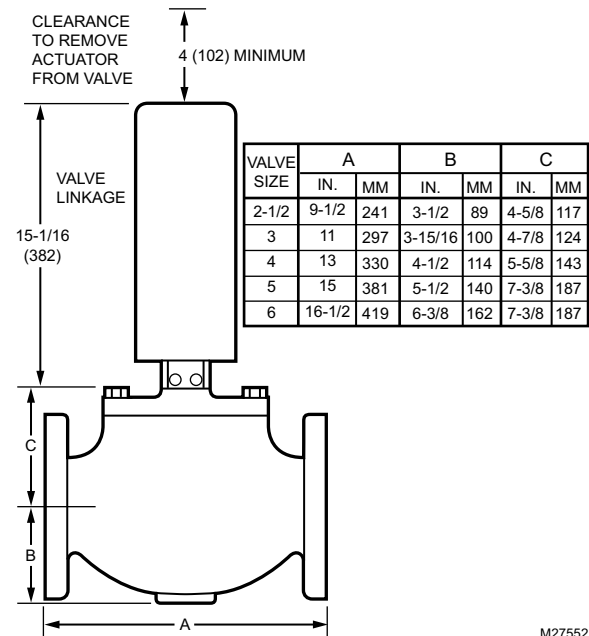

M27552

Flanged Globe Valve

V5011A,B



Used for proportional control of hot or chilled water and glycol solutions (to 50 percent concentration) and for two-position control of low pressure steam.

FEATURES

- Sizes range from 2-1/2 to 6 in.
- Stainless steel stem with removable Teflon disc.
- Valves utilize direct mounting valve actuators, Q5020/ Q5022 linkages with Direct Coupled Actuators, or Pneumatic Valve Actuators to operate the valve.
- Equal Percentage flow characteristic.

SPECIFICATIONS

Valve Type	Globe Valve
Body Pattern	Two-way
Flow Characteristic	Equal Percentage
Connection Type	Flanged
Controlled Medium	Steam, Hot/Chilled Water with up to 50% Glycol
Maximum Safe Operating Pressure	15 psi (100 kPa) steam 150 psi at 240 F water (1034 kPa at 115 C water)
Maximum Differential for Quiet Water Service	20 psid (138 kPa)
Ambient Temperature Range	40 F to 250 F (4 C to 121 C)
Stem Travel	3/4 in. (20 mm)
Materials	
(Body)	Cast Iron
(Stem)	Stainless Steel
(Seat)	Bronze
(Packing)	Teflon Cone

DIMENSIONS DIAGRAM

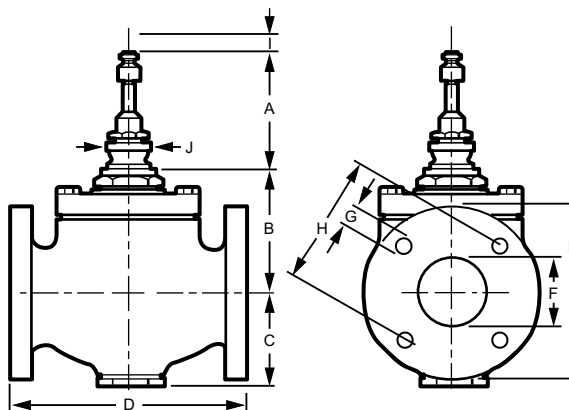

MODEL	VALVE SIZE	A ^a	B	C	D	E	F	G	H	I (TRAVEL)	J (DIAMETER)
V5011A	2-1/2 (64)	3-1/2 (89)	4-13/16 (122)	4 (102)	9-1/2 (241)	7 (178)	2-1/2 (64)	3/4 (19)	5-1/2 (140)	3/4 (19)	1-3/8 (35)
	3 (76)	3-1/2 (89)	3-1/2 (89)	4-5/8 (117)	11 (279)	7-1/2 (191)	3 (76)	3/4 (19)	6 (152)	3/4 (19)	1-3/8 (35)
	4 (102)	5-1/4 (133)	5-1/4 (133)	5-3/16 (132)	13 (330)	9 (229)	4 (102)	3/4 (19)	7-1/2 (191)	1-1/2 (38)	1-7/8 (48)
V5011B	4 (102)	6-3/4 (171)	6-3/4 (171)	8-1/16 (205)	13 (330)	9 (229)	4 (102)	3/4 (19)	7-1/2 (191)	1-1/2 (38)	1-7/8 (48)

M27256

Flanged Globe Valve

V5013B,C



The V5013B are three-way mixing valves. The V5013C are three-way diverting valves. These valves provide proportional or two-position control of hot or chilled water in heating or cooling systems. These valves are offered in sizes 2 1/2 in. through 6 in.

FEATURES

- Not suitable for combustible gases.
- Valves utilize direct mounting valve actuators, Q5020/Q5022 linkages with Direct Coupled Actuators, or Pneumatic Valve Actuators to operate the valve.
- Constant total flow through full plug travel.
- Stainless steel stem prevents corrosion.
- Class IV (0.01% of C_v) Leakage Rating.

SPECIFICATIONS

Valve Type	Globe Valve
Body Pattern	Three-way
Connection Type	Flanged
Controlled Medium	Hot/Chilled Water with up to 50% Glycol
Flow characteristic	Linear (constant total)
Maximum Safe Operating Pressure	150 psi at 240 F water (1034 kPa at 115 C water)
Maximum Differential for Quiet Water Service	20 psid (138 kPa)
Ambient Temperature Range	40 F to 250 F (4 C to 121 C)
Stem Travel	3/4 in. (20 mm)
Materials	
(Body)	Cast Iron
(Stem)	Stainless Steel
(Seat)	Bronze
(Packing)	Teflon Cone

DIMENSIONS DIAGRAM

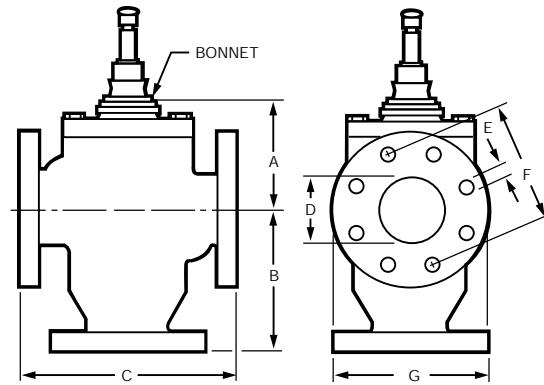

V5013B,C DIMENSIONS

VALVE SIZE IN INCHES (MM)					
	2-1/2 (64)	3 (76)	4 (102)	5 (125)	6 (152)
A	4-1/2 (114)	5-1/4 (133)	5-7/8 (149)	6-1/4 (159)	7-1/4 (184)
B	6-7/17 (164)	6-5/8 (168)	8-11/16 (221)	9-5/8 (244)	10-11/16 (271)
C	9-1/2 (241)	11 (279)	13 (330)	15 (381)	16-1/2 (419)
D	2-1/2 (64)	3 (76)	4 (102)	5 (127)	6 (152)
E	3/4 (19)	3/4 (19)	3/4 (19)	7/8 (22)	7/8 (22)
F	5-1/2 (140)	6 (152)	7-1/2 (191)	8-1/2 (216)	9-1/2 (241)
G	7 (178)	7-1/2 (191)	9 (229)	10 (254)	11 (279)

VALVE SIZE	BONNET SIZE	NUMBER OF BOLT HOLES
2-1/2 (64)	1-3/8 (35)	4
3 (76)		
4 (102)	1-7/8 (48)	8
5 (125)		
6 (152)		

C7959B

SUBMITTAL SHEETS

Flanged Globe Valve

VG F2



VG F Flanged Globe Valves are used for 2-position or modulating control of steam, hot water, or chilled water-glycol solutions up to 50 percent concentration in heating, ventilation and air conditioning (HVAC) systems. They can be operated by ML6984/7984, ML6420/6425, ML6421/7421 Electric Linear Actuators, MP953 Pneumatic Actuators, Modutrol™ Motors with Q5001 valve linkage, or MN/MS Series Direct Coupled Actuators with Q5020 valve linkage.

SPECIFICATIONS

Valve Type	Globe Valve
Body Pattern	Two-way
Flow characteristic	Equal percentage or Linear
Connection Type	Flanged
Valve Action	Step down to close
Controlled Medium	Hot/Chilled Water with up to 50% Glycol; Steam
Leakage Rating	0.05% of C_v
Maximum Safe Operating Pressure	400 psig (2750 kPa)
Maximum Differential Pressure Ratings (Close-off)	Varies with actuator force
Fluid Temperature Range	20 F to 250 F, steam 335 F (-7 C to 120 C, steam 180 C)
Actuation	Must be purchased separately
Stem Travel	
2-1/2 and 3 in. valves	3/4 in. (20 mm)
4 to 6 in. valves	1-1/2 in. (39 mm)
Bonnet Size	
2-1/2 and 3 in. valves	1-3/8 in. (35 mm)
4 to 6 in. valves	1-7/8 in. (47.6 mm)
Materials	
(Body)	Cast Iron ASTM A126 Class B
(Stem)	Stainless Steel
(Seat)	Stainless Steel
(Cartridge)	Stainless Steel
(Plug/Ball/Disc)	Stainless Steel
(Packing)	Spring-loaded PTFE cone rings

FEATURES

- ANSI Class 125 and Class 250 cast iron bodies with flanged end connections.
- Equal percentage and linear flow characteristics
- Face-to-face flange dimensions per ANSI/ISA S75.03 standard.
- Sizes from 2-1/2 to 6 in.
- Stainless steel trim standard for long life span.
- ANSI Class III seat leakage
- Steam inlet pressure up to 125 psig and 353 F maximum temperature.
- Self-adjusting packing.
- Accurate positioning with equal percentage and linear flow characteristics to ensure precise temperature control.
- Universal bonnet for direct-coupled electric and pneumatic actuators for easy mounting, or linkage coupled Modutrol™ Motors and MN/MS Series direct coupled actuators.
- Not suitable for combustible gasses.

DIMENSIONS DIAGRAM

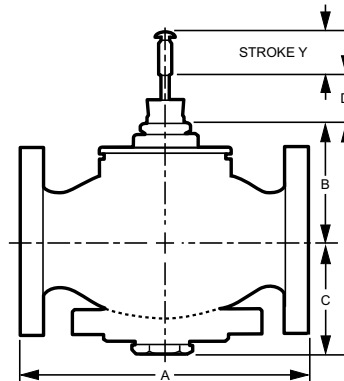

1 DOTTED LINE REPRESENTS ANSI 125 VALVE BONNET.

MODEL NUMBER	DIMENSIONS, IN. (MM)				
	A	B	C	E	Y
2-WAY VALVES, ANSI CLASS 125. STEM DOWN TO CLOSE. EQUAL PERCENTAGE OR LINEAR FLOW CHARACTERISTIC					
VG F21_S25	10-7/8 (276)	4-3/8 (112)	7 (178)	3-1/2 (89)	13/16 (20)
VG F21_S30	11-3/4 (298)	6-3/8 (161)	7-1/2 (191)		
VG F21_S40	13-7/8 (352)	5-7/8 (150)	9 (229)	5-1/4 (133)	1-1/2 (38)
VG F21_S50	15-3/4 (400)	6-3/16 (157)	10 (254)		
VG F21_S60	17-3/4 (451)	6-3/16 (157)	11 (279)		
2-WAY VALVES, ANSI CLASS 250. STEM DOWN TO CLOSE. EQUAL PERCENTAGE FLOW CHARACTERISTIC					
VG F22ES25	11-1/2 (292)	4-3/8 (112)	7-1/2 (191)	3-1/2 (89)	13/16 (20)
VG F22ES30	12-1/2 (318)	6-3/8 (161)	8-1/4 (210)		
VG F22ES40	14-1/2 (368)	5-7/8 (150)	10 (254)	5-1/4 (133)	1-1/2 (38)
VG F22ES50	16-5/8 (422)	6-3/16 (157)	11 (279)		
VG F22ES60	18-5/8 (473)	6-3/16 (157)	12-1/2 (318)		
2-WAY VALVES, PRESSURE-BALANCED, ANSI CLASS 125. STEM DOWN TO CLOSE. EQUAL PERCENTAGE OR LINEAR FLOW CHARACTERISTIC					
VG F21_P25	10-7/8 (276)	4-3/16 (107)	7 (178)	3-1/2 (89)	13/16 (20)
VG F21_P30	11-3/4 (298)	5-7/8 (150)	7-1/2 (191)		
VG F21_P40	13-7/8 (352)	5-7/8 (150)	9 (229)	5-1/4 (133)	1-1/2 (38)
VG F21_P50	15-3/4 (400)	6-1/8 (156)	10 (254)		
VG F21_P60	17-3/4 (451)	6-1/8 (156)	11 (279)		

M27603

Flanged Globe Valve

VG2 Pressure Balanced



VG2 Flanged Globe Valves are used for 2-position or modulating control of steam, hot water, or chilled water-glycol solutions up to 50 percent concentration in heating, ventilation and air conditioning (HVAC) systems. They can be operated by ML6984/7984, ML6420/6425, ML6421/7421 Electric Linear Actuators, MP953 Pneumatic Actuators, Modutrol™ Motors with Q5001 valve linkage, or

MN/MS Series Direct Coupled Actuators with Q5020 valve linkage. Pressure-balanced models feature very high, low leakage close-off ratings.

SPECIFICATIONS

Valve Type	Globe Valve
Body Pattern	Two-way
Flow characteristic	Equal percentage or Linear
Connection Type	Flanged
Valve Action	Step down to close
Controlled Medium	Hot/Chilled Water with up to 50% Glycol; Steam
Leakage Rating	0.01% of C_v
Maximum Safe Operating Pressure	175 psig (1206 kPa)
Maximum Differential Pressure Ratings (Close-off)	175 psi (1206 kPa)
Fluid Temperature Range	20 F to 250 F, steam 335 F (-7 C to 120 C, steam 180 C)
Actuation	Must be purchased separately
Stem Travel	
2-1/2 and 3 in. valves	3/4 in. (20 mm)
4 to 6 in. valves	1-1/2 in. (39 mm)
Bonnet Size	
2-1/2 and 3 in. valves	1-3/8 in. (35 mm)
4 to 6 in. valves	1-7/8 in. (47.6 mm)
Materials	
(Body)	Cast Iron ASTM A126 Class B
(Stem)	Stainless Steel
(Seat)	Stainless Steel
(Cartridge)	Stainless Steel
(Plug/Ball/Disc)	Stainless Steel
(Packing)	Spring-loaded PTFE cone rings

FEATURES

- ANSI Class 125 cast iron bodies with flanged end connections.
- Equal percentage and linear flow characteristics
- Face-to-face flange dimensions per ANSI/ISA S75.03 standard.
- Sizes from 2-1/2 to 6 in.
- Stainless steel trim standard for long life span.
- Differential pressure of 175 psi, ANSI Class IV.
- Steam inlet pressure up to 125 psig and 353 F maximum temperature.
- Self-adjusting packing.
- Accurate positioning with equal percentage and linear flow characteristics to ensure precise temperature control.
- Universal bonnet for direct-coupled electric and pneumatic actuators for easy mounting, or linkage coupled Modutrol™ Motors and MN/MS Series direct coupled actuators.
- Not suitable for combustible gasses.

DIMENSIONS DIAGRAM

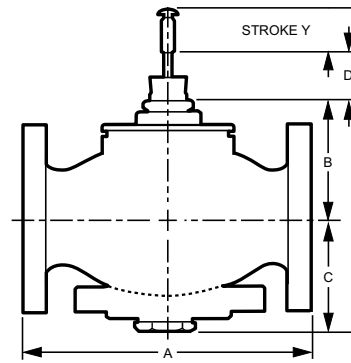

▲ DOTTED LINE REPRESENTS ANSI 125 VALVE BONNET.

MODEL NUMBER	DIMENSIONS, IN. (MM)				
	A	B	C	E	Y
2-WAY VALVES, ANSI CLASS 125. STEM DOWN TO CLOSE. EQUAL PERCENTAGE OR LINEAR FLOW CHARACTERISTIC					
VG21_S25	10-7/8 (276)	4-3/8 (112)	7 (178)	3-1/2 (89)	13/16 (20)
VG21_S30	11-3/4 (298)	6-3/8 (161)	7-1/2 (191)		
VG21_S40	13-7/8 (352)	5-7/8 (150)	9 (229)	5-1/4 (133)	1-1/2 (38)
VG21_S50	15-3/4 (400)	6-3/16 (157)	10 (254)		
VG21_S60	17-3/4 (451)	6-3/16 (157)	11 (279)		
2-WAY VALVES, ANSI CLASS 250. STEM DOWN TO CLOSE. EQUAL PERCENTAGE FLOW CHARACTERISTIC					
VG22ES25	11-1/2 (292)	4-3/8 (112)	7-1/2 (191)	3-1/2 (89)	13/16 (20)
VG22ES30	12-1/2 (318)	6-3/8 (161)	8-1/4 (210)		
VG22ES40	14-1/2 (368)	5-7/8 (150)	10 (254)	5-1/4 (133)	1-1/2 (38)
VG22ES50	16-5/8 (422)	6-3/16 (157)	11 (279)		
VG22ES60	18-5/8 (473)	6-3/16 (157)	12-1/2 (318)		
2-WAY VALVES, PRESSURE-BALANCED, ANSI CLASS 125. STEM DOWN TO CLOSE. EQUAL PERCENTAGE OR LINEAR FLOW CHARACTERISTIC					
VG21_P25	10-7/8 (276)	4-3/16 (107)	7 (178)	3-1/2 (89)	13/16 (20)
VG21_P30	11-3/4 (298)	5-7/8 (150)	7-1/2 (191)		
VG21_P40	13-7/8 (352)	5-7/8 (150)	9 (229)	5-1/4 (133)	1-1/2 (38)
VG21_P50	15-3/4 (400)	6-1/8 (156)	10 (254)		
VG21_P60	17-3/4 (451)	6-1/8 (156)	11 (279)		

M27603

Flanged Globe Valve

VG F3



VG F Flanged Globe Valves are used for 2-position or modulating control of hot water or chilled water-glycol solutions up to 50 percent concentration in heating, ventilation and air conditioning (HVAC) systems. They can be operated by ML6984/7984, ML6420/6425, ML6421/7421 Electric Linear Actuators, MP953 Pneumatic Actuators, Modutrol™ Motors with Q5001 valve linkage, or MN/MS

Series Direct Coupled Actuators with Q5020/Q5022 valve linkages. Three-way bodies are available in mixing or diverting style with equal percentage and linear flow characteristics, respectively.

SPECIFICATIONS

Valve Type	Globe Valve
Body Pattern	Three-way mixing; diverting
Flow characteristic	A-port - Equal percentage mixing, Linear Diverting B-port - Linear
Connection Type	Flanged
Controlled Medium	Hot/Chilled Water with up to 50% Glycol
Fluid Temperature Range	20 F to 250 F (-7 C to +20 C)
Stem Travel	
2-1/2 and 3 in. valves	3/4 in. (20 mm)
4 to 6 in. valves	1-1/2 in. (39 mm)
Bonnet Size	
2-1/2 and 3 in. valves	1-3/8. (35 mm)
4 to 6 in. valves	1-7/8 in. (47.6 mm)
Actuation	Must be purchased separately
Materials	
(Body)	Cast Iron ASTM A126 Class B
(Stem)	Stainless Steel
(Seat)	Stainless Steel
(Cartridge)	Stainless Steel
(Plug/Ball/Disc)	Stainless Steel
(Packing)	Spring-loaded PTFE cone rings

FEATURES

- ANSI Class 125 and Class 250 cast iron bodies with flanged end connections.
- Face-to-face flange dimensions per ANSI/ISA S75.03 standard.
- Sizes from 2-1/2 to 6 in.
- Stainless steel trim standard for long life span.
- Self-adjusting packing.
- Accurate positioning with equal percentage and linear flow characteristics to ensure precise temperature control.
- Universal bonnet for direct-coupled electric and pneumatic actuators for easy mounting, or linkage coupled Modutrol™ Motors and MN/MS Series direct coupled actuators.
- Constant total flow throughout full plug travel (3-way diverting models).

DIMENSIONS DIAGRAM

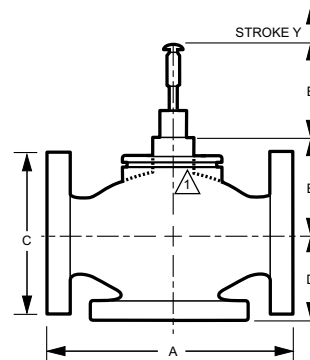

1 DOTTED LINE REPRESENTS ANSI 125 VALVE BONNET.

MODEL NUMBER	DIMENSIONS, IN. (MM)					
	A	B	C	D	E	Y
3-WAY MIXING VALVES, ANSI CLASS 125. STEM UP TO CLOSE A-AB						
VG F31EM25	10-7/8 (276)	3 (76)	7 (178)	3-3/4 (95)	4-3/16 (107)	13/16 (20)
VG F31EM30	11-3/4 (298)	4-3/16 (107)	7-1/2 (191)	4-3/8 (111)		
VG F31EM40	13-7/8 (352)	5-8/16 (140)	9 (229)	5-1/8 (130)	6-11/16 (170)	1-1/2 (38)
VG F31EM50	15-3/4 (400)	5-3/8 (137)	10 (254)	5-3/4 (146)		
VG F31EM60	17-3/4 (451)	5-11/16 (145)	11 (279)	6-5/8 (168)		
3-WAY MIXING VALVES, ANSI CLASS 250. STEM UP TO CLOSE A-AB						
VG F32EM25	11-1/2 (292)	4-3/8 (112)	7-1/2 (191)	3-3/4 (95)	4-3/16 (107)	13/16 (20)
VG F32EM30	12-1/2 (318)	6-3/8 (161)	8-1/4 (210)	4-3/8 (111)		
VG F32EM40	14-1/2 (368)	5-7/8 (150)	10 (254)	5-1/8 (130)	6-11/16 (170)	1-1/2 (38)
VG F32EM50	16-5/8 (422)	6-3/16 (157)	11 (279)	5-3/4 (146)		
VG F32EM60	18-5/8 (473)	6-3/16 (157)	12-1/2 (318)	6-5/8 (168)		
3-WAY DIVERTING VALVES, ANSI CLASS 125. STEM DOWN TO CLOSE AB-A						
VG F31LD25	10-7/8 (276)	3 (76)	7 (178)	3-3/4 (95)	4-3/16 (107)	13/16 (20)
VG F31LD30	11-3/4 (298)	4-3/16 (107)	7-1/2 (191)	4-3/8 (111)		
VG F31LD40	13-7/8 (352)	5-8/16 (140)	9 (229)	5-1/8 (130)	6-11/16 (170)	1-1/2 (38)
VG F31LD50	15-3/4 (400)	5-3/8 (137)	10 (254)	5-3/4 (146)		
VG F31LD60	17-3/4 (451)	5-11/16 (145)	11 (279)	6-5/8 (168)		
3-WAY DIVERTING VALVES, ANSI CLASS 250. STEM DOWN TO CLOSE AB-A						
VG F32LD25	11-1/2 (292)	4-3/8 (112)	7-1/2 (191)	3-3/4 (95)	4-3/16 (107)	13/16 (20)
VG F32LD30	12-1/2 (318)	6-3/8 (161)	8-1/4 (210)	4-3/8 (111)		
VG F32LD40	14-1/2 (368)	5-7/8 (150)	10 (254)	5-1/8 (130)	6-11/16 (170)	1-1/2 (38)
VG F32LD50	16-5/8 (422)	6-3/16 (157)	11 (279)	5-3/4 (146)		
VG F32LD60	18-5/8 (473)	6-3/16 (157)	12-1/2 (318)	6-5/8 (168)		

M27604

Resilient Seat Butterfly Valves

VFF1



Resilient seat in two-way valves, provide control for HVAC system applications including chilled water, hot water, cooling tower water, thermal storage systems, and steam.

SPECIFICATIONS

Body Pattern	2 way (S/R NO)
Valve Action	Normally Open
Connection Type	Lugged
Controlled Medium	Chilled and hot water, up to 50% glycol
Actuator Control Type	Pneumatic, Spring Return
Type of Enclosure	Pneumatic
Flow Characteristic	Modified Equal Percent
Mounting	ANSI Flanged
Static Pressure Rating (max)	250 psi (1724 kPa)
Maximum Differential Pressure Ratings (Close-off)	175 psi (1206 kPa)
Actuator Ambient Temperature Ratings	-20 F to 150 F (-29 C to 66 C)
Temperature Range	-40 F to 250 F (-40 C to 121 C)
Materials	
(Body)	Polyester-coated cast iron ASTM A126 Class B
(Stem)	416 stainless steel
(Seat)	Peroxide-cured EPDM resilient seat
(Plug/Ball/Disc)	Nylon 11-coated ductile iron

DIMENSIONS DIAGRAM

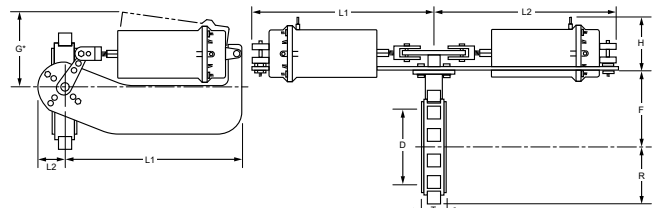

PIPE SIZE IN. [mm]	FULL CUT DISK, 175 PSI CLOSE-OFF (VFF1/2, W1Y8/PP)					UNDER CUT DISK, 50 PSI CLOSE-OFF** (VFF1/2, V1Y8/PP)				
	G	H	HP	L1	L2	G	H	HP	L1	L2*
2 [DN50]										
2-1/2 [DN65]	5-5/8 [144]	3-1/8 [79]	6-1/4 [160]	16 [406]						
3 [DN80]					3 [76]					
4 [DN100]	7-1/4 [186]		10 [254]	20 [508]		5-5/8 [144]	3-1/8 [79]	5-1/4 [160]	16 [406]	
5 [DN125]						7-1/4 [186]		10 [254]	20 [508]	3 [76]
6 [DN150]	9 [227]	6-7/8 [175]	10-1/8 [257]	22-3/4 [578]						
8 [DN200]					22-3/4 [578]	9 [227]	6-7/8 [175]	10-1/8 [257]	22-3/4 [578]	
10 [DN250]	LOW PRESSURE ACTUATORS NOT AVAILABLE IN THESE, AND LARGER BODY SIZES.									22-3/4 [578]
12 [DN300]	LOW PRESSURE ACTUATORS NOT AVAILABLE IN THESE, AND LARGER BODY SIZES.									22-3/4 [578]

**NOTE: VALVE SIZES 2 TO 3 INCHES ARE AVAILABLE ONLY WITH FULL CUT DISKS. VALVE STROKE IS LIMITED TO 70 DEGREES.

M270

SUBMITTAL SHEETS

Resilient Seat Butterfly Valves

VFF2



Resilient seat two-way valves provide control for HVAC system applications including chilled water, hot water, cooling tower water, thermal storage systems, and steam.

SPECIFICATIONS

Body Pattern	2 way (NC, NC/NO; NSR)
Valve Action	Normally Closed, convertible to Normally Open with Spring Return DCA
Connection Type	Lugged
Controlled Medium	Chilled and hot water, up to 50% glycol
Actuator Control Type	Electric floating, and modulating; pneumatic spring and non-spring return
Type of Enclosure	NEMA 2 housing, DCA, NEMA 4 industrial electric, pneumatic linear
Flow Characteristic	Modified Equal Percent
Mounting	ANSI Flanged
Static Pressure Rating (max)	250 psi (1724 kPa)
Maximum Differential Pressure Ratings (Close-off)	175 psi (1206 kPa)
Actuator Ambient Temperature Ratings	-5 F to 140 F (-20 C to 60 C)
Temperature Range	-40 F to 250 F (-40 C to 121 C)
Materials	
(Body)	Polyester-coated cast iron
(Stem)	ASTM A126 Class B
(Seat)	416 stainless steel
(Plug/Ball/Disc)	Peroxide-cured EPDM resilient seat
(Plug/Ball/Disc)	Nylon 11-coated ductile iron

APPROVALS

CE	Compliant
Underwriters Laboratories, Inc.	C/US UL873, Plenum Rated

DIMENSIONS DIAGRAM

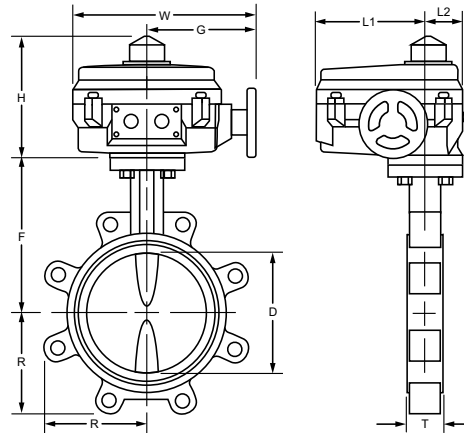

PIPE SIZE IN. [mm]	FULL CUT DISK, HIGH CLOSE-OFF* NEMA 4X (VFF2_W1YXA/B)					UNDER CUT DISK, 50 PSI CLOSE-OFF** NEMA 4X (VFF2_V1YXA/B)				
	W	H1	L1	L2	G	W	H1	L1	L2	G
2 [DN50]										
2-1/2 [DN65]	7-1/2 [191]	6-3/4 [170]	5-1/2 [141]	2 [51]	5-3/4 [147]					
3 [DN80]										
4 [DN100]						7-1/2 [191]	6-3/4 [170]	5-1/2 [141]	2 [51]	5-3/4 [147]
5 [DN125]										
6 [DN150]	10-1/8 [257]	8-1/8 [206]	7-3/8 [188]	2-3/4 [68]	7-3/4 [198]					
8 [DN200]						10-1/8 [257]	8-1/8 [206]	7-3/8 [188]	2-3/4 [68]	7-3/4 [198]
10 [DN250]										
12 [DN300]	12-1/8 [307]	8-3/4 [224]	8-7/8 [226]	3-1/4 [81]	9-1/2 [241]					
14 [DN350]										
16 [DN400]	NEMA 4 (VFF2_W1Y4A/4B)					12-1/8 [307]	8-3/4 [224]	8-7/8 [226]	3-1/4 [81]	9-1/2 [241]
18 [DN450]	8-1/2 [217]	16 [406]	8-3/4 [221]	4-1/2 [115]	12-1/2 [320]					
20 [DN500]						NEMA 4 (VFF2_V1Y4A/4B)				
						8-1/2 [217]	16 [406]	8-3/4 [221]	4-1/2 [115]	12-1/2 [320]

* 175 PSI [1206 KPA] CLOSE-OFF UP TO 12 INCHES [DN 300], 150 PSI [1034 KPA] OTHERWISE
 **NOTE: VALVE SIZES 2 TO 3 INCHES HAVE 175 PSI [1206 KPA] CLOSE-OFF AND ARE AVAILABLE ONLY WITH FULL CUT DISKS.

▲ NEMA 4X ACTUATORS ARE WATERPROOF AND CORROSION-RESISTANT.

M27011

WITH NEMA 4/4X ACTUATORS

Resilient Seat Butterfly Valves

VFF3



Resilient seat three-way valves provide control for HVAC system applications including chilled water, hot water, cooling tower water, thermal storage systems, and steam.

SPECIFICATIONS

Body Pattern	3 way (A-B-AB)
Valve Action	Normally Closed
Connection Type	Lugged
Controlled Medium	Chilled and hot water, up to 50% glycol
Actuator Control Type	Electric floating, and modulating; pneumatic spring and non-spring return
Type of Enclosure	NEMA 2 housing, DCA, NEMA 4 industrial electric, pneumatic linear
Flow Characteristic	Modified Equal Percent
Mounting	ANSI Flanged
Static Pressure Rating (max)	250 psi (1724 kPa)
Maximum Differential Pressure Ratings (Close-off)	175 psi (1206 kPa)
Actuator Ambient Temperature Ratings	-5 F to 140 F (-20 C to 60 C)
Temperature Range	-40 F to 250 F (-40 C to 121 C)
Materials (Body)	Polyester-coated cast iron ASTM A126 Class B
(Stem)	416 stainless steel
(Seat)	Peroxide-cured EPDM resilient seat
(Plug/Ball/Disc)	Nylon 11-coated ductile iron

APPROVALS

CE	Compliant
Underwriters Laboratories, Inc.	C/US UL873, Plenum Rated

DIMENSIONS DIAGRAM

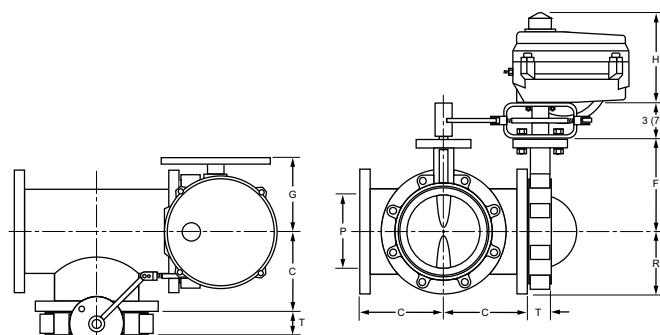

PIPE SIZE IN. [mm]	FULL CUT DISK, 175 PSI CLOSE-OFF NEMA 4X (VFF3/6_W1YXA/B)					UNDER CUT DISK, 50 PSI CLOSE-OFF** NEMA 4X (VFF3/6_V1YXA/B)				
	W	H	L1	L2	G	W	H	L1	L2	G
2 [DN50]										
2-1/2 [DN65]	7-1/2 [191]	6-3/4 [170]	5-1/2 [141]	2 [49]	5-3/4 [147]					
3 [DN80]										
4 [DN100]						7-1/2 [191]	6-3/4 [170]	5-1/2 [141]	2 [49]	5-3/4 [147]
5 [DN125]	10-1/8 [257]	8-1/8 [206]	7-3/8 [188]	2-3/4 [68]	7-3/4 [198]					
6 [DN150]						10-1/8 [257]	8-1/8 [206]	7-3/8 [188]	2-3/4 [68]	7-3/4 [198]
8 [DN200]										
10 [DN250]	12-1/8 [307]	8-3/4 [224]	8-7/8 [226]	3-1/4 [81]	9-1/2 [241]					
12 [DN300]						12-1/8 [307]	8-3/4 [224]	8-7/8 [226]	3-1/4 [81]	9-1/2 [241]
14 [DN350]	NEMA 4 (VFF3/6_W1Y4A/4B)									
16 [DN400]										
18 [DN450]	8-1/2 [217]	16 [406]	8-3/4 [221]	4-1/2 [115]	12-1/2 [320]	NEMA 4 (VFF3/6_V1Y4A/4B)				
20 [DN500]						8-1/2 [217]	16 [406]	8-3/4 [221]	4-1/2 [115]	12-1/2 [320]

* 175 PSI [1206 KPA] CLOSE-OFF UP TO 12 INCHES [DN 300], 150 PSI [1034 KPA] OTHERWISE
 **NOTE: VALVE SIZES 2 TO 3 INCHES HAVE 175 PSI [1206 KPA] CLOSE-OFF AND ARE AVAILABLE ONLY WITH FULL CUT DISKS. M27020

WITH NEMA 4/4X ACTUATORS

SUBMITTAL SHEETS

Resilient Seat Butterfly Valves

VFF6



Resilient seat three-way valves provide control for HVAC system applications including chilled water, hot water, cooling tower water, thermal storage systems, and steam.

SPECIFICATIONS

Body Pattern	3 way (A-AB-B)
Valve Action	Normally Closed
Connection Type	Lugged
Controlled Medium	Chilled and hot water, up to 50% glycol
Actuator Control Type	Electric floating, and modulating; pneumatic spring and non-spring return
Type of Enclosure	NEMA 2 housing, DCA, NEMA 4 industrial electric, pneumatic linear
Flow Characteristic	Modified Equal Percent
Mounting	ANSI Flanged
Static Pressure Rating (max)	250 psi (1724 kPa)
Maximum Differential Pressure Ratings (Close-off)	175 psi (1206 kPa)
Actuator Ambient Temperature Ratings	-5 F to 140 F (-20 C to 60 C)
Temperature Range	-40 F to 250 F (-40 C to 121 C)
Materials	
(Body)	Polyester-coated cast iron
(Stem)	ASTM A126 Class B
(Seat)	416 stainless steel
(Plug/Ball/Disc)	Peroxide-cured EPDM resilient seat
	Nylon 11-coated ductile iron

APPROVALS

CE	Compliant
Underwriters Laboratories, Inc.	C/US UL873, Plenum Rated

DIMENSIONS DIAGRAM

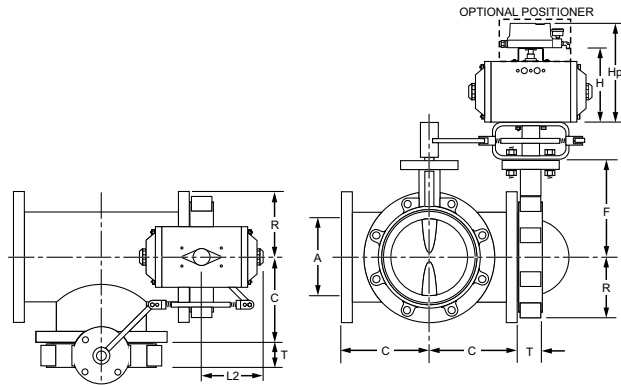

PIPE SIZE IN. [mm]	FULL CUT DISK, HIGH CLOSE-OFF* (VFF3/6_W1YCS/DS/ES/PS/XS)					UNDER CUT DISK, 50 PSI CLOSE-OFF** (VFF3/6_V1YCS/DS/ES/PS/XS)				
	W	H	HP	L1	L2	W	H	HP	L1	L2
2 [DN50]	2-3/4 [70]	4-1/4 [109]	10-1/4 [262]	3 [76]	3 [76]					
2-1/2 [DN65]	3-5/8 [91]	5-2/8 [132]	11-2/8 [284]	4 [100]	4 [100]					
3 [DN80]	4 [100]	5-1/2 [141]	11-1/2 [293]	4-1/2 [113]	4-1/2 [113]					
4 [DN100]	4-3/4 [120]	6-7/8 [176]	12-7/8 [328]	6 [154]	6 [154]	4 [100]	5-1/2 [141]	11-1/2 [293]	4-1/2 [113]	4-1/2 [113]
5 [DN125]	5-3/8 [137]	7-3/4 [196]	13-3/4 [349]	6-1/8 [157]	6-1/8 [157]	4-3/4 [120]	6-7/8 [176]	12-7/8 [328]	6 [154]	6 [154]
6 [DN150]	6-3/4 [172]	9-3/8 [238]	15-3/8 [391]	7-3/4 [196]	7-3/4 [196]	6-3/4 [172]	9-3/8 [238]	15-3/8 [391]	7-3/4 [196]	7-3/4 [196]
8 [DN200]	8-7/8 [224]	11-5/8 [295]	17-5/8 [447]	9-1/2 [240]	9-1/2 [240]	8-7/8 [224]	11-5/8 [295]	17-5/8 [447]	9-1/2 [240]	9-1/2 [240]
10 [DN250]										
12 [DN300]	10-3/4 [273]	13-1/2 [342]	19-1/2 [495]	13-3/8 [339]	13-3/8 [339]					
14 [DN350]										
16 [DN400]										
18 [DN450]						10-3/4 [273]	13-1/2 [342]	19-1/2 [495]	13-3/8 [339]	13-3/8 [339]
20 [DN500]										

* 175 PSI [1206 KPA] CLOSE-OFF UP TO 12 INCHES [DN 300], 150 PSI [1034 KPA] AT 14 INCHES AND NO PRODUCT AVAILABLE GREATER THAN 14 INCHES.

**NOTE: VALVE SIZES 2 TO 3 INCHES ARE AVAILABLE ONLY WITH FULL CUT DISKS. M27023

WITH PNEUMATIC SPRING RETURN ACTUATORS



Use the Q605 linkage kit to connect Modutrol® motor to standard damper or set of dampers to provide control of duct airflow.

FEATURES

- Adjustable to any degree of damper opening. Include ball joints, motor crank arm and damper arm for 1/2 in. (13 mm) diameter shaft.
- 27520 pushrod must be ordered separately.

SPECIFICATIONS

Linkage Type	Damper
Mounting	Mount motor externally on duct
Used with Actuator	Modutrol Motor

Valve Linkage

Q5001



The Q5001 Valve Linkage connects a Modutrol® Motor to a 2- or 3-way valve. It is used primarily on V5011 or V5013 steam and water valves.

SPECIFICATIONS

Linkage Type	Valve
Mounting	Linkage mounts directly to the valve bonnet; motor mounts on linkage bracket.
Used with Actuator	Modutrol Motor
Stem Force Rating	80 or 160 lbf (356 N or 712 N)
Ambient Temperature Range	-40 F to 150 F (-40 C to 66 C)

REPLACEMENT PARTS

220845/0767—Retainer button for Q5001

FEATURES

- Q5001 Valve Linkage is applicable to 2-Way or 3-Way valves in modulating or two-position service.
- Linkage requires no adjustment when used with Honeywell valves and Modutrol IV™ Motors.
- Q5001 Valve Linkage replaces Q601 and Q618 Valve Linkages.
- Linkage mounts directly to the valve bonnet; motor mounts to linkage bracket.
- Easy-to-read position indicator.
- Valve stem lift height cam selectable.
- Overtravel permits tight close-off without excessive motor strain.
- Available brackets make linkages adaptable to many valve bodies.
- Models available with 80 lb, 160 lb, and 320 lb stem force.
- Reversible cams on the Q5001 allow field selection of normally open or normally closed valve operation.
- All models have anti-spin clips.

DIMENSIONS DIAGRAM

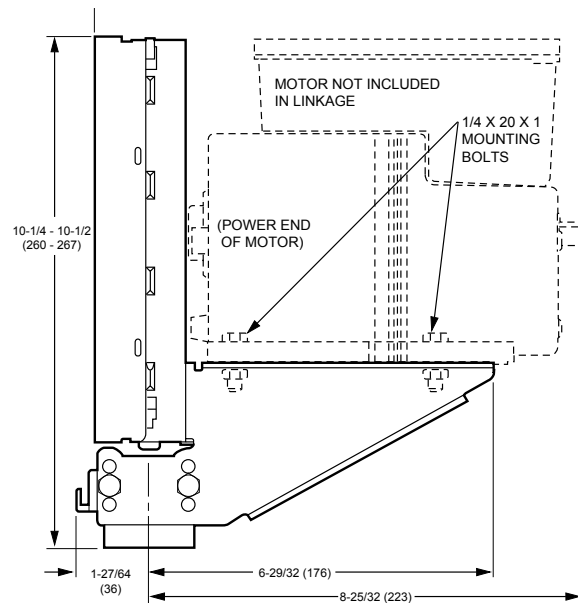

M13993



The Q5020 Globe Valve Linkages connect a Honeywell direct coupled actuator (DCA) to a steam or water globe valve. The Q5020 Linkages are compatible with two-way and three-way globe valves up to 3 in. (DN80).

FEATURES

- Used with two-way and three-way globe valves in modulating or two-position service.
- Used with 25, 50, and 142 lb-in. spring return and 35, 70, 150, and 300 lb-in. non-spring return DCA.
- Quick and simple installation with no disassembly required.
- Heavy-duty Steel rack and pinion construction and aluminum die-cast housing.
- Maintenance-free construction.
- Precision roller-bearing rack construction prevents premature valve packing wear and leakage.
- Flexible actuator mounting orientation.
- Adjustable manual override lever and valve position indicator.
- Can be mounted on specific non-Honeywell valves using a 32004629 Bonnet Adapter Kit.

SPECIFICATIONS

Linkage Type	Valve
Mounting	Linkage mounts directly to the valve bonnet; motor mounts on linkage
Used with Actuator	Direct Coupled Actuator

DIMENSIONS DIAGRAM

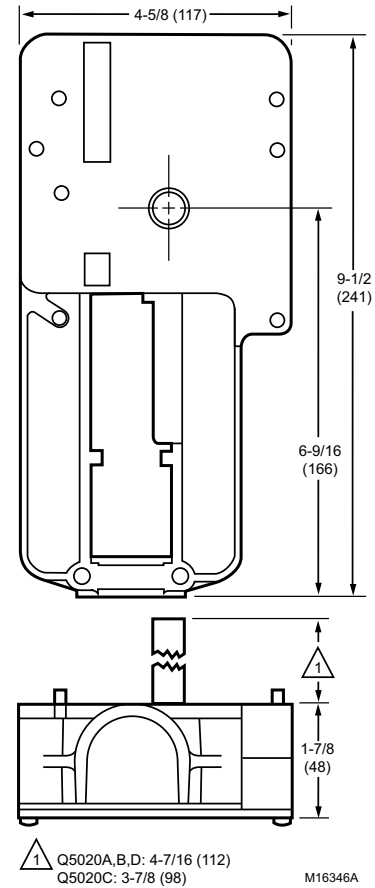

SUBMITTAL SHEETS

Globe Valve Linkage

Q5022



The Q5022A,B Globe Valve Linkages connect one or two Honeywell direct coupled rotary actuators (DCA) to a globe valve for control of chilled water, hot water, or steam. The Q5022A,B Linkages are compatible with 2 and 3-way globe valves up to 6 in. (DN150) pipe size.

Q5022A is used to provide enhanced close-off ratings with Honeywell globe valves up to 3 in. with 1-3/8 in. diameter bonnet and 3/4 in. stem stroke.

Q5022B is used with Honeywell globe valves 4 to 6 in. with 1-7/8 in. diameter bonnet and 1-1/2 in. stem stroke.

SPECIFICATIONS

Linkage Type	Valve
Mounting	Linkage mounts directly to the valve bonnet; motor mounts on linkage
Used with Actuator	Direct Coupled Actuator
Stem Force Rating	1117 lbf max. (4969 N max.)

FEATURES

- For use with 2-way and 3-way globe valves in modulating or two-position service.
- For use with 175 lb.-in. (S20) spring return or 175 and 300 lb.-in. (N20, N34) non-spring return DCAs.
- Accepts single or dual matching actuators for higher close-off pressures.
- Fail-safe operation with spring return DCAs, field selectable normally open or normally closed for direct or reverse-acting valves.
- Linkage threads onto valve stem.
- Oilite™ self-lubricated actuator shaft bearing.
- Anodized extruded aluminum housing.
- Maintenance-free construction.
- Precision roller-bearing rack construction to prevent premature valve packing wear and leakage.
- Flexible actuator mounting orientation.

DIMENSIONS DIAGRAM

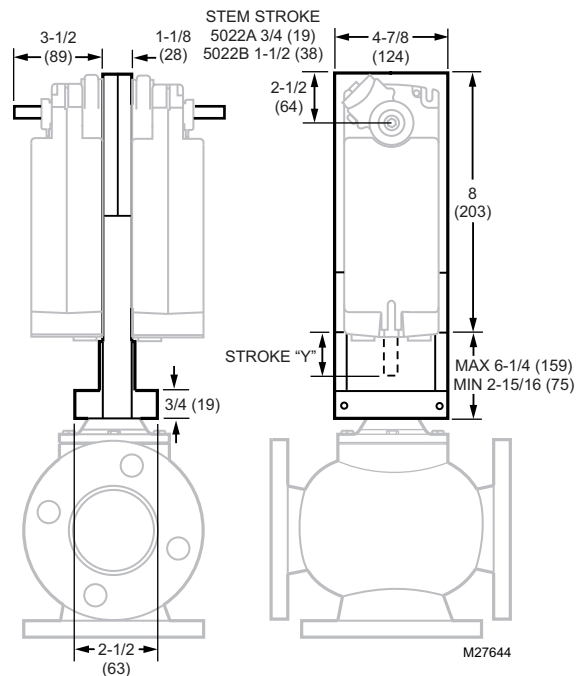

Section 4: Wiring Diagrams

Actuator Wiring Diagrams 154

Actuator Wiring Diagrams

Direct Coupled Actuators - Spring Return Models

S03 Series (MS4103, MS7403, MS7503, MS8103) and
S05 Series (MS4105, MS7105, MS7405, MS7505, MS8105)

Wiring for low-voltage two-position control

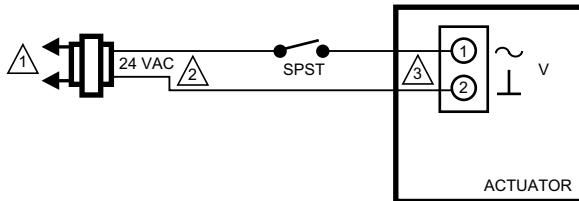

- 1 LINE VOLTAGE POWER SUPPLY. PROVIDE DISCONNECT MEANS AND OVERLOAD PROTECTION AS REQUIRED.
- 2 24 VDC SUPPLY ACCEPTABLE.
- 3 ENSURE PROPER GROUNDING OF ACTUATOR CASE.

M19718C

Wiring for line-voltage two-position control

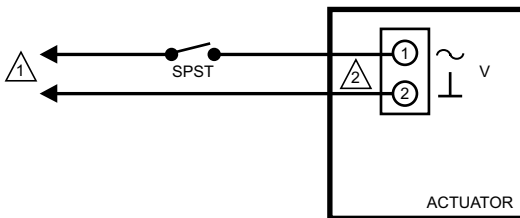

- 1 LINE VOLTAGE POWER SUPPLY. PROVIDE DISCONNECT MEANS AND OVERLOAD PROTECTION AS REQUIRED.
- 2 ENSURE PROPER GROUNDING OF ACTUATOR CASE.

M22289A

Wiring for SPDT on/off Control

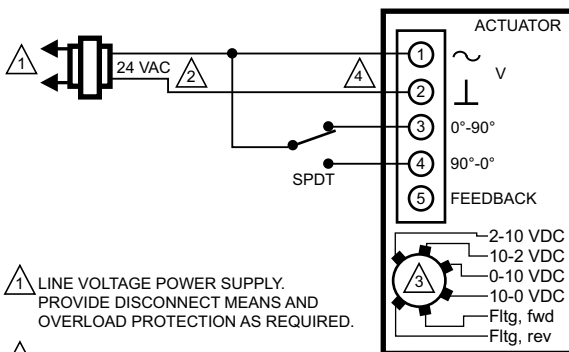

- 1 LINE VOLTAGE POWER SUPPLY. PROVIDE DISCONNECT MEANS AND OVERLOAD PROTECTION AS REQUIRED.
- 2 24 VDC SUPPLY ACCEPTABLE.
- 3 SET SWITCH TO FLOATING.
- 4 ENSURE PROPER GROUNDING OF ACTUATOR CASE.

M27822

Wiring for floating control

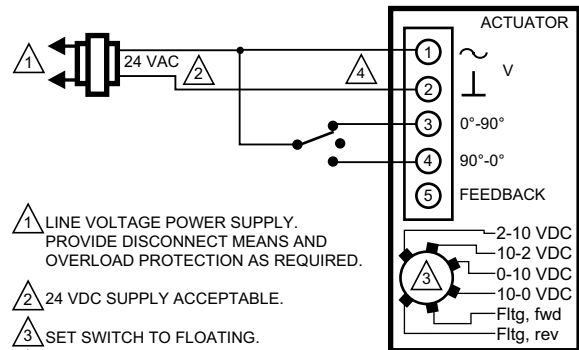

- 1 LINE VOLTAGE POWER SUPPLY. PROVIDE DISCONNECT MEANS AND OVERLOAD PROTECTION AS REQUIRED.
- 2 24 VDC SUPPLY ACCEPTABLE.
- 3 SET SWITCH TO FLOATING.
- 4 ENSURE PROPER GROUNDING OF ACTUATOR CASE.

M27823

Wiring for (0)2-10 VDC proportioning controllers

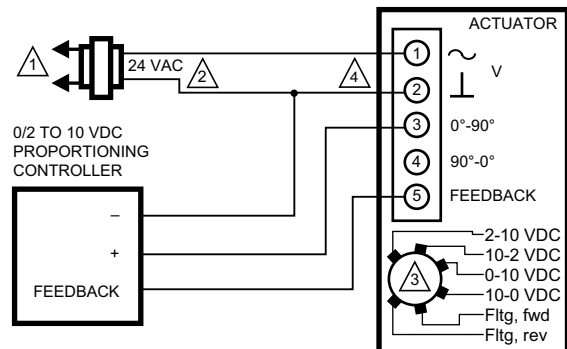

- 1 LINE VOLTAGE POWER SUPPLY. PROVIDE DISCONNECT MEANS AND OVERLOAD PROTECTION AS REQUIRED.
- 2 24 VDC SUPPLY ACCEPTABLE.
- 3 SET SWITCH TO MODULATING.
- 4 ENSURE PROPER GROUNDING OF ACTUATOR CASE.

M27824

Wiring for 4-20 mA proportioning controllers

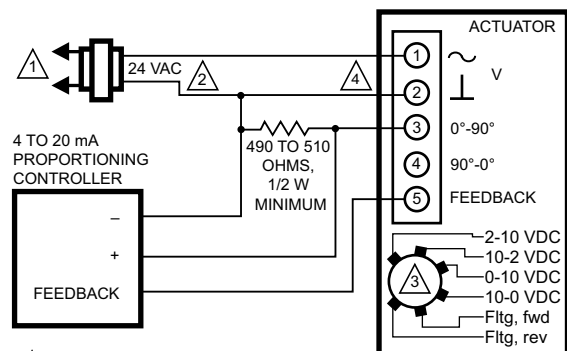

- 1 LINE VOLTAGE POWER SUPPLY. PROVIDE DISCONNECT MEANS AND OVERLOAD PROTECTION AS REQUIRED.
- 2 24 VDC SUPPLY ACCEPTABLE.
- 3 SET SWITCH TO MODULATING.
- 4 ENSURE PROPER GROUNDING OF ACTUATOR CASE.

M27825

Actuator Wiring Diagrams

Direct Coupled Actuators - Spring Return Models

Direct Coupled Actuators - Spring Return Models

Wiring for (0)2-10 Vdc proportioning controller operating multiple actuators

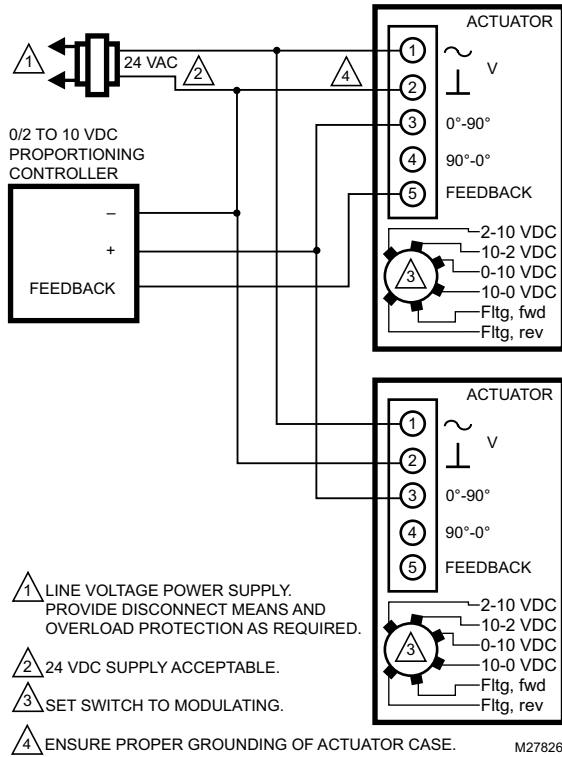

Wiring for 3 kOhm Economizer controllers

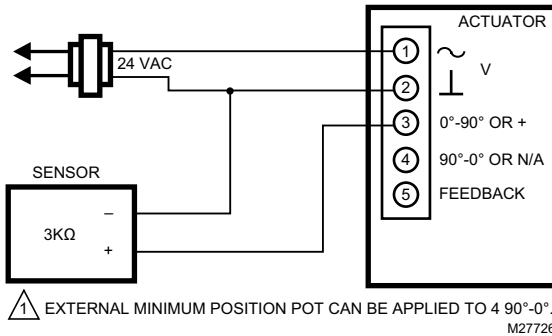

Wiring for 3 position Economizer controllers

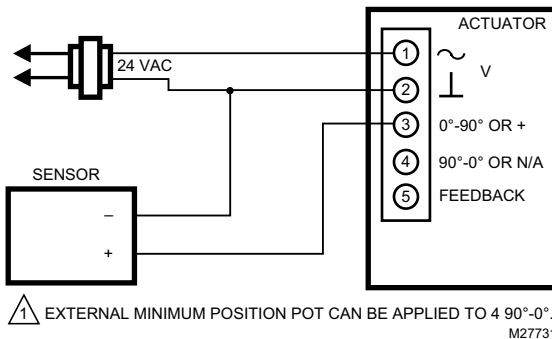

Override to full open

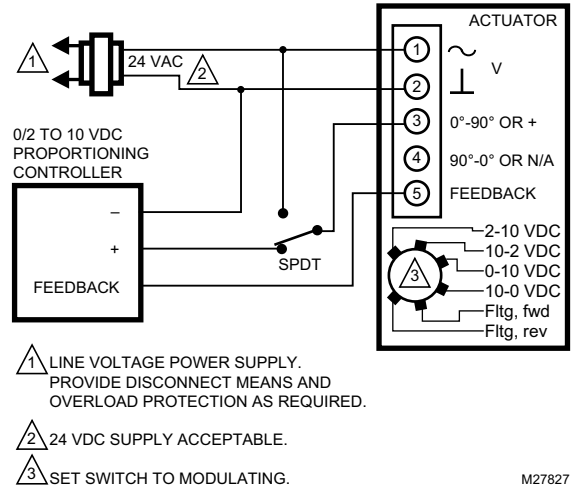

Override to full close

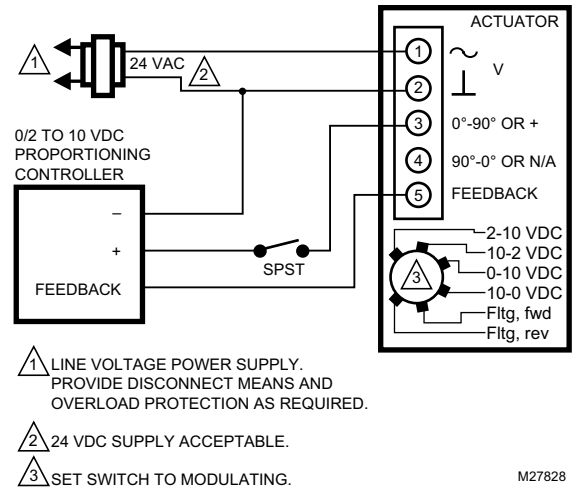

Actuator Wiring Diagrams

Direct Coupled Actuators - Spring Return Models

S10 Series (MS4110, MS7510, MS8110) and S20 Series (MS4120, MS7520, MS8120)

Wiring for On/Off Control

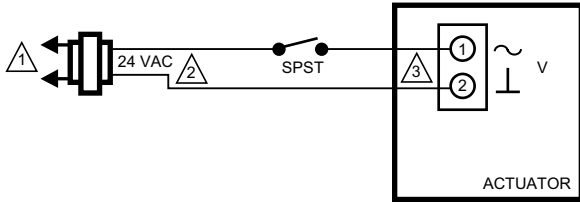

- 1 LINE VOLTAGE POWER SUPPLY. PROVIDE DISCONNECT MEANS AND OVERLOAD PROTECTION AS REQUIRED.
- 2 24 VDC SUPPLY ACCEPTABLE.
- 3 ENSURE PROPER GROUNDING OF ACTUATOR CASE.

M19718C

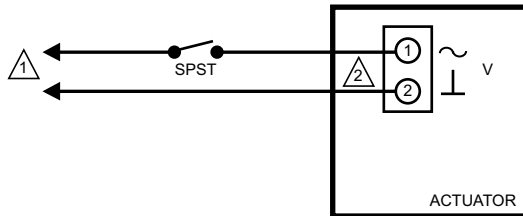

- 1 LINE VOLTAGE POWER SUPPLY. PROVIDE DISCONNECT MEANS AND OVERLOAD PROTECTION AS REQUIRED.
- 2 ENSURE PROPER GROUNDING OF ACTUATOR CASE.

M22289A

Wiring for Floating Control (Floating mode setting)

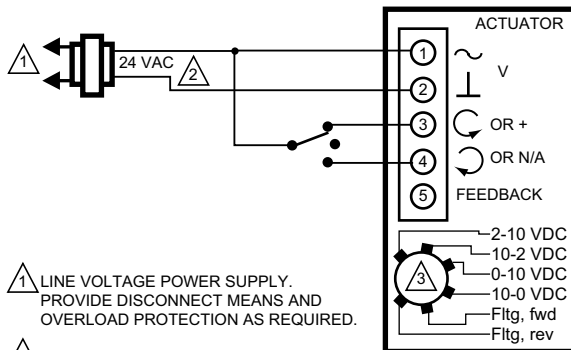

- 1 LINE VOLTAGE POWER SUPPLY. PROVIDE DISCONNECT MEANS AND OVERLOAD PROTECTION AS REQUIRED.
- 2 24 VDC SUPPLY ACCEPTABLE.
- 3 SET SWITCH TO FLOATING.

M19573A

Wiring for Proportioning controllers (Modulating mode setting)

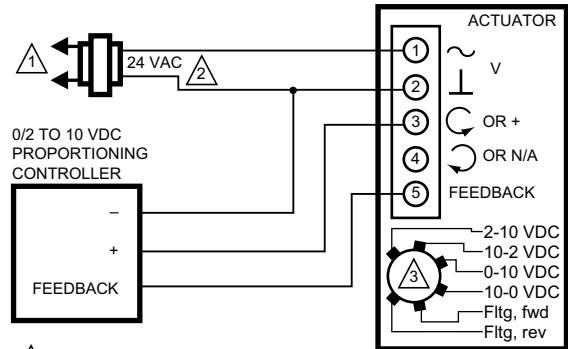

- 1 LINE VOLTAGE POWER SUPPLY. PROVIDE DISCONNECT MEANS AND OVERLOAD PROTECTION AS REQUIRED.
- 2 24 VDC SUPPLY ACCEPTABLE.
- 3 SET SWITCH TO MODULATING.

M19574A

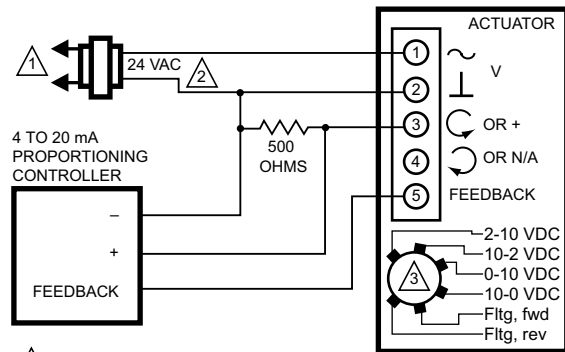

- 1 LINE VOLTAGE POWER SUPPLY. PROVIDE DISCONNECT MEANS AND OVERLOAD PROTECTION AS REQUIRED.
- 2 24 VDC SUPPLY ACCEPTABLE.
- 3 SET SWITCH TO MODULATING.

M22282

Actuator Wiring Diagrams

Direct Coupled Actuators - Spring Return Models

Direct Coupled Actuators - Spring Return Models

Override to full open (Modulating mode setting)

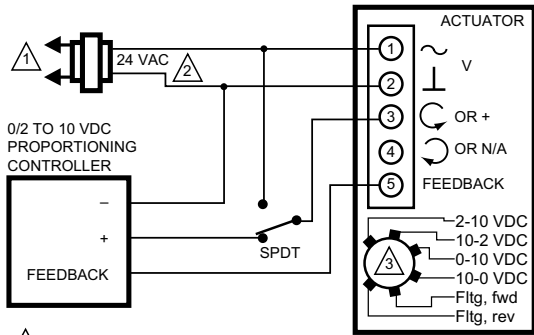

1 LINE VOLTAGE POWER SUPPLY. PROVIDE DISCONNECT MEANS AND OVERLOAD PROTECTION AS REQUIRED.

2 24 VDC SUPPLY ACCEPTABLE.

3 SET SWITCH TO MODULATING.

M19576A

Override to full closed (Modulating mode setting)

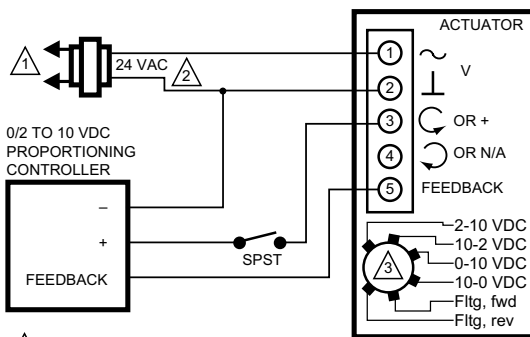

1 LINE VOLTAGE POWER SUPPLY. PROVIDE DISCONNECT MEANS AND OVERLOAD PROTECTION AS REQUIRED.

2 24 VDC SUPPLY ACCEPTABLE.

3 SET SWITCH TO MODULATING.

M19577A

Wiring for Proportioning controllers operating multiple actuators (Modulating mode setting)

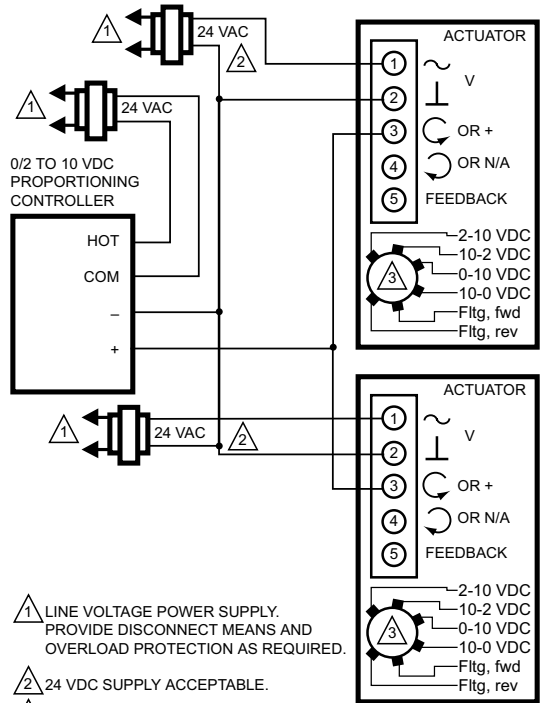

1 LINE VOLTAGE POWER SUPPLY. PROVIDE DISCONNECT MEANS AND OVERLOAD PROTECTION AS REQUIRED.

2 24 VDC SUPPLY ACCEPTABLE.

3 SET SWITCH TO MODULATING.

M22288

Terminal Block Details

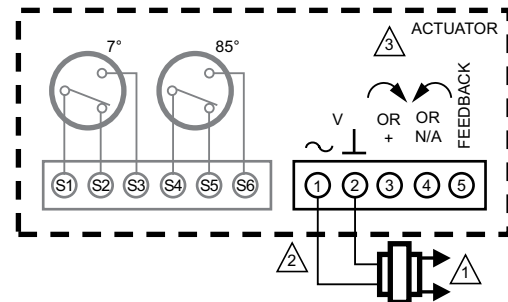

1 POWER SUPPLY. PROVIDE DISCONNECT MEANS AND OVERLOAD PROTECTION AS REQUIRED.

2 THE INTERNAL AUXILIARY SWITCHES MUST BE CONNECTED TO THE SAME POWER SOURCE; OR THE AUXILIARY SWITCHES SHALL BE CONNECTED TO THE SAME POLE OF THE SAME SUPPLY CIRCUIT, CONNECTED IN A SAME POLARITY MANNER.

3 ENSURE PROPER GROUNDING OF ACTUATOR CASE.

M19571B

Actuator Wiring Diagrams

Direct Coupled Actuators - Spring Return Models

ML4125, ML8125, ML4135, and ML8135

Typical 24 Vac wiring

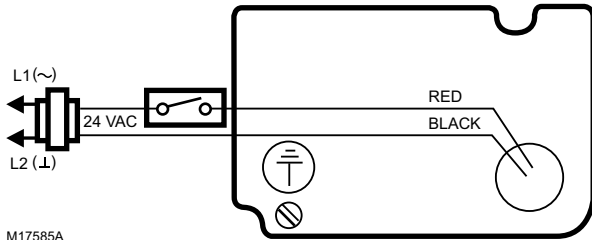

M17585A

Typical 230 Vac Wiring

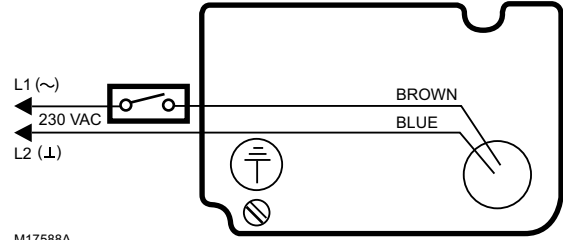

M17588A

Typical 120 Vac Wiring

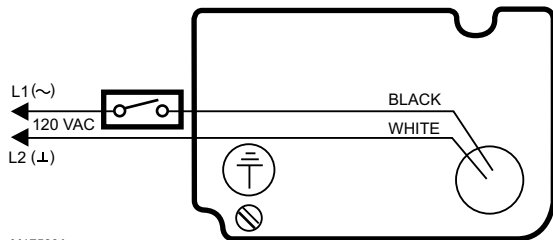

M17589A

Actuator Wiring Diagrams

Direct Coupled Actuators - Non-Spring Return Models

ML6161 and ML7161

ML7161 used with 4-20 mA control

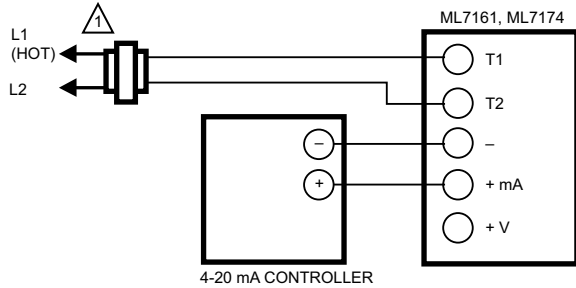

⚠ POWER SUPPLY. PROVIDE DISCONNECT MEANS AND OVERLOAD PROTECTION AS REQUIRED. M18071

ML6174 and ML7174

ML7174 used with 4-20 mA control

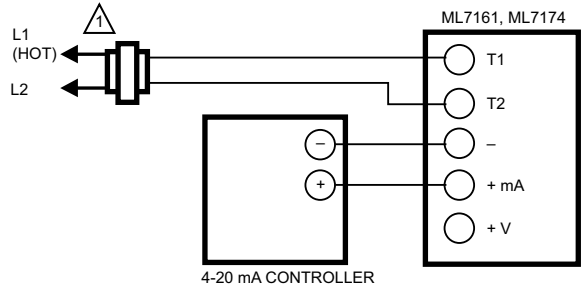

⚠ POWER SUPPLY. PROVIDE DISCONNECT MEANS AND OVERLOAD PROTECTION AS REQUIRED. M18071

ML7161 used with 2-10 Vdc control

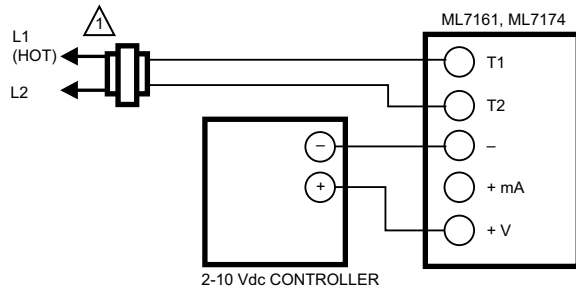

⚠ POWER SUPPLY. PROVIDE DISCONNECT MEANS AND OVERLOAD PROTECTION AS REQUIRED. M18072

ML7174 used with 2-10 Vdc control

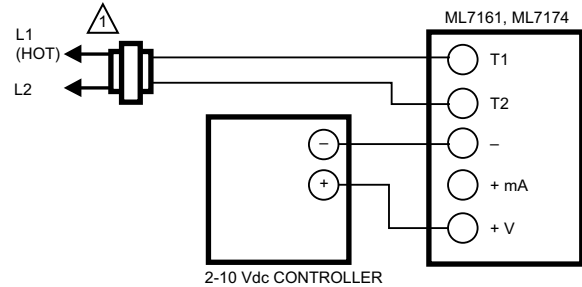

⚠ POWER SUPPLY. PROVIDE DISCONNECT MEANS AND OVERLOAD PROTECTION AS REQUIRED. M18072

Actuator Wiring Diagrams

Direct Coupled Actuators - Non-Spring Return Models

N05 Series (MN6105, MN7505) and N10 Series (MN6110, MN7510)

Wiring for Floating Control

MN6105, MN6110
FLOATING: DIR ↶

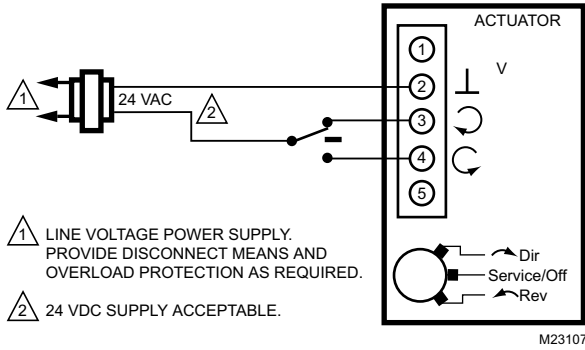

Wiring for Voltage Control

MN7505, MN7510
MODULATING: 0[2]... 10 V, 10... 0[2] V

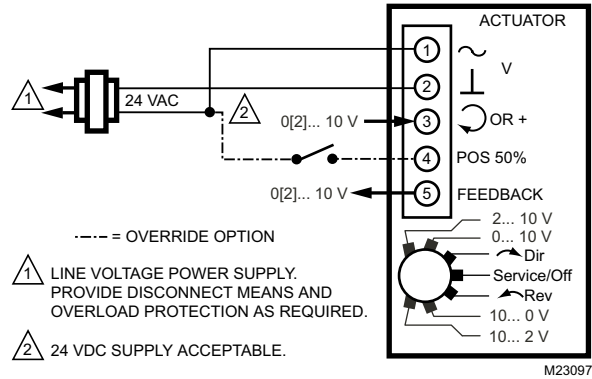

Wiring for Auxiliary Switches

END SWITCHES (CLASS II-ONLY)

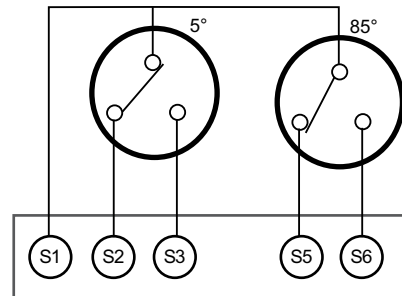

Actuator Wiring Diagrams

Direct Coupled Actuators - Non-Spring Return Models

N20 Series (MN6120, MN7220) and N34 Series (MN6134, MN7234)

Used for On/Off Control

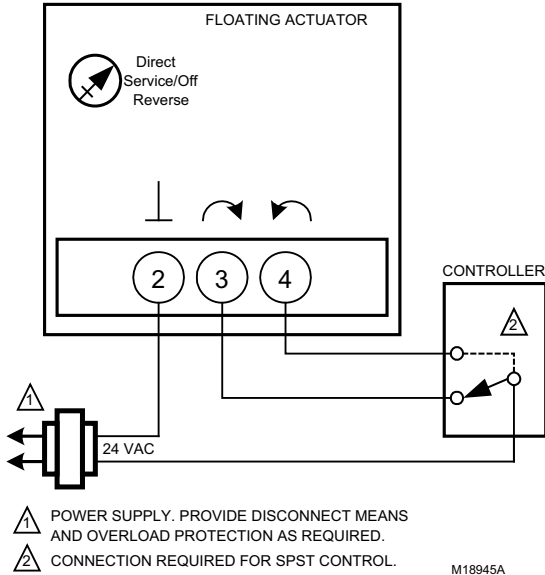

Wiring for Floating Control

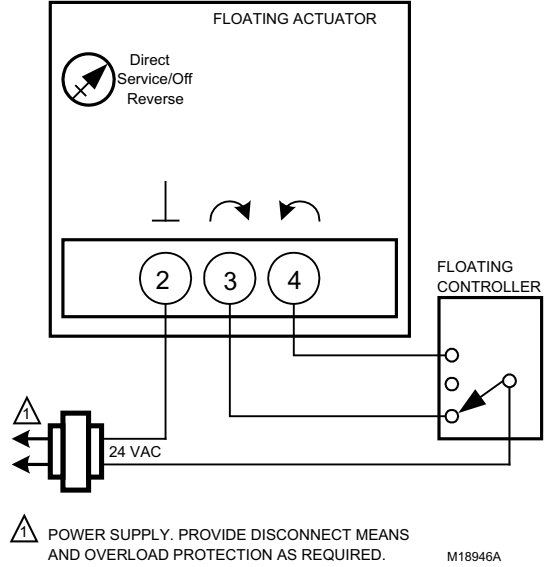

Wiring for Modulating Control

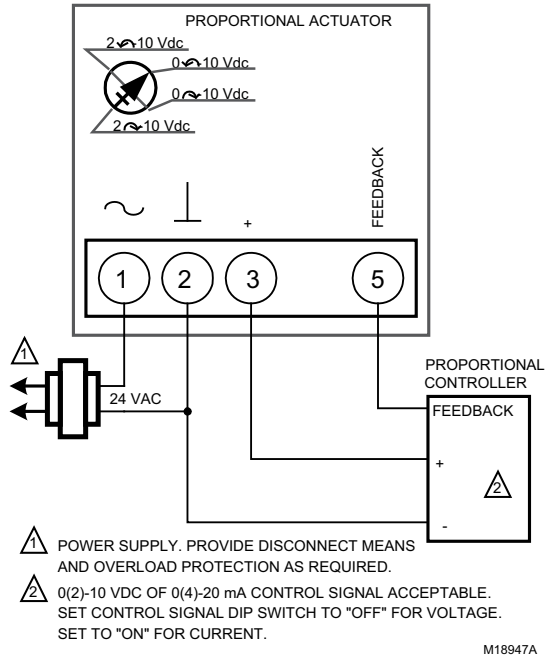

Wiring for Auxiliary Switches

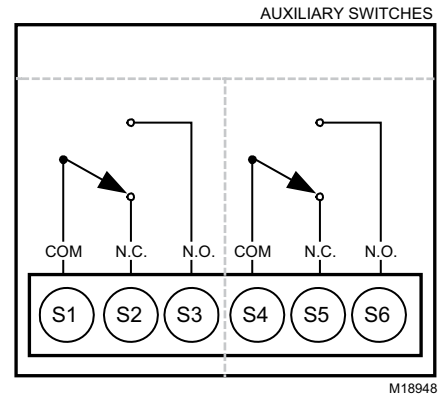

Actuator Wiring Diagrams

Direct Coupled Actuators - Fire and Smoke Actuators

ML4115, ML8115, MS4209F, MS4309F, MS4709F, MS4809F, MS8209F, and MS8309F

Typical 24 Vac wiring

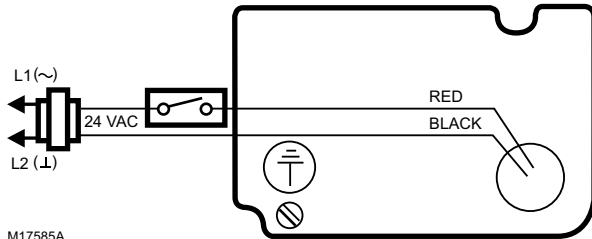

M17585A

Typical 230 Vac Wiring

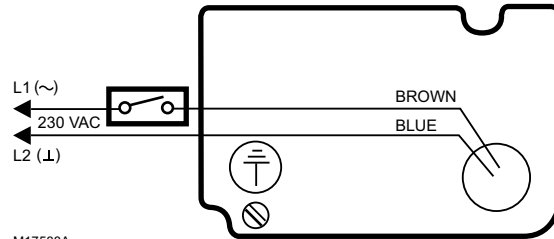

M17588A

Typical 120 Vac wiring

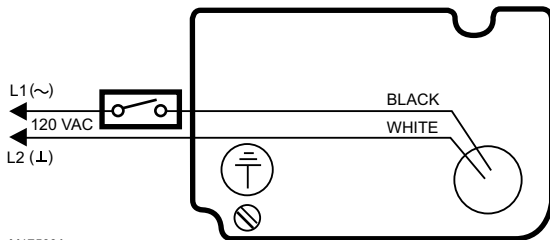

M17589A

MS4120F, MS4620F, and MS8120F

Wiring for 24V Control

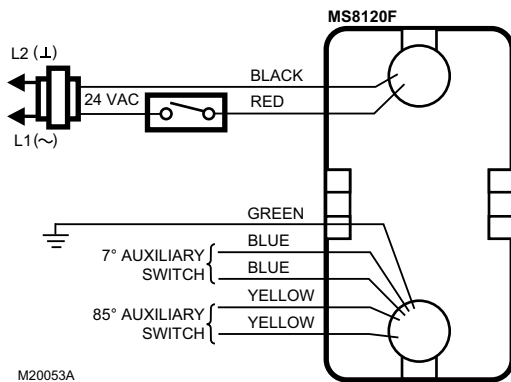

M20053A

Wiring for 120V Control

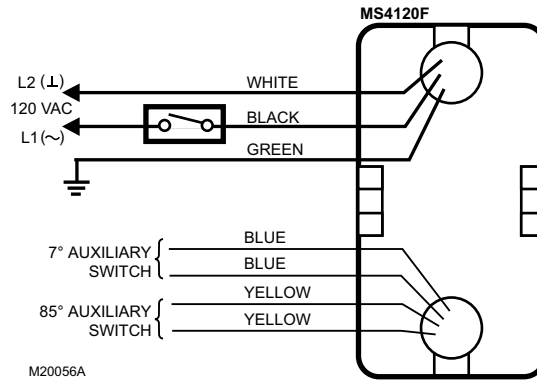

M20056A

Actuator Wiring Diagrams

Foot Mounted Motors

M4185 and M8185

Typical connections for Series 41 motors

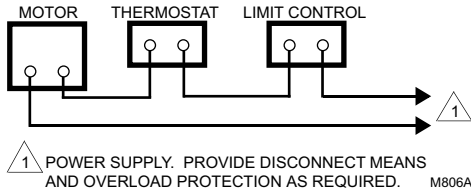

Typical connections for Series 81 motors

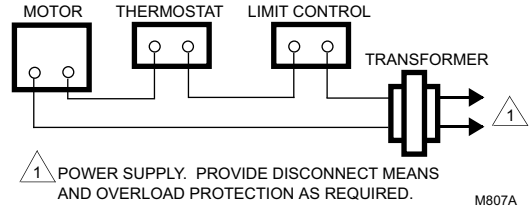

M6184 and M6194

Typical wiring for Series 61 motors

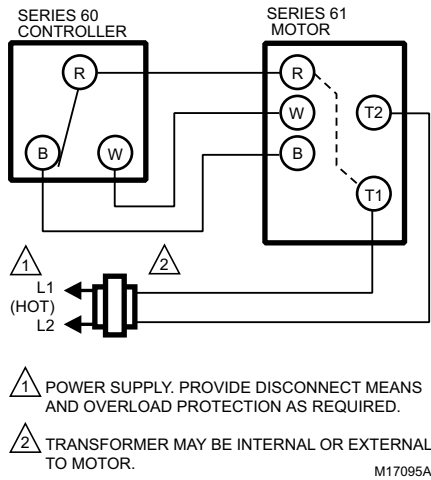

M6284, M6285, and M6294 for slaving applications

Typical wiring for Series 62 motors

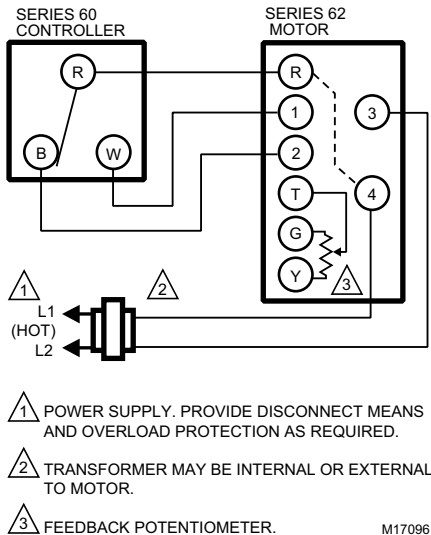

Series 60 and Series 90 motors in slaving application

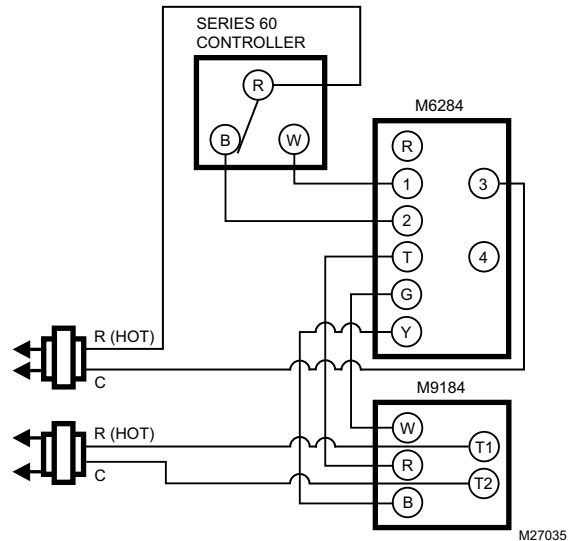

Actuator Wiring Diagrams

Foot Mounted Motors

Foot Mounted Motors

M6274, M6284, M6285, and M6294 Motors with Linear 10K Feedback

Typical wiring for Series 62 motors



- 1 POWER SUPPLY. PROVIDE DISCONNECT MEANS AND OVERLOAD PROTECTION AS REQUIRED.
 - 2 TRANSFORMER MAY BE INTERNAL OR EXTERNAL TO MOTOR.
 - 3 FEEDBACK POTENTIOMETER.
- M17096

M7164, M7284, M7285, M7286, and M7294

Typical wiring for Series 70 motors

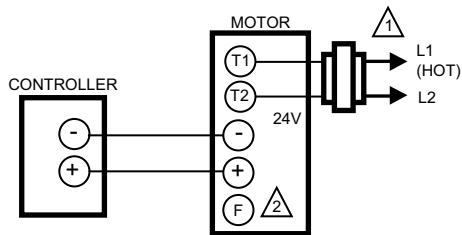

- 1 POWER SUPPLY. PROVIDE DISCONNECT MEANS AND OVERLOAD PROTECTION AS REQUIRED.
 - 2 CONNECTING F TO - WILL DRIVE MOTOR TO FULLY OPEN.
- M5778

M7685

Typical wiring for M7685 motors

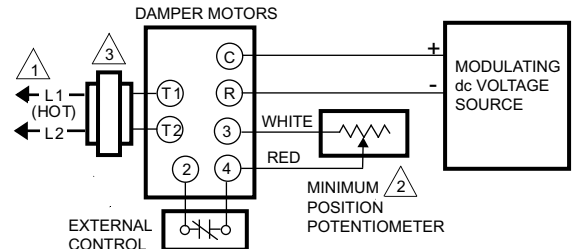

- 1 POWER SUPPLY. PROVIDE DISCONNECT MEANS AND OVERLOAD PROTECTION AS REQUIRED.
 - 2 IF MINIMUM POSITION POTENTIOMETER IS NOT USED, JUMPER TERMINALS 3 AND 4.
 - 3 TRANSFORMER MAY BE INTERNAL OR EXTERNAL.
- M13727

Foot Mounted Motors

M9161, M9164, M9171, M9172, M9174, M9175, M9181, M9182, M9184, M9185, M9186, and M9194

Typical wiring for Series 90 motors

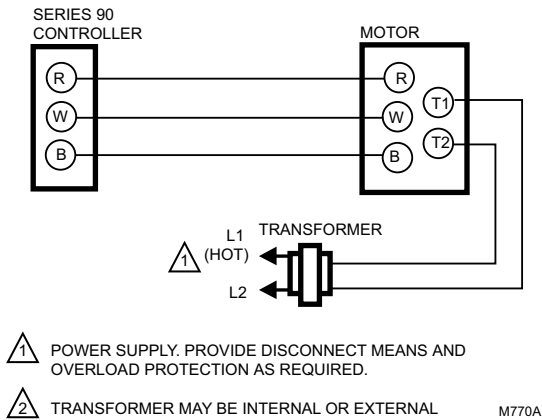

Wiring for Potentiometer Control

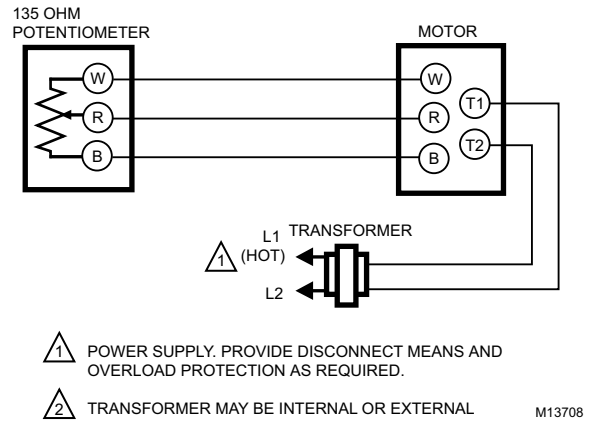

Actuator Wiring Diagrams

Actuators with Butterfly Valves

VFF2, VFF3, and VFF6

Typical Non-Spring Return Floating Control Actuator wiring

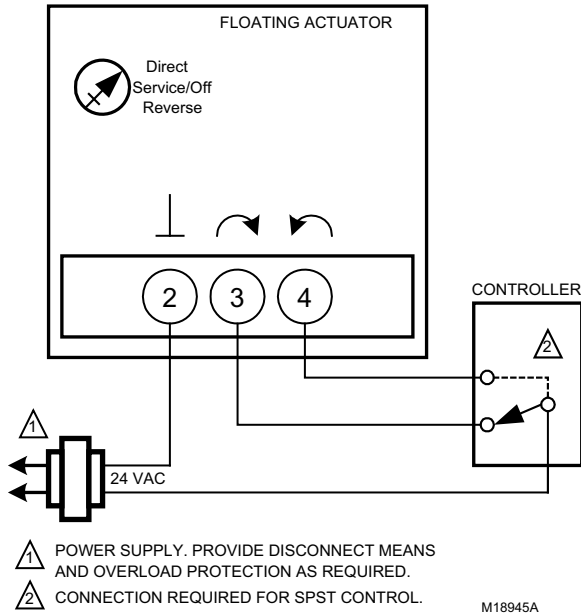

Typical Spring Return Floating/Modulating control wiring

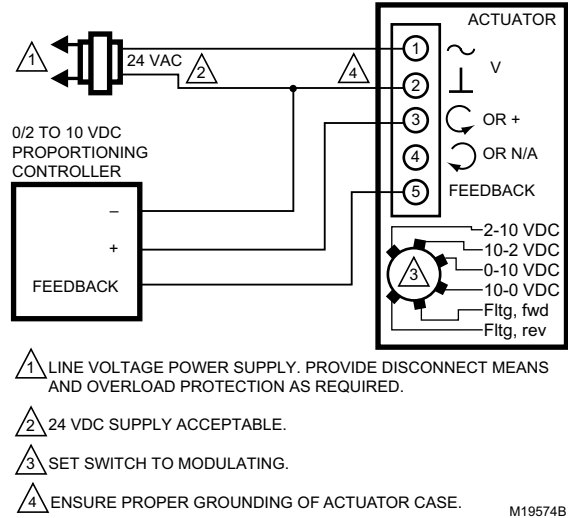

Typical Non-Spring Return 120 Vac Floating control wiring

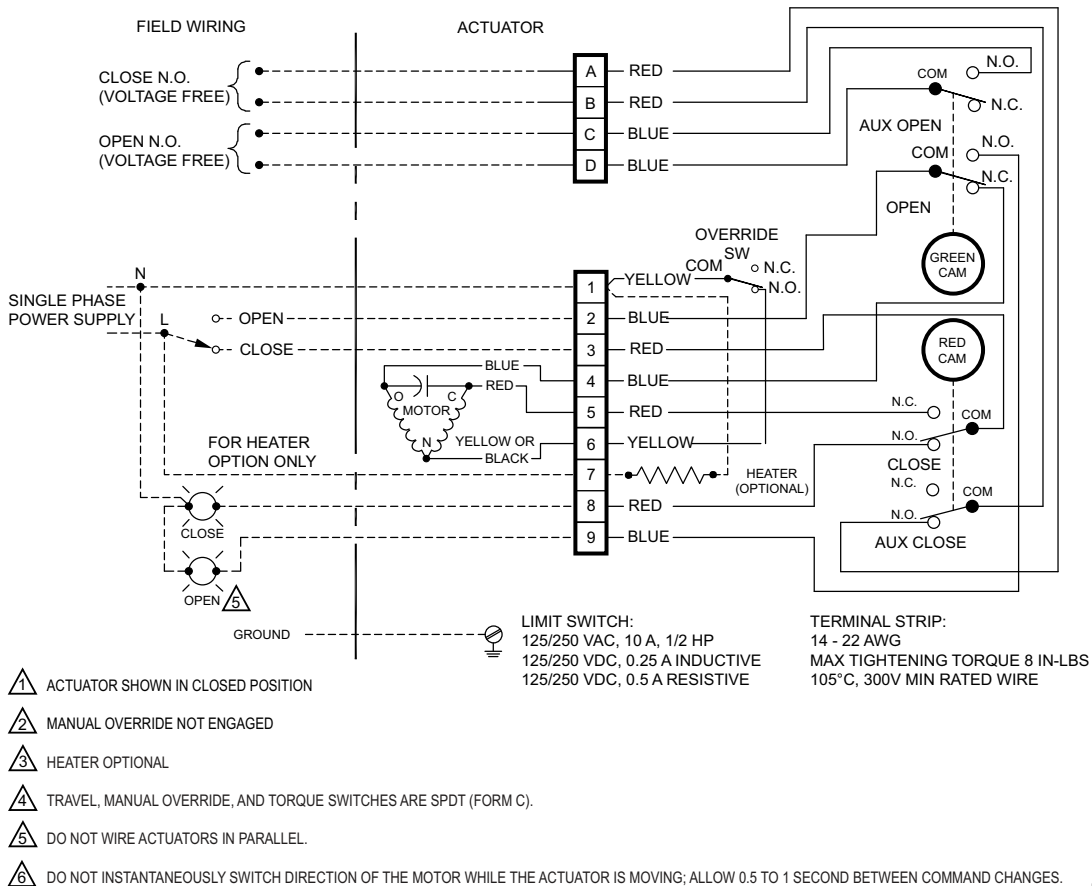

Actuators with Butterfly Valves

Typical Non-Spring Return 120 Vac Floating control wiring

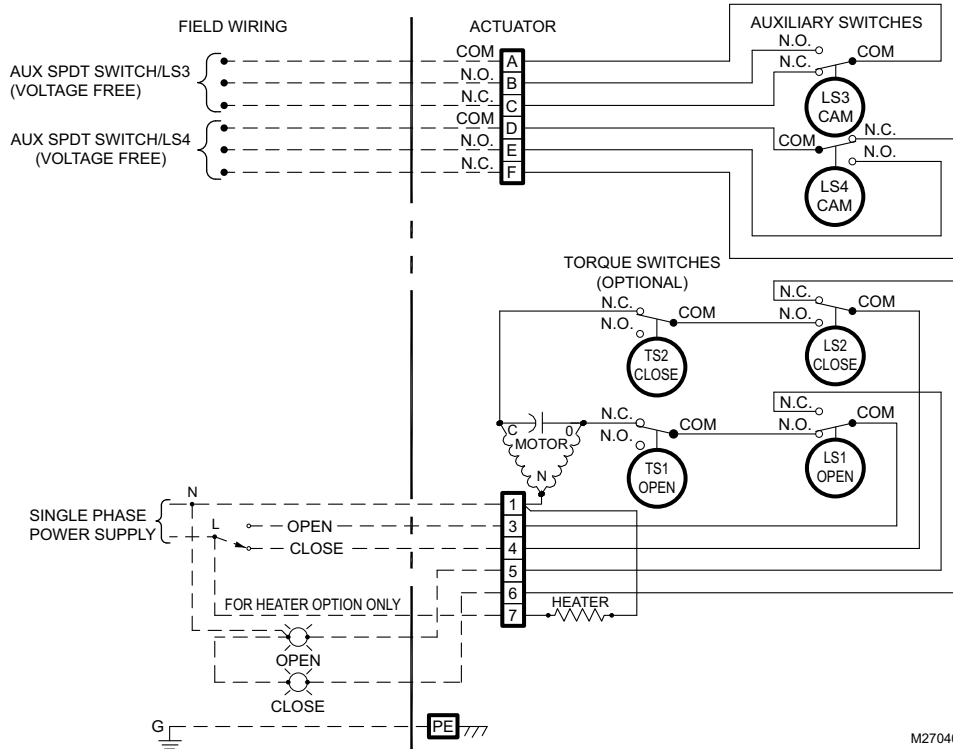

M27040

Typical Non-Spring Return Modulating control wiring

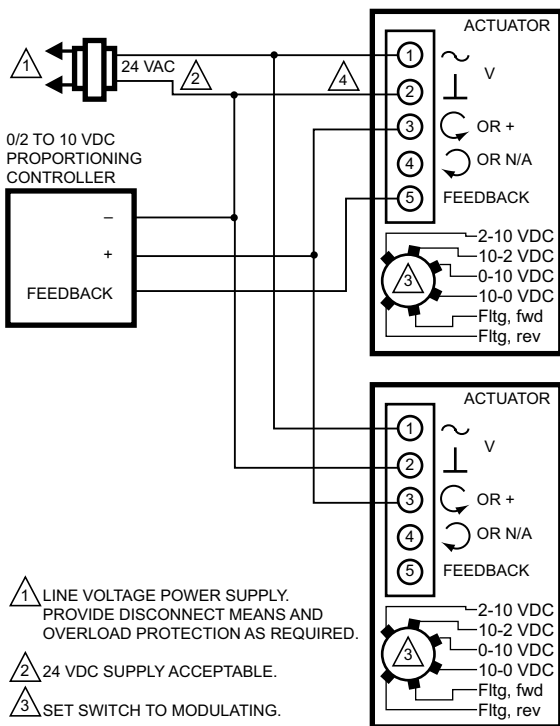

- 1 LINE VOLTAGE POWER SUPPLY. PROVIDE DISCONNECT MEANS AND OVERLOAD PROTECTION AS REQUIRED.
- 2 24 VDC SUPPLY ACCEPTABLE.
- 3 SET SWITCH TO MODULATING.
- 4 ENSURE PROPER GROUNDING OF ACTUATOR CASE.

M19575B

Typical Spring Return 2-Position, 24 Vac wiring

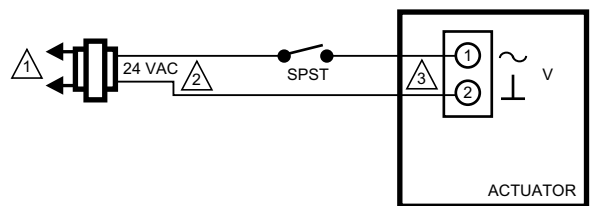

- 1 LINE VOLTAGE POWER SUPPLY. PROVIDE DISCONNECT MEANS AND OVERLOAD PROTECTION AS REQUIRED.
- 2 24 VDC SUPPLY ACCEPTABLE.
- 3 ENSURE PROPER GROUNDING OF ACTUATOR CASE.

M19718C

Section 5: Guide Specifications

Guide Specifications 170

Threaded Globe Valves

23 00 00 HEATING, VENTILATING, AND AIR-CONDITIONING (HVAC)

23 09 00 Instrumentation and Control for HVAC

23 09 13 Instrumentation and Control Devices for HVAC

23 09 13.33 Control Valves

Threaded Globe Valves

Mounting

1. Two-way threaded globe valves shall be red brass with female national pipe thread fittings in sizes from ½ up to 3 inches (DN15 to DN80). Three-way valves shall be up to 2 inches (DN50).
2. Valves sized ½ inch (DN15) shall be available in multiple Cv ratings. Cv ratings shall be a geometric progression.
3. Valves shall offer equal percentage control characteristic on the A port. Valves rated for high pressure steam shall have linear control characteristic.
4. Two-way, direct acting valves up to 2 inches (DN50) shall have stainless steel seats. Valves rated for high pressure steam shall have stainless steel plug.
5. Two-way, direct acting valves 2 ½ to 3 inches shall have Teflon or carbon-loaded Teflon discs for water or steam service and brass seats.
6. Three-way and reverse-acting two way valves shall be constructed with brass plugs and seats.
7. Three-way valves shall feature A-B-AB porting for mixing control. Flow capacity of the B port shall have a linear flow characteristic and be reduced 20% to approximate constant loop flow in coil-bypass applications.
8. Bronze valves bodies shall have static pressure ratings ANSI/ASME Class 150, maximum temperature 337°F (169 C).
9. Valve stroke shall be ¾ inch (20 mm) for precise control.
10. Undercut bonnet of 1 3/8 inch (35 mm) diameter shall allow linkage or direct-coupled actuator attachment by U-bolt, twin set screws, or mating clamp.
11. Valves shall carry Canadian Registration Numbers.

Control

1. Actuation shall be electric or pneumatic. Actuators may be direct-coupled linear operators, or rotary actuators attached by means of a linkage. A dual tandem linkage for rotary actuators will provide enhanced close-off ratings.
2. Electric actuators shall provide two-position, floating, or proportional control. Proportional control refers to direct acceptance of 0-10 Vdc, 2-10 Vdc or, with addition of a 500 ohm resistor, a 4-20 mA input signal. Floating control refers to direct acceptance of 24 Vac pulse-width modulated open and close commands from a tri-state (SP3T) controller. Two-position control of non-fail safe actuators shall be in the form of 24 Vac power controlled by SPDT switch. Two-position control of fail safe actuators shall be in the form of 24 Vac power controlled by SPST switch.
3. Globe valves shall have minimum 50:1 rangeability with an equal percentage flow characteristic for water or linear flow characteristic for steam.

Other

1. Valves shall have spring-loaded, self-adjusting, Teflon® packing.
2. All valves must be field serviceable without the need to remove the valve from the piping, in order to minimize future service costs.
3. Valves may not be installed with stems below the horizontal plane to prevent actuator damage due to stem seal leakage, or accumulation of particulate in the stem packing.
4. Valves controlling steam should be installed with the actuator beside the valve, not above it.
5. Operating pressure of high pressure steam-rated valves shall not exceed 100 psig (690 kPa). Superheated steam must not exceed the temperature rating of the valve.
6. A water filtration and treatment system shall be installed and operated according to the requirements of Division 23 25 13, Water Treatment for Closed-Loop Hydronic Systems. The presence of excess rust in the system will void the manufacturer's warranty.
7. Actuated valves shall be capable of closing off against their maximum operating differential pressure. Seat leakage when closed shall be ANSI/ASME Class III, 0.05% maximum. Seat leakage for valve with Teflon-based discs shall be 0.5% maximum.
8. Differential pressure for quiet operation shall be at least 20 psid (138 kPa).
9. All valves and actuators shall be manufactured under ISO 9001 International Quality Control Standards.
10. Valves and actuators shall be as manufactured by Honeywell.

Pressure-Balanced Flanged Globe Valves

23 00 00 HEATING, VENTILATING, AND AIR-CONDITIONING (HVAC)

23 09 00 Instrumentation and Control for HVAC

23 09 13 Instrumentation and Control Devices for HVAC

23 09 13.33 Control Valves

Pressure-Balanced Flanged Globe Valves

Mounting

1. Flanged globe valves shall be cast iron with ANSI/ASME 125 flanges in sizes from 2 ½ up to 6 inches (DN65 to DN150), maximum temperature 353°F (178 C).
2. Valve dimensions will conform to ANSI/ISA S75.03.
3. Cv ratings shall be a geometric progression.
4. Valves shall offer equal percentage or linear control characteristic.
5. Valves shall have stainless steel stem, plug and seats.
6. Valve stroke, sizes 2 ½ and 3 inches (DN65-80), shall be ¾ inch (20 mm) for precise control. Undercut bonnet of 1 3/8 inch (35 mm) diameter shall allow linkage or direct-coupled actuator attachment by U-bolt, twin set screws, or mating clamp.
7. Valve stroke, sizes 4 to 6 inches (DN100-150), shall be 1 ½ inch (38 mm) for precise control. Undercut bonnet of 1 7/8 inch (48 mm) diameter shall allow linkage or direct-coupled actuator attachment by U-bolt, twin set screws, or mating clamp.

Control

1. Actuation shall be electric or pneumatic. Actuators may be direct-coupled linear operators, or rotary actuators attached by means of a linkage. A dual tandem linkage for rotary actuators will provide enhanced close-off ratings.
2. Electric actuators shall provide two-position, floating, or proportional control. Proportional control refers to direct acceptance of 0-10 Vdc, 2-10 Vdc or, with addition of a 500 ohm resistor, a 4-20 mA input signal. Floating control refers to direct acceptance of 24 Vac pulse-width modulated open and close commands from a tri-state (SP3T) controller. Two-position control of non-fail safe actuators shall be in the form of 24 Vac power controlled by SPDT switch. Two-position control of fail safe actuators shall be in the form of 24 Vac power controlled by SPST switch.
3. Globe valves shall have minimum 50:1 rangeability with an equal percentage flow characteristic for water or linear flow characteristic for steam or chilled water control.

Other

1. Valves shall have spring-loaded, self-adjusting, Teflon® packing.
2. All valves must be field serviceable without the need to remove the valve from the piping, in order to minimize future service costs.
3. Valves may not be installed with stems below the horizontal plane to prevent actuator damage due to stem seal leakage, or accumulation of particulate in the stem packing.
4. Valves controlling steam should be installed with the actuator beside the valve, not above it.
5. Operating pressure of high pressure steam-rated valves shall not exceed 125 psig (860 kPa). Superheated steam must not exceed the temperature rating of the valve.
6. A water filtration and treatment system shall be installed and operated according to the requirements of Division 23 25 13, Water Treatment for Closed-Loop Hydronic Systems. The presence of excess rust in the system will void the manufacturer's warranty.
7. Actuated valves shall be capable of closing off against 175 psid (1200 kPa). Seat leakage when closed shall be ANSI/ASME Class IV, 0.01% maximum.
8. Differential pressure for quiet operation shall be at least 20 psid (138 kPa).
9. All valves and actuators shall be manufactured under ISO 9001 International Quality Control Standards.
10. Valves and actuators shall be as manufactured by Honeywell.

Guide Specifications

Flanged Globe Valves

23 00 00 HEATING, VENTILATING, AND AIR-CONDITIONING (HVAC)

23 09 00 Instrumentation and Control for HVAC

23 09 13 Instrumentation and Control Devices for HVAC

23 09 13.33 Control Valves

Flanged Globe Valves

Mounting

1. Flanged globe valves shall be cast iron with ANSI/ASME 125 and ANSI/ASME250 flanges in sizes from 2 ½ up to 6 inches (DN65 to DN150), maximum temperature 353°F (178 C).
2. Valve dimensions will conform to ANSI/ISA S75.03.
3. Cv ratings shall be a geometric progression.
4. Valves shall offer equal percentage or linear control characteristic on the A port. Valves rated for high pressure steam shall have linear control characteristic.
5. Two-way and diverting valves shall have stainless steel stem, plug and seats. Mixing valves shall have seats integral to the body.
6. Three-way valves shall feature A-B-AB porting for mixing or diverting control. The B port shall have a linear flow characteristic.
7. Valve stroke, sizes 2 ½ and 3 inches (DN65-80), shall be ¾ inch (20 mm) for precise control. Undercut bonnet of 1 3/8 inch (35 mm) diameter shall allow linkage or direct-coupled actuator attachment by U-bolt, twin set screws, or mating clamp.
8. Valve stroke, sizes 4 to 6 inches (DN100-150), shall be 1 ½ inch (38 mm) for precise control. Undercut bonnet of 1 7/8 inch (48 mm) diameter shall allow linkage or direct-coupled actuator attachment by U-bolt, twin set screws, or mating clamp.

Control

1. Actuation shall be electric or pneumatic. Actuators may be direct-coupled linear operators, or rotary actuators attached by means of a linkage. A dual tandem linkage for rotary actuators will provide enhanced close-off ratings.
2. Electric actuators shall provide two-position, floating, or proportional control. Proportional control refers to direct acceptance of 0-10 Vdc, 2-10 Vdc or, with addition of a 500 ohm resistor, a 4-20 mA input signal. Floating control refers to direct acceptance of 24 Vac pulse-width modulated open and close commands from a tri-state (SP3T) controller. Two-position control of non-fail safe actuators shall be in the form of 24 Vac power controlled by SPDT switch. Two-position control of fail safe actuators shall be in the form of 24 Vac power controlled by SPST switch.
3. Globe valves shall have minimum 50:1 rangeability with an equal percentage flow characteristic for water or linear flow characteristic for steam, chilled water, or diverting control.

Other

1. Valves shall have spring-loaded, self-adjusting, Teflon® packing.
2. All valves must be field serviceable without the need to remove the valve from the piping, in order to minimize future service costs.
3. Valves may not be installed with stems below the horizontal plane to prevent actuator damage due to stem seal leakage, or accumulation of particulate in the stem packing.
4. Valves controlling steam should be installed with the actuator beside the valve, not above it.
5. Operating pressure of high pressure steam-rated valves shall not exceed 125 psig (860 kPa). Superheated steam must not exceed the temperature rating of the valve.
6. A water filtration and treatment system shall be installed and operated according to the requirements of Division 23 25 13, Water Treatment for Closed-Loop Hydronic Systems. The presence of excess rust in the system will void the manufacturer's warranty.
7. Actuated valves shall be capable of closing off against their maximum operating differential pressure. Seat leakage when closed shall be ANSI/ASME Class III, 0.05% maximum.
8. Mixing valve shall rely on hydraulic pressure differences to control flow. A-port seat leakage for mixing valve shall be 0.5% maximum, 1% maximum on B port.
9. Differential pressure for quiet operation shall be at least 20 psid (138 kPa).
10. All valves and actuators shall be manufactured under ISO 9001 International Quality Control Standards.
11. Valves and actuators shall be as manufactured by Honeywell.

Threaded Control Ball Valves and Actuators

23 00 00 HEATING, VENTILATING, AND AIR-CONDITIONING (HVAC)

23 09 00 Instrumentation and Control for HVAC

23 09 13 Instrumentation and Control Devices for HVAC

23 09 13.33 Control Valves

Threaded Control Ball Valves and Actuators

Mounting and Wiring

1. Valves shall be forged brass with female national pipe thread pipe fittings from ½ to 2 ½ inches (DN15 to DN65), and 3 inches (DN80) in two-way.
2. Valves shall provide modified equal percentage, or equal percentage flow control characteristics.
3. Valve ball and stem construction shall be nickel-plated brass. Stainless steel trim shall be optional on 2-way valves.
4. Valve shall have a blow-out proof stem with Teflon® trust bearings, EPDM O-ring, and silicon grease to prevent leakage.
5. Three-way valves shall be used for mixing or diverting control and provide A-B-AB port orientations in a "T" pattern with bottom B port. The Bypass port shall provide 20% reduced Cv rating using a linear flow characteristic to approximate constant flow through branch circuits.
6. Threaded valve bodies shall have maximum static pressure rating of 360 psig (2500 kPa) at 250°F (120 C).
7. Actuators shall be direct coupled rotary type requiring neither crank-arm nor linkage and direct mount to the valve actuator bracket. The bracket shall provide for up to 2 inches (50 mm) of pipe insulation.
8. Actuators shall provide internal wiring terminal connections with threaded holes for flexible conduit strain relief fittings where mechanical protection is required by local codes.
9. Valve actuator shall be capable of operating on 24 Vac Class II power (Safety Extra-Low Voltage), or be UL Recognized or CSA Certified to U.S. and Canadian Standards for use with line voltage.

Control

1. The actuator shall provide two-position, floating, or modulating control. Modulating control refers to direct acceptance of 2-10 Vdc or, with addition of a 500 ohm resistor, a 4-20 mA input signal. Floating control refers to direct acceptance of 24 Vac pulse-width modulated open and close commands from a tri-state (SP3T) controller. Two-position control of non-fail safe actuators shall be in the form of 24 Vac power controlled by SPDT switch. Two-position control of fail safe actuators shall be in the form of 24 Vac power controlled by SPST switch.
2. Threaded control ball valves shall have minimum 50:1 rangeability with an equal percentage flow characteristic provided using a laser-cut flow control insert within the ball. The insert shall not make contact with valve seals and seats.
3. Multiple Cv ratings will be available in each valve size.
4. Modulating control models shall provide a 2-10 Vdc feedback signal.
5. Modulating actuators shall have a rotation direction control switch accessible on the cover to change between modulating or floating control.
6. Actuators shall have SPST or SPDT switch for position verification feedback as an available option.
7. Actuation will be available with fail-safe operation.

Other

1. Valve stems must be field serviceable.
2. Valves may not be installed with stems below the horizontal plane to prevent actuator damage due to stem seal leakage, or accumulation of particulate in the stem packing.
3. A water filtration and treatment system shall be installed and operated according to the requirements of Division 23 25 13, Water Treatment for Closed-Loop Hydronic Systems. The presence of excess rust in the system will void the manufacturer's warranty.
4. Actuated valves shall be capable of closing off against their maximum operating differential pressure. Seat leakage of the A port when closed shall be ANSI/ASME Class IV, 0.01% maximum.
5. All spring return actuators must be designed for either normally open or normally closed fail-safe operation with a continuously engaged mechanical return spring. This spring must return the actuator to a fail-safe position within 20-25 seconds of power loss.
6. All spring return actuators must be able to spring return from -40°F to 189°F
7. All actuators shall be designed for a minimum of 60,000 full-stroke cycles at actuator rated torque and temperature, and 1,500,000 repositions.
8. Run time shall be constant and independent of: load, temperature, and supply voltage (within specifications).
9. All valves and actuators shall be manufactured under ISO 9001 International Quality Control Standards.
10. Actuators shall have a five year warranty.
11. Valves and actuators shall be as manufactured by Honeywell.

Control Ball Valves and Actuators

23 00 00 HEATING, VENTILATING, AND AIR-CONDITIONING (HVAC)

23 09 00 Instrumentation and Control for HVAC

23 09 13 Instrumentation and Control Devices for HVAC

23 09 13.33 Control Valves

Control Ball Valves and Actuators

Mounting and Wiring

1. Valves shall be cast iron with ANSI/ASME 125 flange fittings from 4 to 6 inches (DN100 to DN150).
2. Valves shall provide equal percentage flow control characteristics. Valve ball and stem construction shall be stainless steel.
3. Valve shall have a blow-out proof stem.
4. Three-way valves shall be used for mixing control and provide A-B-AB port orientations in a "T" pattern with side B port. The Bypass port shall provide 20% reduced Cv rating using a linear flow characteristic to approach constant flow through branch circuits.
5. Threaded valve bodies shall have maximum static pressure rating of 240 psig (1650 kPa) at 250°F (120 C).
6. Actuators shall be direct coupled rotary type requiring neither crank-arm nor linkage and direct mount to the valve actuator bracket. The bracket shall provide for up to 2 inches (50 mm) of pipe insulation.
7. Actuators shall provide internal wiring terminal connections with threaded holes for flexible conduit strain relief fittings where mechanical protection is required by local codes.
8. Valve actuator shall be capable of operating on 24 Vac Class II power, or be UL Recognized or CSA Certified to U.S. and Canadian Standards for use with line voltage.

Control

1. The actuator shall provide two-position, floating, or modulating control. Modulating control refers to direct acceptance of 2-10 Vdc or, with addition of a 500 ohm resistor, a 4-20 mA input signal. Floating control refers to direct acceptance of 24 Vac pulse-width modulated open and close commands from a tri-state (SP3T) controller. Two-position control of non-fail safe actuators shall be in the form of 24 Vac power controlled by SPDT switch. Two-position control of fail safe actuators shall be in the form of 24 Vac power controlled by SPST switch.
2. Flanged control ball valves shall have minimum 100:1 rangeability with an equal percentage flow characteristic provided by a laser-milled stainless steel ball.
3. Multiple Cv ratings will be available in each valve size.
4. Modulating control models provide a 2-10 Vdc feedback signal.
5. Proportional actuators shall have a rotation direction control switch accessible on the cover to change between proportional or floating control.
6. Actuators shall have SPST or SPDT switch for position verification feedback as an available option.
7. Actuation will be available with fail-safe operation.

Other

1. Valve stems must be field serviceable.
2. Valves may not be installed with stems below the horizontal plane to prevent actuator damage due to stem seal leakage, or accumulation of particulate in the stem packing.
3. A water filtration and treatment system shall be installed and operated according to the requirements of Division 23 25 13, Water Treatment for Closed-Loop Hydronic Systems. The presence of excess rust in the system will void the manufacturer's warranty.
4. Actuated valves shall be capable of closing off against their maximum operating differential pressure. Seat leakage of the A port when closed shall be ANSI/ASME Class IV, 0.01% maximum.
5. All spring return actuators must be designed for either normally open or normally closed fail-safe operation with a continuously engaged mechanical return spring. This spring must return the actuator to a fail-safe position within 20-25 seconds of power loss.
6. All 10 and 20 Nm spring return actuators must be able to spring return from -40°F to 189°F
7. All actuators shall be designed for a minimum of 60,000 full-stroke cycles at actuator rated torque and temperature, and 1,500,000 repositions.
8. Run time shall be constant and independent of: load, temperature, and supply voltage (within specifications).
9. All valves and actuators shall be manufactured under ISO 9001 International Quality Control Standards.
10. Actuators shall have a five year warranty.
11. Valves and actuators shall be as manufactured by Honeywell.

Flanged Butterfly Valves and Actuators

23 00 00 HEATING, VENTILATING, AND AIR-CONDITIONING (HVAC)

23 09 00 Instrumentation and Control for HVAC

23 09 13 Instrumentation and Control Devices for HVAC

23 09 13.33 Control Valves

Flanged Butterfly Valves and Actuators

Mounting and Wiring

1. Valves shall be cast iron with ANSI/ASME 125 flange fittings from 2 to 20 inches (DN50 to DN500). Valve body shall be coated with polymer resin for corrosion protection.
2. Valves shall provide equal percentage flow control characteristics up to 60° disk rotation.
3. Valve disk construction shall be Nylon 11-coated cast iron. Valve seat shall be peroxide-cured EPDM combination seat and flange gasket. Valve stem shall be blow-out proof stainless steel.
4. Three-way valve assemblies with cast iron pipe T's shall be used for mixing or diverting control and provide either A-B-AB or A-AB-B port orientations in a "T" pattern with side port.
5. Valve bodies shall have maximum static pressure rating of 250 psig (1700 kPa) at 250°F (120 C).
6. Actuators shall be direct coupled rotary type requiring neither crank-arm nor linkage with 2-way valve bodies, and direct mount to the valve actuator bracket. The bracket shall provide for up to 2 inches (50 mm) of pipe insulation.
7. Actuators shall provide internal wiring terminal connections with threaded holes for flexible conduit strain relief fittings for line voltage wiring or where mechanical protection is required by local codes.
8. Valve actuator shall be capable of operating on 24 Vac Class II power (Safety Extra-Low Voltage), or be UL Recognized or CSA Certified to U.S. and Canadian Standards for use with line voltage.

Control

1. Electric actuators shall provide two-position, floating, or modulating control. Modulating control refers to direct acceptance of 2-10 Vdc or, with addition of a 500 ohm resistor, a 4-20 mA input signal. Floating control refers to direct acceptance of 24 or 120 Vac pulse-width modulated open and close commands from a tri-state (SP3T) controller. Two-position control of non-fail safe actuators shall be in the form of 24 or 120 Vac power controlled by SPDT switch. Two-position control of fail safe actuators shall be in the form of 24 or 120 Vac power controlled by SPST switch.
2. High pressure pneumatic actuators shall be rack-and-pinion design, with or without spring return and provide two-position or proportional control by means of air pressure, electric solenoids, pneumatic positioner, or electro-pneumatic servo controllers.
3. Industrial grade direct-drive actuators shall have polymer-coated, water-tight enclosures rated NEMA 4.
4. Modulating actuators shall provide a 2-10 Vdc feedback signal.
5. Proportional non-industrial grade actuators shall have a rotation direction control switch accessible on the cover to change between proportional or floating control.
6. Actuators shall have SPST or SPDT auxiliary switch for position verification as an available option.
7. Actuation will be available with fail-safe operation.

Other

1. Valves may not be installed with stems below the horizontal plane to prevent actuator damage due to stem seal leakage, or accumulation of particulate in the stem packing.
2. A water filtration and treatment system shall be installed and operated according to the requirements of Division 23 25 13, Water Treatment for Closed-Loop Hydronic Systems. The presence of excess rust in the system will void the manufacturer's warranty.
3. Under-cut disks shall provide 50 psid (345 kPa) close-off. Full cut disks shall provide 150 psid (1034 kPa) minimum close-off. Seat leakage when closed shall be ANSI/ASME Class IV, maximum 0.01%.
4. All spring return actuators must be designed for either normally open or normally closed fail-safe operation with a continuously engaged mechanical return spring. This spring must return the actuator to a fail-safe position within 20-25 seconds of power loss.
5. Run time shall be constant and independent of: load, temperature, and supply voltage (within specifications).
6. All valves and actuators shall be manufactured under ISO 9001 International Quality Control Standards.

Fan Coil Zone Valves and Dedicated Actuators

23 00 00 HEATING, VENTILATING, AND AIR-CONDITIONING (HVAC)

23 09 00 Instrumentation and Control for HVAC

23 09 13 Instrumentation and Control Devices for HVAC

23 09 13.33 Control Valves

Fan Coil Zone Valves and Dedicated Actuators

Mounting and Wiring

1. Valves shall be forged brass with sweat or female national pipe thread pipe fittings in sizes from ½ up to 1 inches (DN15 to DN25). Inverted flare pipe fittings shall be available for ½ inch (DN15) size, with sweat adapters for larger pipe sizes.
2. Valves shall be compact size capable of fitting inside terminal equipment such as fan coil units or unit ventilators.
3. Valves shall provide quick open flow control characteristics. Valve plug shall be rotating ball-plug style with brass seat construction.
4. Three-way valves shall have A-AB-B porting and be used for mixing control in coil-bypass applications.
5. Valves bodies shall have static pressure ratings of 300 psig (2000 kPa) at 200°F (93 C) minimum.
6. Actuators shall be direct coupled type requiring neither crank-arm nor linkage and direct mount to the associated Honeywell valve family using a snap-on engagement, and be removable without the use of tools.
7. Actuators shall provide lead wire connections with knock-out for ½ inch nominal flexible conduit where mechanical protection is required by local codes.
8. Valve actuator shall be capable of operating on 24 Vac Class II power, or be UL Recognized or CSA Certified to U.S. and Canadian Standards for use with line voltage.

Control

1. The actuator shall provide two-position control with spring return controlled by SPST switch.
2. Actuators shall have SPST pilot-duty auxiliary switch for position verification feedback as an available option.
3. Actuators will be standard with fail-safe operation.

Other

1. All valves must be field serviceable without the need to remove the valve from the piping, in order to minimize future service costs.
2. Valves may not be installed with stems below the horizontal plane to prevent actuator damage due to stem seal leakage, or accumulation of particulate in the stem packing.
3. If so rated, valves controlling steam should be installed with the actuator beside the valve, not above it, and use a Class F rated motor.
4. Superheated steam must not exceed the maximum operating temperature of the valve.
5. A water filtration and treatment system shall be installed and operated according to the requirements of Division 23 25 13, Water Treatment for Closed-Loop Hydronic Systems. The presence of excess rust in the system will void the manufacturer's warranty.
6. Actuated valves shall be capable of closing off against their maximum operating differential pressure. Seat leakage when closed shall not exceed 0.009 gpm (33 mL/m).
7. All actuators must be able to operate from 32 to 120°F (0 to 50 C) ambient temperature, as measured at the actuator.
8. Actuators shall be constructed of materials resistant to condensation when used to control chilled water. Actuator damage due to condensation or falling water shall not be cause for warranty replacement.
9. Two-position actuators shall be designed for a minimum of 100,000 full-stroke cycles at rated load and temperature.
10. All valves and actuators shall be manufactured under ISO 9001 International Quality Control Standards.
11. Valves and actuators shall be as manufactured by Honeywell.

Cartridge Cage Valves and Dedicated Actuators

23 00 00 HEATING, VENTILATING, AND AIR-CONDITIONING (HVAC)

23 09 00 Instrumentation and Control for HVAC

23 09 13 Instrumentation and Control Devices for HVAC

23 09 13.33 Control Valves

Cartridge Cage Valves and Dedicated Actuators

Mounting and Wiring

1. Valves shall be cast bronze with sweat or female national pipe thread pipe fittings in sizes from ½ up to 1 ¼ inches (DN15 to DN32). Flare or inverted flare pipe fittings shall be available for ½ inch (DN15) sizes, with inverted flare-to-sweat adapters for larger pipe sizes.
2. Valves shall be compact size capable of fitting inside terminal equipment such as fan coil units or unit ventilators.
3. Valves shall provide quick open, linear, or modified equal percentage flow control characteristics. Valve plug and seat construction shall be cage style using resilient seat materials for high differential pressure close-off. Two-way valves shall be capable of being used with flow in either direction.
4. Three-way valves shall have A-AB-B porting and may be used for mixing or diverting control with tight close-off in coil-bypass applications.
5. Valves bodies shall have static pressure ratings of 300 psig (2000 kPa) at 200°F (93 C) minimum.
6. Actuators shall be direct coupled type requiring neither crank-arm nor linkage and direct mount to the associated Honeywell valve family using a snap-on, twist-lock collar, and be removable without the use of tools.
7. Actuators shall provide plenum-rated, lead wire connections with adapter for ½ inch nominal flexible conduit where mechanical protection is required by local codes.
8. Valve actuator shall be capable of operating on 24 Vac Class II power (Safety Extra-Low Voltage), or be UL Recognized or CSA Certified to U.S. and Canadian Standards for use with line voltage.

Control

1. The actuator shall provide two-position, floating, or modulating control. Modulating control refers to direct acceptance of 2-10 Vdc or, with addition of a 500 ohm resistor, a 4-20 mA input signal. Floating control refers to direct acceptance of 24 Vac pulse-width modulated open and close commands from a tri-state (SP3T) controller. Two-position control shall be in the form of 24 Vac power controlled by SPST switch.
2. Two-position and floating control models shall be available with optional SPDT pilot-duty auxiliary switch for position verification feedback.
3. Actuators will be available with electronic fail-safe operation as optional, and shall also accept SPST pulse width modulated control signals.

Other

1. All valves must be field serviceable without the need to remove the valve from the piping, in order to minimize future service costs.
2. Valves may not be installed with stems below the horizontal plane to prevent actuator damage due to stem seal leakage, or accumulation of particulate in the stem packing.
3. A water filtration and treatment system shall be installed and operated according to the requirements of Division 23 25 13, Water Treatment for Closed-Loop Hydronic Systems. The presence of excess rust in the system will void the manufacturer's warranty. A side stream mechanical filtration system, 50 micron or smaller, filtering no more than 10% of system flow, shall be required for the entire building.
4. Actuated valves shall be capable of closing off against a maximum operating differential pressure of 60 psid (400 kPa), without cavitation or water hammer. The valve seat shall be a bubble-tight design.
5. All actuators must be able to operate from 32 to 150°F (0 to 65 C) ambient temperature, as measured at the actuator.
6. Actuators shall be constructed of materials resistant to condensation when used to control chilled water. Actuator damage due to condensation or falling water shall not be cause for warranty replacement.
7. Proportional actuators shall be designed for a minimum of 50,000 full-stroke cycles, and 1,000,000 repositions at rated load and temperature.
8. Two-position actuators shall be designed for a minimum of 100,000 full-stroke cycles at rated load and temperature.
9. All valves and actuators shall be manufactured under ISO 9001 International Quality Control Standards.
10. Valves and actuators shall be as manufactured by Honeywell.

Guide Specifications

Cartridge Globe Valves and Dedicated Actuators

23 00 00 HEATING, VENTILATING, AND AIR-CONDITIONING (HVAC)

23 09 00 Instrumentation and Control for HVAC

23 09 13 Instrumentation and Control Devices for HVAC

23 09 13.33 Control Valves

Cartridge Globe Valves and Dedicated Actuators

Mounting and Wiring

1. Valves shall be brass with female national pipe thread fittings in sizes from ½ up to 1 ¼ inches (DN15 to DN32) and sweat fittings from ½ to ¾ inches (DN15-20).
2. Valves shall be compact size capable of fitting inside terminal equipment such as fan coil units or unit ventilators.
3. Valves ½ to ¾ inches (DN15-20) shall use resilient seat materials for tight close-off, with equal percentage flow characteristics. Two-way valves shall be normally open.
4. Valves 1 to 1 ½ inches (DN25-40) shall use a pressure-balanced, metal seat construction for close-off not less than 145 psid (1000 kPa), with linear flow characteristics.
5. Multiple Cv ratings shall be available in valve sizes ½ to 1 inches (DN15-25).
6. Three-way valves shall feature A-B-AB porting for mixing control in coil-bypass applications. Flow capacity of the B port shall be reduced 20% to more closely balance loop pressure drops in coil-bypass applications.
7. Valves bodies shall have static pressure ratings of 230 psig (1600 kPa) at 230°F (110 C), minimum.
8. Actuators shall be direct coupled type requiring neither crank-arm nor linkage and direct mount to the associated Honeywell valve family using a threaded collar, and be removable without the use of tools.
9. Actuators shall provide plenum-rated, lead wire connections with threaded fittings for ½ inch nominal flexible conduit where mechanical protection is required by local codes.
10. Electronic valve actuators shall be capable of operating on 24 Vac, Class II power (Safety Extra-Low Voltage).

Control

1. The actuator shall provide two-position, floating, or modulating control. Modulating control refers to direct acceptance of 0-10 Vdc, 2-10 Vdc or, with addition of a 500 ohm resistor, a 4-20 mA input signal. Floating control refers to direct acceptance of 24 Vac pulse-width modulated open and close commands from a tri-state (SP3T) controller. Two-position control of non-fail safe actuators shall be in the form of 24 Vac power controlled by SPDT switch. Two-position control of fail safe actuators shall be in the form of 24 Vac power controlled by SPST switch.
2. Pneumatic actuators shall be available for ½ and ¾ inch (DN15-20) valves.
3. Globe valves shall have minimum 50:1 rangeability with an equal percentage or linear flow characteristic.
4. Globe valve proportional actuators shall have response range and travel direction selections.
5. Actuators will be available with optional spring return, fail-safe operation.

Other

1. All valves must be field serviceable without the need to remove the valve from the piping, in order to minimize future service costs.
2. Valves may not be installed with stems below the horizontal plane to prevent actuator damage due to stem seal leakage, or accumulation of particulate in the stem packing.
3. A water filtration and treatment system shall be installed and operated according to the requirements of Division 23 25 13, Water Treatment for Closed-Loop Hydronic Systems. The presence of excess rust in the system will void the manufacturer's warranty.
4. Actuated valves shall be capable of closing off against their maximum operating differential pressure. Seat leakage when closed shall be ANSI/ASME Class III, 0.02% maximum.
5. All actuators must be able to operate from 32 to 122°F (0 to 50 C) ambient temperature, as measured at the actuator.
6. Actuators shall be constructed of materials resistant to condensation when used to control chilled water. Actuator damage due to condensation or falling water shall not be cause for warranty replacement.
7. Proportional actuators shall be designed for a minimum of 50,000 full-stroke cycles, and 1,000,000 repositions at rated load and temperature.
8. All valves and actuators shall be manufactured under ISO 9001 International Quality Control Standards.
9. Valves and actuators shall be as manufactured by Honeywell.

Electric Large Linear Globe Valve Actuators

23 00 00 HEATING, VENTILATING, AND AIR-CONDITIONING (HVAC)

23 09 00 Instrumentation and Control for HVAC

23 09 13 Instrumentation and Control Devices for HVAC

23 09 13.13 Actuators and Operators

Electric Large Linear Globe Valve Actuators

Mounting and Wiring

1. Actuators shall be direct coupled type requiring neither crank-arm nor linkage and be capable of direct mounting to a globe valve.
2. The actuator shall connect to the valve stem using a quick-release engagement.
3. The actuator shall connect to the valve bonnet using set screws or U-bolt. Non-fail safe models shall be available for 1 3/8 inch (35 mm) or 1 7/8 inch (38 mm) diameter valve bonnets of undercut construction.
4. Actuators shall provide wiring terminals located within an integral access cover with conduit connections.
5. Actuators shall have splash-proof covers rated IP54.

Control

1. The actuator shall provide two-position, floating, or modulating control. Modulating control refers to direct acceptance of 0-10 Vdc, 2-10 Vdc or with addition of a 500 ohm resistor a 4-20 mA input signal. Floating control refers to direct acceptance of 24 Vac pulse-width modulated open and close commands from a tri-state (SP3T) controller. Two-position control for non-fail safe actuators shall be in the form of 24 Vac power controlled by an SPDT switch.
2. Modulating actuators shall have a travel direction control switch. Floating actuator travel will be selected by choice of terminal wiring.
3. Modulating control models shall have 0-10 or 2-10 Vdc feedback signal.
4. SPDT switch for position verification feedback shall be an available option.

Other

1. All spring return actuators must be designed for either stem extension or stem retraction fail-safe operation with a continuously engaged mechanical return spring. This spring must return the actuator to a fail-safe position within 10-15 seconds of power loss.
2. Fail-safe spring return actuators shall be available with force rating of 135 lb (600 N). Valve stroke shall be 3/4 inch (20 mm).
3. Non fail safe actuators shall be available with force ratings of 135 or 404 lb (600 or 1800 N), with valve stroke of 3/4 or 1 1/2 inch (20 or 38 mm).
4. All spring return actuators must be able to spring return from 14°F to 122°F (-10 to 70 C) ambient temperature, as measured at the actuator.
5. Valves controlling steam should be installed with the actuator beside the valve, not above it, with the actuator mounting yoke oriented to maximize convective air flow for cooling.
6. A high temperature kit shall be available for further isolation of the actuator from the valve body.
7. All actuators shall be designed for a minimum of 50,000 full-stroke cycles, and 1,000,000 repositions at rated force load and temperature.
8. All actuators shall be plenum-rated per UL873 and cJUL (CSA22.2) Listed, and be manufactured under ISO 9001 International Quality Control Standards.
9. Actuators shall be as manufactured by Honeywell.

Direct-Coupled Electronic Globe Valve Actuators

23 00 00 HEATING, VENTILATING, AND AIR-CONDITIONING (HVAC)

23 09 00 Instrumentation and Control for HVAC

23 09 13 Instrumentation and Control Devices for HVAC

23 09 13.13 Actuators and Operators

Direct-Coupled Electronic Digital Globe Valve Actuators

Mounting and Wiring

1. Actuators shall be direct coupled type requiring neither crank-arm nor linkage and be capable of direct mounting to a Honeywell globe valve from ½ to 3 inches in size (DN15 to DN80).
2. The actuator shall connect to the valve stem using an internally-threaded jackshaft.
3. The actuator shall connect to 1 3/8 inch (35 mm) valve bonnet using a U-bolt. Adapters shall be available for globe valves of other manufacture.
4. Actuators shall provide wiring terminals located within an integral access cover with conduit connections.
5. Actuators shall be available with splash-proof covers rated NEMA 3R for outdoor mounting.

Control

1. The actuator shall provide two-position or floating, or modulating control. Modulating control refers to direct acceptance of 135-270 ohm slide-wire, 2-10 Vdc or, with addition of a 500 ohm resistor, a 4-20 mA input signal. Floating control refers to direct acceptance of 24 Vac pulse-width modulated open and close commands from a tri-state (SP3T) controller. Two-position control for non-fail safe actuators shall be in the form of SPDT 24 Vac power controlled by SPDT switch.
2. Valve actuator shall be capable of operating on 24 Vac or 28 Vdc power supplies.
3. Modulating actuators shall have a travel direction control switch. Floating actuator travel will be selected by choice of terminal wiring.
4. Floating model shall not require continuous power when controlled by triac-based controllers.
5. Continuously-powered models shall have 2-10 Vdc position feedback signal and SPDT pilot duty auxiliary relay as an available option.

Other

1. Non fail safe actuators shall be available with force ratings of 160 lb (710 N) with a self-adjusting, self-calibrating stroke of ½ to 1 inch (12 to 25 mm).
2. Valves controlling steam should be installed with the actuator beside the valve, not above it, with the actuator mounting yoke oriented to maximize convective air flow for cooling.
3. All actuators must be able to operate from 32 to 130°F (0 to 54 C) ambient temperature, as measured at the actuator.
4. All actuators shall be designed for a minimum of 50,000 full-stroke cycles, and 1,000,000 repositions at rated force load and temperature.
5. All actuators shall be plenum-rated per UL873 and cUL (CSA22.2) listed, and be manufactured under ISO 9001 International Quality Control Standards.
6. Actuators shall be as manufactured by Honeywell.

Direct-Coupled Rotary Actuator Globe Valve Linkage

23 00 00 HEATING, VENTILATING, AND AIR-CONDITIONING (HVAC)

23 09 00 Instrumentation and Control for HVAC

23 09 13 Instrumentation and Control Devices for HVAC

23 09 13.13 Actuators and Operators

Direct-Coupled Rotary Actuator Globe Valve Linkage

Mounting and Wiring

1. Valve linkages shall be direct coupled type capable of adapting Honeywell direct-coupled rotary actuators for direct mounting to a Honeywell globe valve from ½ to 3 inches in size (DN15 to DN80).
2. The linkage shall connect to the valve stem using a quick release engagement with anti-spin guides.
3. The linkage will mount to the valve bonnet using a U-bolt.
4. The linkage shall accept one spring or non-spring return actuators up to 300 lb-in (34 Nm) torque, for maximum close-off.
5. The actuators shall connect to the linkage shaft using a removable output hub with a self centering shaft coupling if available or u-bolt hub. This self centering shaft coupling shall provide concentric mounting and include an integral adjustable range-stop mechanism.
6. Actuators shall provide wiring terminals located within an integral access cover with conduit connections.

Control

1. The actuator-linkage combination shall provide two-position or floating, or proportional control. Proportional control refers to direct acceptance of 0-10 Vdc, 2-10 Vdc or with addition of a 500 ohm resistor a 4-20 mA input signal. Floating control refers to direct acceptance of 24 Vac pulse-width modulated open and close commands from a tri-state (SP3T) controller. Two-position control for non-fail safe actuators shall be in the form of SPDT 24 Vac power controlled by SPDT switch.
1. Proportional control models provide a 2-10 Vdc feedback signal.
2. Proportional actuators shall have a rotation direction control switch accessible on the cover to change between proportional or floating control.

Other

1. All spring return actuator-linkage combinations must be designed for either valve stem extend or retract fail-safe operation with a continuously engaged mechanical return spring. This spring must return the actuator to a fail-safe position within 20-25 seconds of power loss.
2. All spring return actuators must be able to spring return from -40 to 189°F (-40 to 87 C).
3. Valves controlling steam should be installed with the linkage beside the valve, not above it, with the actuator mounting yoke oriented to maximize convective air flow for cooling.
4. A high temperature kit shall be available for further isolation of the linkage and actuator from the valve body.
5. All actuators shall be designed for a minimum of 60,000 full-stroke cycles at actuator rated torque and temperature, and 1,500,000 repositions.
6. Run time shall be constant and independent of: load, temperature, and supply voltage (within specifications).
7. All actuators shall be plenum-rated per UL873 and cUL (CSA22.2) listed, and be manufactured under ISO 9001 International Quality Control Standards.
8. Actuators shall be as manufactured by Honeywell.

Tandem Direct-Coupled Rotary Actuator Globe Valve Linkage

23 00 00 HEATING, VENTILATING, AND AIR-CONDITIONING (HVAC)

23 09 00 Instrumentation and Control for HVAC

23 09 13 Instrumentation and Control Devices for HVAC

23 09 13.13 Actuators and Operators

Tandem Direct-Coupled Rotary Actuator Globe Valve Linkage

Mounting and Wiring

1. Valve linkages shall be direct coupled type capable of adapting Honeywell direct-coupled rotary actuators for direct mounting to a Honeywell globe valve from ½ to 3 inches in size (DN15 to DN80), or from 4 to 6 inches (DN100 to DN160).
2. Valve stem stroke will be ¾ or 1 ½ inches.
3. The linkage shall connect to the valve stem using a threaded jackshaft. The valve stem shall be prevented from spinning by use of a jam nut to lock the valve stem to the jackshaft.
4. The linkage shall mount to the valve bonnet using a full collar.
5. The linkage shall accept one or two, spring or non-spring return actuators up to 300 lb-in (34 Nm) torque each, for maximum close-off.
6. The actuators shall connect to the linkage shaft using a removable output hub with a self centering shaft coupling if available or u-bolt hub. This self centering shaft coupling shall provide concentric mounting and include an integral adjustable range-stop mechanism.
7. Actuators shall provide wiring terminals located within an integral access cover with conduit connections.

Control

1. The actuator-linkage combination shall provide two-position or floating, or proportional control. Proportional control refers to direct acceptance of 0-10 Vdc, 2-10 Vdc or with addition of a 500 ohm resistor a 4-20 mA input signal. Floating control refers to direct acceptance of 24 Vac pulse-width modulated open and close commands from a tri-state (SP3T) controller. Two-position control for non-fail safe actuators shall be in the form of SPDT 24 Vac power controlled by SPDT switch.
1. Proportional control models provide a 2-10 Vdc feedback signal.
2. Proportional actuators shall have a rotation direction control switch accessible on the cover to change between proportional or floating control.

Other

1. All spring return actuator-linkage combinations must be designed for either valve stem extend or retract fail-safe operation with a continuously engaged mechanical return spring. This spring must return the actuator to a fail-safe position within 20-25 seconds of power loss.
2. All spring return actuators must be able to spring return from -40 to 189°F (-40 to 87 C).
3. Valves controlling steam should be installed with the linkage beside the valve, not above it, with the actuator mounting yoke oriented to maximize convective air flow for cooling.
4. All actuators shall be designed for a minimum of 60,000 full-stroke cycles at actuator rated torque and temperature, and 1,500,000 repositions.
5. Run time shall be constant and independent of: load, temperature, and supply voltage (within specifications).
6. All actuators shall be plenum-rated per UL873 and cUL (CSA22.2) listed, and be manufactured under ISO 9001 International Quality Control Standards.
7. Actuators shall be as manufactured by Honeywell.

Footmount Globe Valve Actuators

23 00 00 HEATING, VENTILATING, AND AIR-CONDITIONING (HVAC)

23 09 00 Instrumentation and Control for HVAC

23 09 13 Instrumentation and Control Devices for HVAC

23 09 13.13 Actuators and Operators

Footmount Globe Valve Actuators

Mounting and Wiring

1. Actuators shall be direct coupled type requiring a Q5001 linkage and be capable of direct mounting to a Honeywell globe valve from ½ to 6 inches in size (DN15 to DN80).
2. The actuator shall connect to the valve stem using a stem button and clip retainer with an anti-spin clip to prevent the valve stem from spinning.
3. The actuator shall connect to the valve bonnet using a Q5001 linkage.
4. Actuators shall provide wiring terminals located within an integral access cover with conduit connections.
5. Actuators shall be available with splash-proof covers rated NEMA 3R for outdoor mounting.

Control

1. The actuator shall provide two-position or floating, or proportional control. Proportional control refers to direct acceptance of 135-270 ohm slide-wire, 2-10 Vdc or, with addition of a 500 ohm resistor, a 4-20 mA input signal. Floating control refers to direct acceptance of 24 Vac pulse-width modulated open and close commands from a tri-state (SP3T) controller. Two-position control for non-fail safe actuators shall be in the form of SPDT 24 Vac power controlled by SPDT switch.
2. Valve actuator shall be capable of operating 24 Vac, 120 Vac, or Multi tap (24,120, 230 Vac) power supplies.
3. Proportional actuators shall have a travel direction by turning the motor around and running the linkage from the corresponding shaft. Floating actuator travel shall have a travel direction by turning the motor around and running the linkage from the corresponding shaft.
4. Proportional control models shall have 2-10 Vdc feedback signal with SPDT switch for position verification feedback as an available option.

Other

1. Non-Fail safe actuators shall be available with force ratings of 35 lb-in (4.0Nm), 75 lb-in (8.5Nm), 150 lb-in (17Nm), and 300 lb-in (34Nm).
2. Valves controlling steam should be installed with the actuator beside the valve, not above it, with the actuator mounting linkage oriented to maximize convective air flow for cooling.
3. All actuators must be able to operate from -40 to 150 F (0 to 60 C) ambient temperature, as measured at the actuator.
4. All actuators shall be designed for a minimum of 60,000 full-stroke cycles, and 1,500,000 repositions at rated force load and temperature.
5. All actuators shall be plenum-rated per cUL 174H listed, CE, and be manufactured under ISO 9001 International Quality Control Standards.
6. Actuators shall be as manufactured by Honeywell.

Footmount Globe Valve Actuators

23 00 00 HEATING, VENTILATING, AND AIR-CONDITIONING (HVAC)

23 09 00 Instrumentation and Control for HVAC

23 09 13 Instrumentation and Control Devices for HVAC

23 09 13.13 Actuators and Operators

Footmount Globe Valve Actuators

Mounting and Wiring

1. Actuators shall be direct coupled type requiring a Q5001 linkage and be capable of direct mounting to a Honeywell globe valve from ½ to 6 inches in size (DN15 to DN80).
2. The actuator shall connect to the valve stem using a stem button and clip retainer with an anti-spin clip to prevent the valve stem from spinning.
3. The actuator shall connect to the valve bonnet using a Q5001 linkage.
4. Actuators shall provide wiring terminals located within an integral access cover with conduit connections.
5. Actuators shall be available with splash-proof covers rated NEMA 3R for outdoor mounting.

Control

1. The actuator shall provide two-position or floating, or proportional control. Proportional control refers to direct acceptance of 135-270 ohm slide-wire, 2-10 Vdc or, with addition of a 500 ohm resistor, a 4-20 mA input signal. Floating control refers to direct acceptance of 24 Vac pulse-width modulated open and close commands from a tri-state (SP3T) controller. Two-position control for non-fail safe actuators shall be in the form of SPDT 24 Vac power controlled by SPDT switch.
2. Valve actuator shall be capable of operating 24 Vac, 120 Vac, or Multi tap (24,120, 230 Vac) power supplies.
3. Proportional actuators shall change direction by turning the motor around and running the linkage from the corresponding shaft. Floating actuator travel shall change direction by turning the motor around and running the linkage from the corresponding shaft.
4. Proportional control models shall have 2-10 Vdc feedback signal with SPDT switch for position verification feedback as an available option.

Other



1. Fail safe actuators shall be available with force ratings of 60 lb-in (6.8Nm).
2. Valves controlling steam should be installed with the actuator beside the valve, not above it, with the actuator mounting linkage oriented to maximize convective air flow for cooling.
3. All actuators must be able to operate from -40 to 150 F (0 to 60 C) ambient temperature, as measured at the actuator.
4. All actuators shall be designed for a minimum of 60,000 full-stroke cycles, and 1,500,000 repositions at rated force load and temperature.
5. All actuators shall be plenum-rated per cUL 174H listed, CE, and be manufactured under ISO 9001 International Quality Control Standards.
6. Actuators shall be as manufactured by Honeywell.

Section 6: Accessories



Ball Joints, Push Rod Accessories	186
Control, Positioning, Feedback Accessories	186
Mounting Accessories.....	187
Rotational Limiters, Position Indicators.....	188
Crankarms	189
Shaft Adaptor Accessories.....	189
Enclosure Accessories	190
Q7002 Interface Modules.....	190
Miscellaneous Accessories	190
Accessories for Obsolete Actuators	191
Valve Actuator Accessories	192
VU Series Fan Coil Actuator Accessories	192
Pneumatic Damper Actuator Parts and Accessories.....	193
Pneumatic Valve Actuator Parts and Accessories	196
Foot Mounted Motor Accessories	198
Damper and Valve Linkage Accessories.....	200

Damper And Actuator Accessories

Ball Joints, Push Rod Accessories



	Product Number	Description	Used With
	103598	Ball Joint (1/4 in.) Used With: All Actuators and Dampers	All Actuators and Dampers
	27518	Crankarm balljoint with 1/4 - 28 UNF male threads, fits 5-16 inch diameter push rods	All Actuators and Dampers
	27518	Crankarm balljoint with 1/4 - 28 UNF male threads, fits 5-16 inch diameter push rods	All Actuators and Dampers
	27520A	Push Rod (5/16 in. dia., 5 in. length) Used With: All Actuators and Dampers	All Actuators and Dampers
	27520B	Push Rod (5/16 in. dia., 10 in. length) Used With: All Actuators and Dampers	All Actuators and Dampers
	27520C	Push Rod (5/16 in. dia., 12 in. length)	All Actuators and Dampers
	27520D	Push Rod (5/16 in. dia., 15 in. length) Used With: All Actuators and Dampers	All Actuators and Dampers
	27520E	Push Rod (5/16 in. dia., 18 in. length) Used With: All Actuators and Dampers	All Actuators and Dampers
	27520G	Push Rod (5/16 in. dia., 24 in. length)	All Actuators and Dampers
	27520H	Push Rod (5/16 in. dia., 28 in. length) Used With: All Actuators and Dampers	All Actuators and Dampers
	27520K	Push Rod (5/16 in. dia., 36 in. length)	All Actuators and Dampers
	27520L	Push Rod (5/16 in. dia., 48 in. length)	All Actuators and Dampers
	27520Q	Push Rod (5/16 in. dia., 8 in. length) Used With: All Actuators and Dampers	All Actuators and Dampers

Control, Positioning, Feedback Accessories



	Product Number	Description	Used With
	200976A	Auxiliary Feedback Potentiometer (0 to 500 ohm) Used With: ML6161, ML6174, ML7161, ML7174	ML6161, ML6174, ML7161, ML7174
	200976C	Auxiliary Feedback Potentiometer (0 to 2000 ohm) Used With: ML6161, ML6174, ML7161, ML7174	ML6161, ML6174, ML7161, ML7174
	201052A	Auxiliary Switch Package, Single Used With: ML6161, ML6174, ML7161, ML7174	ML6161, ML6174, ML7161, ML7174
	201052B	Auxiliary Switch Package, Double Used With: ML6161, ML6174, ML7161, ML7174	ML6161, ML6174, ML7161, ML7174
	205860	Electronic Remote Minimum Position Potentiometer Used With: Proportional Actuators	Proportional Actuators

Damper And Actuator Accessories

Control, Positioning, Feedback Accessories (cont.)





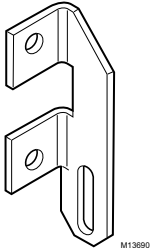
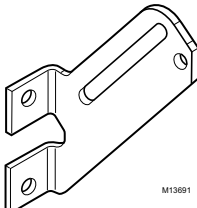

	Product Number	Description	Used With
	32003532-005	High Temperature Dual Switch Assembly	ML4105, ML8105, ML4115, ML8115, ML4125, ML8125, ML4135, ML8135, MS4209, MS4309, MS4709, MS4809, MS8209, MS8309
	32006306-001	Resistor Kit (500 ohm, converts 4-20mA to 2-10Vdc)	Proportional Actuators
	SSW2	Auxiliary Switch Package - Low Torque Non Spring Return	MN Actuator Series (44 in-lb, 88 in-lb)
	SW2-US	Auxiliary Switch Package (2 adjustable SPDT switches)	MS and MN High Torque Series Actuators (MNXX20 and XX34)

Mounting Accessories

	Product Number	Description	Used With
	205649	Mounting Bracket Used With: 150 and 300 lb-in NSR and SR (except 25, 53 and 142 lb-in) Actuators	150 and 300 lb-in. NSR and SR (except 25, 53 and 142 lb-in) Actuators
	32007205-001	Direct Coupled Actuator Mounting Bracket Used With: Damper with External Actuator Mounting (i.e., 32007205-005 Kit)	Damper with External Actuator Mounting (i.e., 32007205-005 Kit)
	32007205-002	Damper Blade Drive Lever (Small) Used With: All Actuators and Dampers	All Actuators and Dampers
	32007205-003	Damper Blade Drive Lever (Large) Used With: All Actuators and Dampers	All Actuators and Dampers

Damper And Actuator Accessories

Mounting Accessories (cont.)



	Product Number	Description	Used With
	32007205-004	Retaining Clip, Damper External Drive Pin Used With: Damper with External Actuator Mounting (i.e., 32007205-005 Kit)	Damper with External Actuator Mounting (i.e., 32007205-005 Kit)
	32007205-005	Damper External Drive Pin Kit Used With: Damper with External Actuator Mounting (i.e., 32007205-005 Kit)	Damper with External Actuator Mounting (i.e., 32007205-005 Kit)
	32007205-006	Damper Axle Coupling Used With: Multi-Section Dampers	Multi-Section Dampers
	32007205-007	Jumper Bracket Used With: Multi-Section Dampers	Multi-Section Dampers
	50000407-001	Actuator Tandem Mounting Kit	N20 Actuators; N34 Actuators; S05, S10, S20 Actuators
	50001194-001	Foot Mounting Kit	MS and MN High Torque Series Actuators (MNXX20 and XX34)
	50006427-001	Flexible Anti-Rotation Bracket	N20 Actuators; N34 Actuators; S05, S10, S20 Actuators

Rotational Limiters, Position Indicators







	Product Number	Description	Used With
	4074ENJ	Minimum Position Kit Used With: ML6161, ML6174, ML7161, ML7174	ML6161, ML6174, ML7161, ML7174

Damper And Actuator Accessories

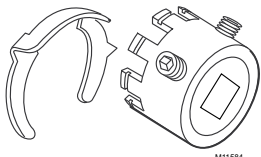
Crankarms



	Product Number	Description	Used With
	205830A	Rotary-to-Linear Kit Used With: 35 and 70 lb-in NSR and 25, 44, 53, and 88 lb-in SR Actuators	35 and 70 lb-in.NSR
	26026G	Damper Crank Arm, 1/2 in. damper shaft	All Actuators and Damper

Shaft Adaptor Accessories

	Product Number	Description	Used With
	205843B	Hub Insert, 1 in. (25mm) Round Used With: 300 lb-in NSR Actuators (ML Series)	300 lb-in.NSR Actuators (ML Series)
	32003167-001	3/8 in. Shaft Adapter Used With: ML6161, ML6174, ML7161, ML7174, ML7999	ML6161; ML6174; ML7161; ML7174; ML7999
	32003168-001	Short Shaft Adapter (3/4 in. to 1/2 in.) Used With: All Actuators and Dampers	All Actuators and Dampers
	32003168-002	Short Shaft Adapter (5/8 in. to 1/2 in.) Used With: All Actuators and Dampers	All Actuators and Dampers
	32003168-003	Short Shaft Adapter (9/16 in. to 1/2 in.) Used With: All Actuators and Dampers	All Actuators and Dampers
	32004254-001	Self-Centering Shaft Adapter Used With: N20 Actuators	N20 Actuators
	32004254-001	Self-Centering Shaft Adapter Used With: N20 Actuators	N20 Actuators
	32004254-002	Self-Centering Shaft Adapter Used With: S05, S10, S20 Actuators	S05, S10, S20 Actuators
	32004254-003	Self-Centering Shaft Adapter Used With: N34 Actuators	N34 Actuators
	4074ENY	3/8 in. Shaft Kit Used With: ML6161, ML6174, ML7161, ML7174	ML6161, ML6174, ML7161, ML7174
	4074EVK	Short Shaft Kit Used With: ML6161, ML6174, ML7161, ML7174	ML6161, ML6174, ML7161, ML7174

Damper And Actuator Accessories

Enclosure Accessories

	Product Number	Description	Used With
	32003036-001	Weather Enclosure Used With: All Actuators	All Actuators
	50005859-001	NEMA 4 Enclosure for Direct Coupled Actuator	142 lb-in. Spring Return Actuators; ML6161, ML6174, ML7161, ML7174; N20 Actuators; N34 Actuators; 150 lb-in. NSR Actuators (ML Series); 25 and 53 lb-in.SR Actuators (ML Series); 300 lb-in.NSR Actuators (ML Series); S05, S10, S20 Actuators
	7640QW	Enclosure for Conduit Connection Used With: ML6161, ML6174, ML7161, ML7174	ML6161, ML6174, ML7161, ML7174

Q7002 Interface Modules



	Product Number	Description	Used With
	Q7002B1009	Transducer, Accepts dc voltage, current, or resistive input and provides a voltage or current output	Direct-Coupled Proportional Actuators and Modutrol Motors
	Q7002C1007	Transducer, Accepts a pulse-width modulation (PWM) signal and provides a voltage output	Direct-Coupled Proportional Actuators and Modutrol Motors

Miscellaneous Accessories

	Product Number	Description	Used With
	32000085-001	Strain Relief Fitting (10 pack)	MS and MN Series Actuators

Damper And Actuator Accessories

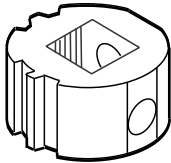
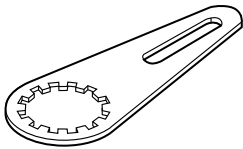
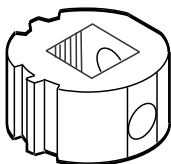
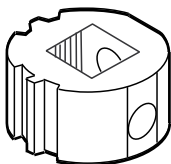
Accessories for Obsolete Actuators

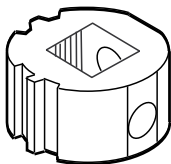
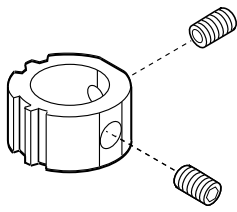
	Product Number	Description	Used With
	205617	Hub Insert, 3/4 in. (19mm) Used With: 150 lb-in NSR Actuators (ML Series)	150 lb-in. NSR Actuators (ML Series)
	205685	Crank Arm Kit Used With: 150 lb-in NSR Actuators (ML Series)	150 lb-in. NSR Actuators (ML Series)
	205753	Hub Insert, 3/8 in. (10mm) Used With: 150 lb-in NSR and 25 and 53 lb-in Actuators (ML Series)	150 lb-in.NSR and 25 and 53 lb-in.Actuators (ML Series)
	205755	Hub Insert, 1/2 in. (13mm) Used With: 150 lb-in NSR and 25 and 53 lb-in Actuators (ML Series)	150 lb-in.NSR and 25 and 53 lb-in.Actuators (ML Series)
	205784	Mounting Bracket Used With: 25 and 53 lb-in SR Actuators (ML Series)	25 and 53 lb-in.SR Actuators (ML Series)
	205846	Crank Arm Kit Used With: 300 lb-in NSR Actuators (ML Series)	300 lb-in.NSR Actuators (ML Series)
	205849A	Hub Insert, 5/8 in. (17mm) Round Used With: 300 lb-in NSR Actuators (ML Series)	300 lb-in.NSR Actuators (ML Series)
	205856B	Hub Insert, 3/4 in. (19mm) Round Used With: 300 lb-in NSR Actuators (ML Series)	300 lb-in.NSR Actuators (ML Series)

Valve Accessories

Valve Actuator Accessories

Product Number	Description	Used With
114191A	Auxiliary Switch Assembly	—
127834A	Switch (made)	—
272629A	Adapter Kit for mounting ML6984/ML7984 to V5045 and VGF standard 2-way valves.	ML6984 or ML7984, V5045; VGF21ES; VGF21LS, VGF22ES; VGF22LS
272630D	Position Feedback and Auxiliary Switch Accessory	ML6984/7984 Series 4000 and higher
272775	Replacement Motor Brush Kit for ML6984/7984	ML6984 or ML7984
43191679-101	Auxiliary Potentiometer for ML6421A	ML6421A
43191679-102	Auxiliary Potentiometer for ML6421B	ML6421B
43191679-111	Potentiometer, 10k ohm, for ML6425, ML7425	ML6425 or ML7425
43191679-112	Potentiometer, 220 ohm for ML6425, ML7425	ML6425 or ML7425
43191680-102	Dual Auxiliary Switch for CREVAL actuators	ML6421, ML7421
43191680-105	Dual Auxiliary Switch for CREVAL actuators	ML6420, ML6425, ML7420, ML7425
43196000-001	High Temperature Kit for actuators with 3/4" stroke	ML6420, ML6421, ML6425, ML7420, ML7421, or ML7425
43196000--038	High Temperature Kit for actuators with 1-1/2" stroke	ML6421, ML7421



VU Series Fan Coil Actuator Accessories

Product Number	Description	Used With
272885C	Nickel-plated replacement motor for 24V VU-series valve actuators	VU843A, VU844A
272885D	Nickel-plated replacement motor for 120 VU-series valve actuators	VU443A1008/A1180/E1009; VU444A1007/A1155

Pneumatic Damper Actuator Parts and Accessories

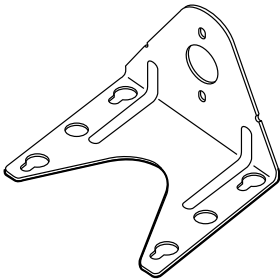
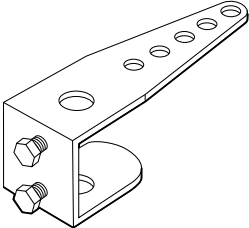
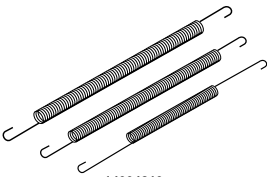
	Product Number	Description	Used With
	14001213-001	MP904A and B Diaphragm	MP904A,B
	14002061-001	Damper Linkage Kit w/ Template	MP909E,F
	14002850-001	Angle Bracket 5 3/8 in, 137 mm, long, 5 in, 127 mm, wide	MP909D,E
	14003640-001	Angle Bracket 3 in. (76 mm) long, 3 3/4 in. (95 mm) wide, 2 3/4 in. (70 mm) high	MP913; MP909D
	14004062-001	External Trunnion Mounting Bracket	MP918A,B; MP909E,H
	14004062-002	Internal N.C. Trunnion Mounting Bracket	MP918A,B; MP909E,H
	14004062-003	Internal N.O. Trunnion Mounting Bracket	MP918A,B; MP909E,H
	14004106-001	Actuator pushrod for conversion of internal N.C. to external	MP918A,B; MP909E,H
	14004106-002	Push rod assembly for internal N.C.	MP918A,B; MP909E,H
	14004107-001	Crankarm Assembly for conversion from internal N.C. to external Trunnion mounting	MP918A,B; MP909E,H
	14004136-001	MP904 Positive Positioner Retrofit Kit	MP904A
	14004137-001	Retrofit Kit for adding positive positioner to MP909E or repair of MP909H	MP909E; MP909H
	14004210-001	Feedback Spring Kit includes orange spring (3 psi [21kPa]), yellow spring (5 psi [34 kPa]), and blue spring (10 psi [69 kPa]).	MP909H; MP918A
	14004236-001	Coupler, actuator shaft to 5/16 in, 8 mm, pushrod	MP918
	14004237-002	Bag assembly including 4 hex head slotted drill point screws (14004513-001)	MP918A,B; MP909E,H
	14004241-002	Hitch Pin (Six Sets)	MP918A,B; MP909E,H
	14004242-001	MP918 Top Mount Operator Assembly	MP918A,B

Pneumatic Damper Accessories

Pneumatic Damper Actuator Parts and Accessories (cont.)

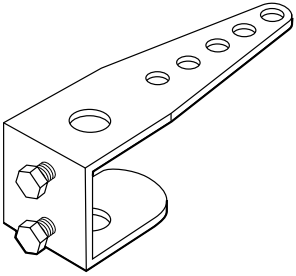
Product Number	Description	Used With
14004264-001	MP918 Repair kit including Positive Positioner, bracket assembly and fittings	MP918A
14004264-002	MP918 Positive Positioner Retrofit Kit includes 10 psi feedback spring	MP918B
14004324-001	Kit for Alternate External Top-Mount, MP909E,H MP918A,B	MP918A,B; MP909E,H
	14004345-001 Positive Positioner Kit, 10 psi feedback spring	MP920B
14004350-001	Steel Clevis Pin (1/4 x 7/8)	MP918
14004577-001	MP953 A, C, and E (Direct Acting, 5 in. diameter) Yoke/Base Assembly	MP953A,C,E
15753692-001	Modular Kit for Jack Shaft Installation of MP909E and MP918B Actuators	MP909E; MP918B
15753693-001	End kit for Jack Shaft Installation of MP909E and MP918B Actuators	MP909E; MP918B
15753694-001	Operator kit for Jack Shaft Installation of MP909E and MP918B Actuators	MP909E; MP918B
26025B	Damper crank arm for 3/8 in. (9.5 mm) diameter axle. Elongated slot for linkage connection. Slot scaled for 40-50-60-75-90 degrees.	MP516; MP909D; MP909E, H
27174B	Damper crank arm for 7/16 in. (11.1 mm) diameter axle. Elongated slot for linkage connection. Slot scaled for 40-50-60-75-90 degrees.	MP516; MP513
309292	MP516A Diaphragm	MP516
309389J	Mounting Bracket and Linkage	MP516
312809C	MP904A and B Tube and Diaphragm Assembly	MP904A,B
312817	MP953C (5 in. diameter) Cover	MP953C (5 in.)
312867C	Damper Crank Arm for 1/2 in. (12.7mm) diameter axle. Elongated slot for linkage connection. Slot scaled for 45-60-75-90 degrees	MP516; MP909D; MP909E; MP909H
312867H	Externally mounted Linkage Kit	MP516; MP909D,E,H
314100	MP909A Replacement Diaphragm	MP909A
314231	MP909B Replacement Diaphragm	MP909B
314316A	Crank Arm Assembly	MP516

Pneumatic Damper Actuator Parts and Accessories (cont.)

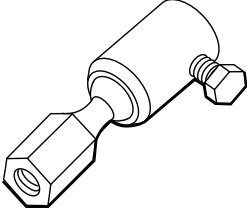
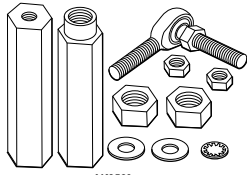
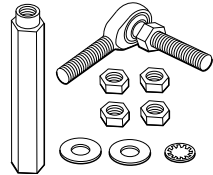
	Product Number	Description	Used With
	314440A	MP909 - Clevis, Clevis Pin and Cotter Pin Assembly	MP909
	314503	MP909C Replacement Diaphragm	MP909C
	315321	Crankarm Balljoint (with 1/4 in male threads), fits 5/16 in. diameter pushrod	MP516; MP909D,E,H; MP913
	315321G	Crankarm and Linkage	MP909A,D
	315439/0062	Clevis	MP909D
	315781	Motor shaft balljoint with 3/8 - 16 UNC female threads, fits 5/16 inch diameter pushrods.	MP909D,E,H; MP913
	315782	Balljoint (9/16 in.-18 UNC) accepts 5/16 in. Pushrod	MP920B
	AK3558	Swivel Bracket Bag Assembly	MP920B
	AK3560	Balljoint, 3/8-24 threaded stud with couplings for 5/8-11 threaded rod and actuator shaft	MP920B
	AK3561	Balljoint, 3/8-24 threaded stud with couplings for 3/8-16 threaded rod	MP920B
	CCT2718	Threaded rod for shaft extension	MP918
	CCT2725	Rod coupling for shaft extension	MP918

Pneumatic Valve Accessories

Pneumatic Valve Actuator Parts and Accessories



Product Number	Description	Used With
14002039-001	MP953D Diaphragm Sleeve	MP953B,D,F
14002040-002	MP953D Diaphragm	MP953B,D,F
14003124-002	MP953B,D,F Diaphragm Repair Kit (includes 14002039-001 and 14002040-002)	MP953B,D,F
14004138-001	MP953B,F (Reverse Acting) Positive Positioner Retrofit Kit	MP953B,F
14004139-001	MP953A,E (Direct Acting, 8 in. and 13 in. diameter, 3/4 in. stroke) Positive Positioner Retrofit Kit	MP953A,E
14004140-001	MP953A,E (Direct Acting, 8 in. and 13 in. diameter, 1-1/2 in. stroke) Positive Positioner Retrofit Kit	MP953A,E
14004211-001	MP953E (8 in. and 13 in. diameter, 3/4 in. stroke) Feedback Spring Kit	MP953E
14004212-001	MP953E (8 in. and 13 in. diameter, 1-1/2 in. stroke) Feedback Spring Kit	MP953E
14004213-001	MP953F (Reverse Acting) Feedback Spring Kit	MP953F
14004214-001	MP953A,E (5 in. diameter) 3/4 inch stroke Positive Positioner Retrofit Kit	MP953A,E
14004298-001	Thread forming Screw, Size 4-40	MP953D,F
14004298-003	MP953C,E (5 in. dia.) and MP953B,D,F (7-1/8 in. dia.) Actuator Base Screw, size 1/4-20	MP953B,D,F; MP953C,E (5 in.)
14004578-001	MP953 B, D, and F (Reverse Acting, 7-1/8 in. diameter) Yoke/Base Assembly	MP953B,D,F
14004667-001	Offset Crank arm assembly with 2 screws (304725-062), nuts (14004102-001), crank arm (14004655-001) for 1/2 in. Drive Axle	Pneumatic Actuators
14004697-001	Stem extension for 13 in. MP953C,E with 3/4 in. Stroke	MP953C,E
310664	MP953A, C and E (5 in. and 8 in. models only) Tension Spring	MP953A,C,E
310665/0062	Spring Support for MP953	MP953A,C,E (5 in.)
310668	MP953A, C and E (5 in. diameter) High Temperature Silicone Diaphragm Old Style	MP953A,C,E
311393	White Spring, 4-11 psi	MP953C,E
311616	MP953A, C and E (5 in. diameter) Main Spring (2-7 psi spring range - Brown)	MP953A,C,E (5 in.)
311618	MP953A, C and E (5 in. diameter) Main Spring (8-12 psi spring range - Gray)	MP953A,C,E (5 in.)
311749/0605	Cup diaphragm, 8 in. for MP953A, C, E	MP953A,C,E (8 in.)
311750	MP953A, C and E (8 in. diameter) Regular Temperature Neoprene Diaphragm - New Style	MP953A,C,E

Pneumatic Valve Actuator Parts and Accessories (cont.)

Product Number	Description	Used With
311851/0062	Stem extension for 8 in. dia. 3/4 in. stroke MP953A,C,E	MP953A,C,E (8 in.)
311852	Brown Spring for MP953A,C 3/4 inch stroke (8 inch diameter), 2-7 psi range	MP953A,C (8 in., 2-7 psi)
311855	Gray spring for MP953C (8 inch diameter), 8-12 psi range	MP953C
311863	Stem Retainer for the MP953C,E (8 in. diameter)	MP953C,E
312099	1-1/2 in. stroke Spider for 13 in. MP953C and E	MP953C,E
312203	Black Spring for MP953D,F for 8-13 psi range	MP953D,F
312466/0605	Stem Extension for MP953C1489, MP953C1471, MP953E1392, MP953E1400, and MP953E1418	MP953C,E
312471	White Spring for MP953C,E (13 in. dia. 1/2 in. stroke)	MP953C,E (13 in.)
312505	MP953A,C,E (13 in. diameter) regular temperature Neoprene diaphragm New style	MP953A,C,E
312760	MP953A,C,E (5 in. diameter) regular temperature Neoprene diaphragm New style	MP953A,C,E
313745	MP953A, C and E (5 in. diameter) High Temperature Silicone Diaphragm New Style	MP953A,C,E
314153	MP953A, C and E (8 in. diameter) High Temperature Silicone Diaphragm New Style	MP953A,C,E
314646A/0062	Plate, Spring for 13 in. diameter MP953A,C,E	MP953A,C,E
314650A	MP953B, D and F (Reverse Acting) Support Assembly (for Series-2 actuators only, use this Support Assembly and 316059A Yoke Assembly to Convert Series-1 MO/MP953)	MP953B,D,F
314651A	MP953B,D,F (Reverse Acting) yoke assembly for support assembly- with nylon insert for use with old style actuators not made with a Helicoil insert in yoke	MP953B,D,F
314652	Spring for MP953D,F (used in yoke assembly)	MP953D,F
314683/0062	Stem Retainer for 13 in. diameter MP953A,C,E (Latches on Stem Button)	MP953A,C,E (13 in.)
315020	Cup for MP953C,E (13 inch diameter)	MP593C,E (13 in.)
316059A	MP953B, D and F (Reverse Acting) Yoke Assembly for Support Assembly- with helicoil insert	MP953B,D,F

Foot Mounted Motor Accessories

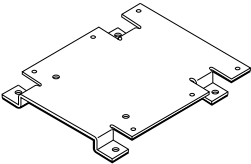
Foot Mounted Motor Accessories

	Product Number	Description	Used With
	203709D2	Screw Terminal Adapter With Zero and Span Adjustment for Series 2 and Series 3 Modutrol IV Motors	Series 2 and Series 3 Modutrol IV™ Motor
	220738A	Adapter Bracket. Adjusts shaft height to match Modutrol III Motors	Mod IV Actuator to match shaft height of Mod III Actuator
	220741A2-61	Screw Terminal Adapter Kit for Series 61 Modutrol IV Series 2 motors Converts quick-connect terminals to screw terminals	Series 61 Mod IV Motor
	220741A2-62	Screw Terminal Adapter Kit for Series 62 Series Modutrol IV Series 2 motors Converts quick-connect terminals to screw terminals	Series 62 Mod IV Motor
	220741A2-71	Screw Terminal Adapter Kit for Series 71 Modutrol IV Series 2 motors Converts quick-connect terminals to screw terminals	Series 71 Mod IV Motor
	220741A2-72	Screw Terminal Adapter Kit for Series 72 Modutrol IV Series 2 motors Converts quick-connect terminals to screw terminals	Series 72 Mod IV Motor
	220741A2-90	Screw Terminal Adapter Kit for Series 90 Modutrol IV Series 2 and Series 3 motors. Converts quick-connect terminals to screw terminals	Series 90 Mod IV Motor
	220741A2-TP	Screw Terminal Adapter Kit for 2-position Modutrol IV Series 2 motors Converts quick-connect terminals to screw terminals	Two Position for use with M4XXX and M8XXX Mod IV Motors
	221455A	Infinitely adjustable Motor Crank Arm	Modutrol IV Motors

Foot Mounted Motor Accessories

Foot Mounted Motor Accessories (cont.)

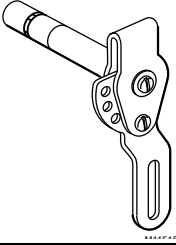
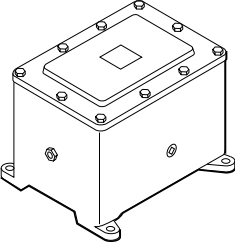
	Product Number	Description	Used With
	221508A2	Resistor Board Assembly for Series 2 Modutrol IV Motors	Series 2 Modutrol IV Motors
	4074ERU	Weatherproofing kit. Protects motor from driving rain when mounted in any position	Fits all Modutrol IV motors
	7617DM	Coupling- Must be used with ES-650-117 explosion-proof housing	ES-650-117
	ES-650-117	Explosion-Proof Housing encloses motor for use in explosive atmospheres. To order, contact: EGS Enclosures, (281) 774-3763; or write to: EGS Enclosures in Houston, TX Karen Barfield 281-774-3763 Karen.barfield@egseg.com part number ES-650-117	Modutrol IV Motors, not for use with Q5001 (or any other valve linkages)

Damper And Valve Accessories

Damper and Valve Linkage Accessories

Product Number	Description	Used With
102546	Ball Joint, 5/16 in.	Damper Linkages
101662A/0021	Motor Mounting Bracket Assembly for Q605	Q605
102931/0021	Adapter arm for less than 90 degree rotation for the Q605	Q605
104643A	Adapter for driving 2 dampers from 1 crank arm	Modutrol IV Motors
220828AA	Valve bracket assembly, Q5001	Q5001
220845/0767	Retainer button for Q5001	Q5001
220848A	Q5001 Cam with 1/2 in. stroke	Q5001
220852A	Stroke Indicator, Q5001	Q5001
220858A	9/16 inch lift Q5001 linkage cam assembly with 9/16 in stroke	Q5001
220861A	3/4 inch lift Q5001 linkage cam assembly with 3/4 in stroke	Q5001
220863A	1 inch lift Q5001 linkage cam assembly with 1 inch stroke	Q5001
220864A	1 1/8 inch lift Q5001 linkage cam assembly with 1-1/8 in stroke	Q5001
220865A	1 1/4 inch lift Q5001 linkage cam assembly with 1-1/4 in stroke	Q5001
220867A	1 1/2 inch lift Q5001 linkage cam assembly with 1-1/2 in stroke.	Q5001
220874/0767	9/16 inch anti spin clip for Q5001	Q5001
26025F	Damper Arm, 3/8 in. shaft	—
26026B	Damper Arm, 1/2 in. shaft, 3 in. long	—
32004629-001	Bonnet adapter kit to adapt Siemens (Landis/Power) Flowrite 599 1/2 inch to 3 inch globe valves with Q5020A or Q5009B	Siemms valves
32004629-002	Bonnet Adapter Kit, Johnson Controls 1/2 to 3/4 in., Q5020	Johnson valves; Q5020
32004629-003	Bonnet Adapter Kit, Johnson Controls 1 to 2 in., Q5020	Johnson valves; Q5020
32004629-004	Bonnet Adapter Kit, Siebe 1/2 to 2 in., Q5020	Siebe valves; Q5020
4074ETB	Antispin Kit, Q5001	Q5001
7617ACL	Bag Assembly, Q605 includes Damper arm, motor crankarm, and 2 ball joints	Q605

Section 8: Competitive Cross Reference

Direct Coupled Actuator	202
Control Ball Valve	
2-Way Valve	220
2-Way Valve + Non-Spring Return Floating Actuator.....	221
2-Way Valve + Non-Spring Return Modulating Actuator.....	222
2-Way Valve + Spring Return, 2-Position Actuator	223
2-Way Valve + Spring Return Floating Actuator.....	224
2-Way Valve + Spring Return Modulating Actuator	225
Threaded Globe Valves	226
Flanged Globe Valves.....	227
Pneumatics	228
Modutrol IV Motor	231

Competitive Cross Reference

Direct Coupled Actuator

Belimo Model	Torque (lb-in.)	Control Signal	Power	Feedback	Switches	Timing (sec)	Honeywell Actuator	Torque (lb-in.)	Control Signal ^a	Power	Feedback ^a	Switches	Timing (sec)
LMB24-3-P5-T	45 lb-in. (5 Nm)	On/Off, Floating	24 Vac/Vdc	0-5 kOhm	—	95	ML6174A2002 + 200976A	70 lb-in. (8 Nm)	On/Off, Floating	24 Vac (±20%)	500 Ohm	—	95
							ML6174A2002 + 200976C	—	On/Off, Floating	24 Vac (±20%)	2 kOhm	—	95
LMB24-3-P10-T	45 lb-in. (5 Nm)	On/Off, Floating	24 Vac/Vdc	0-10 kOhm	—	95	ML6174A2002 + 200976A	70 lb-in. (8 Nm)	On/Off, Floating	24 Vac (±20%)	500 Ohm	—	95
							ML6174A2002 + 200976C	—	On/Off, Floating	24 Vac (±20%)	2 kOhm	—	95
LMB24-3	45 lb-in. (5 Nm)	On/Off, Floating	24 Vac/Vdc	—	—	95	MN6105A1011	44 lb-in. (5 Nm)	On/Off, Floating	24 Vac/Vdc (+20 / -15%)	—	—	95
LMB24-3-T	45 lb-in. (5 Nm)	On/Off, Floating	24 Vac/Vdc	—	—	95	MN6105A1011	44 lb-in. (5 Nm)	On/Off, Floating	24 Vac/Vdc (+20 / -15%)	—	—	95
LMB24-3-S	45 lb-in. (5 Nm)	On/Off, Floating	24 Vac/Vdc	—	1 (0-95)	95	MN6105A1201	44 lb-in. (5 Nm)	On/Off, Floating	24 Vac/Vdc (+20 / -15%)	—	2 (5, 85)	95
LMB24-SR	45 lb-in. (5 Nm)	2-10 Vdc (4-20 mA)	24 Vac/Vdc	—	—	95	MN7505A2001	44 lb-in. (5 Nm)	On/Off, Floating, (0) 2-10 Vdc	24 Vac/Vdc (+20 / -15%)	(0) 2-10 Vdc	—	95
LMX24-SR	45 lb-in. (5 Nm)	2-10 Vdc (4-20 mA)	24 Vac/Vdc	2-10 Vdc	—	95 (selectable 35-150)	MN7505A2001	44 lb-in. (5 Nm)	On/Off, Floating, (0) 2-10 Vdc	24 Vac/Vdc (+20 / -15%)	(0) 2-10 Vdc	—	95
LMB24-SR-T	45 lb-in. (5 Nm)	2-10 Vdc (4-20 mA)	24 Vac/Vdc	—	—	95	MN7505A2001	44 lb-in. (5 Nm)	On/Off, Floating, (0) 2-10 Vdc	24 Vac/Vdc (+20 / -15%)	(0) 2-10 Vdc	—	95
LMX24-SR-T	45 lb-in. (5 Nm)	2-10 Vdc (4-20 mA)	24 Vac/Vdc	—	—	95 (selectable 35-150)	MN7505A2001	44 lb-in. (5 Nm)	On/Off, Floating, (0) 2-10 Vdc	24 Vac/Vdc (+20 / -15%)	(0) 2-10 Vdc	—	95
LMX24-MFT	45 lb-in. (5 Nm)	MFT	24 Vac/Vdc	Variable (0-10 Vdc)	—	150 (selectable 35-150)	MN7505A2001	44 lb-in. (5 Nm)	On/Off, Floating, (0) 2-10 Vdc	24 Vac/Vdc (+20 / -15%)	(0) 2-10 Vdc	—	95
LMX24-MFT	45 lb-in. (5 Nm)	MFT	24 Vac/Vdc	Variable (0-10 Vdc)	Add-On	150 (selectable 35-150)	MN7505A2209	44 lb-in. (5 Nm)	On/Off, Floating, (0) 2-10 Vdc	24 Vac/Vdc (+20 / -15%)	(0) 2-10 Vdc	2 (5, 85)	95
LMCB24-3	45 lb-in. (5 Nm)	On/Off, Floating	24 Vac/Vdc	—	—	35	MN6105A1011	44 lb-in. (5 Nm)	On/Off, Floating	24 Vac/Vdc (+20 / -15%)	—	—	95
LMCB24-3-T	45 lb-in. (5 Nm)	On/Off, Floating	24 Vac/Vdc	—	—	35	MN6105A1011	44 lb-in. (5 Nm)	On/Off, Floating	24 Vac/Vdc (+20 / -15%)	—	—	95
LMX24-3	45 lb-in. (5 Nm)	On/Off, Floating	24 Vac/Vdc	—	—	95 (selectable 35-150)	MN6105A1011	44 lb-in. (5 Nm)	On/Off, Floating	24 Vac/Vdc (+20 / -15%)	—	—	95
LMX24-3-T	45 lb-in. (5 Nm)	On/Off, Floating	24 Vac/Vdc	—	—	95 (selectable 35-150)	MN6105A1011	44 lb-in. (5 Nm)	On/Off, Floating	24 Vac/Vdc (+20 / -15%)	—	—	95
LMX120-3	45 lb-in. (5 Nm)	On/Off, Floating	100-240 Vac	—	—	95 (selectable 35-150)	—	—	—	—	—	—	—
LMCB24-SR	45 lb-in. (5 Nm)	2-10 Vdc (4-20 mA)	24 Vac/Vdc	2-10 Vdc	—	35	MN7505A2001	44 lb-in. (5 Nm)	On/Off, Floating, (0) 2-10 Vdc	24 Vac/Vdc (+20 / -15%)	(0) 2-10 Vdc	—	95
LMCB24-SR-T	45 lb-in. (5 Nm)	2-10 Vdc (4-20 mA)	24 Vac/Vdc	—	—	35	MN7505A2001	44 lb-in. (5 Nm)	On/Off, Floating, (0) 2-10 Vdc	24 Vac/Vdc (+20 / -15%)	(0) 2-10 Vdc	—	95
LMX120-SR	45 lb-in. (5 Nm)	2-10 Vdc (4-20 mA)	100-240 Vac	2-10 Vdc	—	95 (selectable 35-150)	MN7505A2001	44 lb-in. (5 Nm)	On/Off, Floating, (0) 2-10 Vdc	24 Vac/Vdc (+20 / -15%)	(0) 2-10 Vdc	—	95
LMX24-MFT95	45 lb-in. (5 Nm)	0-135 Ohm	24 Vac/Vdc	Variable (0-10 Vdc)	—	150 (selectable 35-150)	MN7505A2001 + Q7002B1009	44 lb-in. (5 Nm)	0-135 OHM	24 Vac/Vdc (+20 / -15%)	(0) 2-10 Vdc	—	95
LMX24-PC	45 lb-in. (5 Nm)	0-20 V Phase Cut	24 Vac/Vdc	2-10 Vdc	—	95	—	—	—	—	—	—	—
NMB24-3	90 lb-in. (10 Nm)	On/Off, Floating	24 Vac/Vdc	—	—	95	MN6110A1003	88 lb-in. (10 Nm)	On/Off, Floating	24 Vac/Vdc (+20 / -15%)	—	—	95
NMCB24-3	90 lb-in. (10 Nm)	On/Off, Floating	24 Vac/Vdc	—	—	45	MN6110A1003	88 lb-in. (10 Nm)	On/Off, Floating	24 Vac/Vdc (+20 / -15%)	—	—	95
NMX24-3	90 lb-in. (10 Nm)	On/Off, Floating	24 Vac/Vdc	—	—	95 (selectable 35-150)	MN6110A1003	88 lb-in. (10 Nm)	On/Off, Floating	24 Vac/Vdc (+20 / -15%)	—	—	95

Competitive Cross Reference

Direct Coupled Actuator

Belimo Model	Torque (lb-in.)	Control Signal	Power	Feedback	Switches	Timing (sec)	Honeywell Actuator	Torque (lb-in.)	Control Signal ^a	Power	Feedback ^a	Switches	Timing (sec)
NMCB24-3-T	90 lb-in. (10 Nm)	On/Off, Floating	24 Vac/Vdc	—	—	45	MN6110A1003	88 lb-in. (10 Nm)	On/Off, Floating	24 Vac/Vdc (+20 / -15%)	—	—	95
NMX24-3-T	90 lb-in. (10 Nm)	On/Off, Floating	24 Vac/Vdc	—	—	95 (selectable 35-150)	MN6110A1003	88 lb-in. (10 Nm)	On/Off, Floating	24 Vac/Vdc (+20 / -15%)	—	—	95
NMX120-3	90 lb-in. (10 Nm)	On/Off, Floating	100-240 Vac	—	—	95 (selectable 35-150)	—	—	—	—	—	—	—
NMB24-SR	90 lb-in. (10 Nm)	2-10 Vdc (4-20 mA)	24 Vac/Vdc	—	—	95	MN7510A2001	88 lb-in. (10 Nm)	On/Off, Floating, (0) 2-10 Vdc	24 Vac/Vdc (+20 / -15%)	(0) 2-10 Vdc	—	95
NMCB24-SR	90 lb-in. (10 Nm)	2-10 Vdc (4-20 mA)	24 Vac/Vdc	2-10 Vdc	—	45	MN7510A2001	88 lb-in. (10 Nm)	On/Off, Floating, (0) 2-10 Vdc	24 Vac/Vdc (+20 / -15%)	(0) 2-10 Vdc	—	95
NMX24-SR	90 lb-in. (10 Nm)	2-10 Vdc (4-20 mA)	24 Vac/Vdc	2-10 Vdc	—	95 (selectable 35-150)	MN7510A2001	88 lb-in. (10 Nm)	On/Off, Floating, (0) 2-10 Vdc	24 Vac/Vdc (+20 / -15%)	(0) 2-10 Vdc	—	95
NMCB24-SR-T	90 lb-in. (10 Nm)	2-10 Vdc (4-20 mA)	24 Vac/Vdc	—	—	45	MN7510A2001	88 lb-in. (10 Nm)	On/Off, Floating, (0) 2-10 Vdc	24 Vac/Vdc (+20 / -15%)	(0) 2-10 Vdc	—	95
NMX24-SR-T	90 lb-in. (10 Nm)	2-10 Vdc (4-20 mA)	24 Vac/Vdc	—	—	95 (selectable 35-150)	MN7510A2001	88 lb-in. (10 Nm)	On/Off, Floating, (0) 2-10 Vdc	24 Vac/Vdc (+20 / -15%)	(0) 2-10 Vdc	—	95
NMX120-SR	90 lb-in. (10 Nm)	2-10 Vdc (4-20 mA)	100-240 Vac	2-10 Vdc	—	95 (selectable 35-150)	—	—	—	—	—	—	—
NMX24-MFT	90 lb-in. (10 Nm)	MFT	24 Vac/Vdc	Variable (0-10 Vdc)	—	150 (selectable 35-150)	MN7510A2001	88 lb-in. (10 Nm)	On/Off, Floating, (0) 2-10 Vdc	24 Vac/Vdc (+20 / -15%)	(0) 2-10 Vdc	—	95
NMX24-MFT95	90 lb-in. (10 Nm)	0-135 Ohm	24 Vac/Vdc	Variable (0-10 Vdc)	—	150 (selectable 45-170)	MN7510A2001 + Q7002B1009	88 lb-in. (10 Nm)	0-135 OHM	24 Vac/Vdc (+20 / -15%)	(0) 2-10 Vdc	—	95
NMX24-PC	90 lb-in. (10 Nm)	0-20 Vdc Phase Cut	24 Vac/Vdc	2-10 Vdc	—	95	—	—	—	—	—	—	—
NMQ24-MFT US	90 lb-in. (10 Nm)	MFT	24 Vac/Vdc	—	—	150	MN7510A2001	88 lb-in. (10 Nm)	On/Off, Floating, (0) 2-10 Vdc	24 Vac/Vdc (+20 / -15%)	(0) 2-10 Vdc	—	95
NMB24-3+S2A	90 lb-in. (10 Nm)	On/Off, Floating	24 Vac/Vdc	—	2 (adj 0-95)	95	MN6110A1201	88 lb-in. (10 Nm)	On/Off, Floating	24 Vac/Vdc (+20 / -15%)	—	2 (5, 85)	95
NMB24-SR + S2A	90 lb-in. (10 Nm)	2-10 Vdc (4-20 mA)	24 Vac/Vdc	—	2 (adj 0-95)	95	MN7510A2209	88 lb-in. (10 Nm)	On/Off, Floating, (0) 2-10 Vdc	24 Vac/Vdc (+20 / -15%)	(0) 2-10 Vdc	2 (5, 85)	95
AMB24-3	180 lb-in. (20 Nm)	On/Off, Floating	24 Vac/Vdc	—	—	95	MN6120A1002	175 lb-in. (20 Nm)	On/Off, Floating	24 Vac (±15%), 24 Vdc	—	—	95
AMX24-3	180 lb-in. (20 Nm)	On/Off, Floating	24 Vac/Vdc	—	—	95 (selectable 95-300)	MN6120A1002	175 lb-in. (20 Nm)	On/Off, Floating	24 Vac (±15%), 24 Vdc	—	—	95
AMX24-3-T	180 lb-in. (20 Nm)	On/Off, Floating	24 Vac/Vdc	—	—	95 (selectable 95-300)	MN6120A1002	175 lb-in. (20 Nm)	On/Off, Floating	24 Vac (±15%), 24 Vdc	—	—	95
AMB24-3-S	180 lb-in. (20 Nm)	On/Off, Floating	24 Vac/Vdc	—	1 (adj 0-95)	95	MN6120A1200	175 lb-in. (20 Nm)	On/Off, Floating	24 Vac (±15%), 24 Vdc	—	2 (5, 85)	95
AMX120-3	180 lb-in. (20 Nm)	On/Off, Floating	100-240 Vac	—	—	95 (selectable 95-300)	—	—	—	—	—	—	—
AMB24-SR	180 lb-in. (20 Nm)	2-10 Vdc (4-20 mA)	24 Vac/Vdc	2-10 Vdc	—	95	MN7220A2007	175 lb-in. (20 Nm)	(0) 2-10 Vdc, (0) 4-20 mA	24 Vac (±20%), 24 Vdc	(0) 2-10 Vdc	—	95
AMX24-SR	180 lb-in. (20 Nm)	2-10 Vdc (4-20 mA)	24 Vac/Vdc	2-10 Vdc	—	95 (selectable 95-300)	MN7220A2007	175 lb-in. (20 Nm)	(0) 2-10 Vdc, (0) 4-20 mA	24 Vac (±20%), 24 Vdc	(0) 2-10 Vdc	—	95
AMX24-SR-T	180 lb-in. (20 Nm)	2-10 Vdc (4-20 mA)	24 Vac/Vdc	—	—	95 (selectable 95-300)	MN7220A2007	175 lb-in. (20 Nm)	(0) 2-10 Vdc, (0) 4-20 mA	24 Vac (±20%), 24 Vdc	(0) 2-10 Vdc	—	95
AMB24-SR+S2A	180 lb-in. (20 Nm)	2-10 Vdc (4-20 mA)	24 Vac/Vdc	2-10 Vdc	2 (adj 0-95)	95	MN7220A2205	175 lb-in. (20 Nm)	(0) 2-10 Vdc, (0) 4-20 mA	24 Vac (±20%), 24 Vdc	(0) 2-10 Vdc	2 (5, 85)	95
AMX120-SR	180 lb-in. (20 Nm)	2-10 Vdc (4-20 mA)	100-240 Vac	2-10 Vdc	—	95 (selectable 95-300)	—	—	—	—	—	—	—

Competitive Cross Reference

Direct Coupled Actuator

Belimo Model	Torque (lb-in.)	Control Signal	Power	Feedback	Switches	Timing (sec)	Honeywell Actuator	Torque (lb-in.)	Control Signal ^a	Power	Feedback ^a	Switches	Timing (sec)
AMX24-MFT	180 lb-in. (20 Nm)	MFT	24 Vac/Vdc	Variable (0-10 Vdc)	—	150 (selectable 95-300)	MN7220A2007	175 lb-in. (20 Nm)	(0) 2-10 Vdc, (0) 4-20 mA	24 Vac (±20%), 24 Vdc	(0) 2-10 Vdc	—	95
AMX24-MFT95	180 lb-in. (20 Nm)	0-135 Ohm	24 Vac/Vdc	Variable (0-10 Vdc)	—	150 (selectable 95-300)	MN7220A2007+Q7002B1009	175 lb-in. (20 Nm)	0-135 OHM	24 Vac (±20%), 24 Vdc	(0) 2-10 Vdc	—	95
AMX24-PC	180 lb-in. (20 Nm)	0-20 Vdc Phase Cut	24 Vac/Vdc	2-10 Vdc	—	150 (selectable 95-300)	—	—	—	—	—	—	—
GMB24-3	360 lb-in. (40 Nm)	On/Off, Floating	24 Vac/Vdc	—	—	150	MN6134A1003	300 lb-in. (34 Nm)	On/Off, Floating	24 Vac (±15%), 24 Vdc	—	—	95
GMX24-3	360 lb-in. (40 Nm)	On/Off, Floating	24 Vac/Vdc	—	—	150	MN6134A1003	300 lb-in. (34 Nm)	On/Off, Floating	24 Vac (±15%), 24 Vdc	—	—	95
GMX120-3	360 lb-in. (40 Nm)	On/Off, Floating	100-240 Vac	—	—	150	—	—	—	—	—	—	—
GMB24-SR	360 lb-in. (40 Nm)	2-10 Vd (4-20 mA)	24 Vac/Vdc	2-10 Vdc	—	150	MN7234A2008	300 lb-in. (34 Nm)	(0) 2-10 Vdc, (0) 4-20 mA	24 Vac (±20%), 24 Vdc	(0) 2-10 Vdc	—	95
GMX24-SR	360 lb-in. (40 Nm)	2-10 Vdc (4-20 mA)	24 Vac/Vdc	2-10 Vdc	—	150	MN7234A2008	300 lb-in. (34 Nm)	(0) 2-10 Vdc, (0) 4-20 mA	24 Vac (±20%), 24 Vdc	(0) 2-10 Vdc	—	95
GMX24-MFT	360 lb-in. (40 Nm)	MFT	24 Vac/Vdc	Variable (0-10 Vdc)	—	150 (selectable 70-300)	MN7234A2008	300 lb-in. (34 Nm)	(0) 2-10 Vdc, (0) 4-20 mA	24 Vac (±20%), 24 Vdc	(0) 2-10 Vdc	—	95
GMX24-MFT95	360 lb-in. (40 Nm)	0-135 Ohm	24 Vac/Vdc	Variable (0-10 Vdc)	—	150 (selectable 70-300)	MN7234A2008 + Q7002B1009	300 lb-in. (34 Nm)	0-135 OHM	24 Vac (±20%), 24 Vdc	(0) 2-10 Vdc	—	95
GMX24-PC	360 lb-in. (40 Nm)	0-20 Vdc Phase Cut	24 Vac/Vdc	2-10 Vdc	—	150 (selectable 70-300)	—	—	—	—	—	—	—
LF24 US	35 lb-in. (5 Nm)	On/Off	24 Vac/Vdc	—	—	40-75	MS8105A1030	44 lb-in. (5 Nm)	On/Off	24 Vac (±20%), 24 Vdc	—	—	45
LF24-S US	35 lb-in. (5 Nm)	On/Off	24 Vac/Vdc	—	1 (adj 0-95)	40-75	MS8105A1130	44 lb-in. (5 Nm)	On/Off	24 Vac (±20%), 24 Vdc	—	1 (Adjustable)	45
LF120 US	35 lb-in. (5 Nm)	On/Off	120 Vac	—	—	40-75	MS4105A1030	44 lb-in. (5 Nm)	On/Off	100-250 Vac	—	—	45
LF120-S US	35 lb-in. (5 Nm)	On/Off	120 Vac	—	1 (adj 0-95)	40-75	MS4105A1130	44 lb-in. (5 Nm)	On/Off	100-250 Vac	—	1 (Adjustable)	45
LF230 US	35 lb-in. (5 Nm)	On/Off	230 Vac	—	—	40-75	MS4105A1030	44 lb-in. (5 Nm)	On/Off	100-250 Vac	—	—	45
LF230-S US	35 lb-in. (5 Nm)	On/Off	230 Vac	—	1 (adj 0-95)	40-75	MS4105A1130	44 lb-in. (5 Nm)	On/Off	100-250 Vac	—	1 (Adjustable)	45
LF24-3 US	35 lb-in. (5 Nm)	Modulating	24 Vac/Vdc	—	—	150	MS7505A2030	44 lb-in. (5 Nm)	On/Off, Floating, (0) 2-10 Vdc	24 Vac (±20%), 24 Vdc	(0) 2-10 Vdc	—	90
LF24-3-S US	35 lb-in. (5 Nm)	Modulating	24 Vac/Vdc	—	1 (adj 0-95)	150	MS7505A2130	44 lb-in. (5 Nm)	On/Off, Floating, (0) 2-10 Vdc	24 Vac (±20%), 24 Vdc	(0) 2-10 Vdc	1 (Adjustable)	90
LFC24-3-R US	35 lb-in. (5 Nm)	Floating	24 Vac/Vdc	—	—	90	MS7505A2030	44 lb-in. (5 Nm)	On/Off, Floating, (0) 2-10 Vdc	24 Vac (±20%), 24 Vdc	(0) 2-10 Vdc	—	90
LFC24-3-S US	35 lb-in. (5 Nm)	Floating	24 Vac/Vdc	—	1 (adj 0-95)	90	MS7505A2130	44 lb-in. (5 Nm)	On/Off, Floating, (0) 2-10 Vdc	24 Vac (±20%), 24 Vdc	(0) 2-10 Vdc	1 (Adjustable)	90
LF24-SR US	35 lb-in. (5 Nm)	2-10 Vdc (4-20 mA)	24 Vac/Vdc	2-10 Vdc	—	150	MS7505A2030	44 lb-in. (5 Nm)	On/Off, Floating, (0) 2-10 Vdc	24 Vac (±20%), 24 Vdc	(0) 2-10 Vdc	—	90
LF24-SR-S US	35 lb-in. (5 Nm)	2-10 Vdc (4-20 mA)	24 Vac/Vdc	2-10 Vdc	1 (adj 0-95)	150	MS7505A2130	44 lb-in. (5 Nm)	On/Off, Floating, (0) 2-10 Vdc	24 Vac (±20%), 24 Vdc	(0) 2-10 Vdc	1 (Adjustable)	90
LF24-SR-E US	35 lb-in. (5 Nm)	2-10 Vdc, Built-in minimum position	24 Vac/Vdc	2-10 Vdc	—	150	MS7405A2030	44 lb-in. (5 Nm)	On/Off, Floating, (0) 2-10 Vdc, Economizer (3kOhm, 3-Position)	24 Vac (±20%), 24 Vdc	(0) 2-10 Vdc	—	90

Competitive Cross Reference

Direct Coupled Actuator

Belimo Model	Torque (lb-in.)	Control Signal	Power	Feedback	Switches	Timing (sec)	Honeywell Actuator	Torque (lb-in.)	Control Signal ^a	Power	Feedback ^a	Switches	Timing (sec)
LF24-ECON-R03 US	35 lb-in. (5 Nm)	0-3 kOhm, type 10 thermistor	24 Vac/Vdc	2-10 Vdc	—	95	MS7405A2030	44 lb-in. (5 Nm)	On/Off, Floating, (0) 2-10 Vdc, Economizer (3kOhm, 3-Position)	24 Vac (±20%), 24 Vdc	(0) 2-10 Vdc	—	90
LF24-ECON-R10 US	35 lb-in. (5 Nm)	0-10 kOhm, type 7 thermistor	24 Vac/Vdc	2-10 Vdc	—	95	—	—	—	—	—	—	—
LF24-MFT US	35 lb-in. (5 Nm)	MFT	24 Vac/Vdc	2-10 Vdc	—	150	MS7505A2030	44 lb-in. (5 Nm)	On/Off, Floating, (0) 2-10 Vdc	24 Vac (±20%), 24 Vdc	(0) 2-10 Vdc	—	90
LF24-MFT-S US	35 lb-in. (5 Nm)	MFT	24 Vac/Vdc	2-10 Vdc	1 (adj 0-95)	150	MS7505A2130	44 lb-in. (5 Nm)	On/Off, Floating, (0) 2-10 Vdc	24 Vac (±20%), 24 Vdc	(0) 2-10 Vdc	1 (Adjustable)	90
LF24-MFT-20 US	35 lb-in. (5 Nm)	MFT	24 Vac/Vdc	2-10 Vdc	—	150	MS7505A2030	44 lb-in. (5 Nm)	On/Off, Floating, (0) 2-10 Vdc	24 Vac (±20%), 24 Vdc	(0) 2-10 Vdc	—	90
LF24-MFT-20-S US	35 lb-in. (5 Nm)	MFT	24 Vac/Vdc	2-10 Vdc	1 (adj 0-95)	150	MS7505A2130	44 lb-in. (5 Nm)	On/Off, Floating, (0) 2-10 Vdc	24 Vac (±20%), 24 Vdc	(0) 2-10 Vdc	1 (Adjustable)	90
NF24 US	60 lb-in. (7 Nm)	On/Off	24 Vac/Vdc	—	—	< 75	MS8110A1008	88 lb-in. (10 Nm)	On/Off	24 Vac (±20%), 24 Vdc	—	—	45
NF24-S US	60 lb-in. (7 Nm)	On/Off	24 Vac/Vdc	—	1 (adj 5-85)	< 75	MS8110A1206	88 lb-in. (10 Nm)	On/Off	24 Vac (±20%), 24 Vdc	—	2 (7, 85)	45
NF24-S2 US	60 lb-in. (7 Nm)	On/Off	24 Vac/Vdc	—	2 (5, and adj 25-85)	< 75	MS8110A1206	88 lb-in. (10 Nm)	On/Off	24 Vac (±20%), 24 Vdc	—	2 (7, 85)	45
NF120 US	60 lb-in. (7 Nm)	On/Off	120 Vac	—	—	< 75	MS4110A1002	88 lb-in. (10 Nm)	On/Off	100-250 Vac	—	—	45
NF120-S US	60 lb-in. (7 Nm)	On/Off	120 Vac	—	1 (adj 5-85)	< 75	MS4110A1200	88 lb-in. (10 Nm)	On/Off	100-250 Vac	—	2 (7, 85)	45
NF24-SR US	60 lb-in. (7 Nm)	2-10 Vdc (4-20 mA)	24 Vac/Vdc	2-10 Vdc	—	150	MS7510A2008	88 lb-in. (10 Nm)	On/Off, Floating, (0) 2-10 Vdc	24 Vac (±20%), 24 Vdc	(0) 2-10 Vdc	—	90
NF24-SR-S US	60 lb-in. (7 Nm)	2-10 Vdc (4-20 mA)	24 Vac/Vdc	2-10 Vdc	1 (adj 5-85)	150	MS7510A2206	88 lb-in. (10 Nm)	On/Off, Floating, (0) 2-10 Vdc	24 Vac (±20%), 24 Vdc	(0) 2-10 Vdc	2 (7, 85)	90
NF24-MFT US	60 lb-in. (7 Nm)	MFT	24 Vac/Vdc	—	—	150	MS7510A2008	88 lb-in. (10 Nm)	On/Off, Floating, (0) 2-10 Vdc	24 Vac (±20%), 24 Vdc	(0) 2-10 Vdc	—	90
AF24 US	133 lb-in. (15 Nm)	On/Off	24 Vac/Vdc	—	—	150	MS8120A1007	175 lb-in. (20 Nm)	On/Off	24 Vac (±20%), 24 Vdc	—	—	45
AF24-S US	133 lb-in. (15 Nm)	On/Off	24 Vac/Vdc	—	2 (5, and adj 25-85)	150	MS8120A1205	175 lb-in. (20 Nm)	On/Off	24 Vac (±20%), 24 Vdc	—	2 (7, 85)	45
AF120 US	133 lb-in. (15 Nm)	On/Off	120 Vac	—	—	150	MS4120A1001	175 lb-in. (20 Nm)	On/Off	100-250 Vac	—	—	45
AF120-S US	133 lb-in. (15 Nm)	On/Off	120 Vac	—	2 (5, and adj 25-85)	150	MS4120A1209	175 lb-in. (20 Nm)	On/Off	100-250 Vac	—	2 (7, 85)	45
AF230 US	133 lb-in. (15 Nm)	On/Off	230 Vac	—	—	150	MS4120A1001	175 lb-in. (20 Nm)	On/Off	100-250 Vac	—	—	45
AF230-S US	133 lb-in. (15 Nm)	On/Off	230 Vac	—	2 (5, and adj 25-85)	150	MS4120A1209	175 lb-in. (20 Nm)	On/Off	100-250 Vac	—	2 (7, 85)	45
AF24-SR US	133 lb-in. (15 Nm)	2-10 Vdc (4-20 mA)	24 Vac/Vdc	2-10 Vdc	—	150	MS7520A2007	175 lb-in. (20 Nm)	On/Off, Floating, (0) 2-10 Vdc	24 Vac (±20%), 24 Vdc	(0) 2-10 Vdc	—	90
AF24-MFT US	133 lb-in. (15 Nm)	MFT	24 Vac/Vdc	2-10 Vdc	—	150	MS7520A2007	175 lb-in. (20 Nm)	On/Off, Floating, (0) 2-10 Vdc	24 Vac (±20%), 24 Vdc	(0) 2-10 Vdc	—	90
AF24-MFT-S US	133 lb-in. (15 Nm)	MFT	24 Vac/Vdc	2-10 Vdc	2 (5, and adj 25-85)	150	MS7520A2205	175 lb-in. (20 Nm)	On/Off, Floating, (0) 2-10 Vdc	24 Vac (±20%), 24 Vdc	(0) 2-10 Vdc	2 (7, 85)	90
AF24-MFT-S US	133 lb-in. (15 Nm)	MFT	24 Vac/Vdc	2-10 Vdc	2 (5, and adj 25-85)	150	MS7520H2208	175 lb-in. (20 Nm)	On/Off, Floating, (0) 2-10 Vdc	24 Vac (±20%), 24 Vdc	(0) 2-10 Vdc	2 (7, 85)	90
AF24-MFT95 US	133 lb-in. (15 Nm)	0-135 Ohm	24 Vac/Vdc	—	—	150	MS7520A2007 + Q7002B1009	175 lb-in. (20 Nm)	0-135 ohm	24 Vac (±20%), 24 Vdc	(0) 2-10 Vdc	—	90

Competitive Cross Reference

Direct Coupled Actuator

Belimo Model	Torque (lb-in.)	Control Signal	Power	Feedback	Switches	Timing (sec)	Honeywell Actuator	Torque (lb-in.)	Control Signal ^a	Power	Feedback ^a	Switches	Timing (sec)
TF24 US	18 lb-in. (2 Nm)	On/Off	24 Vac/Vdc	—	—	<75	MS8103A1030	27 lb-in. (3 Nm)	On/Off	24 Vac (±20%), 24 Vdc	—	—	45
TF24-S US	18 lb-in. (2 Nm)	On/Off	24 Vac/Vdc	—	1 (adj 0-95)	<75	MS8103A1130	27 lb-in. (3 Nm)	On/Off	24 Vac (±20%), 24 Vdc	—	1 (Adjustable)	45
TF120 US	18 lb-in. (2 Nm)	On/Off	100-240 Vac	—	—	<75	MS4103A1030	27 lb-in. (3 Nm)	On/Off	100-250 Vac	—	—	45
TF120-S US	18 lb-in. (2 Nm)	On/Off	100-240 Vac	—	1 (adj 0-95)	<75	MS4103A1130	27 lb-in. (3 Nm)	On/Off	100-250 Vac	—	1 (Adjustable)	45
TF24-SR US	18 lb-in. (2 Nm)	2-10 Vdc (4-20 mA)	24 Vac/Vdc	—	—	95	MS7503A2030	27 lb-in. (3 Nm)	On/Off, Floating, (0) 2-10 Vdc	24 Vac (±20%), 24 Vdc	(0) 2-10 Vdc	—	90
TF24-SR-S US	18 lb-in. (2 Nm)	2-10 Vdc (4-20 mA)	24 Vac/Vdc	—	1 (adj 0-95)	95	MS7503A2130	27 lb-in. (3 Nm)	On/Off, Floating, (0) 2-10 Vdc	24 Vac (±20%), 24 Vdc	(0) 2-10 Vdc	1 (Adjustable)	90
TF24-3 US	18 lb-in. (2 Nm)	Floating	24 Vac/Vdc	—	—	95	MS7503A2030	27 lb-in. (3 Nm)	On/Off, Floating, (0) 2-10 Vdc	24 Vac (±20%), 24 Vdc	(0) 2-10 Vdc	—	90
TF24-3-S US	18 lb-in. (2 Nm)	Floating	24 Vac/Vdc	—	1 (adj 0-95)	95	MS7503A2130	27 lb-in. (3 Nm)	On/Off, Floating, (0) 2-10 Vdc	24 Vac (±20%), 24 Vdc	(0) 2-10 Vdc	1 (Adjustable)	90

^a All models described as (0) 2-10 Vdc can be used with a 4-20 mA control input. Shunt a 500 ohm, 1/2 W resistor across the input at the actuator.

Johnson Model	Torque (lb-in.)	Control Signal	Power	Feedback	Switches	Timing (sec)	Honeywell Actuator	Torque (lb-in.)	Control Signal ^a	Power	Feedback ^a	Switches	Timing (sec)
M9104-AGA-2N	35 lb-in. (4 Nm)	Floating	20 to 30 Vac at 50/60 Hz	—	—	90 / 108 (at 60 / 50 Hz)	MN6105A1011	44 lb-in. (5 Nm)	On/Off, Floating	24 Vac/Vdc (+20 / -15%)	—	—	95
M9104-AGS-2N	35 lb-in. (4 Nm)	Floating	20 to 30 Vac at 50/60 Hz	—	—	90 / 108 (at 60 / 50 Hz)	MN6105A1011	44 lb-in. (5 Nm)	On/Off, Floating	24 Vac/Vdc (+20 / -15%)	—	—	95
M9106-IGA-2	53 lb-in. (6 Nm) and 35 lb-in. (4 Nm)	On/Off, Floating	20 to 30 Vac at 50/60 Hz	—	—	Selectable: 60, 90, 120, 330, or 660 (at 60 Hz). 72, 108, 144, 396, or 792 (at 50 Hz).	MN6105A1011	44 lb-in. (5 Nm)	On/Off, Floating	24 Vac/Vdc (+20 / -15%)	—	—	95
M9106-IGC-2	53 lb-in. (6 Nm) and 35 lb-in. (4 Nm)	On/Off, Floating	20 to 30 Vac at 50/60 Hz	—	2	Selectable: 60, 90, 120, 330, or 660 (at 60 Hz). 72, 108, 144, 396, or 792 (at 50 Hz).	MN6105A1201	44 lb-in. (5 Nm)	On/Off, Floating	24 Vac/Vdc (+20 / -15%)	—	2 (5, 85)	95
M9106-AGA-2	53 lb-in. (6 Nm)	Floating	20 to 30 Vac at 50/60 Hz	—	—	60 / 72 (at 60 / 50 Hz)	MN6110A1003	88 lb-in. (10 Nm)	On/Off, Floating	24 Vac/Vdc (+20 / -15%)	—	—	95
M9106-AGA-2N01	53 lb-in. (6 Nm)	Floating	20 to 30 Vac at 50/60 Hz	—	—	60 / 72 (at 60 / 50 Hz)	MN6110A1003	88 lb-in. (10 Nm)	On/Off, Floating	24 Vac/Vdc (+20 / -15%)	—	—	95
M9106-AGA-2N02	53 lb-in. (6 Nm)	Floating	20 to 30 Vac at 50/60 Hz	—	—	120 / 144 (at 60 / 50 Hz)	MN6110A1003	88 lb-in. (10 Nm)	On/Off, Floating	24 Vac/Vdc (+20 / -15%)	—	—	95
M9106-AGC-2	53 lb-in. (6 Nm)	Floating	20 to 30 Vac at 50/60 Hz	—	2	60 / 72 (at 60 / 50 Hz)	MN6110A1201	88 lb-in. (10 Nm)	On/Off, Floating	24 Vac/Vdc (+20 / -15%)	—	2 (5, 85)	95
M9106-AGF-2	53 lb-in. (6 Nm)	Floating	20 to 30 Vac at 50/60 Hz	0-10 kOhm	—	60 / 72 (at 60 / 50 Hz)	ML6174B2019 + 200976C	70 lb-in. (8 Nm)	On/Off, Floating	24 Vac	0-2 kOhm	—	95
M9106-AGS-2N02	53 lb-in. (6 Nm)	Floating	20 to 30 Vac at 50/60 Hz	—	—	120 / 144 (at 60 / 50 Hz)	MN6110A1003	88 lb-in. (10 Nm)	On/Off, Floating	24 Vac/Vdc (+20 / -15%)	—	—	95
M9106-GGA-2	53 lb-in. (6 Nm)	(0) 2-10 Vdc, (0) 4 to 20 mA	20 to 30 Vac at 50/60 Hz	(0) 2-10 Vdc for 90 (1 mA at 10 Vdc). Corresponds to span selection.	—	60 / 72 (at 60 / 50 Hz)	MN7510A2001	88 lb-in. (10 Nm)	On/Off, Floating, (0) 2-10 Vdc	24 Vac/Vdc (+20 / -15%)	(0) 2-10 Vdc	—	95

Competitive Cross Reference

Direct Coupled Actuator

Johnson Model	Torque (lb-in.)	Control Signal	Power	Feedback	Switches	Timing (sec)	Honeywell Actuator	Torque (lb-in.)	Control Signal ^a	Power	Feedback ^a	Switches	Timing (sec)
M9106-GGC-2	53 lb-in. (6 Nm)	(0) 2-10 Vdc, (0) 4 to 20 mA	20 to 30 Vac at 50/60 Hz	(0) 2-10 Vdc for 90 (1 mA at 10 Vdc). Corresponds to span selection.	2	60 / 72 (at 60 / 50 Hz)	MN7510A2209	88 lb-in. (10 Nm)	On/Off, Floating, (0) 2-10 Vdc	24 Vac/ Vdc (+20 / -15%)	(0) 2-10 Vdc	2 (5, 85)	95
M9108-AGA-2	70 lb-in. (8 Nm)	On/Off, Floating	20 to 30 Vac at 50/60 Hz	—	—	25-50 for 0-70 lb-in. (0-8 Nm), 30 at 50% load.	MN6110A1003	88 lb-in. (10 Nm)	On/Off, Floating	24 Vac/ Vdc (+20 / -15%)	—	—	95
M9108-AGC-2	70 lb-in. (8 Nm)	On/Off, Floating	20 to 30 Vac at 50/60 Hz	—	2	25-50 for 0-70 lb-in. (0-8 Nm), 30 at 50% load.	MN6110A1201	88 lb-in. (10 Nm)	On/Off, Floating	24 Vac/ Vdc (+20 / -15%)	—	2 (5, 85)	95
M9108-AGD-2	70 lb-in. (8 Nm)	On/Off, Floating	20 to 30 Vac at 50/60 Hz	0-135 Ohm	—	25-50 for 0-70 lb-in. (0-8 Nm), 30 at 50% load.	ML6174B2019 + 200976A	70 lb-in. (8 Nm)	On/Off, Floating	24 Vac	0-500 Ohm	—	95
M9108-AGE-2	70 lb-in. (8 Nm)	On/Off, Floating	20 to 30 Vac at 50/60 Hz	0-1 kOhm	—	25-50 for 0-70 lb-in. (0-8 Nm), 30 at 50% load.	ML6174B2019 + 200976C	70 lb-in. (8 Nm)	On/Off, Floating	24 Vac	0-2 kOhm	—	95
M9108-GGA-2	70 lb-in. (8 Nm)	0-20 Vdc (selectable zero and span), (0) 4 to 20 mA, Reversible.	20 to 30 Vac at 50/60 Hz	(0) 2-10 Vdc for 90 (1 mA at 10 Vdc). Corresponds to span selection.	—	25-50 for 0-70 lb-in. (0-8 Nm), 30 at 50% load.	MN7510A2001	88 lb-in. (10 Nm)	On/Off, Floating, (0) 2-10 Vdc	24 Vac/ Vdc (+20 / -15%)	(0) 2-10 Vdc	—	95
M9108-GGC-2	70 lb-in. (8 Nm)	0-20 Vdc (selectable zero and span), (0) 4 to 20 mA, Reversible.	20 to 30 Vac at 50/60 Hz	(0) 2-10 Vdc for 90 (1 mA at 10 Vdc). Corresponds to span selection.	2	25-50 for 0-70 lb-in. (0-8 Nm), 30 at 50% load.	MN7510A2209	88 lb-in. (10 Nm)	On/Off, Floating, (0) 2-10 Vdc	24 Vac/ Vdc (+20 / -15%)	(0) 2-10 Vdc	2 (5, 85)	95
M9108-HGA-2	70 lb-in. (8 Nm)	0-20 Vdc (adjustable zero and span), (0) 4 to 20 mA, Reversible.	20 to 30 Vac at 50/60 Hz	(0) 2-10 Vdc for 90 (1 mA at 10 Vdc). Corresponds to span selection.	—	25-50 for 0-70 lb-in. (0-8 Nm), 30 at 50% load.	MN7510A2001	88 lb-in. (10 Nm)	On/Off, Floating, (0) 2-10 Vdc	24 Vac/ Vdc (+20 / -15%)	(0) 2-10 Vdc	—	95
M9108-HGC-2	70 lb-in. (8 Nm)	0-20 Vdc (adjustable zero and span), (0) 4 to 20 mA, Reversible.	20 to 30 Vac at 50/60 Hz	(0) 2-10 Vdc for 90 (1 mA at 10 Vdc). Corresponds to span selection.	2	25-50 for 0-70 lb-in. (0-8 Nm), 30 at 50% load.	MN7510A2209	88 lb-in. (10 Nm)	On/Off, Floating, (0) 2-10 Vdc	24 Vac/ Vdc (+20 / -15%)	(0) 2-10 Vdc	2 (5, 85)	95
M9108-JGA-2	70 lb-in. (8 Nm)	100-10 kOhms. Reversible.	20 to 30 Vac at 50/60 Hz	0-10 Vdc	—	25-50 for 0-70 lb-in. (0-8 Nm), 30 at 50% load.	—	—	—	—	—	—	—
M9108-JGC-2	70 lb-in. (8 Nm)	100-10 kOhms. Reversible.	20 to 30 Vac at 50/60 Hz	0-10 Vdc	2	25-50 for 0-70 lb-in. (0-8 Nm), 30 at 50% load..	—	—	—	—	—	—	—
M9109-AGA-2	80 lb-in. (9 Nm)	Floating	20 to 30 Vac at 50/60 Hz	—	—	60 / 72 (at 60 / 50 Hz)	MN6110A1003	88 lb-in. (10 Nm)	On/Off, Floating	24 Vac/ Vdc (+20 / -15%)	—	—	95
M9109-AGC-2	80 lb-in. (9 Nm)	Floating	20 to 30 Vac at 50/60 Hz	—	2	60 / 72 (at 60 / 50 Hz)	MN6110A1201	88 lb-in. (10 Nm)	On/Off, Floating	24 Vac/ Vdc (+20 / -15%)	—	2 (5, 85)	95
M9109-GGA-2	80 lb-in. (9 Nm)	(0) 2-10 Vdc, (0) 4-20 mA, Reversible	20 to 30 Vac at 50/60 Hz	(0) 2-10 Vdc for 90 (1 mA at 10 Vdc). Corresponds to span selection.	—	60 / 72 (at 60 / 50 Hz)	MN7510A2001	88 lb-in. (10 Nm)	On/Off, Floating, (0) 2-10 Vdc	24 Vac/ Vdc (+20 / -15%)	(0) 2-10 Vdc	—	95

Competitive Cross Reference

Direct Coupled Actuator

Johnson Model	Torque (lb-in.)	Control Signal	Power	Feedback	Switches	Timing (sec)	Honeywell Actuator	Torque (lb-in.)	Control Signal ^a	Power	Feedback ^a	Switches	Timing (sec)
M9109-GGC-2	80 lb-in. (9 Nm)	(0) 2-10 Vdc, (0) 4-20 mA, Reversible	20 to 30 Vac at 50/60 Hz	(0) 2-10 Vdc for 90 (1 mA at 10 Vdc). Corresponds to span selection.	2	60 / 72 (at 60 / 50 Hz)	MN7510A2209	88 lb-in. (10 Nm)	On/Off, Floating, (0) 2-10 Vdc	24 Vac/ Vdc (+20 / -15%)	(0) 2-10 Vdc	2 (5, 85)	95
M9116-AGA-2	140 lb-in. (16 Nm)	On/Off, Floating	20 to 30 Vac at 50/60 Hz	—	—	70-115 for 0-140 lb-in. (0-16 Nm). 80 at 50% load.	MN6120A1002	175 lb-in. (20 Nm)	On/Off, Floating	24 Vac (±15%), 24 Vdc	—	—	95
M9116-AGC-2	140 lb-in. (16 Nm)	On/Off, Floating	20 to 30 Vac at 50/60 Hz	—	2	70-115 for 0-140 lb-in. (0-16 Nm). 80 at 50% load.	MN6120A1200	175 lb-in. (20 Nm)	On/Off, Floating	24 Vac (±15%), 24 Vdc	—	2 (5, 85)	95
M9116-AGD-2	140 lb-in. (16 Nm)	On/Off, Floating	20 to 30 Vac at 50/60 Hz	0-135 Ohm	—	70-115 for 0-140 lb-in. (0-16 Nm). 80 at 50% load.	MN6120A1002	175 lb-in. (20 Nm)	On/Off, Floating	24 Vac (±15%), 24 Vdc	—	—	95
M9116-AGE-2	140 lb-in. (16 Nm)	On/Off, Floating	20 to 30 Vac at 50/60 Hz	0-1 kOhm	—	70-115 for 0-140 lb-in. (0-16 Nm). 80 at 50% load.	MN6120A1002	175 lb-in. (20 Nm)	On/Off, Floating	24 Vac (±15%), 24 Vdc	—	—	95
M9116-GGA-2	140 lb-in. (16 Nm)	(0) 2-10 Vdc, (0) 4-20 mA, Reversible	20 to 30 Vac at 50/60 Hz	(0) 2-10 Vdc for 90 (1 mA at 10 Vdc). Corresponds to span selection.	—	70-115 for 0-140 lb-in. (0-16 Nm). 80 at 50% load.	MN7220A2007	175 lb-in. (20 Nm)	(0) 2-10 Vdc, (0) 4-20 mA	24 Vac (±20%), 24 Vdc	(0) 2-10 Vdc	—	95
M9116-GGC-2	140 lb-in. (16 Nm)	(0) 2-10 Vdc, (0) 4-20 mA, Reversible	20 to 30 Vac at 50/60 Hz	(0) 2-10 Vdc for 90 (1 mA at 10 Vdc). Corresponds to span selection.	2	70-115 for 0-140 lb-in. (0-16 Nm). 80 at 50% load.	MN7220A2205	175 lb-in. (20 Nm)	(0) 2-10 Vdc, (0) 4-20 mA	24 Vac (±20%), 24 Vdc	(0) 2-10 Vdc	2 (5, 85)	95
M9116-HGA-2	140 lb-in. (16 Nm) & 280 lb-in. (32 Nm)	(0) 2-10 Vdc, (0) 4-20 mA, Reversible	20 to 30 Vac at 50/60 Hz	(0) 2-10 Vdc for 90 (1 mA at 10 Vdc). Corresponds to span selection.	—	70-115 for 0-140 lb-in. (0-16 Nm). 80 at 50% load.	MN7220A2007	175 lb-in. (20 Nm)	(0) 2-10 Vdc, (0) 4-20 mA	24 Vac (±20%), 24 Vdc	(0) 2-10 Vdc	—	95
M9116-HGC-2	140 lb-in. (16 Nm) & 280 lb-in. (32 Nm)	(0) 2-10 Vdc, (0) 4-20 mA, Reversible	20 to 30 Vac at 50/60 Hz	(0) 2-10 Vdc for 90 (1 mA at 10 Vdc). Corresponds to span selection.	2	70-115 for 0-140 lb-in. (0-16 Nm). 80 at 50% load.	MN7220A2205	175 lb-in. (20 Nm)	(0) 2-10 Vdc, (0) 4-20 mA	24 Vac (±20%), 24 Vdc	(0) 2-10 Vdc	2 (5, 85)	95
M9116-JGA-2	140 lb-in. (16 Nm)	100-10 kOhms, Reversible	20 to 30 Vac at 50/60 Hz	0-10 Vdc for 90	—	70-115 for 0-140 lb-in. (0-16 Nm). 80 at 50% load.	—	—	—	—	—	—	—
M9116-JGC-2	140 lb-in. (16 Nm)	100-10 kOhms, Reversible	20 to 30 Vac at 50/60 Hz	0-10 Vdc for 90	2	70-115 for 0-140 lb-in. (0-16 Nm). 80 at 50% load.	—	—	—	—	—	—	—
M9124-AGA-2	210 lb-in. (24 Nm) & 420 lb-in. (48 Nm)	On/Off, Floating	20 to 30 Vac at 50/60 Hz	—	—	115-175 for 0-210 lb-in. (0-24 Nm). 130 at 50% load.	MN6134A1003	300 lb-in. (34 Nm)	On/Off, Floating	24 Vac (±15%), 24 Vdc	—	—	95
M9124-AGC-2	210 lb-in. (24 Nm)	On/Off, Floating	20 to 30 Vac at 50/60 Hz	—	2	115-175 for 0-210 lb-in. (0-24 Nm). 130 at 50% load.	MN6134A1003 + SW2	300 lb-in. (34 Nm)	On/Off, Floating	24 Vac (±15%), 24 Vdc	—	2 (Adjustable)	95

Competitive Cross Reference

Direct Coupled Actuator

Johnson Model	Torque (lb-in.)	Control Signal	Power	Feedback	Switches	Timing (sec)	Honeywell Actuator	Torque (lb-in.)	Control Signal ^a	Power	Feedback ^a	Switches	Timing (sec)
M9124-AGD-2	210 lb-in. (24 Nm)	On/Off, Floating	20 to 30 Vac at 50/60 Hz	0-1 35 Ohm	—	115-175 for 0-210 lb-in. (0-24 Nm). 130 at 50% load.	MN6134A1003	300 lb-in. (34 Nm)	On/Off, Floating	24 Vac (±15%), 24 Vdc	—	—	95
M9124-AGE-2	210 lb-in. (24 Nm)	On/Off, Floating	20 to 30 Vac at 50/60 Hz	0-1 kOhm	—	115-175 for 0-210 lb-in. (0-24 Nm). 130 at 50% load.	MN6134A1003	300 lb-in. (34 Nm)	On/Off, Floating	24 Vac (±15%), 24 Vdc	—	—	95
M9124-GGA-2	210 lb-in. (24 Nm) & 420 lb-in. (48 Nm)	(0) 2-10 Vdc, (0) 4-20 mA, Reversible	20 to 30 Vac at 50/60 Hz	(0) 2-10 Vdc for 90 (1 mA at 10 Vdc) Corresponds to span selection.	—	115-175 for 0-210 lb-in. (0-24 Nm). 130 at 50% load.	MN7234A2008	300 lb-in. (34 Nm)	(0) 2-10 Vdc, (0) 4-20 mA	24 Vac (±20%), 24 Vdc	(0) 2-10 Vdc	—	95
M9124-GGC-2	210 lb-in. (24 Nm) & 420 lb-in. (48 Nm)	(0) 2-10 Vdc, (0) 4-20 mA, Reversible	20 to 30 Vac at 50/60 Hz	(0) 2-10 Vdc for 90 (1 mA at 10 Vdc) Corresponds to span selection.	2	115-175 for 0-210 lb-in. (0-24 Nm). 130 at 50% load.	MN7234A2008 + SW2	300 lb-in. (34 Nm)	(0) 2-10 Vdc, (0) 4-20 mA	24 Vac (±20%), 24 Vdc	(0) 2-10 Vdc	2 (Adjustable)	95
M9124-HGA-2	210 lb-in. (24 Nm) & 420 lb-in. (48 Nm)	(0) 2-10 Vdc, (0) 4-20 mA, Reversible	20 to 30 Vac at 50/60 Hz	(0) 2-10 Vdc for 90 (1 mA at 10 Vdc) Corresponds to span selection.	—	115-175 for 0-210 lb-in. (0-24 Nm). 130 at 50% load.	MN7234A2008	300 lb-in. (34 Nm)	(0) 2-10 Vdc, (0) 4-20 mA	24 Vac (±20%), 24 Vdc	(0) 2-10 Vdc	—	95
M9206-BGA-2S	53 lb-in. (6 Nm)	On/Off	20 to 30 Vac at 50/60 Hz	—	—	10-40 for 0-53 lb-in. (0-6 Nm) 25 at 50% load. Spring return < 70.	MS8110A1008	88 lb-in. (10 Nm)	On/Off	24 Vac (±20%), 24 Vdc	—	—	45
M9206-BGB-2S	53 lb-in. (6 Nm)	On/Off	20 to 30 Vac at 50/60 Hz	—	1	10-40 for 0-53 lb-in. (0-6 Nm) 25 at 50% load. Spring return < 70.	MS8110A1206	88 lb-in. (10 Nm)	On/Off	24 Vac (±20%), 24 Vdc	—	2 (7, 85)	45
M9206-BAA-2S	53 lb-in. (6 Nm)	On/Off	102 to 132 Vac at 60 Hz	—	—	10-40 for 0-53 lb-in. (0-6 Nm) 25 at 50% load. Spring return < 70.	MS4110A1002	88 lb-in. (10 Nm)	On/Off	100-250 Vac	—	—	45
M9206-BAB-2S	53 lb-in. (6 Nm)	On/Off	102 to 132 Vac at 60 Hz	—	1	10-40 for 0-53 lb-in. (0-6 Nm) 25 at 50% load. Spring return < 70.	MS4110A1200	88 lb-in. (10 Nm)	On/Off	100-250 Vac	—	2 (7, 85)	45
M9206-AGA-2S	53 lb-in. (6 Nm)	On/Off, Floating	20 to 30 Vac at 50/60 Hz	—	—	90	MS7510A2008	88 lb-in. (10 Nm)	On/Off, Floating, (0) 2-10 Vdc	24 Vac (±20%), 24 Vdc	(0) 2-10 Vdc	—	90
M9206-AGA-2MP	53 lb-in. (6 Nm)	On/Off, Floating	20 to 30 Vac at 50/60 Hz	—	—	90	MS7510A2008	88 lb-in. (10 Nm)	On/Off, Floating, (0) 2-10 Vdc	24 Vac (±20%), 24 Vdc	(0) 2-10 Vdc	—	90
M9206-AGC-2	53 lb-in. (6 Nm)	On/Off, Floating	20 to 30 Vac at 50/60 Hz	—	2	90	MS7510A2206	88 lb-in. (10 Nm)	On/Off, Floating, (0) 2-10 Vdc	24 Vac (±20%), 24 Vdc	(0) 2-10 Vdc	2 (7, 85)	90
M9206-AGC-2MP	53 lb-in. (6 Nm)	On/Off, Floating	20 to 30 Vac at 50/60 Hz	—	2	90	MS7510A2206	88 lb-in. (10 Nm)	On/Off, Floating, (0) 2-10 Vdc	24 Vac (±20%), 24 Vdc	(0) 2-10 Vdc	2 (7, 85)	90

Competitive Cross Reference

Direct Coupled Actuator

Johnson Model	Torque (lb-in.)	Control Signal	Power	Feedback	Switches	Timing (sec)	Honeywell Actuator	Torque (lb-in.)	Control Signal ^a	Power	Feedback ^a	Switches	Timing (sec)
M9124-HGC-2	210 lb-in. (24 Nm) & 420 lb-in. (48 Nm)	(0) 2-10 Vdc, (0) 4-20 mA, Reversible	20 to 30 Vac at 50/60 Hz	(0) 2-10 Vdc for 90 (1 mA at 10 Vdc) Corresponds to span selection.	2	115-175 for 0-210 lb-in. (0-24 Nm). 130 at 50% load.	MN7234A2008 + SW2	300 lb-in. (34 Nm)	(0) 2-10 Vdc, (0) 4-20 mA	24 Vac (±20%), 24 Vdc	(0) 2-10 Vdc	2 (Adjustable)	95
M9124-JGA-2	210 lb-in. (24 Nm)	100-10 kOhms, Reversible	20 to 30 Vac at 50/60 Hz	0-10 Vdc for 90 (1 mA at 10 Vdc)	—	115-175 for 0-210 lb-in. (0-24 Nm). 130 at 50% load.	—	—	—	—	—	—	—
M9124-JGC-2	210 lb-in. (24 Nm)	100-10 kOhms, Reversible	20 to 30 Vac at 50/60 Hz	0-10 Vdc for 90 (1 mA at 10 Vdc)	2	115-175 for 0-210 lb-in. (0-24 Nm). 130 at 50% load.	—	—	—	—	—	—	—
M9132-AGA-2	280 lb-in. (32 Nm)	On/Off, Floating	20 to 30 Vac at 50/60 Hz	—	—	115-205 for 0-280 lb-in. (0-32 Nm). 140 at 50% load.	MN6134A1003	300 lb-in. (34 Nm)	On/Off, Floating	24 Vac (±15%), 24 Vdc	—	—	95
M9132-AGC-2	280 lb-in. (32 Nm)	On/Off, Floating	20 to 30 Vac at 50/60 Hz	—	2	115-205 for 0-280 lb-in. (0-32 Nm). 140 at 50% load.	MN6134A1003 + SW2	300 lb-in. (34 Nm)	On/Off, Floating	24 Vac (±15%), 24 Vdc	—	2 (Adjustable)	95
M9132-AGE-2	280 lb-in. (32 Nm)	On/Off, Floating	20 to 30 Vac at 50/60 Hz	0-1 kOhm	—	115-205 for 0-280 lb-in. (0-32 Nm). 140 at 50% load.	MN6134A1003	300 lb-in. (34 Nm)	On/Off, Floating	24 Vac (±15%), 24 Vdc	—	—	95
M9132-GGA-2	280 lb-in. (32 Nm) & 560 lb-in. (64 Nm)	(0) 2-10 Vdc, (0) 4 to 20 mA, Reversible	20 to 30 Vac at 50/60 Hz	(0) 2-10 Vdc for 90 (1 mA at 10 Vdc) Corresponds to span and stroke limits	—	115-205 for 0-280 lb-in. (0-32 Nm). 140 at 50% load.	MN7234A2008	300 lb-in. (34 Nm)	(0) 2-10 Vdc, (0) 4-20 mA	24 Vac (±20%), 24 Vdc	(0) 2-10 Vdc	—	95
M9132-GGC-2	280 lb-in. (32 Nm) & 560 lb-in. (64 Nm)	(0) 2-10 Vdc, (0) 4 to 20 mA, Reversible	20 to 30 Vac at 50/60 Hz	(0) 2-10 Vdc for 90 (1 mA at 10 Vdc) Corresponds to span and stroke limits	2	115-205 for 0-280 lb-in. (0-32 Nm). 140 at 50% load.	MN7234A2008 + SW2	300 lb-in. (34 Nm)	(0) 2-10 Vdc, (0) 4-20 mA	24 Vac (±20%), 24 Vdc	(0) 2-10 Vdc	2 (Adjustable)	95
							MS4105A1002	44 lb-in. (5 Nm)	On/Off	100-250 Vac	—	—	45
M9206-GGA-2	53 lb-in. (6 Nm)	(0) 2-10 Vdc, 6-9 Vdc, (0) 4-20 mA, Reversible	20 to 30 Vac at 50/60 Hz	(0) 2-10 Vdc for 90 (1 mA at 10 Vdc) Corresponds to span and stroke limits	—	90	MS7510A2008	88 lb-in. (10 Nm)	On/Off, Floating, (0) 2-10 Vdc	24 Vac (±20%), 24 Vdc	(0) 2-10 Vdc	—	90
M9206-GGA-2MP	53 lb-in. (6 Nm)	(0) 2-10 Vdc, 6-9 Vdc, (0) 4-20 mA, Reversible	20 to 30 Vac at 50/60 Hz	(0) 2-10 Vdc for 90 (1 mA at 10 Vdc) Corresponds to span and stroke limits	—	90	MS7510A2008	88 lb-in. (10 Nm)	On/Off, Floating, (0) 2-10 Vdc	24 Vac (±20%), 24 Vdc	(0) 2-10 Vdc	—	90
M9206-GGC-2	53 lb-in. (6 Nm)	(0) 2-10 Vdc, 6-9 Vdc, (0) 4-20 mA, Reversible	20 to 30 Vac at 50/60 Hz	(0) 2-10 Vdc for 90 (1 mA at 10 Vdc) Corresponds to span and stroke limits	2	90	MS7510A2206	88 lb-in. (10 Nm)	On/Off, Floating, (0) 2-10 Vdc	24 Vac (±20%), 24 Vdc	(0) 2-10 Vdc	2 (7, 85)	90
M9206-GGC-2MP	53 lb-in. (6 Nm)	(0) 2-10 Vdc, 6-9 Vdc, (0) 4-20 mA, Reversible	20 to 30 Vac at 50/60 Hz	(0) 2-10 Vdc for 90 (1 mA at 10 Vdc) Corresponds to span and stroke limits	2	90	MS7510A2206	88 lb-in. (10 Nm)	On/Off, Floating, (0) 2-10 Vdc	24 Vac (±20%), 24 Vdc	(0) 2-10 Vdc	2 (7, 85)	90
							MS7510H2209	88 lb-in. (10 Nm)	On/Off, Floating, (0) 2-10 Vdc	24 Vac (±20%), 24 Vdc	(0) 2-10 Vdc	2 (7, 85)	90

Competitive Cross Reference

Direct Coupled Actuator

Johnson Model	Torque (lb-in.)	Control Signal	Power	Feedback	Switches	Timing (sec)	Honeywell Actuator	Torque (lb-in.)	Control Signal ^a	Power	Feedback ^a	Switches	Timing (sec)
M9216-BAA-2	140 lb-in. (16 Nm) & 280 lb-in. (32 Nm)	On/Off	120 Vac	—	—	—	MS4120A1001	175 lb-in. (20 Nm)	On/Off	100-250 Vac	—	—	45
M9216-BAC-2	140 lb-in. (16 Nm) & 280 lb-in. (32 Nm)	On/Off	120 Vac	—	2	—	MS4120A1209	175 lb-in. (20 Nm)	On/Off	100-250 Vac	—	2 (7, 85)	45
M9216-BGA-2	140 lb-in. (16 Nm) & 280 lb-in. (32 Nm)	On/Off	20 to 30 Vac at 50/60 Hz or 24 Vdc, 420 mA	—	—	70-130 for 0-140 lb-in. (0-16 Nm), 90 at 50% load. Spring return < 15.	MS8120A1007	175 lb-in. (20 Nm)	On/Off	24 Vac (±20%), 24 Vdc	—	—	45
M9216-BGC-2	140 lb-in. (16 Nm) & 280 lb-in. (32 Nm)	On/Off	20 to 30 Vac at 50/60 Hz or 24 Vdc, 420 mA	—	2	70-130 for 0-140 lb-in. (0-16 Nm), 90 at 50% load. Spring return < 15.	MS8120A1205	175 lb-in. (20 Nm)	On/Off	24 Vac (±20%), 24 Vdc	—	2 (7, 85)	45
M9216-AGA-2	140 lb-in. (16 Nm)	On/Off, Floating	20 to 30 Vac at 50/60 Hz or 24 Vdc, 420 mA	—	—	70-130 for 0-140 lb-in. (0-16 Nm), 90 at 50% load. Spring return < 15.	MS7520A2007	175 lb-in. (20 Nm)	On/Off, Floating, (0) 2-10 Vdc	24 Vac (±20%), 24 Vdc	(0) 2-10 Vdc	—	90
M9216-AGC-2	140 lb-in. (16 Nm)	On/Off, Floating	20 to 30 Vac at 50/60 Hz or 24 Vdc, 420 mA	—	2	70-130 for 0-140 lb-in. (0-16 Nm), 90 at 50% load. Spring return < 15.	MS7520A2205	175 lb-in. (20 Nm)	On/Off, Floating, (0) 2-10 Vdc	24 Vac (±20%), 24 Vdc	(0) 2-10 Vdc	2 (7, 85)	90
M9216-AGD-2	140 lb-in. (16 Nm)	On/Off, Floating	20 to 30 Vac at 50/60 Hz or 24 Vdc, 420 mA	0-135 Ohms	—	70-130 for 0-140 lb-in. (0-16 Nm), 90 at 50% load. Spring return < 15.	MS7520A2007	175 lb-in. (20 Nm)	On/Off, Floating, (0) 2-10 Vdc	24 Vac (±20%), 24 Vdc	(0) 2-10 Vdc	—	90
M9216-AGE-2	140 lb-in. (16 Nm)	On/Off, Floating	20 to 30 Vac at 50/60 Hz or 24 Vdc, 420 mA	0-1 kOhms	—	70-130 for 0-140 lb-in. (0-16 Nm), 90 at 50% load. Spring return < 15.	MS7520A2007	175 lb-in. (20 Nm)	On/Off, Floating, (0) 2-10 Vdc	24 Vac (±20%), 24 Vdc	(0) 2-10 Vdc	—	90
M9216-GGA-2	140 lb-in. (16 Nm) & 280 lb-in. (32 Nm)	0-10 Vdc, 0-20 mA, Reversible	20 to 30 Vac at 50/60 Hz or 24 Vdc, 420 mA	(0) 2-10 Vdc for 90 (1 mA at 10 Vdc) Corresponds to span and stroke limits	—	70-130 for 0-140 lb-in. (0-16 Nm), 90 at 50% load. Spring return < 15.	MS7520A2007	175 lb-in. (20 Nm)	On/Off, Floating, (0) 2-10 Vdc	24 Vac (±20%), 24 Vdc	(0) 2-10 Vdc	—	90
M9216-GGC-2	140 lb-in. (16 Nm) & 280 lb-in. (32 Nm)	0-10 Vdc, 0-20 mA, Reversible	20 to 30 Vac at 50/60 Hz or 24 Vdc, 420 mA	(0) 2-10 Vdc for 90 (1 mA at 10 Vdc) Corresponds to span and stroke limits	2	70-130 for 0-140 lb-in. (0-16 Nm), 90 at 50% load. Spring return < 15.	MS7520A2205	175 lb-in. (20 Nm)	On/Off, Floating, (0) 2-10 Vdc	24 Vac (±20%), 24 Vdc	(0) 2-10 Vdc	2 (7, 85)	90

Competitive Cross Reference

Direct Coupled Actuator

Johnson Model	Torque (lb-in.)	Control Signal	Power	Feedback	Switches	Timing (sec)	Honeywell Actuator	Torque (lb-in.)	Control Signal ^a	Power	Feedback ^a	Switches	Timing (sec)
M9216-HGA-2	140 lb-in. (16 Nm) & 280 lb-in. (32 Nm)	0-10 Vdc, 0-20 mA, Reversible	20 to 30 Vac at 50/60 Hz or 24 Vdc, 420 mA	(0) 2-10 Vdc for 90 (1 mA at 10 Vdc) Corresponds to span and stroke limits	—	70-130 for 0-140 lb-in. (0-16 Nm), 90 at 50% load. Spring return < 15.	MS7520H2208	175 lb-in. (20 Nm)	On/Off, Floating, (0) 2-10 Vdc	24 Vac (±20%), 24 Vdc	(0) 2-10 Vdc	2 (7, 85)	90
M9216-HGC-2	140 lb-in. (16 Nm) & 280 lb-in. (32 Nm)	100-10 kOhm Reversible	20 to 30 Vac at 50/60 Hz or 24 Vdc, 420 mA	(0) 2-10 Vdc for 90 (1 mA at 10 Vdc) Corresponds to span and stroke limits	2	70-130 for 0-140 lb-in. (0-16 Nm), 90 at 50% load. Spring return < 15.	MS7520H2208	175 lb-in. (20 Nm)	On/Off, Floating, (0) 2-10 Vdc	24 Vac (±20%), 24 Vdc	(0) 2-10 Vdc	2 (7, 85)	90
M9216-JGA-2	140 lb-in. (16 Nm)	100-10 kOhm Reversible	20 to 30 Vac at 50/60 Hz or 24 Vdc, 420 mA	0-10 Vdc for 90 (1 mA at 10 Vdc)	—	70-130 for 0-140 lb-in. (0-16 Nm), 90 at 50% load. Spring return < 15.	—	—	—	—	—	—	—
M9216-JGC-2	140 lb-in. (16 Nm)	100-10 kOhm Reversible	20 to 30 Vac at 50/60 Hz or 24 Vdc, 420 mA	0-10 Vdc for 90 (1 mA at 10 Vdc)	2	70-130 for 0-140 lb-in. (0-16 Nm), 90 at 50% load. Spring return < 15.	—	—	—	—	—	—	—

^a All models described as (0) 2-10 Vdc can be used with a 4-20 mA control input. Shunt a 500 ohm, 1/2 W resistor across the input at the actuator.

Invensys Model	Torque (lb-in.)	Control Signal	Power	Feedback	Switches	Timing (sec)	Honeywell Actuator	Torque (lb-in.)	Control Signal ^a	Power	Feedback ^a	Switches	Timing (sec)
MA40-7043	35 lb-in. (4 Nm)	On/Off	24 Vac ±20% 22-30 Vdc	—	-	< 50	MS8105A1030	44 lb-in. (5 Nm)	On/Off	24 Vac (±20%), 24 Vdc	—	—	45
MA40-7043-501	35 lb-in. (4 Nm)	On/Off	24 Vac ±20% 22-30 Vdc	—	1	< 50	MS8105A1130	44 lb-in. (5 Nm)	On/Off	24 Vac (±20%), 24 Vdc	—	1 (Adjustable)	45
MF40-7043	35 lb-in. (4 Nm)	Floating	24 Vac ±20% 22-30 Vdc	—	-	< 130	MS7505A2030	44 lb-in. (5 Nm)	On/Off, Floating, (0) 2-10 Vdc	24 Vac (±20%), 24 Vdc	(0) 2-10 Vdc	—	90
MF40-7043-501	35 lb-in. (4 Nm)	Floating	24 Vac ±20% 22-30 Vdc	—	1	< 130	MS7505A2130	44 lb-in. (5 Nm)	On/Off, Floating, (0) 2-10 Vdc	24 Vac (±20%), 24 Vdc	(0) 2-10 Vdc	1 (Adjustable)	90
MS40-7043	35 lb-in. (4 Nm)	2-10 Vdc 4-20 mA	24 Vac ±20% 22-30 Vdc	2-10 Vdc	-	< 130	MS7505A2030	44 lb-in. (5 Nm)	On/Off, Floating, (0) 2-10 Vdc	24 Vac (±20%), 24 Vdc	(0) 2-10 Vdc	—	90
MS40-7043-501	35 lb-in. (4 Nm)	2-10 Vdc 4-20 mA	24 Vac ±20% 22-30 Vdc	2-10 Vdc	1	< 130	MS7505A2130	44 lb-in. (5 Nm)	On/Off, Floating, (0) 2-10 Vdc	24 Vac (±20%), 24 Vdc	(0) 2-10 Vdc	1 (Adjustable)	90
MA41-7073	60 lb-in. (7 Nm)	On/Off	24 Vac ±20% 22-30 Vdc	—	-	< 80	MS8110A1008	88 lb-in. (10 Nm)	On/Off	24 Vac (±20%), 24 Vdc	—	—	45
MA41-7073-502	60 lb-in. (7 Nm)	On/Off	24 Vac ±20% 22-30 Vdc	—	2	< 80	MS8110A1206	88 lb-in. (10 Nm)	On/Off	24 Vac (±20%), 24 Vdc	—	2 (7, 85)	45
MF41-7073	60 lb-in. (7 Nm)	Floating	24 Vac ±20% 22-30 Vdc	—	-	< 195	MS7510A2008	88 lb-in. (10 Nm)	On/Off, Floating, (0) 2-10 Vdc	24 Vac (±20%), 24 Vdc	(0) 2-10 Vdc	—	90
MF41-7073-502	60 lb-in. (7 Nm)	Floating	24 Vac ±20% 22-30 Vdc	—	2	< 195	MS7510A2206	88 lb-in. (10 Nm)	On/Off, Floating, (0) 2-10 Vdc	24 Vac (±20%), 24 Vdc	(0) 2-10 Vdc	2 (7, 85)	90
MS41-7073	60 lb-in. (7 Nm)	2-10 Vdc 4-20 mA	24 Vac ±20% 22-30 Vdc	2-10 Vdc	-	< 195	MS7510A2008	88 lb-in. (10 Nm)	On/Off, Floating, (0) 2-10 Vdc	24 Vac (±20%), 24 Vdc	(0) 2-10 Vdc	—	90
MS41-7073-502	60 lb-in. (7 Nm)	2-10 Vdc 4-20 mA	24 Vac ±20% 22-30 Vdc	2-10 Vdc	2	< 195	MS7510A2206	88 lb-in. (10 Nm)	On/Off, Floating, (0) 2-10 Vdc	24 Vac (±20%), 24 Vdc	(0) 2-10 Vdc	2 (7, 85)	90

Competitive Cross Reference

Direct Coupled Actuator

Invensys Model	Torque (lb-in.)	Control Signal	Power	Feedback	Switches	Timing (sec)	Honeywell Actuator	Torque (lb-in.)	Control Signal ^a	Power	Feedback ^a	Switches	Timing (sec)
MA41-7153	133 lb-in. (15 Nm)	On/Off	24 Vac ±20% 22-30 Vdc	—	-	< 190	MS8120A1007	175 lb-in. (20 Nm)	On/Off	24 Vac (±20%), 24 Vdc	—	—	45
MA41-7153-502	133 lb-in. (15 Nm)	On/Off	24 Vac ±20% 22-30 Vdc	—	2	< 190	MS8120A1205	175 lb-in. (20 Nm)	On/Off	24 Vac (±20%), 24 Vdc	—	2 (7, 85)	45
MF41-7153	133 lb-in. (15 Nm)	Floating	24 Vac ±20% 22-30 Vdc	—	-	< 190	MS7520A2007	175 lb-in. (20 Nm)	On/Off, Floating, (0) 2-10 Vdc	24 Vac (±20%), 24 Vdc	(0) 2-10 Vdc	—	90
MF41-7153-502	133 lb-in. (15 Nm)	Floating	24 Vac ±20% 22-30 Vdc	—	2	< 190	MS7520A2205	175 lb-in. (20 Nm)	On/Off, Floating, (0) 2-10 Vdc	24 Vac (±20%), 24 Vdc	(0) 2-10 Vdc	2 (7, 85)	90
MS41-7153	133 lb-in. (15 Nm)	2-10 Vdc	24 Vac ±20% 22-30 Vdc	2-10 Vdc	-	< 190	MS7520A2007	175 lb-in. (20 Nm)	On/Off, Floating, (0) 2-10 Vdc	24 Vac (±20%), 24 Vdc	(0) 2-10 Vdc	—	90
MS41-7153-502	133 lb-in. (15 Nm)	2-10 Vdc	24 Vac ±20% 22-30 Vdc	2-10 Vdc	2	< 190	MS7520A2205	175 lb-in. (20 Nm)	On/Off, Floating, (0) 2-10 Vdc	24 Vac (±20%), 24 Vdc	(0) 2-10 Vdc	2 (7, 85)	90
MA40-7170	150 lb-in. (17 Nm)	On/Off	120 Vac ±10%	—	-	< 145	MS4120A1001	175 lb-in. (20 Nm)	On/Off	100-250 Vac	—	—	45
MA40-7173	150 lb-in. (17 Nm)	On/Off	24 Vac ±20%	—	-	< 145	MS8120A1007	175 lb-in. (20 Nm)	On/Off	24 Vac (±20%), 24 Vdc	—	—	45
MF40-7173	150 lb-in. (17 Nm)	Floating	24 Vac ±20%	—	-	< 145	MS7520A2007	175 lb-in. (20 Nm)	On/Off, Floating, (0) 2-10 Vdc	24 Vac (±20%), 24 Vdc	(0) 2-10 Vdc	—	90
MS40-7170	150 lb-in. (17 Nm)	2-10 Vdc 4-20 mA	120 Vac ±10%	—	-	< 145	MS7520A2007	175 lb-in. (20 Nm)	On/Off, Floating, (0) 2-10 Vdc	24 Vac (±20%), 24 Vdc	(0) 2-10 Vdc	—	90
MS40-7173	150 lb-in. (17 Nm)	2-10 Vdc 4-20 mA	24 Vac ±20%	—	-	< 145	MS7520A2007	175 lb-in. (20 Nm)	On/Off, Floating, (0) 2-10 Vdc	24 Vac (±20%), 24 Vdc	(0) 2-10 Vdc	—	90
MA4D-7033-100	30 lb-in. (3.4 Nm)	On/Off	24 Vac ±20% 20-30 Vdc	—	-	< 56	MS8105A1008	44 lb-in. (5 Nm)	On/Off	24 Vac (±20%), 24 Vdc	—	—	45
MA4D-8033-100	30 lb-in. (3.4 Nm)	On/Off	24 Vac ±20% 20-30 Vdc	—	-	< 56	MS8105A1008	44 lb-in. (5 Nm)	On/Off	24 Vac (±20%), 24 Vdc	—	—	45
MF4D-7033-100	30 lb-in. (3.4 Nm)	Floating	24 Vac ±20% 20-30 Vdc	2-10 Vdc	-	< 85	MS7505A2008	44 lb-in. (5 Nm)	On/Off, Floating, (0) 2-10 Vdc	24 Vac (±20%), 24 Vdc	(0) 2-10 Vdc	—	90
MF4D-8033-100	30 lb-in. (3.4 Nm)	Floating	24 Vac ±20% 20-30 Vdc	2-10 Vdc	-	< 85	MS7505A2008	44 lb-in. (5 Nm)	On/Off, Floating, (0) 2-10 Vdc	24 Vac (±20%), 24 Vdc	(0) 2-10 Vdc	—	90
MS4D-7033-100	30 lb-in. (3.4 Nm)	(0) 2-10 Vdc, 4-20 mA	24 Vac ±20% 20-30 Vdc	2-10 Vdc	-	< 85	MS7505A2008	44 lb-in. (5 Nm)	On/Off, Floating, (0) 2-10 Vdc	24 Vac (±20%), 24 Vdc	(0) 2-10 Vdc	—	90
MS4D-7033-150	30 lb-in. (3.4 Nm)	(0) 2-10 Vdc, 4-20 mA	24 Vac ±20% 20-30 Vdc	2-10 Vdc	-	< 85	MS7505A2008	44 lb-in. (5 Nm)	On/Off, Floating, (0) 2-10 Vdc	24 Vac (±20%), 24 Vdc	(0) 2-10 Vdc	—	90
MS4D-7033-160	30 lb-in. (3.4 Nm)	(0) 2-10 Vdc, 4-20 mA	24 Vac ±20% 22-30 Vdc	2-10 Vdc	—	< 85	MS7505A2008	44 lb-in. (5 Nm)	On/Off, Floating, (0) 2-10 Vdc	24 Vac (±20%), 24 Vdc	(0) 2-10 Vdc	—	90
MS4D-8033-100	30 lb-in. (3.4 Nm)	(0) 2-10 Vdc, 4-20 mA	24 Vac ±20% 22-30 Vdc	2-10 Vdc	—	< 85	MS7505A2008	44 lb-in. (5 Nm)	On/Off, Floating, (0) 2-10 Vdc	24 Vac (±20%), 24 Vdc	(0) 2-10 Vdc	—	90
MS4D-8033-150	30 lb-in. (3.4 Nm)	(0) 2-10 Vdc, 4-20 mA	24 Vac ±20% 22-30 Vdc	2-10 Vdc	—	< 85	MS7505A2008	44 lb-in. (5 Nm)	On/Off, Floating, (0) 2-10 Vdc	24 Vac (±20%), 24 Vdc	(0) 2-10 Vdc	—	90
MS4D-8033-160	30 lb-in. (3.4 Nm)	(0) 2-10 Vdc, 4-20 mA	24 Vac ±20% 22-30 Vdc	2-10 Vdc	—	< 85	MS7505A2008	44 lb-in. (5 Nm)	On/Off, Floating, (0) 2-10 Vdc	24 Vac (±20%), 24 Vdc	(0) 2-10 Vdc	—	90
MS50-E2301	150 lb-in. (17 Nm)	1-5 Vdc 4-20 mA	24 Vac ±10%	—	—	145	MS7520A2007	175 lb-in. (20 Nm)	On/Off, Floating, (0) 2-10 Vdc	24 Vac (±20%), 24 Vdc	(0) 2-10 Vdc	—	90
MS50-E2001	150 lb-in. (17 Nm)	1-5 Vdc 4-20 mA	120 Vac ±10%	—	—	145	MS7520A2007	175 lb-in. (20 Nm)	On/Off, Floating, (0) 2-10 Vdc	24 Vac (±20%), 24 Vdc	(0) 2-10 Vdc	—	90
MS50-E2101	150 lb-in. (17 Nm)	1-5 Vdc 4-20 mA	240 Vac ±10%	—	—	145	MS7520A2007	175 lb-in. (20 Nm)	On/Off	24 Vac (±20%), 24 Vdc	(0) 2-10 Vdc	—	90

CROSS REFERENCE

Competitive Cross Reference

Direct Coupled Actuator

Invensys Model	Torque (lb-in.)	Control Signal	Power	Feedback	Switches	Timing (sec)	Honeywell Actuator	Torque (lb-in.)	Control Signal ^a	Power	Feedback ^a	Switches	Timing (sec)
MF41-6043	30 lb-in. (3.4 Nm)	Floating	24 Vac 0.05	—	—	< 90	MN6105A1011	44 lb-in. (5 Nm)	On/Off, Floating	24 Vac/Vdc (+20 / -15%)	—	—	95
MF41-6043-510	30 lb-in. (3.4 Nm)	Floating	24 Vac 0.05	0-1k0hm	—	< 90	—	—	—	—	—	—	—
MF41-6043-502	30 lb-in. (3.4 Nm)	Floating	24 Vac 0.05	—	2	< 90	MN6105A1201	44 lb-in. (5 Nm)	On/Off, Floating	24 Vac/Vdc (+20 / -15%)	—	2 (7, 85)	95
MS41-6043	30 lb-in. (3.4 Nm)	0-10 Vdc	24 Vac 0.05	0-10 Vdc	-	< 90	MN7505A2001	44 lb-in. (5 Nm)	On/Off, Floating, (0) 2-10 Vdc	24 Vac/Vdc (+20 / -15%)	(0) 2-10 Vdc	—	95
MS41-6043-520	30 lb-in. (3.4 Nm)	0-10 Vdc (adjustable)	24 Vac 0.05	0-10 Vdc	-	< 90	MN7505A2001	44 lb-in. (5 Nm)	On/Off, Floating, (0) 2-10 Vdc	24 Vac/Vdc (+20 / -15%)	(0) 2-10 Vdc	—	95
MS41-6043-522	30 lb-in. (3.4 Nm)	0-10 Vdc (adjustable)	24 Vac 0.05	0-10 Vdc	2	< 90	MN7505A2209	44 lb-in. (5 Nm)	On/Off, Floating, (0) 2-10 Vdc	24 Vac/Vdc (+20 / -15%)	(0) 2-10 Vdc	2 (5, 85)	95
MS41-6043-502	30 lb-in. (3.4 Nm)	0-10 Vdc	24 Vac 0.05	0-10 Vdc	2	< 90	MN7505A2209	44 lb-in. (5 Nm)	On/Off, Floating, (0) 2-10 Vdc	24 Vac/Vdc (+20 / -15%)	(0) 2-10 Vdc	2 (5, 85)	95
MF41-6083	70 lb-in. (8 Nm)	Floating	24 Vac 0.05	—	-	< 125	MN6110A1003	88 lb-in. (10 Nm)	On/Off, Floating	24 Vac/Vdc (+20 / -15%)	—	—	95
MF41-6083-510	70 lb-in. (8 Nm)	Floating	24 Vac 0.05	0-1k0hm	-	< 125	—	—	—	—	—	—	—
MF41-6083-502	70 lb-in. (8 Nm)	Floating	24 Vac 0.05	—	2	< 125	MN6110A1201	88 lb-in. (10 Nm)	On/Off, Floating	24 Vac/Vdc (+20 / -15%)	—	2 (5, 85)	95
MS41-6083	70 lb-in. (8 Nm)	0-10 Vdc	24 Vac 0.05	0-10 Vdc	-	< 125	MN7510A2001	88 lb-in. (10 Nm)	On/Off, Floating, (0) 2-10 Vdc	24 Vac/Vdc (+20 / -15%)	(0) 2-10 Vdc	—	95
MS41-6083-520	70 lb-in. (8 Nm)	0-10 Vdc (adjustable)	24 Vac 0.05	0-10 Vdc	-	< 125	MN7510A2001	88 lb-in. (10 Nm)	On/Off, Floating, (0) 2-10 Vdc	24 Vac/Vdc (+20 / -15%)	(0) 2-10 Vdc	—	95
MS41-6083-522	70 lb-in. (8 Nm)	0-10 Vdc (adjustable)	24 Vac 0.05	0-10 Vdc	2	< 125	MN7510A2209	88 lb-in. (10 Nm)	On/Off, Floating, (0) 2-10 Vdc	24 Vac/Vdc (+20 / -15%)	(0) 2-10 Vdc	2 (5, 85)	95
MS41-6083-502	70 lb-in. (8 Nm)	0-10 Vdc	24 Vac 0.05	0-10 Vdc	2	< 125	MN7510A2209	88 lb-in. (10 Nm)	On/Off, Floating, (0) 2-10 Vdc	24 Vac/Vdc (+20 / -15%)	(0) 2-10 Vdc	2 (5, 85)	95
MF41-6153	133 lb-in. (15 Nm)	Floating	24 Vac 0.05	—	-	< 125	MN6120A1002	175 lb-in. (20 Nm)	On/Off, Floating	24 Vac/Vdc (+20 / -15%)	—	—	95
MS41-6153	133 lb-in. (15 Nm)	0-10 Vdc	24 Vac 0.05	0-10 Vdc	-	< 125	MN7220A2007	175 lb-in. (20 Nm)	(0) 2-10 Vdc, (0) 4-20 mA	24 Vac (±20%), 24 Vdc	(0) 2-10 Vdc	—	95
MS41-6153-502	133 lb-in. (15 Nm)	0-10 Vdc	24 Vac 0.05	0-10 Vdc	2	< 125	MN7220A2205	175 lb-in. (20 Nm)	(0) 2-10 Vdc, (0) 4-20 mA	24 Vac (±20%), 24 Vdc	(0) 2-10 Vdc	2 (5, 85)	95
MF41-6343	300 lb-in. (34 Nm)	Floating	24 Vac ±20%	—	-	< 145	MN6134A1003	300 lb-in. (34 Nm)	On/Off, Floating	24 Vac (±15%), 24 Vdc	—	—	95
MS41-6340	300 lb-in. (34 Nm)	2-10 Vdc 4-20 mA	120 Vac ±10%	—	-	< 145	MN7234A2008	300 lb-in. (34 Nm)	(0) 2-10 Vdc, (0) 4-20 mA	24 Vac (±20%), 24 Vdc	(0) 2-10 Vdc	—	95
MS41-6343	300 lb-in. (34 Nm)	2-10 Vdc 4-20 mA	24 Vac ±20%	—	-	< 145	MN7234A2008	300 lb-in. (34 Nm)	(0) 2-10 Vdc, (0) 4-20 mA	24 Vac (±20%), 24 Vdc	(0) 2-10 Vdc	—	95
MS4D-6043-100	35 lb-in. (4 Nm)	2-10 Vdc	24 Vac ±20% 20-30 Vdc	2-10 Vdc	-	< 85	MN7505A2001	44 lb-in. (5 Nm)	On/Off, Floating, (0) 2-10 Vdc	24 Vac/Vdc (+20 / -15%)	(0) 2-10 Vdc	—	95
MS4D-6043-150	35 lb-in. (4 Nm)	0-10 Vdc	24 Vac ±20% 20-30 Vdc	2-10 Vdc	-	< 85	MN7505A2001	44 lb-in. (5 Nm)	On/Off, Floating, (0) 2-10 Vdc	24 Vac/Vdc (+20 / -15%)	(0) 2-10 Vdc	—	95
MS4D-6043-160	35 lb-in. (4 Nm)	4-20 mA	24 Vac ±20% 20-30 Vdc	2-10 Vdc	-	< 85	MN7505A2001	44 lb-in. (5 Nm)	On/Off, Floating, (0) 2-10 Vdc	24 Vac/Vdc (+20 / -15%)	(0) 2-10 Vdc	—	95
MS4D-6083-100	70 lb-in. (8 Nm)	2-10 Vdc	24 Vac ±20% 20-30 Vdc	2-10 Vdc	-	< 85	MN7510A2001	88 lb-in. (10 Nm)	On/Off, Floating, (0) 2-10 Vdc	24 Vac/Vdc (+20 / -15%)	(0) 2-10 Vdc	—	95
MS4D-6083-150	70 lb-in. (8 Nm)	0-10 Vdc	24 Vac ±20% 20-30 Vdc	2-10 Vdc	-	< 85	MN7510A2001	88 lb-in. (10 Nm)	On/Off, Floating, (0) 2-10 Vdc	24 Vac/Vdc (+20 / -15%)	(0) 2-10 Vdc	—	95

Competitive Cross Reference

Direct Coupled Actuator

Invensys Model	Torque (lb-in.)	Control Signal	Power	Feedback	Switches	Timing (sec)	Honeywell Actuator	Torque (lb-in.)	Control Signal ^a	Power	Feedback ^a	Switches	Timing (sec)
MS4D-6083-160	70 lb-in. (8 Nm)	4-20 mA	24 Vac ±20% 20-30 Vdc	2-10 Vdc	-	< 85	MN7510A2001	88 lb-in. (10 Nm)	On/Off, Floating, (0) 2-10 Vdc	24 Vac/Vdc (+20 / -15%)	(0) 2-10 Vdc	—	95
MF4E-60430-100	35 lb-in. (4 Nm)	Floating	24 Vac + 20%- 15%	—	-	90	MN6105A1011	44 lb-in. (5 Nm)	On/Off, Floating	24 Vac/Vdc (+20 / -15%)	—	—	95
MF4E-60830-100	70 lb-in. (8 Nm)	Floating	24 Vac + 20%- 15%	—	-	90	MN6110A1003	88 lb-in. (10 Nm)	On/Off, Floating	24 Vac/Vdc (+20 / -15%)	—	—	95
MS50-H2301	300 lb-in. (34 Nm)	1-5 Vdc 4-20 mA	24 Vac ±10%	—	-	145	MN7234A2008	300 lb-in. (34 Nm)	(0) 2-10 Vdc, (0) 4-20 mA	24 Vac (±20%), 24 Vdc	(0) 2-10 Vdc	—	95
MS50-H2001	300 lb-in. (34 Nm)	1-5 Vdc 4-20 mA	120 Vac ±10%	—	-	145	MN7234A2008	300 lb-in. (34 Nm)	(0) 2-10 Vdc, (0) 4-20 mA	24 Vac (±20%), 24 Vdc	(0) 2-10 Vdc	—	95
MS50-H2101	300 lb-in. (34 Nm)	1-5 Vdc 4-20 mA	240 Vac ±10%	—	-	145	MN7234A2008	300 lb-in. (34 Nm)	(0) 2-10 Vdc, (0) 4-20 mA	24 Vac (±20%), 24 Vdc	(0) 2-10 Vdc	—	95
—	—	—	—	—	—	—	MN6120A1200	175 lb-in. (20 Nm)	On/Off, Floating	24 Vac (±15%), 24 Vdc	—	2 (5, 85)	95

^a All models described as (0) 2-10 Vdc can be used with a 4-20 mA control input. Shunt a 500 ohm, 1/2 W resistor across the input at the actuator.

Siemens Model	Torque (lb-in.)	Control Signal	Power	Feedback	Switches	Timing (sec)	Honeywell Actuator	Torque (lb-in.)	Control Signal ^a	Power	Feedback ^a	Switches	Timing (sec)
—	—	—	—	—	—	—	MN7505A2209	44 lb-in. (5 Nm)	On/Off, Floating, (0) 2-10 Vdc	24 Vac/Vdc - 15%/+20%	(0) 2-10 Vdc	2 (5, 85)	95
GDE131.1U	44 lb-in. (5 Nm)	Floating	24 Vac	—	—	90	MN6105A1011	44 lb-in. (5 Nm)	On/Off, Floating	24 Vac/Vdc (+20 / -15%)	—	—	95
GDE131.1P	44 lb-in. (5 Nm)	Floating	24 Vac	—	—	90							
GDE131.1T	44 lb-in. (5 Nm)	Floating	24 Vac	—	—	90							
GDE161.1P	44 lb-in. (5 Nm)	0-10 Vdc	24 Vac	0-1k0hm	—	90	MN7505A2001	44 lb-in. (5 Nm)	On/Off, Floating, (0) 2-10 Vdc	24 Vac/Vdc (+20 / -15%)	(0) 2-10 Vdc	—	95
GDE161.1T	44 lb-in. (5 Nm)	0-10 Vdc	24 Vac	0-1k0hm	—	90							
GDE132.1P	44 lb-in. (5 Nm)	Floating	24 Vac	0-1k0hm	—	90	ML6174A2002 + 200976C	70 lb-in. (8 Nm)	On/Off, Floating	24 Vac	0-2 k0hm	—	95
GDE136.1P	44 lb-in. (5 Nm)	Floating	24 Vac	—	2	90	MN6105A1201	44 lb-in. (5 Nm)	On/Off, Floating	24 Vac/Vdc (+20 / -15%)	—	2 (5, 85)	95
GDE163.1P	44 lb-in. (5 Nm)	0-10 Vdc	24 Vac	0-1k0hm	—	90	—	—	—	—	—	—	—
GDE164.1P	44 lb-in. (5 Nm)	0-10 Vdc	24 Vac	0-1k0hm	2	90	—	—	—	—	—	—	—
GDE166.1P	44 lb-in. (5 Nm)	0-10 Vdc	24 Vac	0-1k0hm	2	90	—	—	—	—	—	—	—
GLB131.1P	88 lb-in. (10 Nm)	Floating	24 Vac	—	—	125	MN6110A1003	88 lb-in. (10 Nm)	On/Off, Floating	24 Vac/Vdc (+20 / -15%)	—	—	95
GLB161.1P	88 lb-in. (10 Nm)	0-10 Vdc	24 Vac	—	—	125	MN7510A2001	88 lb-in. (10 Nm)	On/Off, Floating, (0) 2-10 Vdc	24 Vac/Vdc (+20 / -15%)	(0) 2-10 Vdc	—	95
GLB132.1P	88 lb-in. (10 Nm)	Floating	24 Vac	0-1k0hm	—	125	ML6174A2002 + 200976C	70 lb-in. (8 Nm)	On/Off, Floating	24 Vac	0-2 k0hm	—	95
GLB136.1P	88 lb-in. (10 Nm)	Floating	24 Vac	—	2	125	MN6110A1201	88 lb-in. (10 Nm)	On/Off, Floating	24 Vac/Vdc (+20 / -15%)	—	2 (5, 85)	95
GLB163.1P	88 lb-in. (10 Nm)	0-10 Vdc	24 Vac	—	—	125	MN7510A2001	88 lb-in. (10 Nm)	On/Off, Floating, (0) 2-10 Vdc	24 Vac/Vdc (+20 / -15%)	(0) 2-10 Vdc	—	95
GLB164.1P	88 lb-in. (10 Nm)	0-10 Vdc	24 Vac	—	2	125	—	—	—	—	—	—	—
GLB166.1P	88 lb-in. (10 Nm)	0-10 Vdc	24 Vac	—	2	125	MN7510A2209	88 lb-in. (10 Nm)	On/Off, Floating, (0) 2-10 Vdc	24 Vac/Vdc (+20 / -15%)	(0) 2-10 Vdc	2 (5, 85)	95
GEB131.1U	132 lb-in. (15 Nm)	Floating	24 Vac	—	—	125	MN6120A1002	175 lb-in. (20 Nm)	On/Off, Floating	24 Vac (±15%), 24 Vdc	—	—	95

CROSS REFERENCE

Competitive Cross Reference

Direct Coupled Actuator

Siemens Model	Torque (lb.-in.)	Control Signal	Power	Feedback	Switches	Timing (sec)	Honeywell Actuator	Torque (lb.-in.)	Control Signal ^a	Power	Feedback ^a	Switches	Timing (sec)
GEB161.1U	132 lb.-in. (15 Nm)	0-10 Vdc	24 Vac	0-1k0hm	—	125	—	—	—	—	—	—	—
GEB132.1U	132 lb.-in. (15 Nm)	Floating	24 Vac	0-1k0hm	—	125	—	—	—	—	—	—	—
GEB136.1U	132 lb.-in. (15 Nm)	Floating	24 Vac	—	2	125	MN6120A1200	175 lb.-in. (20 Nm)	On/Off, Floating	24 Vac (±15%), 24 Vdc	—	2 (5, 85)	95
GEB164.1U	132 lb.-in. (15 Nm)	0-10 Vdc	24 Vac	0-1k0hm	2	125	—	—	—	—	—	—	—
GBB171.1U	177 lb.-in. (20 Nm)	On/Off, Floating	24 Vac	—	—	150	—	—	—	—	—	—	—
GBB171.1P	177 lb.-in. (20 Nm)	On/Off, Floating	24 Vac	—	—	150	MN6120A1002	175 lb.-in. (20 Nm)	On/Off, Floating	24 Vac (±15%), 24 Vdc	—	—	95
GBB161.1U	177 lb.-in. (20 Nm)	0-10 Vdc	24 Vac	—	—	150	—	—	—	—	—	—	—
GBB161.1P	177 lb.-in. (20 Nm)	0-10 Vdc	24 Vac	—	—	150	MN7220A2007	175 lb.-in. (20 Nm)	(0) 2-10 Vdc, (0) 4-20 mA	24 Vac (±20%), 24 Vdc	(0) 2-10 Vdc	—	95
GBB151.1U	177 lb.-in. (20 Nm)	4-20 mA	24 Vac	—	—	150	—	—	—	—	—	—	—
GBB151.1P	177 lb.-in. (20 Nm)	4-20 mA	24 Vac	—	—	150	MN7220A2007	175 lb.-in. (20 Nm)	(0) 2-10 Vdc, (0) 4-20 mA	24 Vac (±20%), 24 Vdc	(0) 2-10 Vdc	—	95
GBB175.1U	177 lb.-in. (20 Nm)	On/Off, Floating	24 Vac	0-1k0hm	—	150	—	—	—	—	—	—	—
GBB175.1P	177 lb.-in. (20 Nm)	On/Off, Floating	24 Vac	0-1k0hm	—	150	—	—	—	—	—	—	—
GBB166.1U	177 lb.-in. (20 Nm)	0-10 Vdc	24 Vac	—	2	150	—	—	—	—	—	—	—
GBB166.1P	177 lb.-in. (20 Nm)	0-10 Vdc	24 Vac	—	2	150	MN7220A2205	175 lb.-in. (20 Nm)	(0) 2-10 Vdc, (0) 4-20 mA	24 Vac (±20%), 24 Vdc	(0) 2-10 Vdc	2 (5, 85)	95
GBB156.1U	177 lb.-in. (20 Nm)	4-20 mA	24 Vac	—	2	150	—	—	—	—	—	—	—
GBB156.1P	177 lb.-in. (20 Nm)	4-20 mA	24 Vac	—	2	150	MN7220A2205	175 lb.-in. (20 Nm)	(0) 2-10 Vdc, (0) 4-20 mA	24 Vac (±20%), 24 Vdc	(0) 2-10 Vdc	2 (5, 85)	95
GIB131.1U	310 lb.-in. (35 Nm)	Floating	24 Vac	—	—	150	MN6134A1003	300 lb.-in. (34 Nm)	On/Off, Floating	24 Vac (±15%), 24 Vdc	—	—	95
GIB131.1P	310 lb.-in. (35 Nm)	Floating	24 Vac	—	—	150							
GIB132.1U	310 lb.-in. (35 Nm)	Floating	24 Vac	0-1k0hm	—	150	—	—	—	—	—	—	—
GIB132.1P	310 lb.-in. (35 Nm)	Floating	24 Vac	0-1k0hm	—	150	—	—	—	—	—	—	—
GIB136.1U	310 lb.-in. (35 Nm)	Floating	24 Vac	—	2	150	MN6134A1003 + SW2	300 lb.-in. (34 Nm)	On/Off, Floating	24 Vac (±15%), 24 Vdc	—	2 (Adjustable)	95
GIB136.1P	310 lb.-in. (35 Nm)	Floating	24 Vac	—	2	150							
GIB163.1U	310 lb.-in. (35 Nm)	0-10 Vdc	24 Vac	0-1k0hm	—	150	—	—	—	—	—	—	—
GIB163.1P	310 lb.-in. (35 Nm)	0-10 Vdc	24 Vac	0-1k0hm	—	150	—	—	—	—	—	—	—
GIB164.1U	310 lb.-in. (35 Nm)	0-10 Vdc	24 Vac	0-1k0hm	2	150	—	—	—	—	—	—	—
GIB164.1P	310 lb.-in. (35 Nm)	0-10 Vdc	24 Vac	0-1k0hm	2	150	—	—	—	—	—	—	—
GIB171.1U	310 lb.-in. (35 Nm)	On/Off, Floating	24 Vac	—	—	150	MN6134A1003	300 lb.-in. (34 Nm)	On/Off, Floating	24 Vac (±15%), 24 Vdc	—	—	95
GIB171.1P	310 lb.-in. (35 Nm)	On/Off, Floating	24 Vac	—	—	150							
GIB161.1U	310 lb.-in. (35 Nm)	0-10 Vdc	24 Vac	—	—	150	MN7234A2008	300 lb.-in. (34 Nm)	(0) 2-10 Vdc, (0) 4-20 mA	24 Vac (±20%), 24 Vdc	(0) 2-10 Vdc	—	95
GIB161.1P	310 lb.-in. (35 Nm)	0-10 Vdc	24 Vac	—	—	150							
GIB151.1U	310 lb.-in. (35 Nm)	4-20 mA	24 Vac	—	—	150	MN7234A2008	300 lb.-in. (34 Nm)	(0) 2-10 Vdc, (0) 4-20 mA	24 Vac (±20%), 24 Vdc	(0) 2-10 Vdc	—	95
GIB151.1P	310 lb.-in. (35 Nm)	4-20 mA	24 Vac	—	—	150							
GIB175.1U	310 lb.-in. (35 Nm)	On/Off, Floating	24 Vac	0-1k0hm	—	150	—	—	—	—	—	—	—

Competitive Cross Reference

Direct Coupled Actuator

Siemens Model	Torque (lb-in.)	Control Signal	Power	Feedback	Switches	Timing (sec)	Honeywell Actuator	Torque (lb-in.)	Control Signal ^a	Power	Feedback ^a	Switches	Timing (sec)
GIB175.1P	310 lb-in. (35 Nm)	On/Off, Floating	24 Vac	0-1k0hm	—	150	—	—	—	—	—	—	—
GIB166.1U	310 lb-in. (35 Nm)	0-10 Vdc	24 Vac	—	2	150	MN7234A2008 + SW2	300 lb-in. (34 Nm)	(0) 2-10 Vdc, (0) 4-20 mA	24 Vac (±20%), 24 Vdc	(0) 2-10 Vdc	2 (Adjustable)	95
GIB166.1P	310 lb-in. (35 Nm)	0-10 Vdc	24 Vac	—	2	150	—	—	—	—	—	—	—
GIB156.1U	310 lb-in. (35 Nm)	4-20 mA	24 Vac	—	2	150	MN7234A2008 + SW2	300 lb-in. (34 Nm)	(0) 2-10 Vdc, (0) 4-20 mA	24 Vac (±20%), 24 Vdc	(0) 2-10 Vdc	2 (Adjustable)	95
GIB156.1P	310 lb-in. (35 Nm)	4-20 mA	24 Vac	—	2	150							
GIB161.1P/MAS	310 lb-in. (35 Nm)	0-10 Vdc	24 Vac	0-1k0hm	—	150	—	—	—	—	—	—	—
GIB164.1P/MAS	310 lb-in. (35 Nm)	0-10 Vdc	24 Vac	0-1k0hm	2	150	—	—	—	—	—	—	—
GIB161.1P/SLA	310 lb-in. (35 Nm)	0-10 Vdc	24 Vac	—	—	150	—	—	—	—	—	—	—
—	—	—	—	—	—	—	MS4105A1002	44 lb-in. (5 Nm)	On/Off	100-250 Vac	—	—	45
—	—	—	—	—	—	—	MS7505A2008	44 lb-in. (5 Nm)	On/Off, Floating, (0) 2-10 Vdc	24 Vac (±20%), 24 Vdc	(0) 2-10 Vdc	—	90
—	—	—	—	—	—	—	MS8105A1008	44 lb-in. (5 Nm)	On/Off	24 Vac (±20%), 24 Vdc	—	—	45
—	—	—	—	—	—	—	MS7520H2208	175 lb-in. (20 Nm)	On/Off, Floating, (0) 2-10 Vdc	24 Vac (±20%), 24 Vdc	(0) 2-10 Vdc	2 (7, 85)	90
—	—	—	—	—	—	—	MS7510H2209	88 lb-in. (10 Nm)	On/Off, Floating, (0) 2-10 Vdc	24 Vac (±20%), 24 Vdc	(0) 2-10 Vdc	2 (7, 85)	90
GMA121.1U	62 lb-in. (7 Nm)	On/Off	24 Vac	—	—	90	MS8110A1008	88 lb-in. (10 Nm)	On/Off	24 Vac (±20%), 24 Vdc	—	—	45
GMA121.1P	62 lb-in. (7 Nm)	On/Off	24 Vac	—	—	90							
GMA121.1P/B	62 lb-in. (7 Nm)	On/Off	24 Vac	—	—	90							
GMA151.1U	62 lb-in. (7 Nm)	2-10 Vdc	24 Vac/ Vdc	0-1k0hm	—	90	ML7174A2001 + 200976C	70 lb-in. (8 Nm)	(0) 2-10 Vdc, (0) 4-20 mA	24 Vac/Vdc - 15%/+20%	0-2 k0hm	—	95
GMA151.1P	62 lb-in. (7 Nm)	2-10 Vdc	24 Vac/ Vdc	0-1k0hm	—	90							
GMA156.1U	62 lb-in. (7 Nm)	2-10 Vdc	24 Vac/ Vdc	0-1k0hm	2	90	—	—	—	—	—	—	—
GMA156.1P	62 lb-in. (7 Nm)	2-10 Vdc	24 Vac/ Vdc	0-1k0hm	2	90	—	—	—	—	—	—	—
GMA163.1U	62 lb-in. (7 Nm)	0-10 Vdc	24 Vac/ Vdc	0-1k0hm	—	90	—	—	—	—	—	—	—
GMA163.1P	62 lb-in. (7 Nm)	0-10 Vdc	24 Vac/ Vdc	0-1k0hm	—	90	—	—	—	—	—	—	—
GMA164.1U	62 lb-in. (7 Nm)	0-10 Vdc	24 Vac/ Vdc	0-1k0hm	2	90	—	—	—	—	—	—	—
GMA221.1U	62 lb-in. (7 Nm)	On/Off	120 Vac	—	—	90	MS4110A1002	88 lb-in. (10 Nm)	On/Off	100-250 Vac	—	—	45
GMA131.1U	62 lb-in. (7 Nm)	Floating	24 Vac/ Vdc	—	—	90	MS7510A2008	88 lb-in. (10 Nm)	On/Off, Floating, (0) 2-10 Vdc	24 Vac/Vdc - 15%/+20%	(0) 2-10 Vdc	—	90
GMA161.1U	62 lb-in. (7 Nm)	0-10 Vdc	24 Vac	0-1k0hm	—	90	—	—	—	—	—	—	—
GMA161.1P	62 lb-in. (7 Nm)	0-10 Vdc	24 Vac	0-1k0hm	—	90	—	—	—	—	—	—	—
GMA132.1U	62 lb-in. (7 Nm)	Floating	24 Vac	0-1k0hm	—	90	—	—	—	—	—	—	—
GMA126.1U	62 lb-in. (7 Nm)	On/Off	24 Vac	—	2	90	MS8110A1206	88 lb-in. (10 Nm)	On/Off	24 Vac (±20%), 24 Vdc	—	2 (7, 85)	45
GMA126.1P	62 lb-in. (7 Nm)	On/Off	24 Vac	—	2	90							
GMA226.1U	62 lb-in. (7 Nm)	On/Off	120 Vac	—	2	90	MS4110A1200	88 lb-in. (10 Nm)	On/Off	100-250 Vac	—	2 (7, 85)	45
GMA136.1U	62 lb-in. (7 Nm)	Floating	24 Vac	—	2	90	MS7510A2206	88 lb-in. (10 Nm)	On/Off, Floating, (0) 2-10 Vdc	24 Vac/Vdc - 15%/+20%	(0) 2-10 Vdc	2 (7, 85)	90

Competitive Cross Reference

Direct Coupled Actuator

Siemens Model	Torque (lb-in.)	Control Signal	Power	Feedback	Switches	Timing (sec)	Honeywell Actuator	Torque (lb-in.)	Control Signal ^a	Power	Feedback ^a	Switches	Timing (sec)
GMA166.1U	62 lb-in. (7 Nm)	0-10 Vdc	24 Vac	0-1k0hm	2	90	—	—	—	—	—	—	—
GMA166.1P	62 lb-in. (7 Nm)	0-10 Vdc	24 Vac	0-1k0hm	2	90	—	—	—	—	—	—	—
GCA121.1U	142 lb-in. (16 Nm)	On/Off	24 Vac	—	—	90	MS8120A1007	175 lb-in. (20 Nm)	On/Off	24 Vac (±20%), 24 Vdc	—	—	45
GCA121.1P	142 lb-in. (16 Nm)	On/Off	24 Vac	—	—	90							
GCA221.1U	142 lb-in. (16 Nm)	On/Off	120 Vac	—	—	90	MS4120A1001	175 lb-in. (20 Nm)	On/Off	100-250 Vac	—	—	45
GCA131.1U	142 lb-in. (16 Nm)	Floating	24 Vac	—	—	90	—	—	—	—	—	—	—
GCA131.1P	142 lb-in. (16 Nm)	Floating	24 Vac	—	—	90	—	—	—	—	—	—	—
GCA132.1U	142 lb-in. (16 Nm)	Floating	24 Vac/ Vdc	0-1k0hm	—	90	—	—	—	—	—	—	—
GCA132.1P	142 lb-in. (16 Nm)	Floating	24 Vac/ Vdc	0-1k0hm	—	90	—	—	—	—	—	—	—
GCA136.1U	142 lb-in. (16 Nm)	Floating	24 Vac/ Vdc	—	2	90	—	—	—	—	—	—	—
GCA136.1P	142 lb-in. (16 Nm)	Floating	24 Vac/ Vdc	—	2	90	—	—	—	—	—	—	—
GCA161.1U	142 lb-in. (16 Nm)	0-10 Vdc	24 Vac	—	—	90	—	—	—	—	—	—	—
GCA161.1P	142 lb-in. (16 Nm)	0-10 Vdc	24 Vac	—	—	90	—	—	—	—	—	—	—
GCA163.1U	142 lb-in. (16 Nm)	0-10 Vdc	24 Vac/ Vdc	0-1k0hm	—	90	—	—	—	—	—	—	—
GCA163.1P	142 lb-in. (16 Nm)	0-10 Vdc	24 Vac/ Vdc	0-1k0hm	—	90	—	—	—	—	—	—	—
GCA164.1U	142 lb-in. (16 Nm)	0-10 Vdc	24 Vac/ Vdc	0-1k0hm	2	90	—	—	—	—	—	—	—
GCA164.1P	142 lb-in. (16 Nm)	0-10 Vdc	24 Vac/ Vdc	0-1k0hm	2	90	—	—	—	—	—	—	—
GCA151.1U	142 lb-in. (16 Nm)	4-20 mA	24 Vac	—	—	90	MS7520A2007	175 lb-in. (20 Nm)	On/Off, Floating, (0) 2-10 Vdc	24 Vac (±20%), 24 Vdc	(0) 2-10 Vdc	—	90
GCA151.1P	142 lb-in. (16 Nm)	4-20 mA	24 Vac	—	—	90							
GCA126.1U	142 lb-in. (16 Nm)	On/Off	24 Vac	—	2	90	MS8120A1205	175 lb-in. (20 Nm)	On/Off	24 Vac (±20%), 24 Vdc	—	2 (7, 85)	45
GCA126.1P	142 lb-in. (16 Nm)	On/Off	24 Vac	—	2	90							
GCA226.1U	142 lb-in. (16 Nm)	On/Off	120 Vac	—	2	90	MS4120A1209	175 lb-in. (20 Nm)	On/Off	100-250 Vac	—	2 (7, 85)	45
GCA135.1U	142 lb-in. (16 Nm)	Floating	24 Vac	0-1k0hm	2	90	—	—	—	—	—	—	—
GCA135.1P	142 lb-in. (16 Nm)	Floating	24 Vac	0-1k0hm	2	90	—	—	—	—	—	—	—
GCA166.1U	142 lb-in. (16 Nm)	0-10 Vdc	24 Vac	—	2	90	MS7520A2205	175 lb-in. (20 Nm)	On/Off, Floating, (0) 2-10 Vdc	24 Vac (±20%), 24 Vdc	(0) 2-10 Vdc	2 (7, 85)	90
GCA166.1P	142 lb-in. (16 Nm)	0-10 Vdc	24 Vac	—	2	90							
GCA156.1U	142 lb-in. (16 Nm)	4-20 mA	24 Vac	—	2	90	MS7520A2205	175 lb-in. (20 Nm)	On/Off, Floating, (0) 2-10 Vdc	24 Vac (±20%), 24 Vdc	(0) 2-10 Vdc	2 (7, 85)	90

^a All models described as (0) 2-10 Vdc can be used with a 4-20 mA control input. Shunt a 500 ohm, 1/2 W resistor across the input at the actuator.

Control Ball Valve Cross Reference

2-Way Valve

Pipe Size	Cv	Siemens	Cv	Belimo	Cv	Invensys	Cv	Johnson Controls	Cv	Honeywell	
										Ni-Brass	Stainless Steel
1/2 in.	0.4	599-10203			0.38	VB-2213-500-9-01			0.38	VBN2AB3POX	VBN2AB3SOX
	0.63	599-10204			0.68	VB-2213-500-9-02			0.68	VBN2AD3POX	VBN2AD3SOX
	1.6	599-10205			1.3	VB-2213-500-9-03	1.2	VG1241AD	1.3	VBN2AE3POX	VBN2AE3SOX
	2.5	599-10206			2.6	VB-2213-500-9-04	2.9	VG1241AE	2	VBN2AF3POX	VBN2AF3SOX
	4	599-10207			4.7	VB-2213-500-9-05	4.7	VG1241AF	2.6	VBN2AG3POX	VBN2AG3SOX
					8	VB-2213-500-9-06	7.4	VG1241AG	4.7	VBN2AH3POX	VBN2AH3SOX
	10	599-10208			11.7	VB-2213-500-9-07	11.7	VG1241AL	8	VBN2AJ3POX	VBN2AJ3SOX
3/4 in.					0.31	VB-2213-500-9-11			0.31	VBN2AK3POX	VBN2AK3SOX
					0.63	VB-2213-500-9-12			0.63	VBN2BB3POX	VBN2BB3SOX
					1.2	VB-2213-500-9-13			1.2	VBN2BD3POX	VBN2BD3SOX
					2.5	VB-2213-500-9-14			2.5	VBN2BE3POX	VBN2BE3SOX
					4.3	VB-2213-500-9-15	4.7	VG1241BG	4.3	VBN2BG3POX	VBN2BG3SOX
							7.4	VG1241BH	4.3	VBN2BH3POX	VBN2BH3SOX
	10	599-10209			10.1	VB-2213-500-9-16	11.7	VG1241BL	7.4	VBN2BJ3POX	VBN2BJ3SOX
					14.7	VB-2213-500-9-17		VG1241BN	10.1	VBN2BK3POX	VBN2BK3SOX
	25	599-10210			28.6	VB-2213-500-9-18			14.7	VBN2BL3POX	VBN2BL3SOX
					4.4	VB-2213-500-9-21	7.4	VG1241CL	4.4	VBN2BM3POX	VBN2BM3SOX
1 in.	10	599-10211			9.0	VB-2213-500-9-22	11.7	VG1241CN	9.0	VBN2CM3POX	VBN2CM3SOX
	16	599-10213			15.3	VB-2213-500-9-23	18.7	VG1241CP	15.3	VBN2CH3POX	VBN2CH3SOX
	25	599-10212			26.1	VB-2213-500-9-24			26	VBN2CJ3POX	VBN2CJ3SOX
					43.9	VB-2213-500-9-26			44	VBN2CK3POX	VBN2CK3SOX
	63	599-10214			54.2	VB-2213-500-9-27			54	VBN2CN3POX	VBN2CN3SOX
1-1/4 in.					4.4	VB-2213-500-9-41			4.4	VBN2CP3POX	VBN2CP3SOX
					8.3	VB-2213-500-9-42	11.7	VG1241DN	8.3	VBN2DH3POX	VBN2DH3SOX
	16	599-10215			14.9	VB-2213-500-9-43	18.7	VG1241DP	14.9	VBN2DJ3POX	VBN2DJ3SOX
							29.2	VG1241DR	25.0	VBN2DK3POX	VBN2DK3SOX
					36.5	VB-2213-500-9-44			37	VBN2DL3POX	VBN2DL3SOX
	40	599-10216			41.1	VB-2213-500-9-45			41	VBN2DM3POX	VBN2DM3SOX
	100	599-10217			102.3	VB-2213-500-9-46			102	VBN2DN3POX	VBN2DN3SOX
1-1/2 in.	25	599-10218			22.8	VB-2213-500-9-51	18.7	VG1241EP	23	VBN2DS3POX	VBN2DS3SOX
							29.2	VG1241ER	30.0	VBN2EL3POX	VBN2EL3SOX
	40	599-10220			41.3	VB-2213-500-9-52	46.8	VG1241ES	41	VBN2EM3POX	VBN2EM3SOX
	63	599-10219			73.9	VB-2213-500-9-53			74	VBN2EN3POX	VBN2EN3SOX
	160	599-10221			171.7	VB-2213-500-9-54			172	VBN2ER3POX	VBN2ER3SOX
							29.2	VG1241FR		172	VBN2E13POX
2 in.	40	599-10222			41.7	VB-2213-500-9-61	46.8	VG1241FS	42	VBN2FN3POX	VBN2FN3SOX
	63	599-10224							57.0	VBN2FP3POX	VBN2FP3SOX
					71.1	VB-2213-500-9-63	73.7	VG1241FT	71	VBN2FR3POX	VBN2FR3SOX
	100	599-10223							100.0	VBN2FS3POX	VBN2FS3SOX
					108.0	VB-2213-500-9-65			108.0	VBN2FT3POX	VBN2FT3SOX
	250	599-10225			210.0	VB-2213-500-9-66			210.0	VBN2F13POX	VBN2F13SOX
2-1/2 in.					266	VB-2213-500-9-67			266.0	VBN2F23POX	VBN2F23SOX
					45.0	VB-2213-500-9-71			45.0	VBN2GN3POX	VBN2GN3SOX
					55.0	VB-2213-500-9-72			55.0	VBN2GP3POX	VBN2GP3SOX
					72.3	VB-2213-500-9-73			72	VBN2GR3POX	VBN2GR3SOX
					101.0	VB-2213-500-9-74			101.0	VBN2GS3POX	VBN2GS3SOX
					162.0	VB-2213-500-9-75			162.0	VBN2GU3POX	VBN2GU3SOX
					202.0	VB-2213-500-9-76			202.0	VBN2G13POX	VBN2G13SOX
3 in.					49.0	VB-2213-500-9-81			49.0	VBN2HN3POX	VBN2HN3SOX
					63.0	VB-2213-500-9-82			63.0	VBN2HP3POX	VBN2HP3SOX
					82.0	VB-2213-500-9-83			82.0	VBN2HR3POX	VBN2HR3SOX
					124.0	VB-2213-500-9-84			124.0	VBN2HT3POX	VBN2HT3SOX
					145.0	VB-2213-500-9-85			145.0	VBN2HU3POX	VBN2HU3SOX
4 in.									91.0	VBN2J13POX	VBN2J13SOX
									118.0	VBN2J23POX	VBN2J23SOX
									152.0	VBN2J33POX	VBN2J33SOX
									197.0	VBN2J43POX	VBN2J43SOX
									254.0	VBN2J53POX	VBN2J53SOX
5 in.									144.0	VBN2K13POX	VBN2K13SOX
									185.0	VBN2K23POX	VBN2K23SOX
									240.0	VBN2K33POX	VBN2K33SOX
									309.0	VBN2K43POX	VBN2K43SOX
									400.0	VBN2K53POX	VBN2K53SOX
6 in.									208.0	VBN2L13POX	VBN2L13SOX
									268.0	VBN2L23POX	VBN2L23SOX
									346.0	VBN2L33POX	VBN2L33SOX
									441.0	VBN2L43POX	VBN2L43SOX
									577.0	VBN2L53POX	VBN2L53SOX
									650.0	VBN2L63POX	VBN2L63SOX

Control Ball Valve Cross Reference

2-Way Valve + Non-Spring Return Floating Actuator

Pipe Size	Cv	Siemens	Cv	Belimo	Cv	Invensys	Cv	Johnson Controls	Cv	Honeywell		
										Ni-Brass	Stainless Steel	
1/2 in.			0.3	B207+LRB24-3								
	0.4	171A-10203	0.46	B208+LRB24-3	0.38	VF-2213-505-9-01			0.38	VBN2AB3POA	VBN2AB3SOA	
	0.63	171A-10204	0.8	B209+LRB24-3	0.68	VF-2213-505-9-02			0.68	VBN2AD3POA	VBN2AD3SOA	
	1.6	171A-10205	1.2	B210+LRB24-3	1.3	VF-2213-505-9-03			1.3	VBN2AE3POA	VBN2AE3SOA	
			1.9	B211+LRB24-3				1.9	VG1241AD - 9T4AGA	2	VBN2AF3POA	VBN2AF3SOA
	2.5	171A-10206	3	B212+LRB24-3	2.6	VF-2213-505-9-04	2.9	VG1241AF - 9T4AGA	2.6	VBN2AG3POA	VBN2AG3SOA	
	4	171A-10207	4.7	B213+LRB24-3	4.7	VF-2213-505-9-05	4.7	VG1241AG - 9T4AGA	4.7	VBN2AH3POA	VBN2AH3SOA	
			7.4	B214+LRB24-3	8	VF-2213-505-9-06	7.4	VG1241AL - 9T4AGA	8	VBN2AJ3POA	VBN2AJ3SOA	
	10	171A-10208	10	B215+LRB24-3	11.7	VF-2213-505-9-07	11.7	VG1241AN - 9T4AGA	11.7	VBN2AK3POA	VBN2AK3SOA	
3/4 in.					0.31	VF-2213-505-9-11			0.31	VBN2BB3POA	VBN2BB3SOA	
					0.63	VF-2213-505-9-12			0.63	VBN2BD3POA	VBN2BD3SOA	
					1.2	VF-2213-505-9-13			1.2	VBN2BE3POA	VBN2BE3SOA	
					2.5	VF-2213-505-9-14			2.5	VBN2BG3POA	VBN2BG3SOA	
			4.7	B217+LRB24-3	4.3	VF-2213-505-9-15	4.7	VG1241BG - 9T4AGA	4.3	VBN2BH3POA	VBN2BH3SOA	
			7.4	B218+LRB24-3			7.4	VG1241BL - 9T4AGA	7.4	VBN2BJ3POA	VBN2BJ3SOA	
	10	171A-10209	10	B219+LRB24-3	10.1	VF-2213-505-9-16	11.7	VG1241BN - 9T4AGA	10.1	VBN2BK3POA	VBN2BK3SOA	
			24	B220+LRB24-3	28.6	VF-2213-505-9-18			29	VBN2BL3POA	VBN2BL3SOA	
1 in.			7.4	B222+LRB24-3	4.4	VF-2213-505-9-21	7.4	VG1241CL - 9T4AGA	4.4	VBN2CH3POA	VBN2CH3SOA	
	10	171A-10211	10	B223+LRB24-3	9.0	VF-2213-505-9-22	11.7	VG1241CN - 9T4AGA	9.0	VBN2CJ3POA	VBN2CJ3SOA	
	16	171A-10213	19	B224+LRB24-3	15.3	VF-2213-505-9-23	18.7	VG1241CP - 9T4AGA	15.3	VBN2CL3POA	VBN2CL3SOA	
	25	171A-10212	30	B225+LRB24-3	26.1	VF-2213-505-9-24			26	VBN2CM3POA	VBN2CM3SOA	
					43.9	VF-2213-505-9-26			44	VBN2CN3POA	VBN2CN3SOA	
					54.2	VF-2213-505-9-27			54	VBN2CP3POA	VBN2CP3SOA	
					4.4	VF-2213-505-9-41			4.4	VBN2DH3POA	VBN2DH3SOA	
			10	B229+LRB24-3	8.3	VF-2213-505-9-42	11.7	VG1241DN - 906AGA	8.3	VBN2DJ3POA	VBN2DJ3SOA	
1-1/4 in.	16	171A-10215	19	B230+LRB24-3	14.9	VF-2213-505-9-43	18.7	VG1241DP - 906AGA	14.9	VBN2DK3POA	VBN2DK3SOA	
			25	B231+ARB24-3			29.2	VG1241DR - 906AGA	25.0	VBN2DL3POA	VBN2DL3SOA	
			37	B232+ARB24-3	36.5	VF-2213-505-9-44			37	VBN2DM3POA	VBN2DM3SOA	
	40	171A-10216			41.1	VF-2213-505-9-45			41	VBN2DN3POA	VBN2DN3SOA	
	100	171A-10217			102.3	VF-2213-505-9-46			102	VBN2DS3POA	VBN2DS3SOA	
	25	171B-10218	19	B238+ARB24-3	22.8	VF-2213-505-9-51	18.7	VG1241EP - 906AGA	23	VBN2EL3POA	VBN2EL3SOA	
			29	B239+ARB24-3			29.2	VG1241ER - 906AGA	30.0	VBN2EM3POA	VBN2EM3SOA	
	40	171B-10220	37	B240+ARB24-3	41.3	VF-2213-505-9-52	46.8	VG1241ES - 906AGA	41	VBN2EN3POA	VBN2EN3SOA	
1-1/2 in.	63	171B-10219			73.9	VF-2213-505-9-53			74	VBN2ER3POA	VBN2ER3SOA	
	160	171B-10221			171.7	VF-2213-505-9-54			172	VBN2E13POA	VBN2E13SOA	
			29	B248+ARB24-3			29.2	VG1241FR - 909AGA				
	40	171B-10222	46	B249+ARB24-3	41.7	VF-2213-505-9-61	46.8	VG1241FS - 909AGA	42	VBN2FN3POA	VBN2FN3SOA	
	63	171B-10224	57	B250+ARB24-3					57.0	VBN2FP3POA	VBN2FP3SOA	
			65	B251+ARB24-3	71.1	VF-2213-505-9-63	73.7	VG1241FT - 909AGA	71	VBN2FR3POA	VBN2FR3SOA	
	100	171B-10223	85	B252+ARB24-3	108.0	VF-2213-505-9-65			100.0	VBN2FS3POA	VBN2FS3SOA	
			120	B253+ARB24-3					108.0	VBN2FT3POA	VBN2FT3SOA	
2 in.					210.0	VF-2213-505-9-66			210.0	VBN2F13POA	VBN2F13SOA	
	250	171B-10225	240	B254+ARB24-3	266	VF-2213-505-9-67			266.0	VBN2F23POA	VBN2F23SOA	
					45.0	VF-2213-505-9-71			45.0	VBN2GN3POA	VBN2GN3SOA	
			60	B261+ARB24-3	55.0	VF-2213-505-9-72			55.0	VBN2GP3POA	VBN2GP3SOA	
			75	B262+ARB24-3	72.3	VF-2213-505-9-73			72	VBN2GR3POA	VBN2GR3SOA	
			110	B263+ARB24-3	101.0	VF-2213-505-9-74			101.0	VBN2GS3POA	VBN2GS3SOA	
			150	B264+ARB24-3	162.0	VF-2213-505-9-75			162.0	VBN2GU3POA	VBN2GU3SOA	
			210	B265+ARB24-3	202.0	VF-2213-505-9-76			202.0	VBN2G13POA	VBN2G13SOA	
3 in.					49.0	VF-2213-505-9-81			49.0	VBN2HN3POA	VBN2HN3SOA	
			70	B277+ARB24-3	63.0	VF-2213-505-9-82			63.0	VBN2HP3POA	VBN2HP3SOA	
					82.0	VF-2213-505-9-83			82.0	VBN2HR3POA	VBN2HR3SOA	
			130	B278+ARB24-3	124.0	VF-2213-505-9-84			124.0	VBN2HT3POA	VBN2HT3SOA	
			170	B280+ARB24-3	145.0	VF-2213-505-9-85			145.0	VBN2HU3POA	VBN2HU3SOA	
									91.0		VBF2JS1SOA	
									118.0		VBF2JT1SOA	
									152.0		VBF2JU1SOA	
4 in.									197.0		VBF2J11SOA	
									254.0		VBF2J21SOA	
									144.0		VBF2KU1SOA	
									185.0		VBF2K11SOA	
									240.0		VBF2K21SOA	
									309.0		VBF2K31SOA	
									400.0		VBF2K41SOA	
									208.0		VBF2L11SOA	
5 in.									268.0		VBF2L21SOA	
									346.0		VBF2L41SOA	
									441.0		VBF2L51SOA	
									577.0		VBF2L61SOA	
									650.0		VBF2L71SOA	
6 in.												

CROSS REFERENCE

Control Ball Valve Cross Reference

2-Way Valve + Non-Spring Return Modulating Actuator

Pipe Size	Cv	Siemens		Belimo		Invensys		Johnson Controls		Honeywell			
		Cv		Cv		Cv		Cv		Ni-Brass	Stainless Steel		
1/2 in.			0.3		B207+LRB24-SR								
	0.4	171C-10203	0.46		B208+LRB24-SR	0.38	VS-2213-505-9-01			0.38	VBN2AB3POB	VBN2AB3SOB	
	0.63	171C-10204	0.8		B209+LRB24-SR	0.68	VS-2213-505-9-02			0.68	VBN2AD3POB	VBN2AD3SOB	
	1.6	171C-10205	1.2		B210+LRB24-SR	1.3	VS-2213-505-9-03			1.2	VBN2AE3POB	VBN2AE3SOB	
				1.9		B211+LRB24-SR			1.9	VG1241AD - 9T4GGA	2	VBN2AF3POB	VBN2AF3SOB
	2.5	171C-10206	3		B212+LRB24-SR	2.6	VS-2213-505-9-04	2.9	VG1241AF - 9T4GGA	2.6	VBN2AG3POB	VBN2AG3SOB	
	4	171C-10207	4.7		B213+LRB24-SR	4.7	VS-2213-505-9-05	4.7	VG1241AG - 9T4GGA	4.7	VBN2AH3POB	VBN2AH3SOB	
3/4 in.					B214+LRB24-SR	8	VS-2213-505-9-06	7.4	VG1241AL - 9T4GGA	8	VBN2AJ3POB	VBN2AJ3SOB	
	10	171C-10208	10		B215+LRB24-SR	11.7	VS-2213-505-9-07	11.7	VG1241AN - 9T4GGA	11.7	VBN2AK3POB	VBN2AK3SOB	
						0.31	VS-2213-505-9-11			0.31	VBN2BB3POB	VBN2BB3SOB	
						0.63	VS-2213-505-9-12			0.63	VBN2BD3POB	VBN2BD3SOB	
						1.2	VS-2213-505-9-13			1.2	VBN2BE3POB	VBN2BE3SOB	
						2.5	VS-2213-505-9-14			2.5	VBN2BG3POB	VBN2BG3SOB	
				4.7		B217+LRB24-SR	4.3	VS-2213-505-9-15	4.7	VG1241BG - 9T4GGA	4.3	VBN2BH3POB	VBN2BH3SOB
1 in.					B218+LRB24-SR			7.4	VG1241BL - 9T4GGA	7.4	VBN2BJ3POB	VBN2BJ3SOB	
	10	171C-10209	10		B219+LRB24-SR	10.1	VS-2213-505-9-16	11.7	VG1241BN - 9T4GGA	10.1	VBN2BK3POB	VBN2BK3SOB	
						14.7	VS-2213-505-9-17			14.7	VBN2BL3POB	VBN2BL3SOB	
	25	171C-10210	24		B220+LRB24-SR	28.6	VS-2213-505-9-18			29	VBN2BM3POB	VBN2BM3SOB	
						4.4	VS-2213-505-9-21	7.4	VG1241CL - 9T4GGA	4.4	VBN2CH3POB	VBN2CH3SOB	
	10	171C-10211	10		B223+LRB24-SR	9.0	VS-2213-505-9-22	11.7	VG1241CN - 9T4GGA	9.0	VBN2CJ3POB	VBN2CJ3SOB	
	16	171C-10213	19		B224+LRB24-SR	15.3	VS-2213-505-9-23	18.7	VG1241CP - 9T4GGA	15.3	VBN2CL3POB	VBN2CL3SOB	
1-1/4 in.	25	171C-10212	30		B225+LRB24-SR	26.1	VS-2213-505-9-24			26	VBN2CM3POB	VBN2CM3SOB	
						43.9	VS-2213-505-9-26			44	VBN2CN3POB	VBN2CN3SOB	
						54.2	VS-2213-505-9-27			54	VBN2CP3POB	VBN2CP3SOB	
	63	171C-10214				4.4	VS-2213-505-9-41			4.4	VBN2DH3POB	VBN2DH3SOB	
				10		B229+LRB24-SR	8.3	VS-2213-505-9-42	11.7	VG1241DN - 906GGA	8.3	VBN2DJ3POB	VBN2DJ3SOB
	16	171C-10215	19		B230+LRB24-SR	14.9	VS-2213-505-9-43	18.7	VG1241DP - 906GGA	14.9	VBN2DK3POB	VBN2DK3SOB	
				25		B231+ARB24-SR			29.2	VG1241DR - 906GGA	25.0	VBN2DL3POB	VBN2DL3SOB
1-1/2 in.	40	171C-10216	37		B232+ARB24-SR	36.5	VS-2213-505-9-44			37	VBN2DM3POB	VBN2DM3SOB	
						41.1	VS-2213-505-9-45			41	VBN2DN3POB	VBN2DN3SOB	
	100	171C-10217				102.3	VS-2213-505-9-46			102	VBN2DS3POB	VBN2DS3SOB	
	25	171D-10218	19		B238+ARB24-SR	22.8	VS-2213-505-9-51	18.7	VG1241EP - 906GGA	23	VBN2EL3POB	VBN2EL3SOB	
2 in.					B239+ARB24-SR			29.2	VG1241ER - 906GGA	30.0	VBN2EM3POB	VBN2EM3SOB	
	40	171D-10220	37		B240+ARB24-SR	41.3	VS-2213-505-9-52	46.8	VG1241ES - 906GGA	41	VBN2EN3POB	VBN2EN3SOB	
	63	171D-10219				73.9	VS-2213-505-9-53			74	VBN2ER3POB	VBN2ER3SOB	
	160	171D-10221				171.7	VS-2213-505-9-54			172	VBN2E13POB	VBN2E13SOB	
2-1/2 in.					B248+ARB24-SR			29.2	VG1241FR - 909GGA				
	40	171D-10222	46		B249+ARB24-SR	41.7	VS-2213-505-9-61	46.8	VG1241FS - 909GGA	42	VBN2FN3POB	VBN2FN3SOB	
	63	171D-10224	57		B250+ARB24-SR					57.0	VBN2FP3POB	VBN2FP3SOB	
					B251+ARX24-MFT	71.1	VS-2213-505-9-63	73.7	VG1241FT - 909GGA	71	VBN2FR3POB	VBN2FR3SOB	
	100	171D-10223	85		B252+ARX24-MFT					100.0	VBN2FS3POB	VBN2FS3SOB	
					B253+ARX24-MFT	108.0	VS-2213-505-9-65			108.0	VBN2FT3POB	VBN2FT3SOB	
						210.0	VS-2213-505-9-66			210.0	VBN2F13POB	VBN2F13SOB	
3 in.	250	171D-10225	240		B254+ARX24-MFT	266	VS-2213-505-9-67			266.0	VBN2F23POB	VBN2F23SOB	
						45.0	VS-2213-505-9-71			45.0	VBN2GN3POB	VBN2GN3SOB	
					B261+ARX24-MFT	55.0	VS-2213-505-9-72			55.0	VBN2GP3POB	VBN2GP3SOB	
					B262+ARX24-MFT	72.3	VS-2213-505-9-73			72	VBN2GR3POB	VBN2GR3SOB	
					B263+ARX24-MFT	101.0	VS-2213-505-9-74			101.0	VBN2GS3POB	VBN2GS3SOB	
					B264+ARX24-MFT	162.0	VS-2213-505-9-75			162.0	VBN2GU3POB	VBN2GU3SOB	
4 in.					B265+ARX24-MFT	202.0	VS-2213-505-9-76			202.0	VBN2G13POB	VBN2G13SOB	
						49.0	VS-2213-505-9-81			49.0	VBN2HN3POB	VBN2HN3SOB	
					B277+ARX24-MFT	63.0	VS-2213-505-9-82			63.0	VBN2HP3POB	VBN2HP3SOB	
						82.0	VS-2213-505-9-83			82.0	VBN2HR3POB	VBN2HR3SOB	
					B278+ARX24-MFT	124.0	VS-2213-505-9-84			124.0	VBN2HT3POB	VBN2HT3SOB	
5 in.					B280+ARX24-MFT	145.0	VS-2213-505-9-85			145.0	VBN2HU3POB	VBN2HU3SOB	
										91.0		VB2JUS1SOB	
										118.0		VB2JUS1SOB	
										152.0		VB2JUS1SOB	
										197.0		VB2JUS1SOB	
6 in.										254.0		VB2JUS1SOB	
										144.0		VB2JUS1SOB	
										185.0		VB2JUS1SOB	
										240.0		VB2JUS1SOB	
										309.0		VB2JUS1SOB	
									400.0		VB2JUS1SOB		
									208.0		VB2JUS1SOB		
									268.0		VB2JUS1SOB		
									346.0		VB2JUS1SOB		
									441.0		VB2JUS1SOB		
									577.0		VB2JUS1SOB		
									650.0		VB2JUS1SOB		

Control Ball Valve Cross Reference

2-Way Valve + Spring Return Floating Actuator

Pipe Size	Cv	Siemens		Belimo		Invensys		Johnson Controls		Honeywell			
		Cv		Cv		Cv		Cv		Ni-Brass	Stainless Steel		
1/2 in.			0.3		B207+TF24-3 US								
	0.4	171F-10203	0.46		B208+TF24-3 US	0.38	VF-2213-536-9-01			0.38	VBN2AB3POD	VBN2AB3SOD	
	0.63	171F-10204	0.8		B209+TF24-3 US	0.68	VF-2213-536-9-02			0.68	VBN2AD3POD	VBN2AD3SOD	
	1.6	171F-10205	1.2		B210+TF24-3 US	1.3	VF-2213-536-9-03			1.2	VBN2AE3POD	VBN2AE3SOD	
				1.9		B211+TF24-3 US			1.9	VG1241AE - 22TAGA	2	VBN2AF3POD	VBN2AF3SOD
	2.5	171F-10206	3		B212+TF24-3 US	2.6	VF-2213-536-9-04	2.9	VG1241AF - 22TAGA	2.6	VBN2AG3POD	VBN2AG3SOD	
	4	171F-10207	4.7		B213+TF24-3 US	4.7	VF-2213-536-9-05	4.7	VG1241AG - 22TAGA	4.7	VBN2AH3POD	VBN2AH3SOD	
3/4 in.						8	VF-2213-536-9-06	7.4	VG1241AL - 22TAGA	8	VBN2AJ3POD	VBN2AJ3SOD	
	10	171F-10208	10		B215+TF24-3 US	11.7	VF-2213-536-9-07	11.7	VG1241AN - 22TAGA	11.7	VBN2AK3POD	VBN2AK3SOD	
						0.31	VF-2213-536-9-11			0.31	VBN2BB3POD	VBN2BB3SOD	
						0.63	VF-2213-536-9-12			0.63	VBN2BD3POD	VBN2BD3SOD	
						1.2	VF-2213-536-9-13			1.2	VBN2BE3POD	VBN2BE3SOD	
						2.5	VF-2213-536-9-14			2.5	VBN2BG3POD	VBN2BG3SOD	
				4.7		B217+TF24-3 US	4.3	VF-2213-536-9-15	4.7	VG1241BG - 22TAGA	4.3	VBN2BH3POD	VBN2BH3SOD
1 in.						7.4	VF-2213-536-9-16	7.4	VG1241BL - 22TAGA	7.4	VBN2BJ3POD	VBN2BJ3SOD	
	10	171F-10209	10		B219+TF24-3 US	10.1	VF-2213-536-9-16	11.7	VG1241BN - 22TAGA	10.1	VBN2BK3POD	VBN2BK3SOD	
	25	171F-10210	24		B220+TF24-3 US	28.6	VF-2213-536-9-18			29	VBN2BL3POD	VBN2BL3SOD	
				7.4		B222+LF24-3 US	4.4	VF-2213-536-9-21	7.4	VG1241CL - 936AGA	4.4	VBN2CH3POD	VBN2CH3SOD
	10	171F-10211	10		B223+LF24-3 US	9.0	VF-2213-536-9-22	11.7	VG1241CN - 936AGA	9.0	VBN2CJ3POD	VBN2CJ3SOD	
	16	171F-10213	19		B224+LF24-3 US	15.3	VF-2213-536-9-23	18.7	VG1241CP - 936AGA	15.3	VBN2CL3POD	VBN2CL3SOD	
	25	171F-10212	30		B225+LF24-3 US	26.1	VF-2213-536-9-24			26	VBN2CM3POD	VBN2CM3SOD	
1-1/4 in.						43.9	VF-2213-536-9-26			44	VBN2CN3POD	VBN2CN3SOD	
	63	171F-10214				54.2	VF-2213-536-9-27			54	VBN2CP3POD	VBN2CP3SOD	
						4.4	VF-2213-536-9-41			4.4	VBN2DH3POD	VBN2DH3SOD	
				10		B229+LF24-3 US	8.3	VF-2213-536-9-42	11.7	VG1241DN - 936AGA	8.3	VBN2DJ3POD	VBN2DJ3SOD
	16	171F-10215	19		B230+LF24-3 US	14.9	VF-2213-536-9-43	18.7	VG1241DP - 936AGA	14.9	VBN2DK3POD	VBN2DK3SOD	
									29.2	VG1241DR - 936AGA	25.0	VBN2DL3POD	VBN2DL3SOD
							36.5	VF-2213-536-9-44			37	VBN2DM3POD	VBN2DM3SOD
1-1/2 in.	40	171F-10216				41.1	VF-2213-536-9-45			41	VBN2DN3POD	VBN2DN3SOD	
	100	171F-10217				102.3	VF-2213-536-9-46			102	VBN2DS3POD	VBN2DS3SOD	
	25	171F-10218				22.8	VF-2213-536-9-51	18.7	VG1241EP - 936AGA	23	VBN2EL3POD	VBN2EL3SOD	
	40	171F-10220				41.3	VF-2213-536-9-52	46.8	VG1241ER - 936AGA	30.0	VBN2EM3POD	VBN2EM3SOD	
	63	171F-10219				73.9	VF-2213-536-9-53			41	VBN2EN3POD	VBN2EN3SOD	
	160	171F-10221				171.7	VF-2213-536-9-54			74	VBN2ER3POD	VBN2ER3SOD	
										172	VBN2E13POD	VBN2E13SOD	
2 in.								29.2	VG1241FR - 926AGA				
	40	171F-10222				41.7	VF-2213-536-9-61	46.8	VG1241FS - 926AGA	42	VBN2FN3POD	VBN2FN3SOD	
	63	171F-10224								57.0	VBN2FP3POD	VBN2FP3SOD	
	100	171F-10223				71.1	VF-2213-536-9-63	73.7	VG1241FT - 926AGA	71	VBN2FR3POD	VBN2FR3SOD	
										100.0	VBN2FS3POD	VBN2FS3SOD	
							108.0	VF-2213-536-9-65			108.0	VBN2FT3POD	VBN2FT3SOD
							210.0	VF-2213-536-9-66			210.0	VBN2F13POD	VBN2F13SOD
2-1/2 in.						266	VF-2213-536-9-67			266.0	VBN2F23POD	VBN2F23SOD	
						45.0	VF-2213-536-9-71			45.0	VBN2GN3POD	VBN2GN3SOD	
						55.0	VF-2213-536-9-72			55.0	VBN2GP3POD	VBN2GP3SOD	
						72.3	VF-2213-536-9-73			72	VBN2GR3POD	VBN2GR3SOD	
						101.0	VF-2213-536-9-74			101.0	VBN2GS3POD	VBN2GS3SOD	
						162.0	VF-2213-536-9-75			162.0	VBN2GU3POD	VBN2GU3SOD	
						202.0	VF-2213-536-9-76			202.0	VBN2G13POD	VBN2G13SOD	
3 in.						49.0	VF-2213-536-9-81			49.0	VBN2HN3POD	VBN2HN3SOD	
						63.0	VF-2213-536-9-82			63.0	VBN2HP3POD	VBN2HP3SOD	
						82.0	VF-2213-536-9-83			82.0	VBN2HR3POD	VBN2HR3SOD	
						124.0	VF-2213-536-9-84			124.0	VBN2HT3POD	VBN2HT3SOD	
						145.0	VF-2213-536-9-85			145.0	VBN2HU3POD	VBN2HU3SOD	
4 in.										91.0		VB2JUS1SOD	
										118.0		VB2JT1SOD	
										152.0		VB2JU1SOD	
										197.0		VB2J11SOD	
										254.0		VB2J21SOD	
5 in.										144.0		VB2KU1SOD	
										185.0		VB2K11SOD	
										240.0		VB2K21SOD	
										309.0		VB2K31SOD	
										400		VB2K41SOD	
6 in.										208.0		VB2L11SOD	
										268.0		VB2L21SOD	
										346		VB2L41SOD	
										441		VB2L51SOD	
										577		VB2L61SOD	
									650		VB2L71SOD		

Control Ball Valve Cross Reference

2-Way Valve + Spring Return Modulating Actuator

Pipe Size	Cv	Siemens		Belimo		Invensys		Johnson Controls		Honeywell		
		Cv		Cv		Cv		Cv		Ni-Brass	Stainless Steel	
1/2 in.			0.3	B207+TF24-SR US								
	0.4	171G-10203	0.46	B208+TF24-SR US	0.38	VS-2213-536-9-01			0.38	VBN2AB3POD	VBN2AB3SOD	
	0.63	171G-10204	0.8	B209+TF24-SR US	0.68	VS-2213-536-9-02			0.68	VBN2AD3POD	VBN2AD3SOD	
	1.6	171G-10205	1.2	B210+TF24-SR US	1.3	VS-2213-536-9-03			1.2	VBN2AE3POD	VBN2AE3SOD	
				1.9	B211+TF24-SR US				1.9	VBN2AF3POD	VBN2AF3SOD	
	2.5	171G-10206	3	B212+TF24-SR US	2.6	VS-2213-536-9-04			2.9	VBN2AG3POD	VBN2AG3SOD	
	4	171G-10207	4.7	B213+TF24-SR US	4.7	VS-2213-536-9-05			4.7	VBN2AH3POD	VBN2AH3SOD	
3/4 in.			7.4	B214+TF24-SR US	8	VS-2213-536-9-06			7.4	VBN2AJ3POD	VBN2AJ3SOD	
	10	171G-10208	10	B215+TF24-SR US	11.7	VS-2213-536-9-07			11.7	VBN2AK3POD	VBN2AK3SOD	
									0.31	VBN2BB3POD	VBN2BB3SOD	
						0.31	VS-2213-536-9-11			0.63	VBN2BD3POD	VBN2BD3SOD
						0.63	VS-2213-536-9-12			1.2	VBN2BE3POD	VBN2BE3SOD
						1.2	VS-2213-536-9-13			2.5	VBN2BG3POD	VBN2BG3SOD
				4.7	B217+TF24-SR US	2.5	VS-2213-536-9-14	4.7	VG1241BG - 22TBGA	4.3	VBN2BH3POD	VBN2BH3SOD
1 in.			7.4	B218+TF24-SR US	4.3	VS-2213-536-9-15	7.4	VG1241BL - 22TBGA	7.4	VBN2BJ3POD	VBN2BJ3SOD	
	10	171G-10209	10	B219+TF24-SR US	10.1	VS-2213-536-9-16	11.7	VG1241BN - 22TBGA	10.1	VBN2BK3POD	VBN2BK3SOD	
									14.7	VBN2BL3POD	VBN2BL3SOD	
									29	VBN2BM3POD	VBN2BM3SOD	
				24	B220+TF24-SR US	28.6	VS-2213-536-9-18			4.4	VBN2CH3POD	VBN2CH3SOD
				7.4	B222+LF24-SR US	4.4	VS-2213-536-9-21	7.4	VG1241CL - 936GGA	4.4	VBN2CN3POD	VBN2CN3SOD
	10	171G-10211	10	B223+LF24-SR US	9.0	VS-2213-536-9-22	11.7	VG1241CN - 22TBGA	9.0	VBN2CJ3POD	VBN2CJ3SOD	
1-1/4 in.	16	171G-10213	19	B224+LF24-SR US	15.3	VS-2213-536-9-23	18.7	VG1241CP - 22TBGA	15.3	VBN2CL3POD	VBN2CL3SOD	
	25	171G-10212	30	B225+LF24-SR US	26.1	VS-2213-536-9-24			26	VBN2CM3POD	VBN2CM3SOD	
									44	VBN2CN3POD	VBN2CN3SOD	
									54	VBN2CP3POD	VBN2CP3SOD	
									4.4	VBN2DH3POD	VBN2DH3SOD	
									4.4	VBN2DH3POD	VBN2DH3SOD	
				10	B229+LF24-SR US	8.3	VS-2213-536-9-42	11.7	VG1241DN - 906GA	8.3	VBN2DJ3POD	VBN2DJ3SOD
1-1/2 in.	16	171G-10215	19	B230+LF24-SR US	14.9	VS-2213-536-9-43	18.7	VG1241DP - 906GA	14.9	VBN2DK3POD	VBN2DK3SOD	
									29.2	VBN2DL3POD	VBN2DL3SOD	
				25	B231+AF24-SR US	36.5	VS-2213-536-9-44			37	VBN2DM3POD	VBN2DM3SOD
				37	B232+AF24-SR US	36.5	VS-2213-536-9-44			41	VBN2DN3POD	VBN2DN3SOD
	40	171G-10216			41.1	VS-2213-536-9-45			41	VBN2DN3POD	VBN2DN3SOD	
	100	171G-10217			102.3	VS-2213-536-9-46			102	VBN2DS3POD	VBN2DS3SOD	
	25	171G-10218	19	B238+AF24-SR US	22.8	VS-2213-536-9-51	18.7	VG1241EP - 906GA	23	VBN2EL3POD	VBN2EL3SOD	
2 in.									29.2	VBN2EM3POD	VBN2EM3SOD	
	40	171G-10220	37	B240+AF24-SR US	41.3	VS-2213-536-9-52	46.8	VG1241ES - 906GA	41	VBN2EN3POD	VBN2EN3SOD	
	63	171G-10219			73.9	VS-2213-536-9-53			74	VBN2ER3POD	VBN2ER3SOD	
	160	171G-10221			171.7	VS-2213-536-9-54			172	VBN2E13POD	VBN2E13SOD	
				29	B248+AF24-SR US				29.2	VG1241FR - 926GGA		
				46	B249+AF24-SR US	41.7	VS-2213-536-9-61	46.8	VG1241FS - 926GGA	42	VBN2FN3POD	VBN2FN3SOD
				57	B250+AF24-SR US				57.0	VBN2FP3POD	VBN2FP3SOD	
2-1/2 in.			65	B251+AF24-MFT US	71.1	VS-2213-536-9-63	73.7	VG1241FT - 926GGA	71	VBN2FR3POD	VBN2FR3SOD	
			85	B252+AF24-MFT US					100.0	VBN2FS3POD	VBN2FS3SOD	
			120	B253+AF24-MFT US	108.0	VS-2213-536-9-65			108.0	VBN2FT3POD	VBN2FT3SOD	
					210.0	VS-2213-536-9-66			210.0	VBN2F13POD	VBN2F13SOD	
				240	B254+AF24-MFT US	266	VS-2213-536-9-67			266.0	VBN2F23POD	VBN2F23SOD
									45.0	VBN2GN3POD	VBN2GN3SOD	
				60	B261+AF24-MFT US	55.0	VS-2213-536-9-72			55.0	VBN2GP3POD	VBN2GP3SOD
3 in.			75	B262+AF24-MFT US	72.3	VS-2213-536-9-73			72	VBN2GR3POD	VBN2GR3SOD	
			110	B263+AF24-MFT US	101.0	VS-2213-536-9-74			101.0	VBN2GS3POD	VBN2GS3SOD	
			150	B264+AF24-MFT US	162.0	VS-2213-536-9-75			162.0	VBN2GU3POD	VBN2GU3SOD	
			210	B265+AF24-MFT US	202.0	VS-2213-536-9-76			202.0	VBN2G13POD	VBN2G13SOD	
									49.0	VBN2HN3POD	VBN2HN3SOD	
				70	B277+AF24-MFT US	63.0	VS-2213-536-9-82			63.0	VBN2HP3POD	VBN2HP3SOD
									82.0	VBN2HR3POD	VBN2HR3SOD	
4 in.			130	B278+AF24-MFT US	124.0	VS-2213-536-9-84			124.0	VBN2HT3POD	VBN2HT3SOD	
			170	B280+AF24-MFT US	145.0	VS-2213-536-9-85			145.0	VBN2HU3POD	VBN2HU3SOD	
									91.0	VBF2J1SOD		
									118.0	VBF2JT1SOD		
									152.0	VBF2JU1SOD		
									197.0	VBF2J11SOD		
									254.0	VBF2J21SOD		
5 in.									144.0	VBF2KU1SOD		
									185.0	VBF2K11SOD		
									240.0	VBF2K21SOD		
									309.0	VBF2K31SOD		
									400	VBF2K41SOD		
									208.0	VBF2L11SOD		
									268.0	VBF2L21SOD		

CROSS REFERENCE

Globe Valve Cross Reference

Threaded Globe Valves

	Pipe Size	Cv	Siemens Model	Cv	Belimo Model	Cv	Invensys	Cv	Johnson Controls	Cv	Honeywell Model
Direct-Acting, Brass Trim 2-Way Valves	1/2"	1	599-03162	0.4	G212	0.4	VB-7213-0-4-01	0.73	VG7241CT	0.73	V5011N1008
		1.6	599-03163	1.3	G213	1.3	VB-7213-0-4-02			1.16	V5011N1016
				2.2	G214	2.2	VB-7213-0-4-03	1.8	VG7241ET	1.85	V5011N1024
		2.5	599-03164							2.9	V5011N1032
		4	599-03165	4.4	G215	4.4	VB-7213-0-4-04	4.6	VG7241GT	4.7	V5011N1040
	3/4"	6.3	599-03166	7.5	G220	7.5	VB-7213-0-4-06	7.3	VG7241LT	7.3	V5011N1057
	1"	10	599-03167	10	G224	10	VB-7213-0-4-07	11.6	VG7241NT	11.7	V5011N1065
	1 1/4"	16	599-03168	20	G232	20	VB-7213-0-4-09	18.5	VG7241PT	18.7	V5011N1073
	1 1/2"	25	599-03169	28	G240	28	VB-7213-0-4-10	28.9	VG7241RT	29.3	V5011N1081
	2"	40	599-03170	40	G250	40	VB-7213-0-4-11	46.2	VG7241ST	46.8	V5011N1099
	2 1/2"					65	VB-9213-0-4-12			63	V5011F1105
3"					85	VB-9213-0-4-13			100	V5011F1113	
Direct-Acting, SS Trim 2-Way Valves	1/2"	1	599-03108					0.73	VG7243CT	0.73	V5011N2006
		1.6	599-03109							1.16	V5011N2014
								1.8	VG7243ET	1.85	V5011N2022
		2.5	599-03110							2.9	V5011N2030
		4	599-03111					4.6	VG7243GT	4.7	V5011N2048
	3/4"	6.3	599-03112					7.3	VG7243LT	7.3	V5011N2055
	1"	10	599-03113					11.6	VG7243NT	11.7	V5011N2063
	1 1/4"	16	599-03114					18.5	VG7243PT	18.7	V5011N2071
	1 1/2"	25	599-03115					28.9	VG7243RT	29.3	V5011N2089
	2"	40	599-03116					46.2	VG7243ST	46.8	V5011N2097
2 1/2"									63	V5011G1111	
3"									100	V5011G1129	
Reverse-Acting 2-Way Valves	1/2"	2.5	599-03182			2.2	VB7223-0-4-03	1.8	VG7441ET	2.9	V5011N3004
		4	599-03183			4.4	VB7223-0-4-04	4.6	VG7441GT	4.7	V5011N3012
	3/4"	6.3	599-03184			7.5	VB7223-0-4-06	7.3	VG7441LT	7.3	V5011N3020
	1"	10	599-03185			10	VB7223-0-4-07	11.6	VG7441NT	11.7	V5011N3038
	1 1/4"	16	599-03186			20	VB7223-0-4-09	18.5	VG7441PT	18.7	V5011N3046
3-Way Valves	1/2"	2.5	599-03200	2.2	G314	1.3	VB-7313-0-4-02	1.8	VG7842ET	2.9	V5013N1030
		4	599-03201	4.4	G315	4.4	VB-7313-0-4-04	4.6	VG7842GT	4.7	V5013N1048
	3/4"	6.3	599-03202	7.5	G320	7.5	VB-7313-0-4-06	7.3	VG7842LT	7.3	V5013N1055
	1"	10	599-03203	14	G325	14	VB-7313-0-4-08	11.6	VG7842NT	11.7	V5013N1063
	1 1/4"	16	599-03204	20	G332	20	VB-7313-0-4-09	18.5	VG7842PT	18.7	V5013N1071
	1 1/2"	25	599-03205	28	G340	28	VB-7313-0-4-10	28.9	VG7842RT	29.3	V5013N1089
	2"	40	599-03206	41	G350	40	VB-7313-0-4-11	46.2	VG7842ST	46.8	V5013N1097

Globe Valve Cross Reference

Flanged Globe Valves

	Pipe Size	Cv	Johnson Controls	Cv	Belimo Model	Cv	Invensys	Cv	Honeywell Model
Bronze Trim, ANSI 125 2-Way Valves	2 1/2"	51	VB-3752-19	65	G665	56	VB-9213-0-5-12	63	V3351A2008
	3"	83	VB-3752-22	90	G680	85	VB-9213-0-5-13	100	V3351A3006
	4"	150	VB-3752-25	170	G6100	145	VB-9213-0-5-14	160	V3351A4004
	5"	240	VB-3752-28	263	G6125	235	VB-9213-0-5-15	250	V3351A5001
	6"	350	VB-3752-31	344	G6150	350	VB-9213-0-5-16	400	V3351A6009
	2 1/2"	51	VB-3970-11			56	VB-9223-0-5-12	63	V3351C2004
	3"	83	VB-3970-14			85	VB-9223-0-5-13	100	V3351C3002
	4"	150	VB-3970-17			145	VB-9223-0-5-14	160	V3351C4000
	5"	240	VB-3970-20			235	VB-9223-0-5-15	250	V3351C5007
	6"	350	VB-3970-23			350	VB-9223-0-5-16	400	V3351C6005
Mixing, ANSI 125 3-Way Valves	2 1/2"	54	VB-4322-9	68	G765	56	VB-9313-0-5-12	63	V3360E2008
	3"	80	VB-4322-11	91	G780	85	VB-9313-0-5-13	100	V3360E3006
	4"	157	VB-4322-13	190	G7100	145	VB-9313-0-5-14	160	V3360E4004
	5"	238	VB-4322-19	280	G7125	235	VB-9313-0-5-15	250	V3360E5001
	6"	347	VB-4322-18	340	G7150	350	VB-9313-0-5-16	400	V3360E6009
Diverting, ANSI 125 3-Way Valves	2 1/2"			38	G765D	56	VB-9323-0-5-12	63	V5013C1001
	3"			85	G780D	85	VB-9323-0-5-13	100	V5013C1019
	4"			154	G7100D	145	VB-9323-0-5-14	160	V5013C1027
	5"			195	G7125D	235	VB-9323-0-5-15	250	V5013C1035
	6"			248	G7150D	350	VB-9323-0-5-16	360	V5013C1043

Pneumatics Cross Reference

ITEM NUMBER	MANUFACTURER	REPLACEMENT ITEM	TYPE OF REPLACEMENT	REMARKS
2463-863	ROBERTSHAW	MP516A1087	FUNCTIONAL	
2464-861	ROBERTSHAW	MP516A1087	FUNCTIONAL	
2466-011	ROBERTSHAW	MP920B1002 with 14004345-001	FUNCTIONAL	
2466-051	ROBERTSHAW	MP920B1002	FUNCTIONAL	
2472-020	ROBERTSHAW	MP909D1201	FUNCTIONAL	
2472-030	ROBERTSHAW	MP909D1227	FUNCTIONAL	
2472-040	ROBERTSHAW	MP909D1219	FUNCTIONAL	
2472-050	ROBERTSHAW	MP909A1660	FUNCTIONAL	
2472-110	ROBERTSHAW	MP909A1041	FUNCTIONAL	
2472-120	ROBERTSHAW	MP909D1201	FUNCTIONAL	
2472-140	ROBERTSHAW	MP909D1219	FUNCTIONAL	
2473-010	ROBERTSHAW	MP909E1018	FUNCTIONAL	
2473-020	ROBERTSHAW	MP909E1083	FUNCTIONAL	
2473-030	ROBERTSHAW	MP909E1034	FUNCTIONAL	
2473-110	ROBERTSHAW	MP909E1018	FUNCTIONAL	
2473-120	ROBERTSHAW	MP909E1083	FUNCTIONAL	
2473-140	ROBERTSHAW	MP909E1174	FUNCTIONAL	
2474-160	ROBERTSHAW	MP909H1331 or MP918A1024	FUNCTIONAL	
2566-002	ROBERTSHAW	V5013F1004 with MP953C1000	FUNCTIONAL	
2566-004	ROBERTSHAW	V5013F1004 with MP953C1018	FUNCTIONAL	
2566-006	ROBERTSHAW	V5013F1004 with MP953E1319	FUNCTIONAL	
2566-008	ROBERTSHAW	V5013F1020 with MP953C1000	FUNCTIONAL	
2566-010	ROBERTSHAW	V5013F1020 with MP953C1018	FUNCTIONAL	
2566-012	ROBERTSHAW	V5013F1020 with MP953E1319	FUNCTIONAL	
2566-014	ROBERTSHAW	V5013F1038 with MP953C1000	FUNCTIONAL	
2566-016	ROBERTSHAW	V5013F1038 with MP953C1018	FUNCTIONAL	
2566-018	ROBERTSHAW	V5013F1038 with MP953E1319	FUNCTIONAL	
2566-020	ROBERTSHAW	V5013F1046 with MP953C1000	FUNCTIONAL	
2566-022	ROBERTSHAW	V5013F1046 with MP953C1018	FUNCTIONAL	
2566-023	ROBERTSHAW	V5013F1046 with MP953E1319	FUNCTIONAL	
2566-025	ROBERTSHAW	V5013F1053 with MP953C1000	FUNCTIONAL	
2566-027	ROBERTSHAW	V5013F1053 with MP953C1018	FUNCTIONAL	
2566-028	ROBERTSHAW	V5013F1053 with MP953E1319	FUNCTIONAL	
2566-030	ROBERTSHAW	V5013F1061 with MP953C1000	FUNCTIONAL	
2566-032	ROBERTSHAW	V5013F1061 with MP953C1018	FUNCTIONAL	
2566-033	ROBERTSHAW	V5013F1061 with MP953E1319	FUNCTIONAL	
2566-102	ROBERTSHAW	V5013F1004 with MP958C1000	FUNCTIONAL	
2566-104	ROBERTSHAW	V5013F1004 with MP953C1018	FUNCTIONAL	
2566-106	ROBERTSHAW	V5013F1004 with MP953E1319	FUNCTIONAL	
2566-108	ROBERTSHAW	V5013F1004 with MP953C1000	FUNCTIONAL	
2566-110	ROBERTSHAW	V5013F1004 with MP953C1018	FUNCTIONAL	
2566-112	ROBERTSHAW	V5013F1004 with MP953E1319	FUNCTIONAL	
2567-001	ROBERTSHAW	V5011F1006 with MP953D1172	FUNCTIONAL	
2567-003	ROBERTSHAW	V5011F1006 with MP953D1107	FUNCTIONAL	
2567-004	ROBERTSHAW	V5011F1006 with MP953F1119	FUNCTIONAL	
2567-005	ROBERTSHAW	V5011F1022 with MP953D1172	FUNCTIONAL	
2567-007	ROBERTSHAW	V5011F1022 with MP953D1107	FUNCTIONAL	
2567-008	ROBERTSHAW	V5011F1022 with MP953F1119	FUNCTIONAL	

ITEM NUMBER	MANUFACTURER	REPLACEMENT ITEM	TYPE OF REPLACEMENT	REMARKS
2567-009	ROBERTSHAW	V5011H1022 with MP953C1000	FUNCTIONAL	
2567-011	ROBERTSHAW	V5011H1022 with MP953C1018	FUNCTIONAL	
2567-012	ROBERTSHAW	V5011H1022 with MP953E1327	FUNCTIONAL	
2567-013	ROBERTSHAW	V5011H1022 with MP953C1000	FUNCTIONAL	
2567-015	ROBERTSHAW	V5011H1022 with MP953C1018	FUNCTIONAL	
2567-016	ROBERTSHAW	V5011H1022 with MP953E1327	FUNCTIONAL	
2567-017	ROBERTSHAW	V5011H1028 with MP953C1000	FUNCTIONAL	
2567-019	ROBERTSHAW	V5011H1028 with MP953C1018	FUNCTIONAL	
2567-020	ROBERTSHAW	V5011H1028 with MP953E1327	FUNCTIONAL	
2567-021	ROBERTSHAW	V5011H1036 with MP953C1000	FUNCTIONAL	
2567-023	ROBERTSHAW	V5011H1036 with MP953C1018	FUNCTIONAL	
2567-024	ROBERTSHAW	V5011H1036 with MP953E1327	FUNCTIONAL	
2567-025	ROBERTSHAW	V5011H1044 with MP953C1000	FUNCTIONAL	
2567-027	ROBERTSHAW	V5011H1044 with MP953C1018	FUNCTIONAL	
2567-028	ROBERTSHAW	V5011H1044 with MP953E1327	FUNCTIONAL	
2567-029	ROBERTSHAW	V5011H1089 with MP953D1172	FUNCTIONAL	
2567-031	ROBERTSHAW	V5011H1089 with MP953D1107	FUNCTIONAL	
2567-032	ROBERTSHAW	V5011H1089 with MP953F1119	FUNCTIONAL	
2567-033	ROBERTSHAW	V5011H1097 with MP953D1172	FUNCTIONAL	
2567-035	ROBERTSHAW	V5011H1097 with MP953D1107	FUNCTIONAL	
2567-036	ROBERTSHAW	V5011H1097 with MP953F1119	FUNCTIONAL	
2568-003	ROBERTSHAW	V5011F1014 with MP953C1018	FUNCTIONAL	
2568-004	ROBERTSHAW	V5011F1014 with MP953C1000	FUNCTIONAL	
2568-005	ROBERTSHAW	V5011F1014 with MP953E1327	FUNCTIONAL	
2568-008	ROBERTSHAW	V5011F1022 with MP953C1018	FUNCTIONAL	
2568-009	ROBERTSHAW	V5011F1022 with MP953C1000	FUNCTIONAL	
2568-010	ROBERTSHAW	V5011F1022 with MP953E1327	FUNCTIONAL	
2568-013	ROBERTSHAW	V5011F1030 with MP953C1018	FUNCTIONAL	
2568-014	ROBERTSHAW	V5011F1030 with MP953C1000	FUNCTIONAL	
2568-015	ROBERTSHAW	V5011F1030 with MP953E1327	FUNCTIONAL	
2568-018	ROBERTSHAW	V5011F1055 with MP953C1018	FUNCTIONAL	
2568-019	ROBERTSHAW	V5011F1055 with MP953C1000	FUNCTIONAL	3 psi positioner span
2568-020	ROBERTSHAW	V5011F1055 with MP953E1327	FUNCTIONAL	External Only, 3 psi positioner span
2568-023	ROBERTSHAW	V5011F1063 with MP953C1018	FUNCTIONAL	External Only, 5 psi positioner span
2568-024	ROBERTSHAW	V5011F1063 with MP953C1000	FUNCTIONAL	
2568-025	ROBERTSHAW	V5011F1063 with MP953E1327	FUNCTIONAL	
2568-028	ROBERTSHAW	V5011F1071 with MP953C1018	FUNCTIONAL	
2568-029	ROBERTSHAW	V5011F1071 with MP953C1000	FUNCTIONAL	
2568-030	ROBERTSHAW	V5011F1071 with MP953E1327	FUNCTIONAL	External Only, 10 psi positioner span
2568-033	ROBERTSHAW	V5011F1089 with MP953C1018	FUNCTIONAL	

Pneumatics Cross Reference

ITEM NUMBER	MANUFACTURER	REPLACEMENT ITEM	TYPE OF REPLACEMENT	REMARKS
2568-034	ROBERTSHAW	V5011F1089 with MP953C1000	FUNCTIONAL	
2568-035	ROBERTSHAW	V5011F1089 with MP953E1327	FUNCTIONAL	
2568-038	ROBERTSHAW	V5011F1097 with MP953C1018	FUNCTIONAL	Internal normally close only, 3 psi positioner span
2568-039	ROBERTSHAW	V5011F1097 with MP953C1000	FUNCTIONAL	Internal normally close only, 5 psi positioner span
2568-040	ROBERTSHAW	V5011F1097 with MP953E1327	FUNCTIONAL	Internal normally close only, 10 psi positioner span
657-8225	POWERS/LANDIS & GYR	V5013F1020 with MP953C1018	FUNCTIONAL	
658-0026	POWERS/LANDIS & GYR	V5013F1004 with MP953C1000	FUNCTIONAL	5 psi positioner span
658-0028	POWERS/LANDIS & GYR	V5013F1020 with MP953C1000	FUNCTIONAL	10 psi positioner span
D101	JOHNSON CONTROLS	MP909D1201 or MP909D1219 or MP909D1227	FUNCTIONAL	
D103	JOHNSON CONTROLS	MP909E1083 or MP909E1174	FUNCTIONAL	
D251	JOHNSON CONTROLS	MP909D1201 or MP909D1219 or MP909D1227	FUNCTIONAL	External Only
D251(4)	JOHNSON CONTROLS	MP918B1030 or MP918B1113 or MP918B1139 or MP918B1147	FUNCTIONAL	
D251(6)	JOHNSON CONTROLS	MP920B1002	FUNCTIONAL	External Only
D3031-3	JOHNSON CONTROLS	MP913A1052	FUNCTIONAL	Internal normally closed only
D3070-1	JOHNSON CONTROLS	MP516A1087	FUNCTIONAL	
D3073-2	JOHNSON CONTROLS	MP909E1174	FUNCTIONAL	Internal normally closed only
D3073-3	JOHNSON CONTROLS	MP909E1034	FUNCTIONAL	
D3073-7	JOHNSON CONTROLS	MP909E1083	FUNCTIONAL	
D3153-2	JOHNSON CONTROLS	MP918B1089	FUNCTIONAL	
D3153-3	JOHNSON CONTROLS	MP918B1048	FUNCTIONAL	
M556-14	ROBERTSHAW	MP920B1002 with 14004345-001	FUNCTIONAL	
M556-51	ROBERTSHAW	MP920B1002	FUNCTIONAL	
M572-2311	ROBERTSHAW	MP909A1041	FUNCTIONAL	
M572-3308	ROBERTSHAW	MP909D1227	FUNCTIONAL	
M572-5311	ROBERTSHAW	MP909D1219	FUNCTIONAL	
M572-6308	ROBERTSHAW	MP913A1660	FUNCTIONAL	
M572-8311	ROBERTSHAW	MP909D1201	FUNCTIONAL	
M573-2108	ROBERTSHAW	MP909E1018	FUNCTIONAL	
M573-2111	ROBERTSHAW	MP909E1018	FUNCTIONAL	
M573-3108	ROBERTSHAW	MP909E1034	FUNCTIONAL	
M573-5111	ROBERTSHAW	MP909E1174	FUNCTIONAL	External Only
M573-8111	ROBERTSHAW	MP909E1083	FUNCTIONAL	For unitary applications, consult technical support.
M574-1211	ROBERTSHAW	MP909H1331 or MP918A1024	FUNCTIONAL	External Only
M583-0520	ROBERTSHAW	MP516A1087	FUNCTIONAL	For unitary applications, consult technical support.
M584	ROBERTSHAW	MP516A1087	FUNCTIONAL	
MK3101	BARBER COLMAN	MP909E1083 or MP918B1063	FUNCTIONAL	
MK3111	BARBER COLMAN	MP909E1034 or MP918B1048	FUNCTIONAL	Internal normally closed only
MK3121	BARBER COLMAN	MP909E1174 or MP918B1097	FUNCTIONAL	Internal normally closed only
MK3141	BARBER COLMAN	MP909E1018 or MP918B1006	FUNCTIONAL	
MK3201	BARBER COLMAN	MP909E1083 or MP918B1063	FUNCTIONAL	

ITEM NUMBER	MANUFACTURER	REPLACEMENT ITEM	TYPE OF REPLACEMENT	REMARKS
MK3211	BARBER COLMAN	MP909E1034 or MP918B1048	FUNCTIONAL	External Only
MK3221	BARBER COLMAN	MP909E1174 or MP918B1063	FUNCTIONAL	External Only
MK4-3101	BARBER COLMAN	MP909H1331	FUNCTIONAL	For unitary applications, consult technical support.
MK4-3111	BARBER COLMAN	MP909H1331	FUNCTIONAL	
MK4-3121	BARBER COLMAN	MP909H1331	FUNCTIONAL	Internal normally closed only
MK4-3141	BARBER COLMAN	MP909H1331	FUNCTIONAL	Internal normally closed only
MK4-3801	BARBER COLMAN	MP909H1331	FUNCTIONAL	
MK4-3811	BARBER COLMAN	MP909H1331	FUNCTIONAL	
MK4-3821	BARBER COLMAN	MP909H1331	FUNCTIONAL	For unitary applications, consult technical support.
MK4-3841	BARBER COLMAN	MP909H1331	FUNCTIONAL	
MK4401	BARBER COLMAN	MP516A1095	FUNCTIONAL	
MK4411	BARBER COLMAN	MP516A1103	FUNCTIONAL	
MK4421	BARBER COLMAN	MP909E1158	FUNCTIONAL	
MK4451	BARBER COLMAN	MP516A1087	FUNCTIONAL	
MK4461	BARBER COLMAN	MP516A1087	FUNCTIONAL	
MK4-7101	BARBER COLMAN	MP918A1024	FUNCTIONAL	
MK4-7121	BARBER COLMAN	MP918A1024	FUNCTIONAL	
MK7101	BARBER COLMAN	MP918B1063	FUNCTIONAL	
MK7121	BARBER COLMAN	MP918B1089	FUNCTIONAL	
MP904A1145	HONEYWELL	MP918A1008	FUNCTIONAL	External Only, 3 psi positioner span
MP904A1145	HONEYWELL	MP918A1016	FUNCTIONAL	External Only, 5 psi positioner span
MP904A1145	HONEYWELL	MP918A1024	FUNCTIONAL	External Only, 10 psi positioner span
MP904A1145	HONEYWELL	MP918A1032	FUNCTIONAL	Internal normally close only, 3 psi positioner span
MP904A1145	HONEYWELL	MP918A1040	FUNCTIONAL	Internal normally close only, 5 psi positioner span
MP904A1145	HONEYWELL	MP918A1057	FUNCTIONAL	Internal normally close only, 10 psi positioner span
MP904A1152	HONEYWELL	MP917A1065	FUNCTIONAL	3 psi positioner span
MP904A1152	HONEYWELL	MP918A1073	FUNCTIONAL	5 psi positioner span
MP904A1152	HONEYWELL	MP918A1081	FUNCTIONAL	10 psi positioner span
MP904A1186	HONEYWELL	MP918A1099	FUNCTIONAL	
MP904B1028	HONEYWELL	MP918B1006	FUNCTIONAL	External Only
MP904B1028	HONEYWELL	MP918B1014	FUNCTIONAL	Internal normally closed only
MP904B1093	HONEYWELL	MP918B1063	FUNCTIONAL	External Only
MP904B1093	HONEYWELL	MP918B1071	FUNCTIONAL	Internal normally closed only
MP904B1101	HONEYWELL	MP918B1097	FUNCTIONAL	Internal normally closed only
MP904B1101	HONEYWELL	MP918B1089	FUNCTIONAL	External Only
MP904B1119	HONEYWELL	MP918B1014	FUNCTIONAL	
MP904B1127	HONEYWELL	MP918B1022	FUNCTIONAL	
MP904B1135	HONEYWELL	MP918B1105	FUNCTIONAL	
MP904B1150	HONEYWELL	MP918B1030	FUNCTIONAL	
MP904C1026	HONEYWELL	MP918A1024	FUNCTIONAL	
MP904C1328	HONEYWELL	MP918B1006	FUNCTIONAL	
MP904C1377	HONEYWELL	MP918B1030	FUNCTIONAL	
MP909A1041	MIRCOSWITCH	MP909D1227 with 14002850-001 with 312867H	FUNCTIONAL	
MP909A1132	HONEYWELL	MP909A1652	FUNCTIONAL	
MP909A1637	MIRCOSWITCH	MP909D1227 with 14002850-001 with 312867H	FUNCTIONAL	

CROSS REFERENCE

Pneumatics Cross Reference

ITEM NUMBER	MANUFACTURER	REPLACEMENT ITEM	TYPE OF REPLACEMENT	REMARKS
MP909A1645	HONEYWELL	MP909D1227 with 14002850-001 with 312867H with 14002061-001	FUNCTIONAL	
MP909A1652	MIRCOSWITCH	MP909D1201 with 14002850-001 with 312867H	FUNCTIONAL	
MP909A1660	MIRCOSWITCH	MP909D1219 with 14002850-001 with 312867H	FUNCTIONAL	
MP909A1744		MP909E1232	FUNCTIONAL	
MP909C1021	HONEYWELL	MP918B1063	FUNCTIONAL	For unitary applications, consult technical support.
MP909C1047	HONEYWELL	MP918B1048	FUNCTIONAL	
MP909C1054	HONEYWELL	MP918B1006	FUNCTIONAL	External Only
MP909C1054	HONEYWELL	MP918B1014	FUNCTIONAL	Internal normally closed only
MP909C1161	HONEYWELL	MP918B1063	FUNCTIONAL	External Only
MP909C1161	HONEYWELL	MP918B1071	FUNCTIONAL	Internal normally closed only
MP909C1179	HONEYWELL	MP918B1097	FUNCTIONAL	Internal normally closed only
MP909C1179	HONEYWELL	MP918B1089	FUNCTIONAL	External Only
MP909C1187	HONEYWELL	MP918B1113	FUNCTIONAL	For unitary applications, consult technical support.
MP909C1286	HONEYWELL	MP918B1048	FUNCTIONAL	
MP909C1294	HONEYWELL	MP918B1022	FUNCTIONAL	
MP909C1310	HONEYWELL	MP918B1063	FUNCTIONAL	For unitary applications, consult technical support.
MP909C1336	HONEYWELL	MP918B1063	FUNCTIONAL	
MP909C1344	HONEYWELL	MP918B1089	FUNCTIONAL	For unitary applications, consult technical support.
MP909D1268	MIRCOSWITCH	MP909D1201 with 14003640-001	DIRECT	
MP909D1292	MIRCOSWITCH	MP909D1227 with 315439/00062	FUNCTIONAL	
MP909D1300	HONEYWELL	MP909D1201	FUNCTIONAL	
MP909D1359	MIRCOSWITCH	MP909D1201 with 14003640-001 with 315781	FUNCTIONAL	
MP909E1265	HONEYWELL	MP909E1232	FUNCTIONAL	
MP909E1497	MIRCOSWITCH	MP909D1201 with 14003640-001 with 315781	FUNCTIONAL	
MP909E1505	HONEYWELL	MP909E1034	FUNCTIONAL	
MP909H1459	HONEYWELL	MP909H1392	FUNCTIONAL	
MP913A1045	HONEYWELL	MP913A1037	FUNCTIONAL	
MP918A1115	HONEYWELL	MP918A1024	FUNCTIONAL	
MP918A1123	HONEYWELL	MP918A1057	FUNCTIONAL	
MP918A115	HONEYWELL	MP918A1024	FUNCTIONAL	
MP918B1220	HONEYWELL	MP918B1063	FUNCTIONAL	
MP920A1004	HONEYWELL	MP920B1002 with 14004345-001	DIRECT	
MP953D1222	HONEYWELL	MP953D1131	FUNCTIONAL	
MP953D1255	HONEYWELL	MP953D1172	FUNCTIONAL	
MP953E1392	MIRCOSWITCH	MP953E1400 with 14004212-001	DIRECT	
PM331	POWERS/LANDIS & GYR	MP920B1002	FUNCTIONAL	
PM331-4X3H	POWERS/LANDIS & GYR	MP516A1087	FUNCTIONAL	
PM331LC	POWERS/LANDIS & GYR	MP920B1002 with 14004345-001	FUNCTIONAL	
2567-016	ROBERTSHAW	MP953E1327	FUNCTIONAL	
2567-020	ROBERTSHAW	MP953E1327	FUNCTIONAL	

ITEM NUMBER	MANUFACTURER	REPLACEMENT ITEM	TYPE OF REPLACEMENT	REMARKS
2567-024	ROBERTSHAW	MP953E1327	FUNCTIONAL	
2567-028	ROBERTSHAW	MP953E1327	FUNCTIONAL	
2568-005	ROBERTSHAW	MP953E1327	FUNCTIONAL	
2568-010	ROBERTSHAW	MP953E1327	FUNCTIONAL	
2568-015	ROBERTSHAW	MP953E1327	FUNCTIONAL	
2568-020	ROBERTSHAW	MP953E1327	FUNCTIONAL	
2568-025	ROBERTSHAW	MP953E1327	FUNCTIONAL	
2568-030	ROBERTSHAW	MP953E1327	FUNCTIONAL	
2568-035	ROBERTSHAW	MP953E1327	FUNCTIONAL	
2568-040	ROBERTSHAW	MP953E1327	FUNCTIONAL	
MP953E1392	MIRCOSWITCH	MP953E1400	DIRECT	
2567-004	ROBERTSHAW	MP953F1119	FUNCTIONAL	
2567-008	ROBERTSHAW	MP953F1119	FUNCTIONAL	
2567-032	ROBERTSHAW	MP953F1119	FUNCTIONAL	
2567-036	ROBERTSHAW	MP953F1119	FUNCTIONAL	
2566-102	ROBERTSHAW	MP958C1000	FUNCTIONAL	

Modutrol IV Motor Cross Reference

ITEM NUMBER	REPL TYPE	REPL ITEM	MULTI REPL	REPL SEQ	CHANNEL (BUSI GROUP)	MFG NAME	CUSTOMER REMARKS
2005377	FUNCTIONAL	M934A1334/U		1	TRADE	SINGER CO	
612804451	FUNCTIONAL	M945D1006/U		1	TRADE	HARTZELL PROP	
203762E/U	FUNCTIONAL	M8185D1006/U	WITH	1	TRADE		
2061-1	FUNCTIONAL	M835A1051/U		1	TRADE	WHITE RODGERS	
3402-7	FUNCTIONAL	M8415A1004/U		1	TRADE	WHITE RODGERS	
3402A-7	FUNCTIONAL	M8415A1004/U		1	TRADE	WHITE RODGERS	
3403-4	FUNCTIONAL	M8405A1006/U		1	TRADE	WHITE RODGERS	
3405-11	FUNCTIONAL	M836A1042/U		1	TRADE	WHITE RODGERS	
3405-14	FUNCTIONAL	M836A1042/U		1	TRADE	WHITE RODGERS	
3405-15	FUNCTIONAL	M836B1033/U		1	TRADE	WHITE RODGERS	
3405-2	FUNCTIONAL	M836A1042/U		1	TRADE	WHITE RODGERS	
3405-3	FUNCTIONAL	M836A1042/U		1	TRADE	WHITE RODGERS	
3405A-11	FUNCTIONAL	M436A1116/U		1	TRADE	WHITE RODGERS	
3405A-2	FUNCTIONAL	M436A1116/U		1	TRADE	WHITE RODGERS	
3420-4	FUNCTIONAL	M9175D1014/U		1	TRADE	WHITE RODGERS	
3420A-4	FUNCTIONAL	M9175D1014/U	WITH	1	TRADE	WHITE RODGERS	
3430-18	DIRECT	M7975E1009/U		1	TRADE	WHITE RODGERS	
3430-21	DIRECT	M7975E1009/U		1	TRADE	WHITE RODGERS	
3430-7	FUNCTIONAL	M7415A1006/U		1	TRADE	WHITE RODGERS	
3440-4	FUNCTIONAL	M9184D1013/U	OR	1	TRADE	WHITE RODGERS	
3440-4	FUNCTIONAL	M9184A1019/U		2	TRADE	WHITE RODGERS	
430-2625	FUNCTIONAL	M934A1326/U		1	TRADE	ITT GENERAL CONTROLS	
430-2630	FUNCTIONAL	M934A1334/U		1	TRADE	ITT GENERAL CONTROLS	
474-4-7914	FUNCTIONAL	M934A1318/U		1	TRADE	ITT GENERAL CONTROLS	
4EQZ-3898	FUNCTIONAL	M945D1006/U		1	TRADE	AM AIR FILTER	
4EZB3762A	FUNCTIONAL	M945H 1002		1	TRADE	AM AIR FILTER	
4EZB-3762A	FUNCTIONAL	M945H 1002		1	TRADE	AM AIR FILTER	
4EZB-3919A	FUNCTIONAL	M945D1006/U		1	TRADE	AM AIR FILTER	
4EZB-4109	FUNCTIONAL	M945D1006/U		1	TRADE	AM AIR FILTER	
8414-00	FUNCTIONAL	M644C1006/U		1	TRADE	MID-CONT METL	
894-1072	FUNCTIONAL	M644E 1004		1	TRADE	IND COMBUSTION	
AE107	FUNCTIONAL	M945D1006/U		1	TRADE	AM AIR FILTER	
AV8050-1008	FUNCTIONAL	M6410A1003/U	OR	2	TRADE	JOHNSON CONTROLS	
AV8050-1008	FUNCTIONAL	M6410A1011/U		3	TRADE	JOHNSON CONTROLS	
AV8050-1009	FUNCTIONAL	M6410A1003/U	OR	2	TRADE	JOHNSON CONTROLS	
AV8050-1009	FUNCTIONAL	M6410A1011/U		3	TRADE	JOHNSON CONTROLS	
D55759-1	FUNCTIONAL	M745A1003/U		1	TRADE	AMANA	
DM4BB00000000	FUNCTIONAL	M944A1010/U	OR	1	TRADE	ITT GENERAL CONTROLS	
DM4BB00000000	FUNCTIONAL	M934A1342/U		2	TRADE	ITT GENERAL CONTROLS	
HF25AA001	FUNCTIONAL	M944B1191/U		1	TRADE	CARRIER	
IR-410-2341	FUNCTIONAL	M954A1035/U		1	TRADE	NORTH AM MFG	
IR-410-2351	FUNCTIONAL	M644B1049/U		1	TRADE	NORTH AM MFG	
M110AAB-1	FUNCTIONAL	M8185D1006/U	WITH	1	TRADE	JOHNSON CONTROLS	
M110AGA-1	FUNCTIONAL	M8185D1006/U	OR	1	TRADE	JOHNSON CONTROLS	
M110AGA-1	FUNCTIONAL	M8175B1002/U		2	TRADE	JOHNSON CONTROLS	
M110AGB-1	FUNCTIONAL	M8185D1006/U	WITH	1	TRADE	JOHNSON CONTROLS	
M110AGB-1	FUNCTIONAL	M8175B1002/U		3	TRADE	JOHNSON CONTROLS	
M110GGA-1	FUNCTIONAL	M9175D1014/U	WITH	1	TRADE	JOHNSON CONTROLS	
M110JGA-1	FUNCTIONAL	M9175D1014/U		1	TRADE	JOHNSON CONTROLS	
M110JGB-1	FUNCTIONAL	M9175D1014/U	WITH	1	TRADE	JOHNSON CONTROLS	
M120AAA-1	FUNCTIONAL	M6184D1035/U	WITH	1	TRADE	JOHNSON CONTROLS	
M120AAC-1	FUNCTIONAL	M6184D1035/U	WITH	1	TRADE	JOHNSON CONTROLS	
M120AGA-1	FUNCTIONAL	M6184D1035/U	OR	1	TRADE	JOHNSON CONTROLS	
M120AGA-1	FUNCTIONAL	M6184F1006/U		2	TRADE	JOHNSON CONTROLS	
M120GGA-1	FUNCTIONAL	M9164D1009/U	WITH	1	TRADE	JOHNSON CONTROLS	
M120JAA-1	FUNCTIONAL	M9164D1009/U	WITH	1	TRADE	JOHNSON CONTROLS	
M120JAC-1	FUNCTIONAL	M9164D1009/U	WITH	1	TRADE	JOHNSON CONTROLS	
M120JAC-1	FUNCTIONAL	M9164C1019/U		3	TRADE	JOHNSON CONTROLS	
M120JGA-1	FUNCTIONAL	M9164D1009/U	OR	1	TRADE	JOHNSON CONTROLS	
M120JGA-1	FUNCTIONAL	M9164A1021		2	TRADE	JOHNSON CONTROLS	
M130AAB-1	FUNCTIONAL	M8185D1006/U	WITH	1	TRADE	JOHNSON CONTROLS	
M130AAB-1	FUNCTIONAL	M4185B1017/U		4	TRADE	JOHNSON CONTROLS	
M130AGA-1	FUNCTIONAL	M8185D1006/U	OR	1	TRADE	JOHNSON CONTROLS	
M130AGA-1	FUNCTIONAL	M8185B1000/U		2	TRADE	JOHNSON CONTROLS	
M130AGB-1	FUNCTIONAL	M8185D1006/U	WITH	1	TRADE	JOHNSON CONTROLS	
M130AGB-1	FUNCTIONAL	M8185B1000/U		3	TRADE	JOHNSON CONTROLS	
M130GGA-1	FUNCTIONAL	M9185D1004/U	WITH	1	TRADE	JOHNSON CONTROLS	
M130JGA-1	FUNCTIONAL	M9185D1004/U	OR	1	TRADE	JOHNSON CONTROLS	
M130JGA-1	FUNCTIONAL	M9185A1018/U		2	TRADE	JOHNSON CONTROLS	
M130JGB-1	FUNCTIONAL	M9185D1004/U	WITH	1	TRADE	JOHNSON CONTROLS	
M130JGB-1	FUNCTIONAL	M9185E1019		3	TRADE	JOHNSON CONTROLS	
M140AAA-1	FUNCTIONAL	M6184D1035/U		1	TRADE	JOHNSON CONTROLS	
M140AGA-1	FUNCTIONAL	M6184D1035/U		1	TRADE	JOHNSON CONTROLS	

CROSS REFERENCE

Modutrol IV Motor Cross Reference

ITEM NUMBER	REPL TYPE	REPL ITEM	MULTI REPL	REPL SEQ	CHANNEL (BUSI GROUP)	MFG NAME	CUSTOMER REMARKS
M140GGA-1	FUNCTIONAL	M9174D1007/U	WITH	1	TRADE	JOHNSON CONTROLS	
M140JAA-1	FUNCTIONAL	M9174D1007/U	WITH	1	TRADE	JOHNSON CONTROLS	
M140JGA-1	FUNCTIONAL	M9174D1007/U		1	TRADE	JOHNSON CONTROLS	
M150AGA-1	FUNCTIONAL	M6184D1035/U		1	TRADE	JOHNSON CONTROLS	
M150AGB-1	FUNCTIONAL	M6184D1035/U	WITH	1	TRADE	JOHNSON CONTROLS	
M150AGB-1	FUNCTIONAL	M6184F1017/u		3	TRADE	JOHNSON CONTROLS	
M150GGA-1	FUNCTIONAL	M9184D1013/U	WITH	1	TRADE	JOHNSON CONTROLS	
M150GGA-1	FUNCTIONAL	M7284Q1017/U		3	TRADE	JOHNSON CONTROLS	
M150JGA-1	FUNCTIONAL	M9184D1021/u	OR	1	TRADE	JOHNSON CONTROLS	
M150JGA-1	FUNCTIONAL	M9184A1019/U		2	TRADE	JOHNSON CONTROLS	
M150JGB-1	FUNCTIONAL	M9184D1021/U	WITH	1	TRADE	JOHNSON CONTROLS	
M150JGB-1	FUNCTIONAL	M9184F1034/U		3	TRADE	JOHNSON CONTROLS	
M150JGC-1	FUNCTIONAL	M9184D1021/U	WITH	1	TRADE	JOHNSON CONTROLS	
M150JGC-1	FUNCTIONAL	M9184F1034/U		3	TRADE	JOHNSON CONTROLS	
M150QGA-1	FUNCTIONAL	M7284Q1017/u		0	ALL	JOHNSON CONTROLS	
M40AAA-1	FUNCTIONAL	M9164D1009/U	WITH	1	TRADE	JOHNSON CONTROLS	
M40AAA-1	FUNCTIONAL	M9164A1005/U		3	TRADE	JOHNSON CONTROLS	
M40AAC-1	FUNCTIONAL	M9164D1009/U	WITH	1	TRADE	JOHNSON CONTROLS	
M40AAC-1	FUNCTIONAL	M9164C1068/U		4	TRADE	JOHNSON CONTROLS	
M40AGA-1	FUNCTIONAL	M6184D1035/U	OR	1	TRADE	JOHNSON CONTROLS	
M40AGA-1	FUNCTIONAL	M6184A1015/U		2	TRADE	JOHNSON CONTROLS	
M40AGC-1	FUNCTIONAL	M9164D1009/U	WITH	1	TRADE	JOHNSON CONTROLS	
M410GGA-1	FUNCTIONAL	M9174D1007/U	WITH	1	TRADE	JOHNSON CONTROLS	
M4175D1015/U	DIRECT	M4185B1058/U		1	ALL		
M4175E1012/U	FUNCTIONAL	M8185D1006/U	WITH	1	ALL	HONEYWELL	
M4182A1004/P	DIRECT	M4185A1001/U		1	ALL		
M4182A1004/U	DIRECT	M4185A1001/U	WITH	1	ALL		
M4182A1004/U	FUNCTIONAL	M4185A1001/U			ALL		
M4182B1002/P	DIRECT	M4185B1009/U	WITH	1	ALL		
M4182B1002/U	DIRECT	M4185B1009/U	WITH	1	ALL		
M4182B1010/U	DIRECT	M8185D1006/U	WITH	1	ALL	HONEYWELL	
M4182B1028/U	FUNCTIONAL	M8185D1006/U	WITH	1	ALL	HONEYWELL	
M4182B1036/P	DIRECT	M4185B1009/U	WITH	1	ALL		
M4182B1036/U	DIRECT	M4185B1009/U	WITH	1	ALL		
M4182B1036/U	FUNCTIONAL	M4185B1058/U			ALL		
M4182B1044/U	DIRECT	M4185B1058/U	WITH	1	ALL		
M4182B1044/U	FUNCTIONAL	M4185B1058/U			ALL		
M4182B1051/U	DIRECT	M4185B1058/U	WITH	1	ALL		
M4185A1027/U	DIRECT	M8185D1006/U	WITH	1	ALL	HONEYWELL	
M4185A1027/U	FUNCTIONAL	M4185A1001		3	ALL	HONEYWELL	
M4185B1017/U	DIRECT	M4185B1058/U		1	ALL		
M4185B1025/U	DIRECT	M4185B 1074		1	ALL	HONEYWELL	
M4185B1025/U	DIRECT	M8185D1006/U	WITH		ALL		
M4185B1033/U	DIRECT	M4185B1009/U	WITH	1	ALL		
M4185B1041/U	DIRECT	M8185D1006/U	WITH	1	TRADE	HONEYWELL	
M4185B1041/U	FUNCTIONAL	M4185B1025/U	WITH	4	TRADE	HONEYWELL	
M4185B1066/U	DIRECT	M8185D1006/U	WITH	1	ALL	HONEYWELL	
M4185B1066/U	FUNCTIONAL	M4185B1058		4	ALL	HONEYWELL	
M4185D1013/U	DIRECT	M8185D1006/u	WITH	1	ALL	HONEYWELL	
M4185E1010/U	DIRECT	M8185D1006/u	WITH	1	ALL	HONEYWELL	
M4186H1005/U	DIRECT	M8185D1006/U	WITH	1	ALL	HONEYWELL	
M4186H1005/U	FUNCTIONAL	M4185B1009			ALL		
M4186L4000/U	FUNCTIONAL	M8185D1006/U	WITH	1	ALL	HONEYWELL	
M445A1000/U	DIRECT	M8185D1006/U	WITH	1	TRADE	HONEYWELL	
M445A1000/U	FUNCTIONAL	M4185B1009/U		4	TRADE	HONEYWELL	
M445A1042/U	DIRECT	M8185D1006/U	WITH	1	TRADE	HONEYWELL	
M445A1042/U	FUNCTIONAL	M4185B1058/U		4	TRADE	HONEYWELL	
M445A1067/U	DIRECT	M8185D1006/U	WITH	1	TRADE	HONEYWELL	
M445A1067/U	FUNCTIONAL	M4185B1058/U	WITH	4	TRADE	HONEYWELL	
M445C1008/U	DIRECT	M8185D1006/U	WITH	1	TRADE	HONEYWELL	
M445C1008/U	FUNCTIONAL	M4185B1009/U		4	TRADE	HONEYWELL	
M445D1007/U	DIRECT	M8185D1006/U	WITH	1	TRADE	HONEYWELL	
M445D1007/U	FUNCTIONAL	M4185A1001/U		3	TRADE	HONEYWELL	
M6161A1004/U	TRADE EQUIV	M6184A1023/U		1	ALL		
M6161A1004/U	FUNCTIONAL	M6184A1015/U			TRADE		
M6161B1002/U	DIRECT	M6184D1035/U	WITH	1	ALL	HONEYWELL	
M6174A1009/U	FUNCTIONAL	M6184D1035/U		1	ALL	HONEYWELL	
M6181A1018/U	TRADE EQUIV	M6184A1015/U		1	ALL		
M6181A1026/U	DIRECT	M6184D1035/U	OR	1	TRADE	HONEYWELL	
M6181A1026/U	FUNCTIONAL	M6184A1015/U		2	TRADE	HONEYWELL	
M6181A1034/U	TRADE EQUIV	M6184A1023/U		1	ALL		
M6181A1059/U	DIRECT	M6184D1035/U		1	ALL		
M6181F1009/U	TRADE EQUIV	M6184F1014/U		1	TRADE		

Modutrol IV Motor Cross Reference

ITEM NUMBER	REPL TYPE	REPL ITEM	MULTI REPL	REPL SEQ	CHANNEL (BUSI GROUP)	MFG NAME	CUSTOMER REMARKS
M6181F1017/U	DIRECT	M6184D1035/U	WITH	1	ALL	HONEYWELL	
M6181F1017/U	FUNCTIONAL	M6184F1014/U		1	ALL	HONEYWELL	
M6182F1016/U	FUNCTIONAL	M6285A1005-S/U	WITH	1	ALL		
M6184A1007/U	TRADE EQUIV	M6184D1035/U		1	ALL		
M6184A1049/U	DIRECT	M6184D1035/U	WITH	1	ALL	HONEYWELL	
M6184A1049/U	FUNCTIONAL	M6184A1023/U		3	ALL	HONEYWELL	
M6184B1005/U	FUNCTIONAL	M6184D1035/U	WITH	1	ALL	HONEYWELL	
M6184B1013/P	DIRECT	M6184B1013/U		1	ALL		
M6184B1021/U	DIRECT	M6184D1035/U	WITH	1	ALL		
M6184B1021/U	FUNCTIONAL	M6184F1014/U			ALL		
M6184D1050/U	DIRECT	M6184D1035/u		1	ALL	HONEYWELL	
M6184D1050/U	FUNCTIONAL	M6184D1001		2	ALL	HONEYWELL	
M6184F1006/U	FUNCTIONAL	M6184F1014/U		1	ALL	HONEYWELL	
M6184F1006/U	DIRECT	M6184D1035/U			ALL		
M6185D1000/U	DIRECT	M6285A1005/U		1	ALL		
M6191A1008/U	FUNCTIONAL	M6194D1017/U	WITH	1	TRADE	HONEYWELL	
M6191B1006/U	DIRECT	M6194B1011/U	WITH	1	ALL		
M6191B1006/U	FUNCTIONAL	M6194B1011/U			ALL		
M6191D1002/U	FUNCTIONAL	M6194D1017/U		1	ALL		
M6191D1002/U	DIRECT	M6294D1008-S/U		1	ALL		
M6191D1010/U	DIRECT	M6194D1017/U	WITH	1	ALL	HONEYWELL	
M6194A1021/U	FUNCTIONAL	M6194D1017/U		1	TRADE	HONEYWELL	
M6194B1003/U	FUNCTIONAL	M6194B1011/U		1	ALL	HONEYWELL	
M6194B1003/U	DIRECT	M6194D1017/U	WITH		ALL	HONEYWELL	
M6274F1009/U	FUNCTIONAL	M6274F1009-F/U		1	ALL		
M6281F1016/U	FUNCTIONAL	M6284F1013-S/U		1	ALL		
M6282E1009/P	DIRECT	M6282E1009-F/U		1	ALL		
M6282E1009/U	FUNCTIONAL	M6282E1009-F/U		1	ALL		
M6284A1006/U	DIRECT	M6284D1000-S/U		1	TRADE		
M6284A1006/U	FUNCTIONAL	M6284A1055-S/U		2	TRADE		
M6284A1014/U	FUNCTIONAL	M6284A1055/U		1	ALL	HONEYWELL	
M6284A1014/U	DIRECT	M6284D1000/U	WITH		ALL		
M6284A1022/U	FUNCTIONAL	M6284A1055/U		1	ALL	HONEYWELL	
M6284A1022/U	DIRECT	M6284D1000			ALL		
M6284A1030/U	FUNCTIONAL	M6284A1030-S/U		1	ALL		
M6284A1048/U	DIRECT	M6284A1055-S/U		1	ALL		
M6284A1055/U	FUNCTIONAL	M6284A1055-S/U		1	ALL		
M6284A1063/U	DIRECT	M6284D1000-S/U	WITH	1	TRADE	HONEYWELL	
M6284A1071/U	FUNCTIONAL	M6284A1071-S/U		1	ALL		
M6284A1089/U	FUNCTIONAL	M6284A1089-S/U		1	ALL		
M6284A1097/U	FUNCTIONAL	M6284A1097-S/U		1	ALL		
M6284A1113/U	DIRECT	M6284D1000-S/U	WITH	1	ALL		
M6284B1004/U	FUNCTIONAL	M6284B1004-S/U		1	ALL		
M6284C1010/U	FUNCTIONAL	M6284C1010-S/U		1	ALL		
M6284C1028/U	FUNCTIONAL	M6284C1028-S/U		1	ALL		
M6284C1036/U	FUNCTIONAL	M6284D1000-S/U	WITH	1	ALL	HONEYWELL	
M6284C1044/U	FUNCTIONAL	M6284C1044-S/U		1	ALL		
M6284D1000/U	FUNCTIONAL	M6284D1000-S/U		1	ALL		
M6284D1000/U	UPGRADE	M6284D1032-F/U		1	ALL		Same as M6284D1000-s But With Linear 10K Feedback
M6284D1026/U	FUNCTIONAL	M6284D1026-S/U		1	ALL		
M6284D4004/U	FUNCTIONAL	M6284D4004-S/U		1	ALL		
M6284F1005/U	DIRECT	M6284D1000-S/U	WITH	1	TRADE	HONEYWELL	
M6284F1005/U	FUNCTIONAL	M6284F1013-S/U		3	TRADE	HONEYWELL	
M6284F1013/U	FUNCTIONAL	M6284F1013-S/U		1	ALL		
M6284F1021/U	DIRECT	M6284D1000/U	WITH		TRADE	HONEYWELL	
M6284F1021/U	FUNCTIONAL	M6284F1013/U			TRADE	HONEYWELL	
M6284F1039/U	FUNCTIONAL	M6284F1039-S/U		1	ALL		
M6284F1054/U	FUNCTIONAL	M6284F1062-S/U	WITH	1	ALL		
M6284F1062/U	FUNCTIONAL	M6284F1062-S/U		1	ALL		
M6284F1078/U	FUNCTIONAL	M6284F1078-F/U		1	ALL		
M6285A1005/U	FUNCTIONAL	M6285A1005-S/U		1	ALL		
M6285A1013/U	DIRECT	M6285A1005-S/U		1	ALL		
M6285A1039/U	FUNCTIONAL	M6285A1039-S/U		1	ALL		
M6285A1047/U	FUNCTIONAL	M6285A1047-S/U		1	ALL		
M6285A4009/U	FUNCTIONAL	M6285A4009-S/U		1	ALL		
M6285C1001/U	FUNCTIONAL	M6285C1001-S/U		1	ALL		
M6285F1001/U	FUNCTIONAL	M6285F1001-F/U		1	ALL		
M6286G1001/U	FUNCTIONAL	M6285A1005-S/U		1	ALL		
M6286G1019/U	FUNCTIONAL	M6285A1005/U	WITH	1	ALL	HONEYWELL	
M6294A1004/U	DIRECT	M6294D1008-S/U	WITH	1	ALL	HONEYWELL	
M6294B1002/U	FUNCTIONAL	M6294D1008/U	WITH	1	ALL	HONEYWELL	
M6294B1036/U	FUNCTIONAL	M6294B1036-S/U		1	ALL		

CROSS REFERENCE

Modutrol IV Motor Cross Reference

ITEM NUMBER	REPL TYPE	REPL ITEM	MULTI REPL	REPL SEQ	CHANNEL (BUSI GROUP)	MFG NAME	CUSTOMER REMARKS
M6294D1008/U	FUNCTIONAL	M6294D1008-S/U		1	ALL		
M6294F1009/U	FUNCTIONAL	M6294F1009-F/U		1	ALL		
M6294F1017/U	FUNCTIONAL	M6294F1017-F/U		1	ALL		
M640A1006/U	FUNCTIONAL	M640A1121/U		1	TRADE	HONEYWELL	
M640B1021/U	FUNCTIONAL	M640B1062/U		1	TRADE	HONEYWELL	
M6410A1003/U	DIRECT	M6410A1029/U		1	TRADE	HONEYWELL	
M6410A1011/U	DIRECT	M6410A1029/U		1	TRADE	HONEYWELL	
M644A1008/U	DIRECT	M6184D1035/U		1	TRADE	HONEYWELL	
M644A1016/U	DIRECT	M6184D1035/U		1	TRADE	HONEYWELL	
M644A1024/U	DIRECT	M6184D1035/U	OR	1	TRADE	HONEYWELL	
M644A1024/U	FUNCTIONAL	M6184A1015/U		2	TRADE	HONEYWELL	
M644B1007/U	DIRECT	M6184D1035/U	WITH	1	TRADE	HONEYWELL	
M644B1049/U	DIRECT	M6184D1035/U	WITH	1	TRADE	HONEYWELL	
M644B1049/U	FUNCTIONAL	M6184A1023/U		3	TRADE	HONEYWELL	
M644B1056/U	DIRECT	M6194D1017/U	WITH	1	TRADE	HONEYWELL	
M644C1006/U	DIRECT	M6184D1035/U	OR	1	TRADE	HONEYWELL	
M644C1006/U	FUNCTIONAL	M6184D1001/U		2	TRADE	HONEYWELL	
M644C1014/U	DIRECT	M6194D1017/U		1	ALL	HONEYWELL	
M644D1005/U	DIRECT	M6184D1035/U	WITH	1	TRADE	HONEYWELL	
M644E1012/U	DIRECT	M6194D1017/U	WITH	1	TRADE	HONEYWELL	
M6520B1008/U	FUNCTIONAL	M6410B1001/U		1	ALL	HONEYWELL	
M6520B1016/U	FUNCTIONAL	M6410B1001/U		1	ALL	HONEYWELL	
M7161A1002/U	DIRECT	M9164D1009/U	WITH	1	ALL		
M7161G1009/U	DIRECT	M9164D1009/U	WITH	1	ALL	HONEYWELL	
M7161G1009/U	FUNCTIONAL	M7164G1030/U		1	ALL	HONEYWELL	
M7161G1017/U	DIRECT	M9184D1021/U	WITH	1	ALL		
M7164A1009/U	FUNCTIONAL	M9164D1009/U	WITH	1	ALL	HONEYWELL	
M7164B1007/U	FUNCTIONAL	M9164D1009/U	WITH	1	ALL	HONEYWELL	
M7164G1006/U	FUNCTIONAL	M7164G1030/U		1	ALL	HONEYWELL	
M7164G1006/U	DIRECT	M9164D1009/U	WITH	1	ALL	HONEYWELL	
M7164G1014/U	FUNCTIONAL	M9164D1009/U	WITH	1	ALL	HONEYWELL	
M7164G1022/U	FUNCTIONAL	M9164D1009/U	WITH	1	ALL	HONEYWELL	
M7184A1005/U	FUNCTIONAL	M9184D1021/U	WITH	1	ALL	HONEYWELL	
M7185A1004/U	DIRECT	M9185D1004/U	WITH	1	ALL	HONEYWELL	
M7186G1000/U	FUNCTIONAL	M9185D1004/U	WITH	1	TRADE	HONEYWELL	
M7215A1024	TRADE EQUIV	M7215A1008		1	TRADE	HONEYWELL	
M7272A1008/U	FUNCTIONAL	M9175D1014/U	WITH	1	ALL	HONEYWELL	
M7274A1006/U	DIRECT	M9184D1021/U	WITH	1	ALL	HONEYWELL	
M7274G1003/U	DIRECT	M9184D1021/U	WITH	1	ALL	HONEYWELL	
M7281A1007/U	FUNCTIONAL	M7284A1004/U		1	ALL	HONEYWELL	
M7281Q1002/U	DIRECT	M7284Q1009/U		1	ALL	HONEYWELL	
M7282A1006/U	DIRECT	M9185D1004/U	WITH	1	ALL	HONEYWELL	
M7282A1006/U	FUNCTIONAL	M7285A1003/U		1	ALL	HONEYWELL	
M7282A1014/P	DIRECT	M7282A1014/U		1	ALL		
M7282C1002/U	FUNCTIONAL	M9185D1004/U	WITH	1	ALL	HONEYWELL	
M7282D1000/P	DIRECT	M7282D1000/U		1	ALL		
M7284A1020/U	FUNCTIONAL	M7284A1012/U		1	ALL	HONEYWELL	
M7284A1020/U	DIRECT	M9184D1021/U	WITH	1	ALL	HONEYWELL	
M7284A1046/U	DIRECT	M7284A1004		1	ALL	HONEYWELL	
M7284C1018/U	DIRECT	M7284C1000/U		1	ALL		
M7284C1026/U	FUNCTIONAL	M7284C1000/U	WITH	1	ALL	HONEYWELL	Includes 220741A
M7284C1026/U	DIRECT	M9184D1021/U		1	ALL	HONEYWELL	
M7284C1059/U	DIRECT	M7284C1083/U		1	ALL	HONEYWELL	
M7284C1067/U	DIRECT	M7284C1091/U		1	ALL	HONEYWELL	
M7284G1001/U	FUNCTIONAL	M7284A1079/U		1	ALL	HONEYWELL	
M7284G1001/U	DIRECT	M9184D1021/U	WITH	1	TRADE	HONEYWELL	
M7284Q1017/U	DIRECT	M7284Q1009/U		1	ALL		
M7284Q1033/U	DIRECT	M7284Q1082/U		1	ALL	HONEYWELL	
M7284Q1041/U	DIRECT	M7284Q1090/U		1	ALL		
M7284Q1074/U	DIRECT	M7284Q1082/U	WITH	1	ALL		
M7285A1011/U	DIRECT	M7285A1003/U		1	ALL		
M7285A1029/U	DIRECT	M9185D1004/U		1	ALL	HONEYWELL	
M7285A1037/U	DIRECT	M9185D1004/U		1	ALL	HONEYWELL	
M7285A1052/U	DIRECT	M9185D1004/U	WITH	1	ALL		
M7285B1001/U	FUNCTIONAL	M9185D1004/U	WITH	1	ALL	HONEYWELL	
M7285C1017/U	DIRECT	M7285C1009/U		1	ALL		
M7285C1025/U	DIRECT	M9185D1004/U		1	ALL	HONEYWELL	
M7285C1033/U	DIRECT	M9185D1004/U		1	TRADE	HONEYWELL	
M7285Q1016/U	DIRECT	M7285Q1008/U		1	ALL		
M7294G1009/U	DIRECT	M7294A1010/U		1	ALL		
M734A1015/U	FUNCTIONAL	M7964A1001/U		1	TRADE	HONEYWELL	
M734B1048/U	FUNCTIONAL	M7964B1017/U		1	TRADE	HONEYWELL	
M734D1004/U	DIRECT	M9164D1009/U	WITH	1	TRADE	HONEYWELL	

Modutrol IV Motor Cross Reference

ITEM NUMBER	REPL TYPE	REPL ITEM	MULTI REPL	REPL SEQ	CHANNEL (BUSI GROUP)	MFG NAME	CUSTOMER REMARKS
M734D1012/U	DIRECT	M9164D1009/U	WITH	1	TRADE	HONEYWELL	
M734D1038/U	DIRECT	M9164D1009/U		0	ALL	HONEYWELL	
M734H1000/U	DIRECT	M9164D1009/U	WITH	1	TRADE	HONEYWELL	
M734H1018/U	DIRECT	M9164D1009/U	WITH	1	TRADE	HONEYWELL	
M734H1026/U	FUNCTIONAL	M9164D1009/U	WITH	1	TRADE	HONEYWELL	
M734J1015/U	FUNCTIONAL	M9164D1009/U	WITH	1	TRADE	HONEYWELL	
M734J1023/U	DIRECT	M9164D1009/U	WITH	1	TRADE	HONEYWELL	
M734J1023/U	FUNCTIONAL	M7164A1017/U		3	TRADE	HONEYWELL	
M734J1031/U	DIRECT	M9164D1009/U	WITH	1	TRADE	HONEYWELL	
M734J1056/U	DIRECT	M9164D1009/U	WITH	1	TRADE	HONEYWELL	
M734J1056/U	FUNCTIONAL	M7164A1017/U		3	TRADE	HONEYWELL	
M734J1072/U	DIRECT	M9164D1009/U	WITH	1	TRADE	HONEYWELL	
M7364A1007/U	DIRECT	M9164D1009/U	WITH	1	ALL	HONEYWELL	
M7364A1015/U	FUNCTIONAL	M9164D1009/U	WITH	1	TRADE	HONEYWELL	
M7364A1023/U	FUNCTIONAL	M9164D1009/U	WITH	1	TRADE	HONEYWELL	
M7364A1031/U	DIRECT	M9164A1070/U	WITH		ALL	HONEYWELL	
M7384A1003/U	FUNCTIONAL	M9184D1021/U	WITH	1	ALL	HONEYWELL	
M7384A1011/U	FUNCTIONAL	M9184D1021/U	WITH	1	ALL	HONEYWELL	
M7385A1002/U	FUNCTIONAL	M9185D1004/U	WITH	1	ALL	HONEYWELL	
M7385A1010/U	FUNCTIONAL	M9185D1004/U	WITH	1	TRADE	HONEYWELL	
M7410C1007/U	FUNCTIONAL	M6410A1029		1	TRADE		
M7410C1015/U	FUNCTIONAL	M6410A3017/U		1	TRADE		
M7410E1010/U	FUNCTIONAL	M7410E1010/U		1	ALL	HONEYWELL	
M7410E1036/U	FUNCTIONAL	M7410F1000/U		1	TRADE	HONEYWELL	
M7415A1022/U	FUNCTIONAL	M7415A1006/U		1	ALL	HONEYWELL	
M744A1006/U	FUNCTIONAL	M9184D1021/U	WITH	1	TRADE	HONEYWELL	
M744A1014/U	FUNCTIONAL	M9184D1021/U	WITH	1	TRADE	HONEYWELL	
M744D1003/U	FUNCTIONAL	M9184D1021/U	WITH	1	TRADE	HONEYWELL	
M744S1005/U	DIRECT	M9184D1021/U	WITH	1	TRADE	HONEYWELL	
M744S1005/U	FUNCTIONAL	M7284A1004/U		4	TRADE	HONEYWELL	
M744S1013/U	DIRECT	M9184D1021/U	WITH	1	TRADE	HONEYWELL	
M744S1013/U	FUNCTIONAL	M7284A1012/U		4	TRADE	HONEYWELL	
M744T1004/U	DIRECT	M9184D1021/U	WITH	1	TRADE	HONEYWELL	
M744T1012/U	DIRECT	M9184D1021/U	WITH	1	TRADE	HONEYWELL	
M744T1012/U	FUNCTIONAL	M7284C1018/U		4	TRADE	HONEYWELL	
M744Y1009/U	DIRECT	M9184D1021/U	WITH	1	TRADE	HONEYWELL	
M744Y1017/U	DIRECT	M9184D1021/U	WITH	1	TRADE	HONEYWELL	
M745A1003/U	FUNCTIONAL	M9185D1004/U	WITH	1	TRADE	HONEYWELL	
M745A1011/U	FUNCTIONAL	M9185D1004/U	WITH	1	TRADE	HONEYWELL	
M745G1007/U	FUNCTIONAL	M9185D1004/U	WITH	1	TRADE	HONEYWELL	
M745L1027/U	FUNCTIONAL	M9185D1004/U	WITH	1	TRADE	HONEYWELL	
M745L1043/U	FUNCTIONAL	M9185D1004/U	WITH	1	TRADE	HONEYWELL	
M745P1007/U	FUNCTIONAL	M9185D1004/U	WITH	1	TRADE	HONEYWELL	
M745S1002/U	FUNCTIONAL	M9185D1004/U	WITH	1	TRADE	HONEYWELL	
M745S1010/U	DIRECT	M9185D1004/U	WITH	1	TRADE	HONEYWELL	
M745S1010/U	FUNCTIONAL	M7285A1003/U		4	TRADE	HONEYWELL	
M745T1019/U	FUNCTIONAL	M9185D1004/U	WITH	1	TRADE	HONEYWELL	
M745Y1006/U	DIRECT	M9185D1004/U	WITH	1	TRADE	HONEYWELL	
M745Y1014/U	FUNCTIONAL	M9185D1004/U	WITH	1	TRADE	HONEYWELL	
M765K1000/U	FUNCTIONAL	M9175D1014/U	WITH	1	TRADE	HONEYWELL	
M765L1017/U	FUNCTIONAL	M9175D1014/U	WITH	1	TRADE	HONEYWELL	
M7675A1001/U	FUNCTIONAL	M9185D1004/U	WITH	1	ALL		
M7675A1019/U	FUNCTIONAL	M9185D1004/U	WITH	1	TRADE	HONEYWELL	
M7675G1008/U	DIRECT	M9185D1004/U	WITH	1	ALL		
M7682A1010/U	DIRECT	M9185D1004/U	WITH	1	ALL		
M7685A1009/U	FUNCTIONAL	M9185D1004/U	WITH	1	TRADE	HONEYWELL	
M7685A1017/U	FUNCTIONAL	M9185D1004/U	WITH	1	ALL	HONEYWELL	
M7685A1025/U	FUNCTIONAL	M9185D1004/U	WITH	1	TRADE	HONEYWELL	
M7964A1001/U	FUNCTIONAL	M7964A1001/u		1	ALL	HONEYWELL	
M80AAA-3	FUNCTIONAL	M6284D1000/U	OR	1	TRADE	JOHNSON CONTROLS	
M80AAA-3	FUNCTIONAL	M6284F1013/U			TRADE	JOHNSON CONTROLS	
M80AAB-1	FUNCTIONAL	M6284D1000	WITH		TRADE	JOHNSON CONTROLS	
M80AAB-1	FUNCTIONAL	M6284F1013			TRADE	JOHNSON CONTROLS	
M80ACA-1	FUNCTIONAL	M6285A1005/U		1	TRADE	JOHNSON CONTROLS	
M80ADA-1	FUNCTIONAL	M6285A1005/U		1	TRADE	JOHNSON CONTROLS	
M80BAA-1	FUNCTIONAL	M9184D1021/U	OR	1	TRADE	JOHNSON CONTROLS	
M80BAA-1	FUNCTIONAL	M9184A1019/U		2	TRADE	JOHNSON CONTROLS	
M80BAA-4	FUNCTIONAL	M9184D1005/U		1	TRADE	JOHNSON CONTROLS	
M80BCA-1	FUNCTIONAL	M9185D1004/U		1	TRADE	JOHNSON CONTROLS	
M80BDA-1	FUNCTIONAL	M9185D1004/U		1	TRADE	JOHNSON CONTROLS	
M80BEA-1	FUNCTIONAL	M9185D1004/U	OR	1	TRADE	JOHNSON CONTROLS	
M80BEA-1	FUNCTIONAL	M9185A1018/U		2	TRADE	JOHNSON CONTROLS	
M80FAA-2	FUNCTIONAL	M9184D1021/U	OR	1	TRADE	JOHNSON CONTROLS	

CROSS REFERENCE

Modutrol IV Motor Cross Reference

ITEM NUMBER	REPL TYPE	REPL ITEM	MULTI REPL	REPL SEQ	CHANNEL (BUSI GROUP)	MFG NAME	CUSTOMER REMARKS
M80FAA-2	FUNCTIONAL	M9184A1019/U		2	TRADE	JOHNSON CONTROLS	
M80FCA-2	FUNCTIONAL	M9185D1004/U		1	TRADE	JOHNSON CONTROLS	
M80FDA-1	FUNCTIONAL	M9185D1004/U		1	TRADE	JOHNSON CONTROLS	
M80FEA-1	FUNCTIONAL	M9185D1004/U	OR	1	TRADE	JOHNSON CONTROLS	
M80FEA-1	FUNCTIONAL	M9185A1018/U		2	TRADE	JOHNSON CONTROLS	
M80FFA-1	FUNCTIONAL	M9185D1004/U	OR	1	TRADE	JOHNSON CONTROLS	
M80FFA-1	FUNCTIONAL	M9185A1018/U		2	TRADE	JOHNSON CONTROLS	
M80HAB-1	FUNCTIONAL	M9184D1021/U	OR	1	TRADE	JOHNSON CONTROLS	
M80HAB-1	FUNCTIONAL	M9184F1034/U		2	TRADE	JOHNSON CONTROLS	
M80HAC-1	FUNCTIONAL	M9184D1021/U	OR	1	TRADE	JOHNSON CONTROLS	
M80HAC-1	FUNCTIONAL	M9184F1034/U		2	TRADE	JOHNSON CONTROLS	
M80JAA-2	FUNCTIONAL	M9184D1021/U	OR	1	TRADE	JOHNSON CONTROLS	
M80JAA-2	FUNCTIONAL	M9184A1019/U		2	TRADE	JOHNSON CONTROLS	
M80JAA--2	FUNCTIONAL	M9184A1019/U	OR		TRADE	JOHNSON CONTROLS	
M80JAA--2	FUNCTIONAL	M9184D1021/U			TRADE	JOHNSON CONTROLS	
M80JAB-1	FUNCTIONAL	M9184D1021/U	WITH	1	TRADE	JOHNSON CONTROLS	
M80JAB-1	FUNCTIONAL	M9184F1018/U		3	TRADE	JOHNSON CONTROLS	
M80JAB--1	FUNCTIONAL	M9184D1021/U	WITH		TRADE	JOHNSON CONTROLS	
M80JAB--1	FUNCTIONAL	M9184F1034/U			TRADE	JOHNSON CONTROLS	
M80JAC-1	FUNCTIONAL	M9184D1021/U	WITH	1	TRADE	JOHNSON CONTROLS	
M80JAC-1	FUNCTIONAL	M9184F1018/U		3	TRADE	JOHNSON CONTROLS	
M80JAC--1	FUNCTIONAL	M9484E1017/U			TRADE	JOHNSON CONTROLS	
M80JCA-2	FUNCTIONAL	M9185D1004/U	OR	1	TRADE	JOHNSON CONTROLS	
M80JCA-2	FUNCTIONAL	M9185A1018/U		2	TRADE	JOHNSON CONTROLS	
M80JCA--2	FUNCTIONAL	M9185A1018/U	OR		TRADE	JOHNSON CONTROLS	
M80JCA--2	FUNCTIONAL	M9185D1004/U			TRADE	JOHNSON CONTROLS	
M80JCB-1	FUNCTIONAL	M9185D1004/U	WITH	1	TRADE	JOHNSON CONTROLS	
M80JCB-1	FUNCTIONAL	M9185E1001/U		3	TRADE	JOHNSON CONTROLS	
M80JCB--1	FUNCTIONAL	M9185D1004/U	WITH		TRADE	JOHNSON CONTROLS	
M80JCB--1	FUNCTIONAL	M9185E1019/U			TRADE	JOHNSON CONTROLS	
M8110AAB-1	FUNCTIONAL	M8185D1006/U	WITH	1	TRADE	JOHNSON CONTROLS	
M8175B1002/U	FUNCTIONAL	M8185D1006/U	WITH	1	ALL	HONEYWELL	
M8182A1005/U	DIRECT	M8185D1006/U		1	ALL		
M8182B1011/U	DIRECT	M8185D1006/U	WITH	1	ALL		
M8185A1002/U	DIRECT	M8185D1006/U		1	ALL		
M8185A1010/U	DIRECT	M8185D1006/U		1	ALL		
M8185B1000/U	DIRECT	M8185D1006/U	WITH	1	ALL	HONEYWELL	
M8185B1018/U	FUNCTIONAL	M8185D1006/U		1	TRADE	HONEYWELL	
M8185B1026/U	FUNCTIONAL	M8185A1028/U		1	TRADE	HONEYWELL	
M8185B1034/U	DIRECT	M8185D1006/U	WITH	1	ALL		
M8186G1008/U	DIRECT	M8185D1006/U		1	ALL		
M81AAA-12	FUNCTIONAL	M6184D1035/U	OR	1	TRADE	JOHNSON CONTROLS	
M81AAA-12	FUNCTIONAL	M6184F1006/U		2	TRADE	JOHNSON CONTROLS	
M81AAA--12	DIRECT	M6184D1035/U			TRADE	JOHNSON CONTROLS	
M81AAA--12	FUNCTIONAL	M6184F1014/U			TRADE	JOHNSON CONTROLS	
M81AAA-13	FUNCTIONAL	M6184D1035/U	OR	1	TRADE	JOHNSON CONTROLS	
M81AAA-13	FUNCTIONAL	M6184D1001/U		2	TRADE	JOHNSON CONTROLS	
M81AAA--13	FUNCTIONAL	M6184D1001			TRADE	JOHNSON CONTROLS	
M81AAA--13	DIRECT	M6184D1035/U			TRADE	JOHNSON CONTROLS	
M81AAB-5	FUNCTIONAL	M6184D1035/U	WITH	1	TRADE	JOHNSON CONTROLS	
M81AAB-5	FUNCTIONAL	M6184F1006/U		3	TRADE	JOHNSON CONTROLS	
M81AAB--5	DIRECT	M6184D1035/U	WITH		TRADE	JOHNSON CONTROLS	
M81AAB--5	FUNCTIONAL	M6184F1015/U			TRADE	JOHNSON CONTROLS	
M81AAC-1	FUNCTIONAL	M6184D1035/U	WITH	1	TRADE	JOHNSON CONTROLS	
M81ACA-3	FUNCTIONAL	M8185D1006/U	OR	1	TRADE	JOHNSON CONTROLS	
M81ACB-1	FUNCTIONAL	M8185D1006/U	WITH	1	TRADE	JOHNSON CONTROLS	
M81ADA-2	DIRECT	M8185D1006/U	WITH	1	TRADE	JOHNSON CONTROLS	
M81ADA-2	FUNCTIONAL	M4185B1058/U	WITH	3	TRADE	JOHNSON CONTROLS	
M81AEA-2	FUNCTIONAL	M8185D1006/U	WITH	1	TRADE	JOHNSON CONTROLS	
M81AEA-2	FUNCTIONAL	M4185B1009/U		3	TRADE	JOHNSON CONTROLS	
M81AFA-2	FUNCTIONAL	M8185D1006/U	OR	1	TRADE	JOHNSON CONTROLS	
M81AFB-1	DIRECT	M8185D1006/U	WITH	1	TRADE	JOHNSON CONTROLS	
M81AFB-1	FUNCTIONAL	M4185B1058/U	WITH		TRADE	JOHNSON CONTROLS	
M835A1036/U	FUNCTIONAL	M835A1051/U		1	TRADE	HONEYWELL	
M836A1034/U	FUNCTIONAL	M836A1042			TRADE	HONEYWELL	
M836B1025/U	FUNCTIONAL	M836B1033/u			TRADE	HONEYWELL	
M836B1041/U	FUNCTIONAL	M836B1033/U			TRADE	HONEYWELL	
M8414A1005/U	FUNCTIONAL	M8414A1005/U		1	ALL	HONEYWELL	
M845A1001/U	FUNCTIONAL	M8185D1006/U	WITH	1	TRADE	HONEYWELL	
M845A1027/U	DIRECT	M8185D1006/U	WITH	1	TRADE	HONEYWELL	
M845A1035/U	FUNCTIONAL	M8185D1006/U	WITH	1	TRADE	HONEYWELL	
M845A1035/U	FUNCTIONAL	M4185B1058/U		4	TRADE	HONEYWELL	
M845B1018/U	DIRECT	m8185D1006	WITH	1	TRADE		

Modutrol IV Motor Cross Reference

ITEM NUMBER	REPL TYPE	REPL ITEM	MULTI REPL	REPL SEQ	CHANNEL (BUSI GROUP)	MFG NAME	CUSTOMER REMARKS
M845C1009/U	FUNCTIONAL	M8185D1006/U	OR	1	TRADE	HONEYWELL	
M845D1024/U	FUNCTIONAL	M8185D1006/U		1	TRADE	HONEYWELL	
M845E1007/U	DIRECT	M8185D1006/U	WITH	1	TRADE	HONEYWELL	
M845E1007/U	FUNCTIONAL	M4185B1009/u		4	TRADE	HONEYWELL	
M847A1031	FUNCTIONAL	M847A1080			TRADE	HONEYWELL	
M847A1031/U	DIRECT	M847A1080/U		1	ALL	HONEYWELL	
M847A1049/U	FUNCTIONAL	M847A1072/U		1	TRADE	HONEYWELL	
M847D1004/B	FUNCTIONAL	M847D1012/U		1	ALL		
M847D1004/U	FUNCTIONAL	M847D1012/U		1	ALL		
M886B1004/U	FUNCTIONAL	M8415A1004/U		1	TRADE		
M9161A1016/U	DIRECT	M9164D1009/U		1	ALL	HONEYWELL	
M9161A1016/U	FUNCTIONAL	M9164A1005/U			ALL	HONEYWELL	
M9161A1024/U	DIRECT	M9164A1005/U		1	ALL		
M9161A1032/P	DIRECT	M9164A1005/U		1	ALL		
M9161A1040/U	DIRECT	M9184D1021/U	WITH	1	ALL	HONEYWELL	
M9161A1040/U	FUNCTIONAL	M9164A1005			ALL	HONEYWELL	
M9161C1004/U	DIRECT	M9164C1001/U	WITH	1	ALL		
M9161C1004/U	FUNCTIONAL	M9164C1068/U		1	ALL		
M9161C1012/U	DIRECT	M9164C1068/U		1	ALL		
M9164A1021/U	DIRECT	M9164A1005/U		1	ALL		
M9164A1047/U	FUNCTIONAL	M9164A1088/U		1	ALL	HONEYWELL	
M9164A1047/U	DIRECT	M9164D1009/U	WITH		TRADE	HONEYWELL	
M9164A1054/U	FUNCTIONAL	M9164A1005/U		1	ALL	HONEYWELL	
M9164A1054/U	DIRECT	M9164D1009/U	WITH		ALL	HONEYWELL	
M9164A1062/U	FUNCTIONAL	M9164A1005/U		1	ALL	HONEYWELL	
M9164A1062/U	DIRECT	M9164D1009/U			TRADE	HONEYWELL	
M9164A1088/U	DIRECT	M9164A1013/U		1	ALL		
M9164A1120/U	DIRECT	M9164D1009/U		1	ALL	HONEYWELL	
M9164A1120/U	FUNCTIONAL	M9164A1005/U			ALL	HONEYWELL	
M9164C1019/U	FUNCTIONAL	M9164C1068/U		1	ALL	HONEYWELL	
M9164C1019/U	DIRECT	M9164D1009/U	WITH		ALL	HONEYWELL	
M9164C1027/U	FUNCTIONAL	M9164D1009/U	WITH	1	ALL	HONEYWELL	
M9164C1035/U	FUNCTIONAL	M9164C1068/U		1	ALL	HONEYWELL	
M9164C1035/U	DIRECT	M9164D1009/U	WITH		ALL	HONEYWELL	
M9164C1050/U	DIRECT	M9164C1068/U		1	ALL		
M9171A1006/U	FUNCTIONAL	M9174B1027/U	WITH	1	TRADE	HONEYWELL	
M9171A1006/U	FUNCTIONAL	M9174B1043/U		3	TRADE	HONEYWELL	
M9171B1004/U	FUNCTIONAL	M9174B1027/U		1	ALL		
M9171B1004/U	DIRECT	M9184D1021/U	WITH	1	ALL		
M9171B1012/U	FUNCTIONAL	M9174D1007/U	WITH	1	TRADE	HONEYWELL	
M9171C1002/P	DIRECT	M9174C1025/P		1	ALL		
M9171C1002/U	DIRECT	M9174C1025/U		1	ALL	HONEYWELL	
M9171C1002/U	FUNCTIONAL	M9174C1025/u	WITH		ALL	HONEYWELL	
M9174B1001/U	FUNCTIONAL	M9174B1043/U		1	ALL	HONEYWELL	
M9174B1001/U	DIRECT	M9174D1007	WITH		ALL	HONEYWELL	
M9174B1019/U	FUNCTIONAL	M9174B1027/U		1	ALL	HONEYWELL	
M9174B1019/U	DIRECT	M9174D1007/U	WITH		ALL	HONEYWELL	
M9174B1027/P	FUNCTIONAL	M9174B1027/U		1	ALL		
M9174B1043/U	DIRECT	M9174B1027/U		1	ALL		
M9174C1009/U	FUNCTIONAL	M9174C1033/U		1	ALL	HONEYWELL	
M9174C1009/U	DIRECT	M9174D1007/U	WITH		ALL	HONEYWELL	
M9174C1017/U	FUNCTIONAL	M9174C1025/U		1	ALL	HONEYWELL	
M9174C1017/U	DIRECT	M9174D1007/U	WITH		ALL	HONEYWELL	
M9174C1033/P	FUNCTIONAL	M9174C1033/U		1	ALL		
M9175A1010/U	DIRECT	M9185A1018/U		1	ALL	HONEYWELL	
M9175A1036/U	FUNCTIONAL	M9185d1004/U	WITH	1	ALL	HONEYWELL	
M9175A1051/P	DIRECT	M9185A1018/U		1	ALL		
M9175A1051/U	DIRECT	M9185A1018/U		1	ALL		
M9175A1077/U	FUNCTIONAL	M9185D1004/U		1	ALL	HONEYWELL	
M9175D1006/U	FUNCTIONAL	M9185D1004/U			ALL	HONEYWELL	
M9175D1006/U	FUNCTIONAL	M9185A1018/U	WITH	1	TRADE		
M9175D1014/U	TRADE EQUIV	M9185D1004/U	WITH	1	ALL		
M9181A1012/P	DIRECT	M9184A1019/U		1	ALL		
M9181A1012/U	DIRECT	M9184A1019/U		1	ALL		
M9181B1002/U	DIRECT	M9184D1021/U	WITH	1	TRADE	HONEYWELL	
M9181B1010/U	FUNCTIONAL	M9184D1021/U	WITH	1	TRADE	HONEYWELL	
M9181D1008/U	DIRECT	M9184D1021/U	OR	1	TRADE	HONEYWELL	
M9181D1008/U	FUNCTIONAL	M9184D1005/U		2	TRADE	HONEYWELL	
M9182A1011/P	DIRECT	M9185A1018/U		1	ALL		
M9182A1029/U	DIRECT	M9185A1018/U		1	ALL		
M9182A1052/U	DIRECT	M9185A1018/U	WITH	1	ALL		
M9182A1060/U	FUNCTIONAL	M9185D1004/U	WITH	1	ALL	HONEYWELL	
M9182C1009/U	DIRECT	M9185C1006/U		1	ALL		

Modutrol IV Motor Cross Reference

ITEM NUMBER	REPL TYPE	REPL ITEM	MULTI REPL	REPL SEQ	CHANNEL (BUSI GROUP)	MFG NAME	CUSTOMER REMARKS
M9182C1017/U	FUNCTIONAL	M9185D1004/U	WITH	1	ALL	HONEYWELL	
M9182D1015/U	FUNCTIONAL	M9185D1004/U		1	ALL	HONEYWELL	
M9182D1031/U	FUNCTIONAL	M9185D1004/U	WITH	1	ALL	HONEYWELL	
M9182D4001/U	DIRECT	M9185D4008/U		1	TRADE	HONEYWELL	
M9182D4001/U	FUNCTIONAL	M9185D1004/U			TRADE	HONEYWELL	
M9182W1002/U	FUNCTIONAL	M9185D1004/U	WITH	1	ALL	HONEYWELL	
M9183G1009/U	DIRECT	M9185D1004/U	OR	1	TRADE	HONEYWELL	
M9183G1009/U	FUNCTIONAL	M9185A1018/U		2	TRADE	HONEYWELL	
M9184A1001/U	DIRECT	M9184D1021/U		1	ALL	HONEYWELL	
M9184A1027	DIRECT	M9184D1021/U		1	ALL	HONEYWELL	
M9184A1027	FUNCTIONAL	M9184A1035/U			ALL	HONEYWELL	
M9184A1035/U	DIRECT	M9184D1021/U		1	ALL		
M9184A1035/U	FUNCTIONAL	M9184A1019/U			ALL	HONEYWELL	
M9184B1017/P	FUNCTIONAL	M9184B1017/U		1	ALL		
M9184B1025/P	FUNCTIONAL	M9184B1025/U		1	ALL		
M9184B1033/U	FUNCTIONAL	M9184D1021/U	WITH	1	TRADE	HONEYWELL	
M9184B1033/U	FUNCTIONAL	M9184F1034/U		3	TRADE	HONEYWELL	
M9184B1041/U	FUNCTIONAL	M9184D1021/U	WITH	1	TRADE	HONEYWELL	
M9184C1007/U	DIRECT	M9184D1021/U		1	ALL	HONEYWELL	
M9184C1007/U	FUNCTIONAL	M9184C1031/U			ALL	HONEYWELL	
M9184C1049/P	FUNCTIONAL	M9184C1049/U		1	ALL		
M9184D1013/U	DIRECT	M9184D1021/U		1	ALL		
M9184F1000/U	DIRECT	M9184F1034/U		1	ALL		
M9184F1018/U	DIRECT	M9184D1021/U	WITH	1	ALL	HONEYWELL	
M9184F1018/U	FUNCTIONAL	M9184F1034/U			ALL	HONEYWELL	
M9184F1026/U	DIRECT	M9184D1021/U	WITH	1	ALL		
M9184F1026/U	FUNCTIONAL	M9184F1034/U		1	ALL		
M9185A1000/U	FUNCTIONAL	M9185A1018/U		1	ALL	HONEYWELL	
M9185A1000/U	DIRECT	M9185D1004/U	OR	1	ALL	HONEYWELL	
M9185A1026/U	DIRECT	M9185A1018/U		1	ALL		
M9185A1091/U	DIRECT	M9185D1004/U		1	ALL	HONEYWELL	
M9185D1012/U	FUNCTIONAL	M9185D1004/U		1	ALL	HONEYWELL	
M9185E1001/U	FUNCTIONAL	M9185E1019/U		1	ALL	HONEYWELL	
M9185E1001/U	DIRECT	M9185D1004/u	WITH		ALL	HONEYWELL	
M9186G1006/U	FUNCTIONAL	M9185A1018/U		1	ALL		replacement is Normally Closed
M9186G4000/U	FUNCTIONAL	M9185D1004/U		1	ALL	HONEYWELL	
M9186G4000/U	FUNCTIONAL	M9185E4005/U	OR	1	ALL	HONEYWELL	
M934A1201/U	FUNCTIONAL	M9164D1009/U	WITH	1	TRADE	HONEYWELL	
M934A1201/U	FUNCTIONAL	M9164A1013/U		3	TRADE	HONEYWELL	
M934A1219/U	FUNCTIONAL	M9164D1009/U	WITH	1	TRADE	HONEYWELL	
M934A1219/U	FUNCTIONAL	M9164A1005/U		3	TRADE	HONEYWELL	
M934A1227/U	FUNCTIONAL	M9164D1009/U		1	TRADE	HONEYWELL	
M934A1235/U	FUNCTIONAL	M9164D1009/U	WITH	1	TRADE	HONEYWELL	
M934A1235/U	FUNCTIONAL	M9164A1047/U		3	TRADE	HONEYWELL	
M934A1243/U	FUNCTIONAL	M9164D1009/U	WITH	1	TRADE	HONEYWELL	
M934A1243/U	FUNCTIONAL	M9164C1068/U		3	TRADE	HONEYWELL	
M934A1250/U	FUNCTIONAL	M9164D1009/U	WITH	1	TRADE	HONEYWELL	
M934A1268/U	FUNCTIONAL	M9164D1009/U	WITH	1	TRADE	HONEYWELL	
M934A1284/U	FUNCTIONAL	M9164D1009/U	WITH	1	TRADE	HONEYWELL	
M934A1284/U	FUNCTIONAL	M9164A1005/U		3	TRADE	HONEYWELL	
M934A1292/U	FUNCTIONAL	M9164D1009/U	WITH	1	TRADE	HONEYWELL	
M934A1292/U	FUNCTIONAL	M9164C1068/U		4	TRADE	HONEYWELL	
M934A1300/U	FUNCTIONAL	M9164D1009/U	WITH	1	TRADE	HONEYWELL	
M934A1318/U	FUNCTIONAL	M9164D1009/U	WITH	1	TRADE	HONEYWELL	
M934A1318/U	FUNCTIONAL	M9164C1068/U		4	TRADE	HONEYWELL	
M934A1326/U	FUNCTIONAL	M9164D1009/U	WITH	1	TRADE	HONEYWELL	
M934A1326/U	FUNCTIONAL	M9164A1005/U		3	TRADE	HONEYWELL	
M934A1334/U	FUNCTIONAL	M9164D1009/U		1	TRADE	HONEYWELL	
M934A1342/U	FUNCTIONAL	M9164D1009/U	OR	1	TRADE	HONEYWELL	
M934A1342/U	FUNCTIONAL	M9164A1005/U		2	TRADE	HONEYWELL	
M934A1367/U	FUNCTIONAL	M9164D1009/U	WITH	1	TRADE	HONEYWELL	
M934A1490/U	FUNCTIONAL	M9164D1009/U	WITH	1	TRADE	HONEYWELL	
M934A1599/U	FUNCTIONAL	M9164D1009/U	WITH	1	TRADE	HONEYWELL	
M934D1000/U	DIRECT	M9174D1007/U	WITH	1	TRADE	HONEYWELL	
M934D1000/U	FUNCTIONAL	M9174B1043/U		4	TRADE	HONEYWELL	
M934D1018/U	FUNCTIONAL	M9174D1007/U	WITH	1	TRADE	HONEYWELL	
M934D1018/U	FUNCTIONAL	M9174C1033/u		4	TRADE	HONEYWELL	
M934D1026/U	FUNCTIONAL	M9174D1007/U	WITH	1	TRADE	HONEYWELL	
M934D1026/U	FUNCTIONAL	M9174B1027/u		4	TRADE	HONEYWELL	
M934D1034/U	FUNCTIONAL	M9174D1007/U	WITH	1	TRADE	HONEYWELL	
M934D1034/U	FUNCTIONAL	M9174C1025/		4	TRADE	HONEYWELL	
M941A1008/U	FUNCTIONAL	M9484D1010/U		1	TRADE	HONEYWELL	
M941A1016/U	FUNCTIONAL	M9484D1010/U		1	TRADE	HONEYWELL	

Modutrol IV Motor Cross Reference

ITEM NUMBER	REPL TYPE	REPL ITEM	MULTI REPL	REPL SEQ	CHANNEL (BUSI GROUP)	MFG NAME	CUSTOMER REMARKS
M941A1024/U	FUNCTIONAL	M9484D1010/U		1	TRADE	HONEYWELL	
M941A1032/U	FUNCTIONAL	M9484D1010/U		1	TRADE	HONEYWELL	
M941A1057/U	FUNCTIONAL	M9484D1010/U		1	TRADE	HONEYWELL	
M941B1007/U	FUNCTIONAL	M6284F1013/U		2	TRADE	HONEYWELL	
M941C1006/U	FUNCTIONAL	M9484E1009/U		1	TRADE	HONEYWELL	
M941C1014/U	FUNCTIONAL	M9484E1017/U		1	TRADE	HONEYWELL	
M941C1022/U	FUNCTIONAL	M9484E1033/U		1	TRADE	HONEYWELL	
M941C1030/U	FUNCTIONAL	M9484E1033/U		1	TRADE	HONEYWELL	
M941C1063/U	FUNCTIONAL	M9484E1033		1	TRADE	HONEYWELL	
M941D1005/U	FUNCTIONAL	M9484F1007/U		1	TRADE	HONEYWELL	
M941D1021/U	FUNCTIONAL	M9484F1023/U		1	TRADE	HONEYWELL	
M941D1039/U	FUNCTIONAL	M9484F1031/U		1	TRADE	HONEYWELL	
M941D1047/U	FUNCTIONAL	M9484F1049/U		1	TRADE	HONEYWELL	
M944A1002/U	DIRECT	M9184D1021/U		2	ALL	HONEYWELL	
M944A1010/U	FUNCTIONAL	M9184D1021/U	OR	1	TRADE	HONEYWELL	
M944A1010/U	FUNCTIONAL	M9184A1019/U		2	TRADE	HONEYWELL	
M944A1028/U	FUNCTIONAL	M9184D1021/U	OR	1	TRADE	HONEYWELL	
M944A1028/U	FUNCTIONAL	M9184A1019/U		2	TRADE	HONEYWELL	
M944B1167/U	FUNCTIONAL	M6284D1000/U		1	TRADE	HONEYWELL	
M944B1175/U	FUNCTIONAL	M6284D1000/U		1	TRADE	HONEYWELL	
M944B1183/U	DIRECT	M6284D1000/U		1	TRADE	HONEYWELL	
M944C1000/U	FUNCTIONAL	M9184D1021/U	OR	1	TRADE	HONEYWELL	
M944C1000/U	FUNCTIONAL	M9184D1005/U		2	TRADE	HONEYWELL	
M944C1018/U	FUNCTIONAL	M9194D1003/U		1	TRADE	HONEYWELL	
M944C1042/U	FUNCTIONAL	M9184D1021/U	OR	1	TRADE	HONEYWELL	
M944D1017/U	FUNCTIONAL	M9184D1021/U	WITH	1	TRADE	HONEYWELL	
M944D1017/U	FUNCTIONAL	M9184F1034/U		3	TRADE	HONEYWELL	
M944E1040/U	FUNCTIONAL	M6284D1000-S/U	WITH	1	TRADE	HONEYWELL	
M944E1040/U	FUNCTIONAL	M6284F1013-S/U		3	TRADE	HONEYWELL	
M944G1089/U	FUNCTIONAL	M6284D1000/U	WITH	1	TRADE	HONEYWELL	
M944G1097/U	FUNCTIONAL	M6284D1000/U	WITH	1	TRADE	HONEYWELL	
M944J1051/U	FUNCTIONAL	M6284D1000/U		1	TRADE	HONEYWELL	
M944S1027/U	FUNCTIONAL	M6284D1000/U	WITH	1	TRADE	HONEYWELL	
M945A1009/U	FUNCTIONAL	M9185D1004/U	OR	1	TRADE	HONEYWELL	
M945A1009/U	FUNCTIONAL	M9185A1018/U		2	TRADE	HONEYWELL	
M945A1017/U	FUNCTIONAL	M9185D1004/U	OR	1	TRADE	HONEYWELL	
M945A1017/U	FUNCTIONAL	M9185A1018/U		2	TRADE	HONEYWELL	
M945A1033/U	FUNCTIONAL	M9185D1004/U	OR	1	TRADE	HONEYWELL	
M945A1033/U	FUNCTIONAL	M9185A1018/U		2	TRADE	HONEYWELL	
M945A1082/U	FUNCTIONAL	M9185D1004/U	OR	1	TRADE	HONEYWELL	
M945A1082/U	FUNCTIONAL	M9185A1018/U		2	TRADE	HONEYWELL	
M945A1157/U	FUNCTIONAL	M9185D1004/U		1	TRADE	HONEYWELL	
M945B1057/U	FUNCTIONAL	M6285A1005/U		1	TRADE	HONEYWELL	
M945B1065/U	FUNCTIONAL	M6285A1005/U		1	TRADE	HONEYWELL	
M945B1115/U	FUNCTIONAL	M6285A1005/U	WITH	1	TRADE	HONEYWELL	
M945C1015/U	FUNCTIONAL	M6285A1005/U	WITH	1	TRADE	HONEYWELL	
M945C1015/U	FUNCTIONAL	M6285C1001/U		3	TRADE	HONEYWELL	
M945D1006/U	FUNCTIONAL	M9185D1004/U	WITH	1	TRADE	HONEYWELL	
M945D1006/U	FUNCTIONAL	M9185C1006/U		3	TRADE	HONEYWELL	
M945F1004/U	FUNCTIONAL	M9185D1004/U	OR	1	TRADE	HONEYWELL	
M945F1004/U	FUNCTIONAL	M9185A1018/U		2	TRADE	HONEYWELL	
M945G1037/U	FUNCTIONAL	M6285A1005/U	OR	1	TRADE	HONEYWELL	
M945G1037/U	FUNCTIONAL	M6285A1005/U		2	TRADE	HONEYWELL	
M945J1025/U	FUNCTIONAL	M9185D1004/U	WITH	1	TRADE	HONEYWELL	
M945J1025/U	FUNCTIONAL	M9185C1006/U		3	TRADE	HONEYWELL	
M945M1006/U	FUNCTIONAL	M9185D1004/U	OR	1	TRADE	HONEYWELL	
M945M1006/U	FUNCTIONAL	M9185A1018/U		2	TRADE	HONEYWELL	
M9481D1005/U	DIRECT	M9484F1007/U		1	TRADE		
M9481D1005/U	FUNCTIONAL	M9484D1010			TRADE	HONEYWELL	
M9481E1002/U	DIRECT	M9484F1007/U		1	ALL	HONEYWELL	
M9481E1002/U	FUNCTIONAL	M9484E1017/U		2	ALL	HONEYWELL	
M9481F1000/U	DIRECT	M9484F1007/U		1	ALL		
M9484D1002/U	FUNCTIONAL	M9484D1010/U		1	ALL	HONEYWELL	
M9484D1028/U	FUNCTIONAL	M9484D1010/U		1	ALL	HONEYWELL	
M9484D1036/U	FUNCTIONAL	M9484E1009/U		1	ALL	HONEYWELL	
M9484E1058/U	FUNCTIONAL	M9484E1033/U		1	ALL	HONEYWELL	
M954A1035/U	FUNCTIONAL	M9184D1021/U		1	TRADE	HONEYWELL	
M954B1034/U	FUNCTIONAL	M9184D1021/U	WITH	1	TRADE	HONEYWELL	
M954C1066/U	FUNCTIONAL	M9184D1021/U	WITH	1	TRADE	HONEYWELL	
M954C1074/U	FUNCTIONAL	M9184D1021/U	WITH	1	TRADE	HONEYWELL	
M954D1016/U	FUNCTIONAL	M9184D1021/U	WITH	1	TRADE	HONEYWELL	
M955A1024/U	FUNCTIONAL	M9185D1004/U		1	TRADE	HONEYWELL	
M955C1014/U	FUNCTIONAL	M9185D1004/U	WITH	1	TRADE	HONEYWELL	

CROSS REFERENCE

Modutrol IV Motor Cross Reference

ITEM NUMBER	REPL TYPE	REPL ITEM	MULTI REPL	REPL SEQ	CHANNEL (BUSI GROUP)	MFG NAME	CUSTOMER REMARKS
M955C4000/U	FUNCTIONAL	M9185D1004/U	WITH	1	TRADE	HONEYWELL	
M955D1005/U	FUNCTIONAL	M9185D1004/U	OR	1	TRADE	HONEYWELL	
M965A1007/U	FUNCTIONAL	M9185D1004/U		1	TRADE	HONEYWELL	
M975A1006/U	FUNCTIONAL	M9185D1004/U		1	TRADE	HONEYWELL	
M975A1089/U	FUNCTIONAL	M9185D1004/U		1	TRADE	HONEYWELL	
M975A1097/U	FUNCTIONAL	M9185D1004/U	WITH	1	TRADE	HONEYWELL	
M975A1097/U	DIRECT	M9185D1004/U		3	TRADE	HONEYWELL	
M975B1021/U	FUNCTIONAL	M9185D1004/U	WITH	1	TRADE	HONEYWELL	
MA-12313	FUNCTIONAL	M8415A1004/U		1	TRADE	BARBER COLMAN	
MA-12323	FUNCTIONAL	M8415A1004/U		1	TRADE	BARBER COLMAN	
MA-305	FUNCTIONAL	M836A1042/U		1	TRADE	BARBER COLMAN	
MA-305-500	FUNCTIONAL	M836A1042/U		1	TRADE	BARBER COLMAN	
MA-308	FUNCTIONAL	M845A1027/U		1	TRADE	BARBER COLMAN	
MA-318	FUNCTIONAL	M8185D1006/U	OR	1	TRADE	BARBER COLMAN	
MA-318	FUNCTIONAL	M8185D1006/U		2	TRADE	BARBER COLMAN	
MA-318-500	FUNCTIONAL	M8185D1006/u	WITH		ALL	BARBER COLMAN	TRADE LINE IS 60 SECOND TIMING 160 DEG STROKE SETTING
MA-405	FUNCTIONAL	M436A1116/U		1	TRADE	BARBER COLMAN	
MA-405-500	FUNCTIONAL	M436A1116/U		1	TRADE	BARBER COLMAN	
MA-406	FUNCTIONAL	M836A1042/U		1	TRADE	BARBER COLMAN	
MA-406-500	FUNCTIONAL	M836A1042/U		1	TRADE	BARBER COLMAN	
MA-407	FUNCTIONAL	M436A1124/U		1	TRADE	BARBER COLMAN	
MA-407-500	FUNCTIONAL	M436A1124/U		1	TRADE	BARBER COLMAN	
MA-416	DIRECT	M8185D1006/U	WITH	1	TRADE	BARBER COLMAN	
MA-416	DIRECT	M4185B1058/U	WITH	3	TRADE	BARBER COLMAN	
MA-416-500	DIRECT	M8185D1006/U	WITH	1	TRADE	BARBER COLMAN	
MA-416-500	DIRECT	M4185B1058/U		4	TRADE	BARBER COLMAN	
MA-418	DIRECT	M8185D1006/U	WITH	1	TRADE	BARBER COLMAN	
MA-418	DIRECT	M4185A1001/U		3	TRADE	BARBER COLMAN	
MA-418-500	DIRECT	M8185D1006/U	WITH	1	TRADE	BARBER COLMAN	
MA-418-500	DIRECT	M4185B1009/U		4	TRADE	BARBER COLMAN	
MA-419	DIRECT	M8185D1006/U	WITH	1	TRADE	BARBER COLMAN	
MA-419	FUNCTIONAL	M4185B1058/U	WITH	3	TRADE	BARBER COLMAN	
MA-419-500	DIRECT	M8185D1006/U	WITH	1	TRADE	BARBER COLMAN	
MA-419-500	DIRECT	M4185B1058/U	WITH	4	TRADE	BARBER COLMAN	
MA5213	FUNCTIONAL	M6410A1011/U		1	TRADE	BARBER COLMAN	
MA5-419	FUNCTIONAL	M8185D1006/U	WITH	1	TRADE	BARBER COLMAN	
MA5-419	FUNCTIONAL	M4185B1058/U	WITH	3	TRADE	BARBER COLMAN	
MA5-419-500	FUNCTIONAL	M8185D1006/U	WITH	1	TRADE	BARBER COLMAN	
MA5-419-500	FUNCTIONAL	M4185B1058/U		4	TRADE	BARBER COLMAN	
MC-351	FUNCTIONAL	M6194D1017/U	WITH	1	TRADE	BARBER COLMAN	
MC-421	FUNCTIONAL	M6184D1035/U	WITH	1	TRADE	BARBER COLMAN	
MC-431	FUNCTIONAL	M6194D1017/U	WITH	1	TRADE	BARBER COLMAN	
MC-4311	FUNCTIONAL	M6194D1017/U	WITH	1	TRADE	BARBER COLMAN	
MC5-4311	FUNCTIONAL	M6194D1017/U	WITH	1	TRADE	BARBER COLMAN	
ME-12313	FUNCTIONAL	M8405A1006/U		1	TRADE	BARBER COLMAN	
ME-12313-102	FUNCTIONAL	M8405A1006/U		1	TRADE	BARBER COLMAN	
MP-2113-500	FUNCTIONAL	M6184D1035/U	WITH	1	TRADE	BARBER COLMAN	
MP-2113-500	FUNCTIONAL	M6184D1001/U		3	TRADE	BARBER COLMAN	
MP-2130-500	FUNCTIONAL	M6184D1035/U	WITH	1	TRADE	BARBER COLMAN	
MP-2130-500	FUNCTIONAL	M6184D1001/U		4	TRADE	BARBER COLMAN	
MP-2150-500	FUNCTIONAL	M6184D1035/U	WITH	1	TRADE	BARBER COLMAN	
MP-2150-500	FUNCTIONAL	M6184A1023/U		4	TRADE	BARBER COLMAN	
MP-2151-500	FUNCTIONAL	M6184D1035/U	WITH	1	TRADE	BARBER COLMAN	
MP-371	FUNCTIONAL	M6294D1008/U	WITH	1	TRADE	BARBER COLMAN	
MP-381	FUNCTIONAL	M6194D1017/U	WITH	1	TRADE	BARBER COLMAN	
MP-481	FUNCTIONAL	M9194D1003/U	WITH	1	TRADE	BARBER COLMAN	
MP-483-600	FUNCTIONAL	M6294D1008/U	WITH	1	TRADE	BARBER COLMAN	
MP-483-600	FUNCTIONAL	M6294D1008/U		4	TRADE	BARBER COLMAN	
MP-485	FUNCTIONAL	M6194D1017/U	WITH	1	TRADE	BARBER COLMAN	
MP-4851	FUNCTIONAL	M6294D1008/U	WITH	1	TRADE	BARBER COLMAN	
MP-486	FUNCTIONAL	M6294D1008/U	WITH	1	TRADE	BARBER COLMAN	
MP5213	FUNCTIONAL	M7410E1010/U	OR	1	TRADE	BARBER COLMAN	
MP5213	FUNCTIONAL	M7410E1036/U		2	TRADE	BARBER COLMAN	
MU-12313	FUNCTIONAL	M7415A1006/U		1	TRADE	BARBER COLMAN	
P-8-11066	FUNCTIONAL	M745G1007/U		1	TRADE	LENNOX	
P-8-11067	FUNCTIONAL	M734H1026/U		1	TRADE	LENNOX	
P-8-11208	FUNCTIONAL	M745K1002/U		1	TRADE	LENNOX	
P-8-8230	FUNCTIONAL	M954A1035/U		1	TRADE	LENNOX	
P-8-8271	FUNCTIONAL	M945A1017/U		1	TRADE	LENNOX	
P-8-8371	FUNCTIONAL	M945A1017/U		1	TRADE	LENNOX	
P-8-8701	FUNCTIONAL	M934A1235/U		1	TRADE	LENNOX	
SQS65	FUNCTIONAL	M7410E1010/U	OR	1	TRADE	POWERS/LANDIS & GYR	

Modutrol IV Motor Cross Reference

ITEM NUMBER	REPL TYPE	REPL ITEM	MULTI REPL	REPL SEQ	CHANNEL (BUSI GROUP)	MFG NAME	CUSTOMER REMARKS
SQS65	FUNCTIONAL	M7410E1036/U		2	TRADE	POWERS/LANDIS & GYR	
SQS82	FUNCTIONAL	M6410A1003/U	OR	1	TRADE	BARBER COLMAN	
SQS82	FUNCTIONAL	M6410A1011/U		2	TRADE	BARBER COLMAN	
SSC61U	FUNCTIONAL	M7410F1000/U		1	ALL	SIEMENS	
SSC81U	FUNCTIONAL	M6410A1029/U		1	ALL	SIEMENS	
V70DB-6	FUNCTIONAL	M945D1006/U		1	TRADE	JOHNSON CONTROLS	
VA-7450-10011	FUNCTIONAL	M6410A1029/U		1	ALL	JOHNSON CONTROLS	
VA-7452-90011	FUNCTIONAL	M7410F1000/U		1	ALL	JOHNSON CONTROLS	
VA8050-1	FUNCTIONAL	M6410A1003/U	OR	1	TRADE	JOHNSON CONTROLS	
VA8050-1	FUNCTIONAL	M6410A1011/U		2	TRADE	JOHNSON CONTROLS	
VA8050-1007	FUNCTIONAL	M6410A1003/U	OR	2	TRADE	JOHNSON CONTROLS	
VA8050-1007	FUNCTIONAL	M6410A1011/U		3	TRADE	JOHNSON CONTROLS	
VA8052-1	FUNCTIONAL	M7410E1010/U	OR	1	TRADE	JOHNSON CONTROLS	
VA8052-1	FUNCTIONAL	M7410E1036/U		2	TRADE	JOHNSON CONTROLS	
W6210A1003/U	FUNCTIONAL	M7215A1008/U		1	TRADE		
W7395A1008/P	DIRECT	M7215A1016/U		1	ALL		
W7415A1004/B	DIRECT	M7415A1006/U	WITH	1	ALL		
W899A1030/U	FUNCTIONAL	M9164D1009/U		3	TRADE		
W899G1000/U	DIRECT	M9185A1018/U		3	TRADE	HONEYWELL	
W899G1034/U	FUNCTIONAL	M9185A1018/U		3	TRADE	HONEYWELL	
W899G1042/U	FUNCTIONAL	M9185A1018/U	WITH	3	TRADE	HONEYWELL	

Section 8:

APPENDIX A:

Valve Selection & Sizing244

APPENDIX B:

NEMA Standard Classification Code for Enclosures263

APPENDIX C:

Best Practices for Low Power Control Signal Wiring264

Notes265

Warranty.....267

Appendix A: Valve Selection and Sizing

Introduction

This section provides information on valve selection and sizing. Valves must be selected for ability to meet temperature, pressure, flow control characteristic, and piping connection requirements of the hydronic system. Valve sizing is critical to ensure support for heating and cooling loads with adequate valve capacity, yet able to control system flow to provide stable building conditions efficiently.

Definitions

Valve Components

Actuator: The part of an automatic control valve that moves the stem based on an electric, electronic, or pneumatic signal from a controller. The actuator and valve can be two separate devices or together they can be one device.

Body: The valve casting through which the controlled fluid flows (Fig. 1).

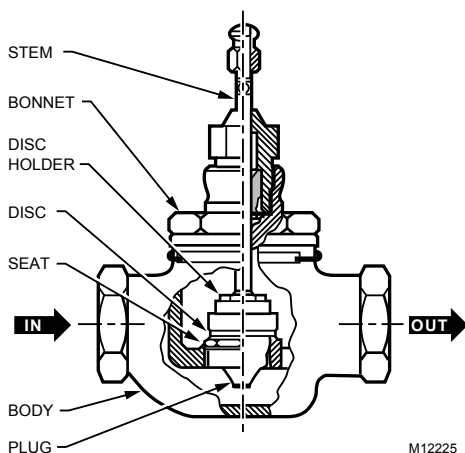

Fig. 1. Globe Valve Components.

Bonnet: The part that screws to the top of the valve body and contains the packing that seals and guides the valve stem.

Disc: The part of the valve assembly that contacts the valve seat to close off flow of the controlled fluid. Some valve assemblies are built so the disc is replaceable. Replaceable discs are usually made of a composition material softer than metal. "Metal trim" valves use precisely-machined metal plugs and seats operated by high force actuators instead of a disk.

Plug: The part that varies the opening for the fluid to flow through the valve body. The following describes the three most common types of plugs:

- A contoured plug has a shaped end that is usually end-guided at the top or bottom (or both) of the

valve body. The shaped end controls fluid flow through the valve with respect to stem travel.

- A V-port plug has a cylinder, called a skirt, that rides up and down in the valve seat ring. The skirt guides the plug and varies the flow area with respect to stem travel via its shaped openings.
- A quick-opening plug is flat and is either end-guided or guided by wings riding in the valve seat ring. The flat plug provides maximum flow soon after it lifts from the valve seat.

Port: The opening in the valve seat.

Seat: The stationary part of the valve body that has a raised lip to contact the valve disc when closing off flow of the controlled fluid.

Stem: The shaft that runs through the valve bonnet and connects an actuator to the valve plug.

Trim: All parts of the valve that contact the controlled fluid. Trim includes the stem, packing, plug, disc, and seat; it does not include the valve body.

Valve Flow Characteristics

Direction of Flow: The correct flow of the controlled fluid through the valve is usually indicated on the valve body. If the fluid flow through the valve is incorrect, the disc can slam into the seat as it approaches the closed position. The result is poor control, excessive valve wear, and noisy operation. In addition, the actuator must work harder to reopen the closed valve since it must overcome the pressure exerted by the fluid on top of the disc rather than have the fluid assist in opening the valve by exerting pressure under the disc. Gate and butterfly valves may offer bi-directional flow.

Equal percentage: A valve which changes flow by an equal percentage (regardless of flow rate) for similar movements in stem travel (at any point in the flow range).

Linear: A valve which provides a flow-to-lift relationship that is directly proportional. It provides equal flow changes for equal lift changes, regardless of percentage of valve opening.

Quick-opening: A valve which provides maximum possible flow as soon as the stem lifts the disc from the valve seat.

Valve flow characteristic: The relationship between the stem travel of a valve, expressed in percent of travel, and the fluid flow through the valve, expressed in percent of full flow.

Appendix A: Valve Selection and Sizing

Valve Flow Terms

Rangeability: The ratio of maximum flow to minimum controllable flow. Approximate rangeability ratios are 50 to 1 for V-port globe valves and 30 to 1 for contoured plug valves.

EXAMPLE:

A valve with a total flow capacity of 100 gpm full open and a rangeability of 30 to 1, can accurately controls flow accurately as low as 3 gpm.

Tight shut-off/close-off: A valve condition in which virtually no leakage of the controlled fluid occurs in the closed position. Generally, only single-seated valves provide tight shut-off. Double-seated valves typically have a one to three percent leakage in the closed position.

Turndown: The ratio of maximum flow to minimum controllable flow of a valve installed in a system. Turndown is equal to or less than rangeability.

EXAMPLE:

For the valve in the rangeability example, if the system requires a 66 gpm maximum flow through the valve and since the minimum accurately controllable flow is 3 gpm, the turndown is 22.

Valve Ratings

Flow coefficient (capacity index): Used to state the flow capacity of a control valve for specified conditions. In the control valve industry currently one of three flow coefficients is used depending upon the location and system of units; British A_v , European k_{vs} , or United States C_v . The flow coefficients have the following relationships:

$$\begin{aligned}A_v &= 0.0000278 k_{vs} \\A_v &= 0.0000240 C_v \\k_{vs} &= 0.865 C_v\end{aligned}$$

The flow coefficient A_v is in cubic meters per second and can be determined from the formula:

$$A_v = Q \sqrt{\frac{\rho}{\Delta p}}$$

Where:

- Q = volumetric flow in cubic meters per second.
- ρ = fluid density in kilograms per cubic meter.
- Δp = static pressure loss across the valve in pascals.

The flow coefficient k_{vs} is water flow in cubic meters per hour with a static pressure loss across the valve of

10⁵ pascals (1 bar) within the temperature range of 5 to 40°C and can be determined from the formula:

$$k_{vs} = Q \sqrt{\frac{\Delta p k_{vs}}{\Delta p} \cdot \frac{\rho}{\rho_w}}$$

Where:

- Q = volumetric flow in cubic meters per hour.
- ρ = fluid density in kilograms per cubic meter.
- ρ_w = density of water in kilograms per cubic meter.
- $\Delta p k_{vs}$ = static pressure loss of 10⁵ pascals.
- Δp = static pressure loss across the valve in pascals.

The flow coefficient C_v is water flow in gallons per minute with a pressure loss across the valve of one pound per square inch within the temperature range of 40 to 100F and can be determined for other conditions from the formula:

$$C_v = Q \sqrt{\frac{1}{\Delta p} \cdot \frac{\rho}{\rho_w}}$$

Where:

- Q = volumetric flow in US gallons per minute.
- ρ = fluid density in pounds per cubic foot.
- ρ_w = density of water in pounds per cubic foot within the temperature range of 40 to 100F
- Δp = static pressure loss across the valve in pounds per square inch.

Close-off rating: The maximum pressure drop that a valve can withstand without leakage while in the full closed position. The close-off rating is a function of actuator power to hold the valve closed against pressure drop, by structural parts such as the stem can be the limiting factor. The construction of gate-style valves, such as ball valves, often allows them to hold back high head pressures in the closed position, although the actuator may not be powerful enough to operate the valve against such forces.

EXAMPLE:

A valve with a close-off rating of 10 psi could have 40 psi upstream pressure and 30 psi downstream pressure. Note that in applications where failure of the valve to close is hazardous, the maximum upstream pressure must not exceed the valve close-off rating, regardless of the downstream pressure.

The valve close-off rating is independent of the actual valve body rating. See definition of BODY RATING (ACTUAL).

Appendix A: Valve Selection and Sizing

Close-off rating of three-way valves: The maximum pressure difference between either of the two inlet ports and the outlet port for mixing valves, or the pressure difference between the inlet port and either of the two outlet ports for diverting valves.

Pressure drop: The difference in upstream and downstream pressures of the fluid flowing through the valve.

Pressure drop (critical): The flow of a gaseous controlled fluid through the valve increases as the pressures drop increases until reaching a critical point. This is the critical pressure drop.

Any increase in pressure drop beyond the critical pressure drop is dissipated as noise and cavitation rather than increasing flow. The noise and cavitation can destroy the valve and adjacent piping components.

Body rating (nominal): The theoretical pressure rating, expressed in psi, of the valve body exclusive of packing, disc, etc. The nominal rating is often cast on the valve body and provides a way to classify the valve by pressure. A valve of specified body material and nominal body rating often has characteristics such as pressure-temperature ratings, wall thickness, and end connections which are determined by a society such as ANSI (American National Standards Institute). Figure 2 shows ANSI pressure-temperature ratings for valves. Note that the nominal body rating is not the same as the actual body rating.

Body rating (actual): The correlation between safe, permissible flowing fluid pressure and flowing fluid temperature of the valve body (exclusive of the packing, disc, etc.). The nominal valve body rating is the permissible pressure at a specific temperature.

EXAMPLE:

From Figure 2, a valve with an ANSI rating of 150 psi (ANSI Class 150) has an actual rating of 225 psi at 250F.

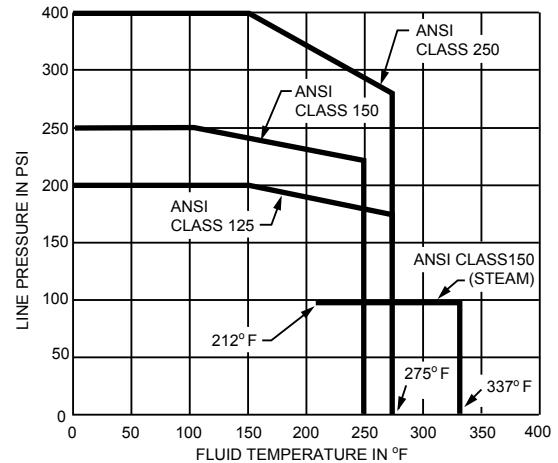

NOTES:

1. FOR HIGH FLUID TEMPERATURES, THE VALVE AND/OR PIPING SHOULD BE INSULATED TO PREVENT AMBIENT TEMPERATURES FROM EXCEEDING ACTUATOR RATINGS.

M12224

Fig. 2. Sample ANSI Pressure-Temperature Ratings for Valves.

Maximum pressure and temperature: The maximum pressure and temperature limitations of fluid flow that a valve can withstand. These ratings may be due to valve packing, body, or disc material or actuator limitations. The actual valve body ratings are exclusively for the valve body and the maximum pressure and temperature ratings are for the complete valve (body and trim). Note that the maximum pressure and temperature ratings may be less than the actual valve body ratings.

EXAMPLE:

The body of a valve, exclusive of packing, disc, etc., has a pressure and temperature rating of 125 psi at 335F. If the valve contains a composition disc that can withstand a temperature of only 240F, then the temperature limit of the disc becomes the maximum temperature rating for the valve.

Valve Types

Ball valve: A ball valve has a precision ball between two seats with a body (Fig. 3). Ball valves have several port sizes for a given body size and go from closed to open with a 90 degree turn of the stem. They are available in both two-way and three-way configurations. For HVAC applications, ball valve construction includes brass and cast iron bodies; stainless steel, chrome plated brass, and cast iron balls; resilient seats with various temperature ratings. Ball valves provide tight shut-off, while full port models have low flow resistance, and models with flow characterizing inserts can be selected for modulating applications.

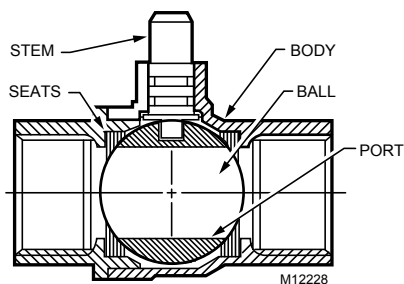

Fig. 3. Ball Valve.

Butterfly valve: A valve with cylindrical body, a shaft, and a rotating disc (Fig. 4). The disc rotates 90 degrees from open to closed. The disc seats against a resilient body liner or spring-loaded metal seat and may be manufactured for tight shut-off or made smaller for reduced operating torque at lower close-off. Butterfly valves have limited rangeability for modulating applications so are used mainly for two-way operation. For three-way applications, two butterfly valves are assembled to a pipe tee with linkage for simultaneous operation.

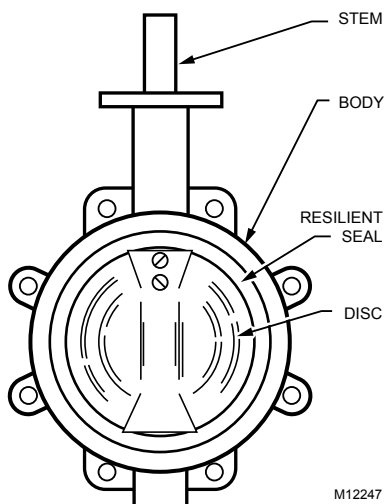

Fig. 4. Butterfly Valve.

Double-seated valve: A valve with two seats, plugs, and discs.

Double-seated valves are suitable for applications where fluid pressure is too high to permit a single seated valve to close. The discs in a double-seated valve are arranged so that in the closed position there is minimal fluid pressure forcing the stem toward the open or closed position; the pressure on the discs is essentially balanced. For a valve of given size and port area, the double-seated valve requires less force to operate than the single-seated valve so the double seated valve can use a smaller actuator than a single seated.

Also, double-seated valves often have a larger port area for a given pipe size. A limitation of double-seated valves is that they do not provide tight shut-off. Since both discs rigidly connect together and changes in fluid temperature can cause either the disc or the valve body to expand or contract, one disc may seat before the other and prevent the other disc from seating tightly.

Flanged-end connections: A valve that connects to a pipe by bolting a flange on the valve to a flange screwed onto the pipe. Flanged connections are typically used on large valves only.

Gate valve: A valve that controls flow using a gating mechanism, usually a plate, that moves across the valve seat instead of pushing against the flow. The actuator works against the friction of the seals rather than directly against the force of the water. Gate valves are inherently self-sealing and are often capable of high close-off pressures without an actuator. Ball valves are a type of gate valve.

Globe valve: A valve which controls flow by moving a circular disk against or away from a seat. When used in throttling control a contoured plug (throttling plug) extends from the center of circular disk through the center of the seat for precise control (Fig. 1).

Pressure-balanced valve: A globe valve with a sealed pressure chamber built into the plug, which equalizes head pressure across the seat and allows most of the actuator force to be used to close off the flow, resulting in very high close-off ratings with very low seat leakage.

Reduced-port valve: A valve with a capacity less than the maximum for the valve body. Ball, butterfly, and smaller globe valves are available with reduced ports to allow correct sizing for good control.

Appendix A: Valve Selection and Sizing

Single-seated valve: A valve with one seat, plug, and disc. Single-seated valves are suitable for applications requiring tight shut-off. Since a single-seated valve has nothing to balance the force of the fluid pressure exerted on the plug, it requires more closing force than a double-seated valve of the same size and therefore requires more actuator force than a double-seated valve.

Threaded-end connection: A valve with threaded pipe connections. Valve threads are usually tapered female, to National Pipe Thread standards, but male connections are available for special applications. Some valves have an integral union for easier installation.

Three-way valve: A valve with three ports. The internal design of a three-way valve classifies it as a mixing or diverting valve. Three-way valves control liquid in modulating or two-position applications and do not provide tight shut-off.

Two-way valve: A valve with one inlet port and one outlet port. Two-way valves control water or steam in two-position or modulating applications and provide tight shut-off in both straight through and angle patterns.

Valve Material and Media

Valves with bronze or cast iron bodies having brass or stainless steel trim perform satisfactorily in HVAC hydronic systems when the water is treated properly. Failure of valves in these systems may be an indication of inadequate water treatment. The untreated water may contain dissolved minerals (e.g., calcium, magnesium, or iron compounds) or gases (e.g., carbon dioxide, oxygen, or ammonia). Inadequate treatment results in corrosion of the system. Depending on the material of the valve, the color of the corrosion may indicate the substance causing the failure (Table 1).

Table 1. Corrosive Elements in Hydronic Systems.

Brass or Bronze Component	
Corrosive Substance	Corrosion Color
Chloride	Light Blue-Green
Ammonia	Blue or Dark Blue
Carbonates	Dark Blue-Green
Magnesium or Calcium	White
Oxides	Black (water)
Sulphide (Hydrogen)	Black (Gas)
Iron	Rust
Iron or Steel Component	
Corrosive Substance	Corrosion Color
Magnesium or Calcium	White
Iron	Rust

Petroleum products from sources such as cutting oils, solder flux, etc. can cause some rubber compounds to swell and interfere with moving parts.

Chloramines, chemical compounds of ammonia and chlorine used to treat municipal drinking water, are reported to attack some rubber compounds commonly used in closed loop hydronic systems.

Particulate present in the system can interfere with, and sometimes damage moving parts. Examples include: rust (Fe_2O_3), magnetite (Fe_3O_4), sand (quartz granules), silt from municipal water, iron filings from pipe threads, and scale precipitated from hard water. Rust, in particular, is highly abrasive and can rapidly wear out stem seals, causing leaks.

To prevent damage to valves and pumps, a complete flushing of the system during commissioning, including the existing structure when building an addition, may be required to remove physical particulate. Additional components may also be needed, such as in-line Y-strainers for large objects such as stones or solder blobs and mechanical filtration, such as a 50 micron 10% side-stream filter piped in parallel with the system pumps.

Glycol solutions may be used to prevent hydronic systems freezing. Glycol solutions should be formulated for HVAC systems. Some available glycol solutions formulated for other uses contain additives that are injurious to some system seals. In addition, hydronic seals react differently to water and glycol such that when a new system is started up with water or glycol the seals are effective. The hydronic seals are likely to leak if the system is later restarted with media changed from water to glycol or glycol to water. To prevent leakage part of the process of media changeover should include replacing seals such as, pump and valve packing. Glycol mixtures are usually limited to 50% concentration. At 60% concentration, glycol mixtures have their minimum freezing temperature, but can have unstable phase changes which may severely damage a system.

Valve Selection

Proper valve selection matches a valve to the control and hydronic system physical requirements. First consider the application requirements and then consider the valve characteristics necessary to meet those requirements. The following questions provide a guide to correct valve selection.

- What is the piping arrangement and size?

The piping arrangement indicates whether a two-way or three-way mixing or diverting valve is needed. The piping size gives some indication of whether the valve requires a screwed end or a flanged end connection.

- Does the application require two-position control or proportional control? Does the application require a normally open or normally closed valve? Should the actuator be direct acting or reverse acting?

In its state of rest, the valve is normally open or closed depending on the load being controlled, the fluid being controlled, and the system configuration.

For chilled water coils, it is usually preferable to close the valve on fan shutdown to prevent excessive condensation around the duct and coil, and to save pumping energy. This may be accomplished with either normally closed valves or a variety of other control schemes. Lower cost and more powerful normally open valve assemblies may be used with the close-on-shutdown feature and allow, in the case of pneumatic systems, the capability to provide heating or cooling in the event of air compressor failure.

Converter control valves should be normally closed and outdoor air preheat valves should be normally open.

- Is tight shut-off necessary? What differential pressure does the valve have to close against? How much actuator close-off force is required?

Valves should never be allowed to "dead head" a pump unless the pumps are controlled by variable speed drive systems capable of detecting such conditions and shutting down the pumps.

Single-seated valves provide tight shut-off, while double-seated valves do not. Double seated valves are acceptable for use in pressure bypass or in-line throttling applications.

The design and flow capacity of a valve determine how much actuator force is required for a given close-off. Therefore, the valve must first be sized, then, the valve and actuator selected to provide the required close-off.

- What type of medium is being controlled? What are the temperature and pressure ranges of the medium?

Valves must be compatible with system media composition, maximum and minimum temperature, and maximum pressure. The temperature and pressure of the medium being controlled should not exceed the maximum temperature and pressure ratings of the valve.

For applications such as chlorinated water or brine, select valve materials to avoid corrosion.

- What is the pressure drop across the valve? Is the pressure drop high enough?

The full open pressure drop across the valve must be high enough to allow the valve to exercise control over its portion of the hydronic system. However, the full open pressure drop must not exceed the valve's rating for quiet service and normal life. Closed pressure drop must not exceed valve and actuator close-off rating.

Globe Valve

Globe valves are popular for HVAC applications. They are available in pipe sizes from 1/2 in. to 12 in. and in a large variety of capacities, flow characteristics, and temperature and pressure capabilities. They provide wide rangeability and tight shutoff for excellent control over a broad range of conditions. Globe valves are made in two-way, straight or angle configurations and three-way mixing and diverting designs. Globe valves close against the flow and have arrows on the body indicating correct flow direction. Incorrect piping can result in stem oscillations, noise, and high wear.

A two-way globe valve has one inlet port and one outlet port (Fig. 5) in either a straight through or angle pattern. The valve can be either push-down-to-close or push-down-to-open.

Pneumatic and electric actuators with linear motion to operate globe valves are available for operation with many control signals.

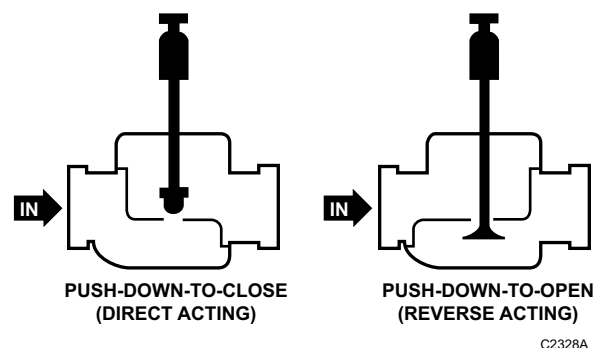

Fig. 5. Two-Way Globe Valves.

Appendix A: Valve Selection and Sizing

Ball Valve

Ball valves are available for two-position applications either manual (hand) or power operated or for modulating applications with direct coupled electric actuators. Ball valves are relatively low cost, provide tight close off, and are available in two-way and three-way configurations. As with all other valves, ball valves must be properly sized to provide good flow control.

When used in modulating service, ball valves must be specifically designed for modulating service as compared to two-position service. Packing must provide leak-free sealing through thousands of cycles to ensure trouble-free HVAC service. The ball, stem and seals should be made of materials that minimizes sticking and breakaway torque to achieve smooth operation.

Two-way ball valves have equal percentage flow control characteristics and flow in full-port models can be in either direction.

Three-way ball valves can be used in either mixing or diverting service. Full port models have linear flow control characteristics for constant total flow. A popular option with 3-way valves is a 20% flow capacity reduction in the B port to equalize pressure losses in a coil-bypass application.

Butterfly Valve

Butterfly valves (Fig. 6) control the flow of hot, chilled, or condenser water in two-position or proportional applications. Butterfly valves are available in two-way or three-way configurations. Tight shutoff may be achieved by proper selection of actuator force and body lining. The three-way valve can be used in mixing or diverting applications with the flow in any direction. The three-way valve consists of two butterfly valves that mount on a flanged cast iron tee and are linked to an actuator which opens one valve as it closes the other. Minimum combined capacity of both valves occurs at the half-open position.

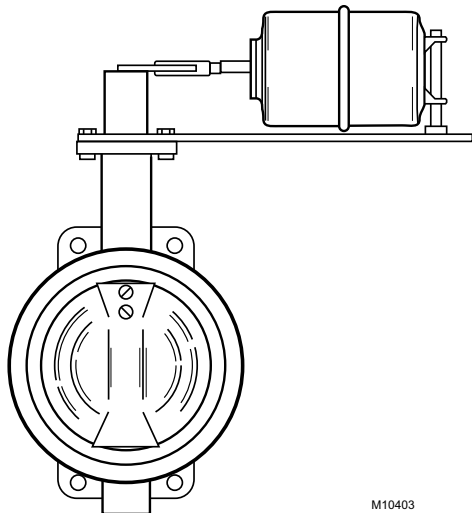

Fig. 6. Butterfly Valve.

When butterfly valves are used for proportional control, they must be applied using conservative pressure drop criteria. If the pressure drop approaches the critical pressure drop, unbalanced forces on the disc can cause oscillations, poor control, and/or damage to the linkage and actuator, even though the critical flow point is not reached. Modulating control is usually limited to a range of 15 to 65 degrees of disk rotation.

Butterfly valves are usually found in larger pipe sizes. For example, two butterfly valves could be piped in a mixing application to control the temperature of the water going back to the condenser. The valves proportion the amount of tower water and condenser water return that is flowing in the condenser water supply line.

Two-way Valve

Two-way valves are available as globe, ball, or butterfly valves. The combination of valve body and actuator (called valve assembly) determines the valve stem position. Two-way valves control steam or water in two-position or proportional applications (Fig. 7). They provide tight shutoff and are available with quick-opening, linear, or equal percentage flow characteristics. Control valves are typically installed on the supply side of convectors and radiators, and the return side of small-bore water coils used in fan-forced equipment.

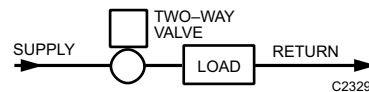

Fig. 7. Two-Way Valve Application.

Ideally, a control system has a linear response over its entire operating range. The sensitivity of the control to a change in temperature is then constant throughout the entire control range. For example, a small increase in temperature provides a small increase in cooling. A nonlinear system has varying sensitivity. For example, a small increase in temperature can provide a large increase in cooling in one part of the operating range and a small increase in another part of the operating range. To achieve linear control, the combined system performance of the actuator, control valve, and load must be linear. If the system is linear, a linear control valve is appropriate (Fig. 8). If the system is not linear, a nonlinear control valve, such as an equal percentage valve, is appropriate to balance the system so that resultant performance is linear.

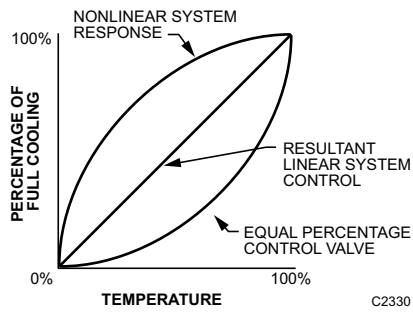

Fig. 8. Linear vs. Nonlinear System Control.

QUICK-OPENING VALVE

A quick-opening two-way valve includes only a disc guide and a flat or quick-opening plug. This type of valve is used for two position control of steam. The pressure drop for a quick opening two-way valve should be 10 to 20 percent of the piping system pressure differential, leaving the other 80 to 90 percent for the load and piping connections. Figure 9 shows the relationship of flow versus stem travel for a quick-opening valve. To achieve 90 percent flow, the stem must open only 20 percent. Linear or equal percentage valves can be used in lieu of quick-opening valves in two-position control applications as the only significant positions are full open and full closed.

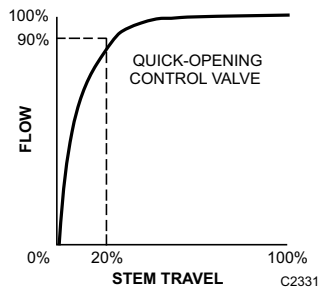

Fig. 9. Flow vs. Stem Travel Characteristic of a Quick-Opening Valve.

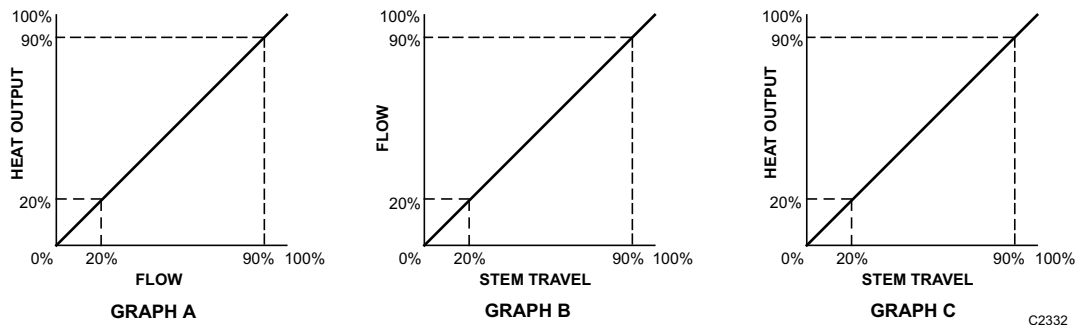

Fig. 10. Heat Output, Flow, and Stem Travel Characteristics of a Linear Valve.

EQUAL PERCENTAGE VALVE

An equal percentage valve includes a contoured plug or contoured V-port shaped so that similar movements in stem travel at any point in the flow range change the existing flow an

Linear Valve

A linear valve may include a V-port plug or a contoured plug. This type of valve is used for proportional control of steam or chilled water, or in applications that do not have wide load variations. Typically in steam or chilled water applications, changes in flow through the load (e.g., heat exchanger, coil) cause proportional changes in heat output. For example, Figure 10 shows the relationships between heat output, flow, and stem travel given a steam heat exchanger and a linear valve as follows:

- Graph A shows the linear relationship between heat output and flow for the steam heat exchanger. Changes in heat output vary directly with changes in the fluid flow.
- Graph B shows the linear relationship between flow and stem travel for the linear control valve. Changes in stem travel vary directly with changes in the fluid flow.

NOTE: As a linear valve just starts to open, a minimum flow occurs due to clearances required to prevent sticking of the valve. Some valves have a modified linear characteristic to reduce this minimum controllable flow. This modified characteristic is similar to an equal percentage valve characteristic for the first 5 to 10 percent of stem lift and then follows a linear valve characteristic for the remainder of the stem travel.

- Graph C shows the linear relationship between heat output and stem travel for the combined heat exchanger and linear valve. Changes in heat output are directly proportional to changes in the stem travel.

Thus a linear valve is used in linear applications to provide linear control.

equal percentage, regardless of flow rate. In mathematical terms, this is an exponential response.

Appendix A: Valve Selection and Sizing

EXAMPLE:

When a valve with the stem at 30 percent of its total lift and existing flow of 3.9 gpm (Table 2) opens an additional 10 percent of its full travel, the flow measures 6.2 gpm or increases 60 percent. If the valve opens an additional 10 percent so the stem is at 50 percent of its full travel, the flow increases another 60 percent and is 9.9 gpm.

Table 2. Stem Position vs. Flow for Equal Percentage Valve.

Stem		Flow	
Change	Position	Rate	Change
—	30% open	3.9 gpm	—
10% increase	40% open	6.2 gpm	60% increase
10% increase	50% open	9.9 gpm	60% increase

An equal percentage valve is used for proportional control in hot water applications and is useful in control applications where wide load variations can occur. Typically in hot water applications, large reductions in flow through the load (e.g., coil) cause small reductions in heat output. An equal percentage valve is used in these applications to achieve linear control. For example, Figure 11 shows the heat output, flow, and stem travel relationships for a hot water coil, with 200F, entering water and 50F entering air and an equal percentage valve, as follows:

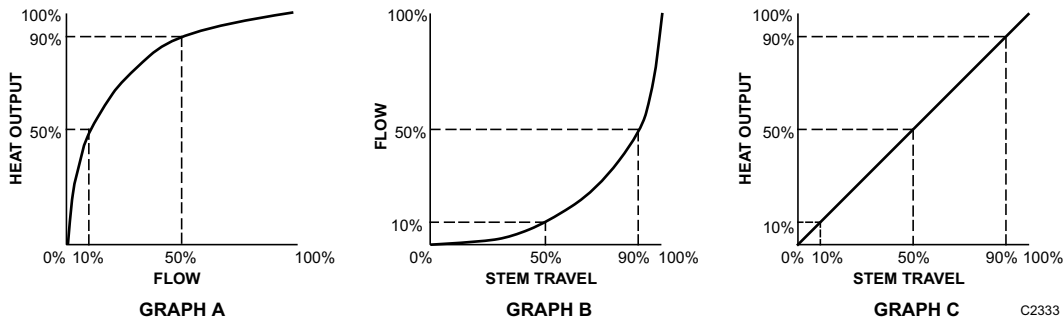

Fig. 11. Heat Output, Flow, and Stem Travel Characteristics of an Equal Percentage Valve.

Three-way Valves

Three-way valves (Fig. 12) control the flow of liquids in mixing or diverting valve applications (Fig. 13). The internal design of a three-way globe valve enables it to seat against the flow of liquid in the different applications. An arrow cast on the valve body indicates the proper direction of liquid flow. It is important to connect three-way valve piping correctly or oscillations, noise, and excessive valve wear can result. Three-way valves are typically have linear flow characteristics, although, some are equal percentage for flow through the coil with linear flow characteristics for flow through the coil bypass. Ball valves are also available in a three-way configuration, while two butterfly valves can be made to act as a three-way valve.

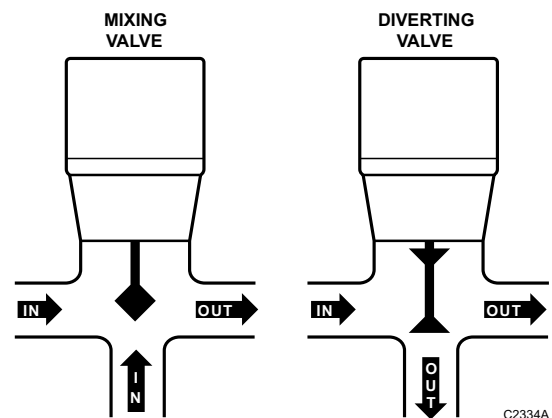

Fig. 12. Three-Way Valves.

- Graph A shows the nonlinear relationship between heat output and flow for the hot water coil. A 50 percent reduction in flow causes a 10 percent reduction in heat output. To reduce the heat output by 50 percent, the flow must decrease 90 percent.
- Graph B shows the nonlinear relationship between flow and stem travel for the equal percentage control valve. To reduce the flow 50 percent, the stem must close 10 percent. If the stem closes 50 percent, the flow reduces 90 percent.
- Graph C shows the relationship between heat output and stem travel for the combined coil and equal percentage valve. The combined relationship is close to linear. A 10 percent reduction in heat output requires the stem to close 10 percent, a 50 percent reduction in heat output requires the stem to close 50 percent, and a 90 percent reduction in heat output requires the stem to close 90 percent.

The equal percentage valve compensates for the characteristics of a hot water application to provide a control that is close to linear.

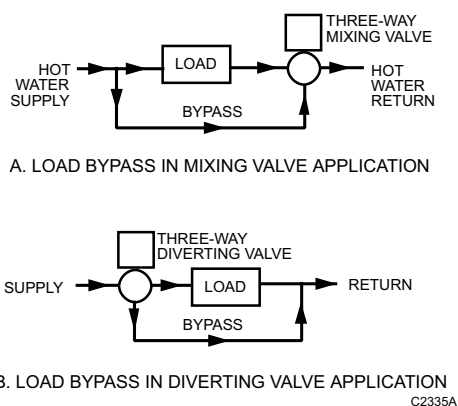

Fig. 13. Three-Way Valve Applications.

MIXING VALVE

A mixing valve provides two inlet ports and one common outlet port. The valve receives liquids to be mixed from the inlet ports and discharges the liquid through the outlet port (Fig. 12). The position of the valve disc determines the mixing proportions of the liquids from the inlet ports.

The close-off pressure in a mixing valve equals the maximum value of the greater inlet pressure minus the minimum value of the downstream pressure.

EXAMPLE:

A mixing valve application has a maximum pressure of 25 psi on one inlet port, maximum pressure of 20 psi on the other inlet port, and minimum downstream pressure of 10 psi on the outlet port. The close-off pressure is $25 \text{ psi} - 10 \text{ psi} = 15 \text{ psi}$. The application requires a mixing valve with at least a 15 psi close-off rating. The actuator selected must have a high enough force to operate satisfactorily.

In globe mixing valve applications, the force exerted on the valve disc due to unbalanced pressure at the inlets usually remains in the same direction. In cases where there is a reversal of force, the force changes direction and holds the valve disc off the seat, cushioning it as it closes. If the pressure difference for the system is greater than the pressure ratings of available globe mixing valves, use a ball mixing valve or two butterfly valves in a tee configuration.

Globe mixing valves are not suitable for modulating diverting valve applications. If a mixing valve is piped for modulating diverting service, the inlet pressure slams the disc against the seat when it nears the closed position. This results in loss of control, oscillations, and excessive valve wear and noise. Mixing valves are acceptable using about 80 percent of the close-off rating, but not recommended, in two-position diverting valve applications.

DIVERTING VALVE

A globe diverting valve provides one common inlet port and two outlet ports. The diverting valve uses two V-port plugs which seat in opposite directions and against the common inlet flow. The valve receives a liquid from one inlet port and discharges the liquids through the outlet ports (Fig. 12) depending on the position of the valve disc. If the valve disc is against the bottom seat (stem up), all the liquid discharges through the side outlet port. If the valve disc is against the top seat (stem down), all the liquid discharges through the bottom outlet port.

The close-off pressure in a diverting valve equals the maximum value of the inlet pressure minus the minimum value of the downstream pressure.

Globe diverting valves must not be used for mixing service. As with mixing valves used for diverting service, media pressure drop across the valve can cause it to slam shut with resulting loss of control.

EXAMPLE:

A diverting valve application has 20 psi maximum on the inlet port, one outlet port discharging to the atmosphere, and the other outlet port connecting to a tank under 10 psi constant pressure. The pressure difference between the inlet and the first outlet port is 20 psi and between the inlet and second outlet port is 10 psi. The application requires a diverting valve with at least 20 psi close-off rating.

Valve Sizing

Every valve has a capacity index or flow coefficient (C_v). Typically determined for the globe and ball valves at full open and about 60 degrees open for butterfly valves. C_v is the quantity of water in gpm at 60F that flows through a valve with a pressure differential of 1 psi. Sizing a valve requires knowing the medium (liquid or gas) and the required pressure differential to calculate the required C_v . When the required C_v is not available in a standard valve, select the next closest and calculate the resulting valve pressure differential at the required flow to verify acceptable performance.

After determination of the valve C_v , calculation of the flow of any medium through that valve can be found if the characteristics of the medium and the pressure drop across the valve are known.

Appendix A: Valve Selection and Sizing

Water Valves

Determine the capacity index (C_v) for a valve used in a water application, using the formula:

$$C_v = \frac{Q\sqrt{G}}{\sqrt{h}}$$

Where:

- Q = Flow of fluid in gallons per minute required to pass through the valve.
- G = Specific gravity of the fluid (water = 1).
- h = Pressure drop in psi. See Figures 14 and 15 for glycol solution correction values.

NOTE: The calculated C_v will rarely match the C_v of an available valve. For most accurate proportional control, select the valve with the next lower C_v value, and increase the pressure drop across the control valve to achieve the required flow through the coil by reducing the setting of the balancing valve. Otherwise, turn-down ratio will be reduced, proportionally.

For example, if the calculated C_v is 87, and the two closest C_v values are 63 and 100, the best choice for control precision would be the valve with a C_v of 63, and increase pressure drop across the valve by 90%.

If increased pressure drop is not possible, use the valve with C_v of 100, and accept a 13% reduction in valve rangeability.

For two-position control, always choose the largest C_v greater than the coil with acceptable close-off pressure rating.

Determining the C_v of a water valve requires knowing the quantity of water (gpm) through the valve and the pressure drop (h) across the valve. If the fluid is a glycol solution, use the pressure drop multipliers from either Figure 14 or 15. See the sections on QUANTITY OF WATER and WATER VALVE PRESSURE DROP. Then select the appropriate valve based on C_v , temperature range, action, body ratings, etc., per VALVE SELECTION guidelines.

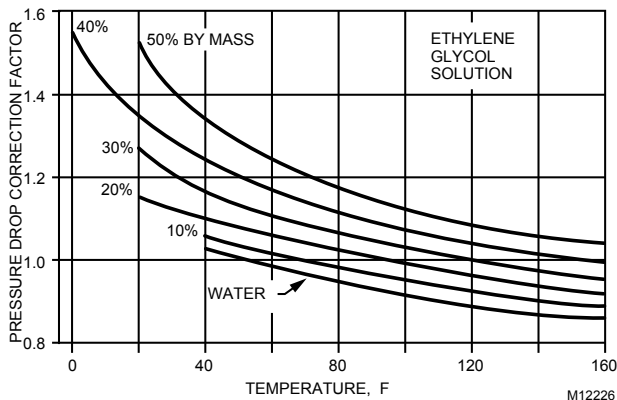

REPRINTED BY PERMISSION FROM ASHRAE HANDBOOK—
1996 HVAC SYSTEMS AND EQUIPMENT

Fig. 14. Pressure Drop Correction for Ethylene Glycol Solutions

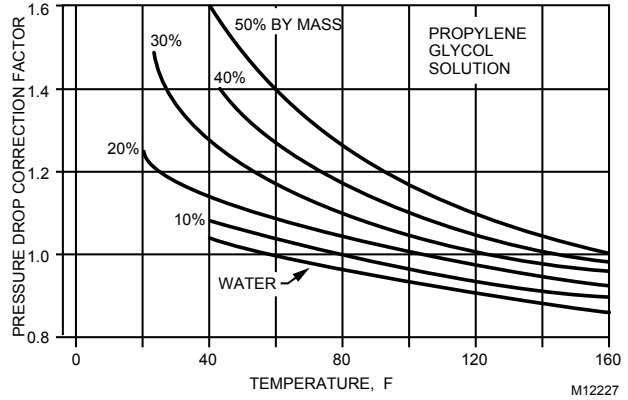

REPRINTED BY PERMISSION FROM ASHRAE HANDBOOK—
1996 HVAC SYSTEMS AND EQUIPMENT

Fig. 15. Pressure Drop Correction for Propylene Glycol Solutions.

Quantity of Water

To find the quantity of water (Q) in gallons per minute use one of the following formulas:

1. When Btu/hr is known:

$$Q = \frac{Btu/hr}{K \times TD_w}$$

Where:

- Btu/hr = Heat output.
- K = Value from Table 3; based on temperature of water entering the coil. The value is in pounds per gallon x 60 minutes per hour.
- TD_w = Temperature difference of water entering and leaving the coil.

Table 3. Water Flow Formula Table

Water		Water	
Temp F	K	Temp F	K
40	502	200	484
60	500	225	483
80	498	250	479
100	496	275	478
120	495	300	473
150	490	350	470
180	487	400	465

2. For hot water coil valves:

$$Q = \frac{cfm \times 1.08 \times TD_a}{K \times TD_w}$$

Where:

- cfm = Airflow through the coil.
- 1.08 = A scaling constant. See Note.
- TD_a = Temperature difference of air entering and leaving the coil.
- K = Value from Table 3; based on temperature of water entering the coil (pounds per gallon x 60 minutes per hour).
- TD_w = Temperature difference of water entering and leaving the coil.

NOTE: The scaling constant 1.08 is derived as follows:

$$1.08 = \frac{0.24 BTU}{lbairF} \times \frac{60 min}{1 hr} \times \frac{1 lbair}{13.35 ft^3}$$

Where:

$$\frac{1 lbair}{13.35 ft^3} = \text{the specific volume of air at standard conditions of temperature and atmospheric pressure.}$$

Simplifying the equation:

$$1.08 = \frac{14.40 Btumin}{Fhr 13.35 ft^3}$$

To find the scaling constant for air conditions other than standard, divide 14.40 Btu by specific volume of air at those conditions.

3. For fan system chilled water coil valves:

$$Q = \frac{cfm \times Btu/lb}{113 \times TD_w}$$

Where:

- cfm = Airflow through the coil.
- Btu/lb = Heat per pound of dry air removed. Includes both sensible and latent heat.
- 113 = A scaling constant.
- TD_w = Temperature difference of water entering and leaving the coil.

WATER VALVE PRESSURE DROP

To determine valve pressure drop:

1. For two-way valves consider the following guidelines for valve pressure drop:
 - a. Include the pressure drop in the design of the water circulating system.
 - In systems with two-way valves only, it is often necessary to provide a pump relief bypass or some other means of differential pressure control to limit valve pressure drops to the valve capabilities. For control stability at light loads, pressure drop across the fully closed valve should not exceed triple the pressure drop used for sizing the valve.
 - To avoid high pressure drops near the pump, reverse returns are recommended in large systems.
 - b. The pressure drop across an open valve should be about half of the pressure difference between system supply and return, enough so that the valve, not the friction through the coil or radiator, controls the volume of water flow or the valve pressure drop should be equal to or greater than the pressure drop through the coil or radiator, plus the pipe and fittings connecting them to the supply and return mains.
 - c. Verify allowable full open and full closed pressure drops for all proportional and two-position water valves with appropriate manufacturer literature.
 - d. Make an analysis of the system at maximum and minimum rates of flow to determine whether or not the pressure difference between the supply and return mains stays within the limits that are acceptable from the stand point of control stability and close-off rating.
2. For two- and three-way valves consider the following guidelines for valve pressure drop:
 - a. In load bypass applications (Fig. 13) such as radiators, coils, and air conditioning units, the pressure drop should be 50 to 70 percent of the minimum difference between the supply and return main pressure at design operating conditions.
 - b. A manual balancing valve may be installed in the bypass to equalize the load drop and the bypass drop.
3. When selecting pressure drops for three-way mixing valves in boiler bypass applications (Fig. 13), consider the following:
 - a. Determine the design pressure drop through the boiler including all of the piping, valves, and fittings from the bypass connection through the boiler and up to the three-way valve input.
 - b. The valve pressure drop should be equal to or greater than the drop through the boiler and the fittings. If the valve drop is much smaller than the boiler pressure drop at design, effective control is obtained only when the disc is near one of the two seats. The mid-portion of the valve lift will be relatively ineffective.

Appendix A: Valve Selection and Sizing

- c. A manual balancing valve may be installed in the boiler bypass to equalize the boiler drop and the bypass drop.

WATER VALVE SIZING EXAMPLES

EXAMPLE 1:

A two-way linear valve is needed to control flow of 45F chilled water to a cooling coil. The coil manufacturer has specified an eight-row coil having a water flow pressure drop of 3.16 psi. Further, specifications say that the coil will produce 55F leaving air with a water flow of 14.6 gpm. Supply main is maintained at 40 psig, return is at 30 psig. Select required capacity index (C_V) of the valve.

Use the water valve C_V formula to determine capacity index for Valve V1 as follows:

$$C_V = \frac{Q\sqrt{G}}{\sqrt{h}}$$

Where:

- Q = Flow of fluid in gallons per minute required is 14.6 gpm.
- G = Specific gravity of water is 1.
- h = Pressure drop across the valve. The difference between the supply and return is 10 psi. 50% to 70% x 10 psi = 5 to 7 psi. Use 6 psi for the correct valve pressure drop. Note that 6 psi is also greater than the coil pressure drop of 3.16 psi.

Substituting:

$$C_V = \frac{14.6\sqrt{1}}{\sqrt{6}} = 6$$

Select a linear valve providing close control with a capacity index of 6 and meeting the required pressure and temperature ratings.

EXAMPLE 2:

A bypass valve is required to prevent flow through the chiller from dropping below 90 percent of design flow. When sizing valves for pump or chiller bypass applications (Fig. 16), system conditions that cause the valve to open or close completely must be considered before a pressure drop can be selected.

Assume the following:

- System flow at design, 1000 gpm
- Pump head at design, 48 ft
- Pump head at 90 percent flow, 50 ft
- Pressure across mains at AHU 1 at design flow, 28 ft
- Chiller pressure drop, 12 ft
- Chiller piping loop design pressure drop, 8 ft

With full system flow, Valve V5 is closed. Pressure drop across V5 equals the pump head minus the friction drops to V5. Pressure drop across Valve V5 is then 48 ft – 12 ft (chiller drop) – 4 ft (supply drop) – 4 ft (return drop) or 28 ft.

With system flow at 90 percent, the pump head rises to 50 ft, while the friction drops fall to the lower values shown in Figure 16. For additional information on chiller bypass operation see Chiller, Boiler, and Distribution System Applications section. Pressure drop across V5 equals the pump head minus the friction drops to V5. Pressure drop across Valve V5 is then 50 ft – 9.6 ft (chiller drop) – 3.2 ft (supply drop) – 3.2 ft (return drop) or 34 ft. Converting ft to psi, 34 ft x 0.4335 psi/ft = 14.7 psi.

Substituting the flow of water, specific gravity of water, and pressure drop in the C_V formula shows that the Valve V5 should have a C_V of 235.

$$C_V = \frac{900\sqrt{1}}{\sqrt{14.7}} = 235$$

Appendix A: Valve Selection and Sizing

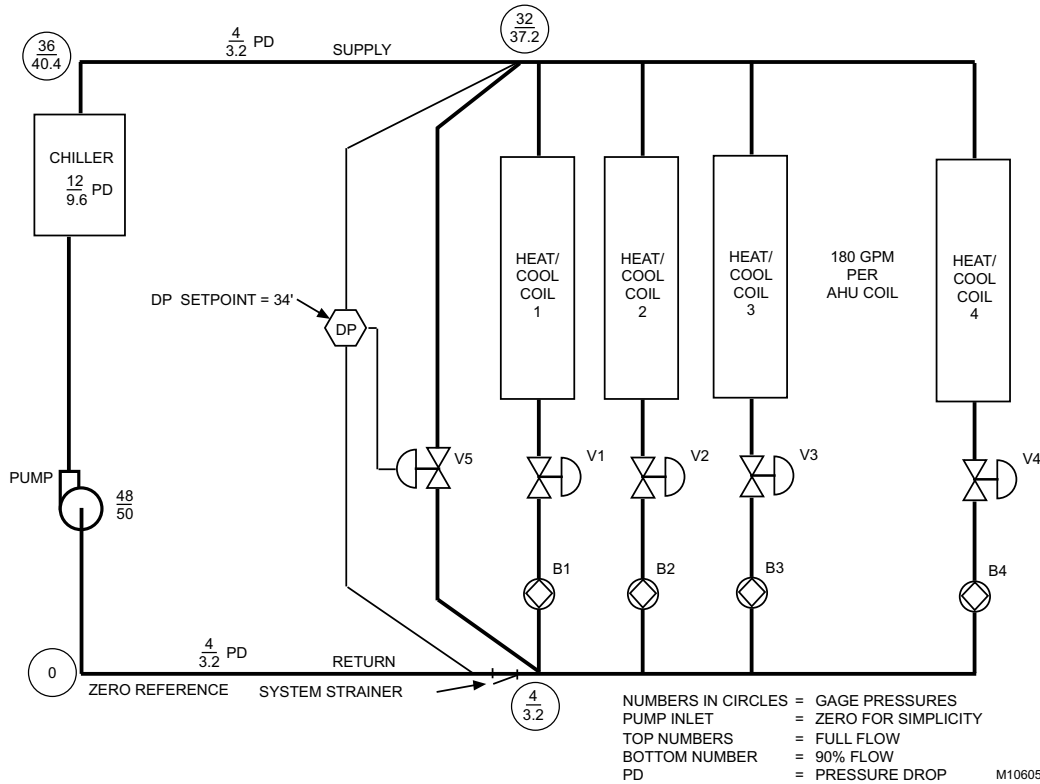

Fig. 16. Chiller Bypass Application.

EXAMPLE 3:

Sizing water valves for heating coils is especially critical. In Figure 17, a valve with a C_v of 12 will have 30 percent of the available pressure drop when full open, while a valve with a C_v of 5 will have 70 percent of the available pressure drop. As shown in Figure 18, the valve with 70 percent of the available pressure drop essentially provides the equal percentage water flow control, resulting in linear coil heat transfer and stable temperature control. The valve with only 30 percent of the available pressure drop has a more linear flow control which results in nonlinear coil heat transfer. See EQUAL PERCENTAGE VALVE section for further information.

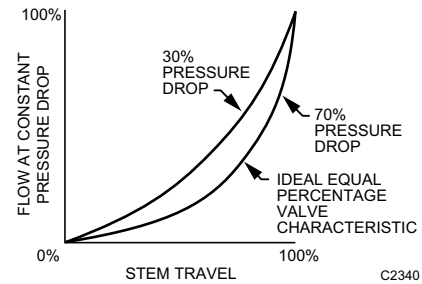

Fig 18. Effect of Pressure Drop in Hot Water Valve Sizing.

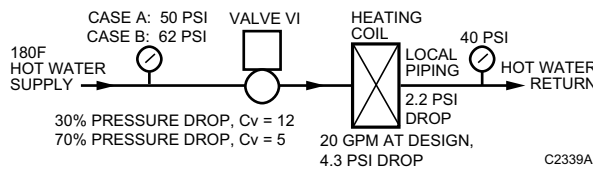

Fig. 17. Equal Percentage Valve Hot Water Application.

EXAMPLE 4:

A three-way mixing valve is needed for a heat exchanger application with a bypass line. Water flow is specified at the rate of 70 gpm. Manufacturer data for the exchanger indicates a pressure drop of 1.41 ft of water through the exchanger coils.

Appendix A: Valve Selection and Sizing

Use the water valve C_v formula to determine capacity index for Valve V1 as follows:

$$C_v = \frac{Q\sqrt{G}}{\sqrt{h}}$$

Where:

- Q = Flow of fluid in gallons per minute required to pass through the valve is 70 gpm.
- G = Specific gravity of water is 1.
- h = Pressure drop across the valve. Plans of the heating system indicate three-inch supply and return mains. From an elbow equivalent table and pipe friction chart found in the ASHRAE Handbook or other reference manuals, the calculated pressure drop through a three-inch tee and the piping from the valve and the tee to the exchanger is 0.09 psi. Heat exchanger pressure drop is 1.41 ft of water or 1.41 ft x 0.433 psi/ft = 0.61 psi. Total pressure drop from bypass connection through the heat exchanger and to the hot-water input of the three-way valve is 0.61 + 0.09 or 0.70 psi.

Since the valve pressure drop (h) should be equal to or greater than the drop through the heat exchanger and fittings, 0.70 psi is used as the valve pressure drop.

For optimum control, a manual balancing valve is installed in the bypass line to equalize the pressure drops in the exchanger and bypass circuits.

$$C_v = \frac{70\sqrt{1}}{\sqrt{0.70}} = 83.6 \text{ or } 84$$

Substituting the flow of water, specific gravity of water, and pressure drop in the C_v formula shows that the valve should have a C_v of 83.6 or 84.

Select a linear valve providing close control with a capacity index of 84 and meeting the required pressure and temperature ratings.

Steam Valves

Calculate the required capacity index (C_v) for a valve used in a steam application, using the formula:

$$C_v = \frac{(1 + 0.00075s)Q\sqrt{V}}{63.5\sqrt{h}}$$

Where:

- Q = Quantity of steam in pounds per hour required to pass through the valve.
- V = Specific volume of steam, in cubic feet per pound, at the average pressure in the valve. For convenience Table 5 at the end of the STEAM VALVES section lists the square root of the specific volume of steam for various steam pressures. Therefore, use the value in this column of the table as is; do not take its square root.
- 63.5 = A scaling constant.
- h = Pressure drop in psi.
- s = Superheat in degrees F.

Determining the C_v for a steam valve requires knowing, the quantity of steam (Q) through the valve, the pressure drop (h) across the valve, and the degrees of superheat. See QUANTITY OF STEAM and STEAM VALVE PRESSURE DROP. Then select the appropriate valve based on C_v , temperature range, action, body ratings, etc., per VALVE SELECTION guidelines.

NOTE: When the superheat is 0F, then (1 + 0.00075s) equals 1 and may be ignored.

QUANTITY OF STEAM

To find the quantity of steam (Q) in pounds per hour use one of the following formulas:

- When Btu/hr (heat output) is known:

$$Q = \frac{\text{Btu/hr}}{1000\text{Btu/lbsteam}}$$

Where:

- Btu/hr = Heat output.
- 1000 Btu/lb= A scaling constant representing the approximate heat of vaporization of steam.

- For sizing steam coil valves:

$$Q = \frac{\text{CFM} \times \text{TD}_a \times 1.08}{1000\text{Btu/lbsteam}}$$

Where:

- cfm = Cubic feet per minute (ft³/min) of air from the fan.
- TD_a = Temperature difference of air entering and leaving the coil.
- 1.08 = A scaling constant. See NOTE.
- 1000 Btu/lb= A scaling constant representing the approximate heat of vaporization of steam.

Appendix A: Valve Selection and Sizing

NOTE: The scaling constant 1.08 is derived as follows:

$$1.08 = \frac{0.24 BTU}{lbairF} \times \frac{60min}{1hr} \times \frac{1lbair}{13.35ft^3}$$

Where:

$$\frac{1lbair}{13.35ft^3} = \text{the specific volume of air at standard conditions of temperature and atmospheric pressure.}$$

Simplifying the equation:

$$1.08 = \frac{14.40 Btumin}{Fhr13.35ft^3}$$

To find the scaling constant for air conditions other than standard, divide 14.40 Btu by specific volume of air at those conditions.

3. For sizing steam to hot water converter valves:

$$Q = gpm \times TD_w \times 0.49$$

Where:

gpm = Gallons per minute of water flow through converter.

TD_w = Temperature difference of water entering and leaving the converter.

0.49 = A scaling constant. This value is derived as follows:

$$0.49 = \frac{8.33lbwater}{1gal} \times \frac{60min}{1hr} \times \frac{1lbsteam}{1000Btu} \times \frac{1Btu}{lbwaterF}$$

Simplifying the equation:

$$0.49 = \frac{0.49minlbsteam}{galhrF}$$

4. When sizing steam jet humidifier valves:

$$Q = \frac{(W_1 - W_2)lbmoisture}{lbair} \times \frac{1}{13.35ft^3} \times \frac{ft^3}{min} \times \frac{60min}{hr}$$

Where:

W1 = Humidity ratio entering humidifier, pounds of moisture per pound of dry air.

W2 = Humidity ratio leaving humidifier, pounds of moisture per pound of dry air.

$\frac{13.35ft^3}{lbair}$ = The specific volume of air at standard conditions of temperature and atmospheric pressure.

$\frac{ft^3}{min}$ = Cubic feet per minute (cfm) of air from the fan.

$\frac{60min}{hr}$ = A conversion factor.

Simplifying:

$$Q = 4.49 \frac{(W_1 - W_2)lbmoisture}{hr}$$

5. When Equivalent Direct Radiation (EDR) is known:

$$Q = EDR(Total) \times 0.24$$

Where:

EDR (Total)=Radiators are sized according to Equivalent Direct Radiation (EDR). If controlling several pieces of radiation equipment with one valve, add the EDR values for all pieces to obtain the total EDR for the formula.

0.24 = A scaling constant, lb steam/unit EDR. See Table 4.

Table 4. Output of Radiators and Convectors.

Average Radiator of Convector Temperature, Deg F	Cast Iron Radiator Btu/Hr/EDR ^a	Convector, Btu/Hr/EDR ^b
215	240	240
200	209	205
190	187	183
180	167	162
170	148	140
160	129	120
150	111	102
140	93	85
130	76	69
120	60	53
110	45	39
100	31	27
90	18	16

a At Room Temperature

b At 65 F Inlet Air Temperature

STEAM VALVE PRESSURE DROP

Proportional Applications

When specified, use that pressure drop (h) across the valve.

When not specified:

1. Calculate the pressure drop (h) across the valve for good modulating control:

$$h = 80\% \times (P_m - P_r)$$

NOTE: For a zone valve in a system using radiator orifices use:

$$h = (50 - 75)\% \times (P_m - P_r)$$

Where

P_m = Pressure in supply main in psig or psia (gage or absolute pressure).

P_r = Pressure in return in psia or psia. A

Appendix A: Valve Selection and Sizing

2. Determine the critical pressure drop:

$$h_{\text{critical}} = 50\% \times P_{\text{ma}}$$

Where:

P_{ma} = Pressure in supply main in psia (absolute pressure)

psia = psig + 14.7

Use the smaller value h or h_{critical} when calculating C_v .

Two-Position Applications

Use line sized valves whenever possible. If the valve size must be reduced, use:

$$h = 20\% \times (P_{\text{m}} - P_{\text{r}})$$

Where

P_{m} = Pressure in supply main in psig or psia (gage or absolute pressure).

P_{r} = Pressure in return in psig or psia. A negative value if a vacuum return.

STEAM VALVE SIZING EXAMPLES

EXAMPLE 1:

A two-way linear valve (V1) is needed to control high-pressure steam flow to a steam-to-water heat exchanger. An industrial-type valve is specified. Steam pressure in the supply main is 80 psig with no superheat, pressure in return is equal to atmospheric pressure, water flow is 82.5 gpm, and the water temperature difference is 20F.

Use the steam valve C_v formula to determine capacity index for Valve V1 as follows:

$$C_v = \frac{(1 + 0.00075s)Q\sqrt{V}}{63.5\sqrt{h}}$$

Where:

Q = The quantity of steam required to pass through the valve is found using the converter valve formula:

$$Q = \text{gpm} \times TD_w \times 0.49$$

Where:

gpm = 82.5 gpm water flow through exchanger

TD_w = 20F temperature difference

0.49 = A scaling constant

Substituting this data in the formula:

Q = 808.5 pounds per hour

h = The pressure drop across a valve in a modulating application is:

$$h = 85\% \times (P_{\text{m}} - P_{\text{r}})$$

Where:

P_{m} = Upstream pressure in supply main is 80 psig.

P_{r} = Pressure in return is atmospheric pressure or 0 psig.

Substituting this data in the pressure drop formula:

$$h = 0.80 \times (80 - 0)$$

$$= 0.80 \times 80$$

$$= 64 \text{ psi}$$

The critical pressure drop is found using the following formula:

$$h_{\text{critical}} = 50\% \times (\text{psig} + 14.7 \text{ psi})$$

$$h_{\text{critical}} = 0.50 \times (80 \text{ psig upstream} + 14.7 \text{ psi})$$

$$= 0.50 \times 94.7 \text{ psi}$$

$$= 47.4 \text{ psi}$$

The critical pressure drop (h_{critical}) of 47.4 psi is used in calculating C_v , since it is less than the pressure drop (h) of 64 psi. Always, use the smaller of the two calculated values.

V = Specific volume (V) of steam, in cubic feet per pound at average pressure in valve (P_{avg}):

$$P_{\text{avg}} = P_{\text{m}} - \frac{h}{2}$$

$$= 80 - \frac{47.4}{2} = 80 - 23.6 = 56.4 \text{ psig}$$

The specific volume of steam at 56.4 psig is 6.14 and the square root is 2.48.

63.5 = A scaling constant.

Substituting the quantity of steam, specific volume of steam, and pressure drop in the C_v formula shows that the valve should have a C_v of 4.6.

$$C_v = \frac{(1 + 0.00075 \times 0) \times 808.5 \times 2.48}{63.5 \sqrt{47.4}}$$

$$= \frac{1745.6}{63.5 \times 6.88} = 4.6$$

NOTE: If P_{avg} is rounded off to the nearest value in Table 5 (60 psi), the calculated C_v is 4.5 a negligible difference.

Appendix A: Valve Selection and Sizing

Select a linear valve providing close control with a capacity index of 4 and meeting the required pressure and temperature ratings.

NOTE: For steam valves downstream from pressure reducing stations, the steam will be superheated in most cases and must be considered.

EXAMPLE 2:

In Figure 19, a linear valve (V1) is needed for accurate flow control of a steam coil that requires 750 pounds per hour of steam. Upstream pressure in the supply main is 5 psig and pressure in the return is 4 in. Hg vacuum minimum.

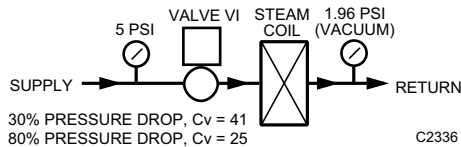

Fig. 19. Linear Valve Steam Application.

Use the steam valve C_V formula to determine capacity index for Valve V1 as follows:

$$C_V = \frac{(1 + 0.00075s)Q\sqrt{V}}{63.5\sqrt{h}}$$

Where:

- Q = Quantity of steam required to pass through the valve is 750 pounds per hour.
- h = The pressure drop across a valve in a modulating application is found using:
h = 80% x (Pm – Pr)
- and:
- Pm = Upstream pressure in supply main is 5 psig.
- Pr = Pressure in return is 4 in. Hg vacuum.

NOTE: 1 in. Hg = 0.49 psi and 1 psi = 2.04 in. Hg.

Therefore,
4 in. Hg vacuum = -1.96 psig.

$$\begin{aligned} h &= 0.80 \times [5 - (-1.96)] \\ &= 0.80 \times 6.96 \\ &= 5.6 \text{ psi} \end{aligned}$$

The critical pressure drop is found using the following formula:

$$h_{\text{critical}} = 50\% \times (\text{psig} + 14.7 \text{ psi})$$

$$\begin{aligned} h_{\text{critical}} &= 0.50 \times (5 \text{ psig upstream} + 14.7 \text{ psi}) \\ &= 0.50 \times 19.7 \text{ psia} \\ &= 9.9 \text{ psi} \end{aligned}$$

The pressure drop (h) of 5.6 psi is used in calculating the C_V , since it is less than the critical pressure drop (h_{critical}) of 9.9 psi.

V = Specific volume (V) of steam, in cubic feet per pound at average pressure in valve (P_{avg}):

$$\begin{aligned} P_{\text{avg}} &= P_m - \frac{h}{2} \\ &= 5 - \frac{5.6}{2} = 5 - 2.8 = 2.2 \text{ psig} \end{aligned}$$

The specific volume of steam at 2.2 psig is 23.54 and the square root is 4.85.

63.5 = A scaling constant.

s = 0

Substituting the quantity of steam, specific volume of steam, and pressure drop in the C_V formula shows that Valve V1 should have a C_V of 24.17 or the next higher available value (e.g., 25).

$$\begin{aligned} C_V &= \frac{(1 + 0.00075 \times 0) \times 750 \times 4.85}{63.5\sqrt{5.6}} \\ &= \frac{3637.5}{63.5 \times 2.37} = 24.17 \end{aligned}$$

NOTE: If P_{avg} is rounded off to the nearest value in Table 5 (2 psi), the calculated C_V is 24.30.

Select a linear valve providing close control with a capacity index of 25 and meeting the required pressure and temperature ratings.

EXAMPLE 3:

Figure 20 shows the importance of selecting an 80 percent pressure drop for sizing the steam valve in Example 2. This pressure drop (5.6 psi) approximates the linear valve characteristic. If only 30 percent of the available pressure drop is used ($0.30 \times 6.96 \text{ psi} = 2.10 \text{ psi}$ or 2 psi), the valve C_V becomes:

$$\begin{aligned} C_V &= \frac{(1 + 0.00075s)Q\sqrt{V}}{63.5\sqrt{h}} \\ C_V &= \frac{750 \times 4.85}{63.5\sqrt{2}} = 40.5 \end{aligned}$$

Appendix A: Valve Selection and Sizing

LINEAR VALVE under VALVE SELECTION for more information.

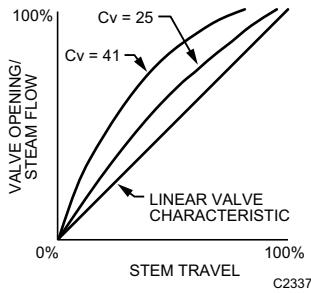

Fig. 20. Effect of Pressure Drop in Steam Valve Sizing.

Table 5. Properties of Saturated Steam.

Vacuum, Inches of Mercury	Boiling Point or Steam Temperature (Deg F)	Specific Volume (V), cu. ft/lb	\sqrt{V} (For valve sizing)	Maximum Allowable Pressure Drop, psi.
29	76.6	706.00	26.57	0.23
25	133.2	145.00	12.04	1.2
20	161.2	75.20	8.672	2.4
15	178.9	51.30	7.162	3.7
14	181.8	48.30	6.950	3.9
12	187.2	43.27	6.576	4.4
10	192.2	39.16	6.257	4.9
8	196.7	35.81	5.984	5.4
6	201.0	32.99	5.744	5.9
4	204.8	30.62	5.533	6.4
2	208.5	28.58	5.345	6.9

Gage Pressure, psig	Boiling Point or Steam Temperature (Deg F)	Specific Volume (V), cu. ft/lb	\sqrt{V} (For valve sizing)	Maximum Allowable Pressure Drop, psi.
0	212.0	26.79	5.175	7.4
1	215.3	25.20	5.020	7.8
2	218.5	23.78	4.876	8.4
3	221.5	22.57	4.751	8.8
4	224.4	21.40	4.626	9.4
5	227.1	20.41	4.518	9.8
6	229.8	19.45	4.410	10.4
7	232.3	18.64	4.317	10.8
8	234.8	17.85	4.225	11.4
9	237.1	17.16	4.142	11.8

Gage Pressure, psig	Steam Temperature (Deg F)	Specific Volume (V), cu. ft/lb	\sqrt{V} (For valve sizing)	Maximum Allowable Pressure Drop, psi.
10	239.4	16.49	4.061	12.4
11	241.6	15.90	3.987	12.8
12	243.7	15.35	3.918	13.4
15	249.8	13.87	3.724	14.8
20	258.8	12.00	3.464	17.4
25	266.8	10.57	3.251	19.8
30	274.0	9.463	3.076	22.4
35	280.6	8.56	2.93	24.8
40	286.7	7.826	2.797	27.4
45	292.4	7.209	2.685	29.8
50	297.7	6.682	2.585	32.4
55	302.6	6.232	2.496	34.8
60	307.3	5.836	2.416	37.4
65	311.8	5.491	2.343	39.8
70	316.0	5.182	2.276	42.4
75	320.0	4.912	2.216	44.8
80	323.9	4.662	2.159	47.4
85	327.6	4.445	2.108	49.8
90	331.2	4.239	2.059	52.4
95	334.6	4.060	2.015	54.8
100	337.9	3.888	1.972	57.4
110	344.1	3.595	1.896	62.3
120	350.0	3.337	1.827	67.4
130	355.2	3.12	1.766	72.3
140	360.9	2.923	1.710	77.4
150	366.2	2.746	1.657	82.3
160	370.6	2.602	1.613	87.4
170	375.5	2.462	1.569	92.3
180	379.6	2.345	1.531	97.4
190	383.9	2.234	1.495	102.3
200	387.8	2.134	1.461	107.4
225	397.4	1.918	1.385	119.8
250	406.0	1.742	1.320	132.4
275	414.2	1.595	1.263	145.0
300	421.8	1.472	1.213	157.4
350	435.6	1.272	1.128	182.4
400	448.1	1.120	1.058	207.4
450	459.5	0.998	0.999	232.4
500	470.0	0.900	0.949	257.4
550	479.7	0.818	0.904	282.4
600	488.8	0.749	0.865	307.4
650	497.3	0.690	0.831	332.4
700	505.4	0.639	0.799	357.4
800	520.3	0.554	0.744	407.4
900	533.9	0.488	0.699	457.4
1000	546.3	0.435	0.659	507.4

Appendix B: NEMA Standard Classification Code for Enclosures

NEMA 1—General purpose. for indoor protection, where conditions are not unusually severe.

NEMA 2—Drip tight. Designed to exclude falling moisture or dirt. Particularly applicable to cooling rooms, laundries, etc., where condensation is prevalent. For indoor use.

NEMA 3—Weather Resistant (weatherproof). For outdoor use; designed to withstand all normal exposure to natural elements. Controls mounted on pullout racks for easy access. With rain hood and weather seals.

NEMA 4—Watertight. Withstands water pressure from 1 in. hose nozzle, 65 gallons per minute, from distance of not less than 10 ft for five minutes. Suitable for maritime applications, breweries, etc.

NEMA 5—Dust-tight. Equipped with dust-tight gaskets. Suitable for mills and other high-dust atmospheres.

NEMA 6—Submersible. For submerged operation under specified pressures and time.

NEMA 7—Hazardous Locations, National Electrical Code Class 1 (circuit breaks in air).

NEMA 8—Hazardous Locations, National Electrical Code Class 1 (circuit breaks immersed in oil).

NEMA 9—Hazardous Locations, National Electrical Code Class 2.

NEMA 10—Explosion-proof. Meets U.S. Bureau of Mines requirements for explosive atmospheres.

NEMA 11—Acid or Fume Resistant. Provides for immersion of enclosed equipment in oil.

NEMA 12—Industrial Use. Excludes oils, dust, moisture, to satisfy individual requirements.

Appendix C: Best Practices for Low Power Control Signal Wiring

Low power analog signals are commonly used for proportional control signal wiring in HVAC applications. Following are a series of best practices for the prevention of corruption of these signals due to electro-magnetic interference (“EMI”).

EMI is typically caused by coupling of the electro-magnetic field that surrounds all wires carrying current. It may also be caused by radio frequency sources such as “walkie talkies” using amplitude modulated signals. A strong EM field can induce electrical noise in wires up to 2 V in amplitude. The strongest coupling comes between closely spaced, parallel wires. Inductive and high power motor loads are some of the strongest sources of EMI, along with electronics lighting ballasts, dimmers, and variable frequency motor drives. More potential EMI sources in a building mean that greater attention needs to be paid to effective wiring practices.

All control wiring should consist of twisted pairs of wires, which resist interference better than straight, non-twisted conductors. Stranded conductors offer less resistance to current flow than solid wires, and are more flexible making them easier to install; however, care must be taken to ensure that all the conductors in the wire are properly installed and that “whiskers” do not short out any wiring connections.

Shielded Wiring

Control signals can be protected from EMI using shielded wire. The more continuous the shield, the more effective it is. Braided shield is commonly used for microphone cables because of its superior flexibility. HVAC wiring is fixed, does not require high flexibility during use, and is better served with lower cost cables using continuous foil shielding and a “drain wire”.

1. All signal wiring in hospitals should be shielded to prevent the potential for interference with medical equipment such as high power MRI and CT scanners.
2. All 0~10 Vdc control signals should be run in shielded cable. EMI noise can be interpreted as control signaling, depending on the noise suppression circuitry in the controlled equipment.
3. Long runs of wiring from 24 V power supply transformers should be shielded in heavy electrical noise environments to prevent EMI from coupling through the actuator’s power supply.
4. In typical commercial buildings, 2~10 Vdc signals do not require shielded wiring.
5. Current flow is much more difficult to induce in wiring than voltage, and current-based control signals usually do not require shielded cable except in heavy industrial applications.
 - a. If the terminal equipment only accepts voltage input, install a 500 ohm, ¼ Watt (or larger), 1% resistor across the control input terminals to convert a 4~20 mA(dc) signal to 2~10 Vdc.
 - b. If multiple actuators are connected in parallel, install this resistor at the first actuator in the group.

- c. Any standard resistor (“EIA”) value between 490 and 510 ohms is acceptable, and can be purchased at retail outlets that sell electronic components.
6. Floating, pulse-width modulated, and two-position actuators use switched 24 Vac control or power signals and so rarely require shielded wiring.

Wiring Techniques

1. No wiring should ever be assumed to be interference-proof. Never strap signal cables to other conductors or conduit, especially line voltage.
2. Never run signal wires in raceways or wiring troughs with other conductors. Keep signal wires at least a yard away from line voltage wiring. Higher voltage wiring requires greater separation.
3. When necessary, cross line voltage conductors with signal wiring at 90° (right angles), to minimize signal coupling.
4. Electromagnetic shielding is a static phenomenon; any current running through the shield will negate any protection the shield may have provided. Only ground (or “earth”) a shield drain wire at one point, preferably where the signal will be the weakest, for example: at the actuator.
 - a. Do not ground the secondary of the 24 V power supply in the control system. This will create a secondary current path and negate the protection of any shielding.
 - b. If there is a burner ignition system, power it with its own transformer and use an interface relay for isolation, if necessary.
 - c. Use relays with built-in coil arc suppression, such as a Honeywell R8229.
5. Insulate all exposed shielding and drain wire joins and splices so that they cannot contact electrical ground, especially junction boxes and conduit. Do not use the ground screw of a junction box as a tie point. Use a separate electrical ground wire if required for safety extra-low voltage wiring by local code.
6. Both rigid and flexible conduit are continuously grounded (“bonded”) for electrical safety, and cannot function as a signal shield. Where local codes require mechanical protection for all wiring, shielded signal cable may be run inside conduit, following the practices listed above.

Additional References

Most of these wiring techniques were developed to protect the very low-strength signals in audio recording. The 20 mA current loop signal was originally used with teletype (“TWX”) equipment communicating over telephone lines and adapted for proportional analog control signaling in industrial process control. Further information and background theory can be found in:

1. Audio Engineering Handbook, edited by Blair K. Benson, McGraw-Hill
2. Handbook for Sound Engineers, by Glen Ballou
3. Standard Handbook of Audio Engineering, by Jerry Whittaker and Blair K. Benson, McGraw-Hill.

Honeywell

AUTOMATION AND CONTROL PRODUCTS

WARRANTY POLICY

Honeywell warrants the products in this catalog (except those parts designated on Honeywell's price lists as not covered by this warranty) to be free from defects due to workmanship or materials, under normal use and service, for the following warranty periods. Honeywell VisionPRO®, Commercial VisionPRO™, FocusPRO®, PRO 4000, PRO 3000, LineVolt™ PRO, Digital Round™, and Modern Round™ (T87K, N) Series Thermostats with a date code of 0501 or later: sixty (60) months from date of installation. CommercialPRO, PRO 2000 and PRO 1000 thermostats: twenty-four (24) months from date of installation. AUBE branded thermostats, timers, and switches: thirty-six (36) months from date of installation. All other Honeywell thermostats and thermostats with a date code of 0452 or earlier: twelve (12) months from date of installation, unless specified otherwise. Honeywell Air Cleaners, Humidifiers, Ventilators, Ultraviolet Treatment and Zoning Products with a date code of 0501 or later, excluding replacement maintenance parts: sixty (60) months from date of installation. Indoor air quality parts F50, F52, F300, F200, F150, UV100E, HE225, HE265, HE365, with date codes of 0452 or earlier, excluding replacement maintenance parts: sixty (60) months from date of installation. All other Honeywell indoor air quality and zoning products with a date code of 0452 or earlier: twenty-four (24) months from date of installation, unless specified otherwise. Variable frequency drive devices (VFD) and accessories: new products for thirty-six (36) months and factory refurbished drives for twelve (12) months from date of installation when start-up and commissioning is performed by Honeywell VFD Authorized and trained personnel. All VFD warranty return products must have prior authorization (Form No. 87-0284) and be returned only to the VFD Service Center in Chattanooga, TN. MS, MN and Fact Acting 2-position Direct Coupled Actuators: sixty (60) months from date of installation. The warranty period for all other products is twelve (12) months from date of installation.

If a product is defective due to workmanship or materials, is removed within the applicable warranty period, and is returned to Honeywell in accordance with the procedure described below, Honeywell will, at its option, either repair, replace or credit the customer for the purchase price of the product, in accordance with the procedure described below. This warranty extends only to persons or organizations who purchase products in this catalog for resale.

The expressed warranty above constitutes the entire warranty of Honeywell with respect to the products in this catalog and IS IN LIEU OF ALL OTHER WARRANTIES, EXPRESS OR IMPLIED, INCLUDING ANY WARRANTY OF MERCHANTABILITY OR WARRANTY OF FITNESS FOR A PARTICULAR PURPOSE. IN NO EVENT SHALL HONEYWELL BE RESPONSIBLE FOR ANY CONSEQUENTIAL DAMAGES OF ANY NATURE WHATSOEVER.

INSTRUCTIONS—INSTALLING OR SERVICING CONTRACTOR OR DEALER

When replacing a Honeywell product under warranty, including those products furnished on original heating and/or cooling equipment, you should rely on your local Honeywell Wholesaler or Distributor for prompt and efficient product replacement service.

A Honeywell Returned Goods Identification Tag (form 87-0030) or an electronic data notification system must be completed and approved by the servicing dealer/contractor prior to submitting the product to the Honeywell Wholesaler or Distributor. (Tags may be obtained from the Wholesaler or Distributor in advance.) No warranty claim for product replacement or credit will be honored by the Wholesaler/Distributor without a completed warranty tag attached or electronic notification.

INSTRUCTIONS—WHOLESALE OR DISTRIBUTOR

The following will apply to the return of any product to Honeywell under this warranty:

Any products which are not variable frequency drives and are:

- (i) identified with Honeywell's Returned Goods Identification Tag (form 87-0030), or electronic notification system;
- (ii) are listed individually with Returned Goods ID Tag numbers and date codes

listed on Honeywell's Returned Goods Order (form 71-96024) or a similar form;

- (iii) packed separately from other returns and protected from shipping damage;
- (iv) have certification by the installer or servicing dealer that the product was removed, due to failure, within the applicable warranty period;
- (v) are received transportation pre-paid at:
Honeywell Return Goods
Dock 4 MN10-3860
1885 Douglas Drive
Golden Valley, MN 55422
- (vi) and are found by Honeywell's inspection to be defective in workmanship or materials under normal use and service

will be handled in accordance with one of the two following procedures, as specified by the customer making the return:

All VFD warranty return products must have prior authorization (Form No. 87-0284) and be returned only to the VFD Service Center in Chattanooga, TN.

1. **CREDIT PROCEDURE.** Honeywell will issue credit, at Honeywell's lowest wholesaler net price in effect at the time of the return (as set forth on Honeywell's then current price sheet) or at the actual invoice amount if a copy of that invoice is attached to the packing list. (TRADELINE Replacement Exchange Products will be at Honeywell's lowest replacement exchange net price in effect at the time

of such return, as shown on Honeywell's then current price sheet.) Honeywell reserves the right to disallow this credit option in cases of warranty abuse.

2. **REPAIR OR REPLACEMENT PROCEDURE.** Honeywell will, at its option, either repair or replace the product free of charge and return it or its replacement lowest cost transportation prepaid. The replacement will be a functionally equivalent new TRADELINE product. Premium transportation will be used at customer's request and expense.

The warranty will not be honored if:

- (i) product is damaged or missing parts or accessory items including batteries.
- (ii) product exhibits evidence of field misapplications.

Final disposition of any warranty claim will be determined solely by Honeywell. If inspection by Honeywell does not disclose any defect covered by the warranty, the product will be returned or scrapped as instructed by the customer and Honeywell's regular service charges will apply. Products returned to the customer may be sent shipping charges collect.

If you have any questions relative to product returns to Honeywell, contact your Customer Care Representative:

Honeywell International Inc.
Customer Care MN10-1461
1985 Douglas Drive
Golden Valley, MN 55422
(763) 954-5720

SPECIAL MESSAGE TO INDUSTRIAL USERS AND BUILDING OWNERS

Thank you for using Honeywell products.

As a user, when you purchase a Honeywell product from this catalog you should expect performance from the product and, if it fails, replacement of the product by the installing dealer.

Typically, you will have purchased a Honeywell product under the following circumstances:

1. To modernize or refurbish your existing commercial and/or process control system.
2. You have purchased new commercial and/or process heating, cooling, air cleaning or humidification equipment that

is furnished with Honeywell controls or components (refer to your owner's manual furnished with the equipment).

3. A control has failed on your existing commercial and/or process heating and/or cooling equipment and is replaced by a Honeywell TRADELINE product.

With few exceptions, you utilize the services of a competent plumbing, heating and/or cooling dealer/contractor for new or replacement work performed.

Although our warranty does not extend to you, Honeywell does extend a warranty to your supplier.

Your supplier can rely on its local Honeywell Wholesaler/Distributor or Honeywell for prompt replacement.

If you have any questions, need additional information or would like to comment on Honeywell's products or services, please write or phone:

Honeywell International Inc.
Customer Care MN10-1461
1985 Douglas Drive North
Golden Valley, MN 55422-4386
(763) 954-5720

or check your telephone directory (white pages) for one of many Honeywell field sales offices.

Automation and Control Solutions

In the US:

Honeywell

1985 Douglas Drive North

Golden Valley, MN 55422-3992

In Canada:

Honeywell Limited

35 Dynamic Drive

Toronto, Ontario M1V 4Z9

customer.honeywell.com

Honeywell

63-9271 PR
March 2009
© 2009 Honeywell International Inc.

Free Manuals Download Website

<http://myh66.com>

<http://usermanuals.us>

<http://www.somanuals.com>

<http://www.4manuals.cc>

<http://www.manual-lib.com>

<http://www.404manual.com>

<http://www.luxmanual.com>

<http://aubethermostatmanual.com>

Golf course search by state

<http://golfingnear.com>

Email search by domain

<http://emailbydomain.com>

Auto manuals search

<http://auto.somanuals.com>

TV manuals search

<http://tv.somanuals.com>