

# Hoshizaki America, Inc.

## Commercial Freezers TempGuard® Series

Models  
FH2-SSB(-HD)



“A Superior Degree  
of Reliability”

[www.hoshizaki.com](http://www.hoshizaki.com)

## PARTS LIST



Number: 71230  
Issued: 3-8-1999  
Revised: 9-3-2008

# CONTENTS

Auxiliary Codes.....	3
Note About Ordering Parts .....	3
Material Abbreviations .....	4
A. Reach-In.....	5
FH2-SSB(-HD) .....	5
B. Refrigeration System.....	8
FH2-SSB(-HD) .....	8
C. Control Panel Assembly .....	11
FH2-SSB(-HD) .....	11
D. Body-Final .....	12
FH2-SSB .....	12
FH2-SSB-HD.....	15
E. Panel-Front Hinged Assembly .....	18
FH2-SSB(-HD) .....	18
F. Label Location.....	19
FH2-SSB(-HD) .....	19
G. Evaporator Fan Shroud Assembly .....	20
FH2-SSB(-HD) .....	20
H. Evaporator Assembly .....	21
FH2-SSB(-HD) .....	21
J. Condenser Assembly .....	23
FH2-SSB(-HD) .....	23
K. Control Box Assembly .....	26
FH2-SSB .....	26
FH2-SSB-HD.....	28
KK. Common Control Box.....	30
FH2-SSB(-HD) .....	30
L. Body-Prefinal .....	32
FH2-SSB(-HD) .....	32
M. Door-Right .....	34
FH2-SSB .....	34
N. Door-Left .....	36
FH2-SSB .....	36
P. Mullion-Vertical.....	38
FH2-SSB .....	38
Q. Door-Half (UR) .....	40
FH2-SSB-HD.....	40
R. Door-Half (LR).....	41
FH2-SSB-HD.....	41
S. Door-Half (UL) .....	42
FH2-SSB-HD.....	42
T. Door-Half (LL) .....	43
FH2-SSB-HD.....	43
U. Mullion-Cross .....	44
FH2-SSB-HD.....	44
V. Literature & Packaging.....	46
FH2-SSB(-HD) .....	46

## Auxiliary Codes

<b>FH2-SSB</b>	H-0	October 1998
	J-0	December 1998
	J-1	September 1999
	J-2	October 1999
	L-5	March 2001
	M-5	February 2002
	M-6	March 2002
	M-7	September 2002
	N-5	December 2002
	N-6	January 2003
	P-5	March 2004
	P-6	August 2004
	Q-5	December 2004

<b>FH2-SSB-HD</b>	J-1	October 1999
	L-5	April 2001
	M-6	March 2002
	M-7	August 2002
	N-6	January 2003
	P-5	December 2003
	P-6	August 2004
	Q-5	December 2004

## Auxiliary Code Breakdown

K-5

- Designates the year. "K" indicates the year 2000. Years progress or regress in alphabetical order. "J" is 1999, "L" is 2001, "M" is 2002, and so on. The letters "I" and "O" were skipped.
- Designates significant part changes within the same year for this model. Base is 5 (0 for auxiliary codes prior to L) and this number advances for each change.

Example: P-6

- "P" indicates 2004.
- "6" indicates the first significant part change for 2004.

## Note About Ordering Parts

Most assemblies cannot be ordered as complete units; parts in the assemblies generally must be ordered separately.

## Material Abbreviations

### ALUMINUM

AL = Aluminum

### COPPER

CU = Copper

### PLASTIC

ABS = Acrylonitrile -butadiene - styrene  
AC = Polyacetal  
EVA = Ethylene vinyl acetate  
PA = Polyamide = Nylon  
PC = Polycarbonate  
PE = Polyethylene  
PES = Polyester  
PETP = Polyethylene terephthalate = Tetlon  
PP = Polypropylene  
PS = Polystyrene  
PTFE = Polytetrafluoroethylene = Teflon  
PUR = Polyurethane  
PVC = Polyvinyl chloride

### RUBBER

VN = Vinyl Nitrile  
EPDM = EP rubber  
NBR = Nitrile butadiene rubber  
NR = Natural rubber  
NP = Neoprene  
SI.R = Silicone rubber  
SY.R = Synthetic rubber  
EPH = Epichlorohydrin

### STEEL

GS = Galvanized steel  
SS = Stainless steel  
PS = Plated steel  
PAS = Primed steel

**A. Reach-In**  
**FH2-SSB(-HD)**  
H-0, J-0, J-1, J-2

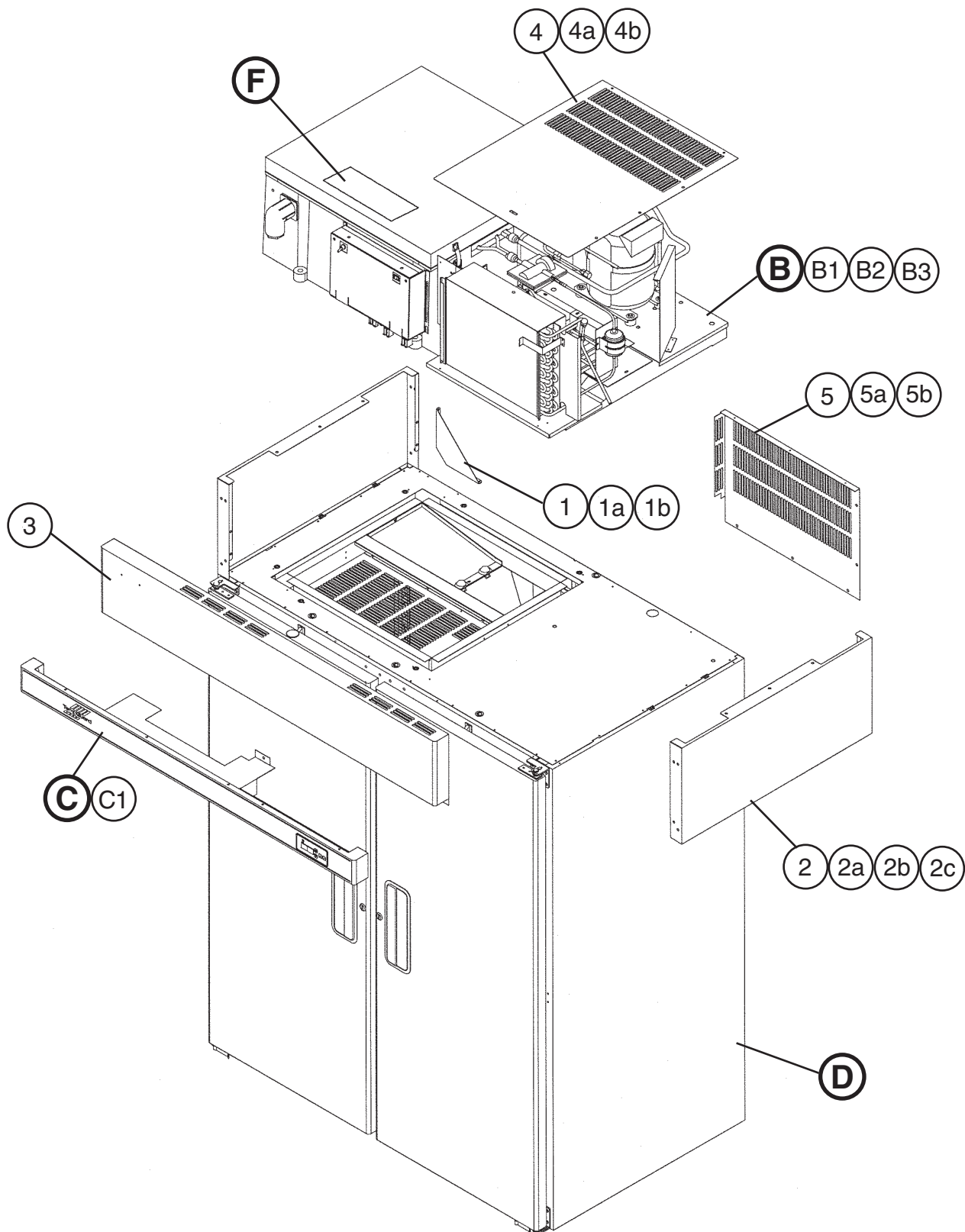

**A. Reach-In  
FH2-SSB(-HD)**

L-5, M-5, M-6, M-7, N-5, N-6, P-5, P-6, Q-5

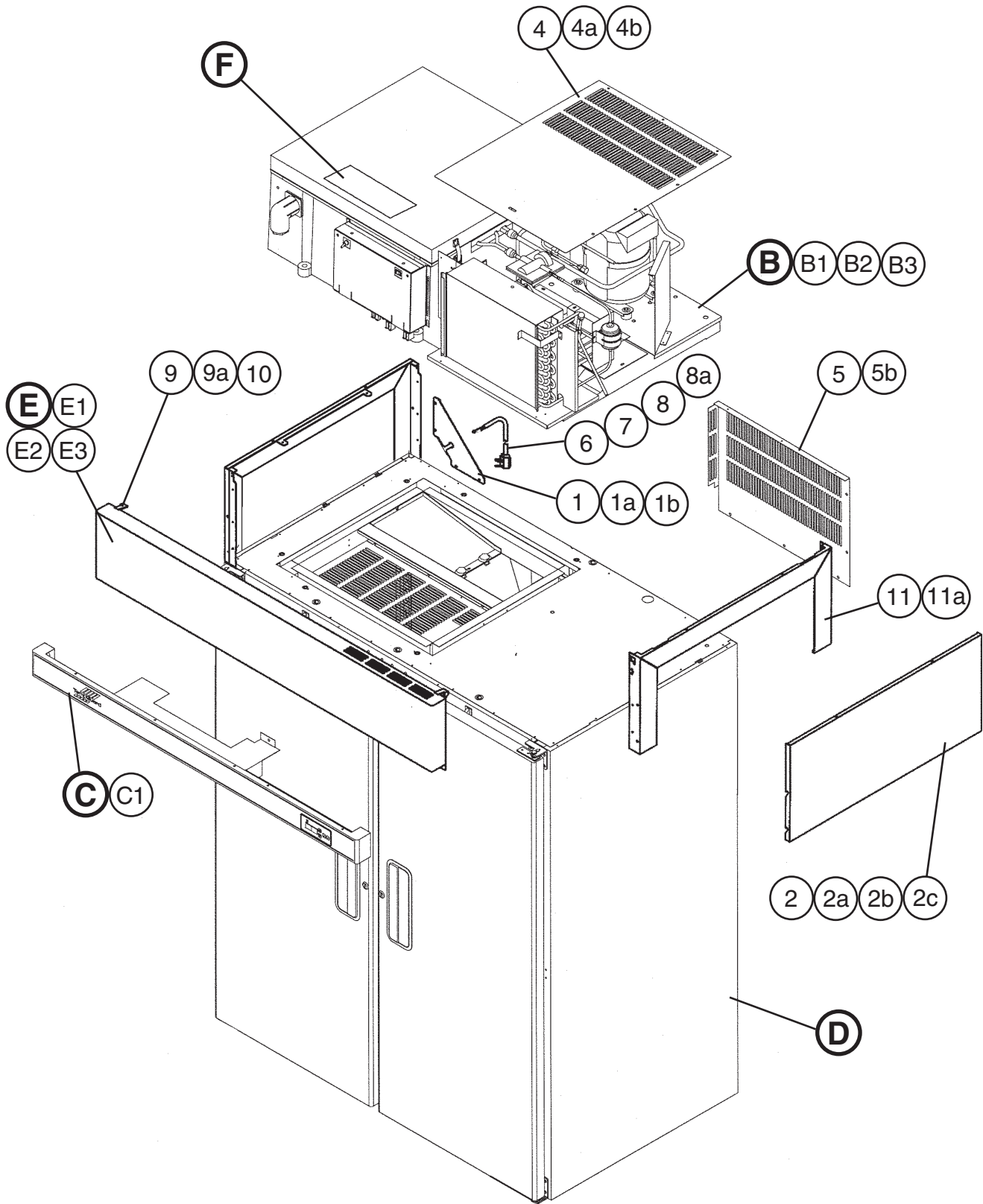

Title: **A. Reach-In** Model: **FH2-SSB(-HD)**

Index No.	Description	Material or Model Number	Part Number	Required Number										
				H-0 to J-2	L-5	M-5 to N-5	N-6 to Q-5							
B	Refrigeration System	Freezer	1A0255A01	1	1	1	1							
B1	Bolt Assembly	8x45	437889-01	6	6	6	6							
B2	Truss Head Screw	5x10, SS	7C32-0510	2	2	2	2							
B3	Washer	8	7W22-0800	2	2	2	2							
C	Control Panel Assembly	-	2A1219A02	1	1	1	1							
C1	T2 Screw	4x8, SS	7P32-0408	7	7	7	7							
D	Body-Final	<b>FH2-SSB</b>	2A1215A02	1	-									
			2A1215A06		1	1	1							
		<b>FH2-SSB-HD</b>	1A0370A01	1	-									
			1A0370A04		1	1	1							
E	Panel-Front Hinged Assembly	-	2A2011A02		1	1	1							
E1	Clevis Pin	-	8907-0102		2	2	2							
E2	Cotter Pin	-	8907-0103		2	2	2							
E3	Flat Washer		4A0655-03		2	2	2							
F	Label Location	<b>FH2-SSB</b>	3A0603G01	1	1	1	1							
		<b>FH2-SSB-HD</b>	3A0603G04	1	1	1	1							
1	Gusset-Side Top	GS	3A1006-01	1	-									
	Gusset-Frame		4A2845-01		1	1	1							
1a	T2 Screw	4x8, SS	7P32-0408	2	4	4	4							
1b	Truss Head Screw	5x10, SS	7C32-0510	2	-									
2	Panel-Side, Top	SS	2A0615-02	2	-									
			2A1800-01		2	2	2							
2a	Insert-Threaded	M5	4A0407-01	10	4	4	4							
2b	Taper Collar	SS	4H0171-01	4	4	4	4							
2c	Screw Countersunk	5x20,SS	7C42-0520	4	4	4	4							
3	Panel - Front	SS	1A0040-01	1	- See "E" above									
4	Cover-UL, Top	GS	2A1118-01	1	-									
			2A1118-03		1	1	1							
4a	Truss Head Screw	5x10, SS	7C32-0510	3	-									
4b	T2 Screw	4x8, SS	7P32-0408	2	5	5	5							
5	Cover-UL, Rear	GS	2A1117-01	1	1	1	1							
5a	Truss Head Screw	5x10, SS	7C32-0510	2	-									
5b	T2 Screw	4x8, SS	7P32-0408	3	5	5	5							
6	Power Cordset	-	4A1543-01	Shown on assy K	1	1	1							
7	Bushing	SB-625-8	420470-01				1							
8	Wire Clamp	-	4A0809-03		1	1	1							
8a	T2 Screw	4x8,SS	7P32-0408		1	1	1							
9	Spacer-Hinge		4A2473-01		2	2	2							
9a	Countersunk Screw	5x20, SS	7C42-0520		2	2	2							
10	Bracket-Hinge		4A2306-01		2	2	2							
11	Frame-Side Top	GS	2A1803-01		2	2	2							
11a	Truss Head Screw	5x10,SS	7C32-0510		8	8	8							

## B. Refrigeration System FH2-SSB(-HD)

H-0, J-0, J-1, J-2, L-5, M-5, M-6, M-7, N-5, N-6, P-5, P-6, Q-5

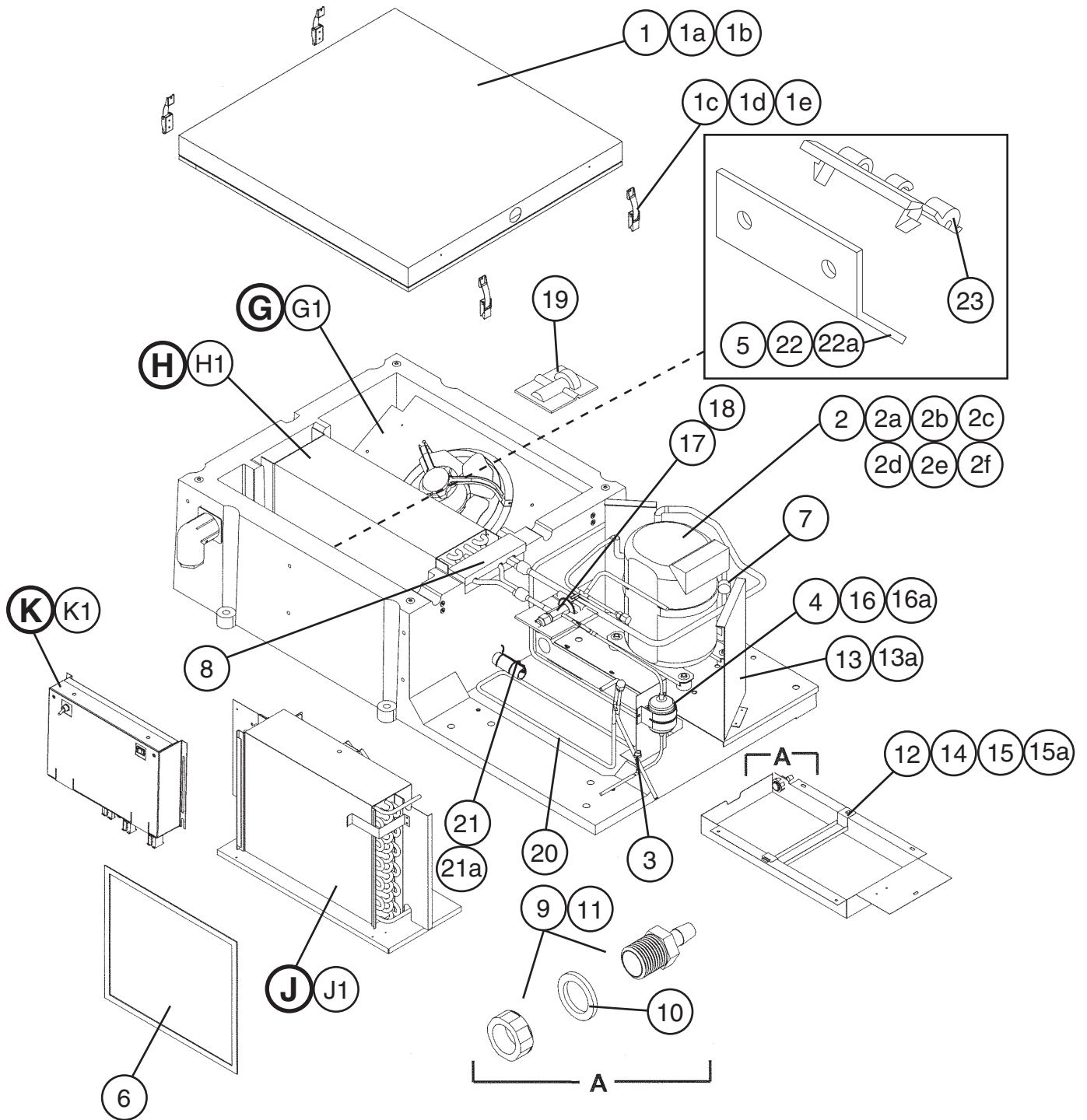



Title: <b>B. Refrigeration System</b> Model: <b>FH2-SSB(-HD)</b>													
Index No.	Description	Material or Model Number	Part Number	Required Number									
				H-0	J-0 to J-2	L-5	M-5 to P-5	P-6 Q-5					
G	Evap Fan Shroud Assembly	-	3A0263G01	1	1	1	1	-					
			3A0263G02					1					
G1	Truss Head Screw	4x16, SS	7C32-0416	4	4	4	4	4					
H	Evaporator Assembly	-	2A1015A01	1	1	1	1	1					
H1	T2 Screw	4x8, SS	7P32-0408	2	2	2	2	2					
J	Condenser Assembly	-	3A1138A01	1	1	-							
			3A0585A01			1	1	1					
J1	T2 Screw	4x8, SS	7P32-0408	4	4	4	4	4					
K	Control Box Assembly	-	2A1206A01	1	1	1	1	1					
K1	Truss Head Screw	4x16,SS	7C32-0416	4	4	4	4	4					
1	Cover-Evap Case	-	2A0245G01	1	1	1	1	1					
1a	Hex Head Bolt	1/4-20x3.25"	7C1111432	4	-								
1b	Washer	Flat	4A0521-02	4	-								
1c	Draw Latch	97-50-224-11	4A1710-01		4	4	4	4					
1d	Truss Head Screw	4x16,SS	7C32-0416		4	4	4	4					
1e	T2 Screw	4x8, SS	7P32-0408		8	8	8	8					
2	Compressor	RS80C1E-CAA-219	4A1346-01	1	1	1	1	1					
2a	Grommet	EPDM	434403-01	4	4	4	4	4					
2b	Spacer	Tecumseh 70459	434404-01	4	4	4	4	4					
2c	Hex Bolt	8x45	7B01-0845	4	4	4	4	4					
2d	Washer-Flat	8	7W21-0800	4	4	4	4	4					
2e	Split Lock Washer	8	7L21-0800	4	4	4	4	4					
2f	Protector	071-0518-06	4A1877-05	1	1	1	1	1					
3	Switch-Pressure		4A2516-02	Shown on assembly J		1	1	1					
4	Drier	Sporlan CW-052-S	4A0924-01	1	1	1	1	1					
5	Thermistor-Cabinet	Taiko 4A1429	4A1429-02	1	1	-							
		-	4A1429-01			1	1	1					
6	Filter-Condenser	-	3A0277-01	1	1	-							
			3A0277-02			1	1	1					
7	Thermostat-Clean Filter	-	4A0965-01	1	1	1	1	1					
8	Seal-Evap Tubing	Neoprene/EPDM	3A0972-01	2	2	2	2	2					
9	Fitting-Drain Overflow	PP	4A0664-01	1	1	-							
		-	4A2182-01			1	1	1					
10	Washer-Drain Overflow	Rubber	4A0665-01	1	1	-							
			413854-03			1	1	1					
11	Nut-Drain Fitting	Heyco 8463	4A0666-01	1	1	-							
12	Gasket - Cond. Coil	-	4A0455-01	1	1	1	1	1					
13	Divider Air UL	GS	3A1297-02	1	1	1	-						
			3A1297-01				1	1					
13a	T2 Screw	4x8, SS	7P32-0408	4	4	4	4	4					

Title: <b>B. Refrigeration System</b> Model: <b>FH2-SSB(-HD)</b>												
Index No.	Description	Material or Model Number	Part Number	Required Number								
				H-0	J-0 to J-2	L-5	M-5 to P-5	P-6 Q-5				
14	Pan - Evap. Drain	-	2A0200-01	1	1	-						
			2A0200-02			1	1	1				
15	Strap - Condensate Coil	-	3A0413-01	1	1	-						
			3A0413-03			1	1	1				
15a	Truss Head Screw	5x10, SS	7C32-0510	1	1	1	1	1				
16	Drier Bracket	-	4A0806-01	1	1	1	1	1				
16a	T2 Screw	4x8, SS	7P32-0408	2	2	2	2	2				
17	Expansion Valve	-	4A0922-01	1	1	1	1	1				
18	Exp. Valve Cover (A)	-	3A0372-01	1	1	1	1	1				
19	Exp. Valve Cover (B)	-	3A0372-02	1	1	1	1	1				
20	Coil - Condensate	-	2A1856-01			1	1	1				
21	Heater - Drain	-	4A2975-01					1				
21a	Nylon Tie	CV-200	8911-0200					2				
22	Thermistor Bracket (A)	ABS	433964-01	1	1	1	1	1				
22a	Truss Head Screw	4x16, SS	7C32-0416	2	2	2	2	2				
23	Thermistor Bracket (B)	ABS	433920-01	1	1	1	1	1				

## C. Control Panel Assembly FH2-SSB(-HD)

H-0, J-0, J-1, J-2, L-5, M-5, M-6, M-7, N-5, N-6, P-5, P-6, Q-5

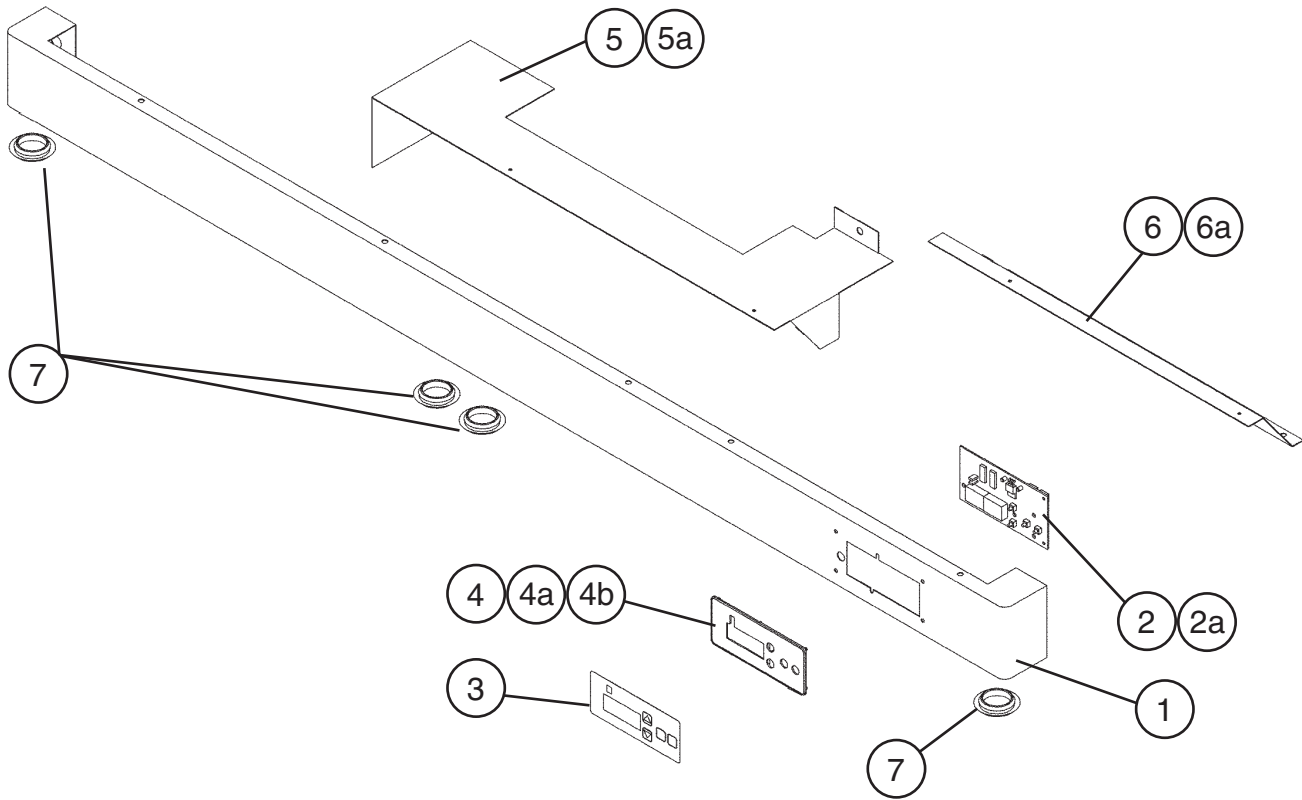

Title: C. Control Panel Assembly		Model: FH2-SSB(-HD)		Required Number										
Index No.	Description	Material or Model Number	Part Number	H-0 to J-2	L-5 to N-6	P-5 to Q-5								
1	Panel-Control (Painted)		3A1047G01	1	-									
			1A0626G01		1	-								
	Panel-Control	SS	1A0835-01			1								
2	Board-Display		2A0883-01	1	1	1								
2a	Ribbon Cable		4A1106-02	1	1	1								
3	Label-Display	PC	4A1558-02	1	1	-								
			3A2850-02			1								
4	Mount-Display Board	PC	3A0823-01	1	1	1								
4a	Palnut		4A1398-01	6	6	6								
4b	Nylon Screw		4A1397-01	4	4	4								
5	Control Panel Cover	GS	3A0559-01	1	1	1								
5a	T2 Screw	4x8, SS	7P32-0408	2	2	2								
6	Board Cover	GS	3A1046-01	1	1	1								
6a	T2 Screw	4x8, SS	7P32-0408	2	2	2								
7	Locking Hole Plug		4A0586-03	4	4	4								

**D. Body-Final**  
**FH2-SSB**  
 H-0, J-0, J-1, J-2

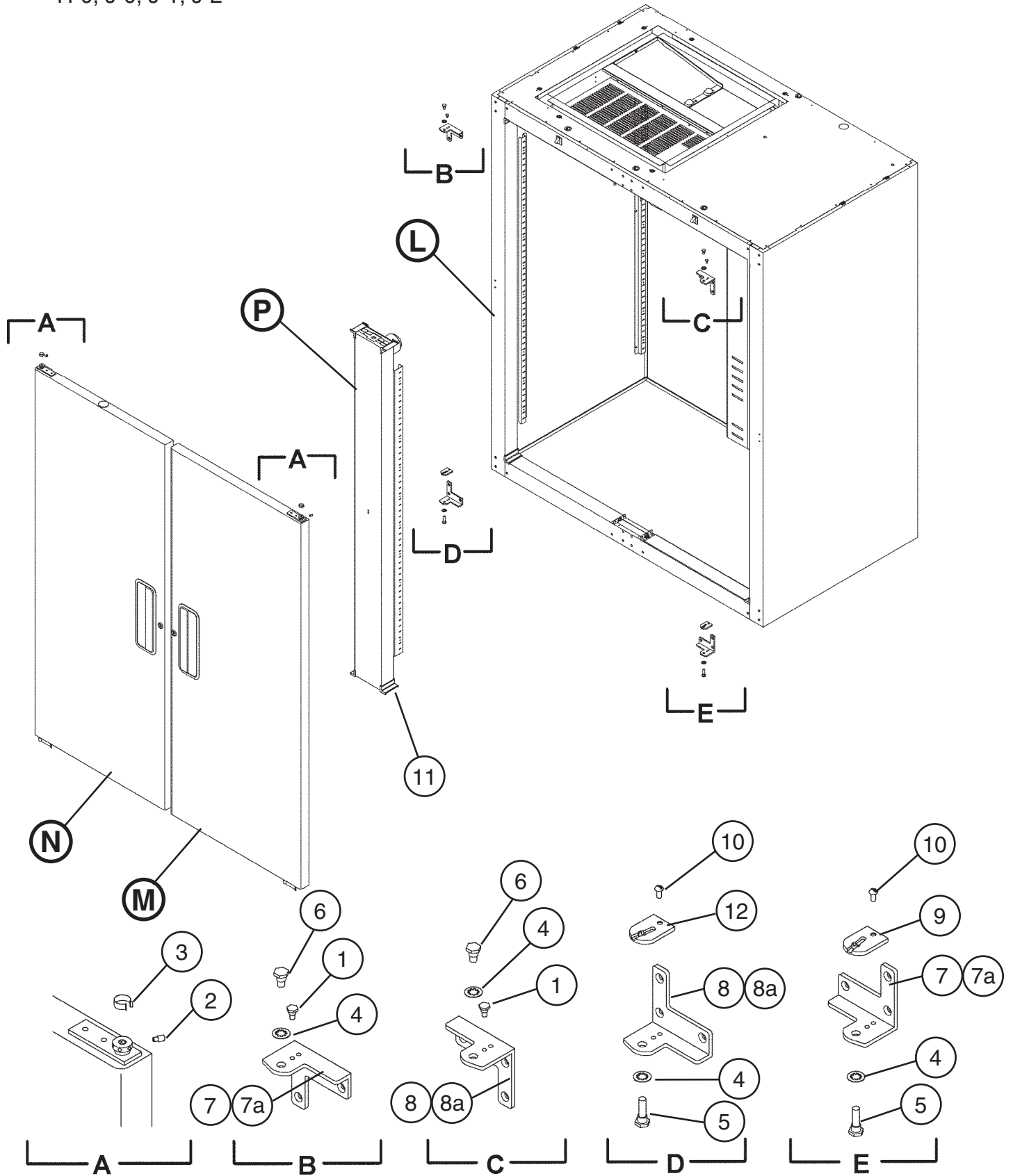

# D. Body-Final FH2-SSB

L-5, M-5, M-6, M-7, N-5, N-6, P-5, P-6, Q-5

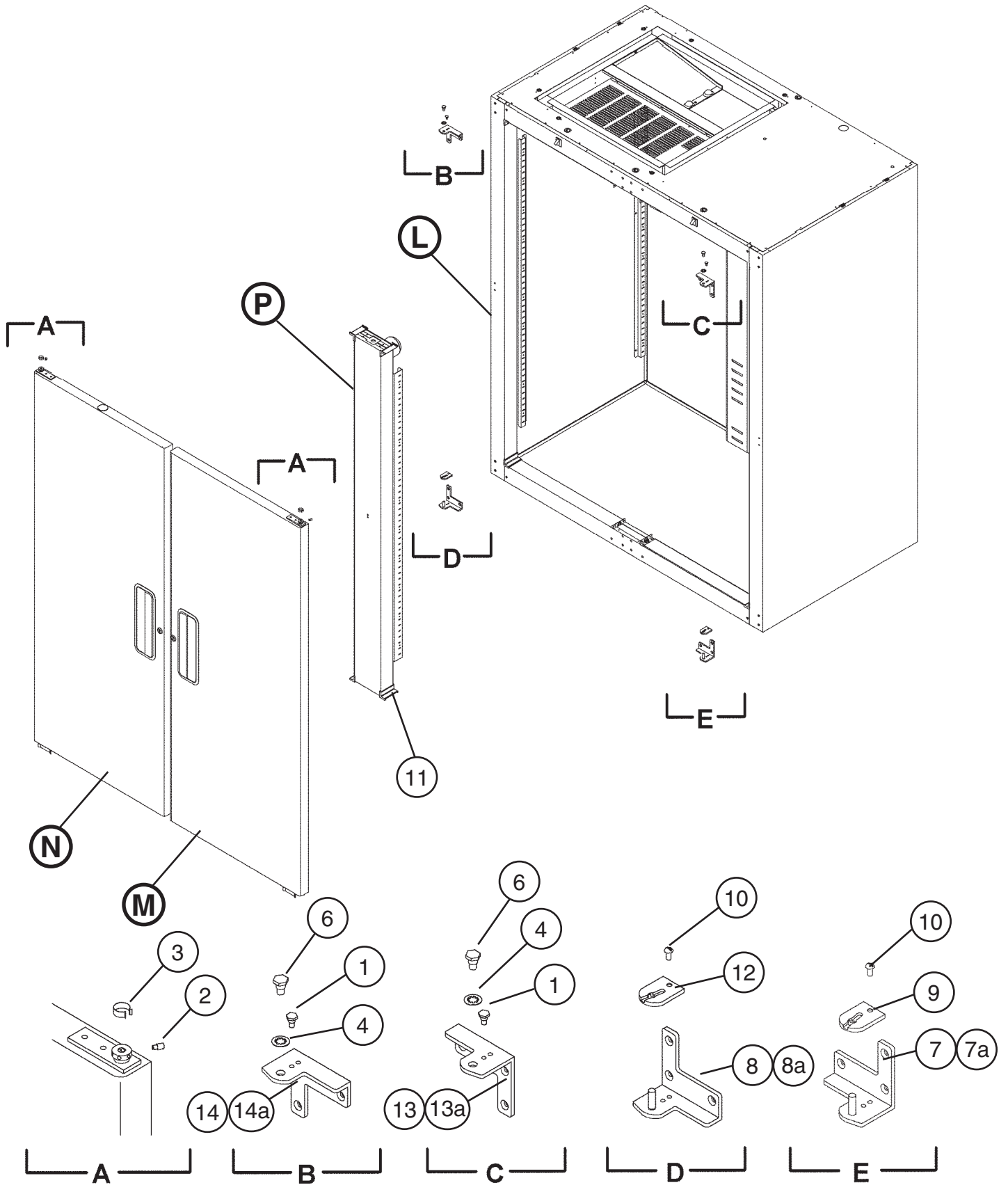

Title: <b>D. Body-Final</b> Model: <b>FH2-SSB</b>											
Index No.	Description	Material or Model Number	Part Number	Required Number							
				H-0 to J-2	L-5 to Q-5						
L	Body Prefinal		2A1207A01	1	-						
			2A1207A06		1						
M	Door Right		1A0318A01	1	-						
			1A0318A03		1						
N	Door Left		1A0318A02	1	-						
			1A0318A04		1						
P	Mullion Vertical		2A1289A01	1	-						
			2A1289A05		1						
1	Hinge Stop Pin		4A0444-01	2	-						
			4A2180-01		2						
2	Hinge Tension Screw		4A0446-01	2	2						
3	Hinge Bushing Cover		4A0445-01	2	2						
4	Hinge Lock Washer		4A0553-01	4	2						
5	Hinge Pivot Pin (Btm)		4A0443-01	2	-						
6	Hinge Pivot Pin (Top)		4A0442-01	2	-						
			4A2179-01		2						
7	Bracket Door Hinge (UL,LR)	Use latest for all aux. codes	3A0209-01	2	-						
	Bracket Door Hinge (LR)		3A1626-01		1						
7a	Countersunk Screw	5x20, SS	7C42-0520	6	3						
8	Bracket Door Hinge (LL,UR)	Use latest for all aux. codes	3A0215-01	2	-						
	Bracket Door Hinge (LL)		3A1627-01		1						
8a	Countersunk Screw	5x20, SS	7C42-0520	6	3						
9	Hinge Stop Plate (Right)		4A0441-01	1	1						
10	Screw Stop Plate		4A0483-01	2	2						
11	Cover Corner		3A0221-01	8	-						
			3A1751-01		8						
12	Hinge Stop Plate (Left)		4A0441-02	1	1						
13	Bracket Door Hinge (UR)		3A1580-01		1						
13a	Countersunk Screw	5x20, SS	7C42-0520		3						
14	Bracket Door Hinge (UL)		3A1581-01		1						
14a	Countersunk Screw	5x20, SS	7C42-0520		3						

**D. Body-Final**  
**FH2-SSB-HD**  
 J-1

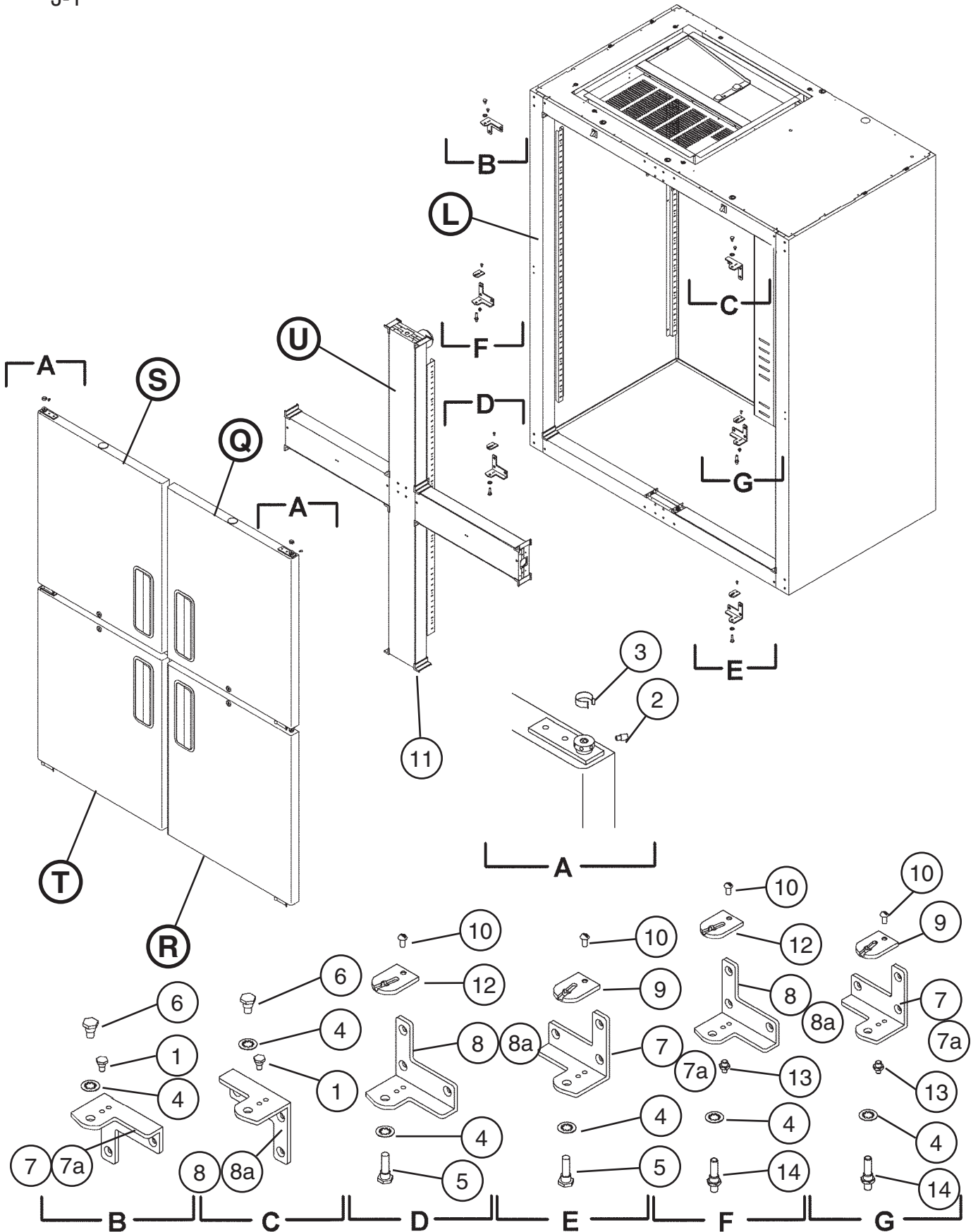

# D. Body-Final FH2-SSB-HD

L-5, M-6, M-7, N-6, P-5, P-6, Q-5

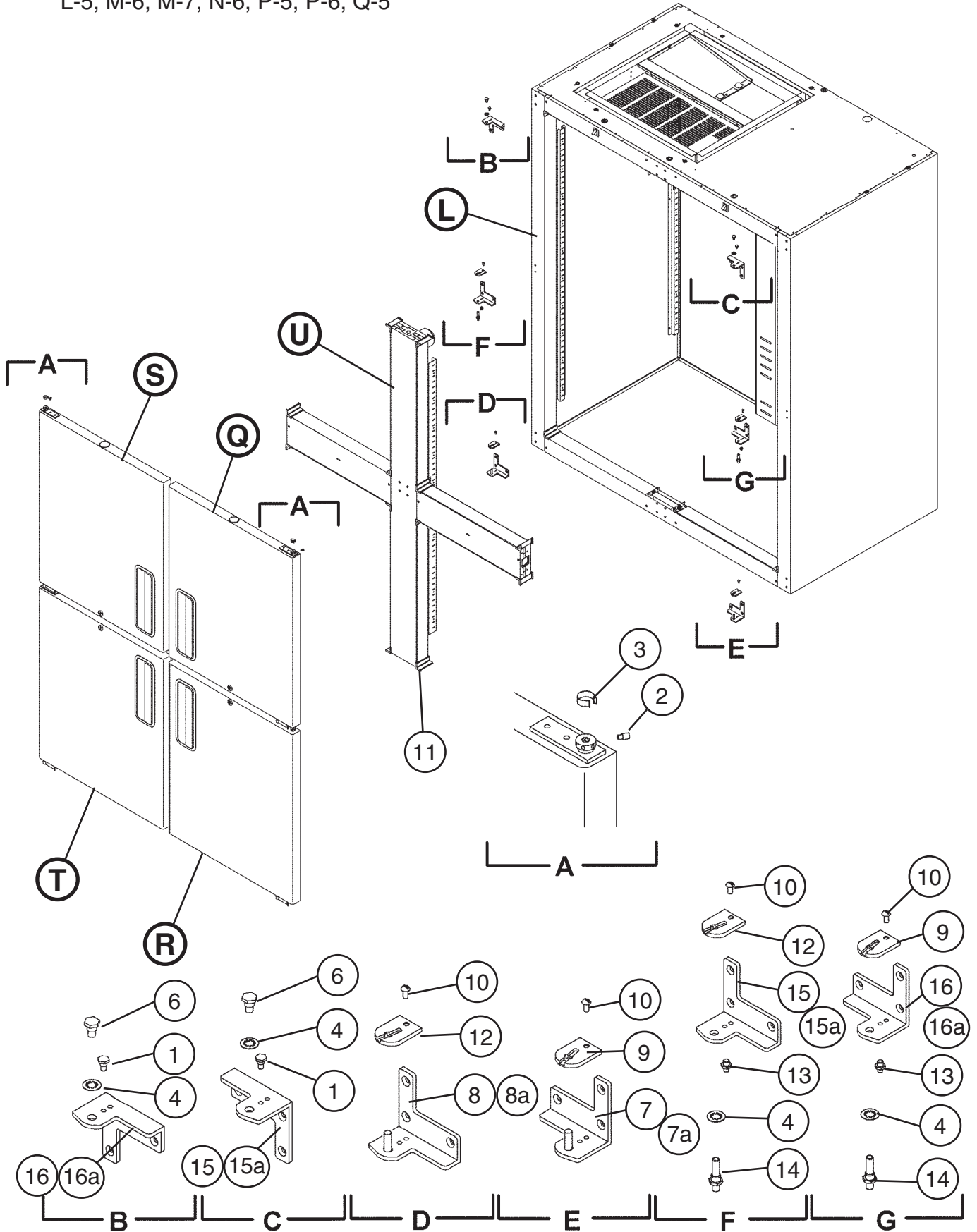



Title: **D. Body-Final** Model: **FH2-SSB-HD**

Index No.	Description	Material or Model Number	Part Number	Required Number							
				J-1	L-5	M-6 to Q-5					
L	Body Prefinal		2A1347A01	1	-						
			2A1347A04		1	1					
Q	Door Half (UR)		1A0326A01	1	1	-					
			1A0326A03			1					
R	Door Half (LR)		1A0324A01	1	1	-					
			1A0324A03			1					
S	Door Half (UL)		1A0324A02	1	1	-					
			1A0326A04			1					
T	Door Half (LL)		1A0326A02	1	1	-					
			1A0326A04			1					
U	Mullion-Cross		2A1350A01	1	-						
			2A1350A04		1	1					
1	Hinge Stop Pin		4A0444-01	2	-						
			4A2180-01		2	2					
2	Hinge Tension Screw		4A0446-01	4	4	4					
3	Hinge Bushing Cover		4A0445-01	4	4	4					
4	Hinge Lock Washer		4A0553-01	6	4	4					
5	Hinge Pivot Pin (Btm)		4A0443-01	2	-						
6	Hinge Pivot Pin (Top)		4A0442-01	2	-						
			4A2179-01		2	2					
7	Bracket Door Hinge (UL,LR)		3A0209-01	3	-						
	Bracket Door Hinge (LR)		3A1626-01		1	1					
7a	Countersunk Screw	5x20, SS	7C42-0520	9	3	3					
8	Bracket Door Hinge (LL,UR)		3A0215-01	3	-						
	Bracket Door Hinge (LL)		3A1627-01		1	1					
8a	Countersunk Screw	5x20, SS	7C42-0520	9	3	3					
9	Hinge Stop Plate (R)		4A0441-01	2	2	2					
10	Screw Stop Plate		4A0483-01	4	4	4					
11	Cover Corner		3A0221-01	16	-						
			3A1751-01		16	16					
12	Hinge Stop Plate (L)		4A0441-02	2	2	2					
13	Stop Pin		4A1734-01	2	2	2					
14	Pivot Pin		4A1735-01	2	2	2					
15	Bracket Door Hinge (UR)		3A1580-01		2	2					
15a	Countersunk Screw	5x20, SS	7C42-0520		6	6					
16	Bracket Door Hinge (UL)		3A1581-01		2	2					
16a	Countersunk Screw	5x20, SS	7C42-0520		6	6					

## E. Panel-Front Hinged Assembly

### FH2-SSB(-HD)

L-5, M-5, M-6, M-7, N-5, N-6, P-5, P-6, Q-5

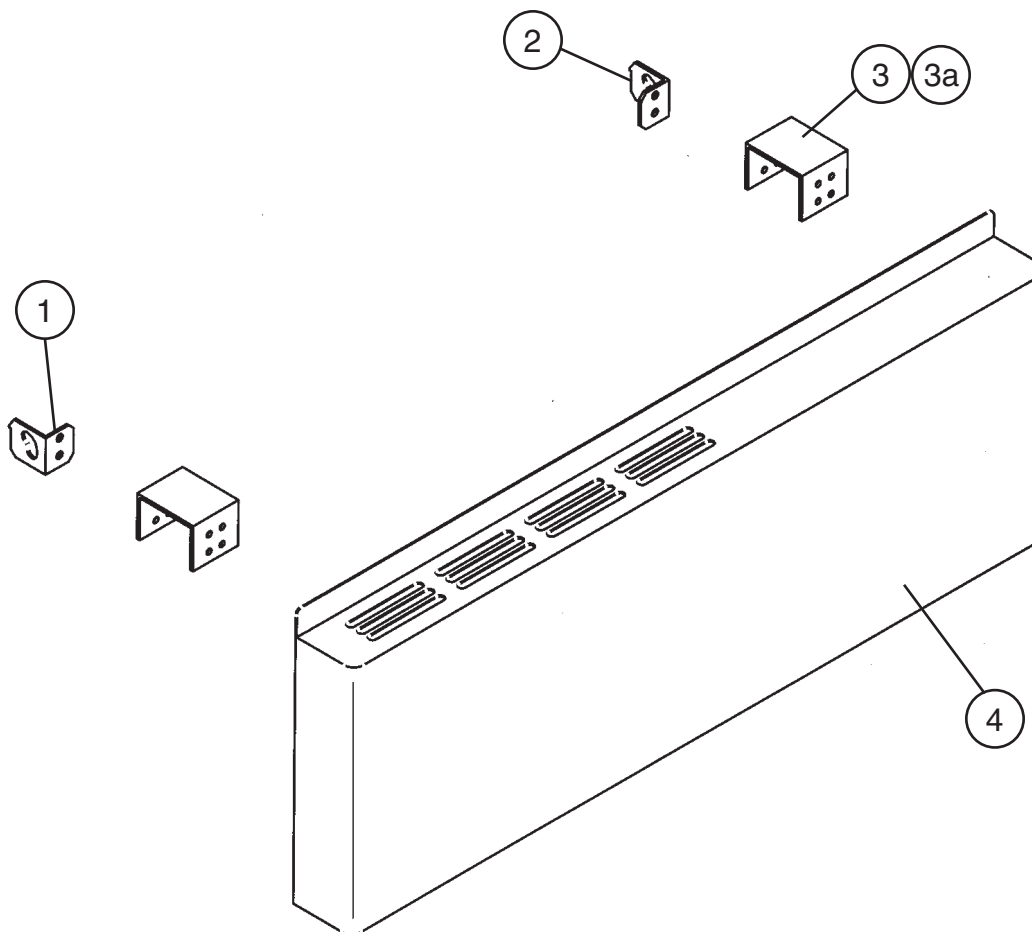

Title: E. Panel-Front Hinged Assembly Model: FH2-SSB(-HD)													
Index No.	Description	Material or Model Number	Part Number	Required Number									
				L-5 to Q-5									
1	Hinge – Front Panel (L)	GS	4A2153-01	1									
2	Hinge – Front Panel (R)	GS	4A2154-01	1									
3	Channel – Hinge	GS	4A2170-01	2									
3a	Truss Head Screw	5x8, SS	7C32-0508	4									
4	Panel – Front	SS	1A0624-02	1									

## F. Label Location FH2-SSB(-HD)

H-0, J-0, J-1, J-2, L-5, M-5, M-6, M-7, N-5, N-6, P-5, P-6, Q-5

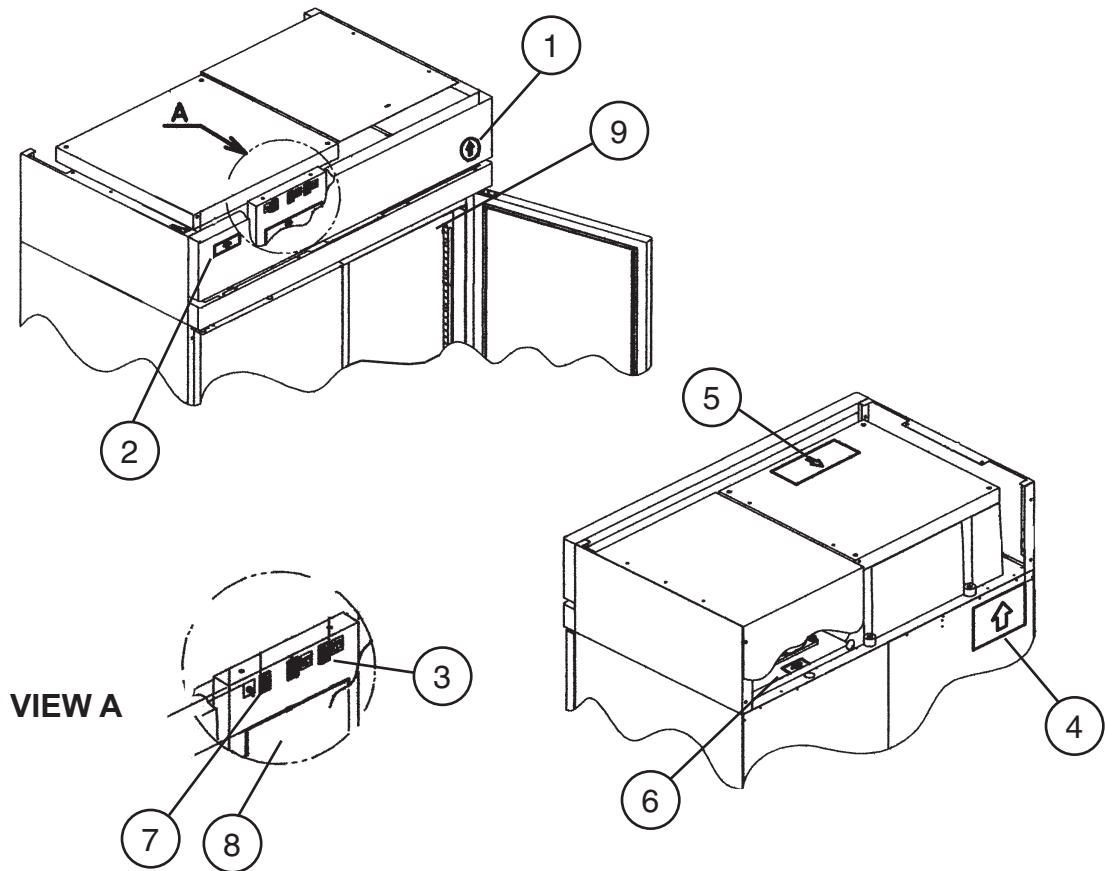

Title: F. Label-Location Model: FH2-SSB(-HD)				Required Number									
Index No.	Description	Material or Model Number	Part Number	H-0 to P-6	Q-5								
				1	Label-Penguin-HA(L)	-	4A0526-02	1	1				
2	Emblem-Hoshizaki	-	4A0560-01	1	1								
3	Label – Door Heater Switch	PVC FILM	4A1039-01	1	1								
4	Caution Label	PVC FILM	4A1931-01	1	1								
5	Wiring Diagram	PVC FILM	2A2343-01	1	1								
6	Label – R404A	-	4A0960-01	1	1								
7	Label – Power	-	4A0522-01	1	1								
8	Label – Display Info	-	3A1413-01	1	1								
9	Cover-Nameplate	-	4A3727-01		1								

## G. Evaporator Fan Shroud Assembly FH2-SSB(-HD)

H-0, J-0, J-1, J-2, L-5, M-5, M-6, M-7, N-5, N-6, P-5, P-6, Q-5

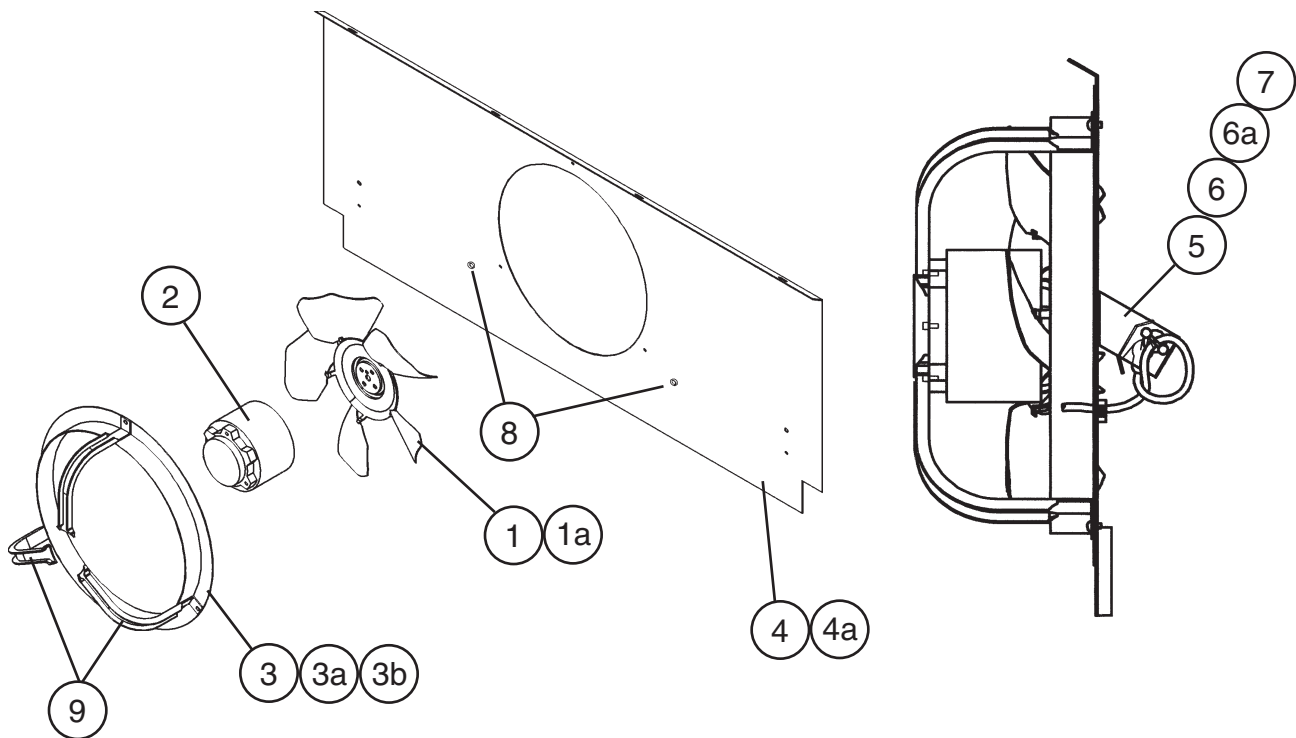

Title: G. Evaporator Fan Shroud Assembly Model: FH2-SSB(-HD)														
Index No.	Description	Material or Model Number	Part Number	Required Number										
				H-0 to J-2	L-5 to P-5	P-6 Q-5								
1	Blade-Fan Pusher	Air Drive AD9CCW30UBA	3A0438-01	1	1	1								
1a	Hex Nut		4A1345-01	1	1	1								
2	Motor-Evap Fan	Morri PSC4BE9BEA1	4A0413-01	1	1	1								
3	Orifice - Evap Fan	SS	4A0412-01	1	1	1								
3a	T2 Screw	4x8, SS	7P32-0408	3	3	3								
3b	Lock Washer	-	4A0459-01		3	3								
4	Shroud - Evap	SS	1A0100-01	1	1	-								
			1A0100-02			1								
4a	Truss Head Screw	4x16, SS	7C32-0416	4	4	4								
5	Bracket - Heater Supply	-	3A3243-01			1								
6	Heater - Glass Tube	-	3A2335-02			1								
6a	T2 Screw	4x8, SS	7P32-0408			2								
7	Wire Tie (Twist)	-	4A1223-01			4								
8	Bushing	-	428394-02			2								
9	Nylon Tie	CV-100	8911-0100			4								

## H. Evaporator Assembly FH2-SSB(-HD)

H-0, J-0, J-1, J-2, L-5, M-5, M-6, M-7, N-5, N-6, P-5, P-6, Q-5

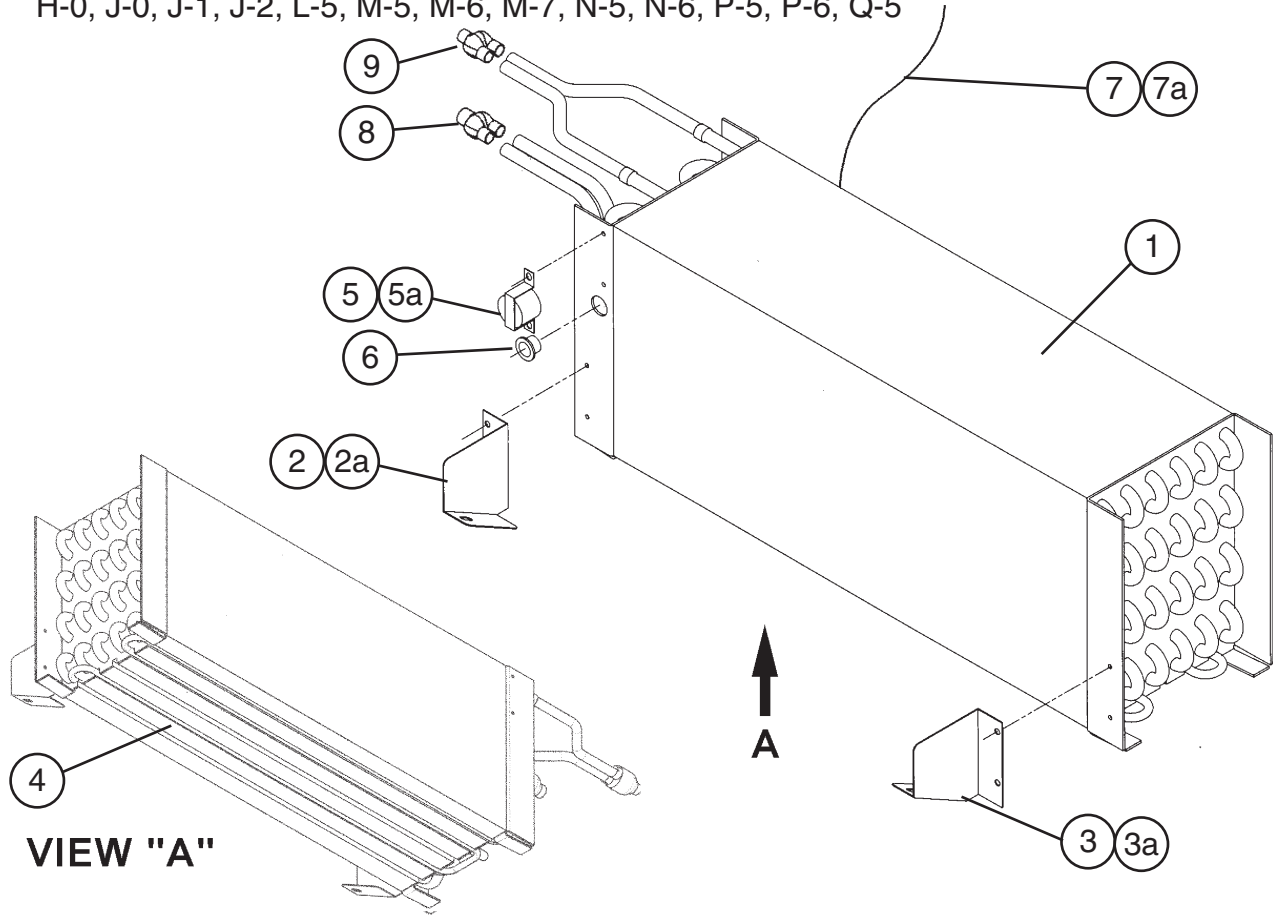

These additional parts added to FH2-SSB(-HD) Evaporator Assembly at aux. code M-6

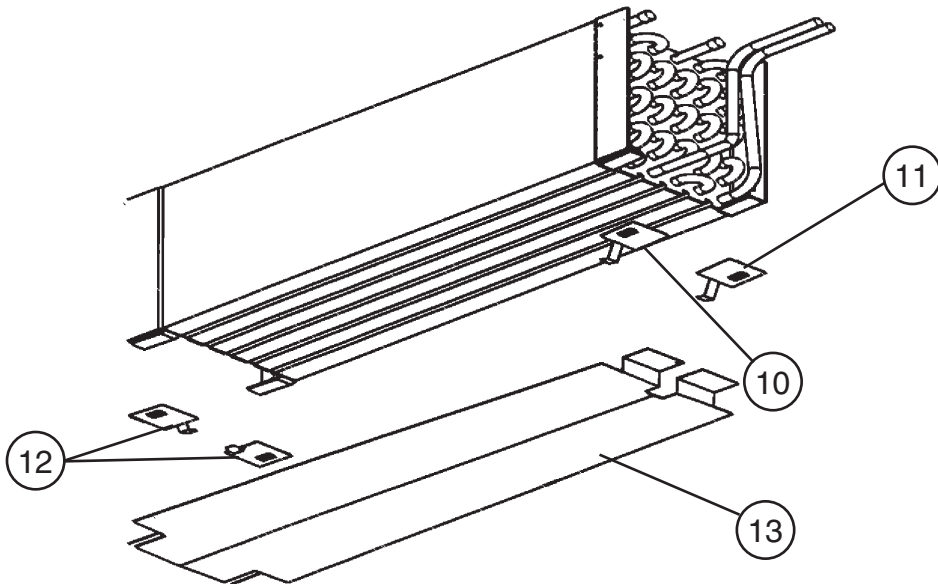

Title: <b>H. Evaporator Assembly</b> Model: <b>FH2-SSB(-HD)</b>												
Index No.	Description	Material or Model Number	Part Number	Required Number								
				H-0 to M-5	M-6 to P-5	P-6 Q-5						
1	Evaporator	-	2A0636-01	1	1	1						
2	Bracket-Evap Shroud(R)	SS	4A0545-01	1	1	-						
2a	T2 Screw	4x8, SS	7P32-0408	2	2	-						
3	Bracket-Evap Shroud(L)	SS	4A0548-01	1	1	-						
3a	T2 Screw	4x8, SS	7P32-0408	2	2	-						
4	Heater – Defrost	-	3A0591-01	1	1	1						
5	Thermostat – Defrost	-	4A0954-02	1	1	1						
5a	T2 Screw	4x8, SS	7P32-0408	2	2	2						
6	Bushing	-	420470-01	1	1	1						
7	Thermistor – Defrost	-	4A1428-01	1	1	1						
7a	Thermistor – Clip	-	320418-01	1	1	1						
8	“Y” Joint	-	4A1687-03	1	1	1						
9	“Y” Joint	-	4A1687-02	1	1	1						
10	Clip – Support Evap (A)	-	4A2826-01		1	1						
11	Clip – Support Evap (B)	-	4A2827-01		1	1						
12	Clip – Support Evap (C)	-	4A2828-01		2	2						
13	Shield – Heat	-	3A1853G01		1	1						

### Installation Instructions for Parts 10, 11, 12, & 13

1. The original heat shield must be removed. This can be done by lifting the evaporator up and sliding the heat shield out.
2. The new heat shield (part #13) is then installed in the rotocast drain pan.
3. The clips are then slid onto the end plate on the evaporator. Support clips (part #12) are installed onto the hairpin end of the evaporator as shown in the illustration.
4. The other support clips (parts #10 and #11) are installed on the return bend end (same side as inlet and outlet tubes) as shown in the illustration.

NOTE: All clips are shown in the illustration in the correct orientation for installation. The parts are slid onto the evaporator bracket using the tab on the support clip.

## J. Condenser Assembly

### FH2-SSB(-HD)

H-0, J-0, J-1, J-2

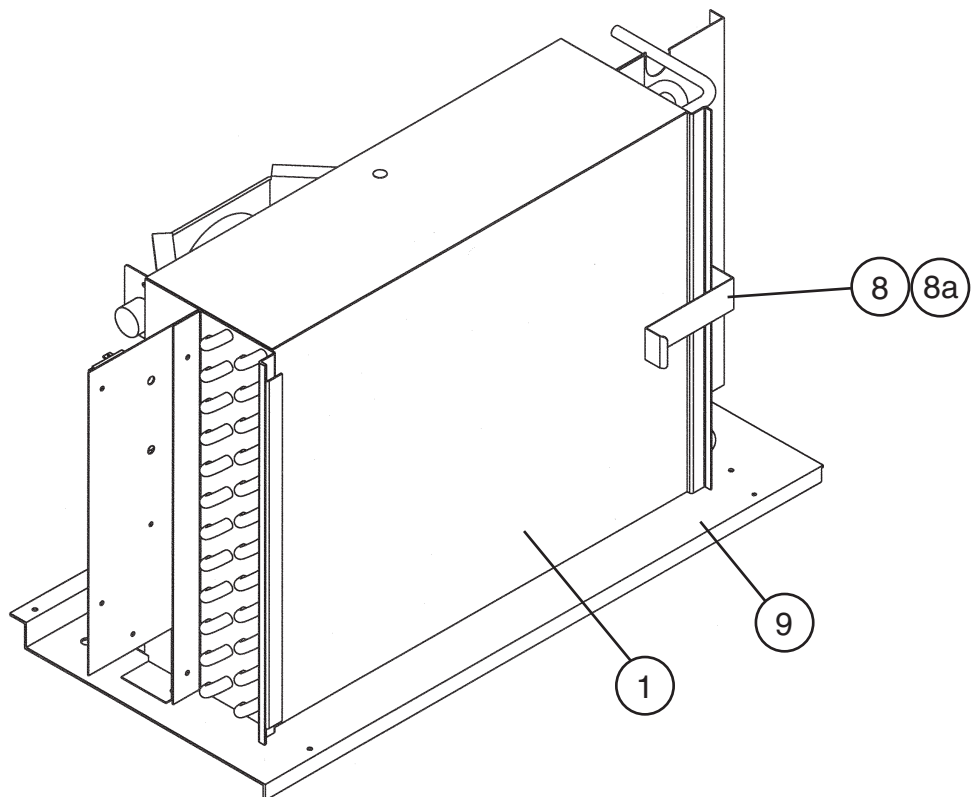
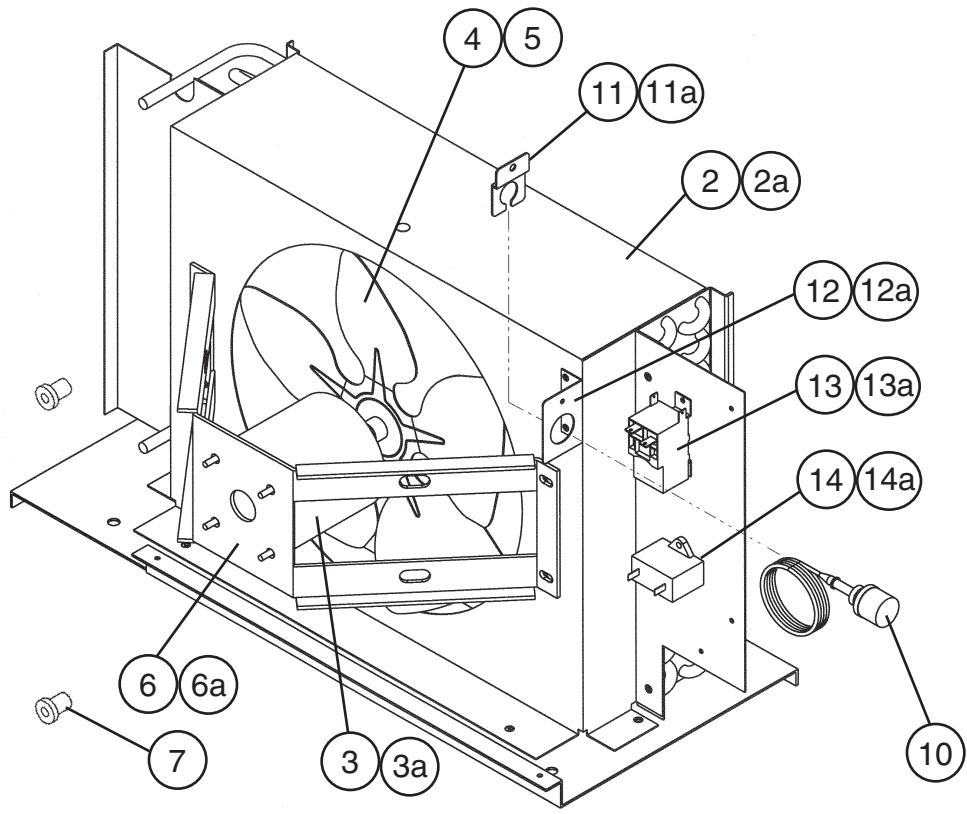

# J. Condenser Assembly FH2-SSB(-HD)

L-5, M-5, M-6, M-7, N-5, N-6, P-5, P-6, Q-5

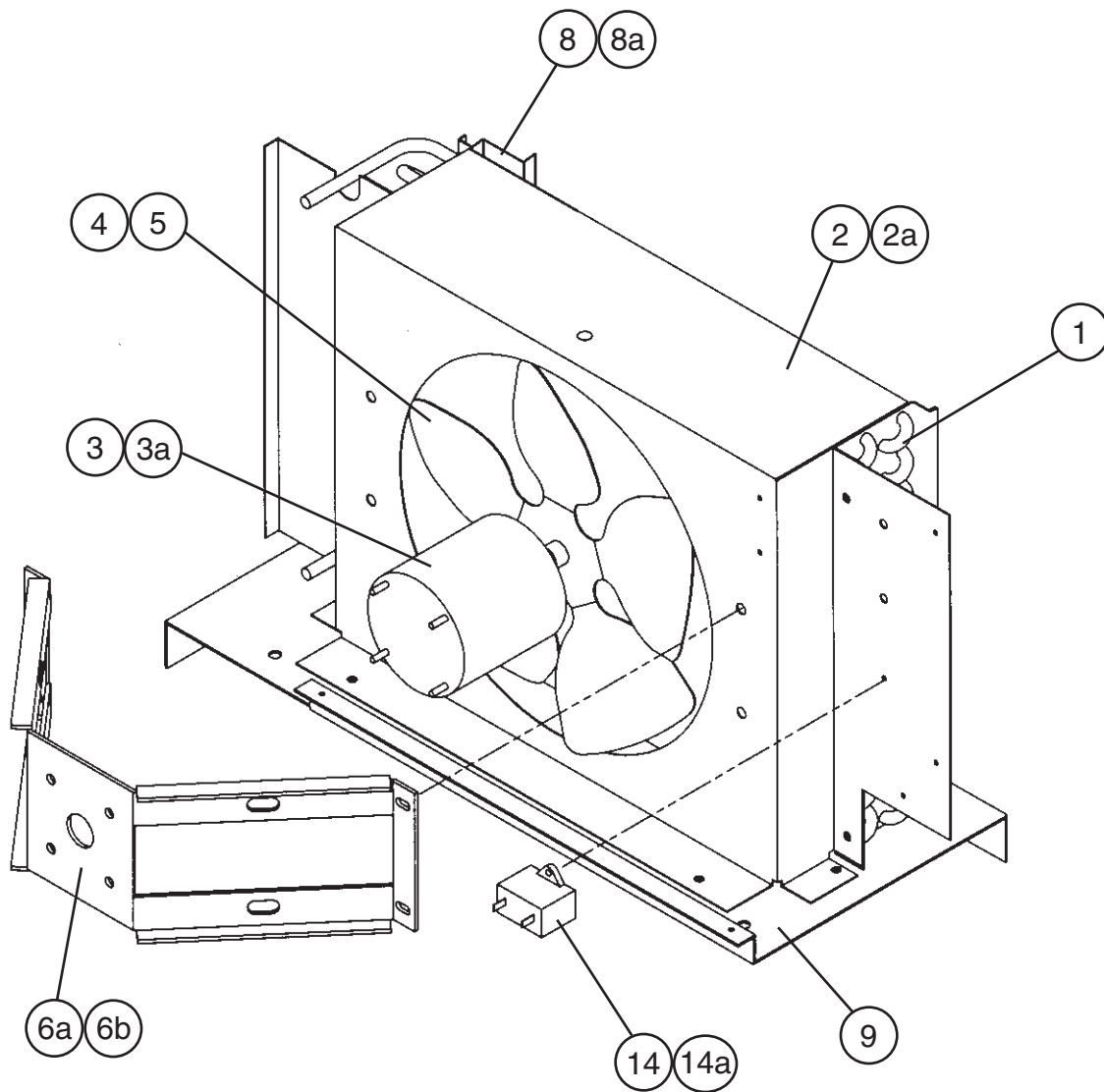



Title: <b>J. Condenser Assembly</b> Model: <b>FH2-SSB(-HD)</b>													
Index No.	Description	Material or Model Number	Part Number	Required Number									
				H-0	J-0	J-1	J-2	L-5 to P-5	P-6 Q-5				
1	Condenser	973803	2A0638-01	1	1	1	1	1	1				
2	Shroud Condenser	GS	2A0639-02	1	-								
			2A1491-01		1	1	1	1	1				
2a	T2 Screw	4x12, SS	7P32-0412	8	8	8	8	8	8				
3	Fan Motor	SP-B16EM1	4A0815-01	1	-								
		U90B1 FASCO	440911-01		1	1	1	1	-				
		GE 5KCP84DFK148S	4A3158-01							1			
3a	Self Locking Nut	4x8	7N2110832		4	4	4	4	4				
4	Fan Blade (Puller)	Air Drive AD9CW38UBA	3A0608-01	1	-								
		Air Drive AD10CCW32	4A1865-01		1	1	1	1	1				
5	Hex Nut	1/4"-20 Zinc	4A1345-01	1	1	1	1	-					
6	Bracket-Condenser Fan	GS	3A0457-01	1	-								
			3A1298-01		1	1	-						
			2A1668-01				1	1	1				
6a	Hex Bolt	6x25		4	-								
	Truss Head Screw	5x12, SS	7C32-0512		4	4	4	4	4				
7	Well Nut	D1420	4A0422-01	2	-								
8	Retainer-Filter	GS	4A0929-01	1	1	1	1	-					
			4A2138-01						1	1			
8a	T2 Screw	4x8, SS	7P32-0408	2	2	2	2	2	2				
9	Base - Condenser	-	2A1217-01	1	1	1	1	1	1				
10	Switch-Pressure	20PS025WT 450K320K	3A0335-03	1	1	-							
		D94V 20PSO24W T500K330K	3A0335-02			1	1	Shown on assembly B					
11	Bracket-Press Switch	GS	4A0552-01	1	1	1	1	-					
11a	T2 Screw	4x8	7P31-0408	1	1	1	1	-					
12	Bracket-Press Switch (B)	GS	4A1565-01	1	1	1	1	-					
12a	T2 Screw	4x8	7P31-0408	2	2	2	2	-					
13	Thermostat- Defrost Backup	Ranco	4A1344-01	1	1	1	1	-					
13a	T2 Screw	4x8	7P31-0408	2	2	2	2	-					
14	Capacitor-Fan	5MFD, 250VAC	443192-02	1	1	1	1	1	1				
14a	T2 Screw	4x8, SS	7P32-0408	1	1	1	1	1	1				

# K. Control Box Assembly

## FH2-SSB

H-0, J-0, J-1, J-2, L-5, M-5, M-6, M-7, N-5, N-6, P-5, P-6, Q-5

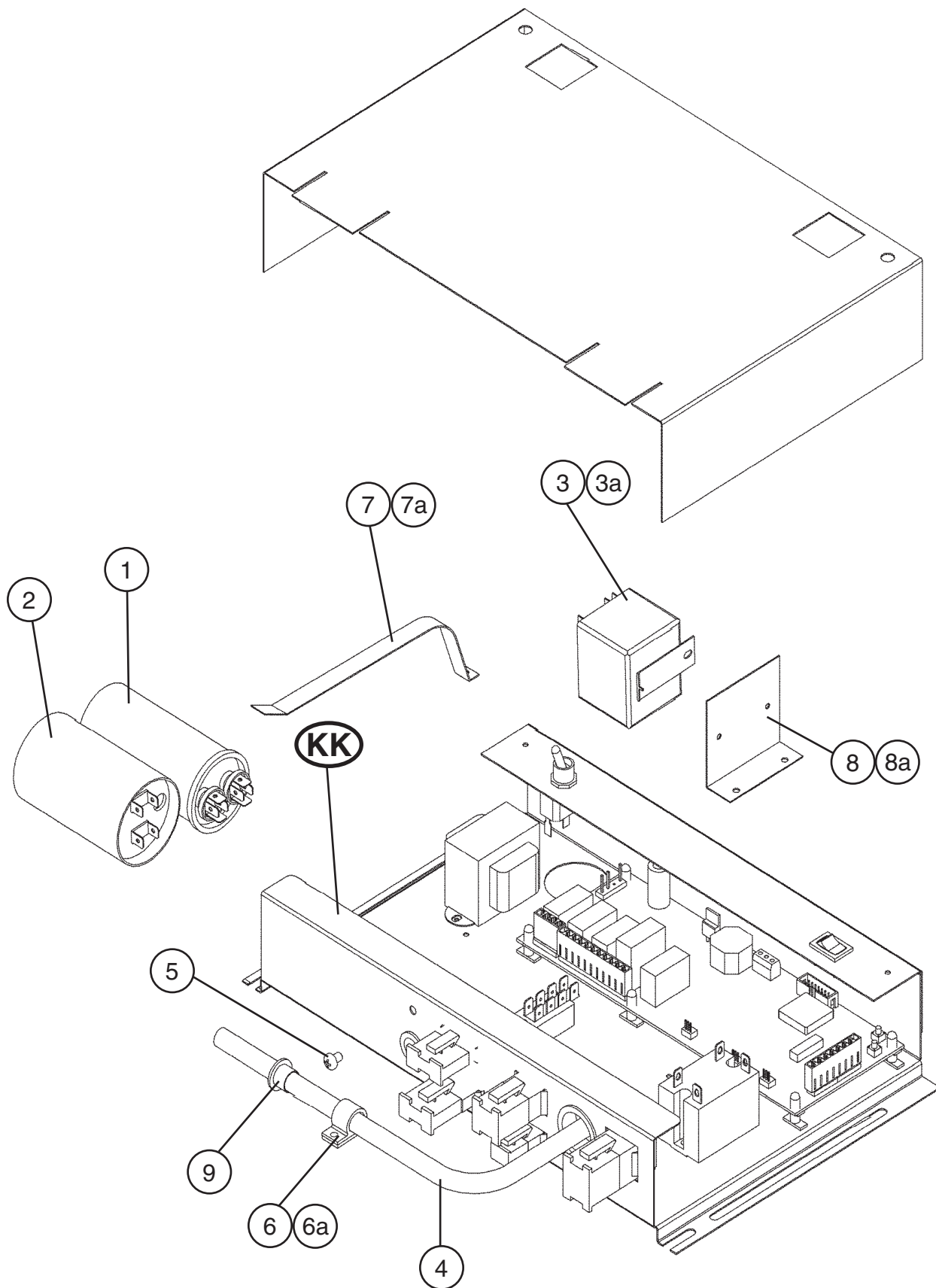

Title: <b>K. Control Box Assembly</b> Model: <b>FH2-SSB</b>											
Index No.	Description	Material or Model Number	Part Number	Required Number							
				H-0	J-0 to J-2	L-5	M-5 to Q-5				
KK	Common Control Box	-	2A1147A01	1	1	1	1				
1	Capacitor-Run	25MFD, 370VAC	439943-02	1	1	1	-				
			3A2005-06				1				
2	Capacitor-Start	88-106MFD, 330VAC	3A0076-07	1	1	1	1				
3	Starter	3ARR3CT3S5	434172-01	1	-						
			4A1107-13		1	1	1				
3a	T2 Screw	4x8, SS	7P32-0408	1	1	1	1				
4	Power Cordset	-	4A1543-01	1	1	Shown on assembly A					
5	Grounding Screw	M5	433304-02	1	1	1	1				
6	Wire Clamp	-	4A0809-02	1	1	-					
6a	T2 Screw	4x8, SS	7P32-0408	1	2	-					
7	Strap	GS	434580-14	1	1	1	1				
7a	T2 Screw	4x8, SS	7P32-0408	1	1	1	1				
8	Mount Bracket	GS	4A0809-03	1	1	-					
			4A1876-01			1	1				
8a	T2 Screw	4x8, SS	7P32-0408	2	2	2	2				
9	Bushing		420470-01	1	1	-					

# K. Control Box Assembly

## FH2-SSB-HD

J-1, L-5, M-6, M-7, N-6, P-5, P-6, Q-5

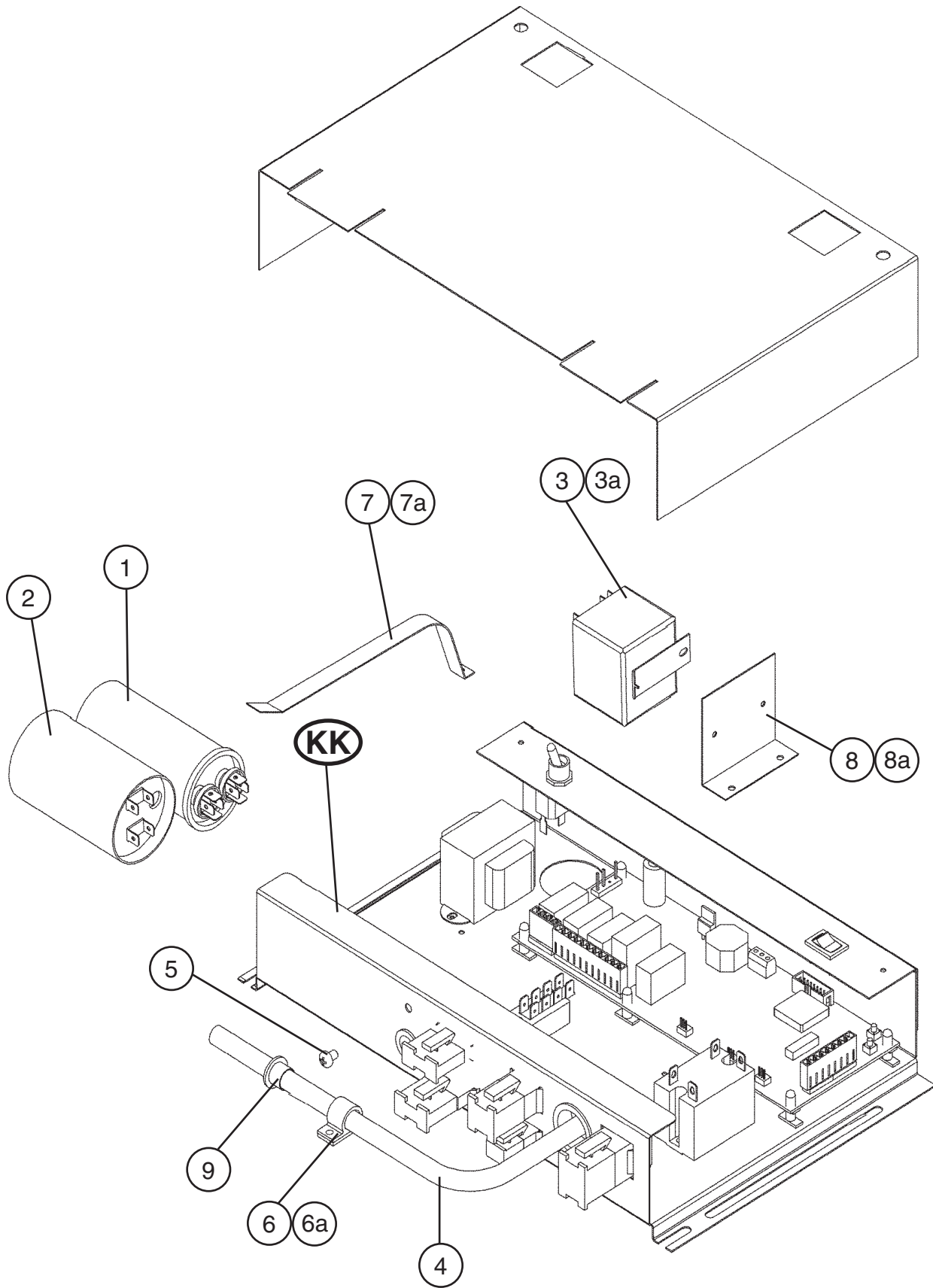

Title: **K. Control Box Assembly** Model: **FH2-SSB-HD**

Index No.	Description	Material or Model Number	Part Number	Required Number									
				J-1	L-5	M-6 to Q-5							
KK	Common Control Box	-	2A1147A01	1	1	1							
1	Capacitor-Run	25MFD, 370VAC	439943-02	1	1	-							
			3A2005-06			1							
2	Capacitor-Start	88-106MFD, 330VAC	3A0076-07	1	1	1							
3	Starter	3ARR3CT3S5	434172-01	1	-								
		3ARR3KC24S5	4A1107-13		1	1							
3a	T2 Screw	4x8, SS	7P32-0408	1	1	1							
4	Power Cordset	-	4A1543-01	1	1	Shown on assembly A							
5	Grounding Screw	M5	433304-02	1	1	1							
6	Wire Clamp	-	4A0809-02	1	1	-							
6a	T2 Screw	4x8, SS	7P32-0408	1	1	-							
7	Strap	GS	434580-14	1	1	1							
7a	T2 Screw	4x8, SS	7P32-0408	1	1	1							
8	Mount Bracket	GS	4A1876-01	1	1	1							
8a	T2 Screw	4x8, SS	7P32-0408	2	2	2							
9	Bushing		420470-01	1	1	-							

# KK. Common Control Box FH2-SSB(-HD)

H-0, J-0, J-1, J-2, L-5, M-5, M-6, M-7, N-5, N-6, P-5, P-6, Q-5

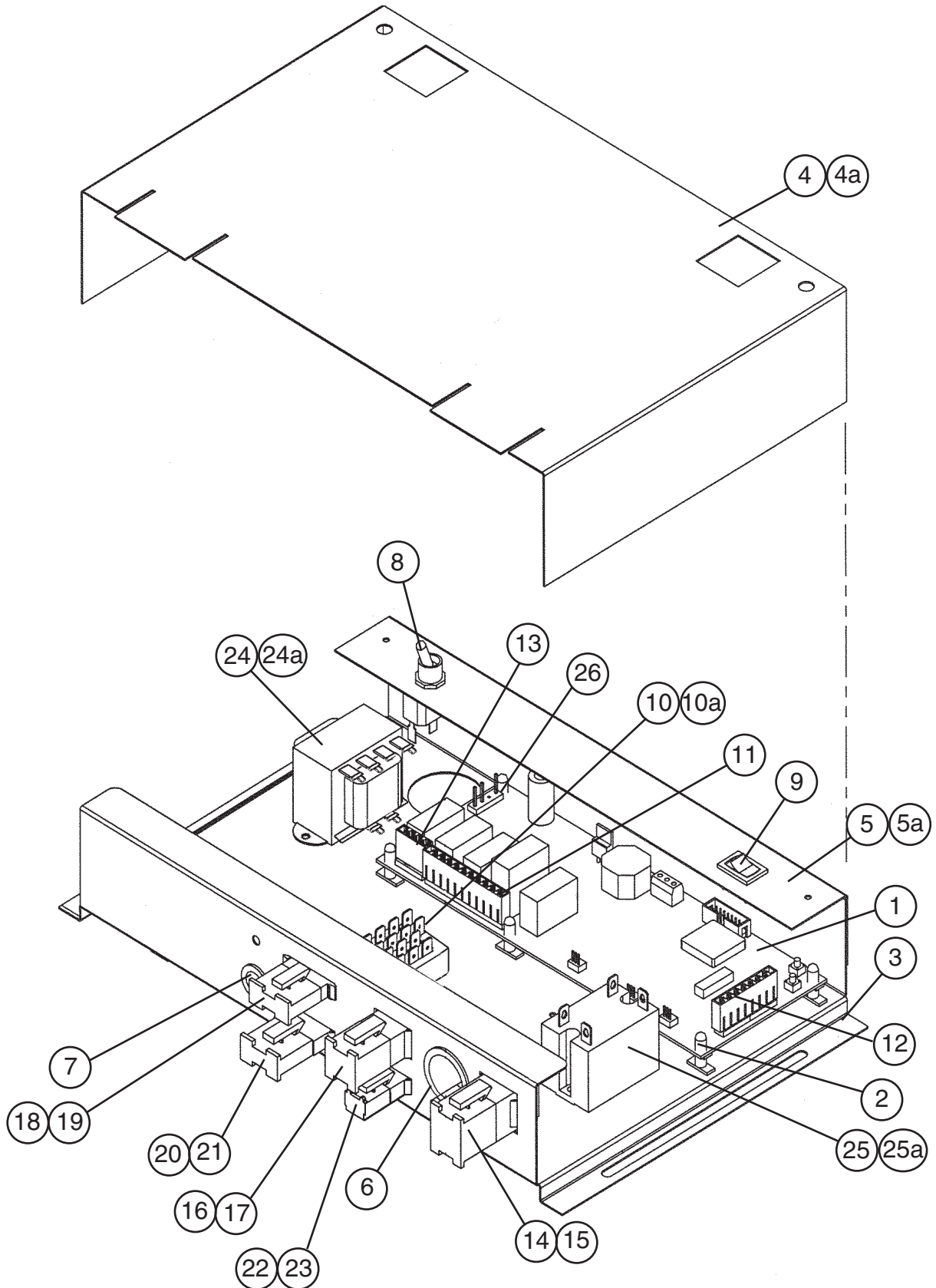

Title: **KK. Common Control Box** Model: **FH2-SSB(-HD)**

Index No.	Description	Material or Model Number	Part Number	Required Number									
				H-0 to J-2	L-5 to M-6	M-7 to P-5	P-6 Q-5						
1	Board – Control	Use latest for all aux. codes	2A0882-01	1	-								
			2A1854-01		1	1	-						
			2A2862-21				1						
2	Board Support	NYLON	4A0336-03	6	6	6	6						
3	Base – Control Box	GS	2A1146-01	1	1	1	1						
4	Cover – Control Box	GS	2A1031-01	1	1	1	1						
4a	T2 Screw	4x8, SS	7P32-0408	2	2	2	2						
5	Switch – Bracket	GS	2A1032-01	1	-								
			2A1032-02		1	1	1						
5a	T2 Screw	4x8, SS	7P32-0408	2	2	2	2						
6	Bushing	SB-1093-15	420470-03	1	1	1	1						
7	Bushing	SB-625-8	420470-01	1	1	1	1						
8	Switch – Toggle	7802K21	4A0424-01	1	1	1	1						
9	Switch – Rocker	1801 1102	4A0418-01	1	1	1	1						
10	Terminal Block	ESB1-6-8	4A1540-01	1	1	-							
		ESB2-323-424	4A2619-01			1	1						
10a	Tapping Screw	3x8	431415-01	1	1	1	1						
11	Board Connector	5198-10	434003-05	1	1	1	1						
12	Board Connector	5198-07	434003-07	1	1	1	1						
13	Board Connector	5198-03	434003-11	1	1	1	1						
14	Plug Housing (9 Pin)	3191-09P	412832-02	1	1	1	1						
15	Receptacle Housing (9 Pin)	3191-09R1	412831-02	1	1	1	1						
16	Plug Housing (6 Pin)	3191-06P	412832-03	1	1	1	1						
17	Receptacle Housing (6 Pin)	3191-06R1	412831-03	1	1	1	1						
18	Plug Housing	03-12-2036	4A0425-01	1	1	1	1						
19	Receptacle Housing	03-12-1035	4A0426-01	1	1	1	1						
20	Receptacle Housing (4 Pin)	3191-04R1	412831-05	1	1	1	1						
21	Plug Housing (4 Pin)	3191-04P	412832-05	1	1	1	1						
22	Receptacle Housing (2 Pin)	3191-02R1	412831-07	1	1	1	1						
23	Plug Housing (2 Pin)	3191-02P	412832-07	1	1	1	1						
24	Transformer	26D285H	3A0172-01	1	-								
		F4-10	3A1759-01		1	1	1						
24a	Tapping Screw	3x8	431415-01	2	2	2	2						
25	Compressor Relay	HE1aN-AC120V	4A1307-01	1	1	1	1						
25a	Tapping Screw	3x8	431415-01	2	2	2	2						
26	Board Connector	5198-03	434003-09		1	1	1						

## L. Body-Prefinal FH2-SSB(-HD)

H-0, J-0, J-1, J-2, L-5, M-5, M-6, M-7, N-5, N-6, P-5, P-6, Q-5

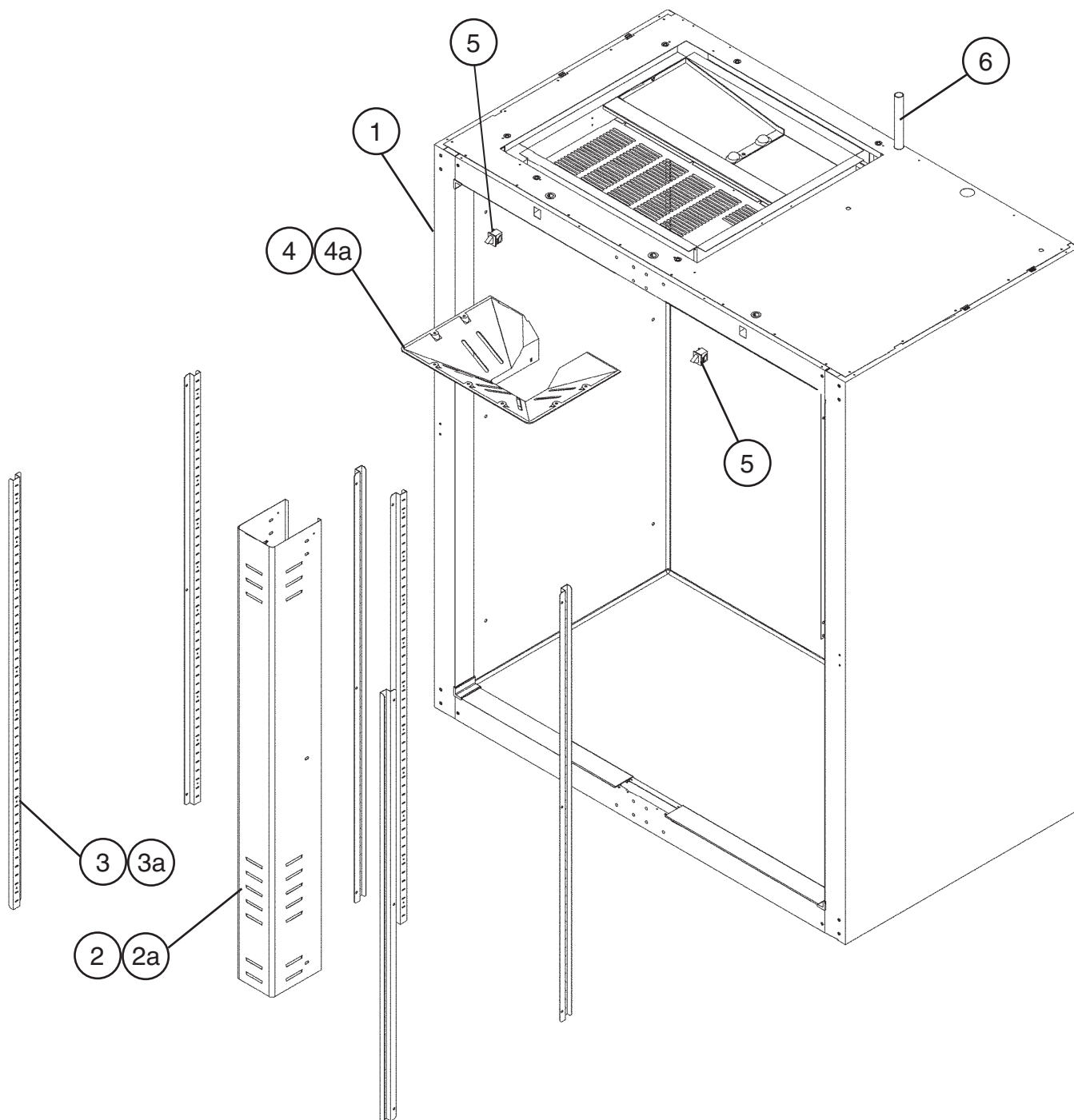



Title: L. Body-Prefinal Model: FH2-SSB(-HD)												
Index No.	Description	Material or Model Number	Part Number	Required Number								
				H-0	J-0 J-1	J-2	L-5 to P-6	Q-5				
1	Cabinet Prefoam	<b>FH2-SSB</b>	2A0706G01	1	1	1	-					
			2A0706G06				1					
		<b>FH2-SSB-HD</b>	2A1346G01		1	1	-					
			2A1346G04				1					
2	Distributor-Air (Bottom)	SS	1A0143-01	1	1	1	-					
			1A0512-01				1	-				
			1A0985-01					1				
2a	T2 Screw	4x10, SS	7P32-0410	2	2	2	2					
3	Pilaster	SS	3A0145-01	6	6	6	6					
3a	Truss Head Screw	5x10,SS	7C32-0510	18	18	18	18					
4	Distributor-Air Top Assembly	ABS	1A0152-02	1	1	1	-					
4a	T2 Screw	4x8, SS	7P32-0408	7	7	7	-					
5	Switch Door	<b>FH2-SSB</b> Nylon	4A0487-01	2	-							
			3A1386-01		2	-						
			3A1826-01			2	2					
		<b>FH2-SSB-HD</b> Nylon	3A1386-01		4	4	-					
			3A1826-01				4					
6	Vinyl Hose	L=1700	7716-0913	1	-							
			773013812		1	1	1					

# M. Door-Right FH2-SSB

H-0, J-0, J-1, J-2, L-5, M-5, M-6, M-7, N-5, N-6, P-5, P-6, Q-5

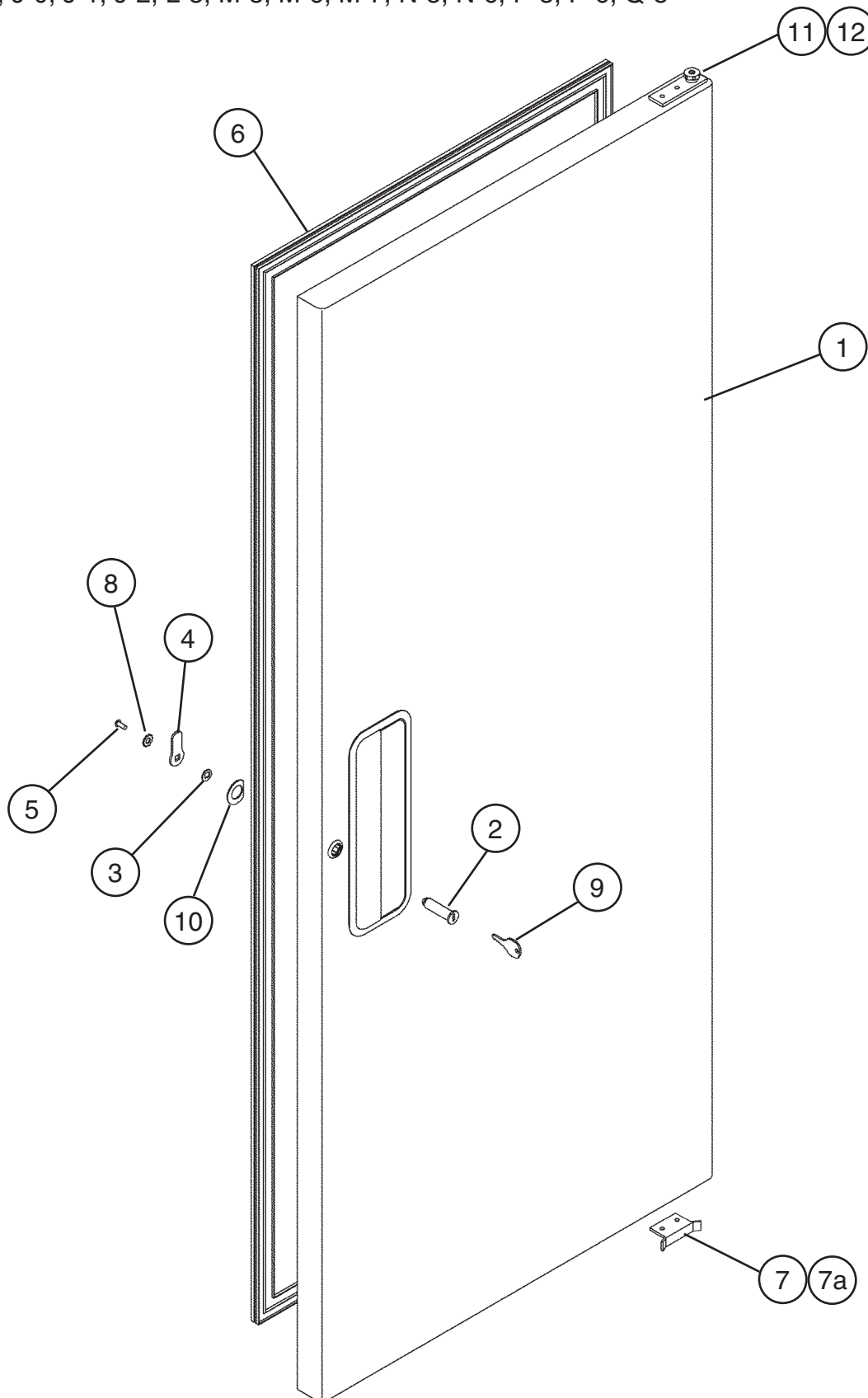

Title: <b>M. Door-Right</b> Model: <b>FH2-SSB</b>											
Index No.	Description	Material or Model Number	Part Number	Required Number							
				H-0	J-0 to J-2	L-5 to M-7	N-5 to Q-5				
1	Door-Prefoam (R)	-	1A0317G01	1	1	1	-				
			1A0317G03				1				
2	Lock-Tumbler	M4-5813-001	4A0462-01	1	1	1	1				
3	Lock-Stop Washer	M5-8060-103	4A0458-01	1	1	1	1				
4	Cam-Door Lock	P.S	4A0228-01	1	1	1	1				
5	Lock-Screw	SS	4A0461-01	1	1	1	1				
6	Gasket-Door	Jarrow #P-2209 244A Gray	3A0273-01	1	1	1	1				
7	Stop-Door	SS	4A0351-01	1	1	-					
7a	Screw-Countersunk	5X20, SS	7C42-0520	2	-						
	Truss Head Screw	5X25, SS	7C32-0525		2	-					
8	Lock-Washer	SS	4A0459-01	1	1	1	1				
9	Lock-Key	M5-0680-111	4A0460-01	1	1	1	1				
10	Washer-Door Lock	SS	4A0670-01	1	1	1	1				
11	Hinge-Spring		4A3312-01	1	1	1	1				
12	Hinge-Spring Cart		4A0438-01	1	1	1	1				

# N. Door-Left FH2-SSB

H-0, J-0, J-1, J-2, L-5, M-5, M-6, M-7, N-5, N-6, P-5, P-6, Q-5

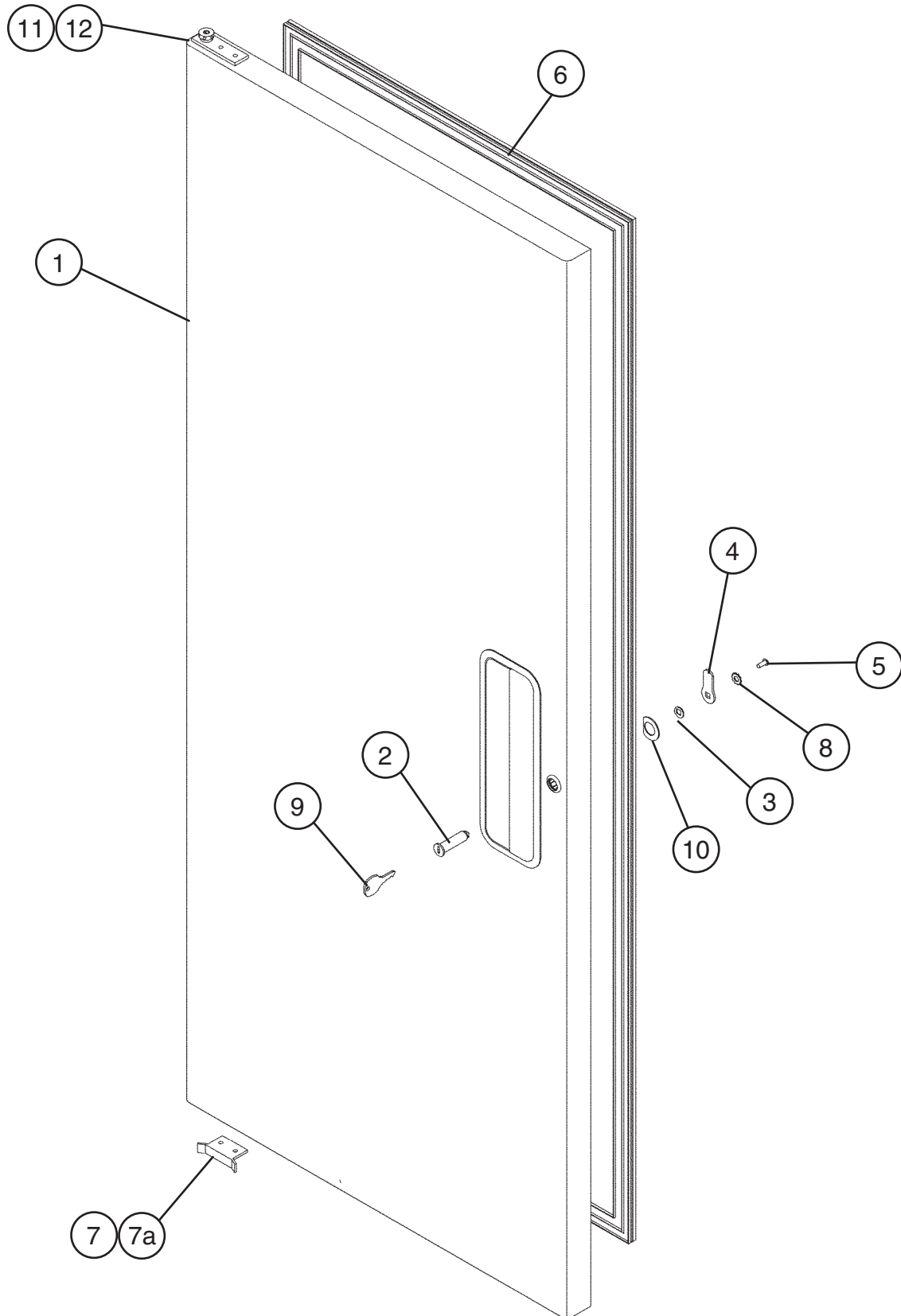

Title: **N. Door-Left** Model: **FH2-SSB**

Index No.	Description	Material or Model Number	Part Number	Required Number								
				H-0	J-0 to J-2	L-5 to M-7	N-6 to Q-5					
1	Door-Prefoam (L)	-	1A0317G02	1	1	1	-					
			1A0317G04				1					
2	Lock-Tumbler	M4-5813-001	4A0462-01	1	1	1	1					
3	Lock-Stop Washer	M5-8060-103	4A0458-01	1	1	1	1					
4	Cam-Door Lock	P.S	4A0228-01	1	1	1	1					
5	Lock-Screw	SS	4A0461-01	1	1	1	1					
6	Gasket-Door	Jarrow #P-2209 244A Gray	3A0273-01	1	1	1	1					
7	Stop-Door	SS	4A0351-01	1	1	-						
7a	Screw-Countersunk	5X20, SS	7C42-0520	2	-							
	Truss Head Screw	5X25, SS	7C32-0525		2	-						
8	Lock-Washer	SS	4A0459-01	1	1	1	1					
9	Lock-Key	M5-0680-111	4A0460-01	1	1	1	1					
10	Washer-Door Lock	SS	4A0670-01	1	1	1	1					
11	Hinge-Spring		4A3312-02	1	1	1	1					
12	Hinge-Spring Cart		4A0438-02	1	1	1	1					

## P. Mullion-Vertical FH2-SSB

H-0, J-0, J-1, J-2, L-5, M-5, M-6, N-5, N-6, P-5, P-6, Q-5

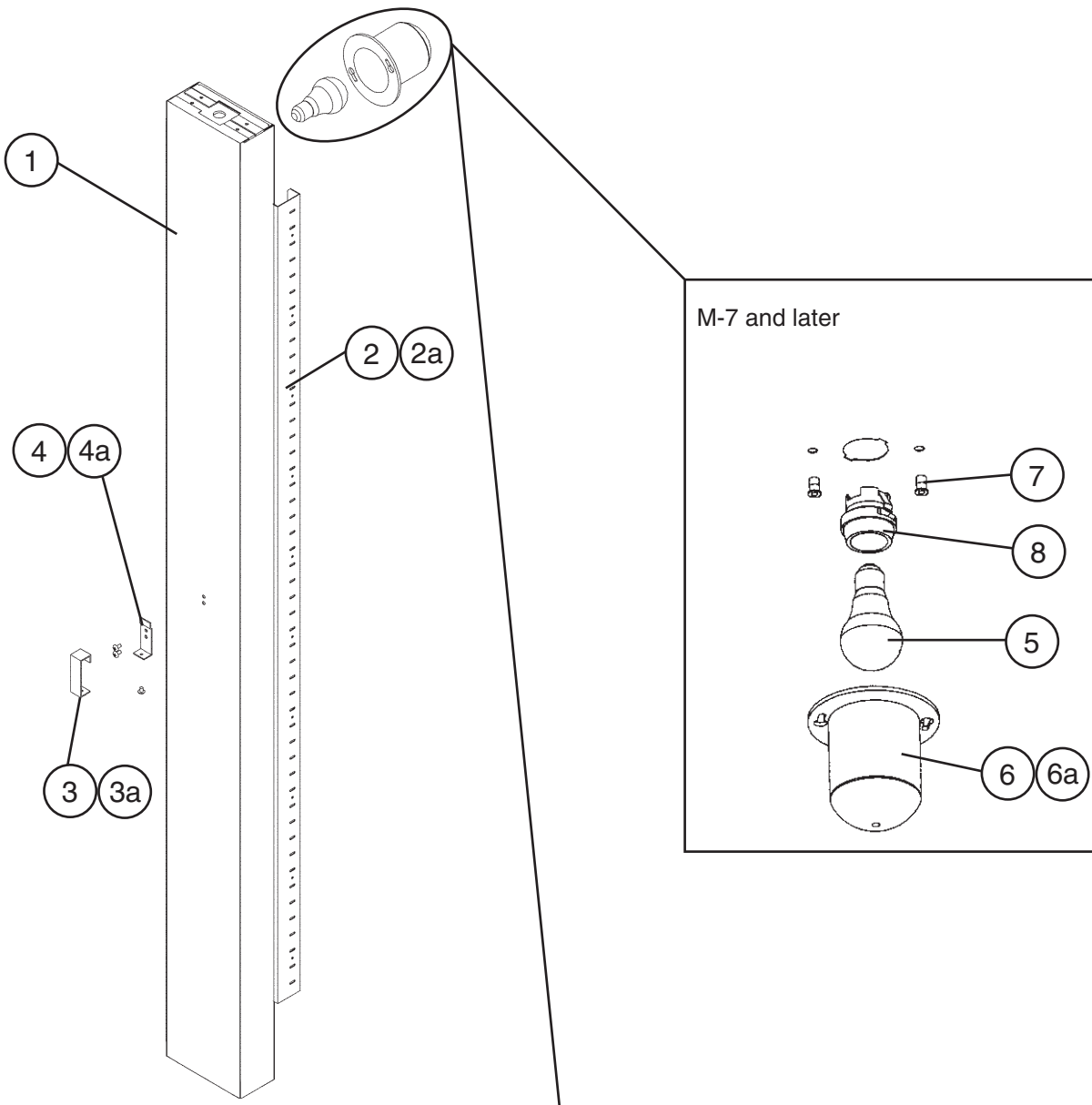

### M-6 and earlier

The santoprene light socket was changed to a porcelain lampholder at M-7. This change is non-interchangeable. If the light socket is not operating on a unit with a santoprene light socket, Hoshizaki recommends replacement with HS-3554.

#### Note:

Parts 5, 6 and 6a are not included in HS-3554; they are shown for reference only.

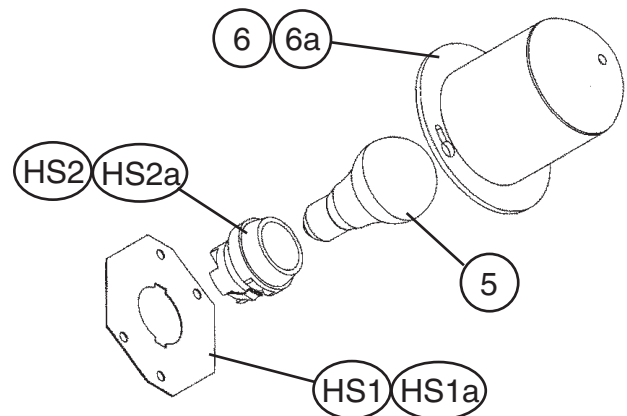

Title: <b>P. Mullion-Vertical</b> Model: <b>FH2-SSB</b>												
Index No.	Description	Material or Model Number	Part Number	Required Number								
				H-0	J-0 to L-5	M-5 M-6	M-7 N-5	N-6 to P-6	Q-5			
1	Mullion-Prefoam	-	2A1288G01	1	1	-						
			2A1288G05			1	1	1	1			
2	Pilaster-Mullion	SS	2A0205-01	2	2	2	-					
			2A0205-02				2	2	-			
			2A3246-01							2		
2a	Truss Head Screw	4x20 SS	7C32-0420	6	6	6	6	-				
		5x10, SS	7C32-0510					6	6			
3	Plate-Strike (Front)	SS	4A0355-01	1	1	1	1	1	1			
3a	Truss Head Screw	4x8, SS	7C32-0408	1	1	1	1	1	1			
4	Plate-Strike (Base)	SS	4A0354-01	1	1	1	1	1	1			
4a	T2 Screw	4x8, SS	7P32-0408	2	2	2	2	2	2			
5	Bulb-Light	GE, 40A15	4A0437-01	1	1	1	-					
		-	4A2420-01				1	1	1			
6	Shield-Light	2778-1010-3000	4A0465-01	1	1	1	1	1	1			
6a	Truss Head Screw	5x10, SS	7C32-0510	2	-							
	Cheese Head Screw	5x12, SS	7C52-0512		2	2	2	2	2			
7	Insert – Threaded Wide	-	4A0839-01	Non-interchangeable part change. If light socket is not operating for these codes, Hoshizaki recommends replacement with HS-3554 (below).			2	2	2			
8	Lampholder	-	4A2862-01				1	1	1			

HS-3554-Lampholder Conversion Kit												
Index No.	Description	Material or Model Number	Part Number	Required Number								
				M-6 and earlier								
HS1	Plate-Lampholder Mount	SS	4A2880-01	1								
HS1a	Cheese Head Screw	SS	7C52-0512	2								
HS2	Lampholder		4A2862-01	1								
HS2a	Terminal-Flag	DNFR18-250FIBK	8101-18FJ	2								

## Q. Door-Half (UR)

### FH2-SSB-HD

J-1, L-5, M-6, M-7, N-6, P-5, P-6, Q-5

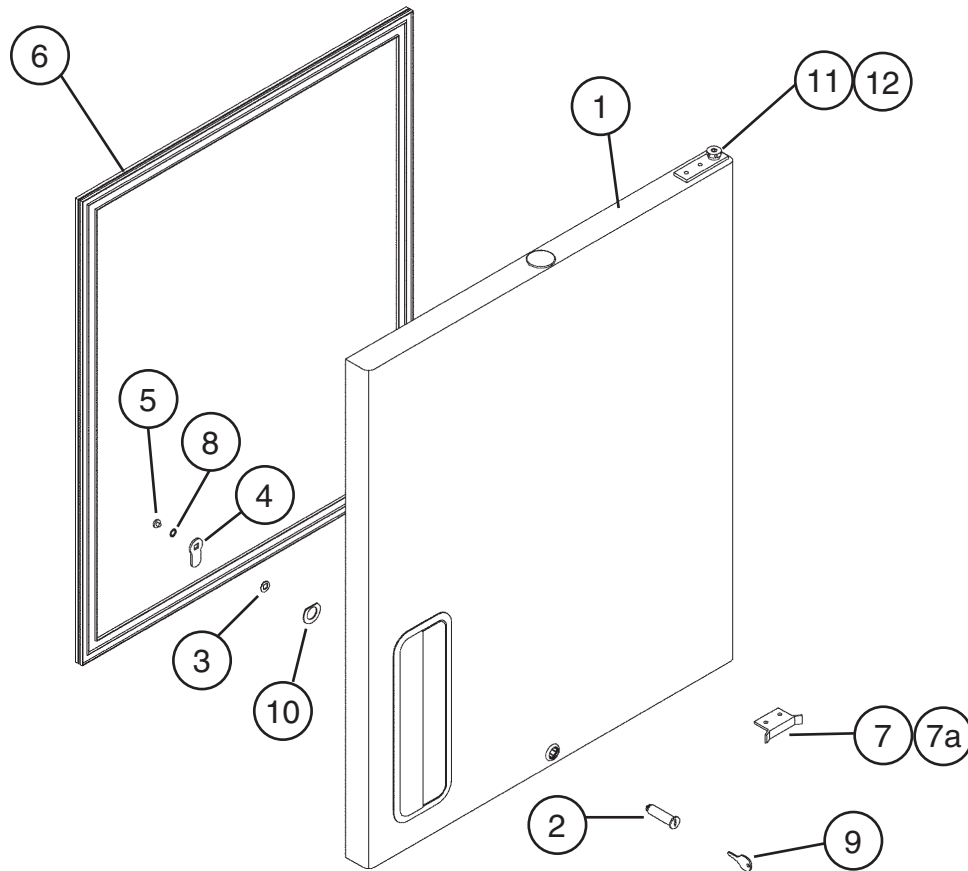

Title: Q. Door-Half (UR) Model: FH2-SSB-HD										
Index No.	Description	Material or Model Number	Part Number	Required Number						
				J-1	L-5 to M-7	N-6 to Q-5				
1	Door-Prefoam (UR)	-	1A0325G01	1	1	-				
			1A0325G03			1				
2	Lock-Tumbler	M4-5813-001	4A0462-01	1	1	1				
3	Lock-Stop Washer	M5-8060-103	4A0458-01	1	1	1				
4	Cam-Door Lock	P.S	4A0228-01	1	1	1				
5	Lock-Screw	SS	4A0461-01	1	1	1				
6	Gasket-Door(Half)	Jarrow #P-2209 244A Gray	3A0273-02	1	1	1				
7	Stop-Door	SS	4A0351-01	1	-					
7a	Truss Head Screw	5x25, SS	7C32-0525	2	-					
8	Lock-Washer	SS	4A0459-01	1	1	1				
9	Lock-Key	M5-0680-111	4A0460-01	1	1	1				
10	Washer-Door Lock	SS	4A0670-01	1	1	1				
11	Hinge-Spring		4A3312-01	1	1	1				
12	Hinge-Spring Cart		4A0438-01	1	1	1				



# R. Door-Half (LR) FH2-SSB-HD

J-1, L-5, M-6, M-7, N-6, P-5, P-6, Q-5

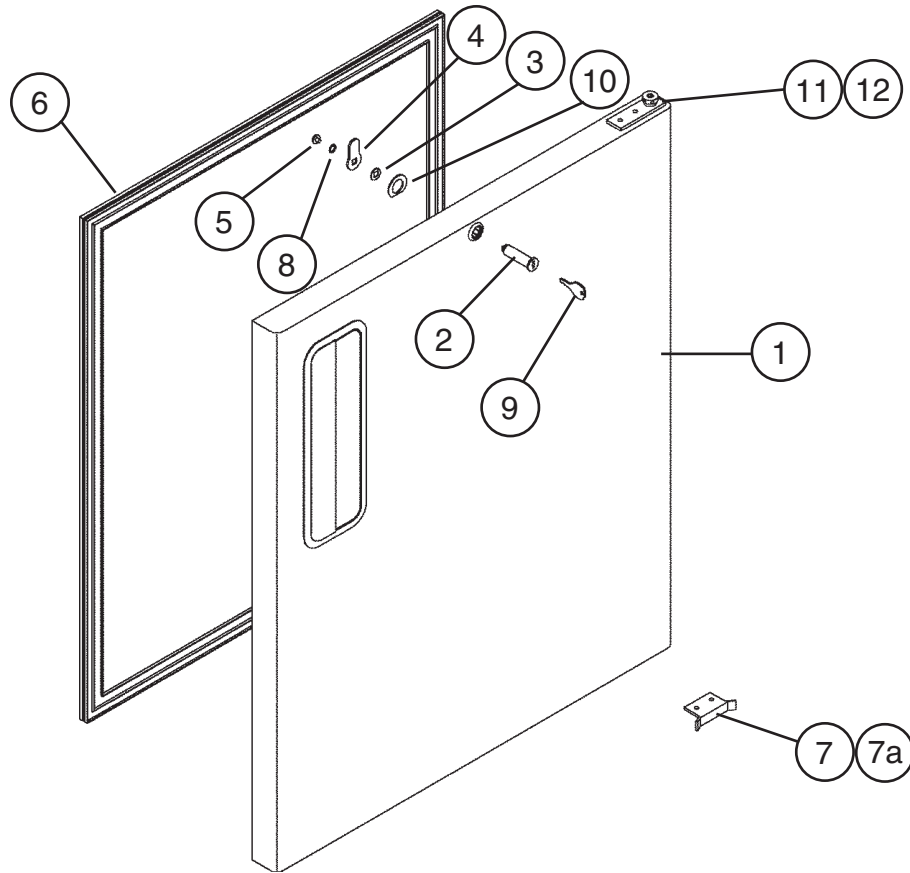

Title: R. Door-Half (LR) Model: FH2-SSB-HD										
Index No.	Description	Material or Model Number	Part Number	Required Number						
				J-1	L-5 to M-7	N-6 to Q-5				
1	Door-Prefoam (LR)	-	1A0323G01	1	1	-				
			1A0323G03			1				
2	Lock-Tumbler	M4-5813-001	4A0462-01	1	1	1				
3	Lock-Stop Washer	M5-8060-103	4A0458-01	1	1	1				
4	Cam-Door Lock	P.S	4A0228-01	1	1	1				
5	Lock-Screw	SS	4A0461-01	1	1	1				
6	Gasket-Door (Half)	Jarrow #P-2209 244A Gray	3A0273-02	1	1	1				
7	Stop-Door	SS	4A0351-01	1	-					
7a	Truss Head Screw	5x25, SS	7C32-0525	2	-					
8	Lock-Washer	SS	4A0459-01	1	1	1				
9	Lock-Key	M5-0680-111	4A0460-01	1	1	1				
10	Washer-Door Lock	SS	4A0670-01	1	1	1				
11	Hinge-Spring		4A3312-01	1	1	1				
12	Hinge-Spring Cart		4A0438-01	1	1	1				

# S. Door-Half (UL)

## FH2-SSB-HD

J-1, L-5, M-6, M-7, N-6, P-5, P-6, Q-5

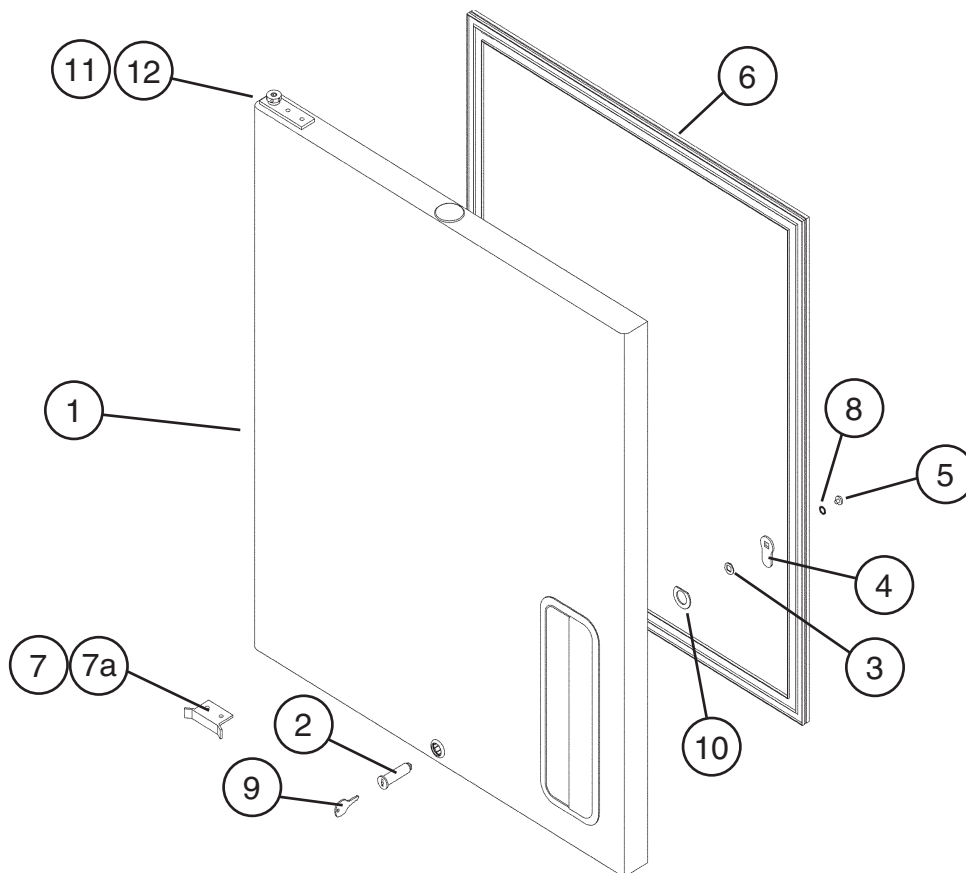

Title: S. Door-Half (UL) Model: FH2-SSB-HD										
Index No.	Description	Material or Model Number	Part Number	Required Number						
				J-1	L-5 to M-7	N-6 to Q-5				
1	Door-Prefoam (UL)	-	1A0323G02	1	1	-				
			1A0323G04			1				
2	Lock-Tumbler	M4-5813-001	4A0462-01	1	1	1				
3	Lock-Stop Washer	M5-8060-103	4A0458-01	1	1	1				
4	Cam-Door Lock	P.S	4A0228-01	1	1	1				
5	Lock-Screw	SS	4A0461-01	1	1	1				
6	Gasket-Door(Half)	Jarrow #P-2209 244A Gray	3A0273-02	1	1	1				
7	Stop-Door	SS	4A0351-01	1	-					
7a	Truss Head Screw	5x25, SS	7C32-0525	2	-					
8	Lock-Washer	SS	4A0459-01	1	1	1				
9	Lock-Key	M5-0680-111	4A0460-01	1	1	1				
10	Washer-Door Lock	SS	4A0670-01	1	1	1				
11	Hinge-Spring		4A3312-02	1	1	1				
12	Hinge-Spring Cart		4A0438-02	1	1	1				

# T. Door-Half (LL) FH2-SSB-HD

J-1, L-5, M-6, M-7, N-6, P-5, P-6, Q-5

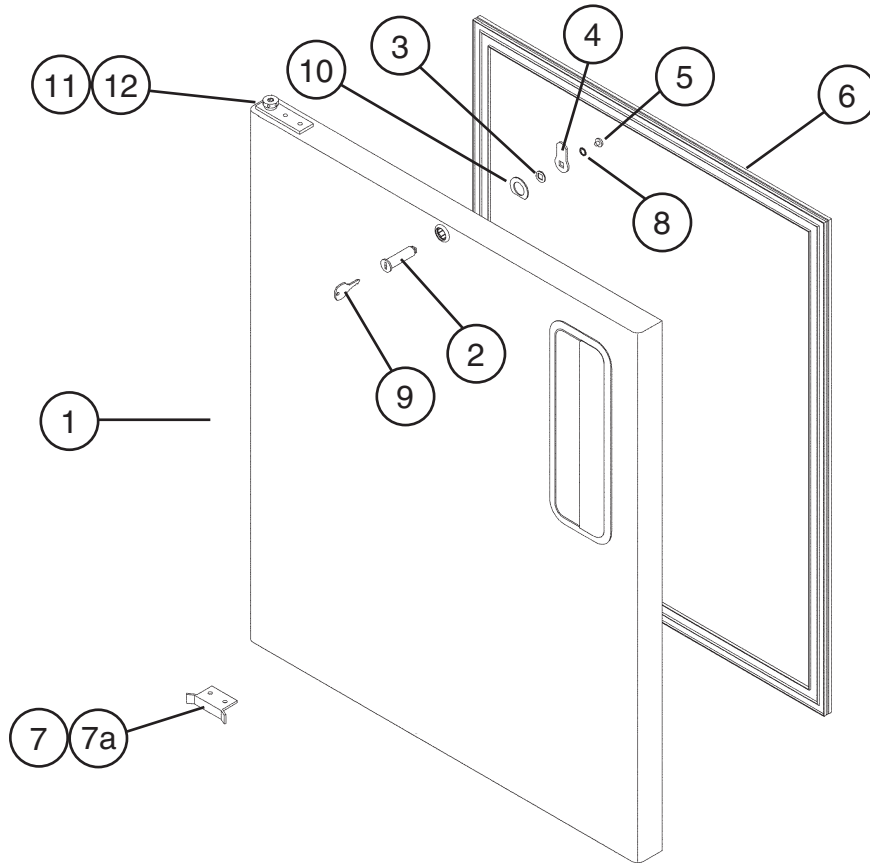

Title: T. Door-Half (LL) Model: FH2-SSB-HD													
Index No.	Description	Material or Model Number	Part Number	Required Number									
				J-1	L-5 to M-7	N-6 to Q-5							
1	Door-Prefoam (LL)	-	1A0325G02	1	1	-							
			1A0325G04			1							
2	Lock-Tumbler	M4-5813-001	4A0462-01	1	1	1							
3	Lock-Stop Washer	M5-8060-103	4A0458-01	1	1	1							
4	Cam-Door Lock	P.S	4A0228-01	1	1	1							
5	Lock-Screw	SS	4A0461-01	1	1	1							
6	Gasket-Door(Half)	Jarrow #P-2209 244A Gray	3A0273-02	1	1	1							
7	Stop-Door	SS	4A0351-01	1	-								
7a	Truss Head Screw	5x25, SS	7C32-0525	2	-								
8	Lock-Washer	SS	4A0459-01	1	1	1							
9	Lock-Key	M5-0680-111	4A0460-01	1	1	1							
10	Washer-Door Lock	SS	4A0670-01	1	1	1							
11	Hinge-Spring		4A3312-02	1	1	1							
12	Hinge-Spring Cart		4A0438-02	1	1	1							

# U. Mullion-Cross FH2-SSB-HD

J-1, L-5, M-6, M-7, N-6, P-5, P-6, Q-5

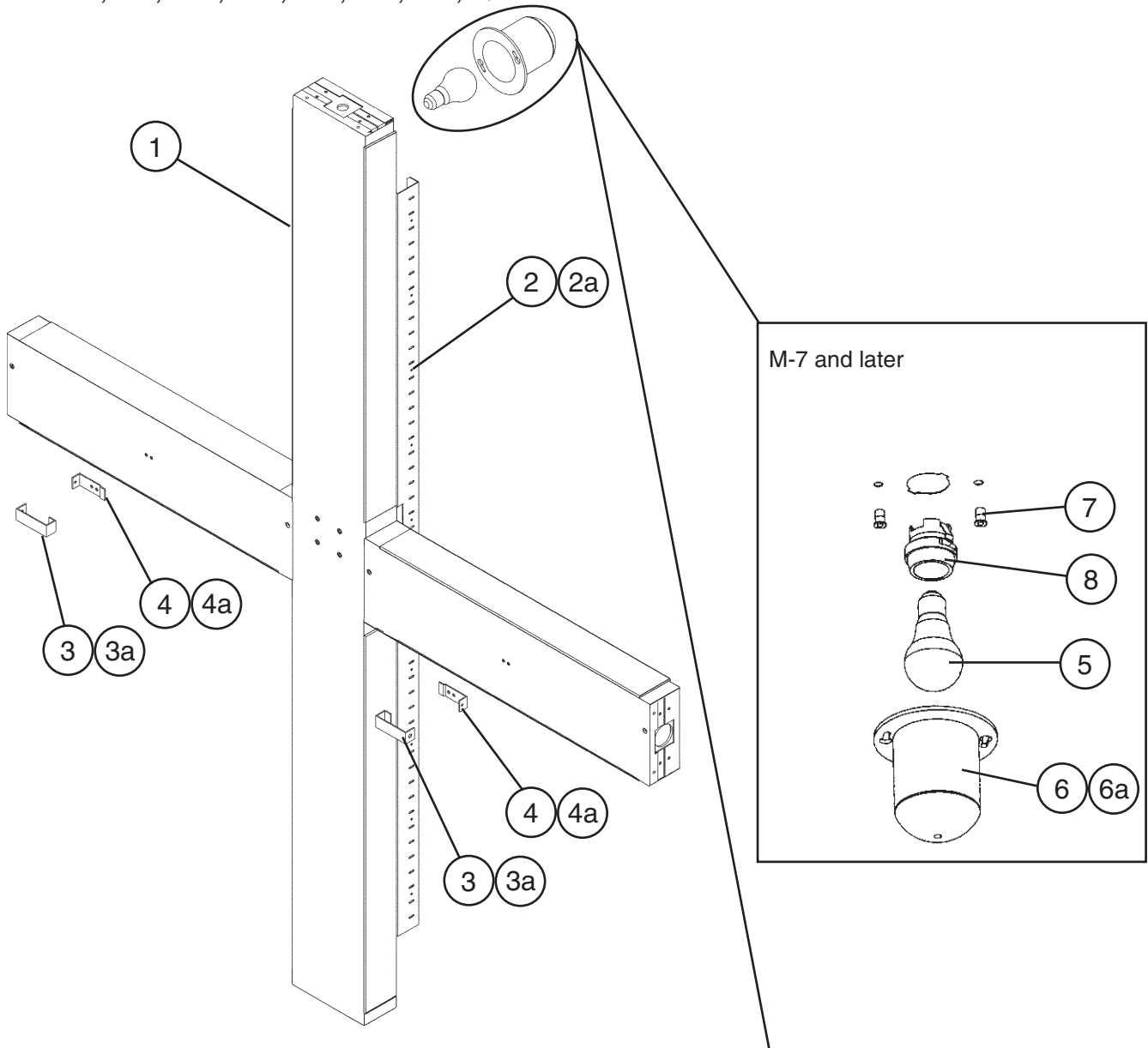

## M-6 and earlier

The santoprene light socket was changed to a porcelain lampholder at M-7. This change is non-interchangeable. If the light socket is not operating on a unit with a santoprene light socket, Hoshizaki recommends replacement with HS-3554.

### Note:

Parts 5, 6 and 6a are not included in HS-3554; they are shown for reference only.

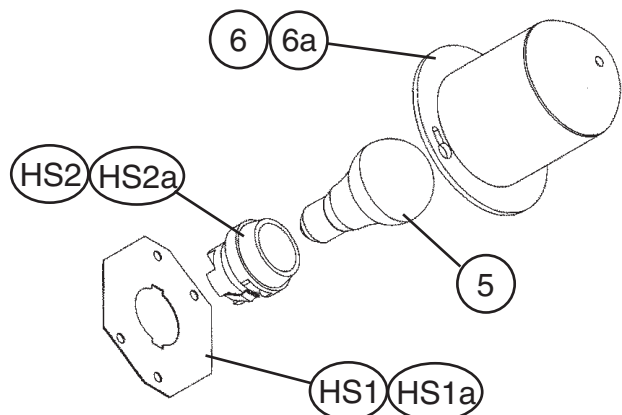

Title: <b>U. Mullion-Cross</b> Model: <b>FH2-SSB-HD</b>												
Index No.	Description	Material or Model Number	Part Number	Required Number								
				J-1	L-5	M-6	M-7 to P-6	Q-5				
1	Mullion-Prefoam	-	2A1351G01	1	-							
			2A1351G04		1	1	1	1				
2	Pilaster-Mullion	SS	2A0205-02	2	2	2	2	-				
			2A3246-01					2				
2a	Truss Head Screw	4x20, SS	7C32-0420	6	6	6	6	6				
3	Plate-Strike(Front)	SS	4A0355-01	2	2	2	2	2				
3a	Truss Head Screw	4x8, SS	7C32-0408	2	2	2	2	2				
4	Plate-Strike (Base)	SS	4A0354-01	2	2	2	2	2				
4a	T2 Screw	4x8, SS	7P32-0408	4	4	4	4	4				
5	Bulb-Light	GE, 40A15	4A0437-01	1	1	-						
			4A2420-01			1	1	1				
6	Shield-Light	2778-1010-3000	4A0465-01	1	1	1	1	1				
6a	Truss Head Screw	5x10, SS	7C32-0510	2	-							
	Cheese Head Screw	5x12, SS	7C52-0512		2	2	2	2				
7	Insert – Threaded Wide	-	4A0839-01	Non-interchangeable part change. If light socket is not operating for these codes, Hoshizaki recommends replacement with HS-3554 (below).			2	2				
8	Lampholder	-	4A2862-01				1	1				

HS-3554-Lampholder Conversion Kit												
Index No.	Description	Material or Model Number	Part Number	Required Number								
				M-6 and earlier								
HS1	Plate-Lampholder Mount	SS	4A2880-01	1								
HS1a	Cheese Head Screw	SS	7C52-0512	2								
HS2	Lampholder		4A2862-01	1								
HS2a	Terminal-Flag	DNFR18-250FIBK	8101-18FJ	2								

## V. Literature & Packaging

### FH2-SSB(-HD)

H-0, J-0, J-1, J-2, L-5, M-5, M-6, M-7, N-5, N-6, P-5, P-6, Q-5

Title: V. Literature & Packaging Model: FH2-SSB(-HD)												
Index No.	Description	Material or Model Number	Part Number	Required Number								
				H-0 to Q-5								
1	Instruction Manual	Paper	91A34010L	1								
Packaging (Available Only For Models Currently In Production)		<b>FH2-SSB</b>	1A0766A11	1								
		<b>FH2-SSB-HD</b>	1A0766A12	1								
1	Filler – Door		4A2977-01	2								
2	Pad – Corner		3A2598-01	4								
3	Post – Corner		3A2603-01	4								
4	Support – Corner		3A2596-01	4								
5	Stop – Door		4A1873-01	2								
6	Flat Washer		7W21I5800	4								
7	Hex Head Bolt		7B01 I5825	4								
8	Pallet		3A1815-01	1								
9	Stop – Door (Center) <b>FH2-SSB-HD Only</b>		4A1874-01	2								
10	Protector – Front		3A2595-01	1								

## Free Manuals Download Website

<http://myh66.com>

<http://usermanuals.us>

<http://www.somanuals.com>

<http://www.4manuals.cc>

<http://www.manual-lib.com>

<http://www.404manual.com>

<http://www.luxmanual.com>

<http://aubethermostatmanual.com>

Golf course search by state

<http://golfingnear.com>

Email search by domain

<http://emailbydomain.com>

Auto manuals search

<http://auto.somanuals.com>

TV manuals search

<http://tv.somanuals.com>