

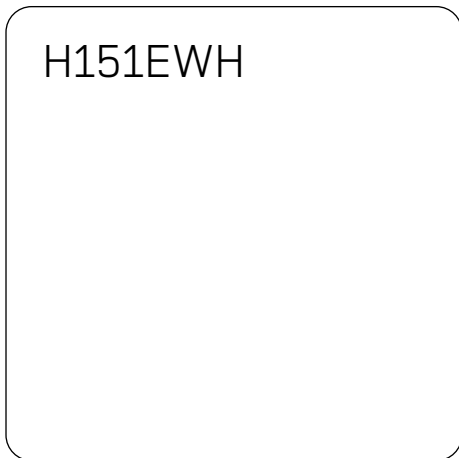

Designed for the real world

Instructions

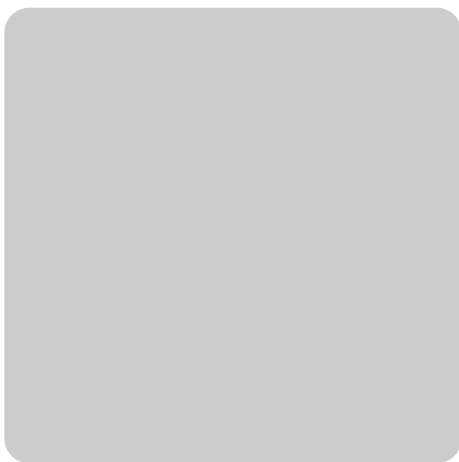

Contents

Introduction	2
Installation	3
For your Safety – Always	4
For your Safety – Never	5
Features	6
Control Panel	7
Hotplates General Information Notes	8-9
Temperature Conversion Chart	10
Grill	11
Grill Chart	12
Oven	13
Oven Cookery Notes	13-17
Care and Cleaning	18-19
Something Wrong with your Cooker	20
Key Contacts	Back Cover

You must read these instructions prior to using the appliance and retain them for future reference.

Introduction

Your new appliance is guaranteed* and will give lasting service. This guarantee is only applicable if the appliance has been installed in accordance with the installation instructions detailed in this booklet.

To help make best use of your cooking equipment, please read this booklet carefully.

The cooker is designed specifically for domestic use and responsibility will not be accepted for use in any other installation.

**When the cooker is first used an odour may be emitted,
this will cease after a period of use**

When first using the cooker ensure that the room is well ventilated (e.g. open a window or use an extractor fan) and that persons who may be sensitive to the odour avoid any fumes. It is suggested that any pets be removed from the room until the smell has ceased. This odour is due to temporary finish on oven liners and elements and also any moisture absorbed by the insulation.

*** The guarantee is subject to the provisions that the appliance:**

- (a) Has been used solely in accordance with the Users Instruction Book.**
- (b) Has been properly connected to a suitable supply voltage as stated on the rating plate attached to this equipment.**
- (c) Has not been subjected to misuse or accident or been modified or repaired by any person other than the authorised employee or agent.**
- (d) Has been correctly installed.**

DISPOSAL OF YOUR PRODUCT

To minimise the risk of injury to children please dispose of your product carefully and safely. Remove all doors and lids. Remove the mains cable (where fitted) by cutting off flush with the appliance and always ensure that no plug is left in a condition where it could be connected to the electricity supply.

To help the environment, Local Authority instructions should be followed for the disposal of you product.

This appliance conforms to the following EEC Directives:

Electromagnetic Compatibility	Low Voltage Equipment
89/336/EEC	73/23/EEC
92/31/EEC	93/68/EEC
93/68/EEC	



Installation

WARNING – THIS APPLIANCE MUST BE EARTHED.

Mains Connection

Your cooker should have been checked to ensure that the voltage corresponds with your supply voltage, this is stated on the **rating plate**, which is situated on the rear panel.

The cooker must be connected by a competent person such as one who is NICEIC registered contractor to suitable double-pole control unit with a minimum rating of 45A and a minimum contact

clearance of 3mm, which should be fitted adjacent to the cooker, in accordance with IEE regulations. The control unit must be within 2 metres of but not directly above the appliance and should be easily accessible in the event of an emergency.

The power supply cable should conform to B.S.6004 with a conductor size of 6mm², minimum.

Access to the **mains terminals** is gained by removing the **rear access cover**. The mains cable must pass through the cable clamp adjacent to the terminal block. Sufficient cable should be used to allow the cooker to be pulled out for servicing.

Ensure that the mains cable is routed away from any brackets affixed to the rear panel and is not trapped to the rear wall when pushing the cooker into position between cabinets.

Note: If the cooker is to be placed on a base, precautions must be taken to prevent it from slipping off the base.

Siting the Cooker

The cooker is designed to fit between kitchen cabinets spaced 500mm apart. The space either side need only be sufficient to allow withdrawal of the cooker for servicing. It can be used with cabinets one side or both as well as in an angled corner setting. It can also be used freestanding.

This cooker is a Type X appliance, as such adjacent side walls which project above hob level, must not be nearer to the cooker than 150mm and should be protected by heat resistant material. Any overhanging surface or cooker hood should not be nearer 650mm.

The height of the cooker can be adjusted by means of adjustable feet in the plinth (900mm - 915mm). Adjust the feet by tilting the cooker from the side. Then install the cooker into position.

Moving the Cooker

Before moving your cooker, switch off at the cooker control unit, ensure that it is cool. Open the grill door sufficiently to allow a comfortable grip on the underside front edge of the oven roof, avoiding any grill elements.

Radio Interference

This appliance conforms to EN 55014 regarding suppression of radio and television interference.

Note: Take care in moving the cooker as it is heavy. Take care to ensure that any floor covering is not damaged.

Safety Information

**When used properly your appliance is completely safe but as with any electrical product there are certain precautions that must be observed.
PLEASE READ THE PRECAUTIONS BELOW BEFORE USING YOUR APPLIANCE.**

Always

- Remove all packing from the appliance before switching on for the first time.
- Understand the controls prior to using the appliance.
- Keep children away from the appliance when cooking as the surfaces will get extremely hot during and after use.
- Turn controls **off** when not in use.
- Stand back when opening an oven door to allow any build up of steam or heat to disperse.
- Always use dry good quality oven gloves when removing items from the oven/grill.
- Always place pans centrally over the hotplate making sure handles are kept away from the edge of the hob and cannot become heated by other hotplates or pans.
- Always take care to avoid heat or steam burns when operating the controls.
- Always turn off the electricity supply at the wall switch and allow the appliance to cool before cleaning (or changing an oven lamp if fitted).
- Always make sure the shelves are in the correct position before switching on the oven or grill.
- Always keep the oven/grill door closed when the appliance is not in use.
- Always keep the appliance clean as a build up of grease or fat from cooking can cause a fire.
- Always follow the basic principles of food handling and hygiene to prevent the possibility of bacterial growth.
- Always keep ventilation slots clear of obstructions.
- Always refer servicing to a qualified appliance service engineer.
- Always take care when removing items from the grill compartment when the lower oven is in use as the contents will be hot
- Always turn off the electricity supply to the appliance at the wall switch should any glass panel (if fitted) crack or shatter and then DO NOT USE THE APPLIANCE until repaired.
- During use, the oven becomes hot. Care should be taken to avoid touching heating elements inside the oven.

Safety Information

Never

- Never stare at Halogen heating units
- Never leave children unsupervised where a cooking appliance is installed as all surfaces will be hot during and after its use.
- Never allow anyone to sit or stand on any part of the appliance.
- Never store items above the appliance that children may attempt to reach.
- Never leave anything on the hob surface when unattended and not in use.
- Never remove the oven shelves whilst the oven is hot.
- Never heat up unopened food containers as pressure can build up causing the container to burst.
- Never store chemicals/food stuffs or pressurised containers in or on the appliance, or in cabinets immediately above or next to the appliance.
- Never place flammable or plastic items on or near the hob.
- Never fill a deep fat frying pan more than 1/3 full of oil, or use a lid.
DO NOT LEAVE DEEP FAT FRYING PANS UNATTENDED WHILE COOKING.
- Never use the appliance as a room heater.
- Never use the grill to warm plates.
- Never dry any items on either the hob or oven doors.
- Never install the appliance next to curtains or other soft furnishings.
- Never operate the grill with the grill door closed as this will cause the appliance to over heat.
- Never use steam cleaners.

SAFETY ADVICE IN CASE OF A CHIP-PAN FIRE

In the event of a chip pan fire or any other pan fire.

1. TURN OFF THE COOKER APPLIANCE AT THE WALL SWITCH.
2. COVER THE PAN WITH A FIRE BLANKET OR DAMP CLOTH, this will smother the flames and extinguish the fire.
3. LEAVE THE PAN TO COOL FOR AT LEAST 60 MINUTES BEFORE MOVING IT. Injuries are often caused by picking up a hot pan and rushing outside with it.

NEVER USE A FIRE EXTINGUISHER TO PUT OUT A PAN FIRE as the force of the extinguisher is likely to tip the pan over.
Never use water to extinguish oil or fat fires.

Features

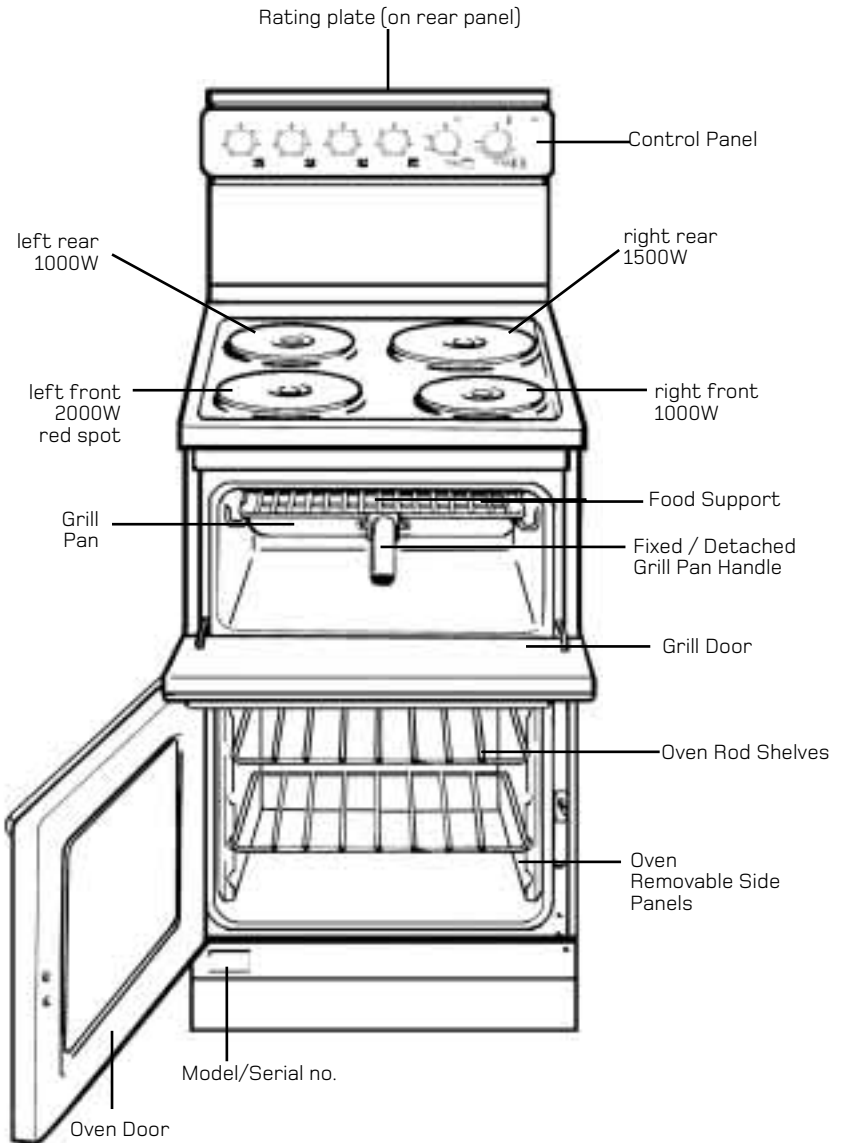

Control Panel

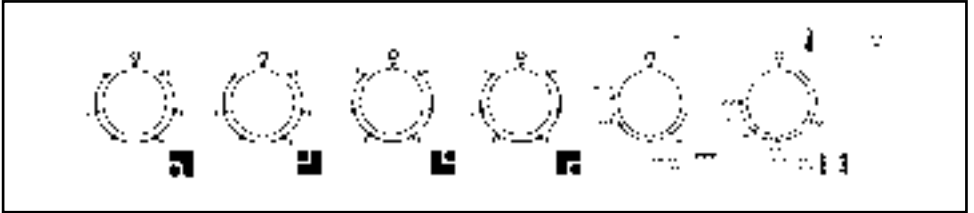

Note: Always ensure that all controls are in the OFF position, when appliance is not in use.

Hotplates General Information Notes

Note: Under no circumstances should the hob be used with aluminium foil in contact with the hob surface.

Use of Hotplates

The controls set the hotplates at six pre-set power levels. Each control can be used to select one of six temperature settings from a minimum at position 1 to a maximum at position 6. The red spot hotplate heats up more rapidly to give faster boiling.

Control Settings Guide

This table is provided only as a guide – settings also depend on the type of pan used and the quality of food.

Knob Position	Type of food
1	To melt butter, chocolate etc.
1 or 2	To heat food gently. To keep small amounts of water simmering. To heat sauces containing egg yolks and butter. To simmer: stews, meat, fish, vegetables, fruit.
3	To heat solid or liquid foods. Keep water boiling. Thaw frozen vegetables. Make 2-3 egg omelettes.
4 or 5	To cook foods, just above simmering. To maintain 'rolling' boil for preserve making.
5 or 6	To seal meat and fry fish.
6	Frying potatoes. Bringing water to the boil. Deep fat frying. Dissolve sugar for preserve making.

Safety requirements for deep fat frying

1. Use a deep pan, large enough to completely cover the appropriate heating area.
2. Never fill the pan more than one-third full of oil.
3. Never leave oil or fat unattended during the heating or cooking period.
4. Never try to fry too much food at a time, especially frozen food. This only lowers the temperature of the oil or fat too much, resulting in greasy food.
5. Always dry food thoroughly before frying, and lower it slowly into the hot oil or fat. Frozen foods, in particular, will cause frothing and spitting, if added too quickly.
6. Never heat fat, or fry, with a lid on the pan.
7. Keep the outside of the pan clean and free from streaks of oil or fat.

Hob General Information

CHOICE OF UTENSILS

Every Electric Hob deserves the right choice of utensils.

We recommend for optimum performance the use of good quality utensils.

PANS SHOULD NOT



Be concave
(bowed in)



Be convex
(bowed out)



Be rimmed



Be deeply ridged



But essentially Flat

Always ✓	Never ✗
<ul style="list-style-type: none"> ● Use good quality flat-based cookware on all electric heat sources. ● Ensure pans have clean, dry bases before use. ● Ensure pans match size of heating area. ● Remember good quality pans retain heat well, so generally only a low or medium heat is necessary. ● Ensure pan handles are positioned safely and away from heat sources. ● Lift pans, do not drag. ● Use pan lids except when frying. ● Deal with spillage immediately but with care. 	<ul style="list-style-type: none"> ● Use gauze, metal pan diffusers, asbestos mats and stands e.g. Wok stands – they can cause overheating. ● Use utensils with skirts or rims e.g. buckets and some kettles. ● Use badly dented or distorted pans. ● Leave an element switched on when not cooking. ● Cook food directly on the hotplate. ● Drag or slide utensils across the hob surface. ● Place large preserving pans or fish kettles across two hotplates. ● Place plastic vessels or utensils on a hot hob. ● Use the hob as an area for storage



Always place pans centrally on the hotplate



Temperature Conversion Chart

Gas Mark	°F	Main Convection Oven	Top Convection Oven	Main Fan Oven
1/2	250	120	110	100
1	275	140	130	120
2	300	150	140	130
3	325	160	150	140
4	350	180	170	160
5	375	190	180	170
6	400	200	190	180
7	425	220	210	200
8	450	–	220	210
9	475	–	–	220

Grill

Setting the Grill

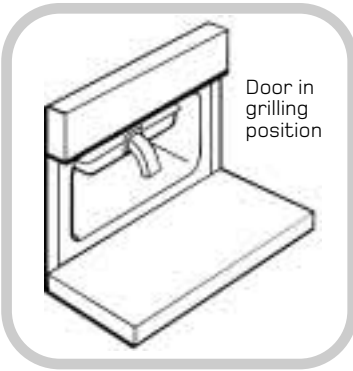

CAUTION – ACCESSIBLE PARTS WILL BECOME HOT WHEN THE GRILL IS IN USE. CHILDREN SHOULD BE KEPT AWAY.

THE GRILL WILL NOT OPERATE WITH THE GRILL DOOR CLOSED

Never: line the grill pan with aluminium foil.

The grill control is designed to provide variable heat control of the grill element. Open the grill door, preheat the grill at High setting for approximately 5 minutes. When toasting, place the grill pan on the grill runner. Position the pan centrally below the grill element. Leave the control at High setting for toast, sealing and fast cooking of foods. For thicker foods requiring longer cooking, turn the control to a lower setting after the initial sealing of both sides at High setting. The thicker the food the lower the control should be set.

See chart on guide to grilling.

Remember to switch off the grill control at the end of cooking.

Grill Compartment as a hotcupboard. Plates and dishes placed on the floor of the compartment will be heated from the oven when in use. **Do not operate the grill control when using the compartment as a hotcupboard.**

Grill pan handle

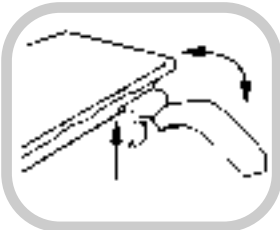

The grill pan handle is detachable from the pan, to facilitate cleaning and storage. The handle can be either detachable from or fixed to the pan. For a fixed handle remove the screw and washers from the grill pan bracket, tilt the handle over the recess adjacent to the bracket.



Slide the handle towards the centre of the pan and let the handle locate over the bracket.



Replace screw and washers and ensure that they are fully tightened up. For a detachable handle remove screw and washers from grill pan and discard.

Warning: Ensure when using grill pan handle in the detachable manner it is centralised and secure.

Guide To Grilling

Pre - heat the grill for 5 minutes on maximum control setting before grilling

GRILL CHART

Food	Grill Setting	Approximate Cooking time
Toasting of Bread products	High	3 - 10 mins.
Small cuts of meat, sausages, bacon, etc.	Med - High	15 - 20 mins.
Chops etc. Gammon steaks Chicken pieces	Med	20 - 25 mins. Wire food support used in upturned position for chicken.
Fish: fingers Whole Fillets	Med	10 - 20 mins. Whole fish and fillets placed in the base of the grill pan.
Fish in breadcrumbs	Med	15 - 20 mins.
Pre - Cooked potato products	Med	15 - 20 mins.
Pizzas	Med	12 - 15 mins. in the base of the grill pan.
Browning of food	High	8 - 10 mins. Dish placed directly on base of the grill pan and pan placed on the base of the grill compartment.

The settings in the above guide have been developed to cook food successfully without excessive fat spitting and splashing.

Oven

Oven Control

With the oven door closed, heating of the oven is achieved by turning the control clockwise to the required 'oven temperature' scale on the control panel, as recommended in the temperature charts. The pilot light will immediately come on and go off during cooking as the thermostat maintains the correct temperature.

Note: At the end of the cooking period there may be a momentary puff of steam when the oven door is opened. This will disperse in a few seconds and is perfectly normal characteristics of an oven with a good door seal.

Note: Remember to switch off the oven control after cooking is finished.

Oven Cookery Notes

To prepare meat for roasting in your electric oven

The 'oven temperature charts' are a guide only, giving approximate cooking temperatures and times.

To suit personal taste and requirements, it may be necessary to increase or decrease temperatures by 10°C.

Wipe the joint, dry well with a clean cloth, kitchen tissue, etc., and weigh it. Meat which has been stored in a refrigerator, should be allowed to come to room temperature for approximately 30 minutes before cooking.

Always completely thaw frozen meat before cooking. Beef, lamb and mutton may be lightly floured, but pork should have the rind scored, brushed over lightly with olive oil, and sprinkled with salt – for crisp crackling.

Place the joint in a suitably sized meat pan (a small joint in a large meat pan causes unnecessary oven splashing). Small joints weighing less than 1.5kg (3lbs) may be pot roasted. Additional fat should not be used, except for veal, very lean meat, poultry, which can either be 'larded' with fat bacon, or brushed over **very sparingly** with melted fat/cooking oil. When potatoes are roasted round the joint, they only require to be coated in melted fat/cooking oil. It is not necessary to baste, when roasting in an electric oven, and liquid/stock should not be added to the meat pan.

Oven Cookery Notes

Temperature and Time

The secret of succulent, tender meat, is not to roast quickly at too high a temperature. Best results are obtained when roasting is carried out at low temperatures. When a lower temperature is used, joint loses less weight, is more tender (too high a temperature causes meat to be tough and dry), and the splashing of fat onto oven interior is reduced. When a complete meal is being cooked in the oven, cooking time may need to be increased, and temperature may need to be raised for approximately the last 30 minutes of the cooking period (for instance when cooking Yorkshire pudding to serve with roast beef).

The times and temperature suggested should be used as a guide but may vary according to:-

1. Whether you prefer meat rare, medium or well done.
2. The size and shape of your joint.
 - a) A short thick joint requires a longer cooking period than a long thin joint.
 - b) A small joint under 1.5kg (3lbs) takes longer per 450g (1lb) than a large one, whereas a large joint over 3kg (6lbs) will cook in the time given for 'minutes' per 450g (1lb) without the 'minutes' over added.
 - c) Boned/rolled and stuffed joints take longer to cook through than those with a bone. (The weight of stuffing should be added to the oven ready weight of meat/poultry to calculate roasting times.)

Meat pan and rod shelves

Never use meat pans larger than 390 x 300mm (15"x12") and baking trays no larger than 330x255mm (13"x10"), these should be positioned centrally on the oven shelf. Food should not be placed directly on the floor of the oven. To avoid unnecessary cleaning, rod shelves which are not in use, should be removed from the oven.

Oven Temperature Chart – Meat

Food	Temperature and Time	Position in Oven
Beef	190/200°C approx. 25-30 mins. per 450g (1 lb) + 25 mins over	Runner 2 from bottom of oven
Lamb/Mutton	190/200°C approx. 25-30 mins. per 450g (1 lb) + 25 mins over	
Pork	190/200°C approx. 30-35 mins. per 450g (1 lb) + 30 mins over	
Veal	190/200°C approx. 25-35 mins. per 450g (1 lb) + 30 mins over	
Poultry/Game	190/200°C approx. 20-25 mins. per 450g (1 lb) + 20 mins over	
Turkey	up to 5.5kg (12lb) allow 22 mins per 450g (1 lb) at 190°C e.g. 5kg (11lb) = 242 mins over 5.5kg (12lb) allow 16 mins. per 450g (1lb) at 180°C e.g. 10kg (22lb) = 352 mins	
Casserole Cooking	140/160°C according to quantity	Shelf 3
If using aluminium foil, never: <ol style="list-style-type: none"> 1. Allow foil to touch sides of oven. 2. Cover oven interior with foil. 3. Cover oven shelves with foil. 		

Oven Temperature Chart – Baking

Food	Temperature and Time	Position in Oven
Scones Small Cakes	220/230°C 10-15 mins 190/200°C approx. 20-25 mins	Runners 1 and 4 from bottom of oven
Victoria Sandwich	170/190°C 6½"-7" tins approx. 20 mins 8"-8½" tins approx. 30 mins	Runners 1 and 4 from bottom of oven
Sponge Sandwich (fatless)	180/200°C 7" tins 15-20 mins	Runners 1 and 4 from bottom of oven
Swiss Roll	190/210°C 10-15 mins	Runner 4 from bottom of oven
Semi-rich Cakes (large)	160/180°C 6½"-7" tins 1¼-1½ hrs 8"-9" tins 2-2½ hrs	Runner 2 from bottom of oven
Christmas Cake	140/150°C according to size and richness of mixture	Runner 3 from bottom of oven
Shortcrust Pastry (Plate Tarts) Puff Pastry	190/210°C 45-50 mins approx. 220°C	Runners 1 and 4 from bottom of oven
Yorkshire Pudding Individual Yorkshire Puddings	210/220°C 40-45 mins 210/220°C approx. 20 mins	Runner 5 from bottom of oven
Milk Puddings Baked Egg Custard	140/160°C 2-2½ hrs 140/160°C 40-50 mins	Runner 3 from bottom of oven
Bread (full oven) Bread (single loaf)	230°C 50-60 mins Reducing to 230°C 45-50 mins 210/220°C after first 10 mins	Runners 1 and 4 from bottom of oven
Meringues	100/110°C Large 3½-4½ hrs Small 2½-3 hrs	Runner 1 from bottom of oven

Note: When using two shelf positions at the same time (e.g. to bake two plate tarts, full oven of bread etc.) tins should be interchanged half way through the cooking period. When baking two trays of scones, small cakes, at the same time, the lower tray may require to be baked for a few minutes longer than the top tray.

If soft tub margarine is used for cake making, temperatures recommended by the manufacturers should be followed. Temperatures recommended in this chart refer to cakes made with block margarine or butter only.

Cooking Results Not Satisfactory

Problem	Check
Grilling Uneven cooking front to back	Ensure that the grill pan is correctly positioned beneath the grill element.
Fat splattering	Ensure that the grill is not set to too high a setting.
Baking Uneven rising of cakes	Ensure that the oven shelves are level by using a spirit level on the rod shelf and adjusting, using suitable packing, e.g. wood, under the feet of the appliance. This should be checked both left to right and front to back.
Sinking of cakes	The following may cause cakes to sink: 1. Cooking at too high a temperature. 2. Using normal creaming method with soft margarine.
Over/Undercooking Fast/Slow cooking	Refer to the cooking times and temperatures given in the oven temperature charts, however, it may be necessary to increase or decrease temperatures by 10°C to suit personal taste. Do not use utensils greater than 56mm (2 ¹ / ₄ ") in height, for roasting.

Care and Cleaning

Turn OFF the main control unit and allow the cooker to cool before cleaning.

Before switching on again, ensure that all controls are in the **OFF** position.

Refer to the instructions below for cleaning the 'Stay clean' removable side oven panels.

'STAY CLEAN' OVEN LINERS

How 'Stay clean' Works

The surfaces of the 'Stay clean' oven liners are treated on the mottled face with a special vitreous enamel which absorbs cooking soils. At temperatures of 220°C (425°F) or above, the special surface enables these soils to be slowly destroyed. The higher the temperature, the more effective it is. In most cases normal cooking operations at this temperature will permit this cleaning operation to proceed during cooking. However, if higher cooking temperatures are not used regularly, it may be necessary, in order to prevent heavy soiling, to run the oven without a meat pan, at a higher temperature setting of 230°C (450°F) for a couple of hours. This may be necessary once a month or every two or three months depending on the type and amount of oven cooking.

Oven sides – It should not normally be necessary to clean the 'Stay clean' panels in water. If the user feels it is desirable to do so, remove the rod shelves and side panels and wash them in warm, soapy water, followed by rinsing in clear water. **Do not use enzyme/biological washing powder, harsh abrasives or oven chemical cleaners of any kind.**

Grill – Remove the grill pan and grid. It is best to wash these items immediately after use to prevent stains from being burnt on when used again.

Hob

Wipe the hob with a damp cloth wrung out in warm soapy water

Control Panel

Wipe over the control panel with a damp cloth and polish with a dry cloth. **Do not use** oven cleaners or aerosols, scouring pads or abrasive powder for cleaning the plastic knobs or plastic end caps as damage will occur.

Oven – Interior

Refer to the instructions above for cleaning the 'Stay clean' panels.

Remove the rod shelves for washing at the sink. Use a fine steel wool soap pad for removing stubborn stains from the rod shelves and floor of the oven. Take care during cleaning not to damage, bend or dislodge from the supporting clips the thermostat phial which is across the back of the oven just below the roof.

Care and Cleaning

Oven Door

Wipe over the door outer panel with a cloth wrung out in warm soapy water, then after wiping with a cloth wrung out in clear water, dry with a soft clean cloth.

Do not use scouring pads or abrasive powder which may scratch the surface.

Take care during cleaning not to damage or distort the door seal. Do not lift the door seal from the oven front frame, if necessary remove the seal by carefully unhooking the corner clips. Be sure to replace the oven door seal before using the appliance.

Something Wrong with your Cooker?

Before calling a Service Engineer, please check through the following lists.
THERE MAY BE NOTHING WRONG.

Problem	Check
Slight odour or small amount of smoke when using the cooker for the first time.	This is normal and should cease after a short period.
Cooker does not work at all.	Check that the switch on the control unit is in the on position.
Oven temperature seems too high or too low.	Check that the temperature has been set in accordance with the temperature charts. It may be necessary to increase or decrease the recommended temperature by up to 10°C to suit your taste.
Oven does not cook evenly.	Check that the temperature and shelf position are as recommended in the temperature charts. Check that the containers being used in the oven allow sufficient air flow around them. Check that the cooker is level.
Hotplates are slow to boil or will not simmer.	Check that your pans conform to the recommendations in these instructions.
Grilling is uneven.	Check that the grill pan has been correctly positioned.
Grill not working.	Grill will not work unless the Grill door is in the grill position (see Grilling section of this book).
Condensation on the wall at the rear of the cooker.	Steam and/or condensation may appear from the vent at the rear of the appliance when using an oven particularly for foods with a high water content e.g. frozen chips, roast chicken etc. This is normal and any excess should be wiped off.
Steam / Condensation in the oven after use.	Steam is a by-product of cooking any food with a high water content. To help minimise always: a) Try to avoid leaving food in the oven to cool after being cooked. b) Use a covered container, wherever possible

If you have been through the above list and there is still a problem; Contact Service, see Key Contacts (back cover).



Key Contacts

After Sales Service

Over 1100 trained specialists, directly employed by us, ensure that you can have complete confidence in both the appliances and services we offer.

Repair Service and Information Help Desk

UK: 08709 066 066

Monday to Friday, 8am to 7.30pm

Saturday, 8.30am to 5.30pm

Sunday, 9.30am to 3.30pm

www.hotpointservice.co.uk

Republic of Ireland: 1850 302 200

Note: Our operators will require the following information:

Model number

Serial number

Extended Warranties

UK: 08709 088 088

Monday to Sunday, 8am to 8pm

www.hotpointservice.co.uk

Republic of Ireland: 1850 502 200

Genuine Parts and Accessories

UK: 08709 077 077

Monday to Friday, 8.30am to 5pm

Saturday, 8.30am to 12noon

www.hotpointservice.co.uk

Republic of Ireland: (01) 842 6836

www.hotpoint.co.uk

Indesit Company UK Limited, Morley Way, Peterborough, PE2 9JB

Free Manuals Download Website

<http://myh66.com>

<http://usermanuals.us>

<http://www.somanuals.com>

<http://www.4manuals.cc>

<http://www.manual-lib.com>

<http://www.404manual.com>

<http://www.luxmanual.com>

<http://aubethermostatmanual.com>

Golf course search by state

<http://golfingnear.com>

Email search by domain

<http://emailbydomain.com>

Auto manuals search

<http://auto.somanuals.com>

TV manuals search

<http://tv.somanuals.com>