

Installation and User Handbook

BL31 - Integrated Larder Fridge

Retention of the Instruction Book

This Instruction Book must be kept handy for reference as it contains important details on the safe and proper use of the appliance.

If you sell or pass the appliance to someone else, or move house and leave it behind, make sure this Book is also provided so the new owner can become familiar with the appliance and safety warnings.

Your New Integrated Appliance

Using your new integrated appliance is very simple. Nevertheless, to get the best results it is important that you read right through this handbook **before** using your integrated appliance for the first time.

Electrical Requirements

WARNING: This appliance must be earthed.

Fuses

Your appliance comes fitted with a plug and a 13A fuse. If you need to replace the fuse, only those rated at 13A and ASTA approved to BS1362 should be used. If you lose the fuse cover, a replacement may be obtained from your local authorised Service Centre or Electricity company. Correct replacement is identified by colour coding or the marking on base of plug.

WARNING: Do not use plug unless fuse cover is fitted.

Changing the Plug

Cut off and dispose of the supplied plug if it does not fit your socket.

WARNING: To avoid a shock hazard do not insert the discarded plug into a socket anywhere else.

IMPORTANT: WIRES IN THE MAINS LEAD ARE COLOURED IN ACCORDANCE WITH THE FOLLOWING CODE:

| | | |
|--------------|---|---------|
| Green/Yellow | - | Earth |
| Blue | - | Neutral |
| Brown | - | Live |

If you change the plug, the colour of wires in the mains lead may not correspond with the colour of the markings identifying terminals in the plug. You should therefore wire it as shown.

Green and yellow (Earth) wire to terminal marked 'E', symbol, ⊕ or coloured green and yellow.

Blue (Neutral) wire to terminal marked 'N' or coloured black.

13A ASTA approved fuse to BS1362.

Brown (Live) wire to terminal marked 'L' or coloured red.

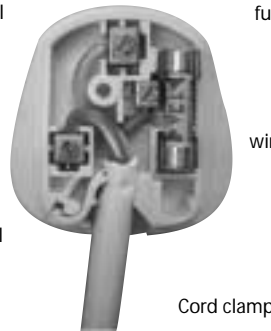

Cord clamp

Changing the Mains Lead

A special lead can be ordered from our Service Department UK: 08709 066 066 or Republic of Ireland: 1850 302 220

If you have damaged the existing lead or require a longer one a charge will be made. It is strongly advised that this work is carried out by a qualified electrician.

CE CE marking certifies that this appliance conforms to the following EEC directives:-
Low Voltage Equipment - 72/23/EEC & 93/68 EEC
Electromagnetic Compatibility - 89/336/EEC, 92/31/EEC & 93/68/EEC

WARNING: AVOID ACCIDENTS TO CHILDREN. WHEN DISCARDING AN OLD FRIDGE OR FREEZER BE CERTAIN TO MAKE THE LOCK UNUSABLE. IF POSSIBLE, REMOVE THE DOOR AND DISCARD SEPERATELY. DO NOT ATTEMPT TO SIT ON TOP OF YOUR APPLIANCE. IT IS NOT DESIGNED FOR SUCH USE AND YOU COULD INJURE YOURSELF OR DAMAGE THE APPLIANCE BY SUCH ABUSE.

Contents

| | Page |
|--|------------|
| Electrical Requirements | 2 |
| Disposal Notes/Technical Safety | 3 |
| Installation | 4-7 |
| Model BL31 Get to know your Integrated Larder Fridge | 8 |
| Getting your Integrated Larder Fridge ready for use | 9 |
| Controlling the Temperature | 9 |
| Storing Food | 10 |
| Do's & Don'ts | 11 |
| Caring for your Integrated Larder Fridge | 12-13 |
| If your Integrated Larder Fridge Won't Work | 14 |
| After Sales | 15 |
| Guarantee | 16 |
| Key Contacts | Back Cover |

Disposal Notes:

The packaging is designed to protect the appliance and individual components during transport and is made of recyclable materials.

Corrugated board/board

Moulded polystyrene (foamed, CFC-free polystyrene).

Polythene bags and sheets

Polypropylene straps

Keep packaging materials away from children - polythene sheets and bags can suffocate!

Please return packaging material to your nearest official collection point so that the various materials can be reused or recycled as far as possible.

Ensure that the refrigerant circuit is not damaged, before the appliance that is no longer needed is taken away for disposal. In this way the refrigerant will not escape into the environment.

Exact details of the refrigerant used can be found on the type plate. The heat insulator is PU with Pentane.

Information on collection dates or collection points can be obtained from the waste disposal authorities or local council.

Technical Safety

The refrigerant R600a is environmentally friendly but flammable, take care not to damage the refrigerant circuit pipes. If refrigerant does escape, immediately ensure that the area is well ventilated.

Do not use electrical appliances; i.e. ice makers, inside the appliance.

In the event that the appliance is damaged, contact the supplier immediately before connecting to the mains.

To guarantee safe operation, ensure that the appliance is set up and connected as described in these operating instructions, and that any repairs and work on the appliance are only carried out by an authorised service office.

Installing Your Integrated Appliance

Please read through this section before starting any work.

The installation location should be in a dry, well ventilated room. The appliance should not be exposed to direct sunlight and should not be near a heat source (e.g. a radiator, cooker). If required, use an insulating plate.

Warning!

The appliance contains the environmentally friendly but flammable refrigerant R600a. Ensure that the refrigerant circuit is NOT damaged during transportation and installation.

Leaking refrigerant may ignite or cause eye injuries.

The more refrigerant in an appliance, the larger the room must be in which the appliance is situated. If a leak occurs in a room which is too small, a flammable gas-air mixture may form.

The room must be at least 1 m³ per 8g of refrigerant. The amount of refrigerant in your appliance is indicated on the rating plate located inside the appliance, on the bottom left hand side.

If refrigerant is leaking out:

- Avoid naked flames and ignition sources near the installation location.
- Unplug the appliance and thoroughly ventilate the room for several minutes.

Installation of the appliance under the worktop

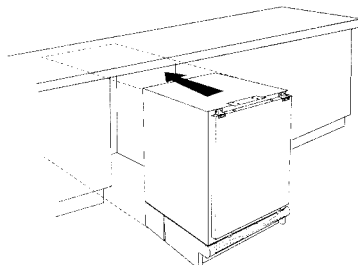

Although you will need to provide all tools required for the installation, all fittings are supplied with the appliance.

Installing Your Integrated Appliance

Before fitting

The electrical socket should be easily accessible.

Do not connect the appliance to the electricity supply until installation is completed.

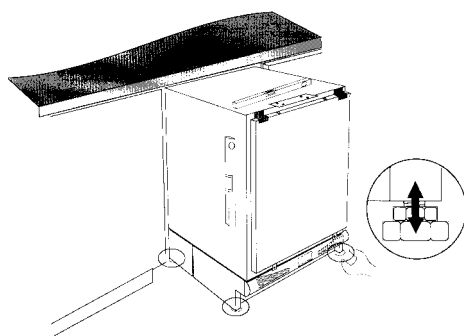
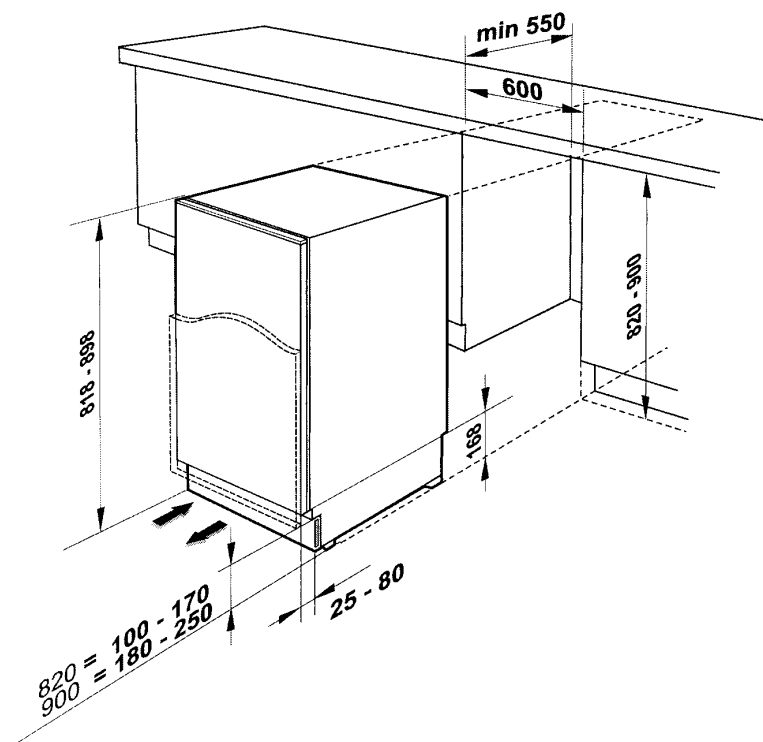

Make sure that the appliance is sitting level on the floor by adjusting all four feet.

Changing over the door hinges

Before fitting, if needed, change over the way the door opens as show below.

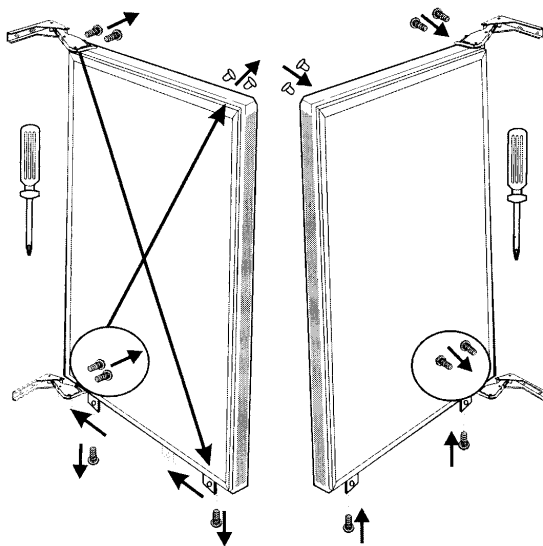
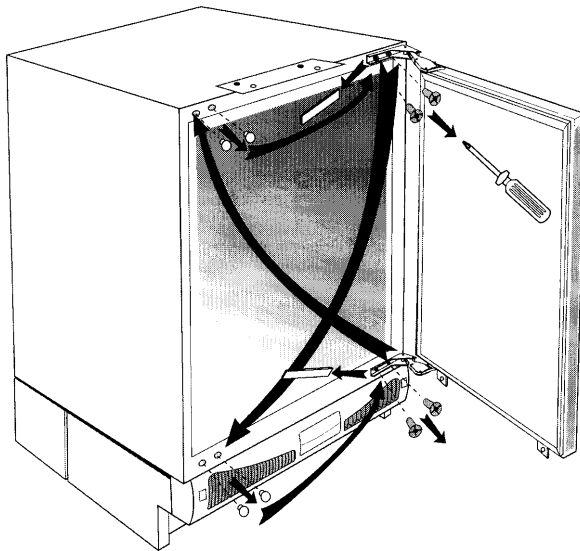

Fastening the appliance under the worktop.
Secure the appliance bracket under the worktop by two fixing screws.

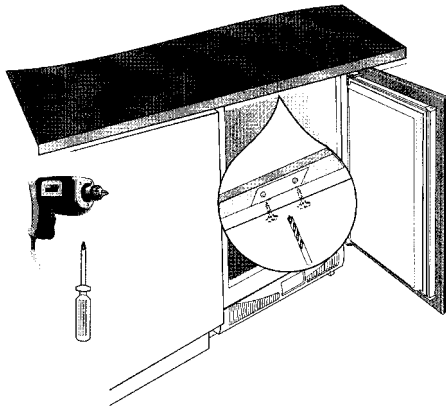

Mounting the kitchen cabinet door.
Remove the top bracket from the appliance and secure to the door panel.

Minimum door width - 595mm
Minimum door height - 650mm

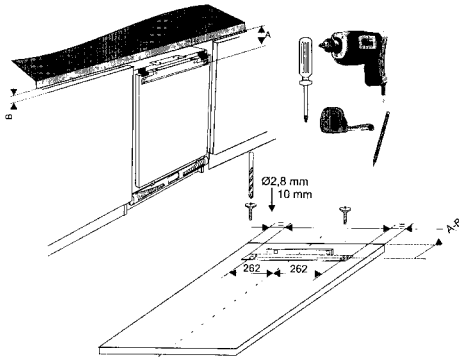

Fitting the door panel to the appliance.

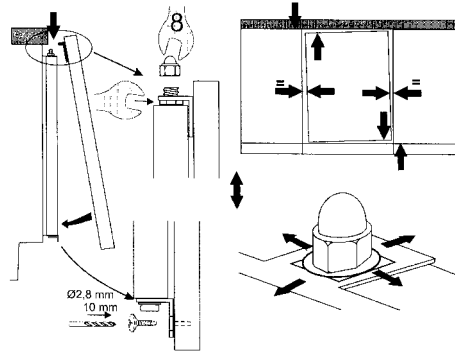

Adjusting the base.
Cut out the plinth of the cabinet to match the appliance bottom ventilation grille.

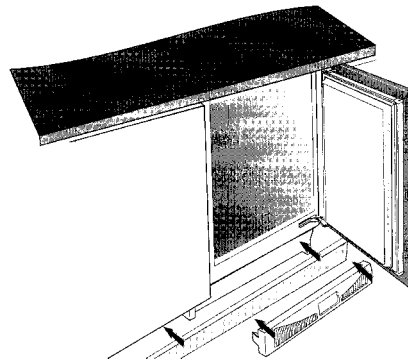

Get to know your Integrated Larder Fridge

Model BL31

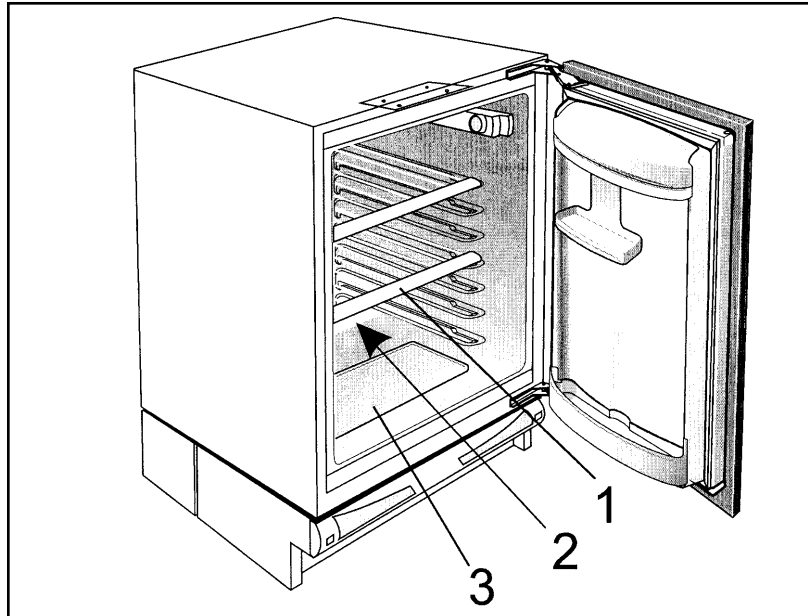

- BL31** FEATURES:
- 1 Shelf
 - 2 Defrost water outlet
 - 3 Crisp tray and serving tray

WARNING: CHILDREN SHOULD NOT BE ALLOWED TO PLAY WITH THE APPLIANCE OR TAMPER WITH THE CONTROLS.

1. Shelf

The shelves are adjustable and can be pulled out and used on any of the guide slots. They can also be used in a tilted position to allow the safe storage of bottles, jars etc. on there sides. To tilt a shelf, place the back of the shelf on a lower slot than the front.

2. The defrost water outlet

The interior of the refrigerator is cooled with a cooling plate incorporated in the rear wall. Under the plate there is a channel and an outlet for the defrosted water. Regularly check the outlet and channel for food deposits which could clog the drain hole. If the hole is blocked, use a plastic straw to clean it out.

3. Crisp tray and serving tray

The tray at the bottom of the refrigerator is covered with the serving tray. This cover protects stored food from excessive drying.

The door liner

The door liner consists of various shelves or holders used for storing eggs, cheese, butter and yogurt as well as other small packages, tubes, cans etc. The lower shelf is used for storing bottles.

The interior light

The light will come on when the door is opened.

Getting your Integrated Larder Fridge Ready for Use

Before using your Integrated Larder Fridge for the first time the interior, including the door and all removable parts should be wiped out. Use a damp cloth wrung out in either a solution of one teaspoon of bicarbonate of soda to one pint of water, or Milton sterilising fluid diluted according to the manufacturer's instructions.

WARNING: NEVER USE ANY HOUSEHOLD CLEANER OR DETERGENT, ABRASIVE POWDERS OR WAX POLISH. THESE NOT ONLY DAMAGE THE SURFACES, THEY ALSO LEAVE A SMELL IN THE LARDER FRIDGE.

Final Check

Before you start using the Larder Fridge, check that:

1. It is thoroughly dry inside
2. Air can circulate freely
3. The feet have been adjusted, ie the feet are firmly on the ground and ensure the appliance is level.

Starting

Insert the plug into the wall socket and switch on the electricity supply. Open your Larder Fridge door and the light will come on. There is a control dial on the right hand side of Larder Fridge interior. Turning the temperature selector dial from '0' (off) towards '7' to the medium setting '4'. You will hear a noise as the compressor starts up.

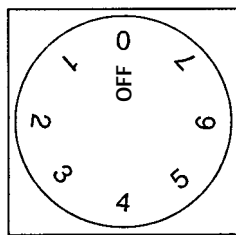

Running in the Compressor

Your Larder Fridge is operated by a compressor which switches on and off in order to maintain the Larder Fridge's temperature. The compressor is a precision piece of machinery like a car engine and requires a a running in period of up to two months. During this time the compressor has to work a little harder and this may result in more noise than usual.

Temperature selection

- * Higher settings on the knob (towards 7) mean lower temperatures. temperature in the interior of the appliance may even drop below 0°C. When the ambient temperature is normal, we recommend the medium setting (4).
- * The temperature in the refrigerator is affected by how often the door is opened and the amount of fresh food recently stored.
- * In the (off) position, the appliance does not operate (the cooling system is switched off). The power supply to the interior light will not be affected and the light will operate when the door is opened.

Tips for energy saving

- * Try not to open the door to often.
- * Check that air is circulating properly through the plinth grille. (e.g. the grille is not blocked or covered).

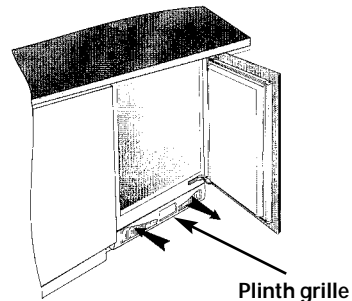

Storing Food

You can store most fresh foods in your Integrated Larder Fridge. Recommended maximum storage times are given in the table below.

| | | Days |
|---|---|--------------|
| Raw fresh meat | joints,steaks, chops | 3-5 |
| | offal (liver, kidney etc) minced meat, sausages | 2 |
| Cooked meat | including made up dishes and left overs | 2-3 |
| Poultry | fresh whole (store giblets separately) | 2-3 |
| | cooked | 2-3 |
| | giblets | 2 |
| Fish | raw | 1-2 |
| | cooked | 2-3 |
| Bacon | | 7-10 |
| Milk, Cream, Salad; vegetables | | 3-4 |
| | | Weeks |
| Butter, Margarine and cooking fats | | 3-4 |
| Cheese | hard | 3-4 |
| | cream | 1 |
| Eggs | | 2 |

All foods should be wrapped or covered to prevent drying out and flavour transference. Plastic bags, containers with lids, foil and plastic stretch wrap are ideal. Never put hot or warm food into your Larder Fridge as this reduces efficiency.

Do's and Don'ts

DO

- Do:-** Take off any unsuitable leaves on vegetables and wipe off any soil.
- Do:-** Leave lettuce, cabbage, parsley and cauliflower on the stem.
- Do:-** Wrap cheese firstly in greaseproof paper and then in a polythene bag excluding as much air as possible. For best results take out of the fridge an hour before eating.
- Do:-** Wrap raw meat and poultry loosely in polythene or aluminium foil. This prevents drying.
- Do:-** Wrap fish and offal in polythene bags.
- Do:-** Wrap foods which have a strong odour or can dry out in polythene bags, aluminium foil or place in airtight containers.
- Do:-** Wrap bread well to keep it fresh.
- Do:-** Chill white wines, beer, lager and mineral water before serving.
- Do:-** Make sure that the gutter at the back of the interior of the Larder fridge is always clear. Check regularly and remove any particles of food which may collect there.
- Do:-** Keep raw meat and poultry below cooked food and dairy products.
- Do:** Clean out the salad bins regularly and check that nothing has dripped into them.
- Do:-** Keep food for as shorter time as possible and adhere to 'sell by' dates.

DON'T

- Don't:-** Store bananas in your Larder fridge.
- Don't:-** Store melon in your Larder Fridge. It can be chilled for short periods as long as it is wrapped to avoid it flavouring other products.
- Don't:-** Wash eggs as this removes their natural protective film. Wipe them instead.
- Don't:-** Use eggs straight from the Larder Fridge, especially when making cakes or mayonnaise. Allow them to reach room temperature before use.
- Don't:-** Leave the door open for long periods as this will make the Larder Fridge more costly to run.
- Don't:-** Cover the shelves with any protective materials which may obstruct air circulation through them.
- Don't:-** Let anything touch the cooling plate at the back of the Larder Fridge.
- Don't:-** Try to keep frozen food which has thawed; it should be eaten within 24 hours.
- Don't:-** Store poisonous or any dangerous substances in the Larder Fridge. Your Larder Fridge has been designed for the storage of edible foodstuffs only.
- Don't:-** Consume food which has been stored for an excessive time in the Larder Fridge.
- Don't:-** Put hot or warm food straight into the Larder Fridge.
- Don't:-** Let food juices drip onto other foods in the Larder Fridge.

Caring for your Integrated Larder Fridge

Cleaning your Integrated Larder Fridge

It is a good idea to clean the inside of your Larder Fridge regularly. **Always switch off at the socket outlet and pull out the mains plug first.**

Remove any food. Wipe out the inside of the Larder Fridge using a clean cloth wrung out in either a solution of one teaspoon of bicarbonate of soda to one pint of water, or Milton diluted according to the manufacturer's instructions.

The complete interior including the door, and removable parts, should be washed with care ensuring that the cloth does not become caught on any part of the appliance. **Never** use any household cleaner or detergent, abrasive powders or wax polish. These not only damage the surfaces, but also leave a smell in the Larder Fridge. Make sure that no particles of food are left in the interior gutter. If the drain hole becomes blocked it may be cleared by pushing the end of a pipe cleaner or drinking straw through the drain hole and gently moving it up and down. **The rubber door seal must be cleaned with soap and water only as a detergent will damage it.**

Automatic defrosting

The refrigerator requires no defrosting, since the ice at the rear wall melts automatically when the compressor is off and water slides downwards through the hole in the rear wall. This is collected in a receptacle placed at the bottom of the appliance.

Going Away

If you expect to be away for any length of time and don't want to use your Larder Fridge, switch off at the power point and pull out the plug. Remove all food and wipe out the interior. **Always** leave the door ajar to prevent the accumulation of odours.

How to Replace the Interior Light

Should the light fail to work, switch off at the power point and pull out the plug. Remove the shelves to make access easier. Access to the bulb is from the rear of the cover (**arrow 1**) and remove the cover in the direction of (**arrow 2**).

Unscrew the old bulb. Screw the new bulb securely into the holder. Replace the plug in the power point and switch on. If the light fails to work, do not worry, it will not affect the working of your Larder Fridge. Obtain a replacement (max 15 watt 220-240V alternating current, E14 lampholder) from your nearest Spares Centre and replace the old bulb.

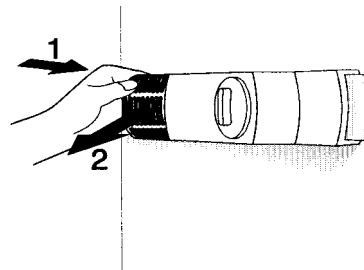

Caring for your Integrated Larder Fridge

Cleaning the condenser

Make sure the appliance is disconnected from the power supply.

Dust from the condenser should be vacuumed as follows;

- * Through the plinth grille, release the fastener.
- * Pull the grille towards you and remove it.
- * Remove the bottom board of the kitchen cabinet.
- * Pull the condenser dish out.
- * Use the vacuum cleaner to clean the dust from the condenser.
- * Replace the condenser dish and the grille in the opposite order.

- * Clean the dust and dirt from the condenser.

After cleaning, refit the appliance back in position, turn the power supply back on and reload.

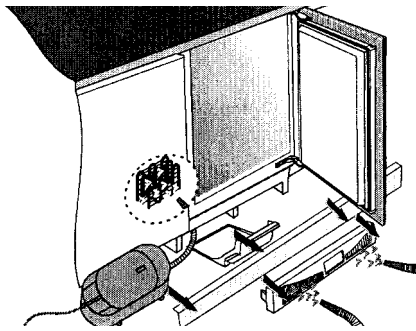

After cleaning, connect the appliance to the power supply and reload it.

Periodical cleaning of the condenser.

Make sure the appliance is disconnected from the power supply.

In order to optimize the operation of the appliance and save energy, it is recommended to periodically clean the dust from the condenser at the back of the appliance.

- * Empty the contents of the appliance.
- * Remove the supporting panel from the bottom of the kitchen cabinet.
- * Remove the screws fixing the appliance to the kitchen worktop.
- * Pull the appliance out and expose the condenser at the back of the appliance.
- * Unscrew the screws from the condenser cover and remove the cover.

If your Integrated Larder Fridge Won't Work

.....Don't Panic!!!

Just run through these quick checks before calling your nearest Service Office.

1. Check that the plug is firmly in the wall socket and that the power supply is on.
2. Check the power supply to the socket by plugging in another appliance.
3. If the other appliance works, check the fuse in the Larder Fridge's plug.
4. If you have changed the plug, check the wiring (see page 2).
5. Make sure the appliance is switched on (the thermostat knob is **not** in the **OFF** position)
6. If there is excessive noise or vibration, ensure the Larder Fridge is raised fully to touch the underside of the worktop. Normal noises may be heard such as; gurgling and the flow of liquid, this may be louder when the appliance is first switched on.
7. If the interior light fails to work, refer to page 12 for further instructions.
8. If water appears on the inside floor or under the salad bins, check that the gutter drain hole has not become blocked, the drain hole may be cleared by pushing the end of a pipe cleaner or drinking straw through the drain hole and gently moving it up and down. (NB Water droplets on the cooling plate or back wall are normal).

If, after following all these instructions, you are still having problems, contact your nearest Service Office (see back page).

After Sales Service

Service Cover...

We appreciate you choosing this quality appliance and we are sure that it will give you many years of excellent service.

Not only have you bought a first class appliance, you've also bought a commitment from us to look after your appliance.

We believe our Care Service is the best in the business and yet another good reason you'll be glad you chose this appliance.

Every appliance has been designed and manufactured to the highest standards. However, in the event of any problem developing, our trained professional engineers are just a phone call away with one real objective - to satisfy you by providing an efficient, effective and courteous service, at a time convenient to you.

Your Guarantee...

The guarantee is subject to the provision(s) that the appliance:

- a) Has been used solely in accordance with the instruction book.
- b) Has been properly connected to a suitable electricity supply voltage as stated on the rating plate attached to the equipment.
- c) Has not been subjected to misuse or accident or been modified or repaired by any person other than an authorised employee or agent.
- d) Has been correctly installed.
- e) Has been used solely for domestic purposes and is on domestic premises.

Your guarantee is only applicable in the U.K. and the Republic of Ireland.

If you suspect a fault with your appliance, to avoid unnecessary inconvenience and expense please ensure that the checks detailed in the '...Won't Work' sections, pages 13, 20 or 25 have been carried out before contacting the SERVICE NETWORK.

Should you require service our receptionist will require the following information:

- Your post code, name and address, type of appliance, model number. (found on the appliance rating plate or in the handbook).
Guarantee/Contract/Insurance Policy Details.
Date of Purchase, and where you purchased it from.

Easy Payment Methods...

You can pay for any of our services offered either by Credit Card (Visa, MasterCard), Cheque and Debit Card. Or in installments by Direct Debit provided you include a Care Plus scheme.

SERVICE U.K.

08709 066 066

Monday - Friday 8am - 8pm,
Saturday 8am - 6pm,
Sunday 10am - 6pm.

Republic of Ireland

1850 302 220

Monday - Friday 8am - 5.30pm,
Saturday 9.00am - 12.30pm.

Guarantee

High quality after-sales service levels...

- **IN GUARANTEE (Year 1)**
All appliances carry a FREE fully inclusive 12 months parts and labour guarantee.
If service under your Year 1 Guarantee is required please have available evidence of your date of purchase when the engineer calls.
- **OUT OF GUARANTEE (Years 2-10)**
Once an appliance is over 12 months old, and goes out of guarantee, we offer you a very simple choice of service levels:

CARE LEVEL 1: No advance fee payable, no registration necessary.
Should a repair be needed in years 2-10, (i.e. over 12 months old) your Regional Service Centre will advise you of the fixed labour charge we will make. Although this charge will vary according to your location and the type of appliance you own, **it is fixed regardless of the time taken or the number of visits needed to complete the repair.**
The cost of parts where required will be charged additional to the fixed labour charge, but again this cost will have a maximum level of which you will be advised by your Regional Service Centre. The repair itself is fully guaranteed for 12 months.

CARE LEVEL 2: Annual fee payable all inclusive cover provided.
You may prefer the peace of mind of an all-inclusive type of cover: this is provided by our Care Plus Scheme which, for an annual fee covers the cost of any parts or labour. This applies on appliances up to 10 years old.
For your convenience this fee can be paid in installments by Direct Debit. Payments can also be made by Credit Card (Visa, MasterCard), Cheque and Debit Card.

CARE LEVEL 3: Kitchen Cover
For an extra fee, you can also purchase Kitchen Cover for all of our brand appliances you own, provided they are under 10 years old. To join simply call **0800 716 356** and register.

EASY ACCESS REPAIR SERVICE
One number - **08709 066 066** connects you automatically to your U.K. Regional Service Centre to arrange for your local engineers to call.
Office opens 7 days a week, 364 days a year,
Monday - Friday 8am - 8pm, Saturday 8am - 6pm, Sunday 10am - 6pm.
For the Republic of Ireland call **1850 302 220**,
Monday - Friday 8am - 5.30pm, Saturday 9.00am - 12.30pm.
This is the largest appliance manufacturer service team in Europe. Trained specialists covering all our appliances (and directly employed by us).
If contacted before 10am, we try to offer a service call the same day where required or the next working day. (Monday to Friday). On request, your service call can be the first or last of the day with am or pm timings always available. We can also cater to meet your specific needs ie. avoiding school hours whenever we can.
A chargeable service is offered on the basis of payment on completion to our service engineer, who will issue a receipt.

Our Service Engineers drive recognisable vans, wear uniforms and carry identity cards.
Our Service Engineers will only fit genuine parts.

ANSWER CENTRE

Information and advice regarding specific appliance features and pricing on any of our appliances, before or after purchase.

From anywhere in the U.K., telephone **08701 50 60 70** from 8.45am - 5.30pm, Monday - Friday.

PARTS NATIONAL MAIL ORDER HOTLINE

The Parts Mail Order Hotline enables you to order parts directly from the manufacturer over the phone. A wide range of parts and accessories are available for your appliance.

Telephone: 08709 077 077 Fax: 0541 532 532

Republic of Ireland Parts Telephone: 01 842 6836

Monday - Friday 8.30am - 5.30pm, Saturday 8.30am - 12 noon.

Ring quoting your appliance model number and we will help you get the right parts. National Warehouse comprehensively stocked over 33,000 parts lines. Parts stocked for all models. Parts carried for all appliances up to 10 years old, (15 on Heating appliances). Optional 24 hour express courier service. (Additional charge).

CARE FOR THE DISABLED

We offer a range of accessories which enable our blind arthritic or disabled customers to use most of our appliances. Simply call **08709 077 077** and provide the model number details.

Key Contacts

Service

UK: 08709 066 066

Republic of Ireland: 1850 302 220

You will be asked for the following information:-

Name, address and postcode.

Telephone number

Model / Serial number of the appliance

Clear and concise details of the query or fault

Place and Date of purchase

(Please keep the receipt as evidence will be required when the engineer calls).

Extended Warranty

To join: UK 08709 088 088

Republic of Ireland: 1850 302 220

Genuine Parts & Accessories Mail Order Hotline

UK: 08709 077 077

Republic of Ireland: (01) 842 6836

For further product information 08701 50 60 70

All Services are offered as an extra benefit and do not affect your statutory rights.

General Domestic Appliances Limited, Morley Way, Peterborough, PE2 9JB

Part No. FP069 - 01

Free Manuals Download Website

<http://myh66.com>

<http://usermanuals.us>

<http://www.somanuals.com>

<http://www.4manuals.cc>

<http://www.manual-lib.com>

<http://www.404manual.com>

<http://www.luxmanual.com>

<http://aubethermostatmanual.com>

Golf course search by state

<http://golfingnear.com>

Email search by domain

<http://emailbydomain.com>

Auto manuals search

<http://auto.somanuals.com>

TV manuals search

<http://tv.somanuals.com>